

OPERATING, MAINTENANCE & PARTS MANUAL

VARIABLE SPEED ELECTRIC CHAIN HOIST

CM[®] LODESTAR[®] VS

Before installing hoist, fill in the information below.

Model Number _____
Serial No. _____
Purchase Date _____
Voltage _____
Rated Load _____

RATED LOADS 1/8 TO 1 TONNES 125 KG TO 1000 KG

Follow all instructions and warning for inspecting,
maintaining and operating this hoist.

The use of any hoist presents some risk of personal injury
or property damage. That risk is greatly increased if proper
instructions and warnings are not followed. Before using
this hoist, each operator should become thoroughly familiar
with all warnings, instructions and recommendations in this
manual. **Retain this manual for future reference and use.**

Forward this manual to operator. Failure to operate equipment
as directed in manual may cause injury.



CM HOIST PARTS AND SERVICES ARE AVAILABLE IN THE UNITED STATES AND IN CANADA

PARTS FOR YOUR HOIST ARE AVAILABLE FROM YOUR LOCAL AUTHORIZED REPAIR STATION. FOR THE NAME OF THE NEAREST PARTS OR SERVICE CENTER, VISIT OUR WEB SITE WWW.CMWORKS.COM OR CALL OUR CUSTOMER SERVICE DEPARTMENT.

LAS PIEZAS Y REPARACIONES DE LOS POLIPASTOS DE CM ESTÁN ASEGURADAS EN ESTADOS UNIDOS Y CANADÁ

COMO USUARIO DE UN POLIPASTO Y CARRO DE CM LE ASEGURAMOS CUALQUIER REPARACIÓN O LA DISPONIBILIDAD DE CUALQUIER PIEZA DE REPUESTO A TRAVÉS DE UNA RED DE ALMACENES DE PIEZAS DE REPUESTO Y CENTROS DE SERVICIO SITUADOS ESTRATÉGICAMENTE EN ESTADOS UNIDOS Y CANADÁ. ESTAS INSTALACIONES SE HAN SELECCIONADO EN BASE A SU CAPACIDAD DEMOSTRADA EN LA REPARACIÓN DE EQUIPOS Y SUMINISTRO DE PIEZAS DE REPUESTO DE FORMA RÁPIDA Y EFICAZ. PARA OBTENER LA DIRECCIÓN DEL ALMACÉN DE PIEZAS DE REPUESTO O DEL CENTRO DE SERVICIO MÁS CERCANO, LLAME AL TELÉFONO (800) 888-0985. FAX: (716) 689-5644 (SÓLO EN ESTADOS UNIDOS Y CANADÁ).

LE SERVICE DE RÉPARATION ET DE PIÈCES POUR PALANS CM EST DISPONIBLE AUX ÉTATS-UNIS ET AU CANADA

SOYEZ ASSURÉS QU'EN TEMPS D'UTILISATEUR DE PALAN ET TREUIL CM, D'UN SERVICE DE RÉPARATION ET DE PIÈCES FIABLE PAR L'ENTREMISE D'UN RÉSEAU DE CENTRES DE SERVICE ET DE DÉPÔTS DE PIÈCES MAÎTRESSES QUI SONT STRATÉGIQUEMENT SITUÉS AUX ÉTATS-UNIS ET AU CANADA. CES ÉTABLISSEMENTS ONT ÉTÉ SÉLECTIONNÉS SUR UNE BASE DE LEUR HABILITÉ DÉMONTRÉE À S'OCCUPER PROMPTEMENT ET EFFICACEMENT DES BESOINS DE RÉPARATION DE PIÈCES. APPELEZ LE (800) 888-0985, FAX: (716) 689-5644 POUR OBTENIR RAPIDEMENT LE NOM DU DÉPÔT DE PIÈCES MAÎTRESSES OU DU CENTRE DE SERVICE SITUÉ LE PLUS PRÈS.

WARNING

Usage of hoists that do not involve lifting of the load on the lower hook or using hoists in the inverted position without special precaution may cause an accident resulting in injury and/or property damage

TO AVOID INJURY:

Consult Columbus McKinnon for information concerning using hoists in these applications.

WARNING

Improper operation of a hoist can create a potentially hazardous situation which, if **NOT** avoided, could result in death, or serious injury. To avoid such a potentially hazardous situation, the operator shall:

1. **NOT** operate a damaged, malfunctioning or unusually performing hoist.
2. **NOT** operate the hoist until you have thoroughly read and understood this Operating, Maintenance and Parts Manual.
3. **NOT** operate a hoist which has been modified.
4. **NOT** lift more than rated load for the hoist.
5. **NOT** use hoist with twisted, kinked, damaged, or worn load chain.
6. **NOT** use the hoist to lift, support, or transport people.
7. **NOT** lift loads over people.
8. **NOT** operate a hoist unless all persons are and remain clear of the supported load.
9. **NOT** operate unless load is centered under hoist.
10. **NOT** attempt to lengthen the load chain or repair damaged load chain.
11. Protect the hoist's load chain from weld splatter or other damaging contaminants.
12. **NOT** operate hoist when it is restricted from forming a straight line from hook to hook in the direction of loading.
13. **NOT** use load chain as a sling, or wrap load chain around load.
14. **NOT** apply the load to the tip of the hook or to the hook latch.
15. **NOT** apply the load unless load chain is properly seated in the chain wheel(s) or sprocket(s).
16. **NOT** apply load if bearing prevents equal loading on all load supporting chains.
17. **NOT** operate beyond the limits of the load chain travel.
18. **NOT** leave load supported by the hoist unattended unless specific precautions have been taken.
19. **NOT** allow the load chain or hook to be used as an electrical or welding ground.
20. **NOT** allow the load chain or hook to be touched by a live welding electrode.
21. **NOT** remove or obscure the warnings on the hoist.
22. **NOT** operate a hoist on which the safety placards or decals are missing or illegible.
23. **NOT** operate a hoist unless it has been securely attached to a suitable support.
24. **NOT** operate a hoist unless load slings or other approved single attachments are properly sized and seated in the hook saddle.
25. Take up slack carefully - make sure load is balanced and load holding action is secure before continuing.
26. Shut down a hoist that malfunctions or performs unusually and report such malfunction.
27. Make sure hoist limit switches function properly.
28. Warn personnel of an approaching load.

CAUTION

Improper operation of a hoist can create a potentially hazardous situation which, if not avoided, could result in minor or moderate injury. To avoid such a potentially hazardous situation, the operator shall:

1. Maintain a firm footing or be otherwise secured when operating the hoist.
2. Check brake function by tensioning the hoist prior to each lift operation.
3. Use hook latches. Latches are to retain slings, chains, etc. under slack conditions only.
4. Make sure the hook latches are closed and not supporting any parts of the load.
5. Make sure the load is free to move and will clear all obstructions.
6. Avoid swinging the load or hook.
7. Make sure hook travel is in the same direction as shown on the controls.
8. Inspect the hoist regularly, replace damaged or worn parts, and keep appropriate records of maintenance.
9. Use the hoist manufacturer's recommended parts when repairing the unit.
10. Lubricate load chain per hoist manufacturer's recommendations.
11. **NOT** use the hoist load limiting or warning device to measure load.
12. **NOT** use limit switches as routine operating stops unless allowed by manufacturer. They are emergency devices only.
13. **NOT** allow your attention to be diverted from operating the hoist.
14. **NOT** allow the hoist to be subjected to sharp contact with other hoists, structures, or objects through misuse.
15. **NOT** adjust or repair the hoist unless qualified to perform such adjustments or repairs.

SAFETY PRECAUTIONS

Each Lodestar Electric Hoist is built in accordance with the specifications contained herein and at the time of manufacture complied with our interpretation of applicable sections of the "American Society of Mechanical Engineers Code B30.16 "Overhead Hoists," the National Electrical Code (ANSI/NFPA 70) and the Occupational Safety and Health Act. Since OSHA states the National Electrical Code applies to all electric hoists, installers are required to provide current overload protection and grounding [on the branch circuit section] in keeping with the code. Check each installation for compliance with the application, operation and maintenance sections of these articles.

The safety laws for elevators, lifting of people and for dumbwaiters specify construction details that are not incorporated into the hoists. For such applications, refer to the requirements of applicable state and local codes, and the American National Safety Code for elevators, dumbwaiters, escalators and moving walks (ASME A17.1). Columbus McKinnon Corporation cannot be responsible for applications other than those for which CM equipment is intended.

*Copies of this standard can be obtained from ASME Order Department, 22 Law Drive, Box 2300, Fairfield, NJ 07007-2300, U.S.A.



THIS SYMBOL POINTS OUT IMPORTANT SAFETY INSTRUCTIONS WHICH IF NOT FOLLOWED COULD ENDANGER THE PERSONAL SAFETY AND/OR PROPERTY OF YOURSELF AND OTHERS. READ AND FOLLOW ALL INSTRUCTIONS IN THIS MANUAL AND ANY PROVIDED WITH THE EQUIPMENT BEFORE ATTEMPTING TO OPERATE YOUR LODESTAR HOIST.

HOIST SAFETY IS UP TO YOU...

WARNING

DO NOT LIFT MORE THAN RATED LOAD.

CHOOSE THE RIGHT HOIST FOR THE JOB...

Choose a hoist with the capacity for the job. Know the capacities of your hoists and the weight of your loads. Then match them.

The application, the size and type of load, the attachments to be used and the period of use must also be taken into consideration in selecting the right hoist for the job.

Remember, the hoist was designed to ease our burden and carelessness not only endangers the operator, but in many cases, a valuable load.



WARNING

DO NOT OPERATE DAMAGED OR MALFUNCTIONING HOIST.

DO NOT OPERATE WITH TWISTED, KINKED, OR DAMAGED CHAIN.

INSPECT

All hoists should be visually inspected before use, in addition to regular, periodic maintenance inspections.

Inspect hoists for operations warning notices and legibility.

Deficiencies should be noted and brought to the attention of supervisors. Be sure defective hoists are tagged and taken out of service until repairs are made.

Under no circumstances should you operate a malfunctioning hoist.

Check for gouged, twisted, distorted links and foreign material. Do not operate hoists with twisted, kinked, or damaged chain links.

Load chain should be properly lubricated.

Hooks that are bent, worn, or whose openings are enlarged beyond normal throat opening should not be used. If latch does not engage throat opening of hook, hoist should be taken out of service.

Chains should be checked for deposits of foreign material which may be carried into the hoist mechanism.

Check brake for evidence of slippage under load.



WARNING

DO NOT PULL AT AN ANGLE. BE SURE HOIST AND LOAD ARE IN A STRAIGHT LINE.

DO NOT USE LOAD CHAIN AS A SLING.

USE HOIST PROPERLY

Be sure hoist is solidly held in the uppermost part of the support hook arc.

Be sure hoist and load are in a straight line. Do not pull at an angle.

Be sure load is hooked securely. Do not tip load the hook. Do not load hook latch. Hook latch is to prevent detachment of load under slack chain conditions only.

Do not use load chain as a sling. Such usage damages the chain and lower hook.

Do not operate with hoist head resting against any object. Lift the load gently. Do not jerk it.

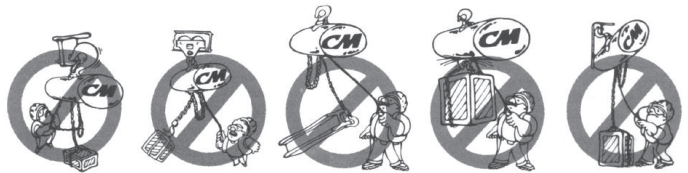

WARNING

DO NOT LIFT PEOPLE OR LOADS OVER PEOPLE

LIFT PROPERLY

Do not lift co-workers with a hoist.

Make sure everyone is clear of the load when you lift.

Do not remove or obscure operational warning notices.



MAINTAIN PROPERLY

CLEANING

Hoists should be kept clean and free of dust, dirt, moisture, etc., which will in any way affect the operation or safety of the equipment.

LUBRICATION

Chain should be properly lubricated.

AFTER REPAIRS

Carefully operate the hoist before returning it to full service.



VIOLATIONS OF ANY OF THE WARNINGS LISTED MAY RESULT IN SERIOUS PERSONAL INJURY TO THE OPERATOR OR NEARBY PERSONNEL BY NATURE OF RELEASED LOAD OR BROKEN HOIST COMPONENTS.

FOREWORD

This manual contains important information to help you properly install, operate and maintain your hoist for maximum performance, economy and safety.

Please study its contents thoroughly before putting your hoist into operation. By practicing correct operating procedures and by carrying out the recommended preventive maintenance suggestions, you will experience long, dependable and safe service. After you have completely familiarized yourself with the contents of this manual, we recommend that you carefully file it for future reference.

The information herein is directed to the proper use, care and maintenance of the hoist and does not comprise a handbook on the broad subject of rigging.

Rigging can be defined as the process of lifting and moving heavy loads using hoists and other mechanical equipment. Skill acquired through specialized experience and study is essential to safe rigging operations. For rigging information, we recommend consulting a standard textbook on the subject.

TABLE OF CONTENTS

Safety Precautions	3-4	Assembly Instructions	
Foreword	5	Swivel Hook or Lug Suspensions	38
General Information		Fasteners.....	38
Specifications.....	6	Lower Hook Block Pin.....	38
CM Repair/Replacement policy	6	Removal and Installation of Load Chain	38-39
Accessories		Cutting Chain	40
Hook Suspensions	7	Ordering Instructions.....	40
Chain Container	7	Chain Stop Installation	40
Latchlok Hooks	7	Parts List	41-55
Lug Suspension	8	Main Assembly.....	41-43
Series 635 Low Headroom Trolley	8	Gearbox Assembly.....	44-45
Series 635 Motor Driven Trolley	8	Upper Suspension	46-48
CM Universal (UT) Trolley.....	8	Lower Hook.....	49-50
CM Rocket Universal Pendant Control	8	DC Brake.....	51
Installation		Backframe Cover Assembly.....	52
Unpacking Information.....	9	Control Cord and Station	53-54
Installing Suspension	9	CM Rocket Universal Pendant Control	55
Attaching Load Chain.....	9	Chain Container Installation	56
Power Supply and Electrical Connections.....	10	Lubricants.....	57
Three Phase Hoist.....	11	Recommended Spare Parts	57
Power Phasing	11		
Checking for Twist in Load Chain Models E and H.....	11		
Checking for Adequate Volatage at Hoist.....	11		
Signs of Inadequate Electrical Power	11		
Checking Limit Switch (EPLS) Operation.....	12		
Control Cord.....	12		
Operating Instructions			
General.....	12		
Hoist.....	13		
Hoist with Motor Driven Trolley	13		
Safety Procedures.....	13		
Thermochromic Labels	13		
Inspection			
Inspection.....	14		
Normal Service.....	14		
Heavy Service	14		
Severe Service	14		
Frequent Inspections	14		
Periodic Inspections.....	14		
Preventative Maintenance.....	14		
Suspension Inspection Criteria	14		
Hook Removal Criteria	14		
Inspecting the Load Chain	16		
Maintenance			
Load-limiter	17		
Hoist Lubrication	17		
Trolley Lubrication	17		
Exterior Finish	17		
Temperature Rating.....	17		
Brake Adjustments.....	17		
Limit Switches.....	18		
Slow Approach.....	18		
Programming VFD.....	19-33		
Troubleshooting.....	34-35		
Electrical Data	36		
Reference Wiring Diagrams	37		

LIST OF TABLES

Table	Title	Page
1	Specifications	6
2a	Torque Specification: All Models	10
2b	Torque Specification: Models A-H.....	10
3	Voltage Ranges	10
4	Minimum Running Voltage.....	11
5	Minimum Wire Size	12
6	Hook Inspection Dimensions.....	14
7	Minimum Frequent Inspections	15
8	Minimum Periodic Inspections	15
9	Chain Dimensions.....	16
10	Load Limiter Part Numbers.....	17
11	Limit Switches.....	18
12	Troubleshooting	34-35
13	Electrical Data for Hoist Components	36

LIST OF ILLUSTRATIONS

Figure	Title	Page
1	Chain Container	7
2	Latchlok Hook.....	7
3	Series 635 Low Headroom Trolley	7
4	Series 635 Motor Driven Trolley	7
5	UT Trolley.....	7
6	CM Rocket Universal Pendant Control	7
7	Attaching Load Chain	10
8	Location of Components	11
9	Hook Inspection.....	14
10	Chain Wear Areas	16
11	Gaging Load Chain Wear.....	16
12	Chain Embossing.....	16
13	Hook Suspension.....	38
14	Cutting Chain By Nicking.....	40
15	Cutting Chain With A Bolt Cutter	40
16	Chain Stop Installation.....	40

GENERAL INFORMATION

SPECIFICATIONS

The Lodestar Electric Chain Hoist is a highly versatile materials handling device that can be used to lift loads that are within rated capacity. The mechanical features of these hoists include an alloy steel liftwheel, Load Limiter, hardened steel chain guides, hardened steel gear train, life-time lubrication, forged steel hooks and lightweight aluminum frame. The electrical features include hoist-duty motor, rugged hoist brake, variable frequency drive and electronic brake controller circuit. The hoist is available with hook or lug suspensions that are supplied separately. Table 1 summarizes the Lodestar Electric Chain Hoist models and the Series 635 Trolleys available. It should be noted that standard hoists are available with 10 (3M), 15 (4.6M) and 20 (6.1M) foot lifts. However, hoists with longer lifts are available on a special, per order basis.

CM REPAIR/REPLACEMENT POLICY

All Columbus McKinnon (CM®) Lodestar Electric Chain Hoists are inspected and performance tested prior to shipment. If any properly maintained hoist develops a performance problem due to a material or workmanship defect, as verified by CM®, repair or replacement of the unit will be made to the original purchaser without charge. This repair/replacement policy applies only to Lodestar Hoists installed, maintained and operated as outlined in this manual, and specifically excludes parts subject to normal wear, abuse, improper installation, improper or inadequate maintenance, hostile environmental effects and unauthorized repairs/modifications.

We reserve the right to change materials or design if, in our opinion, such changes will improve our product. Abuse, repair by an unauthorized person, or use of non-CM replacement parts voids the guarantee and could lead to dangerous operation. For full Terms of Sale, see Sales Order Acknowledgement. Also, refer to the back cover for Limitations of Warranties, Remedies and Damages, and Indemnification and Safe Operation.

SPECIFICATIONS

Table 1.

Lodestar Electric Chain Hoists 200-240VAC or 380-480VAC, 3-Phase, 50/60Hz											
Model	Load Capacity		Lifting Speed 60Hz Output		Lifting Speed 50Hz Output		Chain Falls	Chain Size		Chain Weight per length of lift	
	Tonne	kg	ft/min	m/min	ft/min	m/min		in x in	mm x mm	lb/ft	kg/m
A	1/8	125	32	9.8	26.7	8.1	1	.250 x .7445	6.35 x 18.9	0.585	0.87
AA	1/8	125	60	18.3	50.0	15.2	1	.250 x .7445	6.35 x 18.9	0.585	0.87
B	1/4	250	16	4.9	13.3	4.1	1	.250 x .7445	6.35 x 18.9	0.585	0.87
C	1/4	250	32	9.8	26.7	8.1	1	.250 x .7445	6.35 x 18.9	0.585	0.87
E	1/2	500	8	2.4	6.7	2.0	2	.250 x .7445	6.35 x 18.9	1.17	1.74
F	1/2	500	16	4.9	13.3	4.1	1	.250 x .7445	6.35 x 18.9	0.585	0.87
H	1	1000	8	2.4	6.7	2.0	2	.250 x .7445	6.35 x 18.9	1.17	1.74

Lodestar Electric Chain Hoists 200-240VAC or 380-480VAC, 3-Phase, 50/60Hz									
Model	Shortest Distance Between Hooks		Motor Power 60Hz Output		Motor Power 50Hz Output		IP Rating	Net Weight Standard 10', 230V Unit Add .5lb (.3kg) for 460V	
	in	mm	HP	kW	HP	kW		lb	kg
A	16.9	429	0.25	0.19	0.21	0.16	66	66	30
AA	19.9	505	0.50	0.37	0.42	0.31	66	67	30
B	16.9	429	0.25	0.19	0.21	0.16	66	67	30
C	16.9	429	0.50	0.37	0.42	0.31	66	66	30
E	21.6	549	0.25	0.19	0.21	0.16	66	81	37
F	16.9	429	0.50	0.37	0.42	0.31	66	67	30
H	21.6	549	0.50	0.37	0.42	0.31	66	81	37

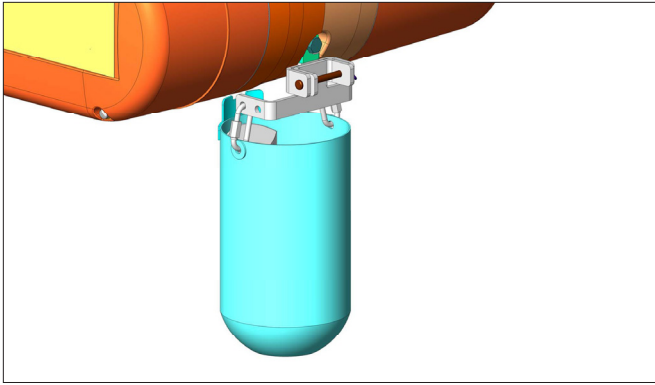

Figure 1. Chain Container



Figure 2. Latchlok Hook

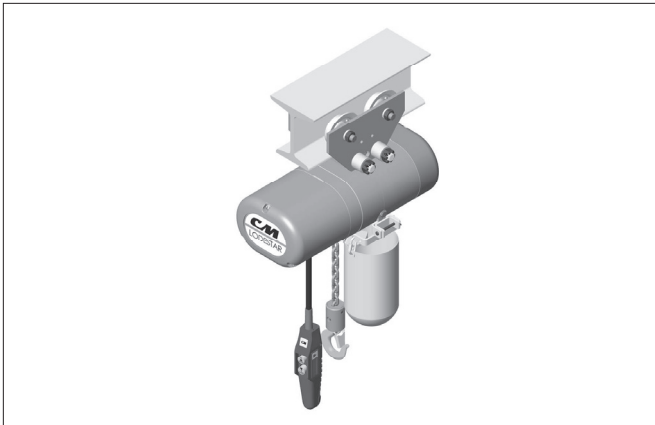

Figure 3. Series 635 Low Headroom Trolley



Figure 4. Series 635 Motor Driven Trolley



Figure 5. UT Trolley



Figure 6. CM® Rocket™ Universal Pendant Control

ACCESSORIES

HOOK SUSPENSIONS

Swivel and rigid type hook suspensions are available for all Lodestar Electric Hoists. However, rigid type hook suspensions are normally recommended for most application. The hook suspensions are intended for suspending the hoist from a trolley which has a single load bar (such as CM® Series 632 and 633 Trolleys) or for suspending the hoist from a fixed structure.

CHAIN CONTAINER

This accessory (see Figure 1) is used to hold slack chain and it is supplied complete with mounting hardware and instructions. The chain container is recommended for those applications where the slack chain would interfere with the load or drag on the floor as may be the case with double or triple reeved units. Chain containers can be furnished for units already in use.

LATCHLOK® HOOKS

CM Latchlok hooks (see Figure 2) are available to replace the standard upper and lower hooks used on the Lodestar Electric Hoists.

LUG SUSPENSION

Lug suspensions are available for all Lodestar Electric Hoists. These are rigid type suspensions wherein the lug shown replaces the hook in the suspension adapter. The Lug suspensions are required for suspending the hoist from the Series 635 Low Headroom, Motor Driven, Universal Trolleys described next.

SERIES 635 LOW HEADROOM TROLLEY

These are manual push type trolleys (see Figure 3) designed for use with the Lodestar Electric Chain Hoists. A rigid lug suspension is required to suspend the hoist from the trolley. The trolley is adjustable for operation on a range of American Standard "S" beams and it will also operate on flat flanged beams.

SERIES 635 MOTOR DRIVEN TROLLEY

The motor driven trolleys (see Figure 4) are self-contained and supplied complete with independent controls and wiring, including a four directional control station. A rigid lug suspension is required to suspend the hoist from the Motor Driven Trolley. The hoist and trolley are joined electrically by connecting the hoist control and power cords (supplied) into the hoist or trolley. The trolley is adjustable for operation on a range of American Standard "S" beams and it will also operate on flat flanged beams.

CM UNIVERSAL (UT) TROLLEY

The CM Universal Trolley (UT) is designed to fit virtually all Columbus McKinnon powered chain hoists up to 3 ton capacities. The rugged UT is available as a convertible plain unit, a geared unit ideal for precise hoist positioning, and a motorized unit that's perfect for applications requiring high cycling and long distance hoist travel.

CM® ROCKET™ UNIVERSAL PENDANT CONTROL

The CM Rocket Pendant Control is engineered for maximum operator comfort, while delivering the precision control your application demands.

INSTALLATION

UNPACKING INFORMATION

When received, the hoist should be carefully inspected for damage which may have occurred during shipment or handling. Check the hoist frame for dents or cracks, the external cords for damaged or cut insulation, the control station for cut or damaged enclosure, and inspect the load chain for nicks and gouges. If shipping damage has occurred, refer to the packing list envelope on the carton for claim procedure.

Before installing the hoist, make sure that the power supply to which it will be connected is the same as that shown on the nameplate located on the side of the hoist.

NOTE: See Electrical Installation instructions

INSTALLING THE SUSPENSION

A. Single Reeved Units:

For Models A, AA, B, C & F:

Remove the hook suspension and (2) suspension screws from the packaging. Place the suspension assembly into the recess on top of the hoist so that the adaptor body follows the contour of the hoist. Insert the suspension screws through the holes in the adapter and hand thread these into the self-locking nuts enclosed in the hoist.

Securely tighten the screws to the recommended seating torque (see Table 2) using a 12 point socket: 3/8" for Models A, AA, B, C & F.

CAUTION

Use of impact tools (electric or pneumatic) may cause premature failure of attaching hardware.

B. Double Reeved Units:

Remove the hook suspension, (2) suspension screws, (1) dead end pin, (1) washer, and (1) cotter pin from the packaging. It should be noted that the suspension includes a dead end bolt and block for supporting the dead end of the load chain as shown in Figure 7.

Place the suspension assembly into the recess on top of the hoist. The dead end block should project through the bottom of the hoist with the pin hole and slot aligned to the underside of the hoist as shown in Figure 7. If these are not aligned as shown, lift the head of the bolt from the hex recess in the adapter and turn the bolt and block assembly and reseal the bolt head to obtain the proper alignment. Do not change the position of the dead end block on the bolt to attain this alignment.

Check the position of the pin hole in the dead end block to make sure it has not been disturbed from its factory setting. The distance from the top of the pin hole to the bottom of the hoist should not exceed 1/4" (6.35mm) for Models E & H. If the distance is not correct, adjust the position of the dead end block to obtain the proper distance (see fig. 13, p 38.)

Now, insert the suspension screws through the holes in the adapter and hand thread these into the self-locking nuts enclosed in the hoist frame. Securely tighten the screws to the recommended seating torque (see Table 2) using a 12 point socket: 3/8" for Models E & H.

WARNING

Using other than CM supplied high strength suspension screws to attach the suspension adapter to the hoist may cause the screws to break and allow the hoist and load to fall.

TO AVOID INJURY:

Use only the CM supplied suspension screws to attach the suspension to the hoist and hand torque these screws to the recommended seating torque as specified in tables 2a and 2b. DO NOT apply any type of lubricant to the threads of these screws. Lubricating the threads will reduce the effort to seat the screws and as a result, tightening the screws to the above recommended torque may break the screw, damage the suspension adapter, strip the nuts and/or damage the hoist frame.

SUSPENSION BOLT SHOULD BE REPLACED ANY TIME THE SUSPENSION IS REMOVED FROM THE HOIST

ATTACHING LOAD CHAIN

Single Reeved

1. Suspend the hoist from an adequate support.
2. If replacing existing chain, remove chain block kit from loose end of chain by removing the two (2) screws from opposing sides of the block. Remove lower hook assembly by removing the pin holding the chain into the assembly.
3. Limit switch settings will need to be disabled when removing or installing chain. Refer to the limit switch section.
4. Using the connecting link, attach new chain to end of starter chain (existing chain if replacing) and feed through chain guides and over liftwheel. Feed enough chain through to be able to attach the chain block kit to the loose end of the chain by assembling the screws and nuts into the appropriate slots and tightening securely.
5. Attach the lower hook assembly to the appropriate end of the chain, by inserting the end link of the chain into the block, and securing the link with the pin.
6. Set upper and lower travel limits, before putting unit into service. Refer to the limit switch section.

Double Reeved

1. Suspend the hoist from an adequate support.
2. Insert the last link of the load chain into the dead end block (1) and secure it with the dead end pin, washer and cotter pin furnished with the suspension. Ensure there are no twists in the chain.

Do not remove the plastic ties from the load chain at this time. After the suspension is installed, hoists with a hook suspension can be suspended from its permanent support and then connected to the power supply system (refer to page 14). For hoists with a lug suspension that are to be suspended from a Series 635 Low Headroom Trolley, attach the hoist to the trolley per the following instructions.

Table 2a. Torque Specification: All Models

Fastener	Fastener Description	Tool Required	*Recommended Seating Torque	
			ft-lbf	N-m
Brake End Cover	1/4"-20 Socket Head Cap Screw	3/16" Hex Driver	4.2 - 5.0	5.7 - 6.8
Motor End Cover	1/4"-20 Socket Head Cap Screw	3/16" Hex Driver	4.2 - 5.0	5.7 - 6.8
1/4"-20 Button Head Screw for Miscellaneous Applications	1/4"-20 Button Head Socket Cap Screw	5/32" Hex Driver	4.2 - 5.0	5.7 - 6.8
Cord Grips	ø3/4" NPT Cord Grip	1-1/16" Hex Socket or Wrench	5.0 - 5.8	6.8 - 7.9
Cord Grip Dome Nut	1-1/16" Dome Nut for Cord Grip	2X 1-1/16" Wrench, hold the cord grip body while tightening the dome nut	3.3 - 4.5	4.5 - 6.1
			or until cord does not slip	

Table 2b. Torque Specification: Models A-H

Fastener	Screw Size	Tool Required	*Recommended Seating Torque	
			ft-lbf	N-m
Motor Housing / Gear Housing / Back Frame Screws	1/4"-20 Socket Head Cap Screw	3/16" Hex Driver	7.9 - 8.3	10.7 - 11.3
Liftwheel Nut	1"-12 Hex Nut	1-1/2" - 6 or 12 Point Socket	55.0 - 60.0	74.6 - 81.3
Brake Mounting Screws	M4 Socket Head Cap Screw	3mm Hex Driver	2.5 - 3.3	3.4 - 4.5
Suspension Adapter Screws	3/8"-16 - 12-Point Cap Screw	3/8" - 12 Point Socket	35.0 - 45.0	47.5 - 61.0
Lower Hook Block Screws (Double Reeved)	1/4"-20 Socket Head Cap Screw	3/16" Hex Driver	5.0 - 5.8	6.8 - 7.9
Loose End Screw	1/4"-20 Socket Head Cap Screw	3/16" Hex Driver	4.2 - 5.0	5.6 - 6.8
Chain Stop Screw	1/4"-20 Socket Head Cap Screw	3/16" Hex Driver	5.0 - 5.8	6.8 - 7.9

*All Torque values are for clean, dry fasteners. DO NOT apply oil or any other lubricant to the fastener threads

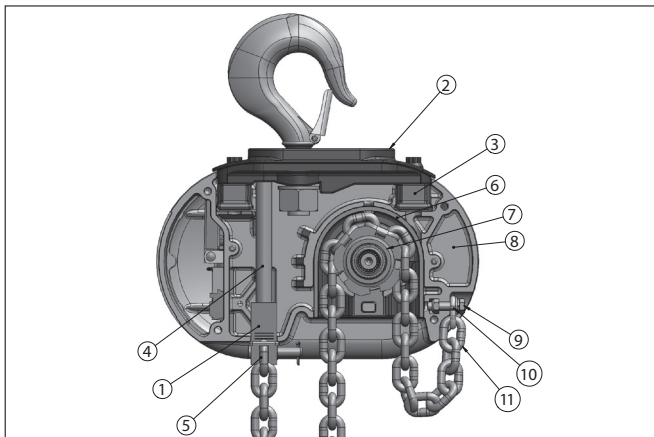

Figure 7. Attaching Load Chain Double Reeved Models

- ①. Dead end block
 - ②. Suspension assembly
 - ③. Suspension self-locking nut
 - ④. Dead end bolt
 - ⑤. Dead end link
 - ⑥. Chain guide
 - ⑦. Liftwheel
 - ⑧. Motor housing
 - ⑨. Loose end screw
 - ⑩. Loose end link
 - ⑪. Loose end
- (Do not order parts by these numbers. See parts list)

POWER SUPPLY AND ELECTRICAL CONNECTIONS

The hoist should be connected to a branch circuit which complies with the requirements of the National Electrical Code and applicable local codes.

For grounding of the hoist, the power cord includes a grounding conductor (green yellow, G-Y). Before connecting the hoist to the power supply, check that the power to be used agrees with the voltage range of the hoist. The nominal hoist voltage rating corresponding to the voltage range given on hoist identification plate is:

Table 3. Voltage Ranges

Range	Nominal
200-240	230
380-480	460

THREE PHASE HOIST

All Lodestar VS hoists operate on 3 phase power.

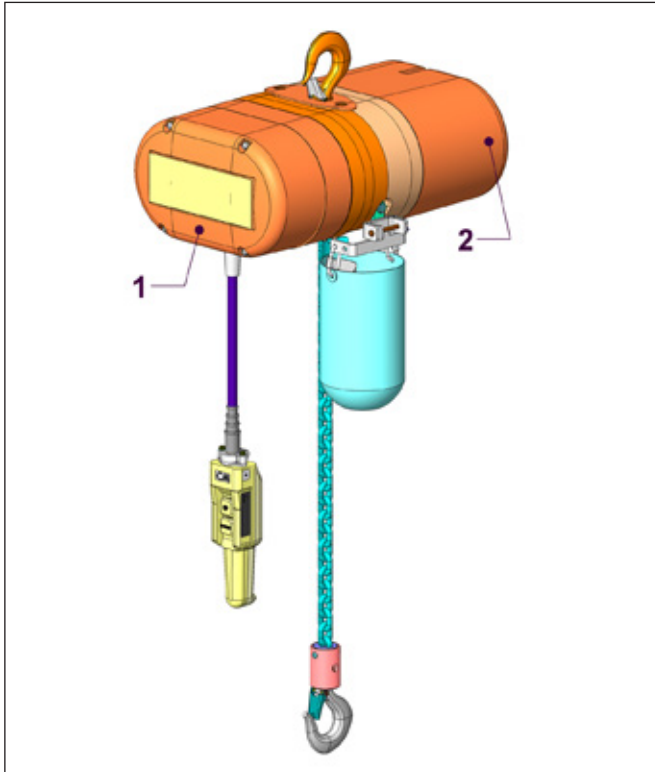

Figure 8. Location of Components

Variable Frequency Drive is located under back frame cover (1) for Models A-H.

POWER PHASING

The Lodestar VS will automatically correct for power supply phasing. If after a repair the hoist is running in the wrong direction, it should be corrected by correcting the motor output connections at the VFD.

NOTE: Serious damage can result if the hook is run to the upper or lower limit of travel with the hook operating in a direction opposite to that indicated by the control station. Therefore, proceed as follows:

1. Make temporary connections at the power supply.
2. Operate (UP) control momentarily. If hook raises, connections are correct and can be made permanent.
3. If hook lowers, it is necessary to change direction by correcting the motor output connections (T1,T2,T3) at the VFD. Consult the wiring diagram. Disconnect power before making any wiring changes.

Do not force the Lodestar Load-limiter to compensate for improperly adjusted limit switches or reverse voltage phasing.

⚠ WARNING
Working in or near exposed energized electrical equipment presents the danger of electric shock.
TO AVOID INJURY: DISCONNECT POWER AND LOCKOUT/TAGOUT DISCONNECTING MEANS BEFORE REMOVING COVER OR SERVICING THIS EQUIPMENT.

⚠ WARNING
Allowing the hook block to run into the bottom of the hoist when raising a load or allowing the chain to become taut between the loose end screw and the frame when lowering a load may break the chain and allow the load to drop.
TO AVOID INJURY: Do not allow the hook block to contact the bottom of the hoist or the loose end chain to become taut.

CHECKING FOR TWIST IN LOAD CHAIN MODELS E AND H.

The best way to check for this condition is to run the lower hook, without a load, up to within about 2 feet (.61 meters) of hoist. If the dead end of the chain has been properly installed, a twist can occur only if the lower hook block has been capsized between the strands of chain. Reverse capsize to remove twist.

CHECKING FOR ADEQUATE VOLTAGE AT HOIST

The hoist must be supplied with adequate electrical power in order to operate properly. For proper operation, the voltage, (measured at the hoist end of the standard power cord with the hoist operating in the, up direction with full load) must be as indicated in the table below.

Table 4. Minimum Running Voltage

Nominal Voltage	Minimum Running Voltage
230VAC	170VAC
460VAC	323VAC

SIGNS OF INADEQUATE ELECTRICAL POWER (LOW VOLTAGE) ARE:

- Noisy hoist operations due to brake chattering.
- Dimming of lights or slowing of motors connected to the same circuit.
- Heating of the hoist motor and other internal components as well as heating of the wires and connectors in the circuit feeding the hoists.
- Failure of the hoist to lift the load due to motor stalling.
- Blowing of fuses or tripping of circuit breakers.

⚠ WARNING
Failure to properly ground the hoist presents the danger of electric shock.
TO AVOID INJURY: Permanently ground the hoist as instructed in this manual.

To avoid these low voltage problems, the hoist must be connected to an electrical power supply system that complies with the National Electrical Code and applicable local codes. This system must also provide (slow blow fuses or inverse-time type circuit breakers) and provisions for grounding the hoist.

Low voltage may also be caused by using an undersized cord and/or connectors to supply power to the hoist. The following chart should be used to determine the size wires in the extension cord in order to minimize the voltage drop between the power source and the hoist.

Table 5. Minimum Wire Size

Length of Extension Cord	Minimum Wire Size
UP TO 200 FEET	#14 AWG
BEYOND 200 FEET	CONTACT FACTORY

⚠ WARNING
Failure to provide a proper power supply system for the hoist may cause hoist damage and offers the potential for a fire.
TO AVOID INJURY:
Provide each hoist with a 20 amp, minimum, overcurrent protected power supply system per the National Electrical Code and applicable local codes as instructed in this manual.

Remember, operation with low voltage can void the CM repair/replacement policy. When in doubt about any of the electrical requirements, consult a qualified electrician.

⚠ WARNING
Working in or near exposed energized electrical equipment presents the danger of electric shock.
TO AVOID INJURY:
DISCONNECT POWER AND LOCKOUT/TAGOUT DISCONNECTING MEANS BEFORE REMOVING COVER OR SERVICING THIS EQUIPMENT.

CHECKING LIMIT SWITCH (EPLS) OPERATION

The limit switch will automatically stop the hook at any predetermined point when either hoisting or lowering.

⚠ WARNING
Allowing the hook block to run into the bottom of the hoist when raising a load or allowing the chain to become taut between the loose end screw and the frame when lowering a load may break the chain and allow the load to drop.
Do not allow the hook block to contact the bottom of the hoist or the loose end chain to become taut.

Operate hoist over the entire length of its rated lift, checking upper and lower limit switches for correct operation as follows:

4. Press(UP) control and raise the lower hook until top of hook block is about one foot (305 mm) below the hoist.
5. Cautiously continue raising the hook until the upper limit switch stops the upward motion. The upper limit switch is set at the factory to stop the hook block 3 inches (76.2 mm) from bottom of the hoist on all units with standard 10 foot (3m) lift except Model AA. Factory setting is 6 inches (152.4 mm) for this model and for all other models equipped with chain for lifts longer than 10 feet (3m).
6. If adjustment is necessary, see page 18.
7. Press (DOWN) control and cautiously lower hook until lower limit switch stops the downward motion From 7 to 11 chain links (depending on hoist model) should be between the loose end link and the hoist entry. See Figure 7.
8. If adjustment is necessary, see page 18.

NOTE: If the hoist is equipped with a chain container/ bag, reset the upper and lower limit switches as indicated on page 18.

Under no condition should the hook block or load be permitted to come in contact with the chain container/bag. If contact is made, the function of the chain container can be interfered with and its fasteners imperiled.

NOTE: When chain bag is filled to capacity the bag must be no more than 75% filled.

NOTE: If the hoist gears ever rotate without encoder input to the drive, either due to encoder or wiring failure, or due to maintenance or disassembly of the hoist, the limits must be reset as described on page 18.

CONTROL CORD

Unless ordered on a special basis, the hoist is supplied with a control cord that will position the control station approximately 4 feet above the lower hook when it is at the lower limit of the lift. If this places the control station too close to the floor, a “control cord alteration kit” (Part Number 28642) can be obtained from CM for shortening the length of the control cord.

⚠ WARNING
Tying knots or loops to shorten the drop of the control station will make the strain relief ineffective and the internal conductors of the cord may break
TO AVOID INJURY:
Shorten the control cord using the control cord alteration kit and the instructions provided with the kit.

OPERATING INSTRUCTIONS

GENERAL

1. The Load-limiter is designed to slip on an excessive overload. An overload is indicated when the hoist will not raise the load. Also, some clutching noise may be heard if the hoist is loaded beyond rated capacity. Should this occur, immediately release the (UP) control to stop the operation of the hoist. At this point, the load should be reduced to the rated hoist capacity or the hoist should be replaced with one of the proper capacity. When the excessive load is removed, normal hoist operation is automatically restored.

CAUTION: The Load-limiter is susceptible to overheating and wear when slipped for extended periods. Under no circumstance should the clutch be allowed to slip for more than a few seconds.

It is not recommended for use in any application where there is a possibility of adding to an already suspended load to the point of overload. This includes dumbwaiter (*see below) installations, containers that are loaded in mid-air, etc.

(* Refer to limitations on Page 3 concerning dumbwaiter applications.

2. All hoists are equipped with electronically programmable limit switches, which automatically stops the hook at any predetermined point when either hoisting or lowering.
3. Rated lifting speeds are shown on hoist identification plate. SLOW speed is intended as a means of carefully controlling or “spotting” the load, although the hoist may be operated solely at this speed if desired. It is not necessary to operate in the SLOW speed position as the hoist will pick up a capacity load at FAST speed from a standing start. In other words, it is not necessary to

hesitate at the slow position when moving control from STOP to FAST position or vice versa.

4. If material being handled must be immersed in water, pickling baths, any liquid, dusty or loose solids, use a sling chain of ample length so that the hook is always above the surface. Bearings in the hook block are shielded only against ordinary atmospheric conditions.

HOIST

1. Before picking up a load, check to see that the hoist is directly overhead.
2. WHEN APPLYING A LOAD, IT SHOULD BE DIRECTLY UNDER HOIST OR TROLLEY. AVOID OFF CENTER LOADING OF ANY KIND.
3. Take up a slack load chain carefully and start load easily to avoid shock and jerking of hoist load chain. If there is any evidence of overloading, immediately lower the load and remove the excess load.
4. DO NOT allow the load to swing or twist while hoisting.
5. DO NOT allow the load to bear against the hook latch. HOIST WITH LOW HEADROOM TROLLEY

This unit should be moved by pushing on the suspended load or by pulling the empty hook. However, the unit can also be moved by pulling on the control station since an internal steel cable extends the length of the control cord and is anchored to the hoist and to the control station.

HOIST WITH MOTOR DRIVEN TROLLEY

This unit should be moved by operating the controls marked (Forward) and (Reverse) in control station. Unless altered by the erector, depressing (Forward) control will move the hoist toward motor housing end. Anticipate the stopping point and allow trolley to coast to a smooth stop. Reversing or “plugging” to stop trolley causes overheating of motor and swaying of load.

SAFE OPERATING INSTRUCTIONS AND PROCEDURES

For safety precautions and a list of Do’s and Do Not’s for safe operation of hoists, refer to page 3.

6. Permit only competent personnel to operate unit.
7. When preparing to lift a load, be sure that the attachments to the hook are firmly seated in hook saddle. Avoid off center loading of any kind, especially loading on the point of hook.
8. **DO NOT** allow the load to bear against the hook latch. The latch is to help maintain the hook in position while the chain is slack before taking up slack chain.

 WARNING
Allowing the load to bear against the hook latch and/or hook tip can result in loss of load.
TO AVOID INJURY:
Do not allow the load and/or attachments to bear against the hook latch and/or hook tip. Apply load to hook bowl or saddle only.

9. **DO NOT** wrap the load chain around the load and hook onto itself as a choker chain.

Doing this will result in:

- a. The loss of the swivel effect of the hook

which could result in twisted chain and a jammed liftwheel.

- b. The upper limit switch is by-passed and the load could hit the hoist.
 - c. The chain could be damaged at the hook.
10. Before lifting load, check for twists in the load chain. On double and triple reeved units, a twist can occur if the lower hook block has been capsized between the strands of chain. Reverse the capsize to remove twist.
 11. Stand clear of all loads and avoid moving a load over the heads of other personnel. Warn personnel of your intentions to move a load in their area.
 12. **DO NOT** leave the load suspended in the air unattended.
 13. **DO NOT** use this or any other overhead materials handling equipment for lifting persons.
 14. **DO NOT** load hoist beyond the rated capacity shown on ID plate. When in doubt, use the next larger capacity CM Lodestar Hoist.
 15. Warn personnel of your intention to lift a load in the area. Tie off the load with auxiliary chains or cables before access to the area beneath the load is permitted.
 16. Take up a slack load chain carefully and start load easily to avoid shock and jerking of hoist load chain. If there is any evidence of overloading, immediately lower the load and remove the excess load.
 17. When lifting, raise the load only enough to clear the floor or support and check to be sure that the attachments to the hook and load are firmly seated. Continue lift only after you are assured the load is free of all obstructions.
 18. **DO NOT** allow the load to swing or twist while hoisting.
 19. Never operate the hoist when flammable materials or vapors are present. Electrical devices produce arcs or sparks that can cause a fire or explosion.
 20. **STAY ALERT!** Watch what you are doing and use common sense. Do not use the hoist when you are tired, distracted or under the influence of drugs, alcohol or medication causing diminished control.

THERMOCHROMIC LABELS

This hoist is equipped with special thermochromic labels that change color in response to temperature. When the area under the label exceeds 130 degrees F, the label will transition from orange to white, revealing the word “HOT”. When the hoist cools down, the warning will disappear. Over time, the label may lose its effectiveness, and eventually will always say “HOT”. For your own safety, always treat any hoist parts as hot before handling them, and wear gloves when handling a hoist that was recently in use.

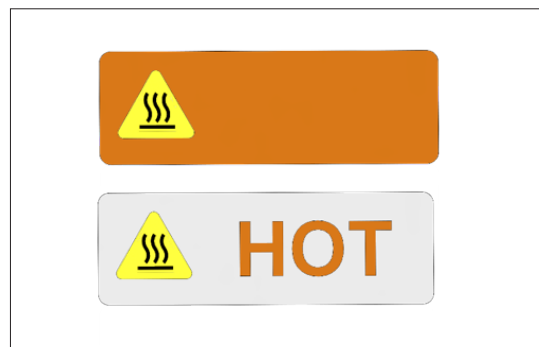

INSPECTION

To maintain continuous and satisfactory operation, a regular inspection procedure must be initiated to replace worn or damaged parts before they become unsafe. Inspection intervals must be determined by the individual application and are based on the type of service to which the hoist will be subjected.

The type of service to which the hoist is subjected can be classified as "Normal", "Heavy", or "Severe".

Normal Service:

Involves operation with randomly distributed loads within the rated load limit, or uniform loads less than 65 percent of rated load for not more than 25 percent of the time.

Heavy Service:

Involves operating the hoist within the rated load limit which exceeds normal service.

Severe Service:

Normal or heavy service with abnormal operating conditions or constant exposure to the elements of nature.

Two classes of inspection - frequent and periodic - must be performed.

Frequent Inspections:

These inspections are visual examinations by the operator or other designated personnel. Records of such inspections are not required. The frequent inspections are to be performed monthly for normal service, weekly to monthly for heavy service, and daily to weekly for severe service, and they should include those items listed in Table 7.

Periodic Inspections:

These inspections are visual inspections of external conditions by an appointed person. Records of periodic inspections are to be kept for continuing evaluation of the condition of the hoist.

Periodic inspections are to be performed yearly for normal service, semi-annually for heavy service and quarterly for severe service, and they are to include those items listed in Table 8.

CAUTION: Any deficiencies found during inspections are to be corrected before the hoist is returned to service. Also, the external conditions may show the need for disassembly to permit a more detailed inspection, which, in turn, may require the use of nondestructive type testing

PREVENTATIVE MAINTENANCE

In addition to the above inspection procedure, a preventive maintenance program should be established to prolong the useful life of the hoist and maintain its reliability and continued safe use. The program should include the periodic and frequent inspections with particular attention being paid to the lubrication of the various components using the recommended lubricants (see page 57).

SUSPENSION INSPECTION CRITERIA

BRACKETS - Replace any brackets found to be cracked or distorted.

BOLTS - If the suspension is removed for any reason, including inspection, the suspension bolts should be replaced.

NYLON THREAD LOCKING NUTS - It is not necessary to replace the nylon thread locking nuts each time the suspension bolts are replaced as long as new bolts with the locking patch are being used. It is recommended that the nylon thread locking nuts are replaced each time the hoist is torn down to allow these nuts to be replaced.

HOOK REMOVAL CRITERIA

Based on B30-10 Hooks shall be removed from service if damage such as the following is visible and shall only be returned to service when approved by a qualified person:

- Missing or illegible rated load identification or illegible hook manufacturers' identification or secondary manufacturer's identification.
- Excessive pitting or corrosion.
- Cracks, nicks, or gouges.
- Wear--any wear exceeding 10% of the original section dimension of the hook or its load pin.
- Deformation--any visibly apparent bend or twist from the plane of the unbent hook.
- Throat opening--any distortion causing an increase in the throat opening of 5% not to exceed 1/4" (6mm).
- Inability to lock - any self-locking hook that does not lock.
- Inoperative latch any damaged latch or malfunctioning latch that does not close the hook's throat.
- Thread wear, damage, or corrosion.
- Evidence of excessive heat exposure or unauthorized welding.
- Evidence of unauthorized alterations such as drilling, machining, grinding, or other modifications.

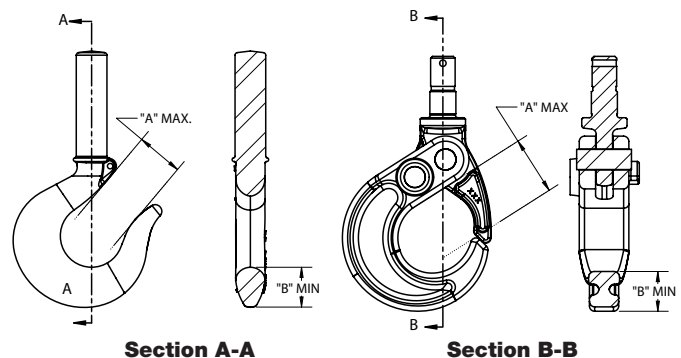

Figure 9. Hook Inspection

Table 6. Hook Inspection Dimensions

Models	Latch Type Hook		Latchlok® Hook	
	"A" Max	"B" Min	"A" Max	"B" Min
A, AA, B, C & F	1.19" (30.2mm)	.91" (23.1mm)	1.48" (37.7mm)	.75" (18.8mm)
E & H	1.31" (33.3mm)	1.08" (27.5mm)	1.48" (37.7mm)	.75" (18.8mm)

Table 7. Minimum Frequent Inspections			
TYPE OF SERVICE			ITEM
Normal	Heavy	Severe	
Monthly	Weekly to Monthly	Daily to Weekly	a) Brake for evidence of slippage.
			b) Control functions for proper operation.
			c) Hooks for damage, cracks, twists, excessive throat opening, latch engagement and latch operation - see page 14.
			d) Load chain for adequate lubrication, as well as for signs of wear, damaged links or foreign matter - see page 17.
			e) Load chain for proper reeving and twists.

Table 8. Minimum Periodic Inspections			
TYPE OF SERVICE			ITEM
Normal	Heavy	Severe	
			a) All items listed in Table 7 for frequent inspections.
Yearly	Every 6 Months	Every 3 Months	b) External evidence of loose screws, bolts or nuts.
			c) External evidence of worn, corroded, cracked or distorted hook block, suspension screws, gears, bearings and dead end block and chain pin.
			d) External evidence of damage to hook retaining nut and pin. Also check the upper suspension adapter making sure it is fully seated in the hoist frame and that both screws are tight.
			e) External evidence of damage or excessive wear of the liftwheel and hook block sheave chain pockets. Widening and deepening of the pockets may cause the chain to lift-up in the pocket and result in binding between liftwheel and chain guides or between the sheave and hook block. Also, check the chain guide for wear or burring where the chain enters the hoist. Severely worn or damaged parts should be replaced.
			f) External evidence of excessive wear of brake parts - see page 17.
			g) External evidence of pitting or any deterioration of contactor contacts. Check the operation of the control station making sure the buttons operate freely and do not stick in either position.
			h) Inspect the electrical cords and cables and control station enclosure for damaged insulation.
			i) Inspect trolley trackwheels for external wear on tread and flange and for wear on internal bearing surfaces as evidenced by a looseness on the stud. Suspension components for damage, cracks, wear and operation. Also check suspension adapter screws for proper tightness - see page 9.
			j) Inspect the loose end link, loose end screw and dead end block on double reeved units. Replace worn or distorted parts.
			k) Inspect the suspension lug or hook for excess free play or rotation. Replace worn parts as evidenced by excess free play or rotation.
			l) Inspect for signs of lubricant leaks at the gasket between the gear housing and back frame. Tighten screws holding back frame to gear housing. If leak persists, repack housing and gears with grease and install a new gasket.

INSPECTING THE LOAD CHAIN:

The chain must be inspected at regular intervals, with a minimum of once annually. As the frequency of use increases, the time intervals between inspections must be reduced. During inspection, the chain must be examined along their entire length, including the hidden parts. If the lifting equipment is frequently used with a constant lifting distance or in other words the switch from upward to downward often takes place in the same area, a particularly thorough inspection and lubrication is required in that area. Worn chain can be an indication of worn hoist components. For this reason, the hoist's chain guides, hook blocks and liftwheel (sprocket) should be examined for wear and replaced as necessary when replacing chain.

1. Check to see if chain is dirty or poorly lubricated.
2. Clean the chain with a non-caustic/non-acid type solvent and make a link by link inspection for wear or cracks in the links, twisted or deformed links. Chain with any one of these defects must be replaced.
3. Slack the portion of the chain that normally passes over the liftwheel (sprocket) or idler sprocket on multi-reeved hoist. Examine the chain links for wear (see figure 10). If the wire diameter anywhere on the link measures less than 90% of the nominal wire diameter, the chain must be replaced.

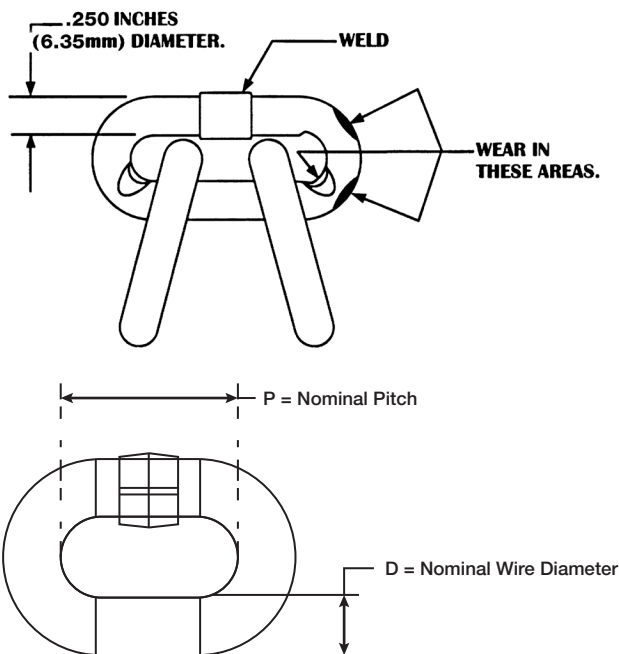

Figure 10. Chain Wear Areas

Table 9. Chain Dimensions

Models	P	D
A, AA, B, C, E, F, H	.745" (18.9mm)	.250" (6.3mm)

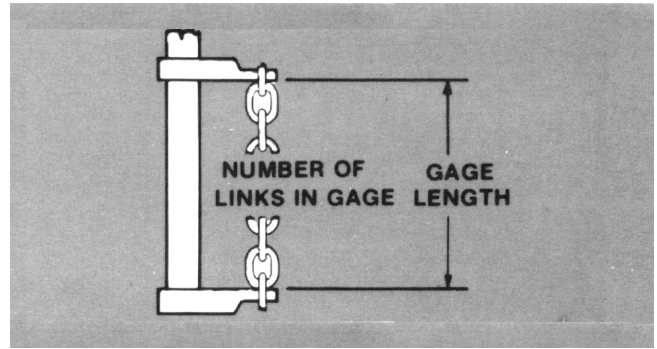

Figure 11. Gaging Load Chain Wear

4. Based upon ASME B30.16, 2012 chain should also be checked for elongation. Select an unworn, un-stretched length of the chain (at the slack end for example). Suspend the chain vertically under tension and using a knife blade caliper type gauge, measure the outside length of any convenient number of links, 11 is recommended. Measure the same number of links in the used sections and calculate the percentage in increased length. The chain should be replaced if the length of the used portion is more than 2% longer than the unused portion of the chain. Also, if the pitch of any individual link has elongated by more than 5%, the chain should be replaced.

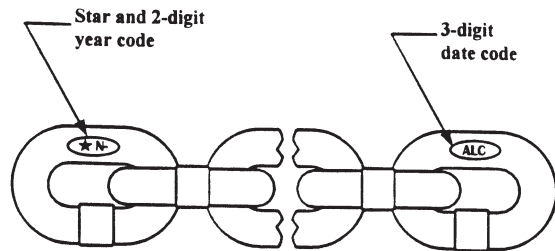

Figure 12. Chain Embossing

Use only Star (*) grade load chain and original replacement parts. Use of other chain and parts may be dangerous and voids factory warranty.

IMPORTANT: Do not use replaced chain for other purposes such as lifting or pulling. Load chain may break suddenly without visual deformation. For this reason, cut replaced chain into short lengths to prevent use after disposal.

WARNING

Use of commercial or other manufacturer's chain and parts to repair CM hoists may cause load loss.

TO AVOID INJURY:

Use only CM supplied replacement load chain and parts. Chain and parts may look alike, but CM chain and parts are made of specific material or processed to achieve specific properties.

MAINTENANCE

LOAD-LIMITER

The Load-limiter should operate for the normal life of the hoist without service. The device has been calibrated at the factory for a specific model of hoist. For proper overload protection, be sure before installing a Load-limiter that it is correct for the unit.

Table 10. Load Limiter Part Numbers

Models	Load-Limiter Part Number	Load-Limiter ID (marked on Load-limiter)
A, B, E	C00000240	240
AA, C, F, H	C00000241	241

WARNING

The lubricants used in and recommended for the Lodestar Hoist may contain hazardous materials that mandate specific handling and disposal procedures.

TO AVOID CONTACT AND CONTAMINATION:

Handle and dispose of lubricants only as directed in applicable material safety data sheets and in accordance with applicable local, state and federal regulations.

HOIST LUBRICATION

GEARS

NOTE: To assure extra long life and top performance, be sure to lubricate the various parts of the Lodestar Hoist using the lubricants specified. If desired, these lubricants may be purchased from CM. Refer to Table of Contents for information on ordering the lubricants.

The gearbox is packed at assembly with grease and should not need to be renewed unless the gears have been removed from the housing and degreased.

If the gears are removed from the housing, wipe the excess grease off with a soft cloth and degrease the gears and housings. Upon reassembly, add grease to gears and housing.

Models A to H hoists require 7 fl. oz. of grease.

Also, coat the spline on the end of the drive shaft with a Molydisulphide lubricant such as "Super Herculon".

BEARINGS

- All bearings and bushings, except the lower hook thrust bearing, are pre-lubricated and require no lubrication. The lower hook thrust bearing should be lubricated at least once a month.

CHAIN GUIDES, LIFTWHEEL AND LOWER SHEAVE WHEEL

- When the hoist is disassembled for inspection and/ or repair, the chain guides, lower sheave wheel (on double chain units) and liftwheel must be lubricated with Lubriplate Bar and Chain Oil 10-R (Fiske Bros. Refining Co. or equivalent) prior to reassembly. The lubricant must be applied in sufficient quantity to obtain natural runoff and full coverage of these parts.

LOAD CHAIN

A small amount of lubricant will greatly increase the life of load chain. Do not allow the chain to run dry.

Keep it clean and lubricate at regular intervals with Lubriplate Bar and Chain Oil 10-R (Fiske Bros. Refining Co.) or equal lubricant. Normally, weekly lubrication and cleaning is satisfactory, but under hot and dirty conditions, it may be necessary to clean the chain at least once a day and lubricate it several times between cleanings.

When lubricating the chain, apply sufficient lubricant to obtain natural run-off and full coverage, especially in the interlink area.

WARNING

Used motor oils contain known carcinogenic materials

TO AVOID HEALTH PROBLEMS:

Never use used motor oils as a chain lubricant. Only use Lubriplate Bar and Chain Oil 10-R as a lubricant for the load chain.

TROLLEY LUBRICATION

See appropriate trolley manual.

EXTERIOR FINISH

The exterior surfaces of the hoist and trolleys have a durable, scratch resistant baked powder coating. Normally, the exterior surfaces can be cleaned by wiping with a cloth. However, if the finish is damaged, compatible touch-up paint can be purchased from CM. Refer to page 57 for information on ordering the paint.

TEMPERATURE RATING

Normal ambient operating temperature, unless otherwise specified, range from 0°F to 104°F(-17 to 40°C). Contact factory for ambient temperature solutions outside this stated range.

BRAKE ADJUSTMENTS

DC ELECTRIC BRAKE ASSEMBLY

The correct air gap between field and armature is .008-.018 in (0.2-0.45 mm) for models A through H. The DC brake is not adjustable. As the friction material wears, the brake gap increases. If the maximum air gap is reached, a new friction disc/rotor should be installed.

LIMIT SWITCH (EPLS) ADJUSTMENTS

If limit switch operation has been checked as described on page 12 and is not operating correctly or is not automatically stopping the hook at a desired position, proceed as follows:

1. Disconnect hoist from power supply.
2. Remove the back frame cover.
3. Reconnect the hoist to the power supply.

SETTING UPPER LIMIT SWITCH

1. The "A" Dimensions given in Table 11 are the minimum distance that should be set between the top at hook block and the bottom of the hoist.
2. Operate the hoist in the up direction until the hook block is at the desired upper limit position. CAUTION: actual limit position may vary from initial set position. See dimension "C" in table 11.
3. Navigate to parameter C3.12 of the VFD (see programming section).
4. Change the value to "2" and press enter.
5. Exit programming mode.
6. Check upper limit function and position. If adjustment is desired, refer to the "C" dimension to determine the minimum adjustment from the current setting.
7. Repeat steps 2-6 as necessary to achieve desired limit position.
8. Set lower limit.

CAUTION: THE "A" DIMENSIONS ARE THE MINIMUM ALLOWED FOR SAFE OPERATION AND SHOULD NOT BE REDUCED.

SETTING LOWER LIMIT SWITCH

1. Refer to Table 6 -The "B" dimensions given are the minimum length of loose end chain left on the non-load side of the liftwheel when the hook is positioned at the lowest allowable hook position.
2. Operate the hoist in the down direction until the hook block is at the desired lower limit position. CAUTION: actual limit position may vary from initial set position. See dimension "C" in table 11.
3. Navigate to parameter C3.12 of the VFD (see programming section).
4. Change the value to "3" and press enter.
5. Exit programming mode.
6. Check lower limit function and position before placing the unit into service. If adjustment is desired, refer to the "C" dimension to determine the minimum adjustment from the current setting.
7. Repeat steps 2-6 as necessary to achieve desired limit position.
8. Disconnect the hoist from the power supply.
9. Re-install the end cover.

CAUTION: THE "B" DIMENSIONS ARE THE MINIMUM ALLOWED FOR SAFE OPERATIONS AND SHOULD NOT BE REDUCED.

SLOW APPROACH

The Lodestar VS slow approach function will automatically slow down to 1/3 of normal 60Hz speed when the hook approaches one of the hook travel limits. This offers operators a warning that they are approaching the final hoist limit. This feature is enabled by default from the factory. This feature can be enabled or disabled by setting C03-22 to 1 or 0, respectively.

Table 11. Limit Switches

Models	A (minimum distance between top of hook and bottom of hoist)		B (minimum distance between top of loose end chain stop and bottom of hoist)		C (increment between available limit set positions)	
	in	mm	in	mm	in	mm
A, C	3	76.2	3	76.2	2	50.8
AA	6	152.4	6	152.4	3.75	95.25
B, F	1.5	38.1	1.5	38.1	1	25.4
E, H	1.5	38.1	1.5	38.1	0.5	12.7

PROGRAMMING THE ADJUSTABLE FREQUENCY DRIVE

Using The Keypad

All functions of the drive are accessed using the keypad. The information needed to configure the drive's application is entered into the drive by using the functional LEDs. This information is stored into the drive's memory.

Keypad Functions

The keypad has a 5-digit LED display. Both numeric and alpha-numeric data can appear on the display.

Indicators and keys on the keypad are described below.



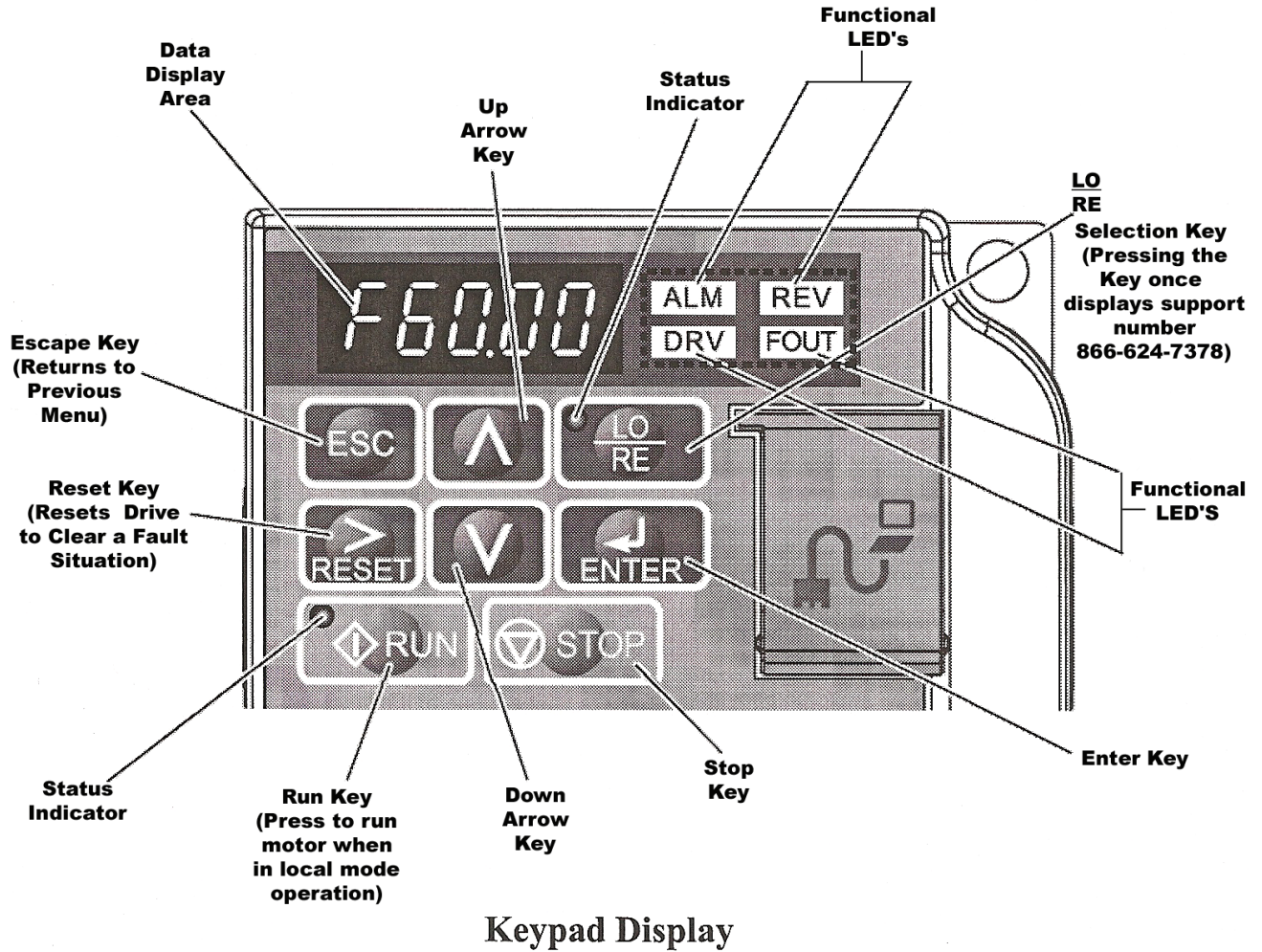





Note: The STOP key is always active and will cause any run command to come to an immediate stop.





KEYPAD LED AND BUTTON FUNCTIONS

Some of the keypad buttons, whose functions are described below, are dual-purpose. The dual- purpose keys have one function when used in a view-only mode and another function when used in a programming mode.:





KEYS AND DISPLAYS ON THE LED OPERATOR

NO.	DISPLAY	NAME	FUNCTION
1		Data Display Area	Displays the frequency reference, parameter number, etc.
2		ESC Key	Return to the previous menu (before ENTER Key is pressed), or cursor position
3		RESET Key	Moves the cursor to the right. Resets the drive to clear a fault situation
4		RUN Key	Pressing the key initiates the RUN command when LOCAL mode operation is selected. Starts the auto-tuning process.
5		Up Arrow Key	Scrolls up to select next parameter group or parameter settings. It also increases the value of the blinking digit of a parameter setting.
6		Down Arrow Key	Scrolls down to select next parameter group or parameter settings. It also decreases the value of the blinking digit of a parameter setting.
7		STOP Key	Stops the drive by initiating a base block STOP command. Note: Stop priority circuit.
8		ENTER Key	Selects modes or parameters. Displays each parameter's set value. By pressing this key again, the set value is stored.
9		LO/RE Key	Pressing the key once displays support phone number 866-624-7378. Pressing the key again shows control method, motion and reference speed. Pressing the key again will show RESET. Pressing the ENTER Key afterwards will reset the maintenance timers.

LO/RE LED AND RUN LED INDICATIONS

NO.	LED	Lit	Flashing	Flashing Quickly	OFF
10		During run.	During deceleration to stop. When a run command is input and frequency is 0.	During deceleration at a fast stop. During stop by interlock operation	During stop.
11		When run command is selected from LED operator (LOCAL)	—	—	Run command is selected from device other than LED operator (REMOTE)

FUNCTION LEDS

NO.	Display	Lit	Flashing	OFF
12		When the drive detects an alarm or error	When an alarm occurs OPE detected When a fault or error occurs during Auto-Tuning	Normal state (no fault or alarm)
13		When the REVERSE command is given	—	When the FORWARD command is given
14		Drive Ready Auto-Tuning	—	Programming Mode
15		Displays output frequency (Hz)	—	—

PARAMETERS

There are hundreds of parameters, organized by function group, that determine how the drive functions. These parameters are programmed in the drive's software as measurable values or options-both of which will be referred to in this manual as settings. While some of these parameters are associated with one setting, others are tied to a number of possible settings.

The IMPULSE•G+ Mini is configured for a specific hoist or trolley. If you find it necessary to change the initial settings, it is recommended that you only allow qualified system technicians to program the drive. This can be accomplished by using the Password and Access Level features. The factory must be contacted.

IMPULSE•G+ MINI STRUCTURE OF PARAMETERS

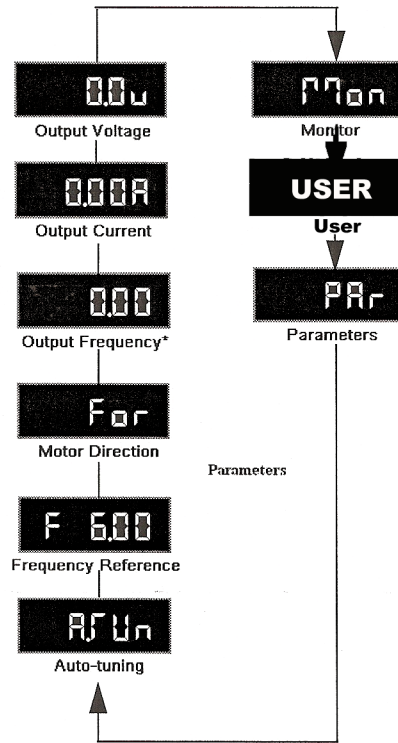

Frequency Reference Setting

Sets/Displays the drive operation speed (Hz).

Output Frequency Monitor

Displays the output frequency (Hz.) at which the drive is currently operating. This is a monitor only function; the operator cannot change the displayed value by use of the keypad.

Output Current Monitor

Displays the level of output current (Amps) that the drive is currently producing. This is a monitor only function; the operator cannot change the displayed value by use of the keypad.

Monitor Selection

Pressing ENTER allows access to the various Monitor parameters. These are monitor-only functions; the operator cannot change the displayed value. Accessible during run command. See pages 21 thru 26 for complete listing of all monitor parameters.

*Parameter Programming

Selects or reads data using parameter settings. Data is displayed by pressing the ENTER key, and can be changed by pressing the “up arrow” or “down arrow” keys. Any changes can be saved by again pressing the ENTER key. Pressing the ESC key exits the programming mode.

Output Voltage Monitor

Displays the level of output voltage to the motor. This is a monitor only function: The operator cannot change the displayed value by use of the keypad.

User

Allows for quick access to parameters that can be programmed by operator.

*Note: All programming parameters are password protected, except those stored in user function..

MONITOR PARAMETERS

PARAMETER CODE	NAME	FUNCTION	UNITS
MONITOR			
U01.01	Frequency Reference	Frequency Reference	Hz
U01.02	Output Frequency	Inverter Output Frequency	Hz
U01.03	Output Current	Inverter Output current	A
U01.04	Control method	Displays the value of A01.02	—
U01.05	Motor Speed	Motor Speed (OLV only)	—
U01.06	Output Voltage	Inverter Output Voltage (Reference)	V
U01.07	DC Bus Voltage	DC Bus Voltage (Measured)	V
U01.08	Output Power	Inverter Output Power (Calculated)	HP
U01.09	Motor Torque	Motor Torque (OLV only)	%
U01.10	Input Terminal	Status Input Terminal Status	—

U01.10

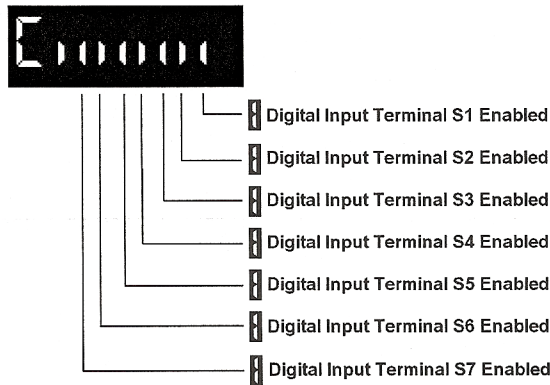

U01.11	Output Terminal Status	Output Terminal Status	—
--------	------------------------	------------------------	---

U01.11

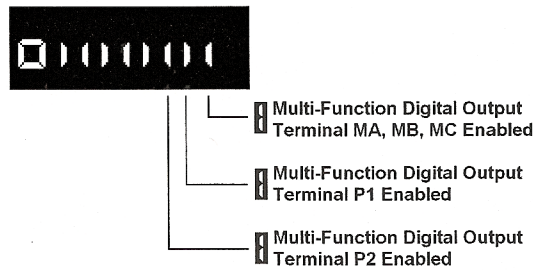

U01.12	Inverter Control Status	Operation Status	—
--------	-------------------------	------------------	---

U01.12

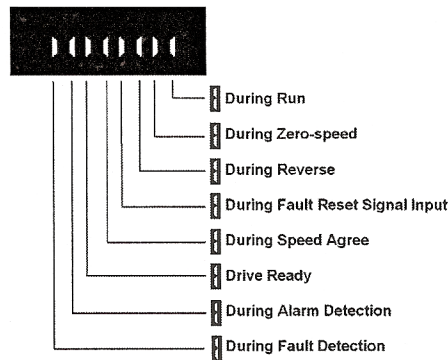

MONITOR PARAMETERS

Parameter Code	Name	Function	Units
Monitor			
U01.13	Elapsed Time	Elapsed Time	hours
U01.14	Flash ID	Flash ROM software ID number	--
U01.15	Terminal A1 Level	External Terminal input level	V
U01.16	Terminal A2 Level	External Terminal input level	V/mA
U01.20	Output Frequency after Soft Start	---	Hz
U01.28	Software CPU	---	--
U01.34	OPE Detection Parameter	Parameter OPE detected	const #
U01.39	Memobus Communications Error	Displays content of MEMOBUS error	--

U01.39

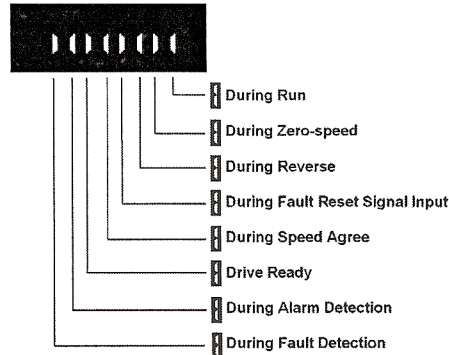

Parameter Code	Name	Function	Units
U01.52	Maintenance Timer		hr
U01.54	Pulse Monitor	Displays the pulse train input RP Frequency	--
Fault Trace			
U02.01	Current Fault Displays Current fault --		
U02.02	Last Fault Displays last fault detected --		
U02.03	Frequency Reference @ Fault	Frequency reference when fault was detected	Hz
U02.04	Output Frequency @ Fault	Output frequency when fault was detected	Hz
U02.05	Output Current @ Fault	Output current when fault was detected	A
U02.06	Motor Speed @ Fault (OLV Only)	Motor speed when fault was detected	Hz
U02.07	Output Voltage @ Fault	Output voltage when fault was detected	V
U02.08	DC Bus Voltage @ Fault	DC Bus voltage when fault was detected	V
U02.09	Output Power @ Fault	Output power when fault was detected	kW
U02.11	Input Terminal Status @ Fault	Input terminal status when fault was detected	--
U02.12	Output Terminal Status @ Fault	Output terminal status when fault was detected	--

MONITOR PARAMETERS

Parameter Code	Name	Function	Units
Fault Trace			
U02.13	Operation Status @ Fault	Inverter status before fault was detected	--
U02.14	Elapsed Time @ Fault	Elapsed time when fault was detected	hr
U02.15	Speed Reference During Soft Start @ Fault	Speed reference during soft start at previous fault	%
U02.16	Motor q-Axis Current During Fault	---	--
U02.17	Motr d-Axis Current During Fault	---	--
Fault History			
U03.01	Last Fault	Displays most recent fault --	
U03.02	Fault Message 2	Displays second most recent fault	--
U03.03	Fault Message 3	Displays third most recent fault	--
U03.04	Fault Message 4	Displays fourth most recent fault	--
U03.05	Fault Message 5	Displays fifth most recent fault	--
U03.06	Fault Message 6	Displays sixth most recent fault	--
U03.07	Fault Message 7	Displays seventh most recent fault	--
U03.08	Fault Message 8	Displays eight most recent fault	--
U03.09	Fault Message 9	Displays ninth most recent fault	--
U03.10	Fault Message 10	Displays tenth most recent fault	--
U03.11	Elapsed Time 1	Elapsed time of most recent fault	--
U03.12	Elapsed Time 2	Elapsed time of second most recent fault	--
U03.13	Elapsed Time 3	Elapsed time of third most recent fault	--
U03.14	Elapsed Time 4	Elapsed time of fourth most recent fault	--
U03.15	Elapsed Time 5	Elapsed time of fifth most recent fault	--
U03.16	Elapsed Time 6	Elapsed time of sixth most recent fault	--
U03.17	Elapsed Time 7	Elapsed time of seventh most recent fault	--
U03.18	Elapsed Time 8	Elapsed time of eight most recent fault	--
U03.19	Elapsed Time 9	Elapsed time of ninth most recent fault	--
U03.20	Elapsed Time 10	Elapsed time of tenth most recent fault	--
U03.21	Accumulated Operations	Displays the number of FWD and REV Commands	--
U03.22	U03.21 Rollovers	Increments when U03.21 reaches 65535. U03.21 is set to zero.	--
U03.23	Overload/Load Check Count	Displays the number of OL1, OL2 and LC faults	--
Maintenance			
U04.01	Cumulative Operation Time		hr
U04.03	Cooling Fan Operation Time		hr
U04.04	Cooling Fan Maintenance		%
U04.05	Capacitor Maintenance		%
U04.06	Soft Charge Bypass Relay Maintenance		%
U04.07	IGTB Maintenance		%
U04.08	Heatsink Temperature		--

MONITOR PARAMETERS

Parameter Code	Name	Function	Units
Maintenance			
U04.09	LED Check	Lights all segments of the LED to verify that the display is working properly	
U04.10	kWh: Lower 4 Digits		--
U04.11	kWh: Upper 5 Digits		--
U04.12	CPU Resources Used		--
U04.13	Peak Hold Current		--
U04.14	Peak Hold Output Frequency		--
U04.16	Motor Overload (oL1) Detection Level		--
U04.17	Motor Overload (oL2) Detection Level		--
U04.18	Frequency Reference Source Selection		--
U04.19	Frequency Reference Memobus		--
U04.20	Output Frequency Reference (decimal)		--
U04.21	Run Command Selection Results		--
U04.22	Memobus Communication Reference		--
U04.23	Not Used		--
Motor Control Monitor			
U06.01	Motor Secondary Current (Iq)		%
U06.02	Motor Excitation Current (Id)		%
U06.03	ASR Input		%
U06.04	ASR Output		%
U06.05	Output Voltage Reference (Vq)		%
U06.06	Output Voltage Reference (Vd)		%
U06.07	ACR (q) Output		%
U06.08	ACR (d) Output		%
U06.20	Frequency Reference Bias (Up/Down2)		%
U06.21	Offset Frequency		%
U06.36	GAIA Communication Error		--
U06.37	LUNA Communication Error		--
U06.38	Option Card Error		--

IMPULSE G+MINI ADJUSTABLE FREQUENCY DRIVE SPECIFICATIONS

Specification	Specification Value and Information for all Models
Certification	UL, cUL, CE, TÜV, RoHS
Rated input power supply volts & frequency	3-phase 200~240V or 380~480V: 50/60 Hz
Allowable input voltage fluctuation	+10% or -15% of nominal
Allowable input frequency fluctuation	±5% of nominal
Control method	Fully digital; sine-wave, pulse-width-modulated
Maximum output voltage (VAC)	Max output voltage 3-phase, 200~240V; 380~480V (proportional to input voltage).
Rated frequency (Hz)	Up to twice motor nameplate RPM (Swift-Lift) 60 Hz standard (150 Hz, consult factory)
Output speed control range	40:1 -V/f, 100:1 - Open Loop Vector (OLV)
Output frequency accuracy	0.01%-with digital reference command 0.1%-with analog reference command; 10 bits/10V
Frequency reference resolution	Digital: 0.01 Hz; analog: 0.03 Hz (at 60 Hz)
Output frequency resolution	0.01 Hz
Overload capacity	150% of rated output current of the drive for 1 minute
Remote frequency reference sources	0-10VDC (2K Ω); ±10VDC serial (RS-485)
Accel/decel times	0.0 to 25.5 seconds - 1 set; 0.0 to 6000.0 - 3 sets; 8 parameters are independently adjustable
Braking torque	150% or more with dynamic braking
Motor overload protection	UL recognized electronic thermal overload relay: field-programmable
Overcurrent protection level	200% of drive rated current
Circuit protection	Ground fault and blown-fuse protection
Overvoltage protection level	Approximately 410VDC (230V Class), 820VDC (460V Class)
Undervoltage protection level	Approximately 190VDC (230V Class), 380VDC (460V Class)
Heatsink overtemperature	Thermostat trips at 184 - 249°F (90 -121°C) dependent on drive capacity
Torque limit selection	Separate functions for FORWARD, REVERSE, REGEN.; all selectable from 0-300%
Stall prevention	Separate functions for accel, decel, at-speed and constant horsepower region
Other protection features	Lost output phase, failed-oscillator, mechanical overload and internal braking transistor
DC bus voltage indication	Charge LED is on until DC bus voltage drops below 50VDC
Location	Indoors; requires protection from moisture, corrosive gases and liquids
Ambient operating temperature	14° to 122°F (-10° to 50°C) for open chassis
Storage temperature	-4° to 140°F (-20° to 60°C)
Humidity	95% relative; noncondensing
Vibration	1G less than 20 Hz; 0.2 G for 20-55 Hz
Elevation	3300 Ft. (1000M) or less
Memobus	RS485/422 Max 115.2 Kbps

SPEED CONTROL METHODS

The IMPULSE.G+Mini provides 1-step, 2-step or 3-step Multi-Step control methods. For each input that is energized, the drive begins to operate at the corresponding frequency. If 1, 2 or 3-step is desired, then the frequency reference for the 1st, 2nd or 3rd step will be set at the maximum desired speed of operation.

2-Step/2-Speed Control

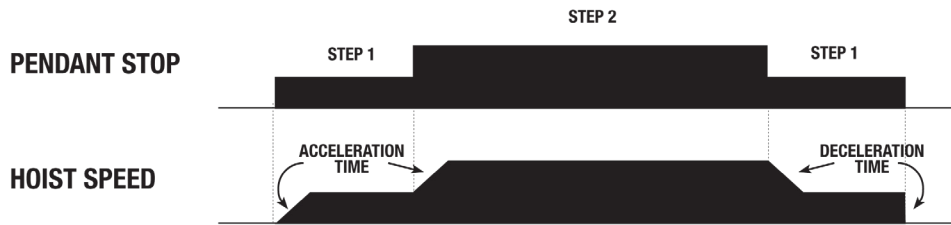

3-Step/3-Speed Control

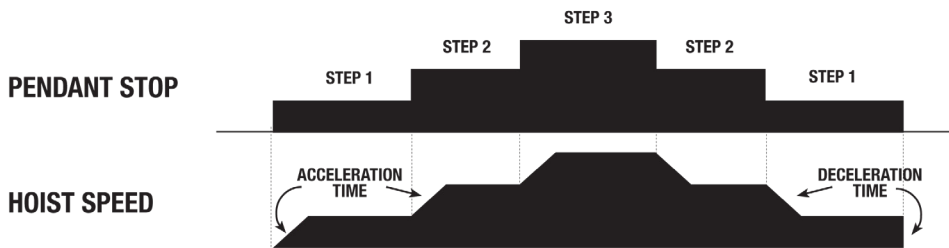

In addition to discrete speed control, true infinitely variable speed control can be configured. The IMPULSE.G+ Mini has two ways in which infinitely variable control can be configured, 2-Step Infinitely Variable and 3-Step Infinitely Variable control. Sample timing diagrams for both methods are given.

2-Step Infinitely Variable Control

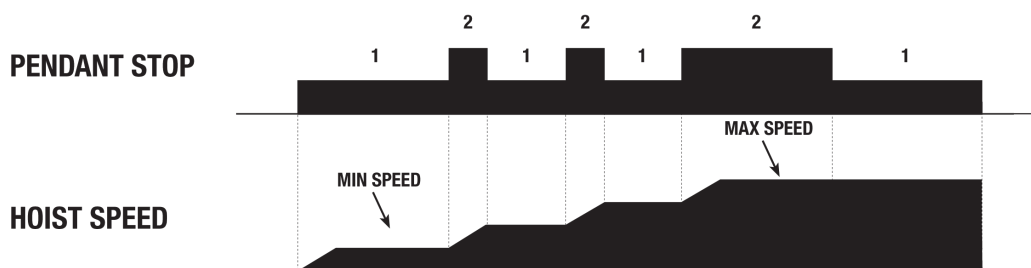

Note: Above figures shown with stopping method set for immediate stop (as in hoist applications), the frequency output is immediately set to zero and the hoist brake will immediately close when the run command is removed. With the stopping method set for ramp to stop (as in trolley applications), the trolley speed will ramp down to minimum frequency before the trolley brake (if provided) closes.

3-Step Infinitely Variable Control

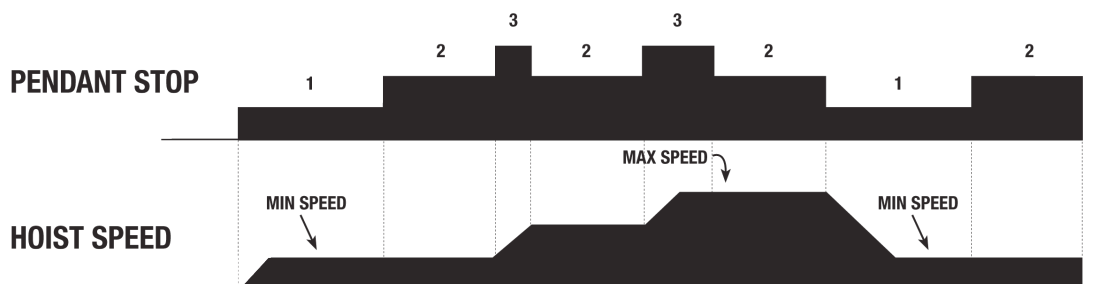

Note: Above figures shown with stopping method set for immediate stop (as in hoist applications), the frequency output is immediately set to zero and the hoist brake will immediately close when the run command is removed. With the stopping method set for ramp to stop (as in trolley applications), the trolley speed will ramp down to minimum frequency before the trolley brake (if provided) closes.

FACTORY SETTINGS OF PARAMETERS

Control	Parameter	Setting
2-Step/2-Speed and 3-Step/3-Speed	B01.01 - First Speed (Hz)	10 Hz
	B01.02 - Second Speed (Hz)	30 Hz (2 Speed: 60 Hz)
	B01.03 - Third Speed (if equipped, Hz)	60 Hz
	B05.01 - Acceleration Time (seconds)	1 second
	B05.02 - Deceleration Time (seconds)	1 second
	C03.12 - EPLS (see page 18)	1 (enabled)
	C03.22 - Slow Approach (see page 18)	1 (enabled)
	C06.01 - Swift-Lift (see page 27)	1 (enabled)
2-Step/3-Step Infinitely Variable	B01.01 - First Speed (Hz)	10 Hz
	B01.05 - Maximum Speed (Hz)	60 Hz
	B02.01 - Ref. Upper Limit (% , see below)	50
	B05.01 - Acceleration Time (seconds)	1 second
	B05.02 - Deceleration Time (seconds)	1 second
	C03.12 - EPLS (see page 18)	1 (enabled)
	C03.22 - Slow Approach (see page 18)	1 (enabled)
C06.01 - Swift-Lift (see page 27)	1 (enabled)	

NOTE:

1. Standard factory setting for control is 3 Step Infinitely Variable.
2. The parameters listed in this table can be changed in VFD "USER" menu. The other parameters have been factory set and password protected and should not be reset without authorization by Magnetek and/or CM.

CHANGING SPEEDS

Run speeds can be changed for 2-Step/2-Speed and 3-Step/3-Speed run modes by simply changing B01.01, B01.02, and B01.03 (if applicable) to the desired frequency.

For Infinitely Variable modes, B01.05 must be adjusted to the desired maximum speed. Then, B02.01 must be adjusted with the following equation: $B02.01 = ((B01.05)/(120))*100$

For example, if the desired maximum speed (B01.05) is 30 Hz, $B02.01 = \frac{B01.05}{120} * 100 = 25$.

FACTORY SETTINGS OF PARAMETERS

Fault Code	Fault or Indicator Name/Description	Corrective Action
BB (flashing) Base Block	External Base Block Indicator. The flashing base block signal is the result of a multi function input in the terminal strip. The base block indicates that the drive's IGBTs have been disabled. The motor will begin coasting when the base block input is received. If a RUN command is still present when the BB signal is removed, the output voltage will be restored to the previous operating level and operation will continue at the previously commanded frequency.	<ol style="list-style-type: none"> 1. Check constants H01.01 through H01.07 for proper programming. 2. Check terminal status. (U01.10)
BEO (flashing) Brake Ans Lost	Brake Answer back signal is lost during run. While running, the multi-function input brake answer back is lost.	<ol style="list-style-type: none"> 1. Check brake answer back circuit. 2. Check terminal status. (U01.10).
BE4 (flashing) Brake Answer 1	Brake Answer-Back, Brake Not Released. At Start, Brake Answer-back is not input within predetermined time (C08.04) after electric brake release command is output-Electric brake not released.	<ol style="list-style-type: none"> 1. Check brake answer back circuit. 2. Increase the value of C08.04. 3. Check terminal status. (U01.10).
BE5 (flashing) Brake Answer 2	Brake Answer-Back, At Stop. At Stop, Brake Answer-back signal is not removed within predetermined time (C08.11) after electric brake release command is removed-Electric brake not closed.	<ol style="list-style-type: none"> 1. Check brake answer back circuitries 2. increase the value of C08.11 time.
CALL (flashing)	Serial Communication Transmission Error. Control data is not received correctly after power supply is turned ON for 2 sec.	<ol style="list-style-type: none"> 1. Check serial device connections. 2. Ensure drive is properly programmed for serial communication.
CE Memobus Com Err	MEMOBUS/Modbus Communication Error. Serial communications data corrupted.	<ol style="list-style-type: none"> 1. Check serial connections. (R+, R-, S+ & S-). 2. Check H05.01 through H05.03 for proper programming.
CF Control Fault	Control Fault. A torque limit was reached for 3 seconds or longer while in open Loop Vector	<ol style="list-style-type: none"> 1. Perform auto tune. 2. Check motor parameters
COF	Current Offset Fault. The drive automatically adjusts the current offset, the calculated value exceeded the allowable setting range.	<ol style="list-style-type: none"> 1. Press reset. 2. Check brake. 3. Check brake contact.
CPF02	A/D Conversion Error. An A/D conversion error occurred.	<ol style="list-style-type: none"> 1. Cycle power to drive. 2. Ensure that the control board terminals and wiring are shielded from electrical noise. 3. Check resistance of potentiometer. 4. Replace the drive.
CPF03	PWM Data Error. There is a problem with the PWM data.	<ol style="list-style-type: none"> 1. Cycle power to the drive. 2. Replace the control board.
CPF06	EEPROM Data Error. There is an error in the data saved to EEPROM.	<ol style="list-style-type: none"> 1. Cycle power to the drive. 2. If the problem continues, replace the drive.
CPF07	Terminal Board Communications Error. A communication error occurred at the terminal board.	<ol style="list-style-type: none"> 1. Cycle power to the drive. 2. Check connections on the control board.
CPF08	EEPROM Serial Communications Fault. EEPROM communications are not functioning properly.	<ol style="list-style-type: none"> 1. Cycle power to the drive. 2. If the problem continues, replace the drive.
CPF11	RAM Fault.	<ol style="list-style-type: none"> 1. Cycle power to the drive. 2. Replace the drive.
CPF12	FLASH Memory Fault. Problem with the ROM (FLASH memory)	<ol style="list-style-type: none"> 1. Cycle power to the drive. 2. Replace the drive.
CPF13	Watchdog Circuit Exception. Control circuit damage.	<ol style="list-style-type: none"> 1. Cycle power to the drive. 2. Replace the drive.
CPF14	Control Circuit Fault. CPU Error (CPU operates incorrectly due to noise, etc)	<ol style="list-style-type: none"> 1. Cycle power to the drive. 2. Replace the drive.
CPF16	Clock Fault. Standard clock error.	<ol style="list-style-type: none"> 1. Cycle power to the drive. 2. Replace the drive.
CPF17	Timing Fault. A timing error occurred during an internal process.	<ol style="list-style-type: none"> 1. Cycle power to the drive. 2. Replace the drive.
CPF18 and CPF19	Control Circuit Fault. CPU error (CPU operates incorrectly due to noise, etc.)	<ol style="list-style-type: none"> 1. Cycle power to the drive. 2. Ensure that the control board terminals and wiring are shielded from electrical noise. 3. Replace the drive.
CPF20 and CPF21	RAM fault, FLASH memory error, watchdog circuit exception.	<ol style="list-style-type: none"> 1. Cycle power to the drive. 2. Replace the drive.

CPF22	A/D Conversion Fault. A/D conversion error.	<ol style="list-style-type: none"> 1. Cycle power to the drive. 2. Ensure that the control board terminals and wiring are shielded from electrical noise. 3. Replace the drive.
CPF23	PWM Feedback Fault. PWM feedback error.	<ol style="list-style-type: none"> 1. Cycle power to the drive. 2. Replace the drive.
CPF24	Drive Capacity Signal Fault. Entered a capacity that does not exist (checked when the drive is powered up.)	<ol style="list-style-type: none"> 1. Cycle power to the drive. 2. Replace the drive.
CRST	Cannot reset. External fault occurred and reset button was pressed before motor was completely stopped. Fault reset was being executed when a RUN command is executed during a fault.	<ol style="list-style-type: none"> 1. Wait for motor to come to complete stop. 2. Reset fault before issuing a RUN command.
DNE Drive not ready	User is trying to give a run command while a FWD or REV is present at Power Up.	<ol style="list-style-type: none"> 1. Check input terminals. 2. Check H01.01 to H01.07 programming.
EF (flashing) External Fault	Both FORWARD/UP and REVERSE/DOWN commands are input at same time for 500 msec or longer.	<ol style="list-style-type: none"> 1. Check control input wiring. 2. Check the sequence of operation.
EF0 Optional External Fault	External fault input from communication option card.	<ol style="list-style-type: none"> 1. Check communication option card connection and signals. 2. Check external device for any fault(s).
EF1 External Fault 1	External fault occurs on Terminal S1.	<ol style="list-style-type: none"> 1. Check constant H01.01 for proper programming. 2. Check the conditions for input terminal S1 (U01.10).
EF2 External Fault 2	External fault occurs on Terminal S2.	<ol style="list-style-type: none"> 1. Check constant H01.02 for proper programming. 2. Check the conditions for input terminal S2 (U01.10).
EF3 External Fault 3	External fault occurs on Terminal S3.	<ol style="list-style-type: none"> 1. Check constant H01.03 for proper programming. 2. Check the conditions for input terminal S3 (U01.10).
EF4 External Fault 4	External fault occurs on Terminal S4.	<ol style="list-style-type: none"> 1. Check constant H01.04 for proper programming. 2. Check the conditions for input terminal S4 (U01.10).
EF5 External Fault 5	External fault occurs on Terminal S5.	<ol style="list-style-type: none"> 1. Check constant H01.05 for proper programming. 2. Check the conditions for input terminal S5 (U01.10).
EF6 External Fault 6	External fault occurs on Terminal S6.	<ol style="list-style-type: none"> 1. Check constant H01.06 for proper programming. 2. Check the conditions for input terminal S6 (U01.10).
EF7 External Fault 7	External fault occurs on Terminal S7.	<ol style="list-style-type: none"> 1. Check constant H01.07 for proper programming. 2. Check the conditions for input terminal S7 (U01.10).
GF Ground Fault	Ground Fault. Current shorted to ground exceeded 50% of rated current in output side of the drive. Setting L08.09 to 1 enable ground fault detection in models 2025 and 4014 or larger.	<ol style="list-style-type: none"> 1. Disconnect motor from drive and check it for shorts using a megger. 2. Ensure that R/C Surge Suppressors are used across all brake contactor coils to prevent disturbance by electrical transients.
HBB	Hardware Base Block. The Safe Disable Input channel is open.	<ol style="list-style-type: none"> 1. Check if external safety circuit tripped and disabled the drive. 2. If the Safe Disable function is not utilized, check if the terminals HC and H1 are linked
LC Load Check Err	Load Check Fault. Load is greater than specified amount.	<ol style="list-style-type: none"> 1. Reduce Load. 2. Check Load Check sequence set-up. (C05.XX)
LF Output Phase Loss	An open phase occurred at the inverter output.	<ol style="list-style-type: none"> 1. Check for broken wires in output cable. 2. Check for open winding in the motor. 3. Check for loose terminals.

LL1 (flashing) Lower Limit 1 Err	Lower Limit 1-SLOW Down Indicator. Hoist has reached lower slow approach limit. No action is required. If desired, slow approach limits may be disabled as described on page 18.	<ol style="list-style-type: none"> 1. May not require corrective action. 2. Check the position of the Limit Switch.
LL2 (flashing) Lower Limit 2 Err	Lower Limit 2-STOP Indicator. Hoist has reached lower limit. Run hoist UP away from lower limit, or if limit is in an inappropriate place, reset limits as described on page 18.	<ol style="list-style-type: none"> 1. May not require corrective action. 2. Check the position of the Limit Switch.
MNT Maintenance Required	Maintenance Required Alert. Running time has exceeded C12.05	<ol style="list-style-type: none"> 1. Reset timer by MFI=5A or depress Mode/Service key three times and enter within 2 seconds.
OC Over Current	Output current exceeds 200% of inverter rated output current.	<ol style="list-style-type: none"> 1. Check for a phase-to-phase short in the motor or wiring using a megger. 2. Extend the acceleration/deceleration time. 3. Check torque limit setting.
OH (flashing) Heatsnk Over temp	Overheat Pre-Alarm. Heatsink is overheating. The temperature of the inverters heatsink exceeded the setting in L08.02.	<ol style="list-style-type: none"> 1. The inverter cooling fan has stopped. 2. Reduce the ambient temperature.
OH1 Heatsink MaxTemp	Overheat Fault. There are two situations that result in an overheat fault. The first occurs when the measured heat sink exceeded 105°C. The second is a result of a fault in the internal 24VDC cooling fan.	<ol style="list-style-type: none"> 1. Ensure that the heat sink cooling fans are functioning. 2. Ensure that the heat sink is free from dirt and debris. 3. Ensure that the inverter's ambient temperature is within specifications. 4. Replace the 24VDC fan. 5. Replace the heat sink thermistor(s).
OH2 (Flashing) Overheat 2	Overheat Alarm. Signal is input by external terminal. H01.XX=39	
OH3 Motor Overheat 1	Motor Overheating 1. Thermistor analog input detected motor overheating. See L01.03.	<ol style="list-style-type: none"> 1. Check the motor rated current value, E02.01. 2. Increase cycle time OH4 Motor or reduce the load.
OH4 Motor Overheat 2	Motor Overheating 2. Thermistor analog input detected motor overheating. See L01.04.	
OL1 Motor Overloaded	Motor Overload Fault. Inverter output exceeded the inverter overload level.	<ol style="list-style-type: none"> 1. Ensure drive is programmed with proper motor full load Amps (E02.01). 2. Reduce the load.
OL2 INV Overload	Inverter Overload Fault. Inverter output exceeded the inverter overload level.	<ol style="list-style-type: none"> 1. Reduce the load. 2. Extend the acceleration time.
OPE01 kVA Selection	kVA Settings Fault. Inverter kVA setting range is incorrect.	<ol style="list-style-type: none"> 1. Check 002.04 constant for proper kVA.
OPE02	Parameter Range Setting Error. Parameter settings are set outside the parameter range.	<ol style="list-style-type: none"> 1. Press enter to view parameter. 2. Change parameter to appropriate setting.
OPE03 Terminal	Multi-Function Input Settings Fault. Set values other than "F" and "FF" are duplicated.	<ol style="list-style-type: none"> 1. Check the settings for H01.01 to H01.07, verify that the same input is not used twice.
OPE04 Terminal	Parameters do not match. The drive, control board, or terminal board has been replaced, and the parameter settings between the controller board or terminal board do not match.	<ol style="list-style-type: none"> 1. Press ENTER to view the parameter. 2. Change parameter(s) to appropriate settings. 3. Set A01.05 = 5550.
OPE07 Analog Selection	Multi-Function Analog Input Setting Fault. Set values other than 00 and 0F are duplicated.	<ol style="list-style-type: none"> 1. Check setting for H03.02 and H03.10. Verify that the same value is not used twice.
OPE08 Terminal	Selection Parameter error. A parameter has been changed that is not available in the present control method.	<ol style="list-style-type: none"> 1. Undo the last parameter change (if known). 2. Scroll through modified constants for obvious setting error. 3. Perform a user initialize (A01.05=1110) CAUTION: All settings will be restored to the factory defaults.
OPE10 V/fPtm Setting	V/f Parameter Setting Error.	<ol style="list-style-type: none"> 1. Check Parameters E01.04 to E01.11.
OPE23 Load Check	Check C05.04≤C05.07≤C05.09.	<ol style="list-style-type: none"> 1. Load Check setting error.
OT1 Overtorque Det 1	Overtorque Detection Level 1 Fault. Current is higher than set value (L06.02) for more than set time (L06.03).	<ol style="list-style-type: none"> 1. Check for proper programming of L06.02 and L06.03.

OT2 Overtorque Det 2	Overtorque Detection Level 2 Fault. Defined by L06.05. Alarm defined by L06.04.	1. Check for proper programming for L06.XX constant.
OV DC Bus Overvolt	Overvoltage Fault. The DC bus voltage exceeded for overvoltage level. Detection level: 230V class-approximate 410V 460V class-approximate 820V	1. Extend the deceleration time. 2. Check for proper DBU operation. 3. Check the resistor. 4. Check the line voltage. 5. If on a load break hoist, check the gear box.
OV (flashing) DC Bus Overvolt	Overvoltage Fault. Overvoltage occurs during stop. Main circuit DC voltage rises above the detection level while the drive output is off. Detection level: 410V or more for 230V, 820V or more for 460V.	1. Check the line voltage.
PF Input Pha Loss	Input Phase Loss Fault. Inverter input power supply has open phase.	1. Check the line voltage. 2. Remove power. 3. Retighten the input terminal screws. 4. Check the fuses.
RR DynBrk Transistr	Braking Transistor Fault. Internal Braking transistor failed.	1. Verify that the external braking resistor is connected to the proper terminals. 2. Confirm that the proper resistor is installed. 3. Check for a short circuit across the braking resistor.
UL1 Upper Limt 1 Err	Upper Limit 1-SLOW DOWN Indicator. Hoist has reached upper slow approach limit. No action is required. Slow approach limits can be disabled by following the instructions on page 18.	1. May not require corrective action. 2. Check the position of the Limit Switch.
UL2 Upper Limt 2 Err	Upper Limit 2-Stop Indicator. Hoist has reached upper limit. Run hoist DOWN away from upper limit. If limit is set in an inappropriate place, follow the instructions to reset limits on page 18.	1. May not require corrective action. 2. Check the position of the Limit Switch.
UL3 Upper Limt 3 Err	Upper Limit 3-Weighted Stop. Upper Limit weighted limit switch tripped	1. May not require corrective action. 2. Check the position of the Limit Switch. 3. Check the condition of the Limit Switch. 4. Check the conditions of/for input terminal H01.XX (U01.10)
UT1 Undertorque Det1	Undertorque Detection 1. The current is less than L06.02 for more that L06.03.	1. Check settings. 2. Check motor coupling.
UT2 Undertorque Det2	Undertorque Detection 2. The current is less than L06.05 for more that L06.06.	1. Check settings. 2. Check motor coupling.
UV (Flashing) DC Bus Undervolt	Undervoltage Fault. Undervoltage status occurs for more than 2 sec during STOP. Input voltage drops below 190V DC or less for 230V AC class, 380V DC or less for 460V AC class.	1. Check the power source wiring. 2. Replace and bad branch fuses. 3. Check collector system.
UV1 DC Bus Undervolt	Undervoltage 1 Fault. Undervoltage status occurs for more than 2 sec during RUN command. Input voltage drops below 190V DC or less for 230V AC class, 380V DC or less for 460V AC class.	1. Check the power source wiring. 2. Correct the line voltage. 3. Check collector system.
UV2 CTL PS Undervolt	Undervoltage 2 Fault. The inverter detected a loss of 24V logic power supply voltage.	1. Check the power source wiring. 2. Correct the line voltage. 3. Check collector system.
UV3 MC Answerback	MC Fault. The pre-charge contactor opened during operation	1. Check the power supply wiring. 2. Correct the line voltage. 3. Check collector system. 4. Wait 30-45 seconds before restarting drive after auto shut down.

TABLE 12. TROUBLESHOOTING

TROUBLE	PROBABLE CASE	REMEDY
1. Hook does not respond to the control station or control device	A.) No voltage at hoist-main line or branch circuit switch open; branch line fuse blown or circuit breaker tripped.	A.) Close switch, replace fuse or reset breaker.
	B.) Phase failure (single phasing, three phase unit only)-open circuit, grounded or faulty connection in one line of supply system, hoist wiring, reversing contactor, motor leads or windings.	B.) Check for electrical continuity and repair or replace defective part.
	C.) The upper or lower limits have stopped the hoist motion.	C.) Press the “other” control and the hook should respond. Adjust limit switches as described on page 18.
	D.) Wrong voltage or frequency.	D.) Use the voltage and frequency indicated on hoist identification plate.
	E.) Low Voltage.	E.) Correct low voltage condition as described on page 11.
	F.) Brake not releasing-open or shorted coil winding; armature binding.	F.) Check electrical continuity and connections. Check that correct coil has been installed. Check brake adjustment as described on page 17.
	G.) Excessive load.	G.) Reduce loading to the capacity limit of hoist as indicated on the identification plate.
	H.) Signal connections have unplugged from Brake Board.	H.) Firmly press the 6 and 13 pin connection plugs into board. Limits have to be cleared and reset if hoist moved without encoder input. Verify safe limit operation before proceeding.
2.) Hook moves in wrong direction.	A.) Wiring connections reversed at the control station.	A.) Check connections with the wiring diagram.
	B.) Reversal of motor leads.	B.) Refer to installation instructions on page 8.
3.) Hook lowers but will not raise.	A.) Excessive load.	A.) See item 1H.
	B.) Open hoisting circuit-open; control station contacts not making; upper limit position has been reached.	B.) Check electrical continuity and repair or replace defective part. Check operation of limit switch as described on page 12.
	C.) Phase failure.	C.) See item 1B.
4.) Hook raises but will not lower.	A.) Open hoisting circuit-open; control station contacts not making; upper limit position has been reached.	A.) Check electrical continuity and repair or replace defective part. Check operation of limit switch as described on page 12.
5.) Hook lowers when hoisting control is operated.	A.) Phase failure.	A.) See item 1B.
	B.) Phase reversal.	B.) Refer to installation instruction on page 11.

TABLE 12. TROUBLESHOOTING

TROUBLE	PROBABLE CASE	REMEDY
6.) Hook does not stop promptly.	A.) Brake slipping.	A.) Check brake adjustment as described on page 17.
	B.) Excessive load.	B.) See item 1H.
7.) Hoist operates sluggishly.	A.) Excessive load.	A.) See item 1H.
	B.) Low voltage.	B.) Correct low voltage condition as described on page 11.
	C.) Phase failure or unbalanced current in the phases.	C.) See item 1B.
	D.) Brake dragging.	D.) Check brake adjustment as described on page 17.
8.) Motor overheats.	A.) Low voltage.	A.) Correct low voltage condition as described on page 11.
	B.) Excessive load.	B.) See item 1H.
	C.) Extreme external heating.	C.) Above an ambient temperature of 40°C. (104°F), the frequency of hoist operation must be limited to avoid overheating of motor. Special provisions should be made to ventilate the space or shield the hoist from radiation.
	D.) Frequent starting or reversing.	D.) Avoid excessive inching, jogging or plugging. This type of operation drastically shortens the motor and contactor life and causes excessive brake wear.
	E.) Phase failure or unbalanced current in the phase.	E.) See item 1B.
	F.) Brake dragging.	F.) Check brake adjustment as described on page 17.
9.) Hook fails to stop at either or both ends of travel.	A.) Limit switches not set correctly.	A.) Set the hook limits per the procedure on page 18.
	B.) Missing, loose, or damaged components.	B.) Check for missing, loose and/or damaged encoder boards, harnesses, magnetic pinion.
10.) Hook stopping point varies.	A.) Missing, loose, or damaged components.	A.) Check for missing, loose and/or damaged encoder boards, harnesses, magnetic pinion.
	B.) Brake not holding.	B.) Check the brake adjustment as described on page 17.

ELECTRICAL DATA

TO DETECT OPEN AND SHORT CIRCUITS IN ELECTRICAL COMPONENTS

Open circuits in the coils of electrical components may be detected by isolating the coil and checking for continuity with an ohmmeter or with the unit in series with a light or bell circuit.

Shorted turns are indicated by a current draw substantially above normal (connect ammeter in series with suspected element and impose normal voltage) or D.C. resistance substantially below normal. The current method is recommend for coils with very low D.C. resistance.

Motor current draw in the stator should be measured with the rotor in place and running. Brake coil current should be measured with the core iron in operating position.

Table 13. Electrical Data for Hoist Components

Models	D.C. Brake Coil Voltage	Nominal Current (Amps)	*D.C. Resistance (Ohms)
A, AA, B, C, E, F & H	205	.0975	2101

Models	Volts-Phase-Hertz	H.P. (kW)	Motor Full Load Current (Amps)	Leads	*D.C. Resistance (Ohms)
A, AA, B, C, E, F, H	230-3-60	1/2 (.37)	1.8	3 - 6	7.8
	380-3-50		1.0	2 - 5	7.8
	460-3-60		0.9	1 - 4	7.8
				8 - 9	15.6
				8 - 7	15.6
				9 - 7	15.6

*Resistance values listed are nominal and they may vary slightly from component to component.

REFERENCE WIRING DIAGRAMS

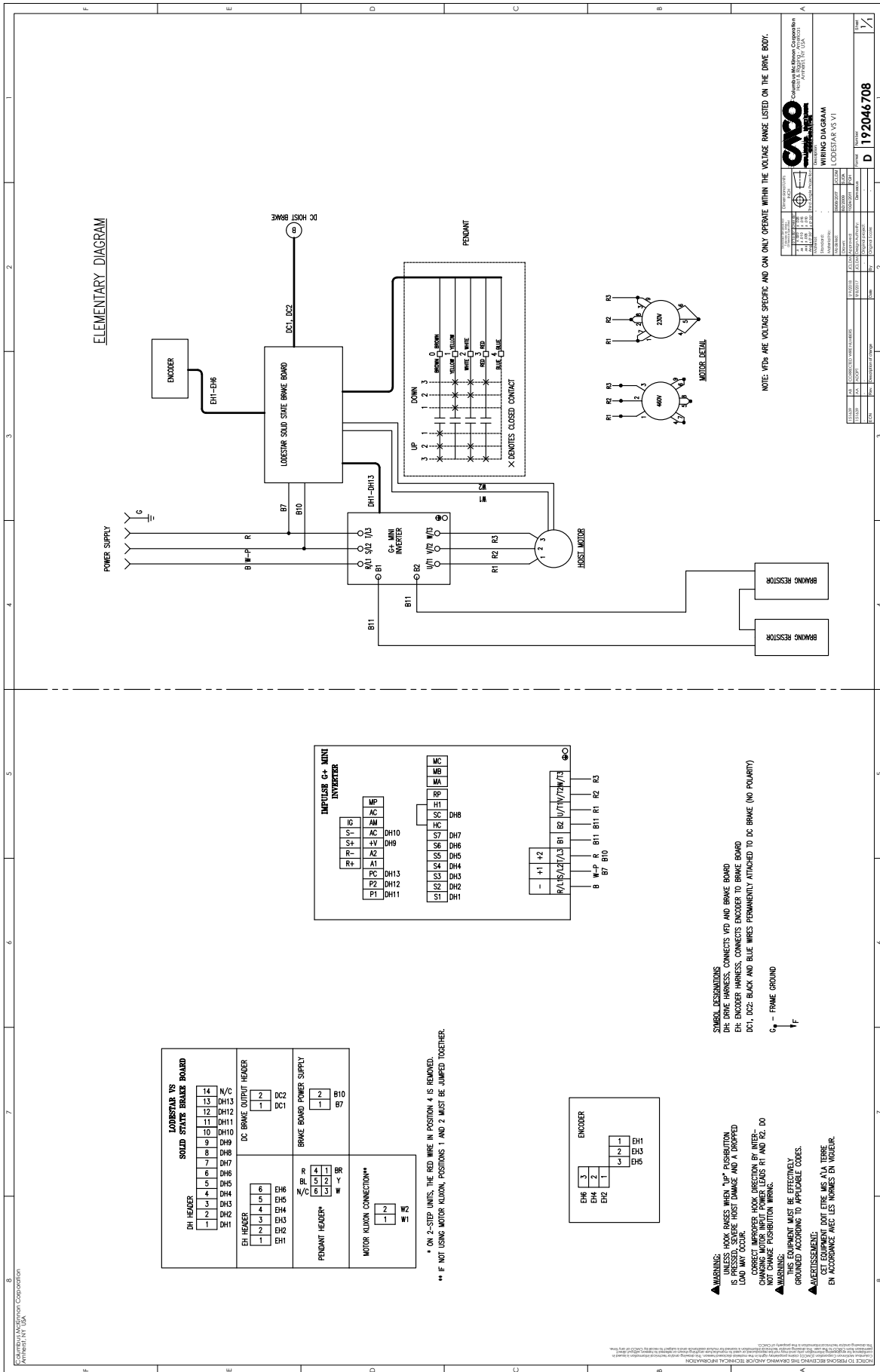

ASSEMBLY INSTRUCTIONS

SWIVEL HOOK OR LUG SUSPENSION

Models E & H. Assemble the dead end bolt and block through the suspension adapter as shown in Figure 13.

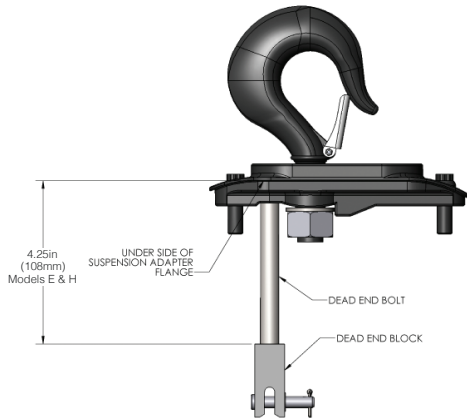

Figure 13. Hook Suspension

FASTENERS

See tables 2a and 2b for recommended torque values.

⚠ WARNING

Using other than CM supplied high strength suspension screws to attach the suspension adapter to the hoist may cause the screws to break and allow the hoist and load to fall.

TO AVOID INJURY:

Use only the CM supplied suspension screws to attach the suspension to the hoist and hand torque these screws to the recommended seating torque as specified in tables 2a and 2b. DO NOT apply any type of lubricant to the threads of these screws. Lubricating the threads will reduce the effort to seat the screws and as a result, tightening the screws to the above recommended torque may break the screw, damage the suspension adapter, strip the nuts and/or damage the hoist frame.

SUSPENSION BOLT SHOULD BE REPLACED ANY TIME THE SUSPENSION IS REMOVED FROM THE HOIST

LOWER HOOK BLOCK PIN

When removing or installing the lower hook pin, care must be taken so as to prevent damaging the pin and/or hook block. These pins are tapered groove pins and as a result, they can only be removed in one direction. To remove the pin, a V-Block, drift and hammer (or slow acting press) are required. The drift should be the same diameter as the pin (5/16" diameter (7.94mm) for Models A, AA, B, C, E, F, & H and it should be placed on the small end of the pin. The small end of the pin is the end opposite the end on which the 3 grooves are visible. Place the hook block in the V-Block and drive the pin out using the drift and a hammer or slow acting press.

To re-install the pin, the parts must be arranged the same as they were when the pin was removed. To do this, use the small end of the pin as a gage. First check the holes in the hook block body and determine which hole is the largest. Place the hook body in the V-Block with the larger hole on top. Next, check each end of the hole in the lower hook chain block and determine which end is the largest. Place the chain in the slot of the chain block and insert the chain block, with the large hole on top, into the hook block body. Align the holes in the hook block body with the hole in the chain block and insert the small end of the pin in the hole. Push the pin in

by hand until it stops and then use a hammer or slow acting press to drive the pin into position so that the end of the pin is flush with the outside surface of the hook block body.

⚠ WARNING

Use of improper lower hook chain block pin as well as improper installation of this pin can cause the pin to break and allow the load to fall.

TO AVOID INJURY:

Use only CM supplied, special high strength lower hook chain block pin to attach the chain to the lower hook block and install the pin as directed above.

REMOVAL AND INSTALLATION OF LOAD CHAIN

⚠ WARNING

Improper installation (reeving) of the load chain can result in a dropped load.

TO AVOID INJURY/DAMAGE:

- Verify use of proper size and type of hoist load chain for specific hoist.
- Install load chain properly as indicated below.

NOTE: When installing load chain in Models E & H by either of the "starter chain" methods, two loose end connecting links (627-743) must be used. Hoist load chain can be installed by any one of several methods.

⚠ WARNING

USE OF COMMERCIAL OR OTHER MANUFACTURER'S CHAIN AND PARTS TO REPAIR CM HOISTS MAY CAUSE LOAD LOSS.

TO AVOID INJURY:

Use only CM supplied replacement load chain and parts. Chain and parts may look alike, but CM chain and parts are made of specific material or processed to achieve specific properties.

The first method is recommended when replacing severely worn load chain and requires disassembling the hoist. Method 2 does not require hoist disassembly, where as Method 3 requires only partial disassembly.

Method #1

- Disconnect hoist from power supply.
- Disable the electronic limits. Refer to the limit switch section.
- Detach loose end of load chain from hoist frame, see Figure 7. Also, on single reeved models, detach the lower hook block from the load chain. On double reeved models E & H unfasten the dead end side of load chain.
- Continue to disassemble the hoist and inspect the liftwheel, chain guides, motor housing and gear housing which if worn or damaged may cause premature failure of the new chain. Parts can be easily identified by referring to pages Parts List section of table of contents.
- If the liftwheel pockets, in particular the ends, are worn or scored, replace liftwheel. If chain guides and housing are worn, cracked or damaged these parts should also be replaced.
- Reassemble hoist with the new load chain inserted over the liftwheel. Position chain with the weld on up standing links away from liftwheel and leave only one foot of chain

hanging free on loose end side. Make sure the last chain link is an upstanding link. On double reeved models, make sure that the new load chain has an even number of links. On triple reeved models, make sure that the new chain has an odd number of links. This will prevent twist in chain. To simplify handling when reassembling the hoist, a short undamaged piece of the old chain may be used as a “starter chain”. Position this piece of chain in exactly the same manner as explained above for the “new chain”, and complete the reassembly of the hoist.

- g. Attach the loose end link to chain and connect it to the hoist frame with the loose end screw, washer and lock washer, see Figure 7.
- h. Set the upper and lower limits before putting the hoist into service. Refer to the limit switch section.

BE CERTAIN THERE IS NO TWIST.

CAUTION: For double reeved models, be sure to disconnect one of the loose end links from the load chain before attaching it to the hoist.

- i. For single reeved models, attach the hook block to load chain and proceed to step K.
- j. For double reeved models, run the hoist (UP) until only 3 feet (.9 m) in chain remains on dead end side. This will minimize the chance of introducing a twist between hook block and hoist. Allow the chain to hang free to remove twists. Using a wire as a starter, insert the chain, flat link first, into lower hook block (upstanding links will have weld toward sheave) and pull through. Insert last link into slot in dead end block making sure that no twist exists in the reeving at any point. Assemble dead end pin, washer and cotter pin as shown in Figure 7.
- k. Using a wire as a starter, insert the chain, flat link first, into lower hook block (upstanding links will have weld toward sheave) and pull through. Insert last link into slot in dead end block making certain that no twist exists in the reeving at any point. Assemble dead end pin, washer and cotter pin as shown in Figure 7.
- l. Set limit switches as described on page 18. If the new chain is longer than the old, check to be sure limit switch will allow for new length of lift. In the event maximum adjustment does not allow entire length of lift, check with CM® for modification if necessary.

 WARNING

Do not allow hook block to hit hoist or allow load chain to become taut between loose end screw and frame or else serious damage will result. If hook block should inadvertently hit the hoist—the hoist frames, load chain and hook block should be inspected for damage before further use.

Method #2

Treat the old load chain in hoist as a “starter chain” and proceed with steps from Method #1, a, b, c and h thru k. If a starter chain is used, the loose end link (two links required for double reeved models) can serve as a temporary coupling link to connect together the starter chain in the hoist and the new load chain to be installed. Then, under power, reeve the new load chain through the liftwheel area, replacing the starter chain in unit. Run enough chain through to attach loose end link to hoist frame.

Method #3

- a. First proceed with Steps 1a, b & c from Method #1.
- b. Then, carefully run the load chain out of the hoist.
- c. Disconnect hoist from power supply.
- d. Remove the electric brake assembly.
- e. Rotate the brake hub by hand, at the same time feeding the load chain into and through liftwheel area with hoist upside down or using a wire to pull the load chain up onto the liftwheel as explained in Method #1 step 1f.
- f. Refer to Method #1 steps g thru j above to complete the installation.

CUTTING CHAIN

CM® Load chain is hardened and it is difficult to cut. The following methods are recommended when cutting a length of new chain from stock or cutting off worn chain.

1. Use a grinder and nick the link on both sides (Figure 14), then secure the link in a vise and break off with a hammer.
2. Use a 177.8 mm (7 inches) minimum diameter by 3.175 mm (1/8 inch) thick abrasive wheel (or type recommended by wheel supplier) that will clear adjacent links.
3. Use a bolt cutter (Figure 15) similar to the H.K. Porter No. 0590MTC with special cutter jaws for cutting hardened chain (25.4mm-1 inch) long cutting edge.

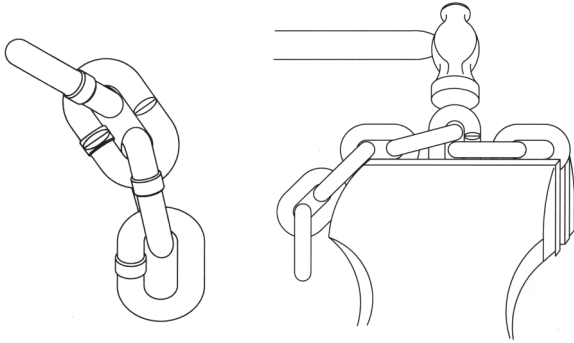

Figure 14. Cutting Chain by Nicking

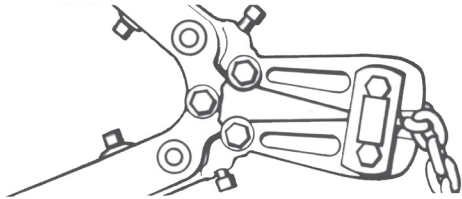

Figure 15. Cutting Chain with a Bolt Cutter

WARNING

Cutting Chain Can Produce Flying Particles.

TO AVOID INJURY:

- Wear Eye Protection.
- Provide A shield Over Chain to Prevent Flying Particles.

WARNING

Using “Commercial” or other manufacturer’s parts to repair the CM Lodestar Hoists may cause load loss.

TO AVOID INJURY:

Use only CM supplied replacement parts. Parts may look alike but CM parts are made of specific materials or processed to achieve specific properties.

WARNING

Testing

Before using, all altered, repaired or used hoists that have not been operated for the previous 12 months shall be tested by the user for proper operation. First test the unit without a load and then with a light load of 22.7 kg. (50 pounds) times the number of load supporting parts of load chain to be sure that the hoist operates properly and that the brake holds the load when the control is released. Next test with a load of *125% of rated capacity. In addition, hoists in which load sustaining parts have been replaced should be tested with *125% of rated capacity by or under the direction of an appointed person and written report prepared for record purposes. After this test, check that the Load-limiter functions.

***If Load-limiter prevents lifting of a load of 125% of rated capacity, reduce load to rated capacity and continue test.**

NOTE: For additional information on inspection and testing, refer to Code B30.16 “Overhead Hoists” obtainable from ASME Order Department, 22 Law Drive, Box 2300, Fairfield, NJ 07007-2300, U.S.A.

ORDERING INSTRUCTIONS

The following information must accompany all correspondence orders for replacement parts:

1. Hoist Model Number from identification plate.
2. Serial number of the hoist stamped below identification plate.
3. Voltage, phase, Hertz from the identification plate.
4. Length of lift.
5. Part number of part from parts list.
6. Number of parts required.
7. Part name from parts list. If trolley replacement parts are ordered, also include the type and capacity of trolley.

NOTE: When ordering replacement parts, it is recommended that consideration be given to the need for also ordering such items as gaskets, fasteners, insulators, etc. These items may be damaged or lost during disassembly or just unfit for future use because of deterioration from age or service

CHAIN STOP INSTALLATION

Place polyurethane stop block over loose end of chain and slide past desired spot that the chain stop is to be located. Place one half of chain stop on chain. Then place other half on top of the first half of chain stop. (Note: be sure that the half circle cut out side of one stop block half is aligned with hex cut out side.) Place one (1) nut into hex cutout insert one (1) screw with one (1) lock washer through hole opposite nut and loosely tighten. Repeat for second connection. Tighten both screw connections to ensure that they do not come loose.

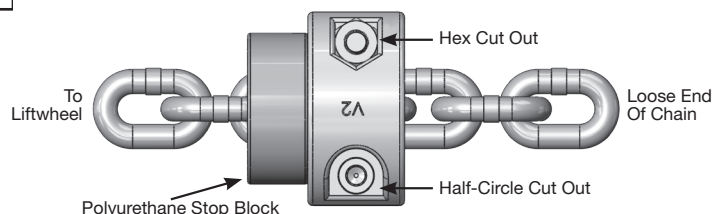
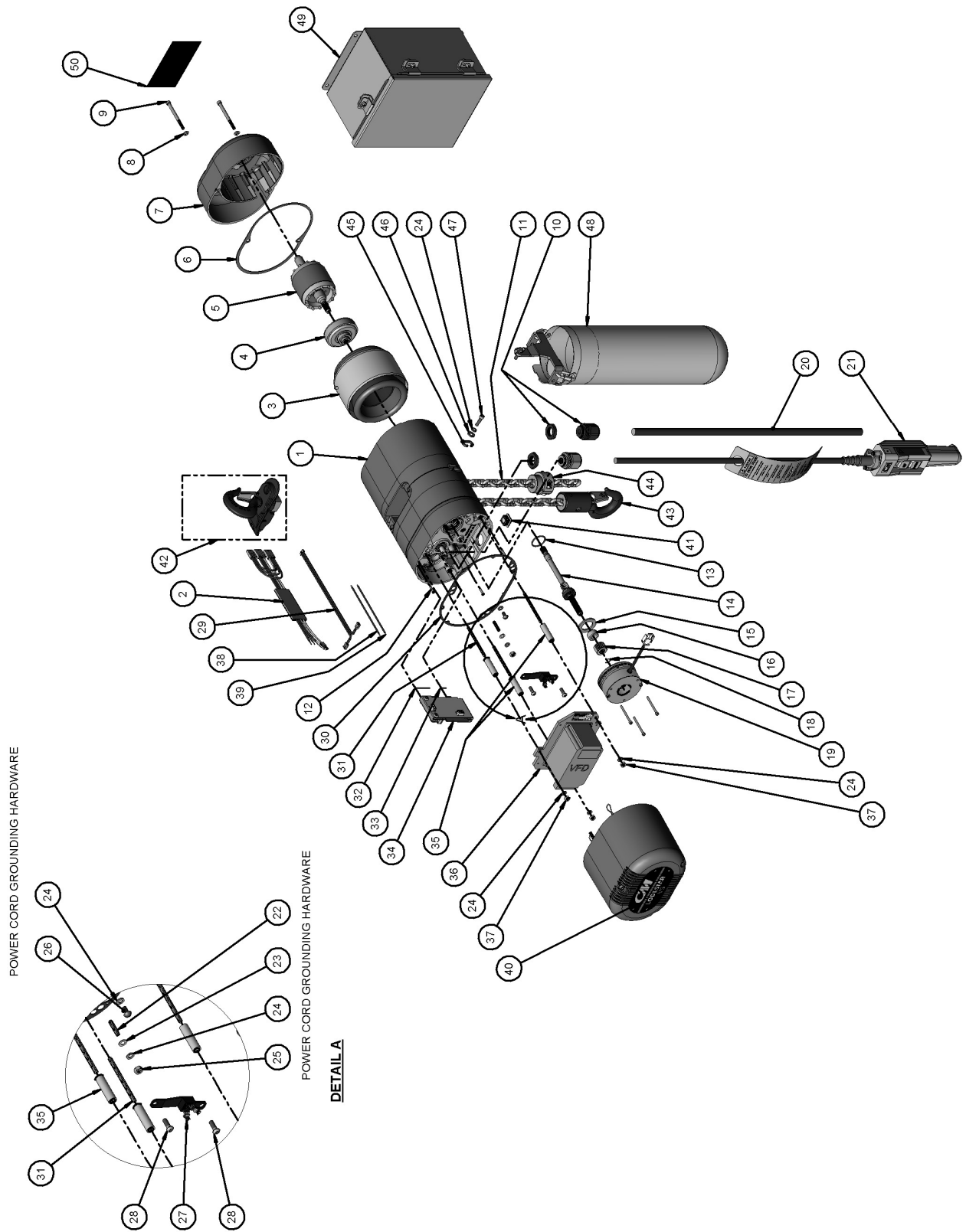

Figure 16. Chain Stop Installation

MODELS A, AA, B, C, E, F & H



MODELS A, AA, B, C, E, F & H

Item No.	Description	Model A	Model AA	Model B	Model C	Model E	Model F	Model H	Qty
1	GBOX-NH-MDL A/C-ORANGE	192045986	-	-	192045986	-	-	-	1
	GBOX-NH-MDL AA-ORANGE	-	192045990	-	-	-	-	-	
	GBOX-NH-MDL B/E/F/H-ORANGE	-	-	192045994	-	192045994	192045994	192045994	
2	WIRING HARNESS-230V UNITS	192045978							1
	WIRING HARNESS-460V & 575V UNITS	192045977							
3	STATOR	00000461							1
4	CLUTCH ASSEMBLY	C00000240	-	C00000240	-	C00000240	-	-	1
	CLUTCH ASSEMBLY	-	C00000241	-	C00000241	-	C00000241	C00000241	
5	ROTOR/SHAFT ASSY - 1/2 HP, 3Ø	00000260							1
6	MOTOR HOUSING COVER GASKET	27847							1
7	MOTOR HOUSING COVER	27058							1
8	MOTOR HOUSING COVER WASHER	982251							2
9	MOTOR HOUSING COVER SCREW	10001652							2
10	CORD GRIP 3/4" NPT	10001840							2
11	LOAD CHAIN For Models A, AA, B, C, F: Chain length = lift +1.25' For models E & H: Chain length = 2x lift + 2'	85944 (ZINC PLATED)							AS REQ'D
		85889 (BURNISHED AND OILED)							
		85965 (ZINC PHOSPHATE PLATED)							
		85915 (NICKEL PLATED)							
12	SPRING PIN	10001709							1
13	O-RING	10001355							1
14	DRIVE SHAFT ASS'Y V1 -NH-DC-10T	10001348							1
15	SPACER	10001309							1
16	HUB SPACER V1 DC BRAKE	00001432							1
17	HUB, BRAKE	192042811							1
18	ROTOR CLIP RETAINING RING	10409710							1
19	BRAKE, 205VDC	192042664							1
20	POWER CORD, LS VS 16'	23659116							1
21	CORD & PENDANT ASSY	SEE CONTROL STATION SECTION							1
22	SET SCREW	987400							1
23	WASHER	927835							1
24	LOCKWASHER	982226							6
25	GROUND NUT	987401							1
26	GROUND SCREW	987827							1
27	LSVS V1 EPLS ENCODER	192046377							1
28	ENCODER MOUNTING SCREW	983656							2
29	HARNESS, EPLS, LODESTAR VS	192044241							1
30	GASKET - V1 BACKFRAME COVER	10001344							1

MODELS A, AA, B, C, E, F & H (CONT.)

Item No.	Description	Model A	Model AA	Model B	Model C	Model E	Model F	Model H	Qty
31	ROD, 1/4-20 X 3.50 THREADED				192045461				3
32	ROD, FOAM RUBBER, Ø.125 X 1.57				192045457				1
33	ROD, FOAM RUBBER, Ø.125 X .62				192045455				1
34	SOLID STATE BRAKE RELAY-230V UNITS				192046018				1
	SOLID STATE BRAKE RELAY-460V & 575V UNITS				192046019				
35	STANDOFF				192045453				3
36	VFD-PLATE S/A-230V				192045999				1
	VFD-PLATE S/A-460V & 575V UNITS				192046000				
37	NUT				982514				3
38	JUMPER (B10)				192050183				1
39	JUMPER (B7)				192050182				1
40	BRAKE COVER-V1 S/A - ORANGE				192046013				1
41	DEAD END BLOCK HOLE PLUG	27223	27223	27223	27223	-	27223	-	1
41.1	UPPER SUSPENSION, SINGLE REEVED	2788NH	2788NH	2788NH	2788NH	-	2788NH	-	1
	UPPER SUSPENSION, DOUBLE REEVED		-	-	-	2789NH	-	2789NH	
42	UPPER SUSPENSION SCREW				987554				2
43	LOWER HOOK, SINGLE REEVED	302	302	302	302	-	302	-	-
	LOWER HOOK, DOUBLE REEVED		-	-	-	00000272B	-	00000272B	
44	CHAIN STOP KIT				24015K				1
45	LOOSE END LINK				27351				1
46	WASHER				954802				1
47	SCREW				10001696				1
48	CHAIN BAG KIT				SEE CHAIN CONTAINER SECTION				1
49	TRANSFORMER KIT-575V UNITS ONLY				11866310				1
50	CAPACITY LABEL-1/8T	00000581	00000581	-	-	-	-	-	1
	CAPACITY LABEL-1/4T	-	-	00000772	00000772	-	-	-	
	CAPACITY LABEL-1/2T	-	-	-	-	00000773	00000773	-	
	CAPACITY LABEL-1T	-	-	-	-	-	-	00000778	

MODELS A, AA, B, C, E, F & H

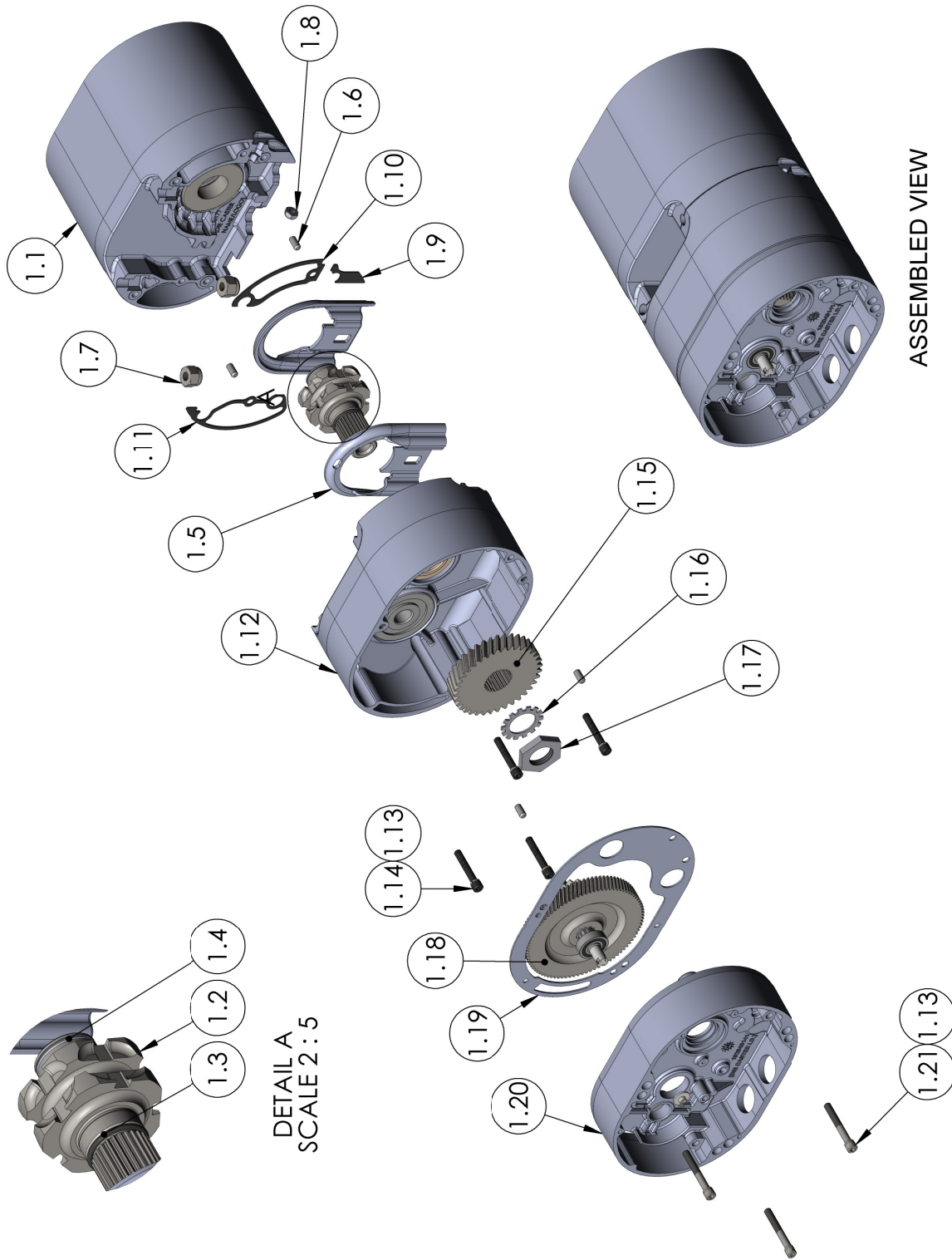

MODELS A, AA, B, C, E, F & H

Item No.	Part No.	Description	Models A & C	Model AA	Models B, E, F & H
1	192045986	COMPLETE GEARBOX ASS'Y	1	-	-
	192045990		-	1	-
	192045994		-	-	1
1.1	00000504C	V1 MOTOR HSG S/A-ORANGE	1	1	1
1.2	10001591	LIFTWHEEL S/A - V1	1	1	1
1.3	10001354	O-RING BUNA-N AS568A-122	1	1	1
1.4	10001388	O-RING BUNA-N 1.5MM X 27MM ID	1	1	1
1.5	10001110	V1 CHAIN GUIDE COATED	2	2	2
1.6	82354	1/4 DOWEL PIN	4	4	4
1.7	927755	ELASTIC STOP NUT	2	2	2
1.8	82638	NUT-1/4-20 UNC-2B HEX-UNITORQ	1	1	1
1.9	00000191	GASKET-MOTOR HOUSING-V1	1	1	1
1.10	00000190	GASKET-MOTOR HOUSING-V1	1	1	1
1.11	00000189	GASKET-MTR HSG-WIREWAY-V1	1	1	1
1.12	00000502C	V1 GEAR HSG S/A-ORANGE	-	-	1
	00000503C		1	1	-
1.13	940802	LOCKWASHER 1/4 X .078 THICK	7	7	7
1.14	28830	SCREW 1/4-20 UNC-2A X 1 5/8	4	4	4
1.15	00000159	LIFTWHEEL GEAR-36 TEETH	-	1	-
	00000160	LIFTWHEEL GEAR-45 TEETH	1	-	-
	00000161	LIFTWHEEL GEAR-59 TEETH	-	-	1
1.16	00000199	WASHER-LOCK-EXTERNAL TOOTH-1"	1	1	1
1.17	00000198	NUT-1"-12-THIN	1	1	1
1.18	192046001	INT SHAFT S/A 88T/8T	-	-	1
	192046003	INT SHAFT S/A 88T/12T	1	-	-
	192046005	INT SHAFT S/A 88T/18T	-	1	-
1.19	10001346	GASKET - V1 GEARBOX	1	1	1
1.20	192046009	BACK FRAME-V1 S/A - ORANGE	1	1	1
1.21	982699	SCREW 1/4-20 UNC-2A X 2"	3	3	3

UPPER SUSPENSIONS

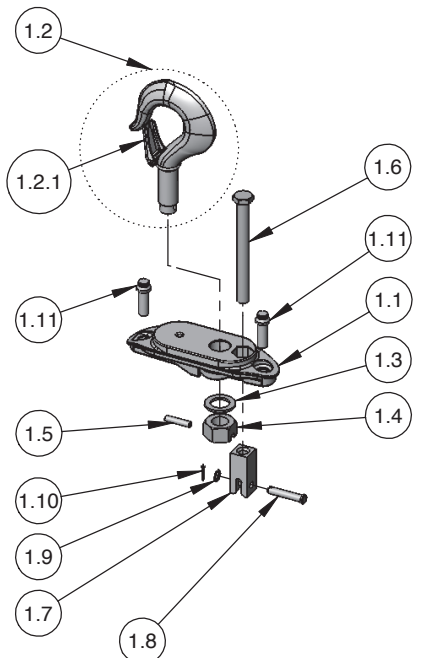

SWIVEL HOOK ASSEMBLY

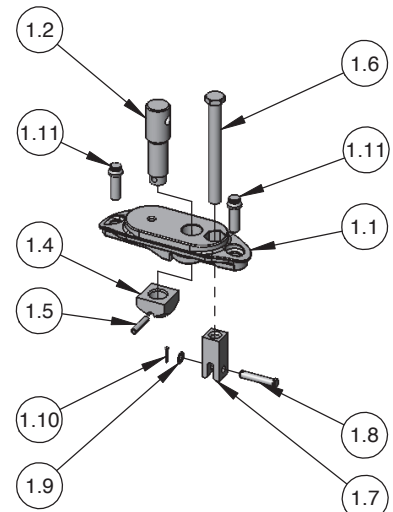

LUG ASSEMBLY

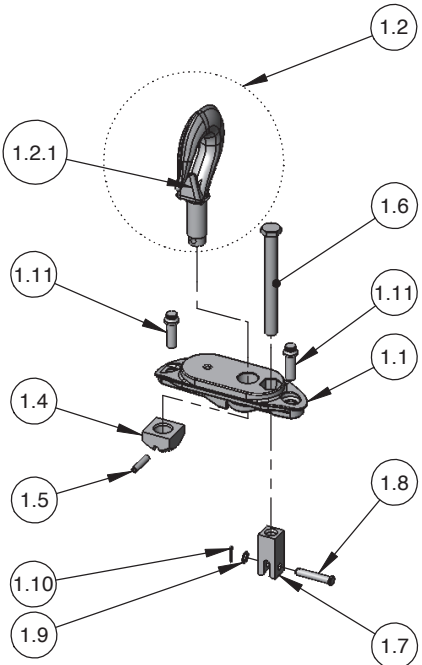

RIGID HOOK ASSEMBLY

UPPER SUSPENSIONS

UPPER SUSPENSIONS

Item No.	Description	Part Numbers		Qty.
		Models A, AA, B, C & F	Models E & H	
1	SWIVEL SUSPENSION ASSEMBLY - W/ LATCH TYPE HOOK	2792NH	2793NH	1
	SWIVEL SUSPENSION ASSEMBLY - W/ LATCHLOK TYPE HOOK	2796NH	-*	
	RIGID SUSPENSION ASSEMBLY - W/ LATCH TYPE HOOK	2788NH	2789NH	
	RIGID SUSPENSION ASSEMBLY - W/ LATCHLOK TYPE HOOK	2790NH	-*	
	LUG SUSPENSION FOR MOTOR DRIVEN TROLLEY	2992NH	2993NH	
	LUG SUSPENSION FOR LOW HEADROOM TROLLEY	2778NH	2779NH	
1.1	SUSPENSION ADAPTER	00000218B	00000223B	1
1.2	UPPER HOOK SUB-ASSEMBLY - LATCH TYPE	28689B	28697B	1
	UPPER HOOK SUB-ASSEMBLY - LATCHLOK TYPE	28643	-*	
	SUSPENSION LUG FOR MOTOR DRIVEN TROLLEY	27454	27455	
	SUSPENSION LUG FOR LOW HEADROOM TROLLEY	27450	27452	
1.2.1	LATCH KIT	45661	45661	-**
1.3	THRUST WASHER (FOR SWIVEL SUSPENSIONS ONLY)	27786	45930	1
1.4	UPPER HOOK COLLAR FOR SWIVEL SUSPENSIONS	27350	45385	1
	UPPER HOOK COLLAR FOR RIGID HOOK AND LUG SUSPENSIONS	27372	27373	
1.5	SPRING PIN	27805	45941	1
1.6	DEAD END BOLT	-	89508	1
1.7	DEAD END BLOCK	-	27397	1
1.8	DEAD END PIN	-	82320	1
1.9	WASHER	-	987878	1
1.10	COTTER PIN	-	988330	1
1.11	SUSPENSION SCREW	987554	987554	2

*Contact factory for Latchlok hooks and assemblies

** Latch Type hooks assemblies come with latches installed

**UPPER SUSPENSIONS
UNIVERSAL TROLLEY MODELS A, AA, B, C, E, F & H**

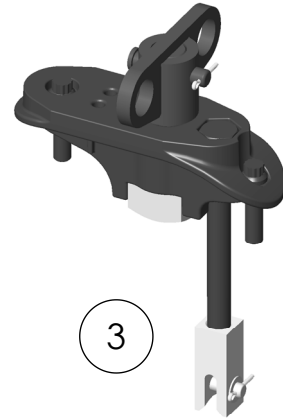
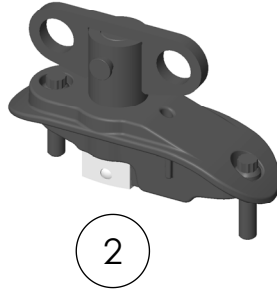

Item No.	Description	Models	Reeving	Part Number
1	UT 1/2 TON SUSPENSION KIT - PARALLEL MOUNT ONLY	A, AA, B, C & F	1	2992NHUT
2	UT 1/2 TON SUSPENSION KIT - CROSS MOUNT ONLY	A, AA, B, C & F	1	2992NHUTC
3	UT 1 TON SUSPENSION KIT - CROSS OR PARALLEL	E & H	2	2993NHUT

LOWER HOOK BLOCKS SINGLE REEVED

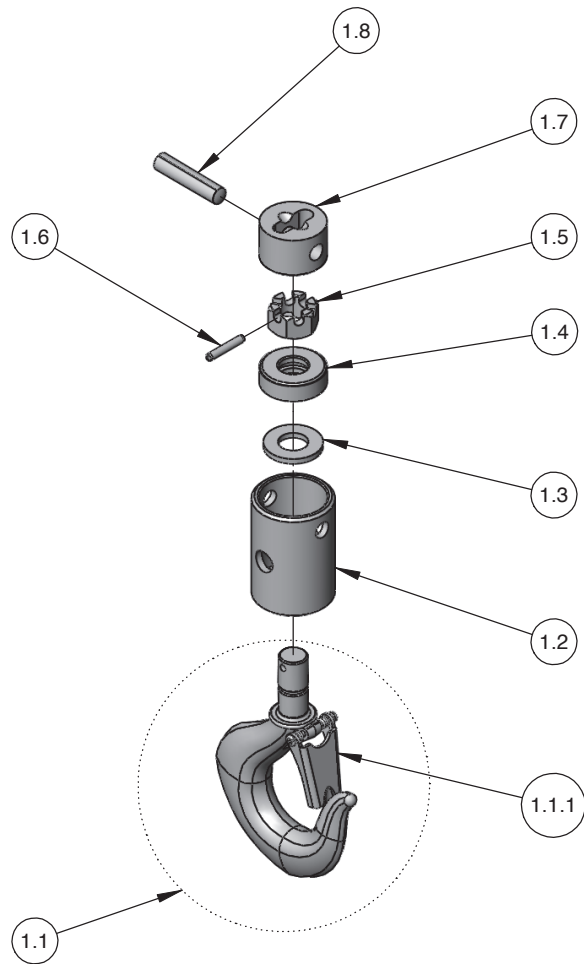

Item No.	Description	Models A, AA, B, C & F	Qty.
1	LOWER HOOK BLOCK ASSEMBLY-COMPLETE WITH LATCH TYPE HOOK	*28683	1
1.1	LOWER HOOK WITH LATCH	28686	1
	LATCHLOK TYPE HOOK	28604	1
1.1.1	LATCH KIT	45661	1
1.2	LOWER HOOK BODY	45401B	1
1.3	LOWER HOOK WASHER	945921	1
1.4	LOWER HOOK THRUST BEARING	88485	1
1.5	LOWER HOOK NUT	982526	1
1.6	LOWER HOOK NUT PIN	983772	1
1.7	LOWER HOOK CHAIN BLOCK	28007	1
1.8	LOWER HOOK CHAIN BLOCK PIN	45943	1

*Contact CM for Latchlok part number

LOWER HOOK BLOCKS DOUBLE REEVED

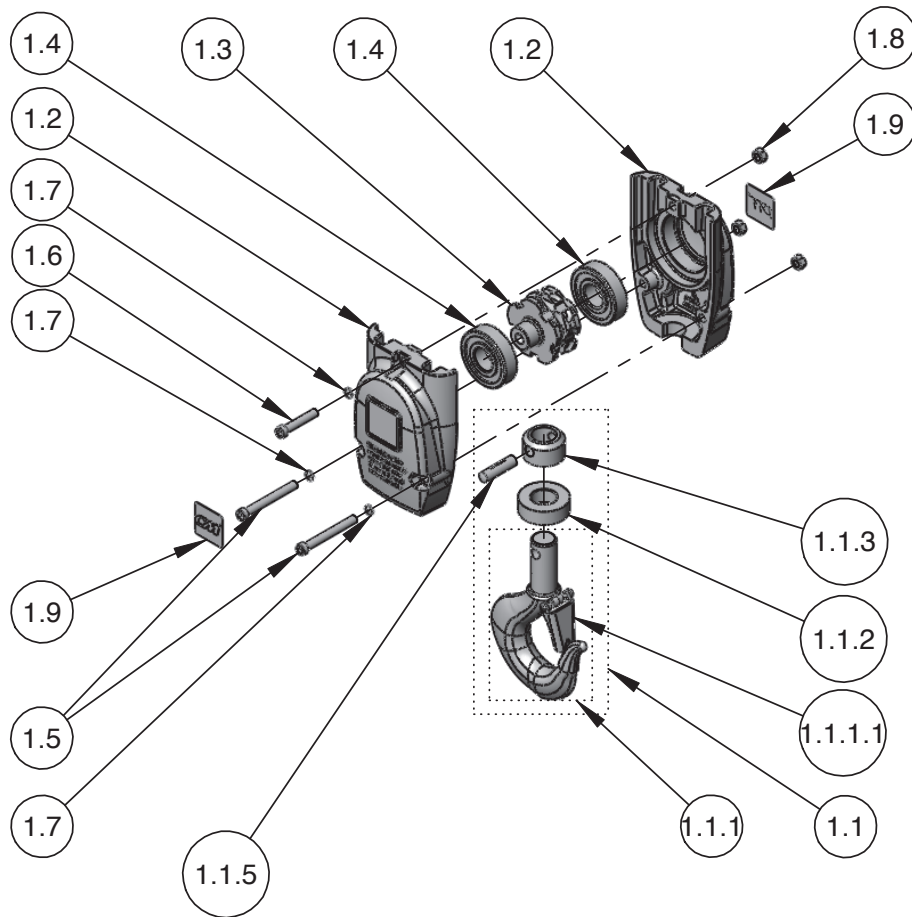

DOUBLE-REEVED

LOWER HOOK BLOCKS DOUBLE REEVED

Item No.	Description	Models E & H	Qty.
1	LOWER HOOK BLOCK ASSEMBLY-COMplete WITH LATCH TYPE HOOK	*00000272B	1
1.1	LOWER HOOK ASSEMBLY WITH LATCH AND BRG	28665	1
	LATCHLOK TYPE HOOK ASSEMBLY WITH BRG	-	1
1.1.1	LOWER HOOK WITH LATCH	28687B	1
	LATCHLOK TYPE HOOK	28603	1
1.1.1.1	LATCH KIT	45662	1
1.1.2	LOWER HOOK THRUST BEARING	88478	1
1.1.3	LOWER HOOK COLLAR	45385	1
1.1.4	-	-	1
1.1.5	LOWER HOOK PIN	45941	1
1.2	HOOK BLOCK (ORDER IN PAIRS)	00000271B	2
1.3	HOOK BLOCK SHEAVE	00000273	1
1.4	HOOK BLOCK SHEAVE BEARING	88429	2
1.5	HOOK BLOCK SCREW-LONG	982066	2
1.6	HOOK BLOCK SCREW-SHORT	986191	1
1.7	HOOK BLOCK LOCK WASHER	940802	3
1.8	HOOK BLOCK NUT	982514	3
1.9	HOOK BLOCK LABEL	00000766	2

*Contact CM for Latchlok part number

DC BRAKE A, AA, B, C, E, F & H

BACK FRAME
w/ DRIVE SHAFT
& O-RING

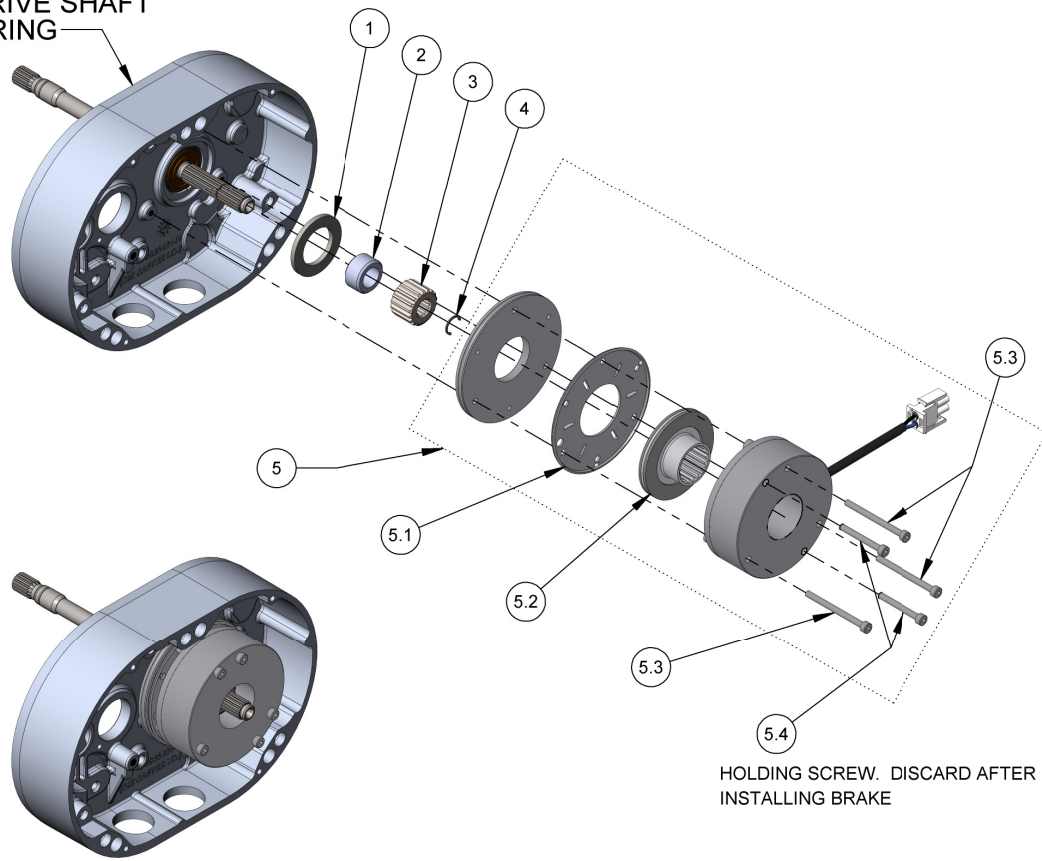

HOLDING SCREW. DISCARD AFTER
INSTALLING BRAKE

Item No.	Part Number	Description	Qty.
1	10001309	SPACER	1
2	00001432	HUB SPACER V1 DC BRAKE	1
3	192042811	HUB, BRAKE #6, INTORQ	1
4	10409710	ROTOR CLIP RETAINING RING	1
5	192042664	BRAKE, 205VDC, #6 INTORQ	1
5.1	192043933	FRICION PLATE	1
5.2	192043932	FRICION DISC (ROTOR)	1
5.3	192043930	SCREW, M4 X 50 SHCS	3
5.4	192043929	SCREW, M4 X 35 SHCS	2

BACKFRAME COVER ASSEMBLY MODELS A, AA, B, C, E, F & H

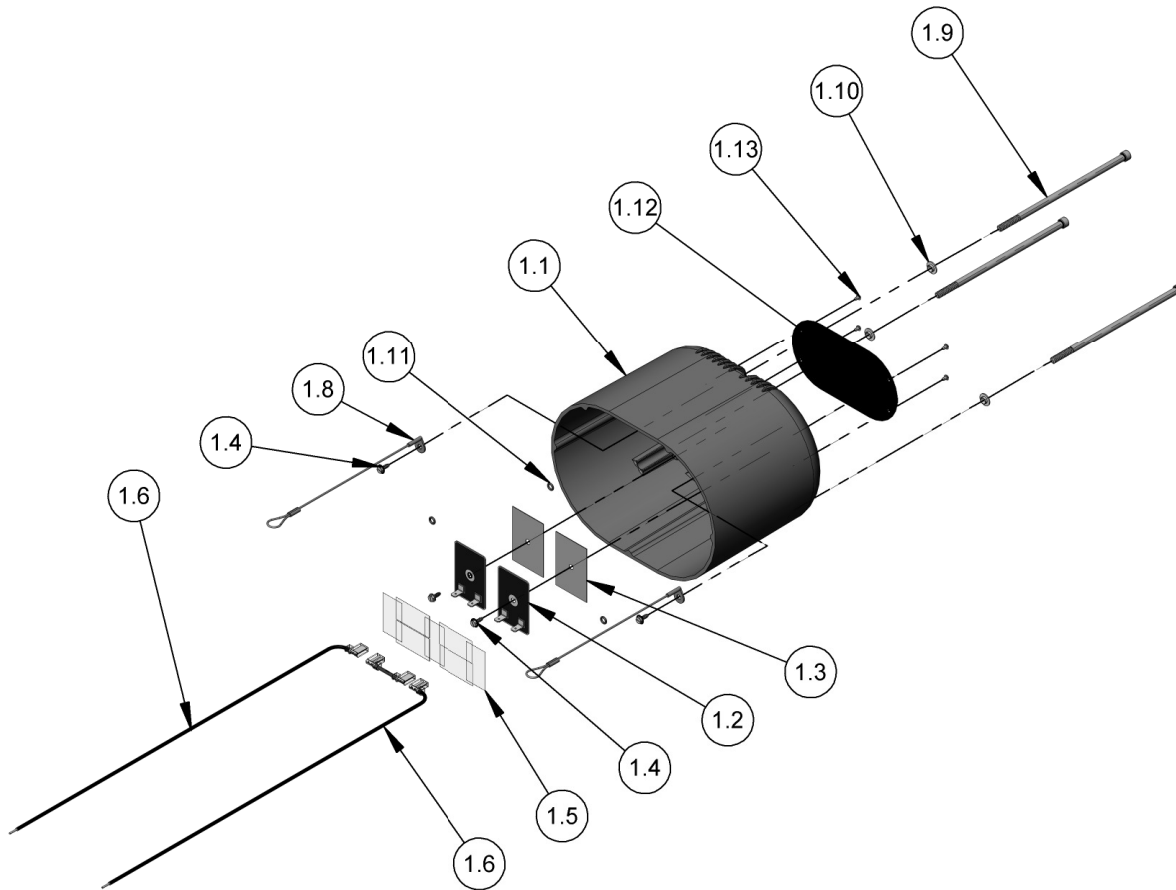

Item No.	Part Number	Description	Qty.
1	192046013	BRAKE COVER-V1 SIA - ORANGE	1
1.1	192042382	ENDCOVER, V1 BRAKE, MACH., ORANGE	1
1.2	192043818	RESISTOR, DB, 200W, 150 OHM	2
1.3	192043819	THERMAL PAD	2
1.4	192045463	SCREW, HEX HEAD, 8-32 THRO FRMNG	4
1.5	192045454	INSULATING TAPE	APPROX. 12.25"
1.6	192045458	JUMPER - DBR LEAD	2
1.7	192045459	JUMPER - DBR	1
1.8	192045460	LANYARD, LOOP TO 90°EYE, 8"	2
1.9	10001653	1/4-20 X 6.5" SKT HD CAP SCREW	3
1.10	982251	WASHER - .252 ID X .19 WALL	3
1.11	00001747	O-RING 008	3
1.12	192045464	LABEL, LODESTAR VS, V1	1
1.13	10001686	LABEL SCREW, #4-24 X .19"LONG	4

COMPLETE CONTROL CORD AND STATION ASSEMBLY VFD, 2-SPEED HOIST CONTROL STATION

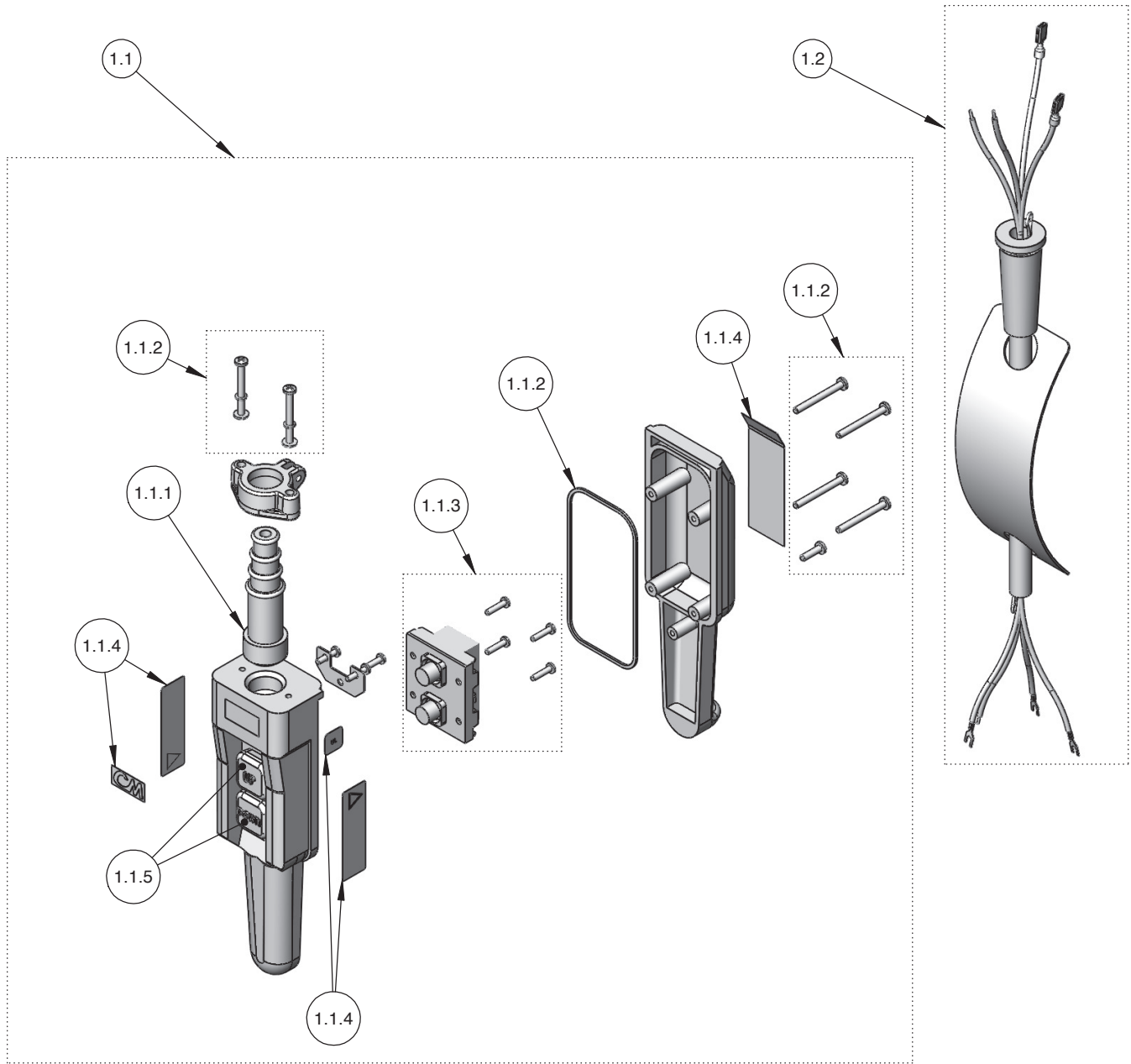

Item No.	Part Number	Description	Qty.
1	23659706	STATION ASSEMBLY AND CONTROL CORD FOR 10 FOOT LIFT	1
	23659711	STATION ASSEMBLY AND CONTROL CORD FOR 15 FOOT LIFT	
	23659716	STATION ASSEMBLY AND CONTROL CORD FOR 20 FOOT LIFT	
1.1	58273	2 BUTTON CONTROL STATION	1
1.1.1	58278	GROMMET	1
1.1.2	58275	HARDWARE KIT	1
1.1.3	58256	2-SPEED INSERT	1
1.1.4	58276	WARNING LABEL KIT	1
1.1.5	58277	BUTTON LABEL KIT	1
1.2	23661106	CONTROL CORD - 10 FOOT LIFT	1
	23661111	CONTROL CORD - 15 FOOT LIFT	
	23661116	CONTROL CORD - 20 FOOT LIFT	

COMPLETE CONTROL CORD AND STATION ASSEMBLY VFD, 3-SPEED HOIST CONTROL STATION

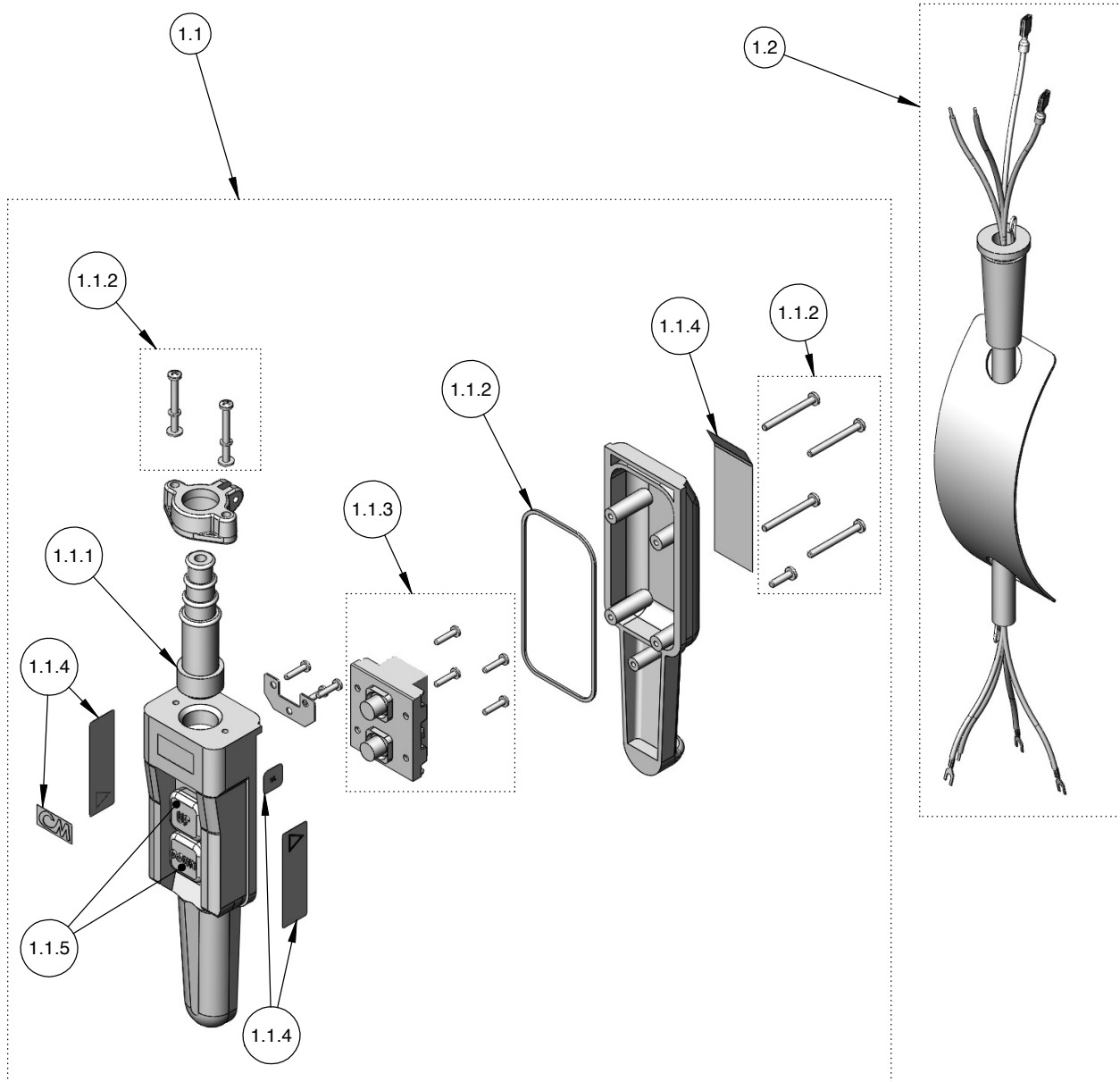

Item No.	Part Number	Description	Qty.
1	23659806	STATION ASSEMBLY AND CONTROL CORD FOR 10 FOOT LIFT	1
	23659811	STATION ASSEMBLY AND CONTROL CORD FOR 15 FOOT LIFT	
	23659816	STATION ASSEMBLY AND CONTROL CORD FOR 20 FOOT LIFT	
1.1	58296	2 BUTTON CONTROL STATION	1
1.1.1	58278	GROMMET	1
1.1.2	58275	HARDWARE KIT	1
1.1.3	57803	3-SPEED INSERT	1
1.1.4	58276	WARNING LABEL KIT	1
1.1.5	58277	BUTTON LABEL KIT	1
1.2	23661206	CONTROL CORD - 10 FOOT LIFT	1
	23661211	CONTROL CORD - 15 FOOT LIFT	
	23661216	CONTROL CORD - 20 FOOT LIFT	

CM ROCKET UNIVERSAL PENDANT CONTROL

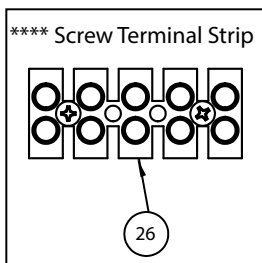
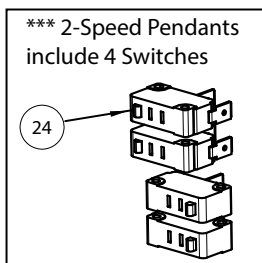
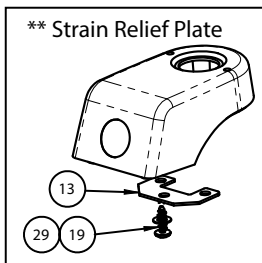
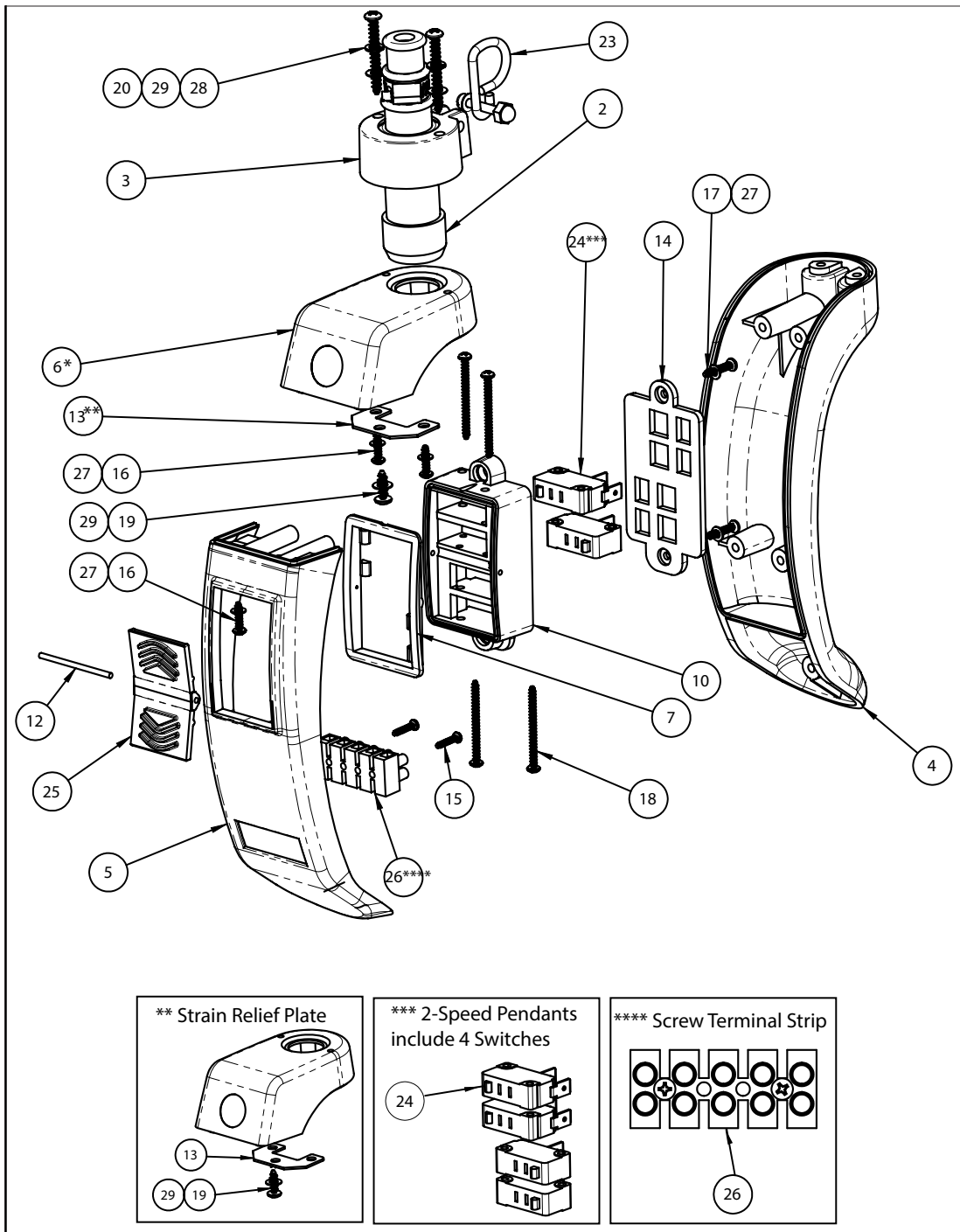

Rocket Universal Pendant Control	
Product Code	Description
ECUR-1S	Rocket Pendant Control - Single-Speed, No E-stop
ECUR-2S	Rocket Pendant Control - 2-Speed, No E-stop
ECUR-1S-25P	25 PACK: Rocket Pendant Control - Single-Speed, No E-stop
ECUR-2S-25P	25 PACK: Rocket Pendant Control - 2-Speed, No E-stop

Product Code	Description
ECUR-0001	Strain Relief Kit
ECUR-0010	Switch Repair Kit, 2-Speed, 4 Switch
ECUR-0011	Switch Repair Kit, Single-Speed, 2 Switch
ECUR-0020	Enclosure Repair Kit, No E-Stop
ECUR-0021	Enclosure Repair Kit, With E-Stop
ECUR-0030	Label Kit
23608124	Emergency Stop Push Button
23608110	Rocket Bushing CBL 13.3-16.5mm

5" METAL AND FABRIC CHAIN CONTAINER INSTALLATION INSTRUCTIONS

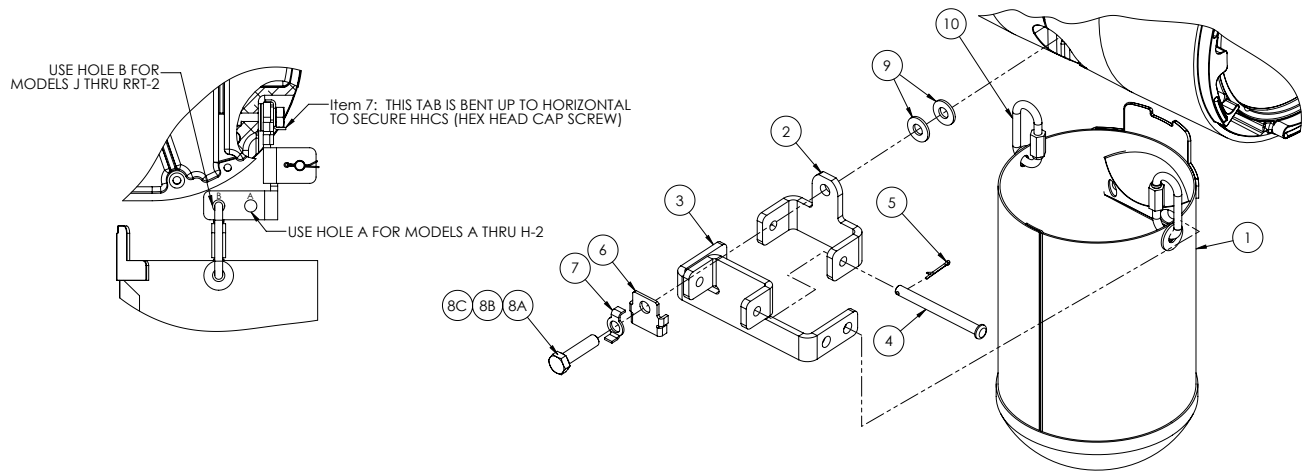

Chain Container Bucket Length Vs. Model And Lift (Table A)

A Thru C2 & F Thru F-2	E, E-2, H, & H-2	J Thru LL-2	R Thru Rr-2	RT Thru RRT-2	Bucket Length (Inches)	Metal Container Part Numbers	Fabric Container Part Numbers
LIFT IN FEET					-	-	-
10	5 -	-	-	-	8	2450	3813PNH
10 - 20	5 - 10	10	5	-	11	2451	3814PNH
20 - 30	10 - 15	10 - 15	5 - 7.5	5	14	2452	3810PNH
30 - 40	15 - 20	15 - 20	7.5 - 10	5 - 6.3	17	2453	3815PNH
40 - 50	20 - 25	20 - 25	10 - 12.5	6.3 - 8.3	20	2454	3816PNH
50 - 60	25 - 30	25 - 30	12.5 - 15	8.3 - 10	23	2455	3811PNH
60 - 90	30 - 45	30 - 40	15 - 20	10 - 13.3	31	2456	3817PNH
90 - 100	45 - 50	40 - 60	20 - 30	13.3 - 20	36	2457	3812PNH
100 - 140	50 - 70	60 - 90	30 - 45	20 - 30	48	2458	3818PNH

Item No.	Part Number	Description	Qty.
1	-	CHAIN CONTAINER BUCKET/BAG	1
-	-	CHAIN CONTAINER KIT 5" DIAMETER (CONSIST OF THE BELOW ITEMS)	1
2	-	UPPER BRACKET	1
3	-	LOWER BRACKET	1
4	-	PIN CLEVIS	1
5	-	COTTER PIN-1/16 X 3/4 LG	1
6	-	ADAPTER (V2) FOR MODELS J THRU RRT-2	1
7	-	SCREW HEAD RETAINER	1
8A	24650	HHCS 5/16-18 UNC-2A X 1 1/4 USE ONLY ON HOIST WITH SERIAL # BEGINNING WITH "NL" MODELS J THRU RRT AND WJ & WR	1
8B	-	HHCS 1/4-20 UNC-2A X 1 1 USE ONLY ON MODELS A THRU H-2	1
8C	-	HHCS 5/16-18 UNC-2A X 1 USE ONLY ON HOIST WITH SERIAL # BEGINNING WITH "L" OR "LW" MODELS J-RRT AND WJ & WR	1
9	-	WASHER 5/16 X 11/16 X .065 SAE USED ONLY ON HOIST WITH SERIAL # BEGINNING WITH "NL"	2
10	-	QUICK LINK	2

LUBRICANTS

Part Number for Packaged Lubricants Used in the Lodestar Electric Chain Hoists (Refer to page 17 for Lubrication Instructions)		
Lubricant Usage	Type of Lubricant	Part Numbers and Packaged Quantity of Lubricants
Hoist Gears	Grease (Special)	Models A to H uses 28605
Load Chain	Oil	28608 for 1 Pint Can 28619 for 1 Gal Can
Lower Hook Thrust Bearing	*Oil	Heavy Machine Oil obtain locally

*These oils are not furnished by CM in Packaged Quantities. When ordering lubricants, specify the type of lubricant, part number and packages quantity required.

Touch-up Paints for Lodestar Electric Chain Hoists:

Hoist Order *(1) case (12-12 oz. Aerosol Cans) of Black Touch-up paints Part Number 84189.

Hoist Order *(1) case (12-12 oz. Aerosol Cans) of Orange Touch-Up paint Part Number 84190.

*Touch-up paints are only available in case quantities.

NOTE: When painting hoists, also order warning labels, identification labels, etc. that may be coated during painting.

RECOMMENDED SPARE PARTS

To insure continued service of the Lodestar Hoist, the following is a list of parts that are recommended to be kept on hand at all times to replace parts that have worn or failed.

Part Description	Models A-H	Qty Required For Each Hoist
VFD Assembly-230V (includes mounting plate and relay harness)	192045999	1
VFD Assembly-460V (includes mounting plate and relay harness)	192046000	
Brake Relay Assembly - 230V	192046018	1
Brake Relay Assembly - 460V	192046019	
VFD to Relay Harness	192045996	1
Limit Switch Encoder Assembly	192046377	1
Suspension Bolts	987554	2
2-speed CM Control Station	58273	1
3-speed CM Control Station	58296	1
2-speed Rocket Control Station	ECUR-2S	1

HOIST WARRANTY

WARRANTY AND LIMITATION OF REMEDY AND LIABILITY

INDEMNIFICATION AND SAFE OPERATION

Buyer shall comply with and require its employees to comply with directions set forth in instructions and manuals furnished by Seller and shall use and require its employees to follow such instructions and manuals and to use reasonable care in the use and maintenance of the goods. Buyer shall not remove or permit anyone to remove any warning or instruction signs on the goods. In the event of personal injury or damage to property or business arising from the use of the goods, Buyer shall within 48 hours thereafter give Seller written notice of such injury or damage. Buyer shall cooperate with Seller in investigating any such injury or damage and in the defense of any claims arising therefrom.

If Buyer fails to comply with this section or if any injury or damage is caused, in whole or in part, by Buyer's failure to comply with applicable federal or state safety requirements, Buyer shall indemnify and hold Seller harmless against any claims, loss or expense for injury or damage arising from the use of the goods.

CMCO Warranty (HOISTS)

A. Columbus McKinnon Corporation ("Seller") warrants to the original end user ("Buyer") that: (a) for a period of one (1) year from the date of Seller's delivery of the goods (collectively, the "Goods") to the carrier, the electrical components of the Goods will be free from defects in workmanship and materials; and (b) for the life of the Goods, the mechanical components of the Goods will be free from defects in workmanship and materials.

B. IN THE EVENT OF ANY BREACH OF SUCH WARRANTY, SELLER'S SOLE OBLIGATION SHALL BE EXCLUSIVELY LIMITED TO, AT THE OPTION OF SELLER, REPAIR OR REPLACEMENT, F.O.B. SELLER'S POINT OF SHIPMENT, OF ANY GOODS THAT SELLER DETERMINES TO HAVE BEEN DEFECTIVE OR, IF SELLER DETERMINES THAT SUCH REPAIR OR REPLACEMENT IS NOT FEASIBLE, TO A REFUND OF THE PURCHASE PRICE UPON RETURN OF THE GOODS TO SELLER. NO CLAIM AGAINST SELLER FOR ANY BREACH OF (i) SUCH WARRANTY WITH RESPECT TO THE ELECTRICAL COMPONENTS OF ANY GOOD SHALL BE VALID OR ENFORCEABLE UNLESS BUYER'S WRITTEN NOTICE THEREOF IS RECEIVED BY SELLER WITHIN ONE (1) YEAR FROM THE DATE OF SELLER'S DELIVERY TO THE CARRIER AND (ii) SUCH WARRANTY WITH RESPECT TO THE MECHANICAL COMPONENTS OF ANY GOOD SHALL BE VALID OR ENFORCEABLE UNLESS BUYER'S WRITTEN NOTICE THEREOF IS RECEIVED BY SELLER WITHIN ONE (1) YEAR FROM THE DATE THE DATE ANY ALLEGED CLAIM ACCRUES. EXCEPT FOR THE WARRANTY SET FORTH ABOVE, SELLER MAKES NO OTHER WARRANTIES WITH RESPECT TO THE GOODS, WHETHER EXPRESSED OR IMPLIED, INCLUDING ANY WARRANTIES OF MERCHANTABILITY,

FITNESS FOR A PARTICULAR PURPOSE, QUALITY AND/OR THOSE ARISING BY STATUTE OR OTHERWISE BY LAW OR FROM ANY COURSE OF DEALING OR USE OF TRADE, ALL OF WHICH ARE HEREBY EXPRESSLY DISCLAIMED.

C. IN NO EVENT SHALL SELLER BE LIABLE TO BUYER OR ANY THIRD PARTY WITH RESPECT TO ANY GOOD, WHETHER IN CONTRACT, TORT OR OTHER THEORY OF LAW, FOR LOSS OF PROFITS OR LOSS OF USE, OR FOR ANY INCIDENTAL, CONSEQUENTIAL, SPECIAL, DIRECT OR INDIRECT DAMAGES, HOWSOEVER CAUSED. SELLER'S MAXIMUM LIABILITY TO BUYER WITH RESPECT TO THE GOODS SHALL IN NO EVENT EXCEED THE PRICE PAID BY BUYER FOR THE GOODS THAT ARE THE SUBJECT OF THE APPLICABLE CLAIM.

D. Seller shall not be liable for any damage, injury or loss arising out of the use of the Goods if, prior to such damage, injury or loss, such Goods are: (1) damaged or misused following Seller's delivery to the carrier; (2) not maintained, inspected, or used in compliance with applicable law and Seller's written instructions and recommendations; or (3) installed, repaired, altered or modified without compliance with such laws, instructions or recommendations.

E. This warranty is limited and provided only to the original end user. **Each Good must be registered within sixty (60) days of receipt of each product to establish eligibility.** Please register at www.cmworks.com/hoist-warranty-registration or submit registration card via US mail.

F. Any action against Seller for breach of warranty, negligence or otherwise in connection with the electrical components of any Good must be commenced by Buyer within one (1) year after: (a) the date any alleged claim accrues; or (b) the date of delivery of the Goods to Buyer, whichever is earlier. Any action against Seller for breach of warranty, negligence or otherwise in connection with the mechanical components of any Good must be commenced by Buyer within one (1) year after the date any alleged claim accrues.

WARNING

Alterations or modifications of equipment and use of non-factory repair parts can lead to dangerous operation and injury.

TO AVOID INJURY:

- Do not alter or modify equipment.
- Do use only factory replacement parts.

MAGNETEK LIMITED WARRANTY

Magnetek, hereafter referred to as Company, guarantees that the drive has been manufactured by it against any defects of material and/or workmanship for a period of two years from the date of shipment. Company makes NO OTHER WARRANTY, EXPRESSED OR IMPLIED, AS TO THE MERCHANTABILITY OR FITNESS OF THE ITEMS FOR THEIR INTENDED USE OR AS TO THEIR PERFORMANCE. Any statement, description or specification in Company's literature is for the sole purpose of identification of items sold by the Company and imparts no guarantee, warranty or undertaking by company of any kind. Components and accessories not manufactured by Magnetek are not included in this warranty and are warranted separately by their respective manufacturers.

Company's sole liability shall be to repair at its factory, or replace any item returned to it within two years from date of shipment, which Company finds to contain defective material or workmanship. All items to be repaired or replaced shall be shipped to Company (Note: return authorization by Company is required) within said two year period, freight prepaid, as a condition to repair or replace defective material or workmanship. Company's herein assumed responsibility does not cover defects resulting from improper installation, maintenance, or improper use. Any corrective maintenance performed by anyone other than the Company during the warranty period shall void the warranty. Company shall not be liable for damages of any kind from any cause whatsoever beyond the price of the defective Company supplied items involved.

Company shall not be liable for economic loss, property damage, or other consequential damages or physical injury sustained by the purchaser or by any third party as a result of the use of any Company supplied items or material.

Company neither assumes nor authorizes any other person to assume for Company any other liability in connection with the sale or use of items sold by Company.

Materials or items may not be returned for credit, without the prior written consent of the Company. Any authorized return of materials or items shall be subject to a restocking charge equal to 25% of the net invoiced amount (\$100 minimum charge for all control products) after Company determines that the material or item is in resalable condition. If upon receipt of the material or items returned, the Company determines that said material or items cannot be resold without alteration or service, the Company reserves the right to reject the returned materials or items and to send the same back to said purchaser at purchaser's expense.

Any claim for errors in shipment or for material or time shortages must be received by Company within 30 days of shipment and must be accompanied by copies of the bill of lading and packing slip.

Refer to hoist manual for CM's Repair/Replacement policy that applies to the hoist.

Distributed by Tri-State Equipment Company Inc.
sales@tsoverheadcrane.com
www.tsoverheadcrane.com
Tel: (314) 869-7200



COLUMBUS McKINNON
CORPORATION

FAMILY OF BRANDS

