

OPERATION, SERVICE & PARTS MANUAL



Before installing hoist, fill in the information below. Refer to the Hoist and Motor data plates.

Model No. _____

Serial No. _____

Purchase Date _____

Voltage _____

Rated Load _____

SERIES 700

SHAW-BOX[®]

WIRE ROPE ELECTRIC HOISTS

INCLUDING

WEIGHT WATCHER OVERLOAD CLUTCH MODELS

RATED LOADS THRU 25 TONS

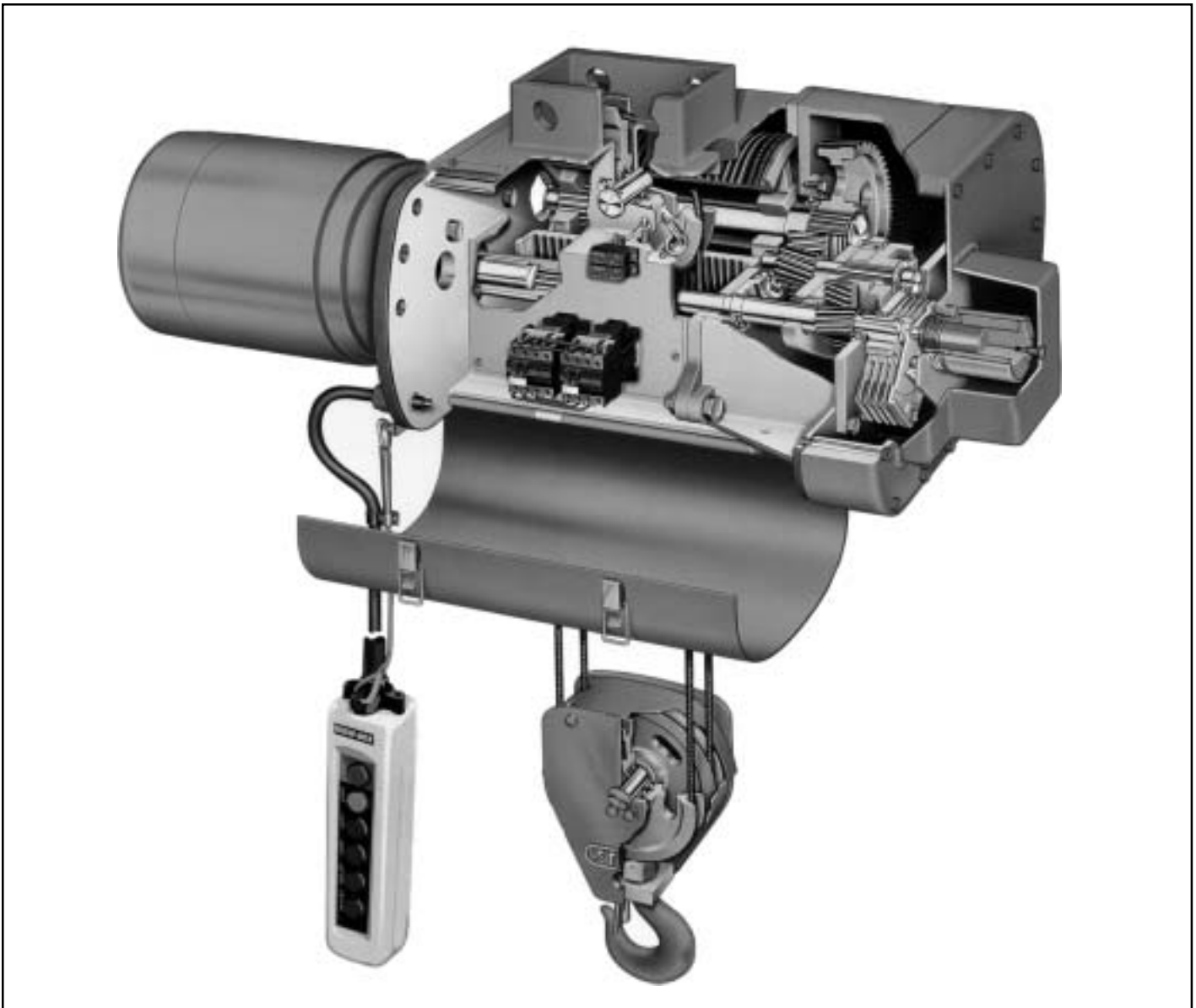

Figure 1-1. Cutaway View of Standard Series “700” SHAW-BOX Electric Hoist

This cutaway view illustrates the high quality and precision construction of your new SHAW-BOX electric hoist. An examination of its makeup will show it is designed and built to give you long service life with a minimum of attention. Notice that it has wide-faced helical gearing made of heat-treated steel, ball bearings throughout, large diameter grooved rope drum and large lower block rope sheave. In addition, this hoist offers unusually easy accessibility to all working parts. It is designed so that you needn't take your hoist down for servicing. A hinged side cover gives quick access to electrical components. Removable lightweight aluminum end covers provide full access to brake mechanism, motor brake, load brake and gearing.

FOREWORD

This book contains important information to help you install, operate, maintain and service your new SHAWBOX electric hoist. We recommend that you study its contents thoroughly before putting the hoist into use. Read ANSI B30.16 safety code for hoists. Then, thru proper installation, application of correct operating procedures, and by practicing the recommended maintenance suggestions you can expect maximum lifting service from the hoist.

It will likely be a long time before parts information found in Section IX is needed; therefore, after the hoist is installed and you have completely familiarized yourself with operation and

preventive maintenance procedures, we suggest that this book be carefully filed for future reference.

When ordering replacement parts from this book, it will be necessary that you include, with your order, the Hoist Serial Number, Model Number and Catalog Number which is found on the nameplate attached to motor end of hoist (Figure 4-1). For your convenience, a space has been provided on the front cover of this Manual for entering this information. We recommend that you fill it out immediately so it is readily at hand when needed.

FOREWORD (Continued)

The contents of this manual are of necessity, general in nature and may cover features not incorporated on your hoist; or, you may have ordered features not covered by this manual. Therefore, the user must exercise care in applying instructions given in this manual. If specific information not in this manual is required, contact the factory at Muskegon, Michigan 49443.

THE INFORMATION CONTAINED IN THIS MANUAL IS FOR INFORMATIONAL PURPOSES ONLY AND LIFTTECH

INTERNATIONAL DOES NOT WARRANT OR OTHERWISE GUARANTEE (IMPLIEDLY OR EXPRESSLY) ANYTHING OTHER THAN THE COMPONENTS THAT LIFT-TECH MANUFACTURES AND ASSUMES NO LEGAL RESPONSIBILITY (INCLUDING, BUT NOT LIMITED TO CONSEQUENTIAL DAMAGES) FOR INFORMATION CONTAINED IN THIS MANUAL.

NOTICE: Information contained in this book is subject to change without notice.

INDEX		Page
SECTION I GENERAL DESCRIPTION		
Paragraph 1-1 General		4
Paragraph 1-2 Basic Construction		4
SECTION II INSTALLATION		
Paragraph 2-1 General		4
Paragraph 2-2 Suspending Hoist		4
Paragraph 2-3 Connecting Hoist to Electrical Service		5
Paragraph 2-4 Pre-Operation Checks		5
SECTION III OPERATION		
Paragraph 3-1 General		7
Paragraph 3-2 Push Button Operation		7
Paragraph 3-3 Overload Clutch Operation		7
Paragraph 3-4 Operating Precautions		7
SECTION IV LUBRICATION		
Paragraph 4-1 General		8
Paragraph 4-2 Change Gearcase Oil		8
Paragraph 4-3 Lubricate Hoist Cable		8
Paragraph 4-4 Lubricate Upper Sheave & Lower Block Assembly		8
Paragraph 4-5 Limit Stop Lever Lubrication		8
Paragraph 4-6 Lubricate Limit Switch		8
SECTION V INSPECTION AND PREVENTATIVE MAINTENANCE		
Paragraph 5-1 General		9
Paragraph 5-2 Inspect Lower Block		10
Paragraph 5-3 Inspect Upper Block and Hoist Suspension		10
Paragraph 5-4 Inspect Electrical Controls		12
Paragraph 5-5 Inspect Motor Brake and Actuating Mechanism		12
Paragraph 5-6 Inspect Mechanical Load Brake and Gearing		12
Paragraph 5-7 Inspect Rope Drum and Shaft		14
Paragraph 5-8 Rope Inspection, Replacement & Maintenance		14
Paragraph 5-9 Rope Reeving		15
Paragraph 5-10 Testing Hoist		20
SECTION VI TROUBLESHOOTING CHART		20
SECTION VII ADJUSTMENTS		
Paragraph 7-1 Mechanical Load Brake		22
Paragraph 7-2 Motor Brake Adjustment		22
Paragraph 7-3 Block Operated Limit Switch		22
Paragraph 7-4 Geared Rotary Limit Switch Adjustment		23
Paragraph 7-5 Overload Clutch Adjustment and Testing		23
Paragraph 7-6 Shortening of Push Button Cable		25
SECTION VIII WIRING DIAGRAMS		25
SECTION IX PARTS LIST		
Paragraph 9-1 General		25
Paragraph 9-2 List of Parts Illustrations		25

No part of this document may be reproduced in any form, in an electronic retrieval system or otherwise, without prior written permission of the publisher.

SECTION I - GENERAL DESCRIPTION

1-1. GENERAL. SHAW-BOX Series "700" electric hoists are wire rope and drum type hoists which are manufactured in two basic models: A standard model, available in four conventional suspensions (Lug Mounted, Push Trolley, Hand Geared Trolley and Motor Driven Trolley); and, a low headroom model with three special low-headroom design trolley suspensions (Push, Hand Geared and Motor Driven types). The standard model hoist comes in eleven load sizes, ranging from 2 thru 20 tons, with various lifts and lifting speeds, while the low headroom model comes in 7 load sizes, from 2 thru 10 tons, and various lifts and lifting speeds. Both of the basic models are available with single or two-speed lifting control. Deck mounted and base mounted hoists are also available as modifications of the basic hoist models. Deck mounted hoists are available thru 20 ton rated load.

NOTICE

SHAW-BOX hoists thru 15 tons are available with an optional built-in mechanical overload clutch. Hoists having this device are identified with words "WEIGHT WATCHER" on the hoist.

The "WEIGHT WATCHER" overload limiting device permits operation of your hoist within its rated load and helps prevent lifting of excessive loads which could cause permanent deformation of a properly maintained hoist or trolley.

1-2. BASIC CONSTRUCTION. Series "700" standard model and low headroom model electric hoists are of the same basic construction, differing primarily in the suspension method and rope reeving. They consist of a rugged steel frame which houses a lifting drum and serves as the suspension for carrying the entire hoist load. A mounting lug, for attaching the hoist trolley or mounting to an overhead suspension (standard model), is located on the top of the frame. An aluminum alloy gearcase, attached to one end of the hoist frame, houses a two-reduction gear train and a mechanical load brake. A gearcase cover and a brake cover, both of aluminum alloy, mounted on the end of the gearcase, houses an automatic motor brake. An electric driving motor is mounted at the other end of the hoist frame. Electrical system components, located in a compartment at the front of the hoist frame, control operation and rotating direction of driving motor. Hoisting cable and an enclosed lower block assembly is used for lifting loads. An upper limit stop is used to limit the travel of the lower block in the raising direction to protect hoist from damage. A push button control station for operating the hoist is suspended on a wire strain cable attached to hoist frame at the motor end of the hoist.

SECTION II - INSTALLATION

2-1. GENERAL. SHAW-BOX Series 700" electric hoists are lubricated and tested before being shipped from the factory. To place hoist in service, attach a suitable suspension (Paragraph 2-2), connect to electrical service (Paragraph 2-3) and perform pre-operation tests and checks (Paragraph 2-4).

WARNING

Before attempting installation of hoist or trolley, the main power switch must be locked in the open position (off).

2-2. SUSPENDING HOIST. Hoist may be suspended in a fixed location servicing only the area directly below the hoist (Lug Mounted). Hoist may be attached to a moveable trolley or trolleys which in turn may be mounted on an I-beam attached to a building or crane, servicing a large area (Trolley Mounted).

- a. Lug Mounted hoists attach to adequate supports welded or bolted to a building or other structure. The supporting structure must have sufficient strength with appropriate safety factor, to support the weight of the hoist and rated load as well as other loads to which the supporting structure may be subjected.

WARNING

Design and installation of hoist support shall be performed only by qualified persons.

Steel angles or plates used to suspend hoist should be spaced as close to the hoist suspension lug as possible. Mounting bolts or threaded studs, attaching hoist to mounting structure, shall have a diameter not less than recommended by manufacturer and material equivalent to ASTM A 325. Make certain that mounting bolts or studs are long enough so that the threads do not engage the mounting support and that mounting bolts or studs are secured with nuts and lockwashers, selflocking nuts or cross bolting, if unthreaded.

- b. Trolley Mounted hoists are attached to moveable trolleys. If hoist is mounted on an existing trolley, a qualified person shall determine that the trolley and its supporting structure are adequate to support the rated load and weight of the hoist. Hoist/trolley units may be shipped from the factory with trolley packaged separately. If the trolley can be installed directly over the end of the supporting beam, assemble trolley to hoist. Be certain that the spacing between wheel flanges, after assembly, is 1/4" greater than exact width of beam flange. (See Figure 2-1 below and instruction sheet furnished with trolley.) Using proper equipment, carefully lift trolley and hoist and install on end of beam.

For trolleys which are to be mounted along the span of a beam not having open ends, measure exact width of beam flange and assemble trolley to hoist so that spacing between wheel flanges is 1/4" (see Figure 2-1) greater than beam width (3/8" if beam has curves). This is accomplished by rearranging the spacer washers on the bolts connecting trolley side plates to hoist mounting lug. If trolley is shipped separate from hoist, see instruction sheets furnished with trolley for orientation and installation.

When proper spacing has been determined, loosen mounting nuts (Item 1, Figure 2-1) to allow trolley wheels to spread far enough to pass over edges of beam flange. (Some installations may require complete removal of one trolley side plate.) Using adequate equipment carefully lift the hoist and trolley so the wheel treads will rest on the lower beam flange. Replace side plate and washers if removed for installation. Replace suspension stud nuts.

⚠ CAUTION

Recheck spacer washers to make certain that the number of washers between the side plate and hoist suspension lug are equal, and also the number on the outside of each side plate are equal. The suspension stud nuts should only be snugged up on the lockwashers until a load has been applied on the hook. A partial load (approx. 25 percent rated hoist capacity) placed on the hook will properly seat hoist in the trolley. Tighten suspension stud nuts only after hoist has been properly seated in the trolley.

⚠ WARNING

Mounting of the hoist/trolley unit on the monorail and final pre-operation inspection shall be performed only by qualified persons properly supervised.

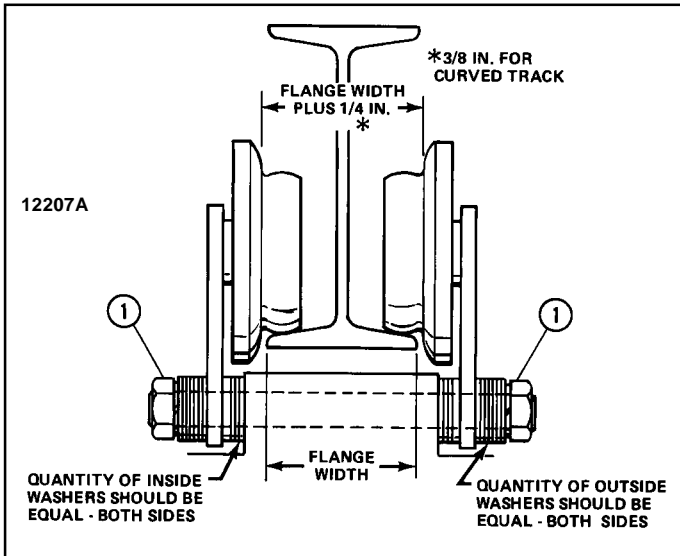

Figure 2-1. Sectional View of Trolley showing proper wheel and washer spacing

2-3. CONNECTING HOIST TO ELECTRICAL SERVICE.

Electrical service to the hoist may be power cable or a guarded system having sliding shoe or wheel type collectors.

⚠ WARNING

Be certain that electrical power supply is OFF and locked in the open position before attempting any electrical connections to the hoist. This equipment must be effectively grounded according to the National Electric Code, or other applicable codes. If the grounding method used is through the trolley wheels, then each section of track must be grounded by metal-to-metal connection to the building ground. Certain environments may prevent proper grounding by this means. In this case a separate grounding conductor should be provided.

- a. Follow national, state and local electrical codes when providing electrical service to the hoist.

⚠ CAUTION

Power supply to the hoist and/or trolley must be the same voltage, frequency and phase that is specified on the hoist and trolley nameplates. Single speed hoists are reconnectable for use on either 460 V. or 230 V. Check terminal board connections on dual voltage hoists with wiring diagram to make certain that the motor, transformer and brake leads are located on proper terminals.

- b. Make electrical connections using the appropriate wiring diagrams furnished with the hoist. All electrical connections, including connections to collectors or power cord shall be made only by qualified journeyman electricians.
- c. When trolley is shipped separate from hoists, see special instructions furnished with trolley for orientation and installation.
- d. For deck mounted three speed hoists, secondary resistors are furnished. These are to be mounted by the customer to suit his requirements. Since resistors generate heat, they are to be located outside of the control panel enclosure in a well ventilated area that will allow the heat to readily dissipate. They must be guarded from accidental contact by personnel (perforated metal covers are often used). Provision must be made to prevent molten metal from falling on personnel (drip trays may be provided).

⚠ WARNING

Failure to properly mount resistors may be hazardous to personnel and equipment.

2-4. PRE-OPERATION CHECKS.

- a. Check Oil Level. (Figure 4-1) The gearcase has been filled with oil to proper level and grease points for upper and lower sheaves (when so equipped) have been lubricated at the factory. However, this should be rechecked before operating hoist.

Check oil level by removing plug locate on side of the gearcase adjacent to the embossed words "OIL LEVEL". When properly filled, oil should be level with bottom of tapped hole. Fill to this level with oil as specified in Paragraph 4-2.d. Grease fittings in sheave pin ends should show evidence of grease.

b. Check Push Button Operation and Phasing:

▲WARNING
<p>On three phase hoists it is possible to have "Reverse Phasing" causing the lower block to lower when the "Up" button is depressed. When this condition exists the automatic limit stop switch is inoperative and hoist operation will be dangerous.</p>

To properly check the phase of the hoist, follow steps below:

- (1) With "POWER OFF" operate all the push buttons and determine that they do not bind or stick in any position.

▲WARNING
<p>If any push button binds or sticks in any position - DO NOT TURN POWER ON - determine the cause and correct the malfunction before operating.</p>

- (2) Temporarily connect hoist to power source.
- (3) Operate "UP" button briefly to determine direction of hook travel.
- (4) If hook raises, phase is correct. Turn power off and make temporary connections permanent.
- (5) If hook lowers, hoist is "Reverse Phased." TURN POWER OFF and correct by interchanging any two leads at power source connection. Do not change internal wiring of hoist.

c. Check Limit Switch Operation.

- (1) A block operated upper limit stop (Figure 2-2) is furnished as standard equipment on most Series "700" electric hoists (some long lift and all deck mounted hoists have geared type limit switches as standard). This limit stop is factory set to stop lower block at safest high position, guarding against overtravel and possible damage to hoist. No adjustment can be made. However, the hoist should be tested by jogging lower block against limit weight (Figure 2-2) to be sure the limit switch is functioning properly. When lower block lifts limit weight, hoist will automatically stop. If lower block coasts through the stop limit switch when lifting at maximum height, in most SHAW-BOX hoists a reversing switch will automatically close and reverse direction of motion to lowering.

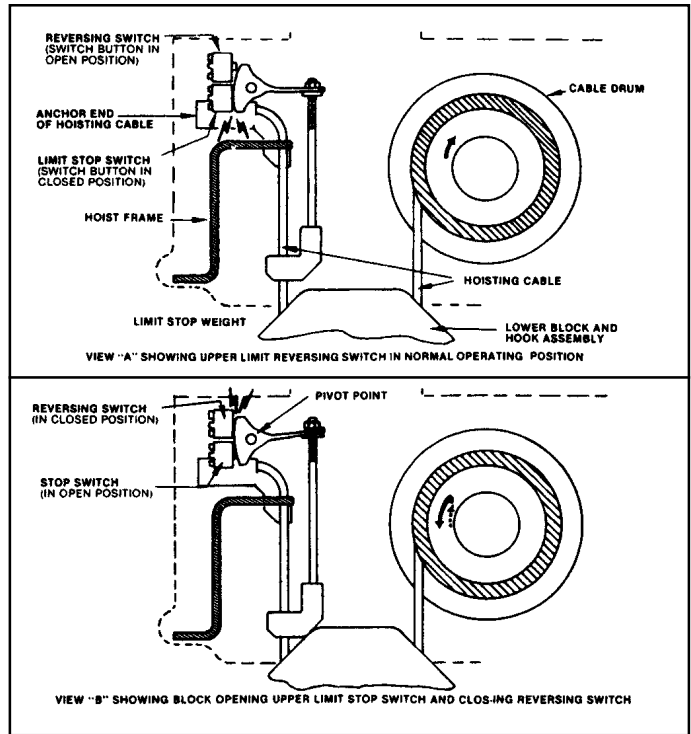

Figure 2-2. Schematic Diagrams of Upper Limit Stop Arrangement

NOTICE

Under normal operating conditions stop hoist travel before engaging limit switches. Limit switches are safety devices and should not be used as normal operating control.

▲WARNING
<p>Some hoists are shipped with the electrical controls loose (disconnected) and will not have the upper and lower limit switches connected. DO NOT OPERATE HOIST UNTIL LIMIT SWITCHES ARE PROPERLY CONNECTED AND ADJUSTED. Failure to do so may allow hoist to be operated beyond proper travel limits which can cause load to drop, resulting in damage to equipment or injury.</p>

- (2) A geared rotary type upper and lower limit switch is provided optionally when both upper and lower limit stops are required (Figure 7-1). This switch is adjustable and although roughly preset by the factory, it should be adjusted at time of installation to the desired high and low limits of lower block travel. Refer to SECTION VII, Paragraph 7-4.

- d. Check Lower Block and Hoisting Cable. Depress "DOWN" push button and run lower block to its lowest position. No less than two wraps shall remain on the drum with the loaded hook in its lowest position, unless hoist is equipped with a lower limit switch in which case no less than one wrap shall remain on the drum. Also check to see that lower block and rope does not twist excessively. If it does twist, to the extent that two ropes rub against each other, disengage rope from the frame anchor and twist rope four or five turns in a direction opposite to that which the

block turns. Reconnect rope to frame anchor, holding firmly to eliminate rope twisting back to its original position. Operate hoist up and down a few times. If lower block still rotates repeat process until twisting is corrected.

- e. Lubricate hoisting Cable. For longer cable life, it is recommended that the cable be lubricated at time of installation by applying a heavy coating grease as outlined in SECTION IV, Paragraph 4-3.

SECTION III - OPERATION

3-1. GENERAL. Operation of Series “700” SHAW-BOX electric hoists is controlled by a convenient pendant push button station. With it, the hoist can be controlled to give fast lifting and lowering; or controlled to lift or lower load in small increments, providing accurate spotting. The push button station has a built-in interlock to prevent depressing opposing buttons simultaneously.

When first using hoist, break in by operating under lighter loads to full travel before applying maximum load.

3-2. PUSH BUTTON OPERATION.

- a. Depress push button marked “UP” to raise load.
- b. Depress push button marked “DOWN” to lower load.
- c. Jogging the push buttons will give “hairline” load movement. The quickness of the depressing motion will determine the amount of movement. Excessive use of this “Jogging” feature will cause premature burning of contact tips and motor overheating.
- d. On two-speed hoists, partial depression of button operates hoist at slow speed; depressing button completely operates hoist at fast speed.

3-3. OVERLOAD CLUTCH OPERATION (optional). The overload clutch is factory preset and tested so that the hoist will lift its full rated load but will refuse to lift overloads which could cause deformation or weakening of your hoist. If the load to be lifted exceeds the clutch setting, the hoist motor will continue to run when the “UP” button is depressed and rotate the load brake gear without lifting the load. Whenever this slipping occurs, immediately release the “UP” push button to prevent overheating of the clutch friction surfaces and the hoist motor.

 WARNING
Always know load to be lifted. Lift-Tech does not recommend lifting loads greater than the rated load of your hoist.

3-4. OPERATING PRECAUTIONS

 WARNING
Equipment covered herein is not designed or suitable as a power source for lifting or lowering persons.

Safe operation of an overhead hoist is the operator's responsibility. Listed below are some basic rules that can make an operator aware of dangerous practices to avoid and precautions to take for his own safety and the safety of others. Observance of these rules in addition to frequent examinations and periodic inspection of the equipment may save injury to personnel and damage to equipment.

- a. **DO read ANSI B30.16 Safety Standard for Overhead Hoists and the Operation, Service and Parts Manual.**
- b. **DO be familiar with hoist operating controls procedures and warnings.**
- c. **DO make sure hook travel is in the same direction as shown on controls.**
- d. **DO make sure hoist limit switches function properly.**
- e. **DO maintain firm footing when operating hoist.**
- f. **DO make sure that load slings or other approved single attachments are properly sized and seated in the hook saddle.**
- g. **DO make sure that the hook latch is closed and not supporting any part of the load.**
- h. **DO make sure that load is free to move and will clear all obstructions.**
- i. **DO take up slack carefully, check load balance, lift a few inches and check load holding action before continuing.**
- j. **DO avoid swinging of load or load hook.**
- k. **DO make sure that all persons stay clear of the suspended load.**
- l. **DO warn personnel of an approaching load.**
- m. **DO protect wire rope from weld splatter or other damaging contaminants.**
- n. **DO promptly report any malfunction, unusual performance, or damage of the hoist.**
- o. **DO inspect hoist regularly, replace damaged or worn parts, and keep appropriate records of maintenance.**
- p. **DO use the hoist manufacturer's recommended parts when repairing a hoist.**
- q. **DO use hook latches.**
- r. **DO apply lubricant to the wire rope as recommended.**
- s. **DO NOT lift more than rated load.**
- t. **DO NOT use the hoist load limiting device to measure the load.**
- u. **DO NOT use damaged hoist or hoist that is not working correctly**
- v. **DO NOT use the hoist with twisted, kinked, damaged or worn wire rope.**
- w. **DO NOT lift a load unless wire rope is properly seated in its groove(s).**
- x. **DO NOT use load rope as a sling or wrap rope around the load.**
- y. **DO NOT lift a load if any binding prevents equal loading on all supporting ropes.**
- z. **DO NOT apply the load to the tip of the hook.**
- aa. **DO NOT operate unless load is centered under hoist.**
- ab. **DO NOT allow your attention to be diverted from operating the hoist.**
- ac. **DO NOT operate the hoist beyond limits of load rope travel.**
- ad. **DO NOT use limit switches as routine operating stops unless recommended. They are emergency devices only.**
- ae. **DO NOT use hoist to lift, support or transport people.**

- af. DO NOT lift loads over people.
- ag. DO NOT leave a suspended load unattended unless specific precautions have been taken.
- ah. DO NOT allow sharp contact between two hoists or between hoist and obstructions.
- ai. DO NOT allow the rope or hook to be used as a ground for welding.
- aj. DO NOT allow the rope or hook to be touched by a live welding electrode.
- ak. DO NOT remove or obscure the warnings on the hoist.
- al. DO NOT adjust or repair a hoist unless qualified to perform hoist maintenance.
- am. DO NOT attempt to lengthen the load rope or repair damaged load rope.
- an. Personnel not physically fit or properly qualified, shall not operate hoist.
- ao. Do not operate hoists unless hook moves in the same direction as indicated on the push button. If opposite direction occurs, see preoperation checks, Paragraph 2-4.b.
- ap. Do not operate hoist unless limit switch is operating properly.
- aq. Center hoist over load before operating. Avoid side pulls and swinging of load or load hook when travelling hoist.

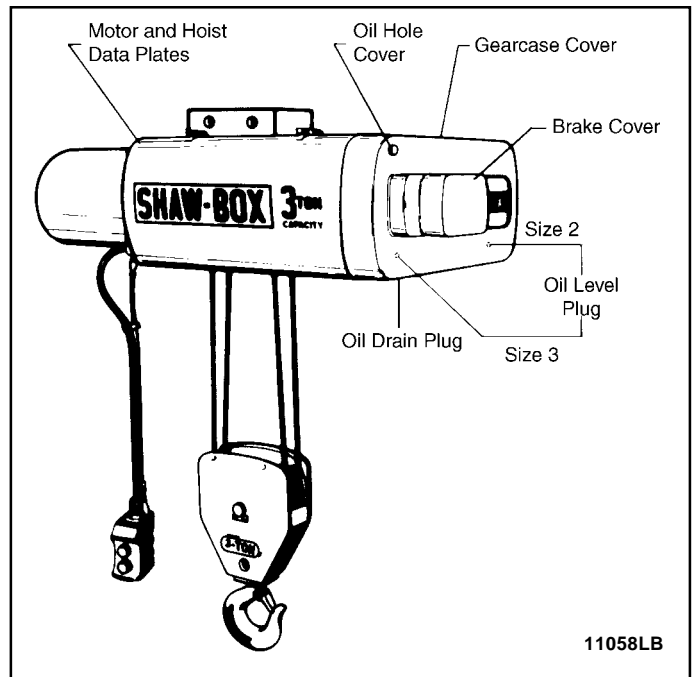

Figure 4-1. View of Hoist Showing Location of Name Plates and Oil Plugs

▲WARNING

Do not operate the hoist with the hoisting rope out of the drum grooves. Such operation may result in the rope breaking and dropping the load which can cause damage to equipment and injury to operator or other personnel. Hoist rope will remain in the drum grooves during proper operation under normal operating conditions, however, slack or kinked rope, excessive side pulls, swinging or jerking of load, or similar abuse, may cause the rope to leave the grooves.

- ar. Observe recommended inspection and maintenance procedures.
- as. Use common sense and best judgement whenever operating a hoist.

SECTION IV - LUBRICATION

4-1. GENERAL. The lubrication services outlined in Paragraphs 4-2 thru 4-6 should be performed at regular intervals to maintain top hoist performance and insure long life. Intervals of at least six (6) months, coinciding with spring and fall seasons, are recommended. The reason for this is that, on hoists installed out-of-doors and in unheated areas, a "cold test" oil is required in cold (below freezing) climates making seasonal changes necessary.

4-2. CHANGE GEARCASE OIL. (Figure 4-1)

- a. Remove oil drain plug from bottom of gearcase and drain out oil.
- b. Flush out hoisting using kerosene. Reinstall drain plug.
- c. Remove oil level plug from front of gearcase cover.

- d. Refill thru filler hole to proper level (bottom of oil level plug hole) using Automatic Transmission Fluid DEXRON III Type, suitable for all temperature ranges. The amount of oil required depends upon overall size of gearcase; two sizes are used for Series "700" hoists. To determine size and amount of oil to add, measure width of hoist at gearcase cover. If the width is 24-3/4 inches, add 6 quarts of oil; and if 34-1/4 inches, add 18 quarts.

4-3. LUBRICATE HOISTING CABLE. Hoists are shipped from the factory without an exterior coating of grease on hoisting cable. It is recommended, where conditions permit, that the cable be thoroughly coated at installation and kept well lubricated with LUBRIPLATE Chain and Cable Fluid or equal.

4-4. LUBRICATE UPPER SHEAVE AND LOWER BLOCK ASSEMBLY

- a. Some hoists are equipped with roller-type upper and lower sheave bearings and have grease fittings located in ends of sheave pins. If hoist is so equipped, apply (*) NLGI No. 2 grease, such as Shell Oil Company's Alvania No. 2 or equivalent, for operating temperatures from +50°F to +125°F For colder temperatures, (-20°F to +50°F) use NLGI No. 1 such as Shell Oil Company's Alvania No. 1 or its equivalent. Hoists not equipped with grease fittings in sheave pins have shielded ball bearings with lubricant sealed in and do not require additional lubrication.
- b. On Low Headroom Models, apply a few drops of S.A.E. No. 50 oil to thrust bearings at trolley brackets.

(*) National Lubricating Grease Institute.

4-5. LIMIT STOP LEVER LUBRICATION. Some hoists are equipped with a bar operated limit switch. Apply a few drops of S.A.E. No. 50 oil to pivot points of limit rod.

4-6. LUBRICATE LIMIT SWITCH. Provide a light film of NLGI No. 2 grease on bevel gear of limit switch.

SECTION V - INSPECTION AND PREVENTIVE MAINTENANCE

5-1. GENERAL. All SHAW-BOX, Series “700,” hoists are inspected and tested at the factory. Regular in service inspection and preventive maintenance programs not only help reduce overall maintenance costs but may also prevent service shutdowns by forewarning of problems that could cause these shutdowns. Regular inspections, periodic minor adjustments, regular cleaning and lubrication and replacement of worn parts can help preserve good performance and operation of your hoist.

Many factors influence the inspection and preventive maintenance program required for your hoist. Frequency and severity of service and material handled, local environmental conditions and various applicable codes are some of the factors that the user must consider to adjust inspection and maintenance program outlined in this section to meet his specific conditions.

The inspection and maintenance services outlined in this section are considered minimum. Recommended in the schedule are minimum inspection and maintenance intervals based on average daily use in a normal environment. Average daily use is based on 1000 operational hours per year maximum and intermittent operation of the hoist eight hours per day, five days per week with a maximum 40 percent “on” time and the average loading not exceeding 65 percent of rated load.

Environmental conditions in which the hoist operates are also important considerations for the user when adjusting hoist inspection and maintenance programs to local conditions. Frequency of inspection and maintenance must be increased if hoist is subjected to severe atmospheric environmental conditions, such as corrosive vapors, extreme heat or cold, cement or dust and other airborne contaminants. The user should carefully consider all environmental conditions and adjust frequency and degree of maintenance for his local conditions. Consult Lift-Tech Field Service Department for advice for unusual environmental conditions.

Various codes also regulate inspection and maintenance programs. Attention must be given to applicable federal standards, OSHA regulations, national standards, state and local codes which may include mandatory rules relating to hoist inspection and maintenance. The user should become familiar with all applicable codes for his area and be guided accordingly.

Listed on the Recommended Inspection and Maintenance Schedule are inspection frequencies and requirements. Perform these inspections regularly as scheduled and additional inspections as may be required for activity, service and environment of your hoist. The hoist operator must be responsible for determining the operating conditions and severity of service.

Inspection Schedule and Maintenance Report Form.

Shown on page 11 of this manual is a recommended Inspection Schedule and Maintenance Report form which lists various components of the hoist. The form also includes trolley

components, runway components, and miscellaneous items. This form is suggested as a guide for written inspection reports. Inspections are recommended each month and should be performed thoroughly enough to inform the hoist user of deficiencies for any item listed. This form does not supersede the Inspection and Maintenance Schedule listed below but may be used to record scheduled inspection and maintenance services required.

The user should revise the inspection interval, add additional units or provide a similar form to suit particular conditions which may exist. However, written, dated and signed inspection reports should be maintained particularly on critical items, such as hoist hooks, hoisting ropes, sheaves, drums and brakes. Periodic review of old inspection reports can point out service life of hoist components, forecasting need for adjustment, repair or replacement of these components.

As a matter of expedience, appointed maintenance personnel inspecting hoist can also take care of minor adjustments, repairs and cleaning, where required. Note column on Inspection Schedule and Maintenance Report form headed Corrective Action and Notes. When corrective action is made during inspection, note condition of part or unit as inspected in appropriate Condition column with a check mark (✓). Note “during inspection” corrective action taken and date in space provided. In this manner, items requiring further attention will be checked (✓) without showing corrective action. This will advise the designated person responsible for hoist operation and safety, who reviews the reports, that deficiencies exist. The designated person will check all deficiencies as listed and reexamine or otherwise determine whether they constitute a safety hazard.

WARNING

Deficiencies may be hazardous to personnel and equipment. Do not operate a hoist having deficiencies unless a designated qualified person has determined that these deficiencies DO NOT constitute a safety hazard.

Written, dated and signed inspection reports for many items are mandatory under OSHA regulations, and many state safety codes. It is strongly recommended that the Inspection Schedule and Maintenance Report, shown herein, be completed by a qualified person designated with the responsibility for hoist operation and safety or an inspector appointed by this person.

Inspection records can point out the service life of hoist components and help forecast the need for adjustments, repairs and ordering of replacement parts. File and review these reports after each inspection.

WARNING

Do not operate a hoist having unusual vibrations, sounds or with anything wrong or apparently wrong. Danger may be present that the hoist operator cannot see. Determine and correct cause of unusual conditions and make certain hoist can be operated safely.

5-2. INSPECT LOWER BLOCK.

- a. Check lubrication of all parts. Also lubricate the shank of the hook which passes through the crosshead. If thrust bearing is removed, apply NLGI No. 2 grease.
- b. Check each sheave to insure rope groove is smooth and free from burrs, or other surface defects.
- c. Check each sheave for freedom of rotation, replace bearings if defective.
- d. Make certain that dowel pin holding the hook nut to the hook, is securely in position.
- e. If hook is equipped with a safety latch or rotational lock, check to determine that they are in good operating condition.
- f. Check throat opening of hook. (Refer to Figure 5-1.) It is recommended that upon receipt of the hoist, a measurement be made and recorded of the hook throat opening. OSHA regulations require that the hook be replaced if the throat opening exceeds 15 percent of the original opening, or if the hook is twisted more than 10 degrees from the unbent plane. A gage block, properly identified to the hoist, similar to the one shown in Figure 5-1 is suggested to be made for each hook for use in these measurements.
- g. Hooks showing signs of cracks must be replaced. Hooks should be inspected at least once per year using dye penetrants, magnetic particle or other suitable crack detecting methods.
- h. Check wear of the hook, especially at the saddle and replace if badly worn.

5-3. INSPECT UPPER BLOCK AND HOIST SUSPENSION.

- a. Check upper block sheaves (when hoist is so equipped) for wear, damage and freedom of rotation.

If sheaves do not rotate freely, disassemble block and inspect bearings. Replace worn or damaged bearings, washers, pins or sheaves.

- b. Make certain that all sheaves, bearings and hanger pins are free of foreign material and properly lubricated. Bearings without grease fittings are lubricated for the life of the bearing and require no further lubrication. After inspection lubricate all upper block lubrication fittings.
- c. Make certain that rope guide is not bent, loose or otherwise distorted; guide must have close clearance to sheave flange to keep rope in sheave grooves.
- d. Check hoist suspension bolts on lug suspended hoists; make certain that bolts are secure, properly tightened and free from damage.
- e. Check hoist suspension bolts on trolley mounted hoists. Make certain that bolts are secure, properly tightened and free from damage. On low headroom hoists, and other two trolley hoists, suspension bolts to both trolleys must be inspected.

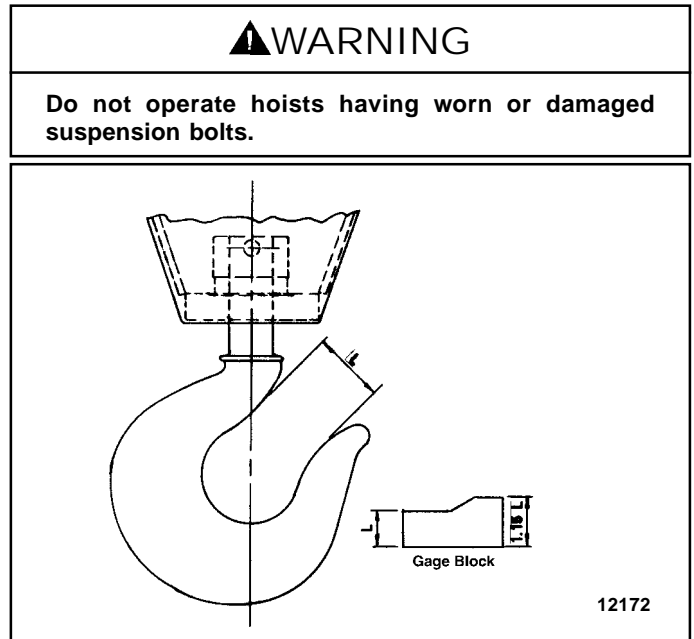

Figure 5-1. Method of measuring hook throat opening

RECOMMENDED INSPECTION AND MAINTENANCE SCHEDULE	
TIME INTERVAL	INSPECTION OR MAINTENANCE
Daily or start of each shift (visual)	* Check operation of all functional mechanisms including limit switch operation, brakes and control. Check hoist cable for kinks, abrasions, corrosion or broken wires or evidence of improper spooling on drum. Inspect hooks, upper and lower blocks, and all load bearing components for damage.
1 Month	* HOIST CABLE - Inspect and lubricate per Paragraph 5-8.
1-3 Months	* ELECTRICAL CONTROLS - Inspect per Paragraph 5-4. Check hoist gearcase oil level - add oil as required per Paragraph 4-2.d.
6 Months	* LOWER BLOCK - Inspect per Paragraph 5-2. UPPER BLOCK - Inspect per Paragraph 5-3.
Annually	* Motor brake and actuating mechanisms. Inspect and adjust per Paragraph 5-5. Inspect hooks with crack detecting procedures per Paragraph 5-2. Drain and refill hoist gearcase per Paragraph 4-2.
6 Months or 500-750 hours "on" time	* Inspect electrical controls per Paragraph 5-4. Change hoist gearcase oil - Fill with oil per Paragraph 4-2.d. Lubricate hoist cable per Paragraph 4-3. Lubricate upper and lower hook block per Paragraph 4-4. Lubricate limit stop lever per Paragraph 4-5. If a screw type limit switch is furnished, add a light film of NLGI No. 2 grease to bevel gear.
5 Years elapsed time or 5000 hours "on" time	* Complete inspection, disassembly, and maintenance required. It is recommended that your SHAW-BOX Repair Station be contacted for this service.

5-4. INSPECT ELECTRICAL CONTROLS. Arrangement of electrical control equipment varies with the type of control, physical space and the optional control features ordered with the hoist.

Note the location in the electrical compartment of the control circuit fuse, transformer, limit stop switches and the hoist contactors. Trolley contactors and optional hoist and trolley fuses may also be located in this compartment on certain models. (Note: The rope anchor on single reeved hoists is accessible from this compartment.)

Hoist and trolley fuses and trolley contactors may be located in electrical compartment located on trolley on certain models. Use wiring diagram furnished with hoist to determine electrical components on your hoist; then determine component location and identity on your hoist.

⚠WARNING

Be certain that main power switch is locked in open position before opening hinged access cover on side of hoist.

- a. Open hinged access cover at side of hoist and inspect wiring and terminals. Terminals should be securely crimped to wires and insulation sound. Terminal screws should be tight.
- b. Check condition of contactor assembly, transformer, and upper limit switches.

5-5. INSPECT MOTOR BRAKE AND ACTUATING MECHANISM.

⚠WARNING

Check to be certain main power switch is locked in open position before removing brake cover.

- a. Remove one hex button head cap screw from brake cover and lift brake cover away from gearcase cover.
- b. Unplug electrical leads and loosen set screw in gearcase cover (Ref. No. 1 in Figure 9-6). Turn actuating mechanism counterclockwise, by hand or with a plumber's strap wrench, and remove from gearcase cover.
- c. Check to see that brake plunger moves freely. Inspect for evidence of overheating or other damage.
- d. Replace all worn or damaged parts. Operating spring on actuating mechanism is color coded for brake torque; when replacing spring use spring having same color code. When replacing body assembly, also replace brake operating spring.
- e. Reassemble brake and cover only if further disassembly to check friction surfaces and hub spline is not required at this time. Refer to "MOTOR BRAKE ADJUSTMENT" paragraph 7-2 for adjusting instructions. For further disassembly proceed to step "f."
- f. To check motor brake friction surfaces (Figure 5-3), drain oil from gearcase. Disconnect solenoid coil leads. Remove hex head cap screws securing gearcase cover to gearcase. Remove gearcase cover and attached motor brake actuating mechanism from gearcase.

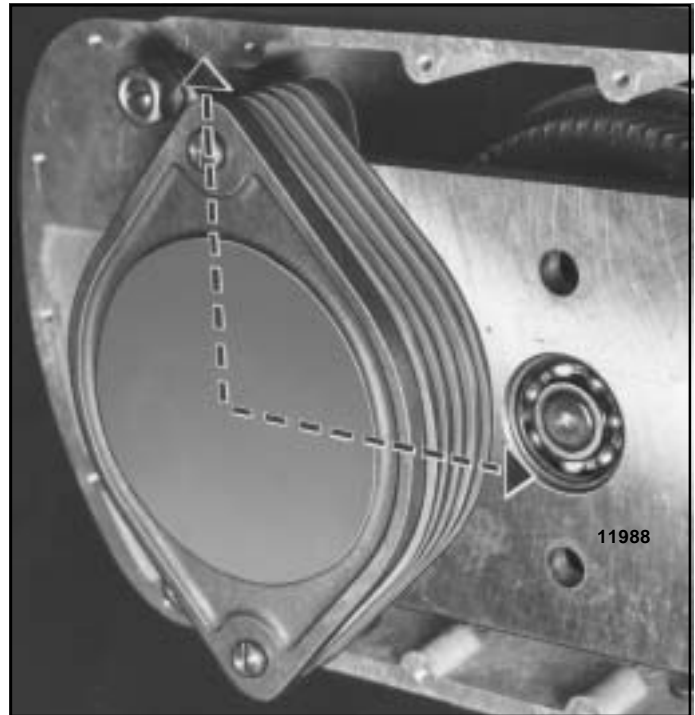

Figure 5-3. Motor Brake Friction Plates

- g. Remove retaining rings from the brake pilot studs and lift off the compression plate. Lift off washer and lining assemblies, release springs, and motor brake plates. (Note for reassembly, that two of the washer and lining assemblies have friction surfaces on one side only and must be replaced at each end. Three washer and lining assemblies, with friction surfaces on both sides and release springs are replaced between the motor brake plates; see Figure 5-3). Check motor brake plates for warping, scoring or other signs of deterioration. Also check spline fit of motor brake plates to the brake hub for gouging, mushrooming of the plates or other signs of distress or wear. Replace plates if these conditions are found. Brake plates which are replaced because of spline wear should also receive a replacement brake hub. Check condition of friction material on the washer and lining assemblies, and replace assemblies if required. Reinstall brake plates, release springs, and friction washers in sequence as shown in Figure 5-3 and replace retaining rings. On the Size 3 hoist it is possible to get the lining assemblies misoriented. When installed properly the friction linings will be on a horizontal line (not vertical). Clean and flush gearcase and replace gearcase cover using a new gasket. Refill with new lubricant.

5-6. INSPECT MECHANICAL LOAD BRAKE AND GEARING.

⚠WARNING

Check to be certain main power switch is locked in open position before removing brake cover.

- a. To inspect hoist, drain oil from gearcase, remove motor brake actuating mechanism per Paragraphs 5-5.a and 5-5.b, remove hex head cap screws from gearcase cover, and remove gearcase cover.

- b. Remove compression plate, washer and lining assemblies, springs and brake plates as described in Paragraph 5-5.g. Remove hex nuts and hex head bolts holding gearcase spider and remove spider. Inspect gearing for tooth wear or damage, (see Figure 5-4). If replacement parts are indicated, disassemble load brake and gearing as follows:

⚠ WARNING

Before disassembly prevent rope drum from free spinning by wedging drum in place with a block of wood, and resting lower block on work surface so all weight is off rope drum. Rope may also be removed from hoist drum.

- (1) Pull out motor pinion shaft from gearcase, (see Figure 5-4).
- (2) The complete load brake assembly can now be pulled out from the gearcase or removed part by part.

⚠ WARNING

The complete mechanical load brake assembly is heavy (approx. 150 lbs.). Provide adequate means to support weight of assembly before removal from gearcase, especially if brake assembly is removed with hoist suspended.

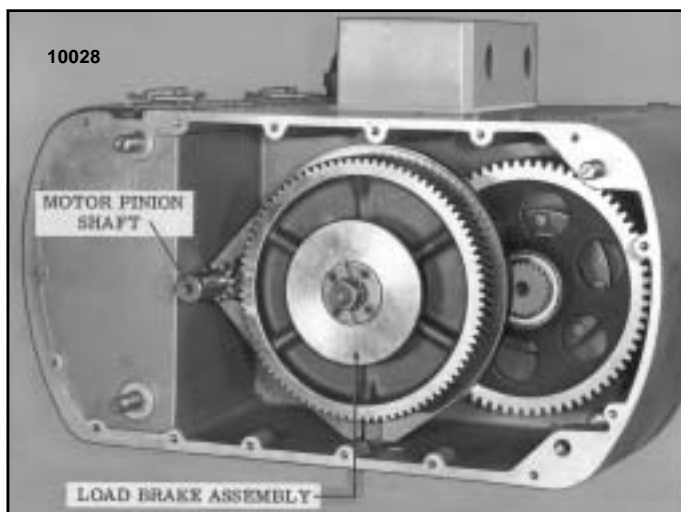

Figure 5-4. View of Gearing - Spider Removed

- c. To disassemble and inspect mechanical load brake without overload clutch, either in or removed from hoist, proceed as follows:

- (1) Remove the two (three on larger models) selflocking screws from each of two retaining plates and remove plates from groove on splines of brake shaft (Figure 5-5).

- (2) Pull off brake helix (Ref. No. 12, Figure 9-4).

- (3) Pull off brake gear (Ref. No. 11, Figure 9-4).

Note: It may be necessary to apply some force to end of shaft when removing brake gear.

- (4) Remove (1) friction washer, roller and ratchet assembly, and another friction washer. The roller and ratchet assembly should not be disassembled; replacement, if required, as an assembly is recommended.

- (5) Remove brake shaft and flange assembly.

- (6) Check condition of all parts for evidence of wear or damage. Replace worn or damaged parts.

- (7) Reinstall in reverse procedure from disassembly making certain helix is seated and that retaining plates are properly seated in groove on shaft spline (Figure 5-5).

- d. To disassemble and inspect mechanical load brake with overload clutch, either in or removed from hoist, proceed as follows:

- (1) Remove the two (three on larger models) selflocking screws from each of two retaining plates and remove plates from groove on splines of brake shaft (Figure 5-5).

- (2) Pull off brake helix. Surface of brake helix may be below brake adjusting collar (Ref. No. 24, Figure 9-4). With some pressure on end of brake shaft, pull brake gear toward end of shaft about one inch. Then return gear to original position to expose outside of helix. Grasp outside of brake helix and slide off from splined shaft.

- (3) Do not remove the overload clutch adjusting screws unless clutch requires service. See Paragraph 5-6.e below. Remove clutch and brake gear as one unit by pulling off from brake shaft while exerting some pressure on end of brake shaft.

- (4) Remove (1) friction washer, roller and ratchet assembly, then the other friction washer. The roller and ratchet assembly should not be disassembled; replacement, if required, as an assembly is recommended.

- (5) Remove brake shaft and flange assembly.

- (6) Check condition of all parts for wear or damage. Replace worn or damaged parts.

- (7) Reinstall in reverse procedure from disassembly making certain helix is seated and that retaining plates are properly seated in groove on shaft spline (Figure 5-5).

- e. Disassembly of overload clutch. It is recommended that disassembly, inspection, and reassembly of the overload clutch be performed by a factory approved SHAW-BOX Repair Station. Fine adjustments can be made with clutch installed. (See OVERLOAD CLUTCH ADJUSTMENT, Paragraph 7-5.)



Figure 5-5. Installing Retainer Plates on Load Brake Shaft

- f. To remove drum gear, remove spirolox retaining ring from end of drum shaft and pull drum gear from splined shaft (Figure 5-6). This should be done after complete load brake shaft assembly has been removed.

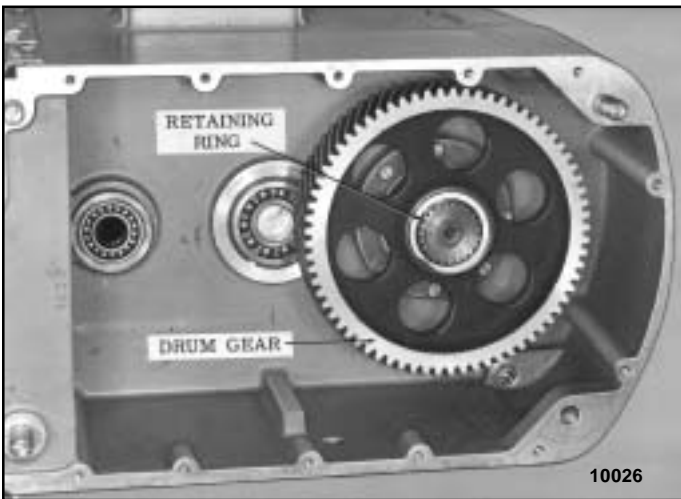

Figure 5-6. All Gearing Removed except Drum Gear

- g. Replace motor pinion shaft.
- h. Reinstall spider and motor brake plates on gearcase. Make certain motor pinion shaft bearing on a size 2 hoist and load brake shaft bearing (Figure 5-7) are installed with the external retainer firmly seated against the inside (hoist side) of the spider and retainer side of bearing toward hoist. On a size 3 hoist the motor pinion shaft bearing is caged to the spider.
- j. Replace gearcase gasket and cover and refill gearcase to bottom of oil level plug.
- k. Reconnect motor brake leads.



Figure 5-7. Installing Load Brake Shaft Ball Bearing in Gearcase Spider (Size 2 Hoist Shown)

- i. Before replacing brake cover, fine adjustment can be made to overload clutch if your hoist is so equipped. See OVERLOAD CLUTCH ADJUSTMENT - Paragraph 7-5. If clutch adjustment is not required replace brake cover.

5-7. INSPECT ROPE DRUM AND SHAFT.

- a. To remove rope drum, remove hoisting cable, gearcase cover, and remove load brake and gearing as outlined in Paragraph 5-6.
- b. Remove hinged side cover, hinge plate and cover bridge from hoist frame.
- c. Take out four bolts holding gearcase to frame and remove gearcase. Drum and shaft will remain in frame.
- d. Remove four bolts holding drum shaft bearing retainer to inside of gearcase and pull ball bearing and oil seal from bore in gearcase.
- e. Pull drum and shaft from frame.
- f. Check parts for wear and damage. Replace drum or shaft if there are any signs of cracks or other damage. Replace oil seal if the sealing edge appears worn or cracked.
- g. Reinstall parts following a procedure in reverse of disassembly. Refill gearcase to proper level with correct grade of oil. (See SECTION IV - LUBRICATION.)

5-8. ROPE INSPECTION, MAINTENANCE AND REPLACEMENT.

WARNING
<p>Wire rope improperly handled or abused can create a SAFETY HAZARD. Read and comply with Inspection, maintenance and replacement information given herein.</p>

a. Inspection. Wire rope on your hoist is one of the most important components requiring frequent inspection and maintenance. All wire ropes will eventually deteriorate to a point where they are not safe and will require replacement. Wire rope should be thoroughly inspected at regular monthly intervals by an authorized person and a determination made when further use of the rope would constitute a safety hazard. Each inspection should include a written, dated and signed report of rope condition. Reports should be filed and reviewed each month and any rope deterioration carefully noted. Inspections revealing but not limited to the following conditions, should cause inspector to question remaining strength of rope and consider replacement:

- (1) Twelve randomly distributed broken wires in one rope lay or four broken wires in one strand.
- (2) Wear of one-third of the original diameter of outside individual wires.
- (3) Kinking, crushing or birdcaging.
- (4) Heat damage from any cause.
- (5) Reductions from nominal diameter of more than
 - (a) 1/64" for 3/16", 1/4", and 5/16" diameter rope.
 - (b) 1/32" for 3/8" and 7/16" diameter rope.
 - (c) 3/64" for 9/16" diameter rope.
- (6) Rope corrosion, internal or external.
- (7) Effects from improper lubrication.
- (8) Rope idle for month or more due to shutdown.

Special attention should be exercised when inspecting rope normally hidden during inspecting procedures.

b. Maintenance. Keep rope well lubricated to help reduce internal friction and prevent corrosion. Lubricant, as described in Paragraph 4-3, should be applied as a part of the regular maintenance program. Special attention is required to lubricate sections of rope over equalizing sheaves and other hidden areas.

Avoid dragging ropes in dirt or around sharp objects which will scrape, nick, crush or induce sharp bends in the rope.

c. Replacement. When recommended by an authorized inspector, the rope should be replaced. Replacement rope assemblies are shipped from the factory carefully coiled to prevent damage by kinking. Care must be taken to avoid twisting or kinking when uncoiling and handling during reeving.

Before replacing rope, check condition of grooves in sheaves and drums to determine if they are excessively worn.

▲WARNING
Use only factory approved rope with swagged wire rope sockets.

When first using hoist after rope replacement, break in rope by operating under lighter loads to full travel before applying maximum load.

5-9. ROPE REEVING.

a. General. Before unreeling rope from a coil or reel be sure floor is clean. Dirt picked up by the rope can cause excessive wear and abrasion. Uncoil the rope by rolling the coil or reel along the floor; or, place reel on stand with shaft thru center of reel so rope can be pulled straight out with reel rotating.

▲CAUTION
It is imperative that rope reel or coil rotate as rope unwinds. If coil or reel does not rotate the wire will be twisted as it is uncoiled and kinking will result. A kinked rope may be damaged and unsafe for maximum service.

Before removing the old rope, refer to reeving diagrams, Figure 5-8. Face the rope drum on your hoist from the side which the rope comes off drum. To assist with reeving your hoist, select the reeving diagram for your hoist. Note the description (such as 3 part double reeved, Figure 5-8, ④) and refer to paragraph below with the same description which describes reeving procedure.

b. Removing old rope - for all reevings.

- (1) Lower the bottom block to a scaffold located 6 to 7 feet below hoist to relieve tension on wire rope. (Bottom block may be lowered to floor if desired; however, to handle less weight and for ease of reeving adequate scaffold below the hoist is recommended.)
- (2) Remove bottom block sheave guard.
- (3) Remove key plates from both sides of sheave pin and slide sheave pin from bottom block.
- (4) Lift out sheaves from the top of the bottom block and remove wire rope.
- (5) Remove key plates or snap rings from upper block sheave(s) and slide out upper block sheave pins, releasing upper block sheaves. Remove wire rope from sheaves.
- (6) Make certain all personnel are clear of hoist and operate hoist "DOWN" to completely unwind all wire rope from drum. Stop hoist so drum anchor slot(s) is accessible. Remove live rope end socket(s) from drum.
- (7) TURN OFF POWER TO HOIST.
- (8) Open electrical compartment cover on single reeved hoists to remove dead end socket.

Remove cotter pin from socket, slide rope toward socket until rope end fitting clears socket. Lift out rope and end fitting through groove provided. Remove old rope. Close electrical compartment cover.

c. Installing new rope.

▲WARNING
Winding rope on rope drums with power can be hazardous. Keep hands safe distance from drum, wear gloves and use extreme care when winding rope.

SINGLE REEVED HOISTS

Stretch new cable on floor in one continuous length. Make certain there is no twist in rope.

- (1) Place one end of rope in rope drum anchor slot. Be sure end fitting is properly seated.
- (2) With all personnel clear of hoist - TURN ON POWER.
- (3) Operate hoist "UP;" guiding new rope into drum grooves with gloved hand, until the following lengths remain unwound:
 - (a) 2 part single reeved - about 14'-0"
 - (b) 4 part single reeved - about 28'-0"
 - (c) 6 part single reeved - about 42'-0"
 - (d) 8 part single reeved - about 56'-0".
- (4) Proceed with reeving as described in appropriate paragraph below and the reeving diagram for your hoist.

DOUBLE REEVED HOISTS

Stretch new cable on floor in one continuous length. Make certain there are no twists in rope.

- (1) Pull far end of rope toward end of rope nearest hoist, until both ends are even and a loop is formed. Place fittings on both ends of rope in anchor slots on rope drum. Be sure end fittings are properly seated.
- (2) With all personnel clear of hoist - TURN ON POWER.
- (3) Operate hoist "UP;" guiding rope into grooves at both ends of drum, until the distance from the drum to the loop is:
 - (a) 2 part double reeved - about 14'-0"
 - (b) 3 part double reeved - about 21'-0"
 - (c) 4 part double reeved - about 28'-0"
 - (d) 5 part double reeved - about 35'-0"
 - (e) 6 part double reeved - about 42'-0".
- (4) Proceed with reeving as described in appropriate paragraph below and the reeving diagram for your hoist.

d. Reeving - 2 part single.

See Figure 5-8, ⑩ for diagram.

See Figure 9-14 for bottom block parts with 3/8" or 7/16" rope.

See Figure 9-15 for bottom block parts with 9/16" rope.

With new rope installed on drum as described in Paragraph 5-9.c, single reeved above, proceed with rereeving following steps below:

- (1) Thread the remaining cable end through limit switch weight, then pass it over partial sheave, inside hoist, and insert in anchor fitting at hoist frame. Be certain power is off before opening electrical compartment cover for access to anchor fitting. Properly seat rope end fitting in socket and replace cotter pin in end of socket.

- (2) Grasp loop, formed after installing end anchor, and place bottom block sheave in loop. Lower sheave into bottom block and insert sheave pin. Replace key plates and bolts holding sheave pin in place.

- (3) Replace sheave guard. Make certain rope is not twisted. Should the two parts of rope tend to wind around each other, remove cable from anchor slot and untwist cable. Reattach the cable anchor.

- (4) Lubricate cable per Paragraph 4-3.

e. Reeving - 4 part single.

See Figure 5-8, ⑪ for diagram.

See Figure 9-14 for bottom block parts with 1/4", 5/16", 3/8", 7/16" rope.

See Figure 9-15 for bottom block parts with 9/16" rope.

With new cable installed on drum as described in Paragraph 5-9.c, single reeved above, proceed with rereeving following steps below:

- (1) Grasp the cable near the middle (about 14'-0") of the unwound end and form a loop. Place upper sheave in this loop. Slide upper sheave with cable into sheave pocket.

- (2) Insert sheave pin into sheave. Replace key plates and bolts to hold sheave pin in place.

- (3) Thread rope end socket through limit switch weight; then, pass it over partial sheave, inside hoist, and insert in anchor fitting at hoist frame. Be certain power is off before opening electrical compartment cover for access to anchor fitting. With end fitting properly seated in anchor, replace cotter pin in end of socket. Two loops have now been formed for bottom block sheaves.

- (4) Place one sheave in each loop. Install one sheave with cable in bottom block; partially insert sheave pin to hold sheave in place. **Note:** Some blocks have spacer washers between sheaves. Be certain to install spacer washers between sheaves, when shown on parts illustration. Install second sheave with cable into bottom block. Slide sheave pin through sheave. Replace key plates and bolts securing sheave pin.

- (5) Replace sheave guard.

- (6) Lubricate cable per Paragraph 4-3.

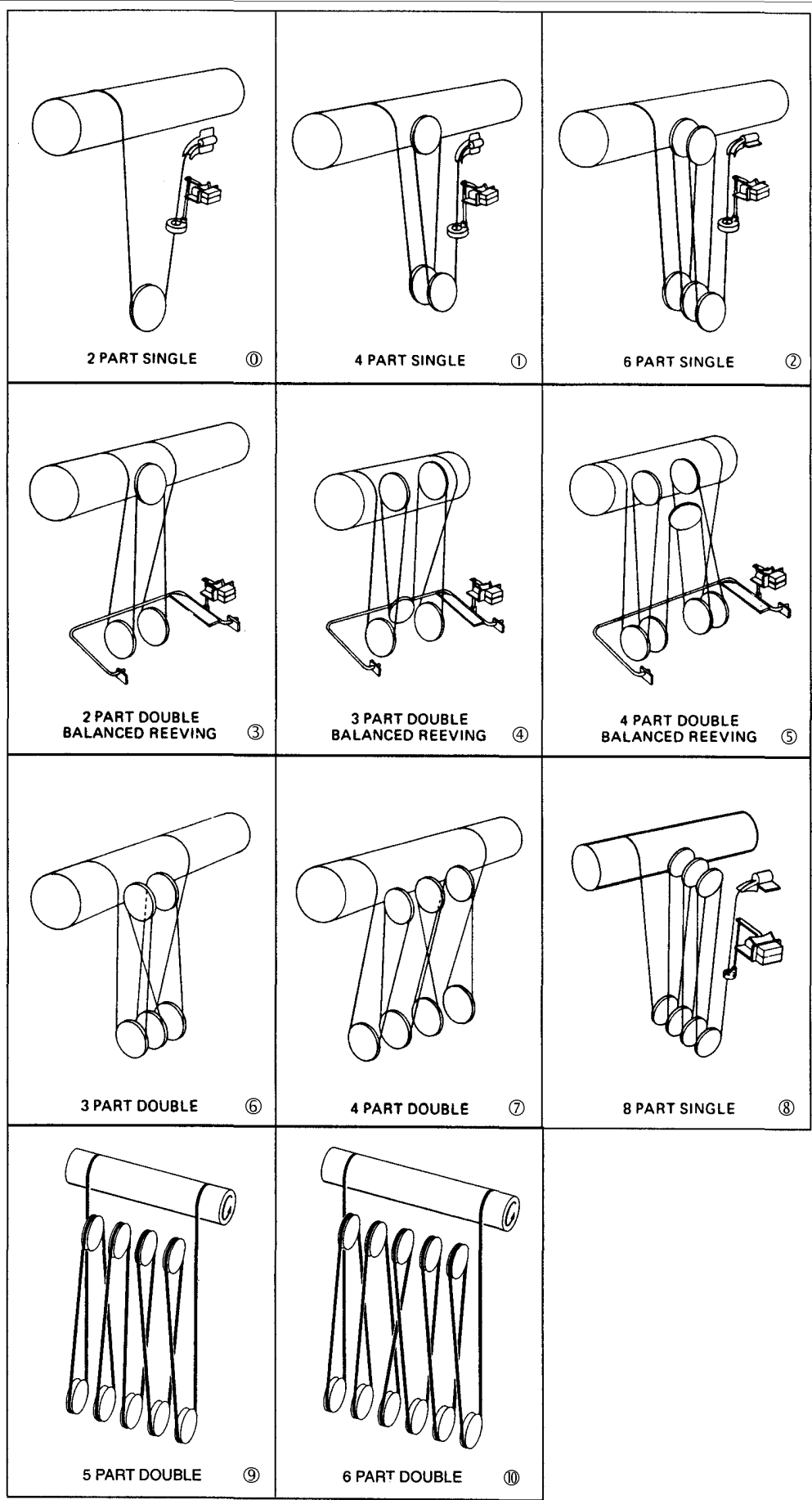

Figure 5-8. Reeving Diagrams

f. Reeving - 6 part single.

See Figure 5-8, ② for diagram.

See Figure 9-15 for bottom block parts - 9/16" rope.

See Figure 9-19 for bottom block parts - 3/8" rope.

With new cable installed on drum as described in Paragraph 5-9.c, single reeved above, proceed with rereiving following steps below:

- (1) Grasp cable at a point one-third (approx. 14'0") the distance hanging below the rope drum and form a loop. Place one upper sheave in this loop. Slide upper sheave with cable into sheave pocket; partially insert sheave pin to hold sheave in place.
- (2) Repeat (1) above and install second upper sheave with rope. Insert sheave pin and install key plates and bolts to secure sheave pin.
- (3) Thread rope end socket through limit switch weight; then, pass it over partial sheave, inside hoist, and insert in anchor fitting at hoist frame. Be certain power is off before opening electrical compartment cover for access to anchor fitting. With end fitting properly seated in anchor, replace cotter pin in end of socket. Three loops have now been formed for bottom block sheaves.
- (4) Place sheave in each loop. Install one sheave with cable in bottom block; partially insert sheave pin to hold sheave in place. Note: Be certain to install spacer washers between sheaves, when shown on parts illustration.
- (5) Repeat step 4 for remaining bottom block sheaves. Install sheave pin through sheaves. Replace key plates and bolts securing sheave pin.
- (6) Replace sheave guard.
- (7) Lubricate cable per Paragraph 4-3.

g. Reeving - 2 part double.

See Figure 5-8, ③ for diagram.

See Figure 9-16 for block parts.

With new rope installed on drum as described in Paragraph 5-9.c, double reeved above, proceed with rereiving following steps below:

- (1) Form loops in the two ropes coming from rope drum. Place these loops into bottom block pockets and slide pipe or rod through sheave pin holes. Note position of ropes passing limit stop bar.
- (2) Partially insert upper block sheave pin in opening and install one spacer washer. Raise remaining rope up to hoist, form a loop and place upper sheave in this loop.
- (3) Place sheave with rope into upper sheave pocket and slide pin partially thru sheave. Install remaining washer and push pin thru side plates. Install snap ring on each end of pin to secure pin in place.
- (4) Insert lower sheave pin into bottom block removing pipe as sheave pin is inserted. Be certain washers are replaced as shown on parts illustration. With sheave pin installed, replace key plates and bolts to secure sheave pin.

- (5) Replace sheave guard.

- (6) Lubricate rope per Paragraph 4-3.

h. Reeving - 3 part double.

See Figure 5-8, ④ for diagram.

See Figure 9-17, for block parts.

With new rope installed on rope drum as described in Paragraph 5-9.c, double reeved above, proceed with rereiving following steps below:

- (1) Form loops in the two ropes coming from rope drum. Place these loops into bottom block pockets and slide pipe or rod through sheave pin holes. Note position of ropes passing limit stop bar.
- (2) Grasp remaining rope at midpoint loop and raise two rope parts up to the hoist. Carefully form two upper sheave loops and insert into upper sheave pockets. Slide pipe or rod through sheave pin holes to hold the two ropes.
- (3) Pull remaining rope down to the lower block equalizer sheave. Place equalizer sheave in loop and sheave with rope in sheave pocket. Insert sheave pin thru one washer, the sheave and the other washer.
- (4) Push sheave pin thru side plates and install snap ring on each end of pin to secure pin.
- (5) Insert lower sheave pin into bottom block thru washers and sheaves as shown on parts illustration, removing pipe as sheave pin is inserted.
- (6) Install key plates and bolts to secure pin.
- (7) Repeat steps 5 & 6 for upper block sheaves.
- (8) Replace sheave guard.
- (9) Lubricate rope per Paragraph 4-3.

j. Reeving - 4 part double.

See Figure 5-8, ⑤ for diagram.

See Figure 9-18, for block parts.

With new rope installed on rope drum as described in Paragraph 5-9.c, double reeved above, proceed with rereiving following steps below:

- (1) Form loop in each rope coming from rope drum. Place these loops into outside sheave pockets in bottom block. Note position of ropes passing limit stop bar. Slide pipe or rod thru sheave pin holes to hold the two ropes.
- (2) Grasp remaining rope at midpoint loop and raise loop with two ropes up to the hoist. Carefully form two upper sheave loops and insert sheaves with rope into upper sheave pockets. Slide pipe thru upper sheave pin holes to hold the two ropes.
- (3) Pull loop and two ropes down to the bottom block. Pass ropes across bottom block between ropes placed there in step 1. Note position of ropes passing limit stop bar.
- (4) Carefully remove pipe while holding first two ropes in bottom block and insert ropes in step 3 into outside block pockets between existing ropes.

- (5) Pull remaining rope up to upper equalizer sheave. Partially insert sheave pin thru yoke side plate and one washer. Place sheave in rope loop and insert sheave with rope into sheave pocket. Slide pin thru sheave and remaining washer into opposite side plate. Secure pin by installing snap ring on each side of pin.
- (6) Insert upper block sheave pin thru side plate and one washer. Place upper block sheaves in rope loop and insert into sheave pocket removing pipe or rod as pin is inserted. Make certain to install one washer on each side of upper sheaves.
- (7) Install key plates and bolts to secure pin.
- (8) Partially insert lower block sheave pin into block side plate opening and thru one washer removing pipe as pin is inserted. Place outside sheave into rope loop and insert sheave with rope into sheave pocket. Slide pin into sheave. Repeat this procedure installing sheaves and washers in both outside pockets of bottom block. Center pocket of bottom block is not used for sheaves.
- (9) Replace key plates and bolts to secure sheave pin.
- (10) Lubricate rope per Paragraph 4-3.

k. Reeving - 3 part double.

See Figure 5-8, ⑥ for diagram.

See Figure 9-15, for block parts.

With new rope installed on rope drum as described in Paragraph 5-9.c, double reeved above, proceed with rereeving following steps below:

- (1) Form loops in the two ropes coming from rope drums. Place these loops into bottom block pockets and slide pipe or rod through sheave pin holes.
- (2) Grasp remaining rope at midpoint loop and raise loop and two ropes up to the hoist. Carefully form two upper sheave loops and insert into upper sheave pockets. Slide pipe or rod through sheave pin holes to hold the two ropes.
- (3) Pull the remaining rope down to the lower block. Insert loop in between the two ropes already in lower block by partially removing pipe while holding original ropes in place. **Note:** This last loop must be rotated 90° as it is placed between existing ropes into lower block; refer to reeving diagram.
- (4) Complete installation following steps 4 thru 9 in Paragraph 5-9.h.

l. Reeving - 4 part double.

See Figure 5-8, ⑦ for diagram.

See Figure 9-15, for block parts.

With new rope installed on rope drum as described in Paragraph 5-9.c, double reeved above, proceed with rereeving following steps below:

- (1) Form loop in each rope coming from rope drum. Place these loops in sheave pockets in bottom block. Slide pipe or rod thru sheave pin holes to hold the two ropes.
- (2) Grasp remaining rope at midpoint loop and raise loop with two ropes up to the hoist. Carefully form two upper sheave loops and insert into upper sheave pockets. Slide pipe or rod thru upper sheave pin holes to hold the two ropes.
- (3) Pull loop and two ropes down to the bottom block. Pass ropes across bottom block between ropes placed there in step 1.
- (4) Carefully remove pipe while holding first two ropes in bottom block and insert second pair (step 3) of ropes in bottom block between existing ropes.
- (5) Pull remaining rope up to upper equalizer sheave (center sheave). Remove pipe while holding first two ropes in place far enough to insert last loop. Note: This last loop must be rotated 90° as it is placed between existing ropes into upper block. Refer to reeving diagram.
- (6) Complete installation following steps 6 thru 10 in Paragraph 5-9.j.

m. Reeving - 8 part single.

See Figure 5-8, ⑧ for diagram.

See Figure 9-21, for block parts.

With new rope installed on drum as described in Paragraph 5-9.c, single reeved above, proceed with rereeving following steps below:

- (1) Grasp cable at a point one-fourth (approx. 14'-0") the distance hanging below the rope drum and form a loop. Place one upper sheave in this loop. Slide upper sheave with cable into sheave pocket; partially insert sheave pin to hold sheave in place.
- (2) Repeat (1) above and install second upper sheave with rope.
- (3) Repeat (1) above and install third upper sheave with rope. Insert sheave pin and install key plates and bolts to secure sheave pin.
- (4) Thread rope end socket through limit switch weight; then, pass it over partial sheave, inside hoist, and insert in anchor fitting at hoist frame. Be certain power is off before opening electrical compartment cover for access to anchor fitting. With end fitting properly seated in anchor, replace cotter pin in end of socket. Four loops have now been formed for bottom block sheaves.
- (5) Place sheave in each loop. Install one sheave with cable in bottom block; partially insert sheave pin to hold sheave in place. Note: Be certain to install spacer washers between sheaves, when shown on parts illustration.

- (6) Repeat step 5 for remaining bottom block sheaves. Install sheave pin through sheaves. Replace key plates and bolts securing sheave pin.
- (7) Replace sheave guard.
- (8) Lubricate cable per Paragraph 4-3.

n. Reeving - 5 part double.

See Figure 5-8, ⑨ for diagram.
See Figure 9-20a, for block parts.
Reeve similar to Paragraph 5-9.1.

o. Reeving - 6 part double.

See Figure 5-8, ⑩ for diagram.
See Figure 9-22, for block parts.
Reeve similar to Paragraph 5-9.1.

p. Checking for and removal of rope twisting.

Although rereaving of hoist may have been done carefully, sometimes after new rope has been installed twisting may occur. With new rope installed, the hoist block should be raised and lowered several times with gradually increasing loads through full lift. If the block still rotates excessively at no load, the rope may have twists which should be removed.

- (1) To remove rope twist in single reeved hoists.
 - (a) Observe direction block tends to rotate.
 - (b) Lower the block to a low position and turn off power.
 - (c) Rotate rope near the anchor end several turns in a direction tending to correct block rotation. This rotates rope end fitting in the anchor.
 - (d) Turn on power; raise and lower the block several times to feed the correcting twist in the rope through the reeving.
 - (e) If block still tends to twist repeat the above procedure until block rotation is corrected.
- (2) To remove rope twist in double reeved hoists.
 - (a) Observe direction block tends to rotate.

- (b) Lower the bottom block unspooling rope from rope drum until only one quarter (1/4) turn remains to rope end anchors in drum.
- (c) Rotate rope near ends entering drum in a direction tending to correct block rotation. This rotates rope end fittings in the drum.
- (d) Turn on power; raise and lower the block several times to feed the correcting twist in the rope through the reeving.
- (e) If block still tends to twist repeat the above procedure until block rotation is corrected.

5-10. TESTING HOIST.

- a. General. Before placing hoist in service, hoist should be tested to insure safe operation when hoist has been disassembled and reassembled. To test, suspend hoist from an overhead supporting member of sufficient strength to support the weight of the hoist and the rated load. Hoists having overload clutches require an overhead supporting structure capable of supporting with appropriate safety factor a load equal to 175 percent rated load and the weight of the hoist - see OVERLOAD CLUTCH ADJUSTMENT - Paragraph 7-5. Connect hoist to power supply as shown on hoist nameplate and perform the checks listed in b and c below:
 - b. Check hoist as outlined in PRE-OPERATION CHECKS, SECTION II, Paragraph 2-4.
 - c. Check hoist with rated load.
 - (1) Attach rated load to lower hook
 - (2) Depress "UP" push button and raise load. When push button is released, hoist should immediately stop and hold load at that level.
 - (3) Depress "DOWN" push button, lower load a short distance and release button. Hoist should stop immediately and hold load at that level.

Note:

If load drifts downward slowly in step 2 or 3 above, motor brake requires adjustment - see MOTOR BRAKE ADJUSTMENT - SECTION VII - Paragraph 7-2.

SECTION VI - TROUBLE SHOOTING

Trouble	Probable Cause	Possible Remedy
6-1. Hoist Will Not Operate.	a. No power to hoist. b. Wrong voltage or frequency c. Loose or broken wire connections in hoist electrical system.	a. Check switches, circuit breakers or fuses and connections in power supply lines. b. Check current rating on motor data plate against power supply. c. Shut off power supply, open hinged cover on hoist and check wiring connections. Also check connections in push button station and limit switches.

SECTION VI - TROUBLE SHOOTING (continued)

Trouble	Probable Cause	Possible Remedy
6-1. Hoist Will Not Operate (Continued).	<p>d. Contactor assembly not functioning.</p> <p>e. No control voltage.</p> <p>f. Motor burned out.</p>	<p>d. Check contact points. Replace if excessively burned or pitted. Check for burned out contactor coils. See that necessary jumper wires are properly installed.</p> <p>e. Check transformer fuse. If blown, check for grounding and/or shorts in the push button station. Check the transformer coil for signs of overheating. Replace transformer if burned out. Verify the transformer secondary is the same voltage as the coils to which it is connected.</p> <p>f. Replace motor. Check input power supply. Check hoist motor connections.</p>
6-2. Hook Moves in Wrong Direction.	<p>a. Reverse phasing on three-phase hoists.</p> <p>b. Hoist or push button wired wrong.</p>	<p>a. Interchange any two power supply line leads. Refer to SECTION II.</p> <p>b. Check wiring connections with appropriate wiring diagram.</p>
6-3. Hook Will Raise But Not Lower.	<p>a. Lower electrical circuit open.</p> <p>b. Contactor not functioning.</p>	<p>a. Check for loose connections. See that necessary jumper wires are properly installed on contactor.</p> <p>b. Check for burned or pitted contact points or burned out contactor coil.</p>
6-4. Hook Will Lower But Not Raise.	<p>a. Excessive load.</p> <p>b. Hoist circuit open.</p> <p>c. Contactor not functioning.</p>	<p>a. Reduce loading to rated load of hoist, as shown on nameplate.</p> <p>b. Check for loose connections. See that necessary jumper wires are properly installed on contactor.</p> <p>c. Check for burned or pitted contact points or burned out contactor coil.</p>
6-5. Hoist Will Not Lift Rated Load.	<p>a. Low voltage</p> <p>b. Overload Clutch not properly adjusted.</p>	<p>a. See that power supply current is same voltage listed on motor data plate. Check size of power supply lines.</p> <p>b. See SECTION VII, Paragraph 7-5.</p>
6-6. Load Drifts Excessively When Hoist Is Stopped.	<p>a. Excessive load.</p> <p>b. Motor brake not holding.</p> <p>c. Load brake not holding.</p>	<p>a. Reduce loading to rated load, as shown on nameplate.</p> <p>b. With No Load, check hoist for drift. If drifting is excessive, inspect motor brake (SECTION V, paragraph 5-5) and adjust as outlined in SECTION VII, Paragraph 7-2.</p> <p>c. (1) After determining that the motor brake is working properly, attach rated load to hook and operate hoist. If the load accelerates during lowering, the load brake is not functioning properly. See Section V, paragraph 5-6 for replacing worn or damaged parts.</p> <p>(2) If load brake checks O.K., magnetic motor brake needs adjustment (see b above).</p>

SECTION VI - TROUBLE SHOOTING (continued)

Trouble	Probable Cause	Possible Remedy
6-7. Hoist Motor Overheats	<ul style="list-style-type: none"> a. Excessive load. b. Excessive duty-cycle c. Wrong voltage or frequency. d. Defective motor or worn bearings in hoist frame. e. Overload clutch slipping without lifting load. f. Motor brake actuating mechanism sticking. 	<ul style="list-style-type: none"> a. Reduce loading to rated load of hoist, shown on nameplate. b. Reduce frequency of lifts or amount of jogging. c. Check current rating on motor data plate against power supply. d. Disassemble hoist and inspect for defective, worn or damaged parts. e. Adjust clutch per SECTION VII, Paragraph 7-5. f. (1) Disassemble actuating mechanism and inspect for defective work or damaged parts. (2) Check voltage to brake coil at brake controller. Brake control with solenoid connected provides a 100 volt DC pulse to the solenoid for 1 /10 of a second, after which time this voltage drops to 10 volts DC \pm 5 volts.
6-8. Hoist Operates Intermittently.	<ul style="list-style-type: none"> a. Collectors make poor contact. b. Loose connections. 	<ul style="list-style-type: none"> a. Check collectors for free movement of spring arm, weak spring or electrical connections. b. Check all wiring for loose connections.

SECTION VII - ADJUSTMENTS

7-1. MECHANICAL LOAD BRAKE. The mechanical load brake on SHAW-BOX hoists is a roller ratchet "Weston" type automatic brake. The brake is not adjustable and requires only periodic inspection and occasional replacement of the friction washers.

7-2. MOTOR BRAKE ADJUSTMENT. These brakes are designed so that adjustment is seldom required. If, after a period of service, the load hooks "drifts" downward more than usual for your hoist before coming to a stop, the motor brake may require adjustment to compensate for brake disc wear.

In addition to the adjustment instructions below motor brake adjustment instructions may also be found inside the brake cover. Refer to Figure 9-6 and proceed as follows:

- a. Remove one hex socket button head cap screw from brake cover and then remove brake cover.
- b. Loosen set screw at gearcase cover (Ref. No. 1 in Figure 9-6).
- c. Turn brake actuating assembly, by hand, until brake adjustment indicator pin (Ref. No. 10) is flush with the end of the body assembly (Ref. No. 9).
- d. Retighten set screw.

Note: Do not overtighten set screw. Damage to actuator or gearcase cover threads may occur.

- e. Replace brake cover.

f. Operate hoist and brake to assure brake is free when disengaged. If brake is dragging, loosen brake actuating assembly by 1/8 turns until brake action is proper.

g. If, after above adjustment, the load hook continues to "drift" downward more than normal for this hoist, make a complete inspection of motor brake mechanism including friction surfaces. See SECTION V, Paragraph 5-5.

7-3. BLOCK OPERATED LIMIT SWITCH. The block operated limit stop, furnished as standard equipment, is nonadjustable and designed to stop lower block at safest high point of travel to eliminate any possibility of doubleblocking. When the safest high point is reached, the limit switch automatically stops hook travel.

WARNING

Some hoists are shipped with the electrical controls loose (disconnected) and will not have the upper and lower limit switches connected. DO NOT OPERATE HOIST UNTIL LIMIT SWITCHES ARE PROPERLY CONNECTED AND ADJUSTED. Failure to do so may allow hoist to be operated beyond proper travel limits which can cause load to drop, resulting in damage to equipment or injury.

7-4. GEARED ROTARY LIMIT SWITCH ADJUSTMENT.

The geared rotary type limit switch is optional equipment and when furnished is located at the motor end of the hoist.

- a. This limit switch consists of two adjustable cams driven thru gear reduction by a worm gear shaft which flexibly couples to end of drum shaft. Each cam operates the contacts of separate switches; one for hoisting circuit and one for lowering circuit. The switch assembly must be wired in accordance with appropriate wiring diagram which is shipped with the hoist. Adjustment of the rotary limit switch is accomplished as follows: (Refer to Figure 7-1.)

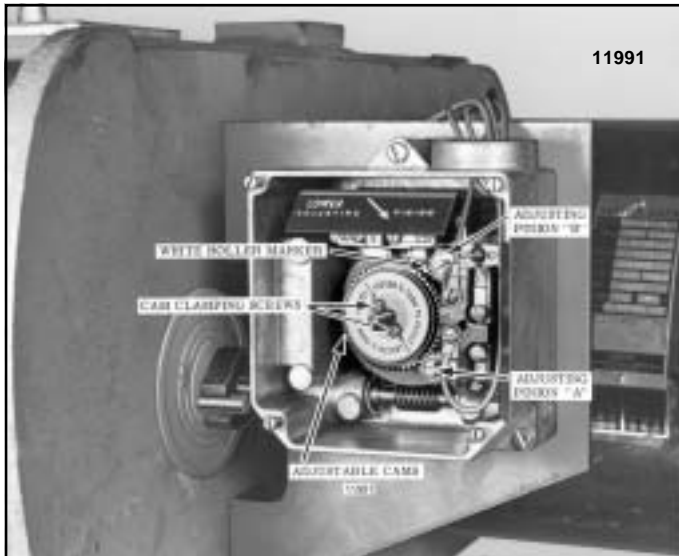

Figure 7-1. Geared Rotary Limit Switch Adjustment (Early Model Hoists)

- (1) Remove four cover screws and lift off enclosure cover.
- (2) Operate hoist to raise lower block to upper limit of desired travel. Allow about 2" for drift.
- (3) Loosen the two cam clamping screws on top of cam assembly one half turn each.
- (4) Locate cam adjusting pinion "A" (upper) by referring to the indicating arrow on insulation shield. Depress this screw with a screwdriver until pinion teeth mesh with gear teeth on top cam. Rotate cam in direction cam turns when hoisting by turning screwdriver until cam operates switch. White marker on gear teeth is directly over nylon roller that trips switch. When top operating cam has been adjusted so the roller has tripped switch, adjustment of upper limit is complete.
- (5) Operate hoist and run lower block to lower limit of desired travel. Allow approximately 6" for drift. Make certain that at the lowest point of hook travel a minimum of 1 turn of wire rope remains on rope drum.
- (6) Locate cam adjusting pinion "B" (lower) by referring to the indicating arrow on insulation shield. Depress this screw with a screwdriver until pinion teeth mesh with gear teeth on lower cam. Rotate cam in direction cam turns when lowering by turning screwdriver until cam operates switch. White marker on gear teeth of lower cam will be directly over nylon roller that trips switch and adjustment is complete.

- (7) Retighten cam clamping screws, fold down insulating shields and replace cover.

- b. This limit switch has a rotary screw driven by a gear reduction which is coupled to the end of the drum shaft. Adjustment discs operate the contacts of separate switches; one for the hoisting circuit and one for the lowering circuit. The switch assembly must be wired in accordance with the appropriate wiring diagram, which is shipped with the hoist. Instructions for adjusting limit switch are inside switch cover and are repeated below (see Figure 7-2).

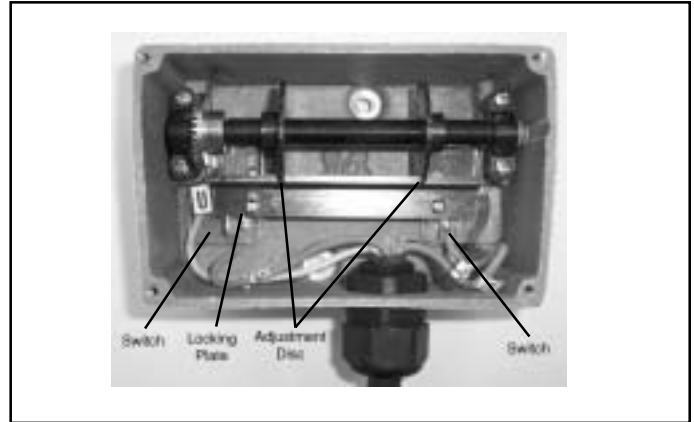

Figure 7-2. Screw-Type Limit Switch Adjustment

1. Remove four screws and lift off switch cover.
2. Loosen locking plate screws. Slide locking plate away from adjustment discs.
3. Turn proper adjustment disc (right for up, left for down) toward switch to reduce hook travel or away from switch to increase hook travel.
4. Slide locking plate back into position ensuring slots on adjustment discs are fully engaged, tighten locking plate screws to 4 in-lbs.
5. Replace cover.

▲WARNING

Check limit switch operation carefully, without load, before placing hoist in service. If misadjusted, SEVERE DAMAGE AND/OR A DROPPED LOAD COULD RESULT. Allow 6" for hook drift in both directions. Never allow less than 1 complete wrap of rope on drum with hook in lowest position.

Provide a light film of NLGI No. 2 grease on gear of both limit switches.

7-5. OVERLOAD CLUTCH ADJUSTMENT AND TESTING.

- a. When hoist is equipped with an overload clutch, minor clutch adjustments can be made with your hoist suspended. Clutch adjustment shall be supervised by an authorized person familiar with the hoist and the purpose of the adjustment and test. (See Paragraph 5-6.e for disassembly, inspection and readjustment.) To test clutch operation and make minor adjustments, proceed as follows:

⚠WARNING

Before attempting to adjust and test an overload clutch, an appointed person shall determine that the trolley and/or other supporting structure is capable of safely supporting a load equal to 175 percent of the hoist rated load plus the weight of the hoist. Failure to provide adequate support could cause injury to equipment and personnel.

With the hoist in position for testing as determined by an appointed person, attach a known load, equal to the rated load of the hoist, to the lower hook. Adequate and proper rigging shall be provided to insure test loads are securely attached, properly balanced and lifted level.

- b. Energize hoist to lift rated load. Raise this load just high enough to be certain hoist is lifting entire load. Clutch should not slip with this rated load. Lower load to rest position. If hoist will not lift rated load, clutch adjustment is required - proceed with step c.

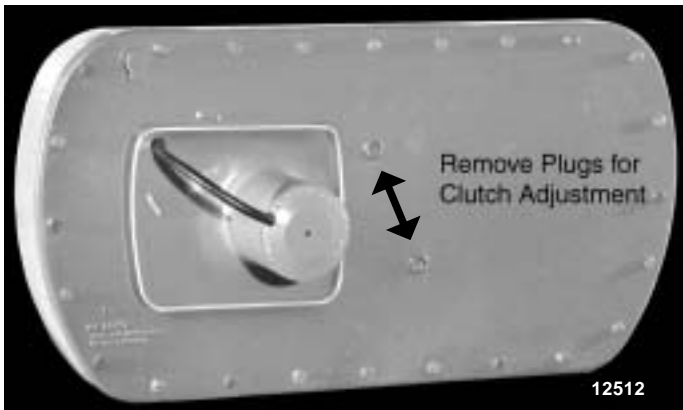

Figure 7-3. View Showing Clutch Adjustment Plug Locations

- c. Lock main power switch in open position.
- d. Provide an adequate and safe means to support workmen who are to make adjustments.
- e. Remove brake cover.
- f. Remove two pipe plugs from gearcase (see Figure 7-3).
- g. Remove motor brake actuating mechanism per Paragraphs 5-5.a and 5-5.b, and rotate motor shaft.
Note: On some hoists motor shaft can be rotated by hand; others may require the use of a plumber's strap wrench to rotate motor shaft. (DO NOT USE REGULAR PIPE WRENCH WHICH COULD SCAR SHAFT SURFACE AND REDUCE SHAFT STRENGTH.)
- h. Rotate motor shaft until the two hex socket head bolts on clutch are visible through pipe plug openings in gearcase. A small flashlight may be helpful to see hex socket head bolts.

- j. Insert T-type allen wrench thru opening in gearcase and spider into clutch bolt socket. (See Figure 9-4 for part number of adjusting wrench.)
- k. Rotate each clutch adjusting bolt clockwise 1/4 turn. Be certain each bolt is rotated an equal amount for every adjustment.
- l. Replace lower pipe plug finger tight.
- m. Replace motor brake actuating mechanism and adjust per Paragraphs 7-2.a through 7-2.f.
- n. Make certain all workmen are clear of hoist and plumber's strap wrench has been removed from motor shaft. Turn on power and energize hoist to raise rated load. Only one adjustment should be required; however, if further adjustment is required repeat steps f through n making certain POWER IS OFF for each adjustment.

With clutch adjusted to lift rated load, your hoist can now be tested for maximum load at which clutch slips. This load should not be greater than 175 percent of rated load (Rated load multiplied by 1.75).

⚠WARNING

Never lift more than hoist rated load except for clutch adjustment and testing as described in this paragraph.

To determine load at which clutch slips proceed as follows:

- p. Increase load in steps from rated load to a maximum of 175 percent of rated load, lifting load with each increase in weight. Hoist should slip and refuse to lift load before 175 percent of rated load is reached. Should hoist lift 175 percent of rated load - STOP TEST - clutch adjustment is required.
- r. Repeat steps c through j above. Rotate each clutch adjusting bolt counterclockwise approximately 1/16 turn (22-1/20).
- s. Repeat step n with less than 175 percent of load. Clutch should slip. Readjust as described in step r until clutch slips before reaching 175 percent of load.
- t. Run hoist with load causing clutch to slip (hoist refusing load) ten cycles of approximately 1 second each, to insure that hoist will not lift 175 percent of load.
- u. Remove weight added in step p and return to rated load. Lift rated load one final time. Clutch should not slip.
- v. Replace pipe plugs in gearcase. Replace brake cover. Remove ladders or other equipment used to reinforce hoist support and used by workmen.

7-6. SHORTENING OF PUSH BUTTON CABLE.

 WARNING
<p>Be certain that electrical power supply is OFF and locked in the open position before attempting shortening of push button cable.</p>

- a. Loosen screws at cable connectors and clamps.
- b. Adjust steel support cable to proper length and tighten screws.
- c. Loosen upper cable grip and pull excess cable into connection box at hoist.
- d. Tighten cable grip and cut off excess cable.
- e. Strip cable sheath and connect wires with same type of terminals previously furnished (care must be exercised to match previous wire color coding with wire markers in accordance with wiring diagram furnished with hoist.)

SECTION VIII - WIRING DIAGRAMS

Wiring diagrams for SHAW-BOX electric hoists have been omitted from this book because of many possible variations. This is due to different currents and types of electrical components used in their construction. A print of the correct wiring diagram for each hoist is furnished as a separate insert and shipped with hoist. We suggest you carefully file the wiring diagram with this book for future reference.

SECTION IX - PARTS LIST

9-1. GENERAL. The parts lists and illustrations in this section of the manual cover parts for all standard and low head room models Series "700" SHAW-BOX Electric Hoists. A typical hoist is shown as the basis for the exploded parts illustrations; therefore, certain variations may occur from the information given. For this reason, always give the Hoist Serial Number, Catalog Number, Motor Horsepower, Voltage, Phase, Frequency and Capacity of Hoist when ordering parts.

SHAW-BOX Series "700" Hoists are built in two basic sizes, Size 2, and Size 3. To determine the size of your hoist measure the width of your hoist at the gearcase cover. Size 2 hoists measure 24-3/4 inches and Size 3 hoists measure 34-1/4 inches. Select part numbers and quantities in the column corresponding to the size of your hoist.

Certain parts of your hoist will, in time, require replacement under normal wear conditions. It is suggested that these parts be purchased for your hoist as spares for future use. These parts are indicated by a (t) symbol at the side of the parts reference numbers.

<p>The numbers assigned to the parts of our various assemblies in our parts list are not the part numbers used in manufacturing the part. They are identification numbers, that when given with the model number, permit us to identify, select or manufacture, and ship the correct part needed.</p>
--

9-2.

LIST OF PARTS ILLUSTRATIONS					
	Figure No.	Page No.		Figure No.	Page No.
Frame, Gearcase, Motor and External Covers	9-1	26	Electrical Control Equipment:		
Suspension Parts for Low Headroom Hoists	9-2	28	Size 2 Hoists	9-10	38
Drum, Shaft, Gear and Bearings	9-3	29	Size 3 Hoists Thru 15 Tons Only	9-10a	39
Mechanical Load Brake Parts (Includes Overload Clutch Parts)	9-4	30	Size 3 Hoists, 20 and 25 Tons	9-10b	40
Motor Pinion Shaft, Coupling and Motor Brake Parts	9-5	31	Size 2 Hoists (Later Models)	9-10c	42
Motor Brake Actuating Mechanism	9-6	32	Size 3 Hoists (Later Models)	9-10d	44
Upper Limit Switch Parts - Block Operated:			Push Button Station and Conductor Cord Assembly	9-11	46
Single Reeved Hoists	9-7	33	Upper and Lower Block Parts Including Hoist Rope:		
Double Reeved Hoists	9-7a	34	Standard Headroom Hoists:		
Low Headroom Hoists	9-8	35	2 thru 7-1/2 Ton - Single Reeved		
Upper and Lower Limit Switch:			- 1/4", 5/16", 3/8", 7/16" Rope	9-14	48
Geared Rotary Type	9-9	36	2 thru 5 Ton - Double Reeved		
Geared Rotary Type	9-9a	37	- 3/8" Rope	9-16	52
			5 thru 15 Ton - Single Reeved		
			- 9/16" Rope	9-15	50

LIST OF PARTS ILLUSTRATIONS (Continued)

Title	Figure No.	Page No.	Title	Figure No.	Page No.
Upper and Lower Block Parts: (Continued)			Upper and Lower Block Parts: (Continued)		
Standard Headroom Hoists: (Continued)			Standard Headroom Hoists: (Continued)		
6 thru 10 Ton - Double Reeved - 5/16" & 3/8" Rope	9-15	50	20 and 25 Ton - Single Reeved - 1/2" & 9/16" Rope	9-21	62
7-1/2 Ton - Single Reeved - 3/8" Rope	9-19	58	Low Headroom Hoists:		
10 Ton - Single Reeved - 7/16" Rope	9-20	59	2 thru 5 Ton - 2 PD Reeved - 5/16" & 3/8" Rope	9-16	52
10 Ton - Double Reeved - 5/16" Rope	9-20a	60	2 thru 7-1/2 Ton - 3 PD Reeved - 5/16" & 3/8" Rope	9-17	54
15 and 20 Ton - Double Reeved - 7/16" Rope	9-22	64	10 Ton - 4 PD Reeved 3/8" Rope	9-18	56
			PD = Part Double		

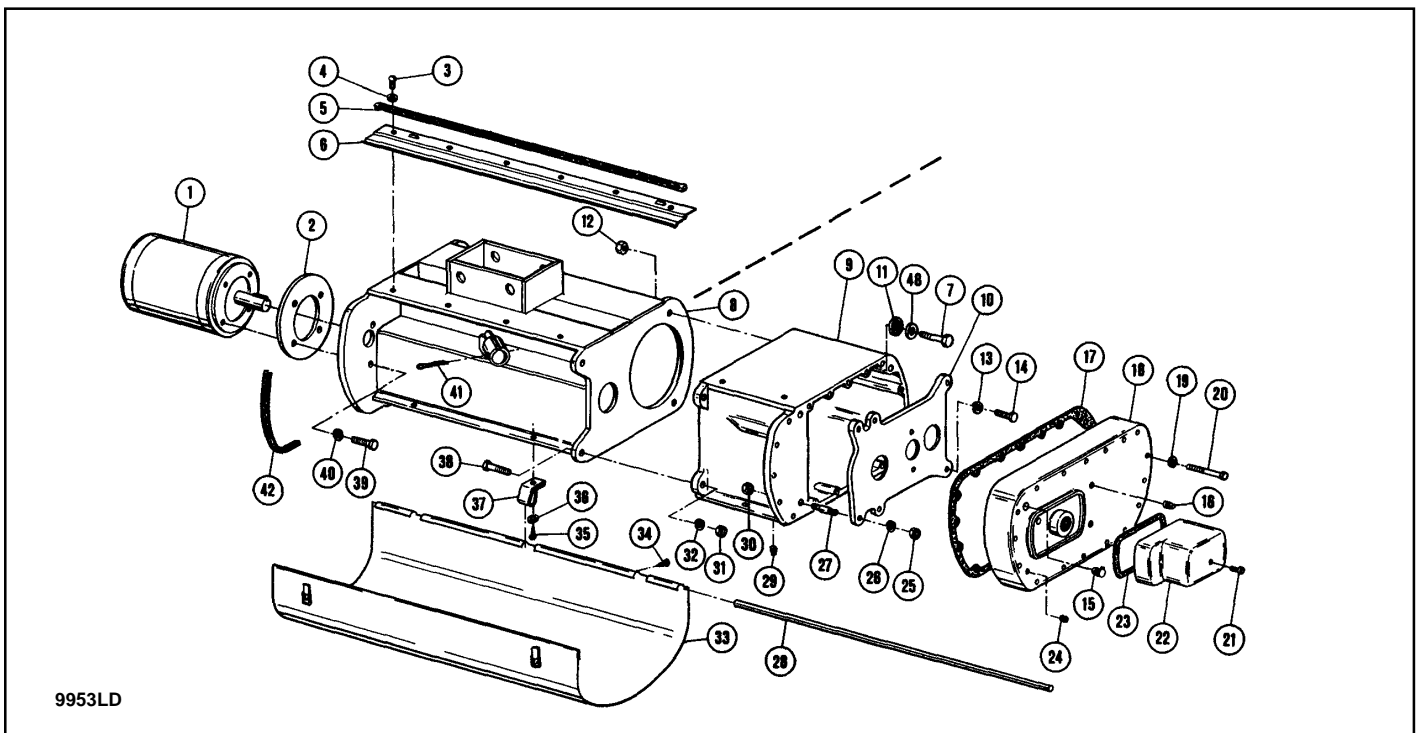

Figure 9-1. Frame, Gearcase, Motor and External Covers

Ref. No.	Part Number	Description	Quantity Required	
			Size 2 Hoist	Size 3 Hoist
1	700-101	Motor Assembly (includes key)	1	1
2	700-150	Spacer - Motor (not used on all models)	-	1
3	700-112	Screw - Round Head, Self-tapping	4	6
4	700-113	Lockwasher	4	6
5	700-114	Gasket - Cover Bridge	1	1
6	700-115	Bridge Assembly - Cover	1	1
7	700-151	Fit Bolt - Hex Head	2	2
8	700-116	Frame - Hoist (typical frame shown)	1	1
9	700-117	Gearcase - Hoist	1	-
	700-179	Gearcase - Hoist	-	1
10	700-118	Spider - Gearcase	1	-
	700-178	Spider - Gearcase	-	1
11	700-120	Washer - "0" Ring Type	2	2
12	700-119	Nut - Hex, Self-locking	2	2

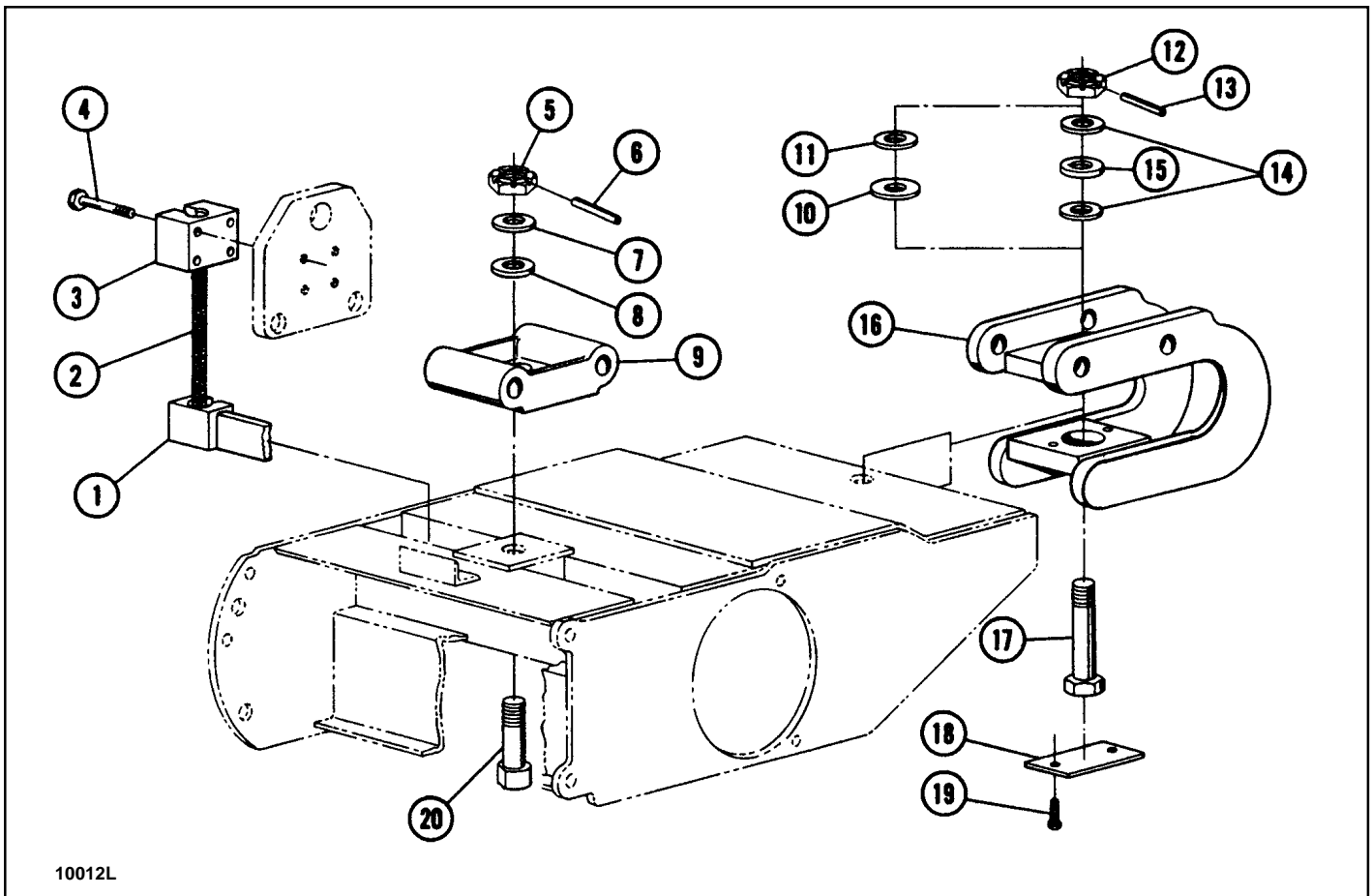

Figure 9-2. Suspension Parts for Low Headroom Hoists

Ref. No.	Part Number	Description	Quantity Required	
			Size 2 Hoist	Size 3 Hoist
1	700-232	*Crossbar - Redundant Support	1	1
2	700-233	Wire Rope Assembly - Redundant Support	2	2
3	700-234	Rope Sleeve Pocket	2	2
4	700-235	Bolt - Hex Head, Self-locking	8	8
5	700-236	Nut - Hex, Slotted	1	1
6	700-237	Pin - Drive	1	1
7	700-238	Machinery Bushing	1	1
8	700-239	Bearing - Thrust	1	1
9	700-224	Crosshead - Trailer	1	1
10	700-240	Bearing - Thrust	-	1
11	700-241	Machinery Bushing	-	1
12	700-242	Nut - Hex, Slotted	1	1
13	700-243	Pin - Drive	1	1
14	700-244	Bearing Race	2	-
15	700-245	Bearing - Thrust	1	-
16	700-201	Crosshead - Driver	1	1
17	700-204	Loadbolt - Driver	1	1
18	700-246	Plate - Retainer	1	1
19	700-247	Screw - Round Head, Self-locking	2	2
20	700-213	Loadbolt - Trailer	1	1

* Correct monorail beam size must be given when ordering this part.

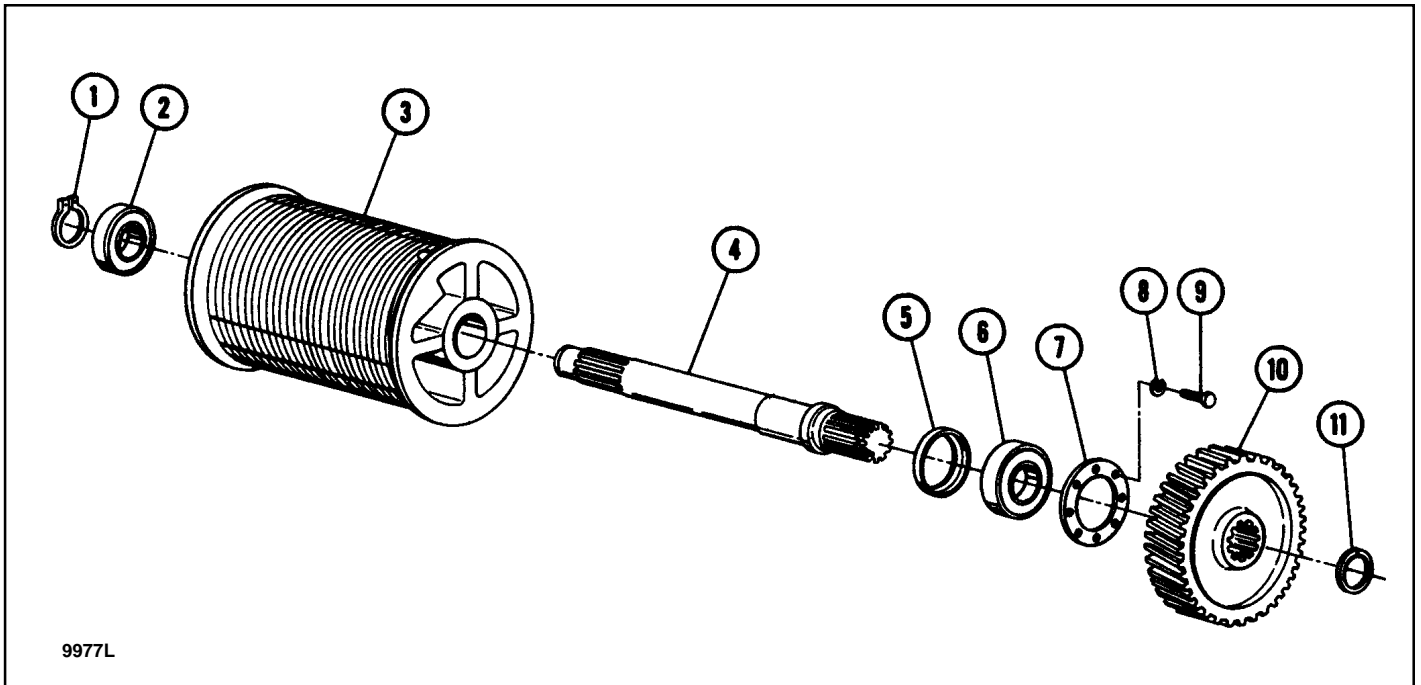

Figure 9-3. Drum, Shaft, Gear and Bearings

Ref. No.	Part Number	Description	Quantity Required	
			Size 2 Hoist	Size 3 Hoist
1	700-314	Ring - Retaining, External	1	1
2	700-304	Bearing - Drum Shaft	1	1
3	700-305	*Drum	1	1
4	700-306	*Shaft - Drum	1	1
5	700-307	Seal - Oil, Drum Shaft	1	1
6	700-308	Bearing - Drum Shaft	1	1
7	700-309	Retainer - Bearing, Drum Shaft	1	1
8	700-313	Lockwasher	8	4
9	700-312	Bolt - Hex Head	8	4
10	700-310	Gear - Drum	1	1
11	700-311	Ring - Retaining, External	1	1

*Drums on some models have drum shaft integral (Ref. No. 4). Drums for low headroom models and some longer lift models, have right and left hand grooves.

NOTES

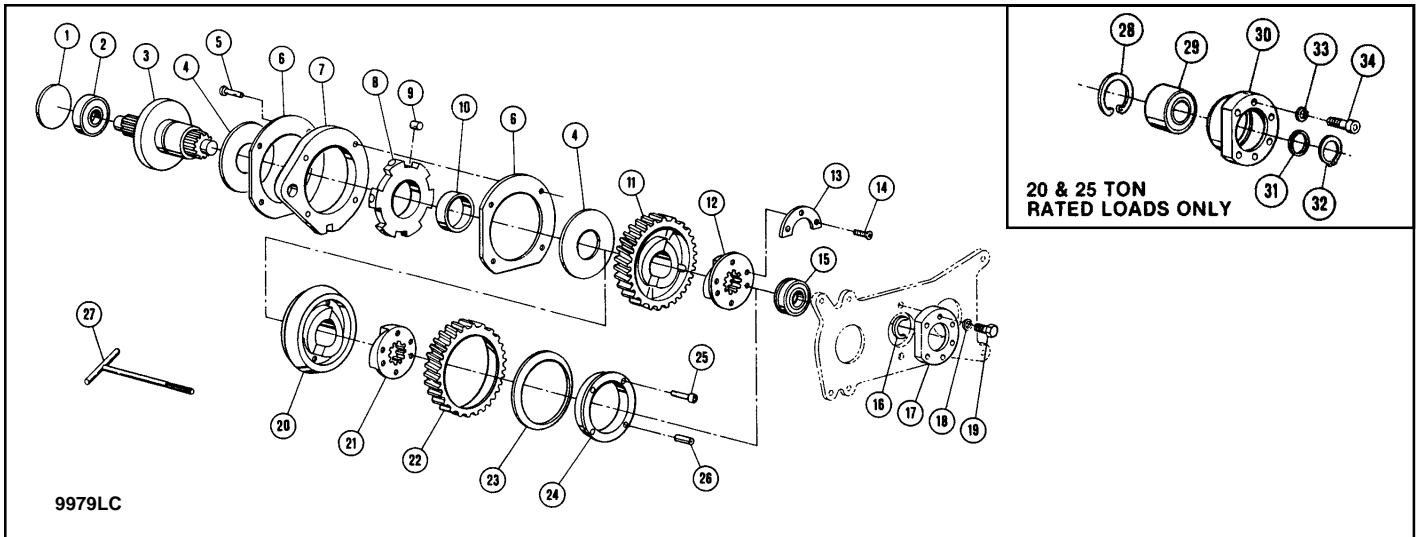

Figure 9-4. Mechanical Load Brake Parts (Includes Overhead Clutch Parts)

Ref. No.	Part Number	Description	Quantity Required	
			Size 2 Hoist	Size 3 Hoist
1	700-401	Plug - Expansion (not used on later models)	1	-
2	700-402	Bearing	1	1
3	700-403	Shaft and Flange Assembly, Brake	1	1
4	700-404	Washer - Friction	2	2
5	700-405	*Roller and Ratchet Assembly Brake (includes Ref. Nos. 5 through 10)	1	1
	700-406	Rivet - Flat Head	4	-
	700-417	Bolt - Hex Head (with nut)	-	6
6	700-407	Plate - Roller Retaining	2	2
7	700-408	Race - Roller	1	1
8	700-409	Ratchet -Roller	1	1
9	700-410	Roller	6	6
10	700-411	Bushing - Bronze	1	1
11	700-412	Gear - Brake	1	1
12	700-413	Helix - Brake	1	1
13	700-414	Plate - Retaining	2	2
14	700-415	Screw - Flat Head Socket, Self-locking	4	-
	700-418	Screw - Socket Head Cap, Self-locking	-	6
15	700-416	***Bearing	1	1
16	700-419	Ring - Retaining, External	-	1
17	700-420	Cap - Retaining, Bearing	-	1
18	700-421	Lockwasher	-	6
19	700-422	Bolt - Hex Head	-	6
20	700-423	**Center Assembly - Gear	1	1
21	700-424	**Helix - Brake	1	1
22	700-425	**Gear - Brake	1	1
23	700-426	**Spring - Belleville	1	1
24	700-427	**Collar - Adjusting	1	1
25	700-428	**Screw - Socket Head, Self-locking	2	2
26	700-429	**Pin - Groove	2	2
27	700-430	Tool - Clutch Adjusting	1	1
28	700-431	***Ring.- Retaining	-	1
29	700-432	***Bearing	-	1
30	700-433	***Cage - Bearing	-	1
31	700-434	***Washer - Support	-	1
32	700-435	***Ring - Retaining	-	1
33	700-436	***Lockwasher	-	6
34	700-437	***Screw - Socket Head Cap	-	6

* When Ref. Nos. 5 through 10 require replacement, the factory recommends use of above assembly instead of individual parts. On some models Ref. Nos. 8 and 10 are integral.

** Ref. Nos. 20 through 26 are used only on hoists equipped with overload clutch.

*** For 20 & 25 ton rated loads only, Ref. Nos. 28 through 34 replace Ref. Nos. 15 through 19.

**** Size 2 shown. On Size 3 rotate bearing 180° and install from outside of spider.

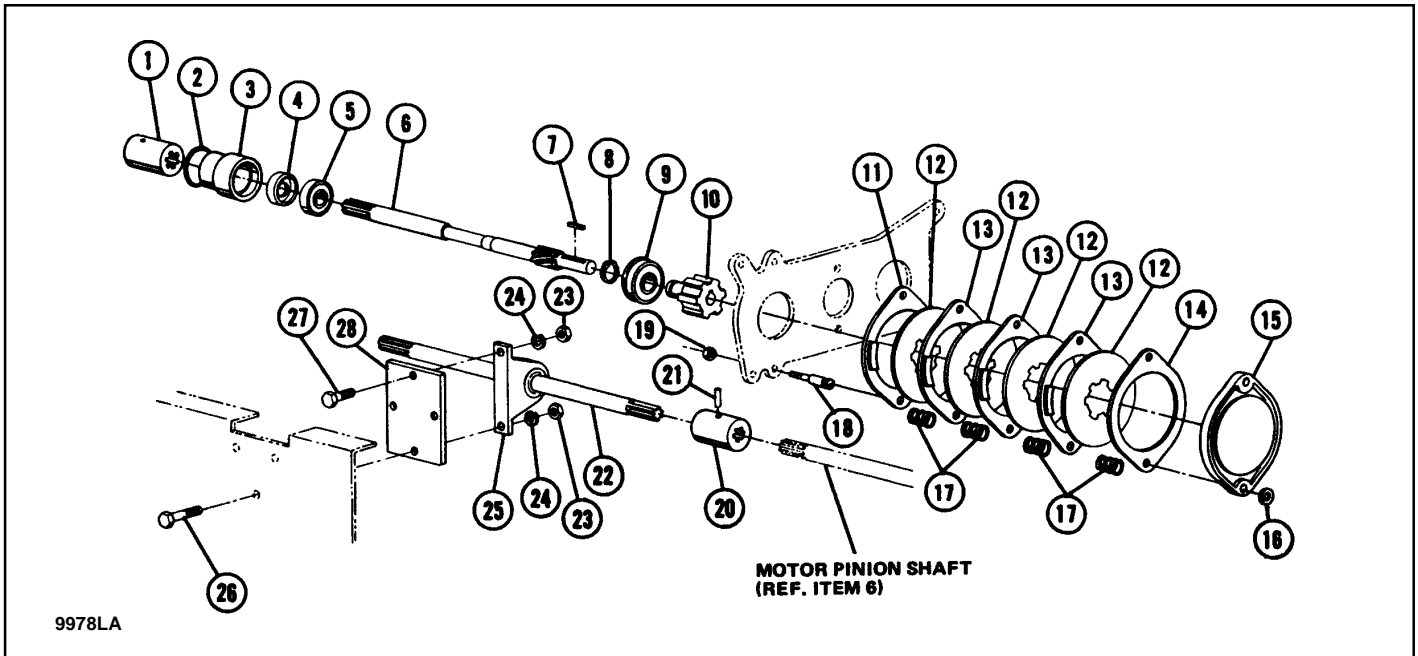

Figure 9-5. Motor Pinion Shaft, Coupling and Motor Brake Parts

Ref. No.	Part Number	Description	Quantity Required	
			Size 2 Hoist	Size 3 Hoist
1	700-501	Coupling - Motor	1	1
	700-530	Ring - Retaining (not shown)	1	-
	700-531	Pin - Drive (not shown)	-	1
2	700-502	Gasket - "O" Ring	1	1
3	700-503	Cage - Bearing	1	1
4†	700-504	Seal - Oil	1	1
5	700-505	Bearing	1	1
6	700-506	Shaft - Motor Pinion (with keyway)	1	-
	700-519	Shaft - Motor Pinion (with spline)	-	1
7	700-507	Key 1	-	-
8	700-508	Ring - Retaining, External	1	1
9	700-509	Bearing	1	1
10†	700-510	Hub - Motor Brake (with keyway)	1	-
	700-520	Hub - Motor Brake (with spline)	-	1
11†	700-551	Washer & Lining Assembly - Spider End	1	1
12†	700-553	Plate - Motor Brake	4	4
13†	700-552	Washer & Lining Assembly - Intermediate	3	3
14†	700-555	Washer & Lining Assembly - Pressure Plate End	1	1
15	700-556	Plate - Compression	1	1
16**	700-514	Ring - Retainer, External	2	2
17†	700-515	Spring - Release	8	8
18	700-516	Stud - Pilot	2	2
19	700-518	Nut - Hex, Self-locking	2	2
20	700-521	*Coupling - Shaft, Intermediate	1	1
21	700-522	*Pin - Drive	1	-
22	700-523	*Shaft - Intermediate	1	1
23	700-524	*Nut - Hex	4	4
24	700-525	*Lockwasher	4	4
25	700-526	*Pillow Block - Intermediate Shaft	1	1***
26	700-527	*Bolt - Hex Head	1	1
27	700-528	*Bolt - Hex Head	3	3
28	700-529	*Plate - Mounting, Pillow Block	1	1

* Ref. Nos. 20 through 22 are used only on models with extended frames. Ref. Nos. 23 through 28 are used only on models with the longest frame extension.

** Spacers may occur between Ref. Nos. 15 and 16.

*** For hoists with 227' lift there are 2 pillow blocks and the quantity of associated hardware is twice that shown.

† Recommended spares.

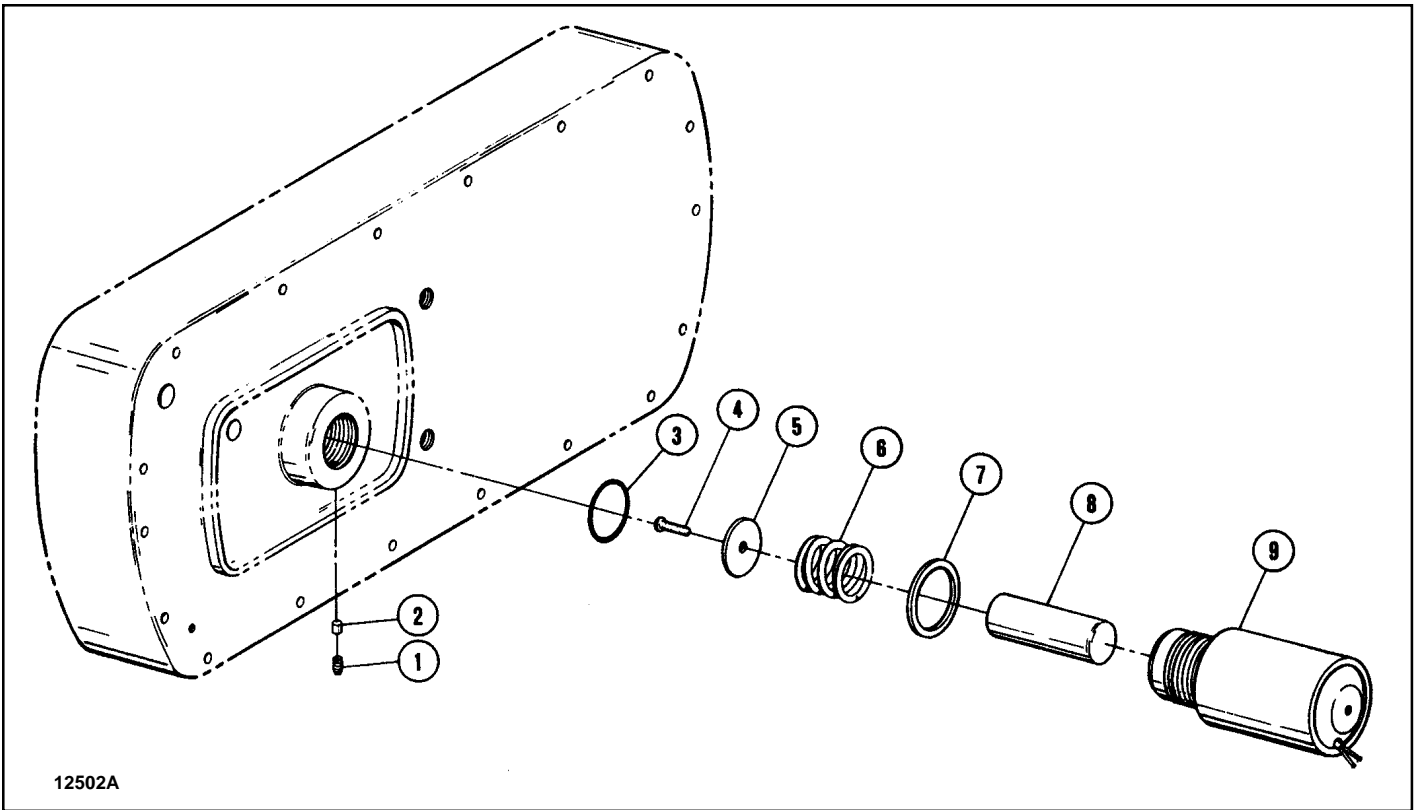

Figure 9-6. Motor Brake Actuating Mechanism

Ref. No.	Description	Size 2 Hoist		Size 3 Hoist	
		Part Number	Quan. Req'd	Part Number	Quan. Req'd
1	Screw - Hex Socket Head Set	700-673	1	700-673	1
2	Rod - Brass	700-674	1	700-674	1
3†	Seal - "O" Ring	700-675	1	700-676	1
	*Brake Actuating Assembly (includes Ref. Nos. 4, 5, 8 and 9)	700-677	1	700-678	1
4	Screw - Hex Socket Button Head Cap	700-679	1	700-679	1
5	Washer - Spring Stop	700-680	1	700-681	1
6†	Spring				
	Natural Color	700-682	1	-	-
	White	-	-	700-683	1
	Red	-	-	700-684	1
	Green	-	-	700-685	1
7	Washer - Spacer (used with red and green springs only)				
	Used with Red Spring Only	-	-	700-686	1
	Used with Green Spring Only	-	-	700-686	2
8	Plunger	700-687	1	700-688	1
9	Body Assembly	700-689	1	700-690	1
10**	Indicator Pin - Brake Adjustment	700-691	1	700-692	1
11**	Spring - Brake Pin	700-693	1	700-693	1

* When Ref. Nos. 4, 5, 8 and 9 require replacement, the factory recommends use of the above assembly instead of individual parts.

** Not shown (Inside Ref. No. 9)

† Recommended spares.

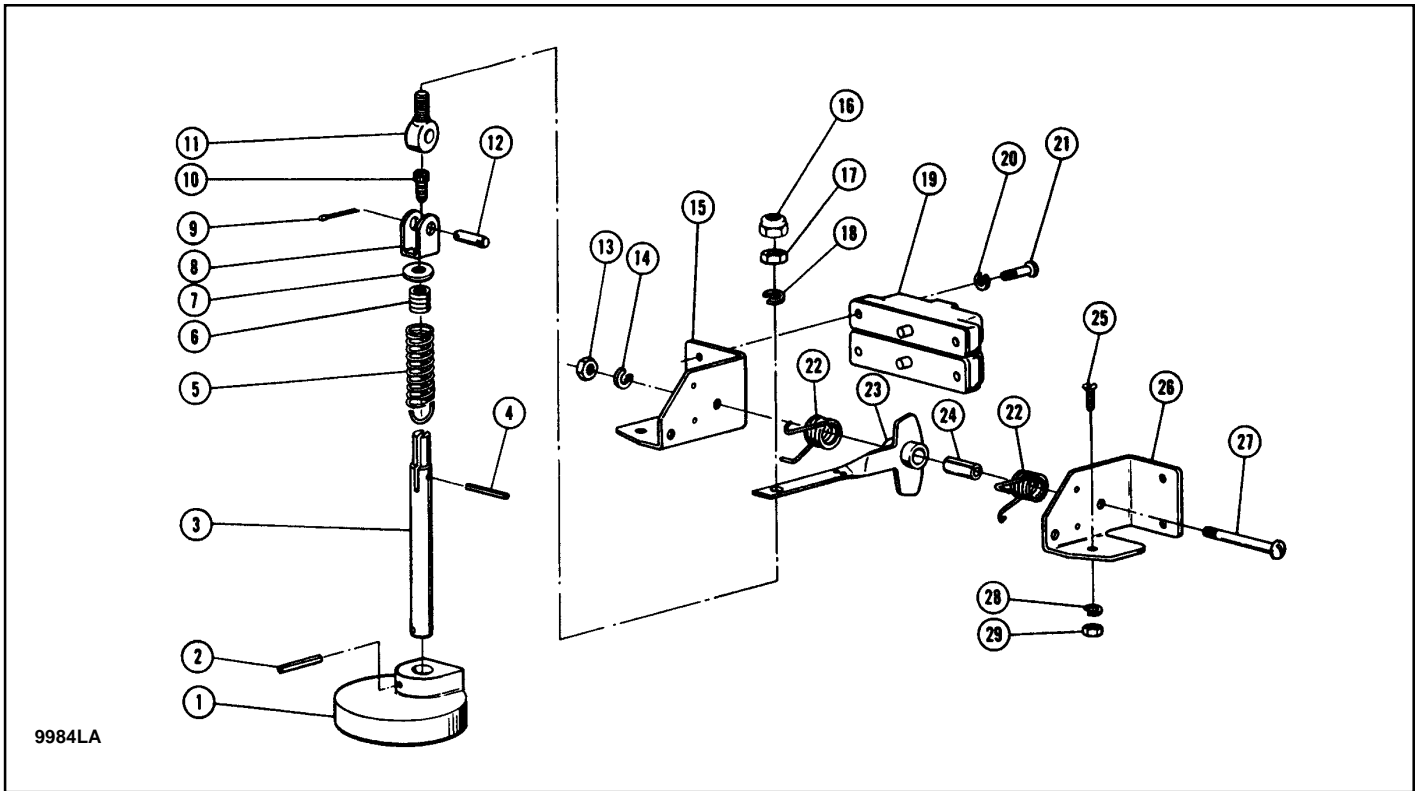
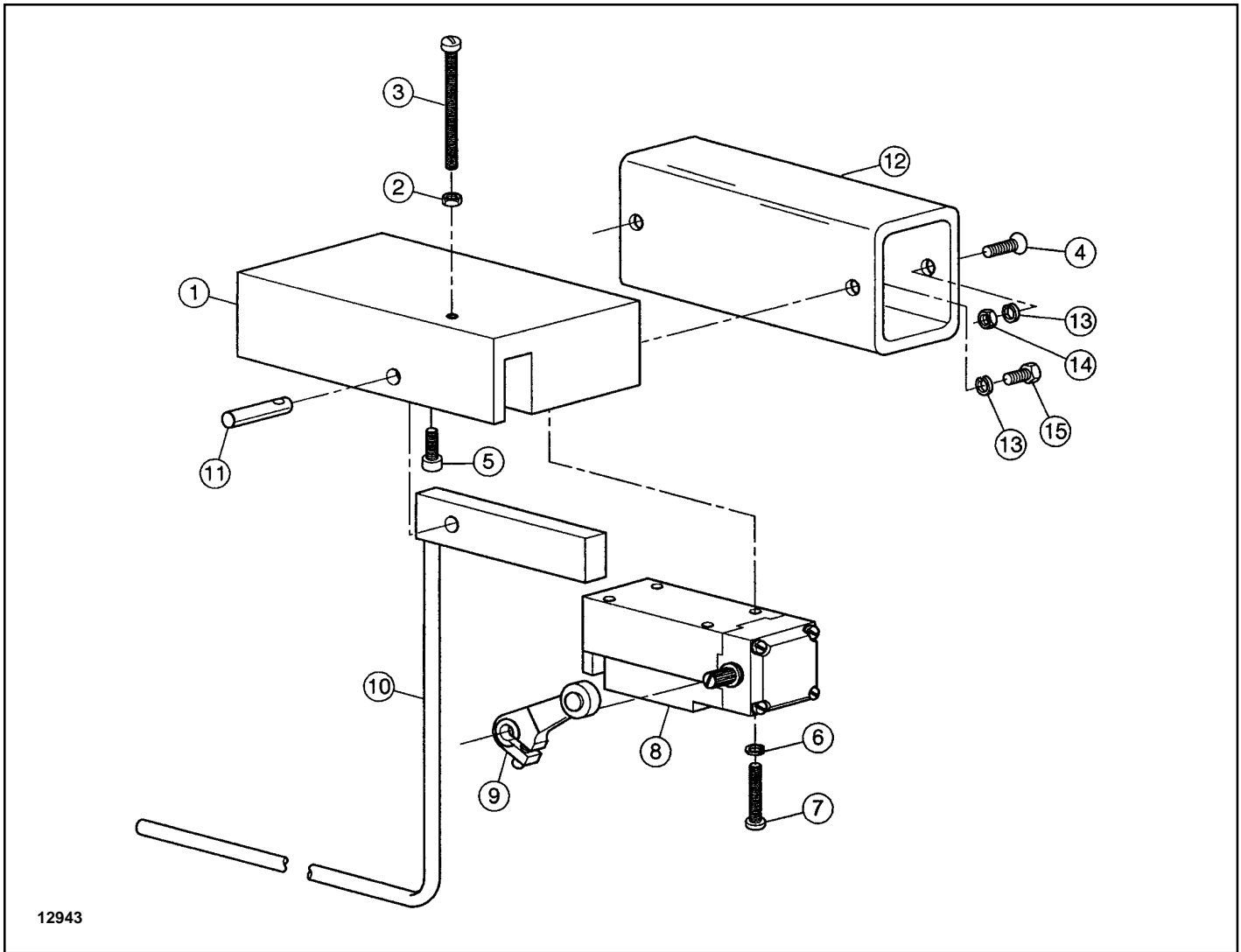

Figure 9-7. Upper Limit Switch Parts - Block Operated - Single Reeved Hoists

Ref. No.	Part Number	Description	Qty. Req'd
	700-726	Actuator Assembly - Limit Switch (includes Ref. Nos. 1 through 12 and 16 thru 18)	1
1	700-718	Weight Actuator	1
2	700-719	Pin - Drive	1
3	700-720	Rod - Actuator	1
4	700-717	Pin - Drive	1
5	700-721	Spring - Actuator	1
6	700-716	Insert - Spring	1
7	700-714	Washer - Actuator	1
8	700-727	Clevis - Actuator	1
9	700-728	Pin - Cotter	2
10	700-729	Cap Screw - Hex Socket Head	1
11	700-730	Rod End - Actuator	1
12	700-731	Pin - Actuator	1
13	700-724	Nut - Standard Hex	1
14	700-723	Lockwasher	1
15	700-701	Bracket - Limit Switch (R.H.)	1
16	700-732	Nut - Hex Cap (Optional)	1
17	700-703	Nut - Standard Hex	1
18	700-704	Lockwasher	1
19†	700-707	Switch Assembly - Upper Limit	2
20	700-709	Lockwasher	4
21	700-708	Screw - Round Head Machine	4
22	700-705	Spring - Lever	2
23	*	Lever Assembly - Limit Switch	1
24	700-712	Spacer - Limit Switch Lever	1
25	700-702	Screw - Flat Head Machine	2
26	700-710	Bracket - Limit Switch (L.H.)	1
27	700-711	Screw - Round Head Machine	1
28	700-725	Lockwasher	1
29	700-722	Nut - Standard Hex	1

*Replacement for Lever Assembly is Lever (Part Number 700-736) plus Hub (Part Number 700-737).

†Recommended spares.



12943

Figure 9-7a. Upper Limit Switch Parts - Block Operated - Double Reeved Hoists

Ref. No.	Part Number	Description	Qty. Req'd
		Limit Switch Assembly	1
	700-2700	For 3, 4 and 6 Part Double Reeving (Includes Ref. Nos. 1 thru 11)	
	700-2701	For 2 Part Double Reeving (Includes Ref. Nos. 1 thru 15)	
1	700-2702	Mounting Block	1
2	700-2703	Heavy Hex Nut (1/4-20)	1
3	700-2704	Fillister Head Machine Screw (1/4-20 x 2-3/4)	1
4	700-2705	Flat Head Machine Screw (5/16-18 x 1)	2
5	700-2706	Self-Locking Hex Socket Head Cap Screw - Plated (1/4-20 x 1/2)	1
6	700-2707	Lockwasher (#10)	2
7	700-2708	Phillips Pan Head Machine Screw (#10-24 x 1-1/4)	2
8†	700-2709	Limit Switch	1
9	700-2710	Actuator Arm	1
10	700-2711	Limit Switch Lever Arm	1
11	700-2712	Lever Arm Pin	1
12	700-2713	Tube	1
13	700-2714	Lockwasher (5/16)	4
14	700-2715	Heavy Hex Nut (5/16)	2
15	700-2716	Hex Head Machine Bolt (5/16-18 x 3/4)	2
		Not Shown - On Lower Block For 700-2700 Only:	
	700-2717	Striker Plate	1
	700-2718	Self-Tapping Screw With Phillips Recessed Pan Head - Plated (1/4-20 x 7/8)	2

†Recommended spares.

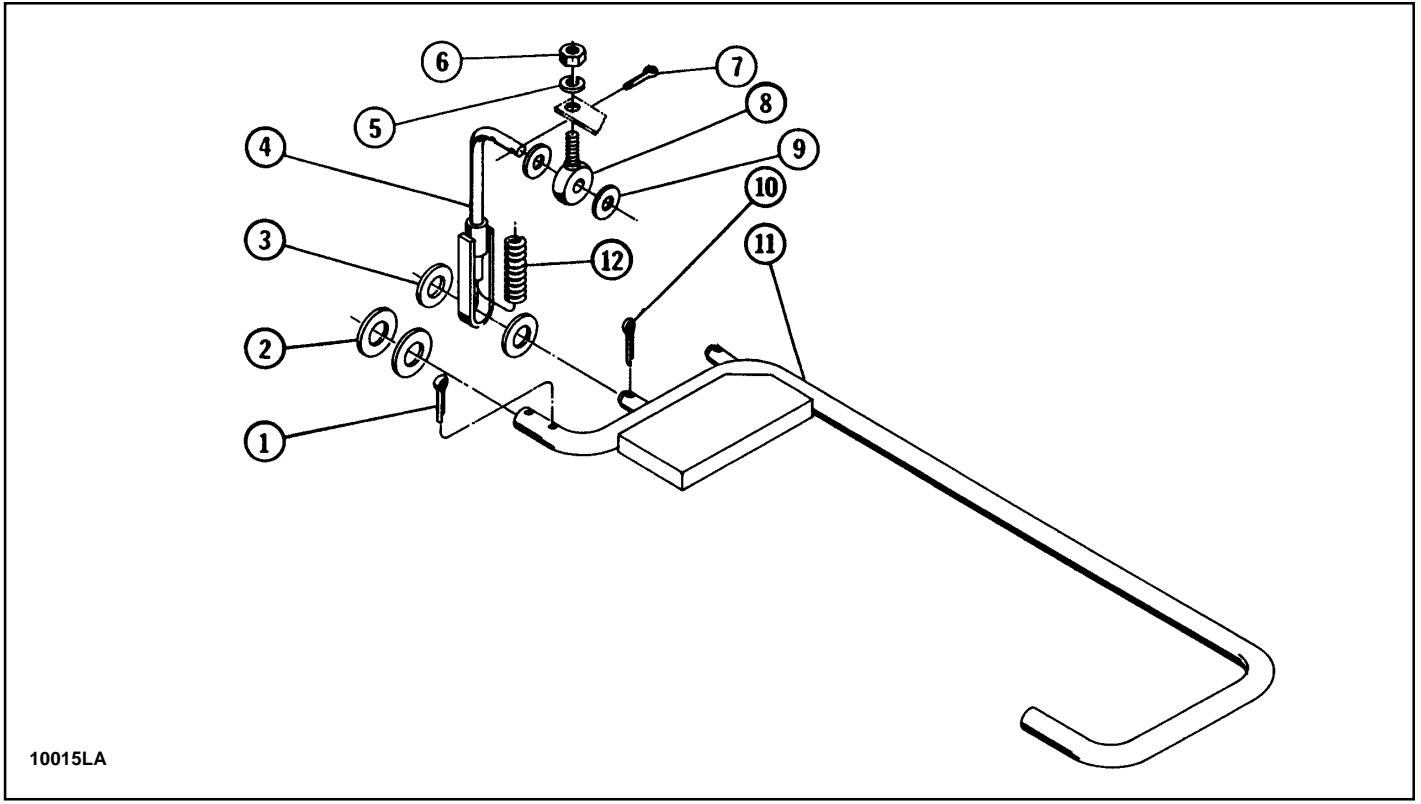

10015LA

Figure 9-8. Upper Limit Switch Parts - Block Operated - Low Headroom Hoists

Ref. No.	Part Number	Description	Qty. Req'd
1	700-751	Pin - Cotter	2
2	700-752	Washer	2
3	700-753	Washer	2
4	700-754	Connecting Rod Assembly	1
5	700-755	Lockwasher	1
6	700-756	Nut - Hex	1
7	700-757	Pin - Cotter	2
8	700-758	Rod End	1
9	700-759	Washer	2
10	700-760	Pin - Cotter	1
11	700-761	Actuator	1
12	700-762	Spring	1

For limit switch catalog numbers, see Figure 9-7, Ref. No. 13 through 15 and 19 through 29.

NOTES

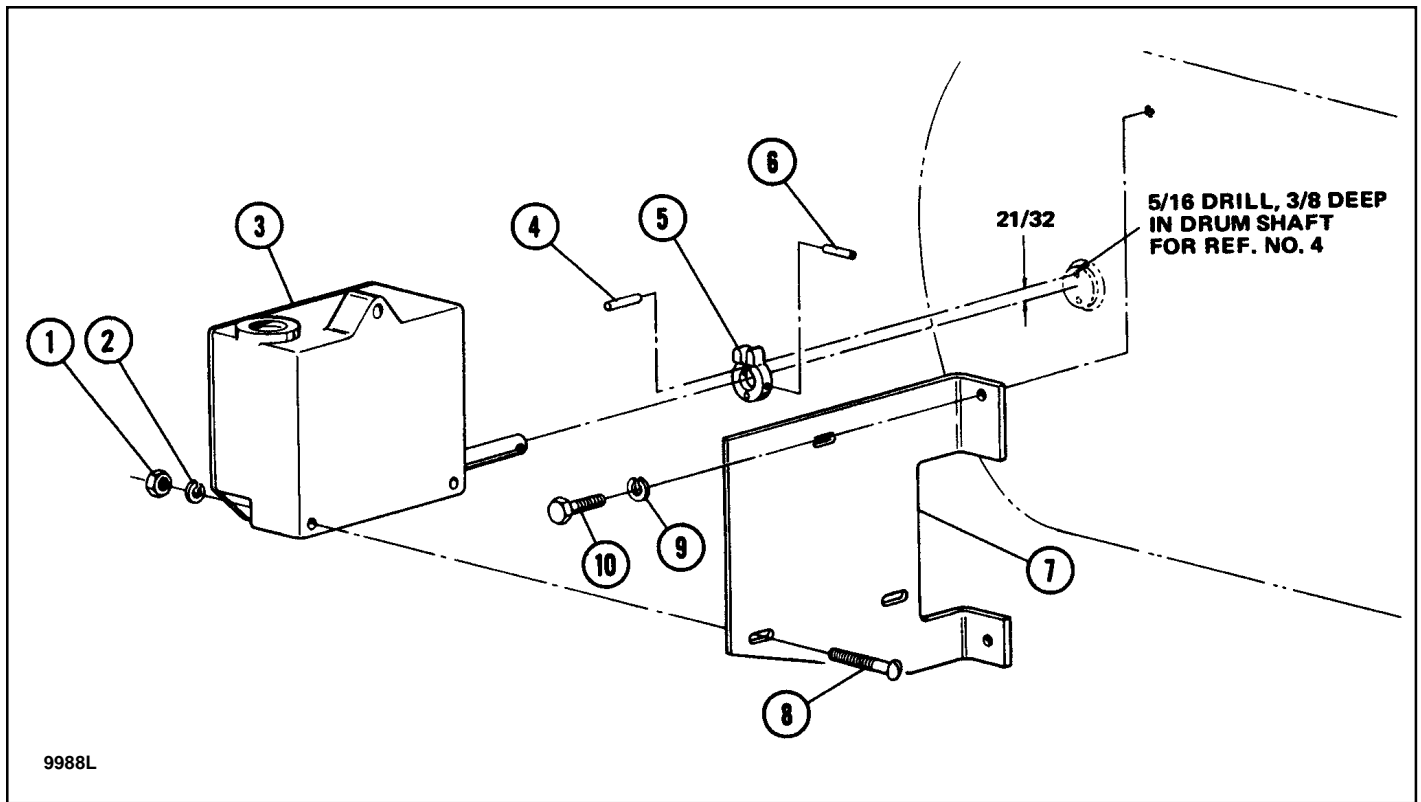

Figure 9-9. Upper and Lower Limit Switch - Geared Rotary Type. (Early Model Hoists)

Ref. No.	Part Number	Description	Qty. Req'd
1	700-916	Nut - Hex, Jam	3
2	700-917	Lockwasher - Spring Type	3
3	700-918	Switch - Geared, Rotary	1
4	700-919	Rollpin - Drum Shaft	1
5	700-920	Crank	1
6	700-921	Rollpin - Crank	1
7	700-922	Plate - Switch Mounting	1
8	700-923	Screw - Round Head, Slotted	3
9	700-924	Lockwasher	2
10	700-925	Bolt - Hex Head	2

NOTES

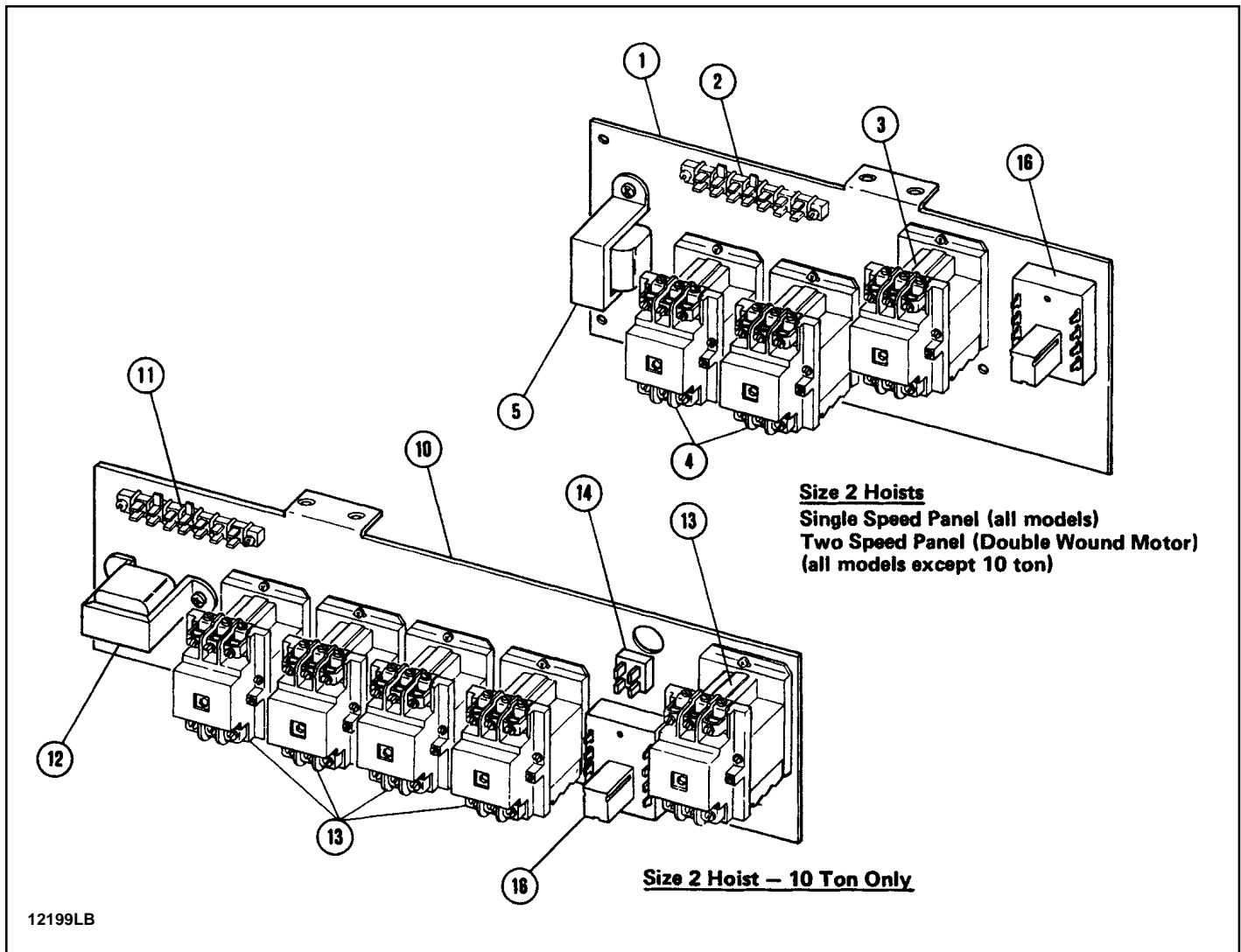

Figure 9-10. Electrical Control Equipment

Ref. No.	Part Number	Description	Qty. Req'd
1	700-1088	Plate - Mounting, Contactor	1
2	700-1026	Terminal Board	1
3†	700-1027	Contactors - two speed only	1
4†	700-1028	Contactors	1
5†	700-1086	*Transformer	1
6	700-1030	Terminal Board - single speed only (not shown)	1
7†	700-1031	*Contact Kit - single speed (not shown)	1
8†	700-1032	*Contact Kit - two speed	1
9†	700-1033	Coil - single speed (not shown)	2
		Coil - two speed	1
10	700-1035	Plate - Mounting, Contactor (10 ton - two speed only)	1
11	700-1036	Terminal Board (10 ton - two speed only)	1
12†	700-1087	**Transformer (10 ton - two speed only)	1
13†	700-1038	Contactors (10 ton - two speed only)	1
14	700-1039	Relay - Timing	1
15†	700-1040	*Contactors Kit (10 ton - two speed only)	1
16†	700-1084	Controller - Brake	1
17†	700-1091	Fuse, Fuse Holder and Wire Assembly (not shown)	1

* Order one (1) contact kit per contactor.

** Furnish complete nameplate data from old transformer.

† Recommended spares.

Note: When ordering coils, contactors, contactor kits, or brake controllers, specify voltage.

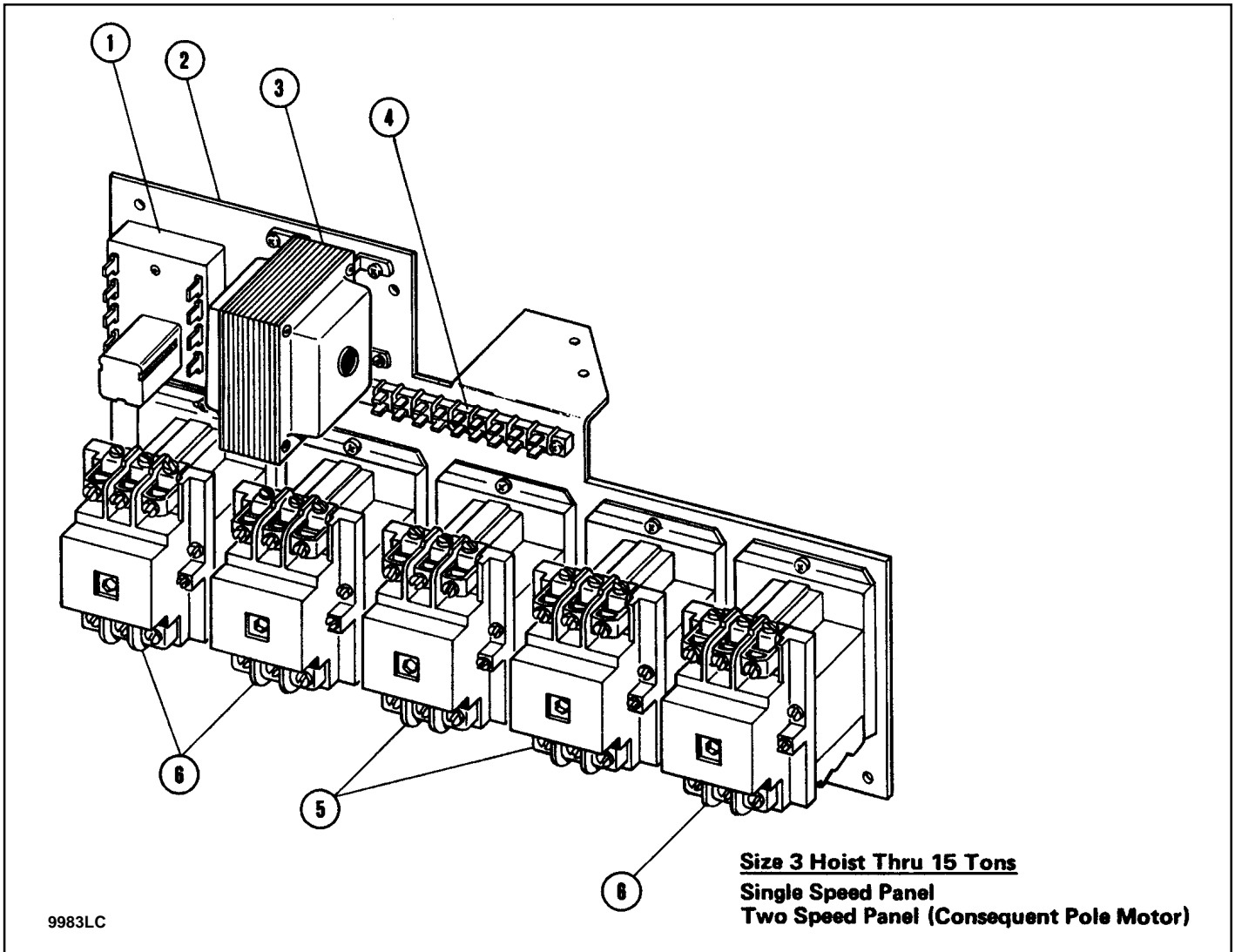

Figure 9-10a. Electrical Control Equipment

Ref. No.	Part Number	Description	Qty. Req'd
1†	700-1084	Controller - Brake	1
2	700-1085	Plate - Contactor Mounting	1
3		*Transformer	1
	700-1086	Single speed Hoist	
	700-1087	Two speed Hoist	
4	700-1022	Terminal Board	1
5†	700-1011	**Contactor - Accelerating	2
6†	700-1003	Contactor	2
7	700-1019	Block Assembly - Terminal (not shown)	1
8†	700-1023	***Contact Kit - 3-Pole (not shown)	1
9†	700-1024	***Coil (not shown)	1
10†	700-1034	***Interlock - electrical contactor - replace in pairs (not shown)	2
11†	700-1092	Fuse, Fuse Holder and Wire Assembly (not shown)	1

* Furnish complete nameplate data from old transformer.

** Parts used on two-speed hoists only.

*** Order one (1) per contactor.

† Recommended spares.

Note: When ordering relay, contactors, contact kits, coils or brake controller, specify voltage.

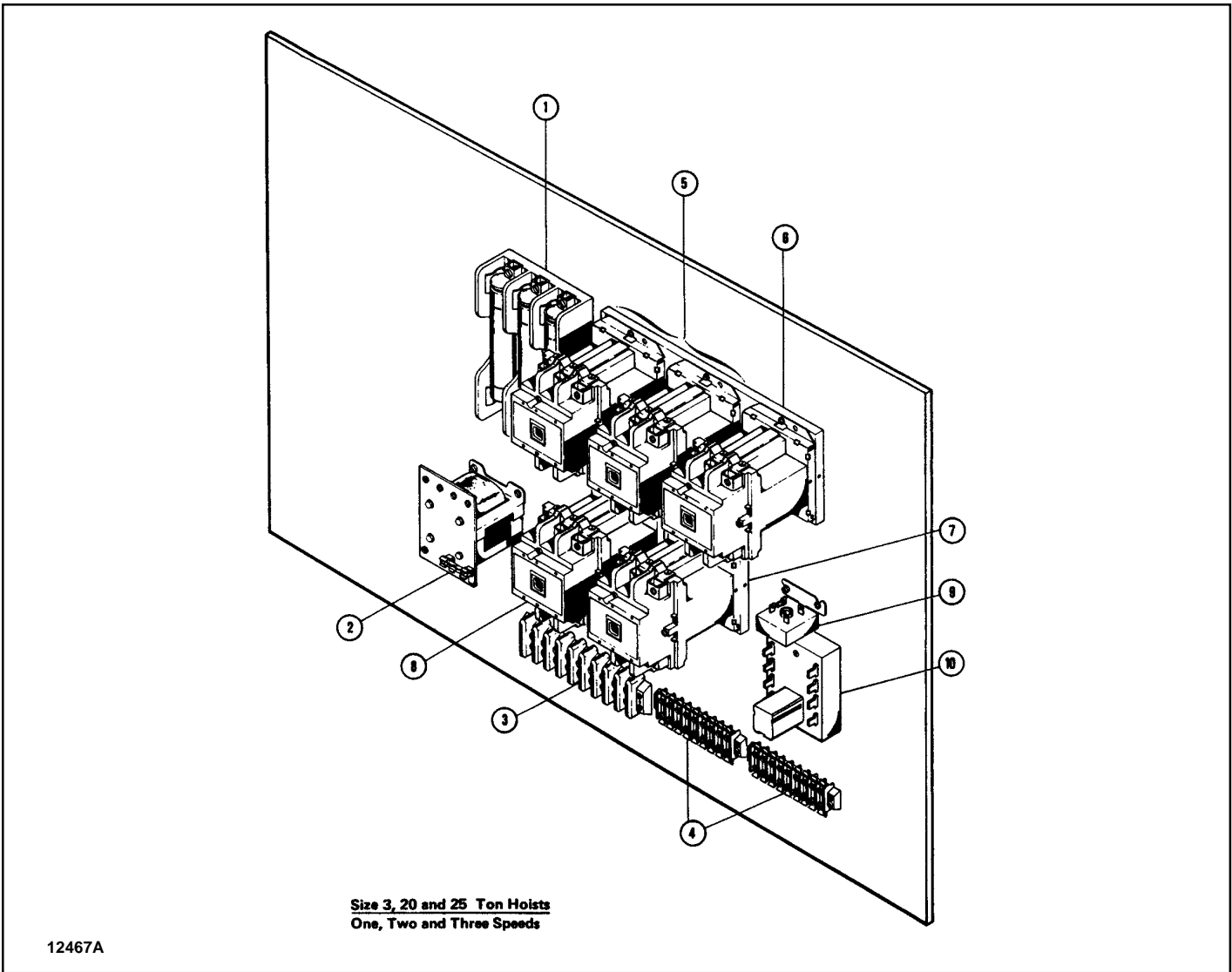

Figure 9-10b. Electrical Control Equipment

Ref. No.	Part Number	Description	Quantity Required		
			One Speed	Two Speed	3 Speed Points
1	700-1050	Kit - Hoist Motor Fuse (Optional)	1	1	1
	700-1051	15 HP, 208/230V			
	700-1052	15 HP, 460V			
	700-1053	15 HP, 575V			
	700-1054	20 HP, 208/230V			
	700-1055	20 HP, 460V			
	700-1056	20 HP, 575V			
	700-1057	25 HP, 208/230V			
	700-1058	25 HP, 460V			
	700-1058	25 HP, 575V			
		Replacement Fuses	3	3	3
	700-1059	15 HP, 208/230V			
	700-1060	15 HP, 460V			
	700-1061	15 HP, 575V			
	700-1062	20 HP, 208/230V			
	700-1063	20 HP, 460V			
	700-1060	20 HP, 575V			
	700-1064	25 HP, 208/230V			
700-1065	25 HP, 460V				
700-1063	25 HP, 575V				

Ref. No.	Part Number	Description	Quantity Required		
			One Speed	Two Speed	3 Speed Points
2	700-1087	Transformer 230/460V	1	1	1
	700-1089	208V			
	700-1090	575V			
	700-1091	Transformer Fuse	1	1	1
3	700-1070	Terminal Board - Motor	1	-	1
	700-1071	Terminal Board - Motor	-	1	-
4	700-1072	Terminal Board - Control	2	2	2
5†	700-1073	Contactor - Reversing (Double)	1	1	-
	700-1074	Replacement Coil	2	2	-
	700-1075	Contact Kit	2	2	-
		Contactor - Reversing (Double)			
	700-1073	All except 25 HP, 230V	-	-	1
	700-1074	Replacement Coil	-	-	2
	700-1075	Contact Kit.	-	-	2
	700-1076	25 HP, 230V Only	-	-	1
6†	700-1077	Contactor - Accelerating (Single)	-	1	-
	700-1074	Replacement Coil	-	1	-
	700-1075	Contact Kit	-	1	-
7†	700-1073	Contactor - Reversing (Double)	-	1	-
	700-1074	Replacement Coil	-	2	-
	700-1075	Contact Kit	-	2	-
		Contactor - Accelerating (Single)			
	700-1078	15 and 20 HP Only	-	-	1
	700-1074	Replacement Coil	-	-	1
	700-1079	Contact Kit	-	-	1
	700-1077	25 HP Only	-	-	1
	700-1074	Replacement Coil	-	-	1
	700-1075	Contact Kit	-	-	1
8†		Contactor - Accelerating (Single)			
	700-1078	15 and 20 HP Only	-	-	1
	700-1074	Replacement Coil	-	-	1
	700-1079	Contact Kit	-	-	1
	700-1077	25 HP Only	-	-	1
	700-1074	Replacement Coil	-	-	1
	700-1075	Contact Kit	-	-	1
9	700-1080	Relay - Time Delay	-	1	1
10†	700-1084	Controller - Brake	1	1	1
11		Resistor - Secondary (not shown - located outside of control panel)			
	700-1081	15 HP Only	-	-	1
	700-1082	20 HP Only	-	-	1
	700-1083	25 HP Only	-	-	1
12†	700-1092	Fuse, Fuse Holder and Wire Assembly (not shown)	1	1	1

†Recommended spares.

Note: When ordering contactors, coils, contact kits or brake controller, specify voltage. When ordering transformer, furnish complete nameplate data from old transformer.

NOTES

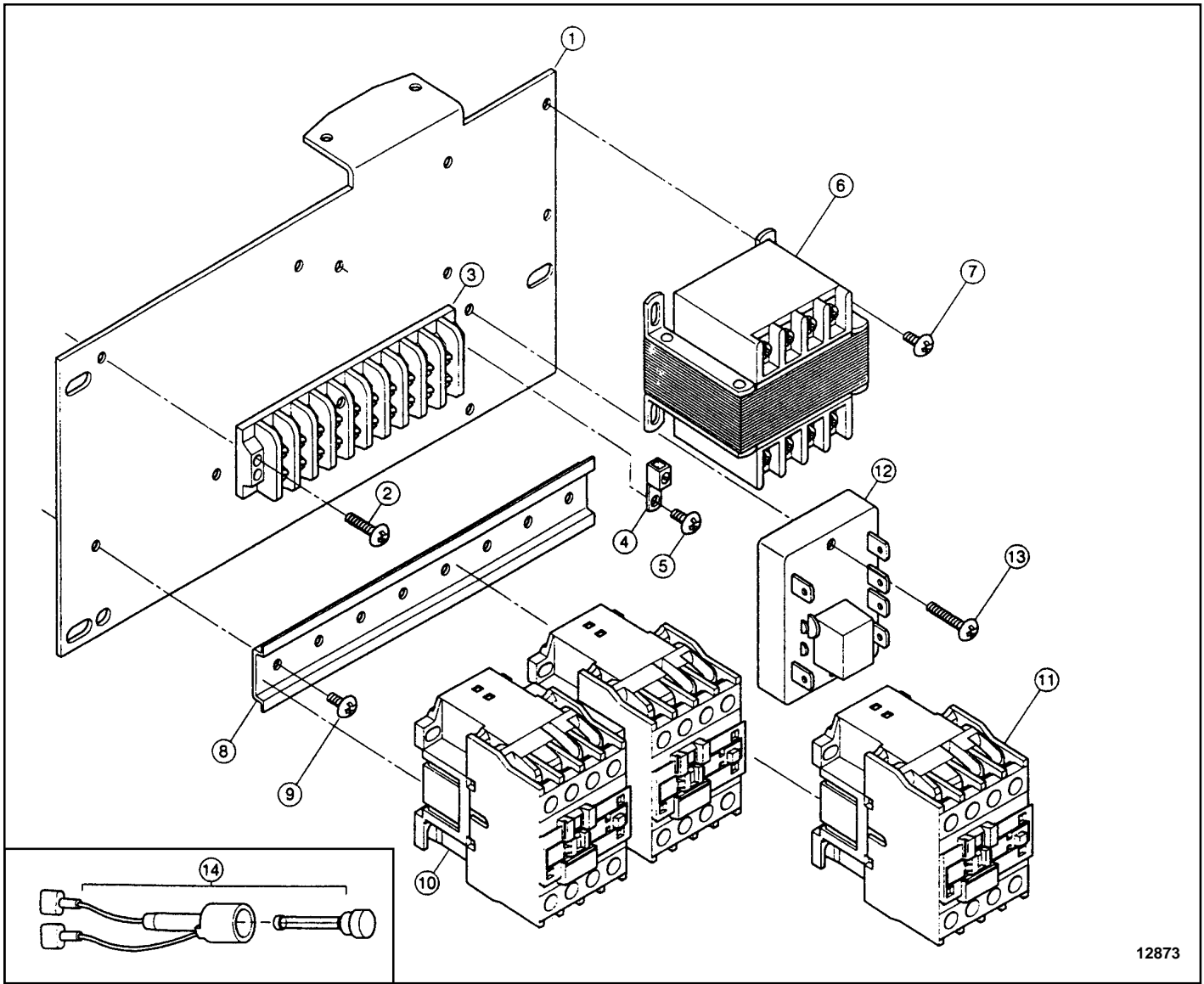

12873

Figure 9-10c. Electrical Control Equipment, Size 2 Hoists (Later Models)

Ref. No.	Part Number	Description	Qty. Req'd
1	700-2300	Mounting Plate For All Except 208V & 230V Hoists with 10 HP Motor or True Vertical Lift Hoist with Plate Width of 21-3/8"	1
	700-2301	For 208V & 230V Hoists with 10 HP Motor Only	
	700-2302	For True Vertical Lift Hoist with Plate Width of 21-3/8" Only	
2	700-2303	Pan Head Machine Screws (#8-32 x 5/8)	2
3	700-2304	Terminal Board	1
4	700-2305	Ground Lug	1
5	700-2306	Pan Head Machine Screws (#10-32 x 1/4)	1
6*		Transformer	1
	700-2307	230/460V Except with 10 HP Motor	
	700-2308	208V Except with 10 HP Motor	
	700-2309	575V	
	700-2310	230/460V with 10 HP Motor	
	700-2311	208V with 10 HP Motor	
		New Transformers	
	700-2326	For 230V 7.5 HP Motor	1
	700-2327	Fuse (1 A)	2
	700-2328	Fuse (6/10A)	1

Figure 9-10c. Electrical Control Equipment. (Continued)

Ref. No.	Part Number	Description	Qty. Req'd
	700-2326	For 460V 5 and 10 HP Motor	1
	700-2329	Fuse (1/2A)	2
	700-2328	Fuse (6/1 OA)	1
	700-2330	For 208V 7.5 HP Motor	1
	700-2327	Fuse (1 A)	2
	700-2328	Fuse (6/10A)	1
	700-2331	For 575V 5 and 10 HP Motor	1
	700-2332	Fuse (1/4A)	2
	700-2328	Fuse (6/1 OA)	1
	700-2333	For 230V 10 HP Motor	1
	700-2334	Fuse (2A)	2
	700-2335	Fuse (1-4/10A)	1
	700-2336	For 208V 10 HP Motor	1
	700-2334	Fuse (2A)	2
	700-2335	Fuse (1-4/10A)	1
7	700-2306	Pan Head Machine Screws (#10-32 x 1/4)	4
8	700-2312	DIN Rail Except for 208V and 230V 10 HP Motor	1
	700-2337	DIN Rail For 208V and 230V 10 HP Motor	1
9	700-2306	Pan Head Machine Screws (#10-32 x 1/4)	3
10		Contactors	1
	700-2313	460V & 575V with 5 HP Motor	
	700-2314	460V & 575V with 10 HP Motor	
	700-2315	208V & 230V with 7.5 HP Motor	
	700-2316	208V & 230V with 10 HP Motor	
11		Contactors - Two Speed Only	1
	700-2317	460V & 575V with 5 HP Motor	
	700-2318	460V & 575V with 10 HP Motor and 208V & 230V with 7.5 HP Motor	
	700-2319	208V & 230V with 10 HP Motor	
12	700-2320	Brake Controller	1
13	700-2321	Pan Head Machine Screws (#8-32 x 7/8)	2
14*		Fuse, Fuse Holder and Wire Assembly	1
	700-2322	For 208V & 230V with 10 HP Motor Only	
	700-2323	Fuse Only (2A, 300V)	
	700-2324	For All Others	
	700-2325	Fuse Only (1A, 300V)	

*Fuse Assembly, Ref. No. 14, has been eliminated and Transformers, Part Numbers 700-2307 thru 700-2310, have been replaced by Transformers with Fuses mounted on the top of the transformer on the latest hoists.

NOTES

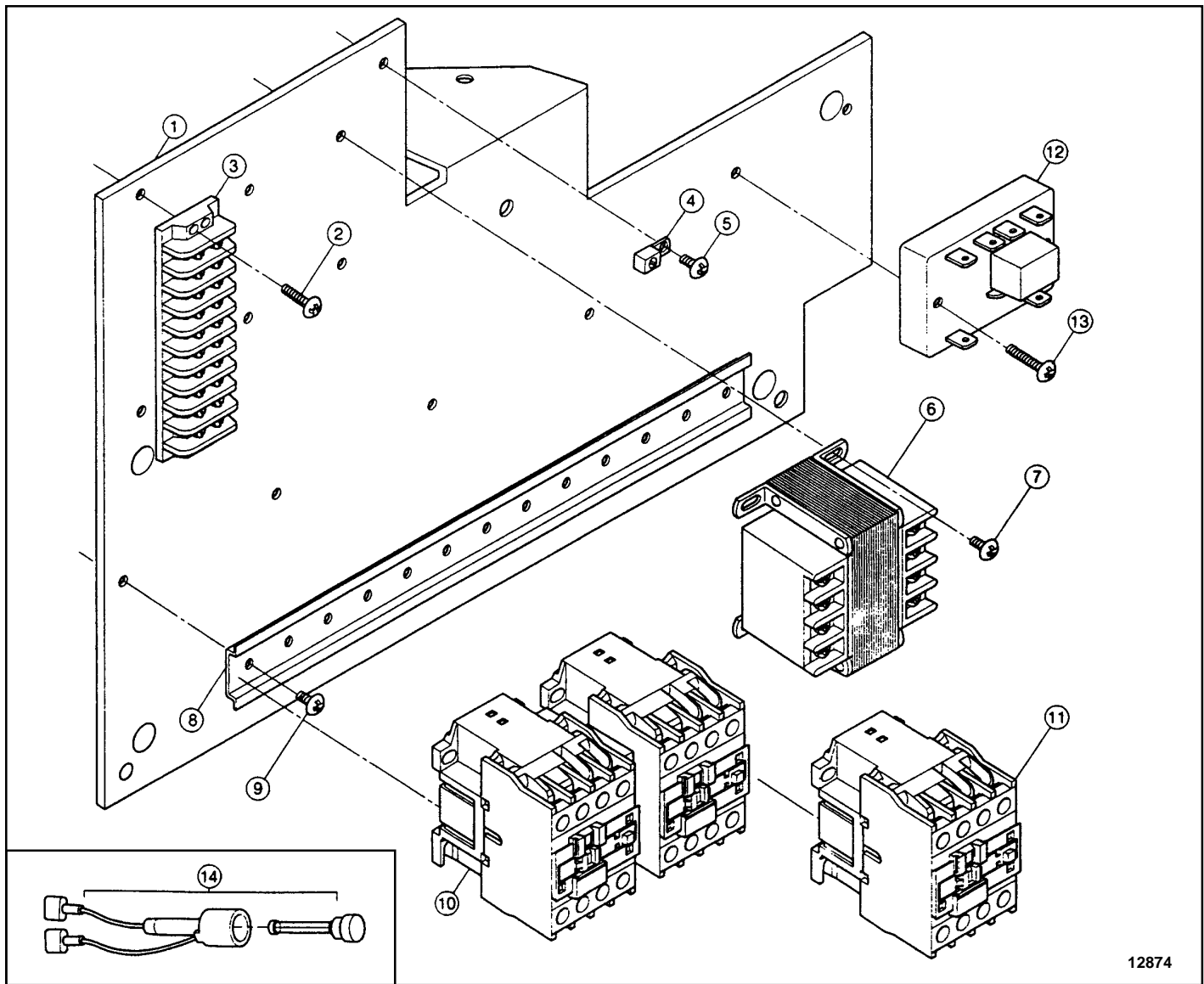
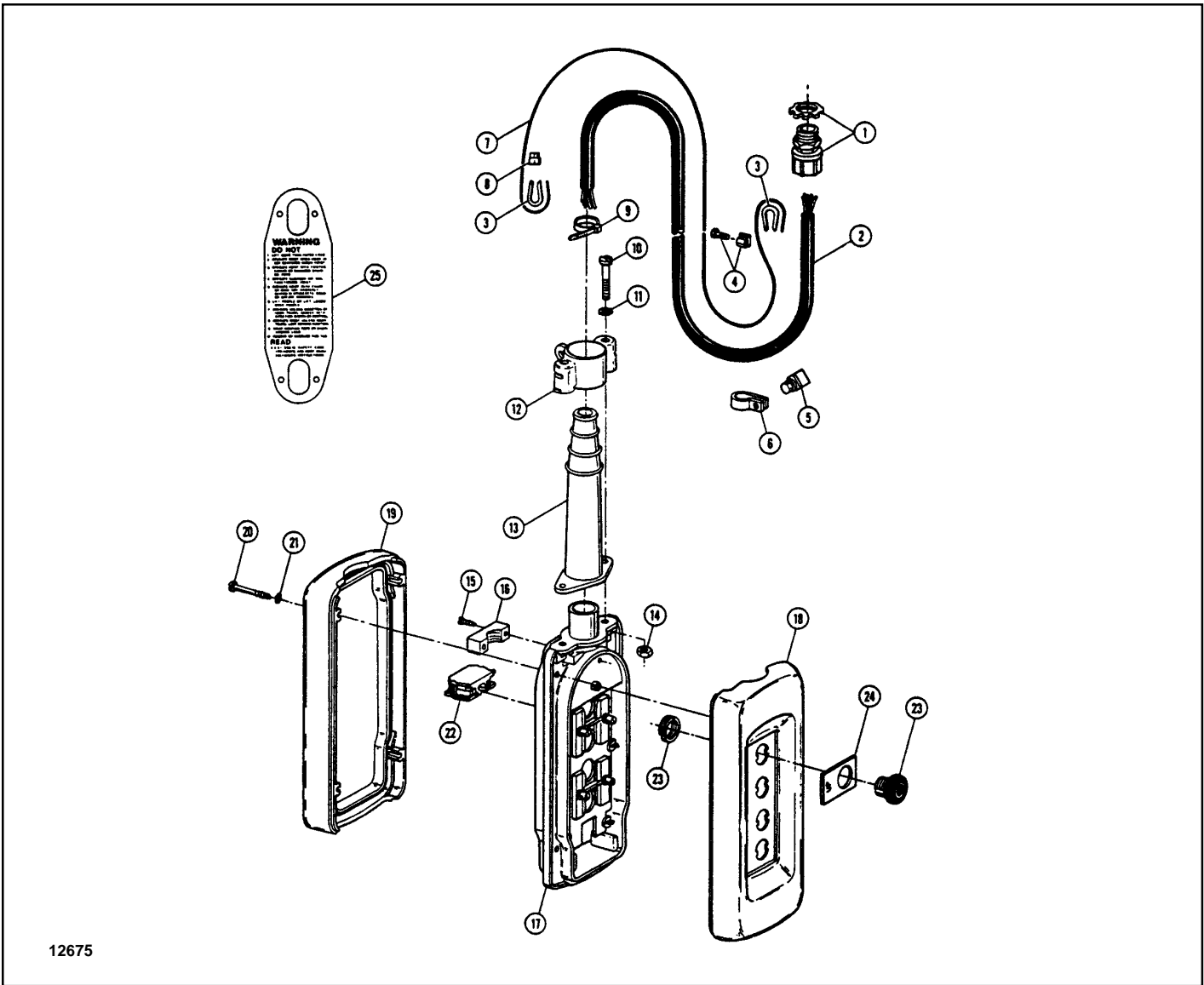

Figure 9-10d. Electrical Control Equipment, Size 3 Hoists (Later Models)

Ref. No.	Part Number	Description	Qty. Req'd
1	700-2400	Mounting Plate	1
2	700-2401	Pan Head Machine Screws (#8-32 x 5/8)	2
3	700-2402	Terminal Board	1
4	700-2403	Ground Lug	1
5	700-2404	Pan Head Machine Screws (#10-32 x 1/4)	1
6*		Transformer	1
	700-2405	230/460V	
	700-2406	208V	
	700-2407	575V	
		New Transformers	
	700-2420	For 230V 7.5 and 15 HP Motor	1
	700-2421	Fuse (2A) '	2
	700-2422	Fuse (1-4/10A)	1
	700-2420	For 460V 10 and 20 HP Motor	1
	700-2423	Fuse (1 A)	2
	700-2422	Fuse (1-4/10A)	1
	700-2424	For 208V 7.5 and 15 HP Motor	1
	700-2421	Fuse (2A)	2
	700-2422	Fuse (1-4/10A)	1



12675

Figure 9-11. Push Button Station and Conductor Cord Assembly

Ref. No.	Part Number	Description	Qty. Req'd
1	700-3100 700-3101 700-3102 700-3103 700-3104	Grip Assembly - Conductor For 4 Conductor Cable For 5 Conductor Cable For 6 Conductor Cable For 7 and 8 Conductor Cable For 10, 12 and 16 Conductor Cable	1
2	700-3105 700-3106 700-3107 700-3108 700-3109 700-3110 700-3111 700-3112	Cable - Flexible Conductor* 4 Conductor 5 Conductor 6 Conductor 7 Conductor 8 Conductor 10 Conductor 12 Conductor 16 Conductor	1
3	700-3113	Thimble - Strain Cable	2
4	700-3114	Connector - Strain Cable	1
5	700-3115	Connector - Conductor to Strain Cable	1

Figure 9-11. Push Button Station and Conductor Cord Assembly (Continued)

Ref. No.	Part Number	Description	Qty. Req'd
6		Clamp - Conductor	1
	700-3116	For 4 Conductor Cable	
	700-3117	For 5 and 6 Conductor Cable	
	700-3118	For 7 Conductor Cable	
	700-3119	For 8 and 10 Conductor Cable	
	700-3120	For 12 Conductor Cable	
	700-3121	For 16 Conductor Cable	
7	700-3122	Cable - Strain*	1
8	700-3123	Sleeve - Pressure	1
		Push Button Assembly (Includes Ref. Nos. 9 thru 24)	1
	700-3124	2 Buttons	3
	700-3125	4 Buttons	3
	700-3126	6 Buttons	3
	700-3127	8 Buttons	3
		Enclosure Assembly (Includes Ref. Nos. 9 thru 21)	1
	700-3128	2 Buttons	3
	700-3129	4 Buttons	3
	700-3130	6 Buttons	3
	700-3131	8 Buttons	3
9	**	Clamp - Conductor	1
10	**	Screw - Slotted Head	2
11	**	Lockwasher	2
12	**	Support - Strain Cable	1
13	700-3132	Sleeve - Conductor	1
14	**	Nut - Hex	2
15	**	Screw - Slotted Head	2
16	**	Clamp - Conductor	1
17	**	Enclosure Body	1
18	**	Enclosure Front	1
19	**	Enclosure Rear	1
20	**	Screw - Slotted Head	
		2 Button Station	2
		4 Button Station	4
		6 Button Station	6
		8 Button Station	8
21	**	Lockwasher	
		2 Button Station	2
		4 Button Station	4
		6 Button Station	6
		8 Button Station	8
22	700-3133	Block - Contact	
		2 Button Station	2
		4 Button Station	4
		6 Button Station	6
		8 Button Station	8
23	700-3134	Push Button Assembly	
		2 Button Station	2
		4 Button Station	4
		6 Button Station	6
		8 Button Station	8
24		Nameplate	1
	700-3135	Stop	
	700-3136	Start	
	700-3137	Up	
	700-3138	Down	
	700-3139	Right	
	700-3140	Left	
25	700-3141	Operator Warning Label	1

* Specify length required.

** Not available separately. Order Enclosure Assembly.

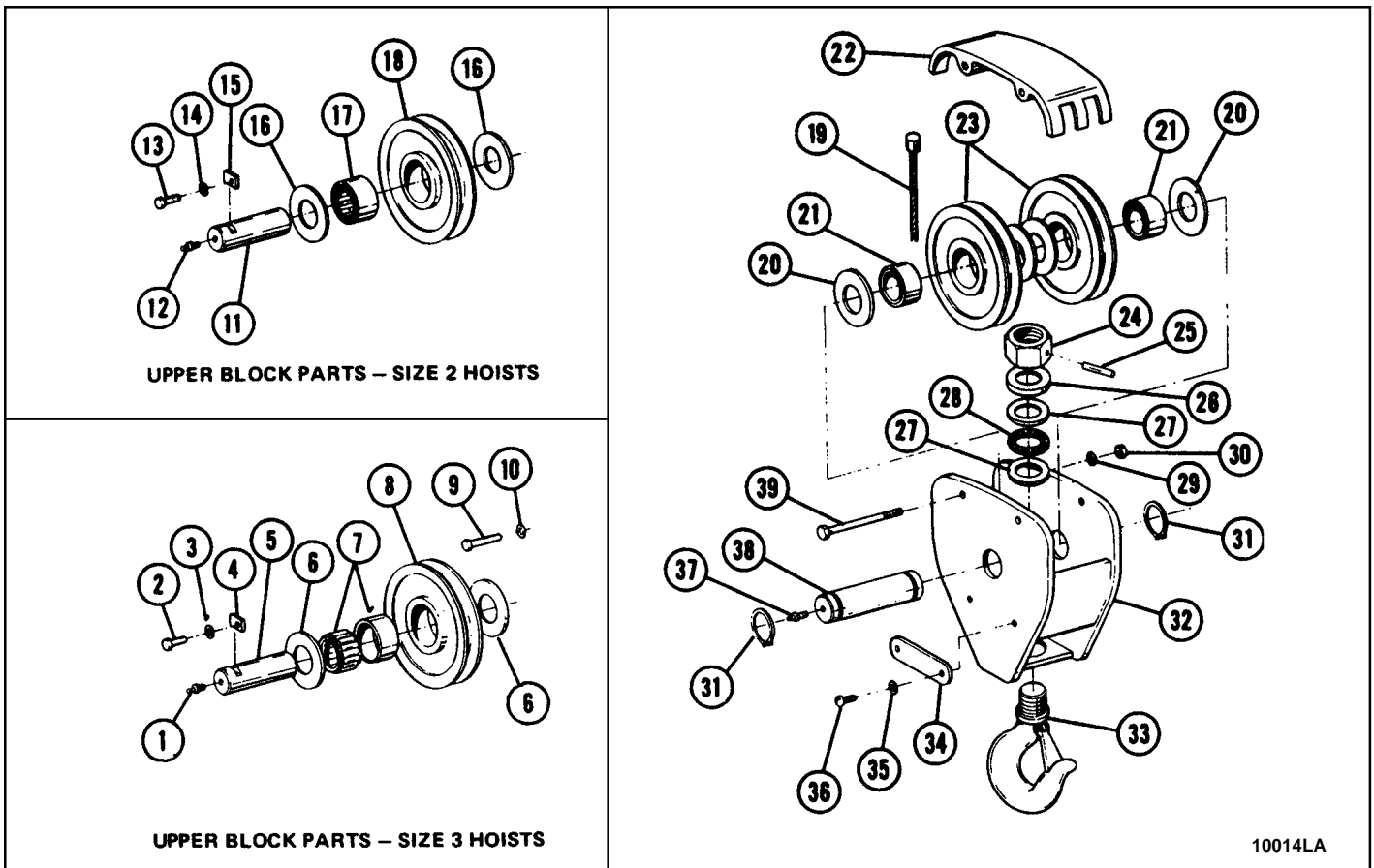

10014LA

Figure 9-14. Upper and Lower Block Parts Including Hoist Rope.
 (2 through 7½ ton - single reeved standard headroom hoist with 1/4" through 7/16" rope)

Ref. No.	Part Number	Description	Quantity Required	
			Reeving	
			2PS	4PS
1	700-1430	Fitting - Grease	-	1
2	700-1431	Screw - Hex Head Cap	-	1
3	700-1432	Lockwasher	-	1
4	700-1433	Key Plate	-	1
5	700-1434	Pin - Upper Sheave	-	1
6	700-1435	Spacer	-	2
7	700-1436	Bearing (includes outer race)	-	1
8	700-1437	Sheave - Upper	-	1
9	700-1438	Bolt - Rope Guide	-	2
10	700-1439	Lockwasher	-	2
11	700-1443	Pin - Upper Sheave	-	1
12	700-1444	Fitting - Grease	-	1
13	700-1402	Screw - Hex Head Cap	-	2
14	700-1403	Lockwasher	-	2
15	700-1404	Key Plate	-	1
16	700-1445	Bushing - Spacer	-	2
17	700-1446	Bearing - Upper Sheave (includes inner race, not shown)	-	1
18	700-1447	Sheave - Upper	-	1
	700-1448	Block Assembly - Lower (Complete)	-	1
	700-1449	Block Assembly - Lower (Complete)	1	-
19†	700-1429	**Rope Assembly - Wire	1	1
20	700-1450	Bushing - Spacer	2	4
21	700-1451	Bearing - Lower Sheave (no inner race)	1	2
22	700-1452	Guard - Sheave	1	1
23	700-1453	Sheave - Lower	1	2
24		Nut- Hook	1	1
25	700-1413	Pin - Roll	1	1

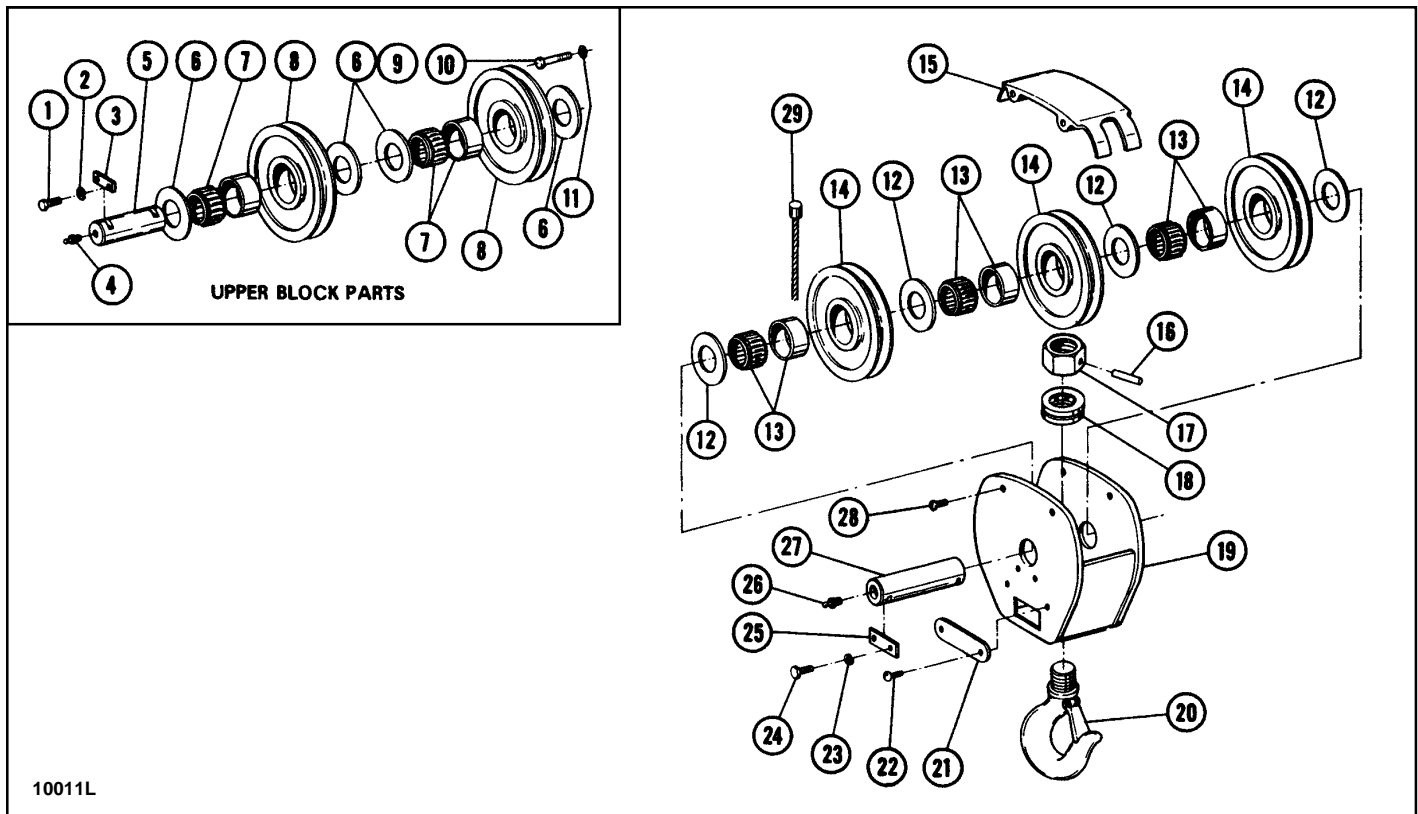

10011L

Figure 9-15. Upper and Lower Block Parts Including Hoist Rope.
 (5 through 15 ton hoists with 9/16" rope and 6 through 10 ton double reeved standard headroom hoists)

Ref. No.	Part Number	Description	Quantity Required				
			Reeving				
			2PS	4PS	6PS	3PD	4PD
1	700-1501	Screw - Hex Head Cap	-	1	1	4	4
2	700-1502	Lockwasher	-	1	1	4	4
3	700-1503	Key Plate	-	1	1	2	2
4	700-1504	Fitting - Grease	-	1	1	1	1
5	700-1505	Pin - Upper Sheave	-	1	1	1	1
6	700-1508	Spacer - Upper Sheave	-	2	4	3	4
7	700-1506	Bearing - Upper Sheave	-	1	2	2	3
8	700-1507	Sheave - Upper	-	1	2	2	3
9	700-1531	Spacer - Upper Sheave (not shown)	-	-	-	2	-
10	700-1532	Bolt - Rope Guide	-	2	2	-	-
11	700-1533	Lockwasher	-	2	2	-	-
	700-1511	Block Assembly - Lower, 2PS (includes Ref. Nos. 12 thru 28)	1	-	-	-	-
	700-1512	Block Assembly - Lower, 4PS (includes Ref. Nos. 12 thru 28)	-	1	-	-	-
	700-1513	Block Assembly - Lower, 6PS (includes Ref. Nos. 12 thru 28)	-	-	1	-	-
	700-1534	Block Assembly - Lower, 3PD (includes Ref. Nos. 12 thru 28)	-	-	-	1	-
	700-1535	Block Assembly - Lower, 4PD (includes Ref. Nos. 12 thru 28)	-	-	-	-	1
12	700-1529	Spacer - Lower Sheave	2	3	4	3	4
13	700-1530	Bearing Assembly (includes outer race)	1	2	3	3	4
14	700-1515	Sheave - Lower	1	2	3	3	4
15	700-1514	Guard - Sheave	1	1	1	1	1
16	700-1516	Pin - Roll	1	1	1	1	1
17	**	Nut - Hook	1	1	1	1	1
18	700-1517	Bearing - Thrust	1	1	1	1	1
19	700-1518	Body - Lower Block	1	1	1	1	1
20	700-1519	Hook - Assembly (includes nut and latch)	1	1	1	1	1
21	700-1527	Plate - Capacity	2	2	2	1	1
22	700-1536	Screw - Round Head, Self-tapping	4	4	4	2	2
23	700-1524	Lockwasher	4	4	4	2	2

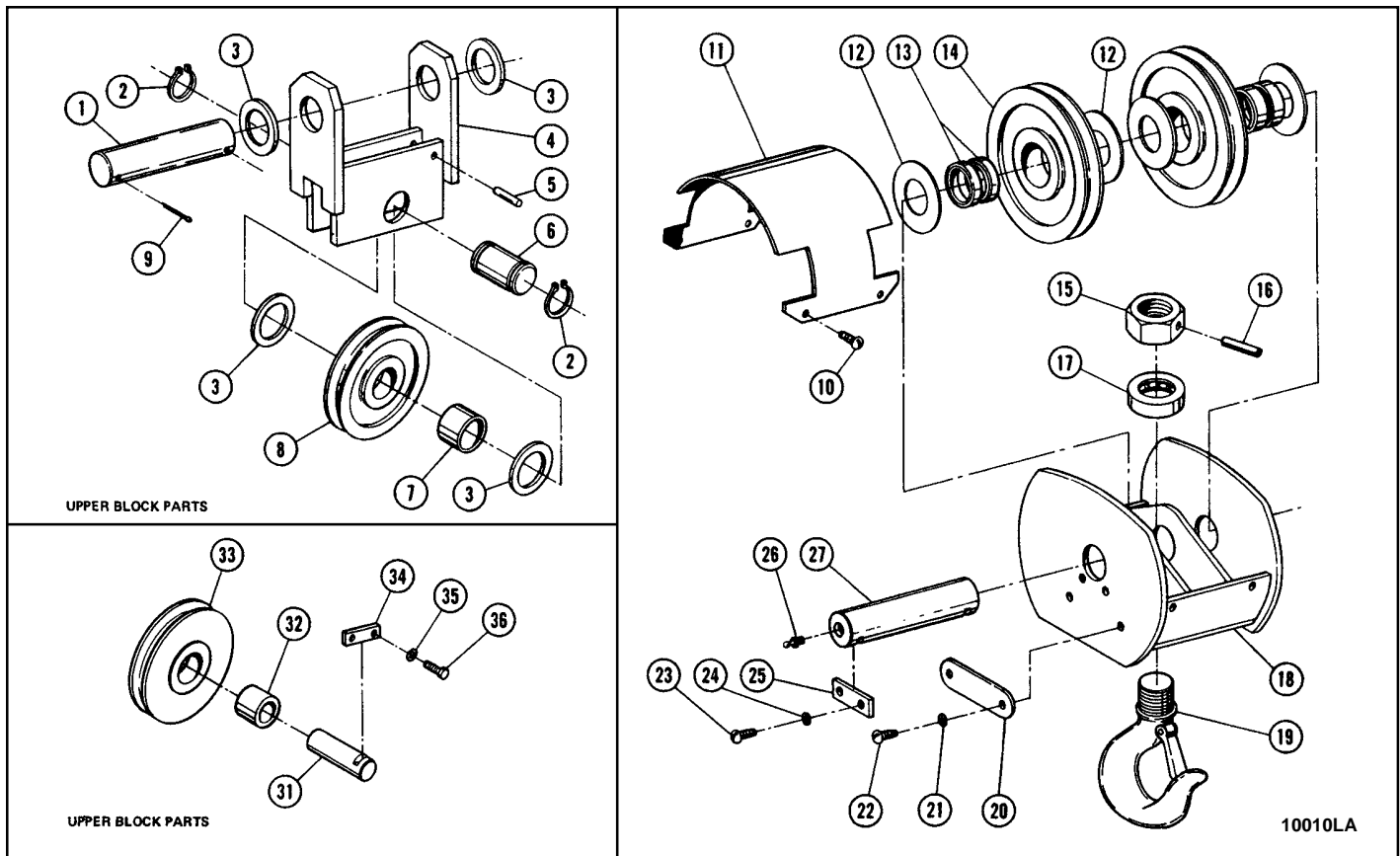

Figure 9-16. Upper and Lower Block Parts Including Hoist Rope.
(2 through 5 ton - standard and low headroom hoists 2PD reeved)

Ref. No.	Part Number	Description	Quantity Required	
			Size 2 Hoist	Size 3 Hoist
1	700-1602	Pin - Upper Sheave Yoke	1	1
2	700-1623	Ring - Retaining	2	2
3	700-1624	Spacer	-	4
4	700-1603	Yoke - Upper Sheave	1	1
5	700-1625	Pin - Drive	2	-
6	700-1604	Pin - Upper Sheave	1	1
7	700-1607	Bearing	1	1
8	700-1606	Sheave - Upper	1	1
9	700-1605	Pin - Cotter	2	2
	700-1608	Block Assembly - Lower (includes Ref. Nos. 10 through 27)	1	1
10	700-1626	Screw - Round Head, Self-tapping	4	4
11	700-1627	Guard - Sheave	1	1
12	700-1628	Spacer	-	4
13	700-1621	Bearing - Sheave	4	2
14	700-1609	Sheave - Lower	2	2
15	**	Nut - Hook	1	1
16	700-1619	Pin - Drive	1	1
17	700-1615	Bearing Assembly - Thrust	1	1
18	700-1638	Body - Lower Block	1	1
19	700-1614	Hook Assembly (includes nut and latch)	1	1
20	700-1617	Plate - Capacity	2	1
21	700-1629	Lockwasher	4	2
22	700-1630	Screw - Self-tapping, Round Head	4	2
23	700-1632	Screw - Hex Head	-	2
24	700-1633	Lockwasher	-	2
25	700-1634	Key Plate	2	1
	700-1645	Ring - Retaining (not shown)	2	-
26	700-1635	Fitting - Grease	-	2
27	700-1616	Pin - Lower Sheave	1	1

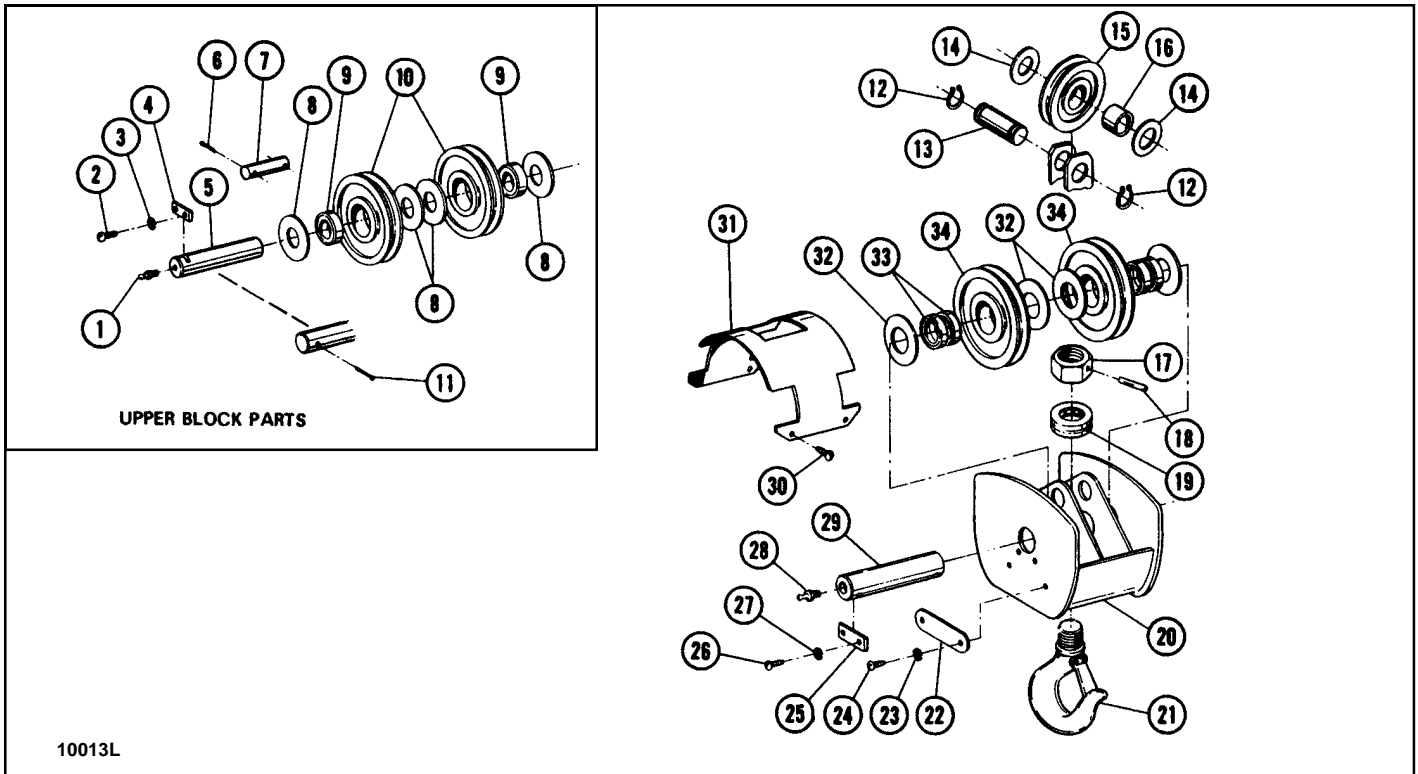

Figure 9-17. Upper and Lower Block Parts Including Hoist Rope.
(2 through 7½ ton low headroom hoists 3PD reeved)

Ref. No.	Part Number	Description	Quantity Required	
			Size 2 Hoist	Size 3 Hoist
1	700-1728	Fitting - Grease	-	2
2	700-1725	Screw - Hex Head	-	2
3	700-1726	Lockwasher	-	2
4	700-1727	Key Plate	-	1
5	700-1702	Pin - Upper Sheave	1	1
6	700-1729	Pin - Cotter	4	4
7	700-1730	Pin - Rope Guide	2	2
8	700-1731	Space - Upper Sheave	-	4
9	700-1703	Bearing - Upper Sheave	4	2
10	700-1704	Sheave - Upper	2	2
11	700-1701	Pin - Cotter	2	-
	700-1742	Block Assembly (includes Ref. Nos. 12 through 34)	1	1
12	700-1732	Ring - Retaining, External	2	2
13	700-1708	Pin - Idler Sheave	1	1
14	700-1733	Spacer - Idler Sheave	-	2
15	700-1706	Sheave - Idler	1	1
16	700-1707	Bearing - Idler Sheave	1	1
17	**	Nut - Hook	1	1
18	700-1722	Pin - Drive	1	1
19	700-1718	Bearing - Thrust	1	1
20	700-1746	Body Assembly - Lower Block	1	1
21	700-1716	Hook Assembly (includes nut and hook latch)	1	1
22	700-1720	Plate - Capacity	2	1
23	700-1734	Lockwasher	4	2
24	700-1721	Screw - Round Head, Self-tapping	4	2
25	700-1737	Key Plate	2	1
26	700-1735	Screw - Round Head, Machine	4	-
	700-1736	Screw - Hex Head Cap	-	2
27	700-1738	Lockwasher	4	2
28	700-1739	Fitting - Grease	-	2
29	700-1719	Pin - Lower Sheave	1	1
30	700-1740	Screw - Round Head, Self-tapping	4	4

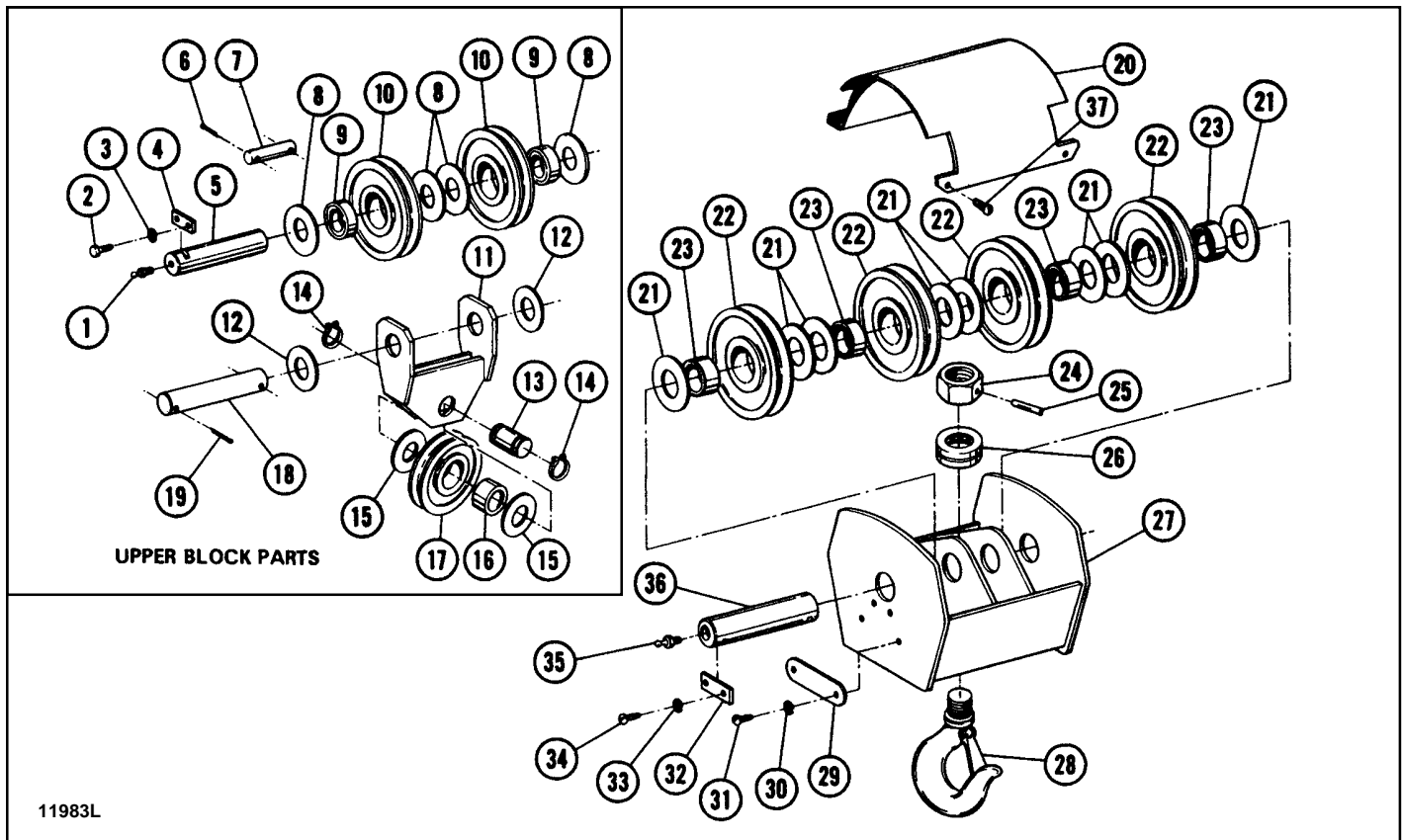

Figure 9-18. Upper and Lower Block Parts Including Hoist Rope.
(10 ton low headroom hoists)

Ref. No.	Part Number	Description	Qty. Req'd
1	700-1801	Fitting - Grease	2
2	700-1802	Screw - Hex Head Cap	2
3	700-1803	Lockwasher	2
4	700-1804	Key Plate	1
5	700-1805	Pin - Upper Sheave	1
6	700-1906	Pin - Cotter	4
7	700-1807	Pin - Rope Guide	2
8	700-1808	Spacer - Upper Sheave	4
9	700-1909	Bearing - Upper Sheave	2
10	700-1810	Sheave - Upper	2
11	700-1811	Yoke Assembly - Equalizer	1
12	700-1812	Spacer - Equalizer Yoke Pin	2
13	700-1813	Pin - Equalizer Sheave	1
14	700-1814	Ring - Retaining	2
15	700-1815	Spacer - Equalizer Sheave	2
16	700-1816	Bearing - Equalizer Sheave	1
17	700-1817	Sheave - Equalizer Yoke	1
18	700-1818	Pin - Equalizer Yoke	1
19	700-1819	Pin - Cotter	2
	700-1820	Lower Block Assembly (includes Ref. Nos. 20 through 37)	1
20	700-1821	Guard - Sheave	1
21	700-1822	Spacer - Lower Sheave	6
22	700-1823	Sheave - Lower	4
23	700-1824	Bearing - Lower Sheave	4
24	**	Nut - Hook	1
25	700-1825	Pin - Drive	1
26	700-1826	Bearing - Thrust	1
27	700-1827	Body Assembly - Lower Block	1
28	700-1828	Hook Assembly (includes nut and hook latch)	1
29	700-1829	Plate - Capacity	1

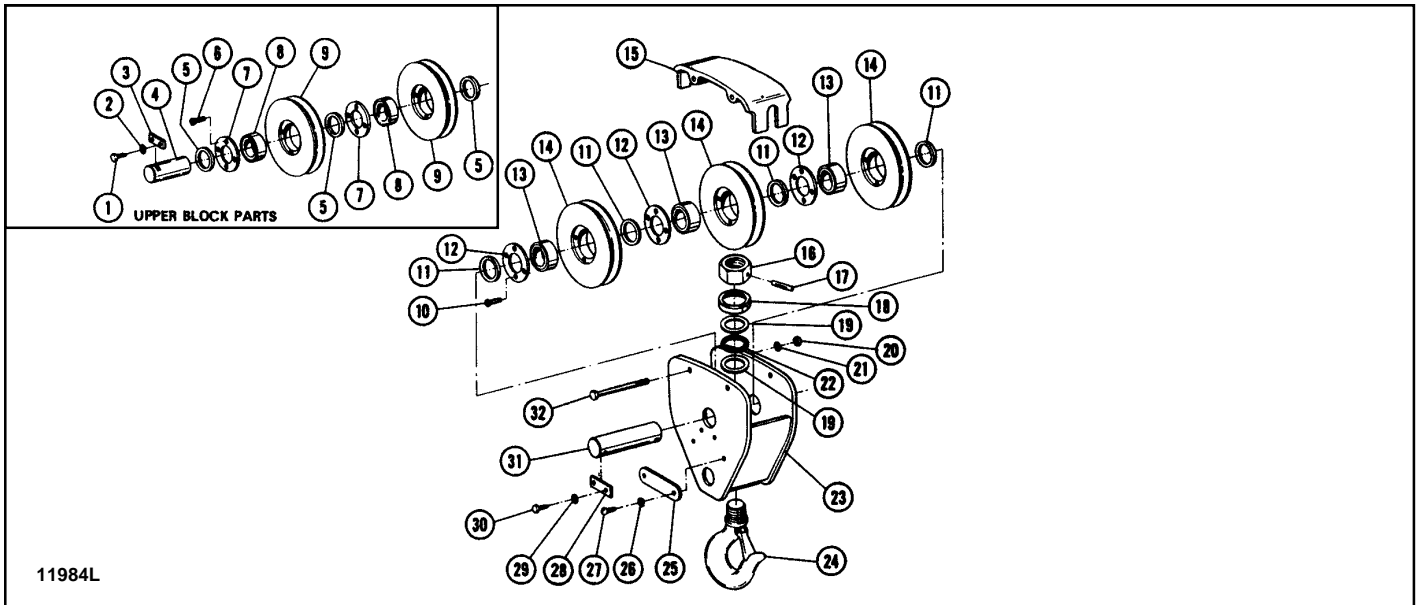

Figure 9-19. Upper and Lower Block Parts Including Hoist Rope.
(7½ ton standard headroom hoists)

Ref. No.	Part Number	Description	Qty. Req'd
1	700-1910	Screw - Hex Head Cap	2
2	700-1902	Lockwasher	2
3	700-1903	Key Plate	1
4	700-1904	Pin - Upper Sheave	1
5	700-1905	Spacer - Upper Sheave	3
6	700-1906	Screw - Flat Head Socket, Self-locking	8
7	700-1907	Plate - Retainer, Bearing	2
8	700-1908	Bearing - Upper Sheave	2
9	700-1909	Sheave	2
	700-1910	Lower Block Assembly (includes Ref. Nos. 10 through 32)	1
10	700-1911	Screw - Flat Head Socket, Self-locking	12
11	700-1912	Spacer - Lower Sheave	4
12	700-1913	Plate - Retaining Bearing	3
13	700-1914	Bearing - Lower Sheave	3
14	700-1915	Sheave - Lower	3
15	700-1916	Guard - Sheave	1
16	**	Nut - Hook	1
17	700-1917	Pin - Drive	1
18	700-1918	Shield - Bearing	1
19	700-1919	Washer - Thrust	2
20	700-1920	Nut - Hex	2
21	700-1921	Lockwasher	2
22	700-1922	Bearing - Thrust	1
23	700-1923	Body Assembly - Lower Block	1
24	700-1924	Hook Assembly (includes nut and hook latch)	1
25	700-1925	Plate - Capacity	2
26	700-1926	Lockwasher	4
27	700-1927	Screw - Round Head, Self-tapping	4
28	700-1928	***Key Plate	2
29	700-1929	***Lockwasher	4
30	700-1930	***Screw - Hex Head Cap	4
31	700-1931	***Pin - Lower Sheave	1
32	700-1932	Bolt - Hex Head	2
33†	700-1933	*Rope Assembly - Wire (not shown)	1

* CAUTION: Only factory approved wire rope assembly of proper length, having swagged fittings, one at each end, should be used for replacement. Do not use substitutes.

** Hook nuts are not interchangeable; available only as an assembly.

*** Later Model hoists use pin (700-1935) with two retaining rings (700-1934).

† Recommended spares.

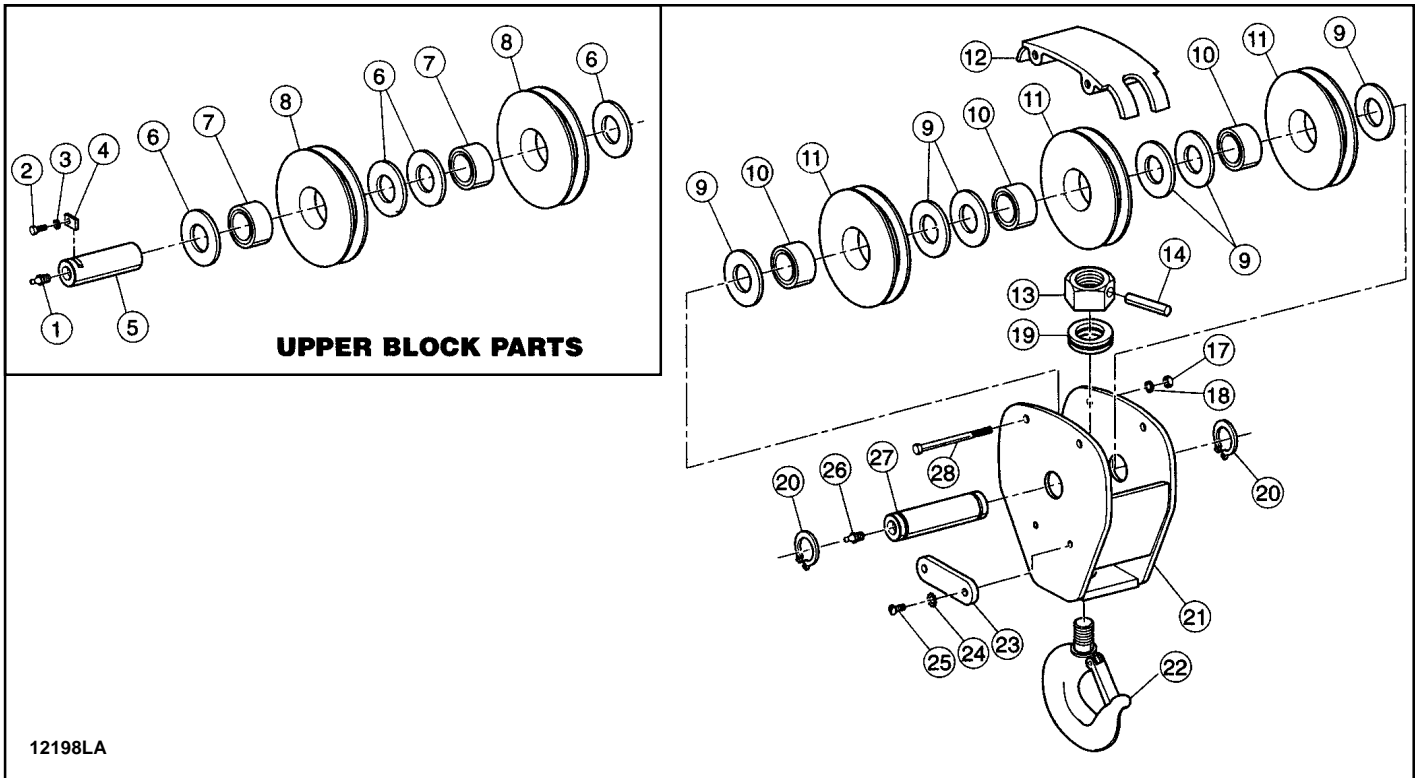

**Figure 9-20. Upper and Lower Block Parts Including Hoist Rope.
(10 ton size 2, 6 part single reeved standard headroom hoists)**

Ref. No.	Part Number	Description	Qty. Req'd
1	700-2001	Fitting - Grease	1
2	700-2002	Screw - Hex Head Cap	1
3	700-2003	Lockwasher	1
4	700-2004	Key Plate	1
5	700-2005	Pin - Upper Sheave	1
6	700-2006	Washer - Spacer, Upper Sheave	4
7	700-2007	Bearing- Upper Sheave	2
8	700-2008	Sheave - Upper	2
	700-2000	Block Assembly - Lower (includes Ref. Nos. 9 through 28)	1
9	700-2009	Washer - Spacer, Lower Sheave	6
10	700-2010	Bearing - Lower Sheave	3
11	700-2011	Sheave - Lower	3
12	700-2012	Guard - Lower Sheave	1
13	**	Nut - Hook	1
14	700-2014	Roll Pin - Hook Nut	1
17	700-2017	Nut - Hex (sheave guard)	2
18	700-2018	Lockwasher (sheave guard)	2
19	700-2019	Bearing - Thrust	1
20	700-2020	Retaining Ring - External (sheave pin)	2
21	700-2021	Body - Lower Block	1
22	700-2022	Hook Assembly (includes nut, roll pin, hook and safety latch)	1
23	700-2023	Plate - Capacity	2
24	700-2024	Lockwasher	4
25	700-2025	Screw - Round Head, Self-tapping	4
26	700-2026	Fitting - Grease	1
27	700-2027	Pin - Lower Sheave	1
28	700-2028	Bolt - Hex Head	2
29t	700-2013	*Rope Assembly - Wire (not shown)	1

* CAUTION: Only factory approved wire rope assembly of proper length, having swagged fittings, one at each end, should be used for replacement. Do not use substitutes.

** Hook nuts are not interchangeable; available only as an assembly.

† Recommended spares.

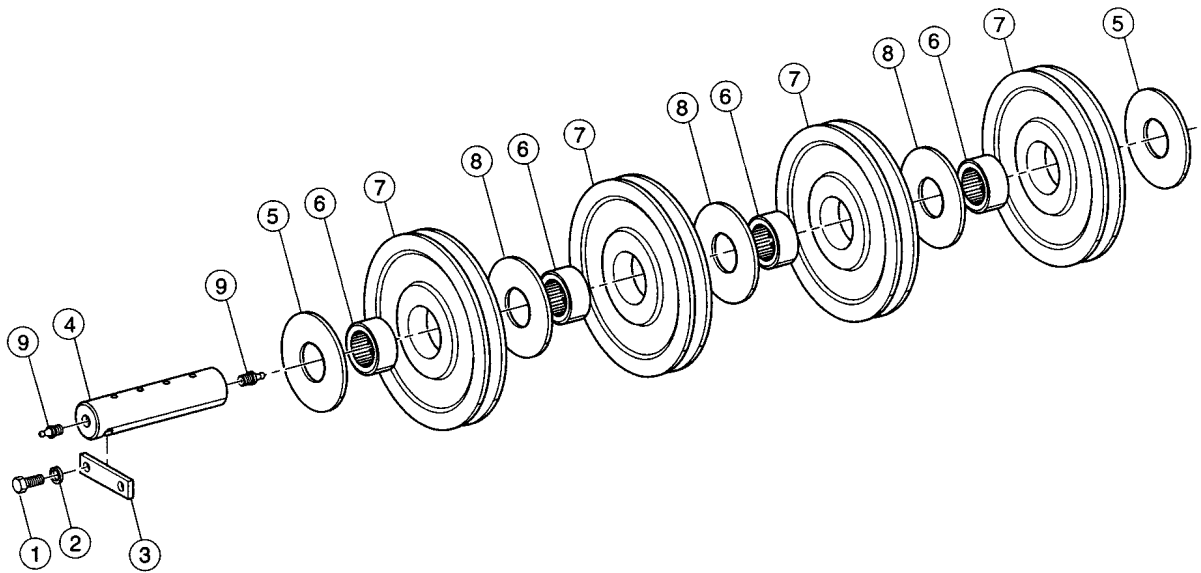

UPPER BLOCK PARTS

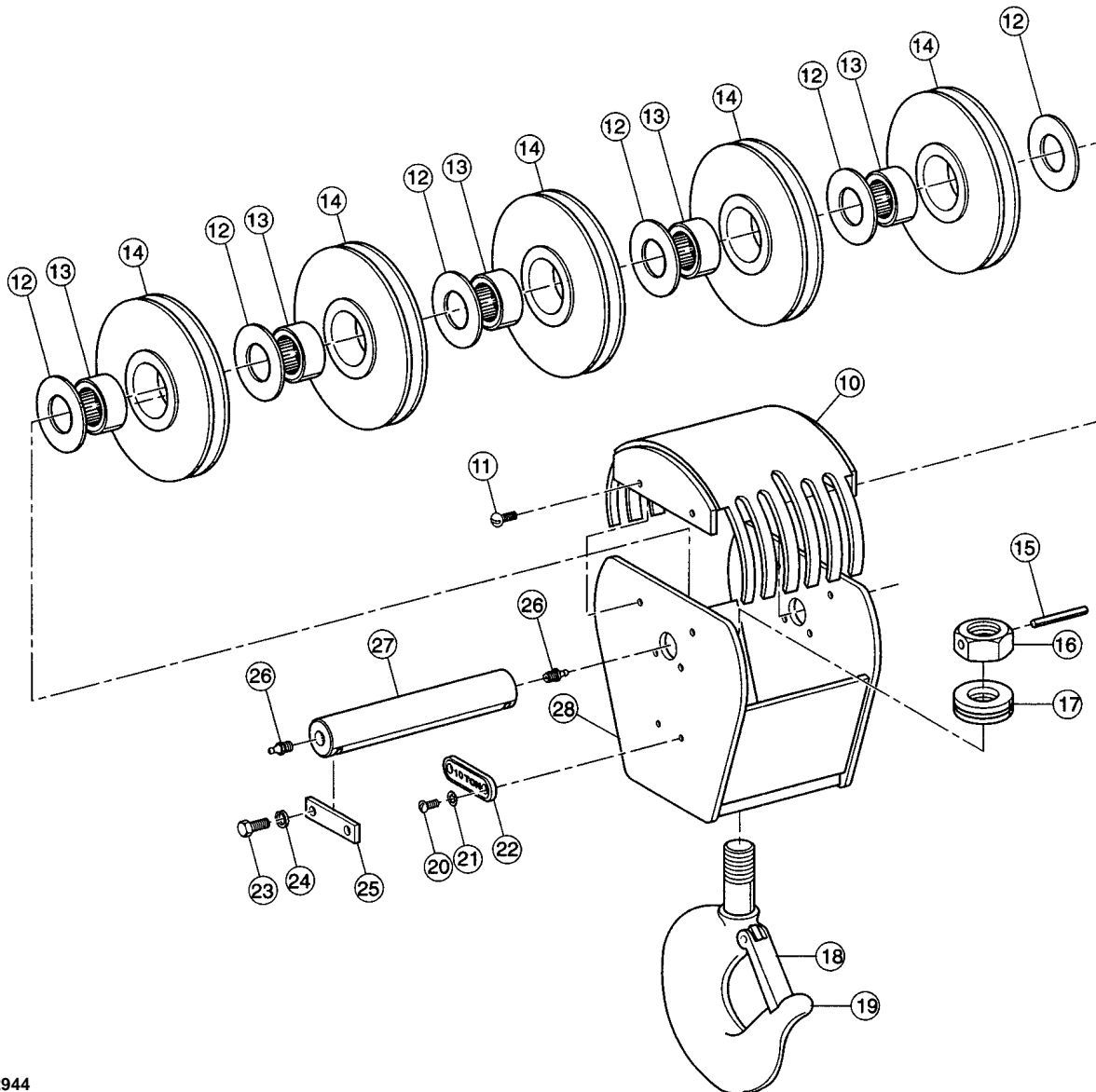

12944

Figure 9-20a. Upper and Lower Block Parts Including Hoist Rope.
(10 ton size 2, 5 part double reeved standard headroom hoists)

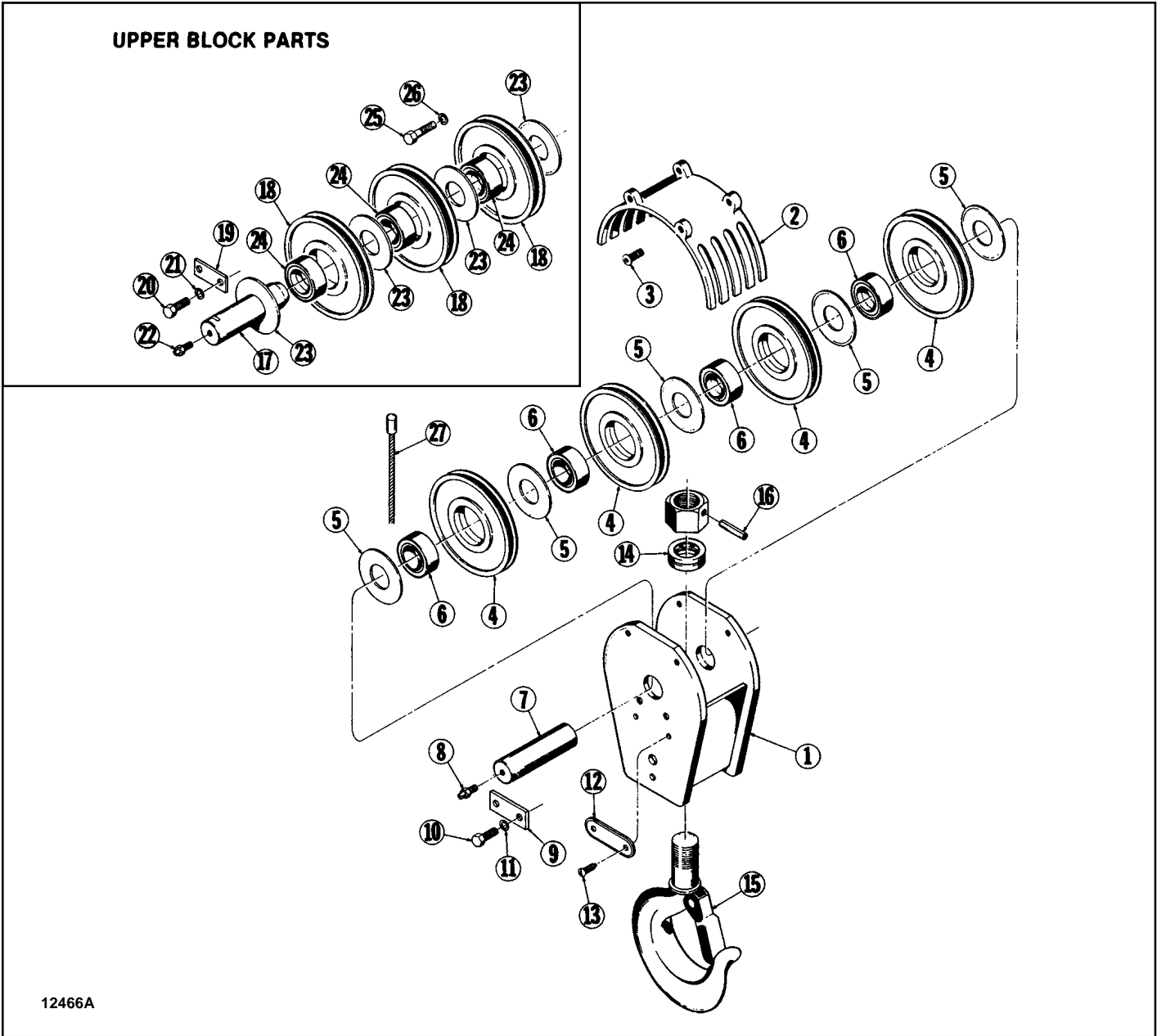

12466A

Figure 9-21. Upper and Lower Block Parts Including Hoist Rope.
(20 and 25 ton - single reeved standard headroom hoist with 1/2" and 9/16" rope)

Ref. No.	Part Number	Description	Quantity Required	
			For 20 Ton	For 25 Ton
	700-2100	Lower Block Assembly (includes Ref. Nos. 1 through 16)	1	-
	700-2101	Lower Block Assembly (includes Ref. Nos. 1 through 16)	-	1
1	700-2102	Body - Lower Block	1	1
2	700-2103	Guard - Sheave	1	1
3	700-2104	Cap Screw - Hex Socket Head	4	4
4	700-2105	Sheave - Lower	4	-
	700-2106	Sheave - Lower	-	4
5	700-2107	Spacer - Lower Sheave	5	5
6	700-2108	Bearing - Lower Sheave	4	4
7	700-2109	Pin - Lower Sheave	1	1
8	700-2110	Fitting - Grease	2	2
9	700-2111	Key Plate	1	1
10	700-2112	Screw - Hex Head Cap	2	2

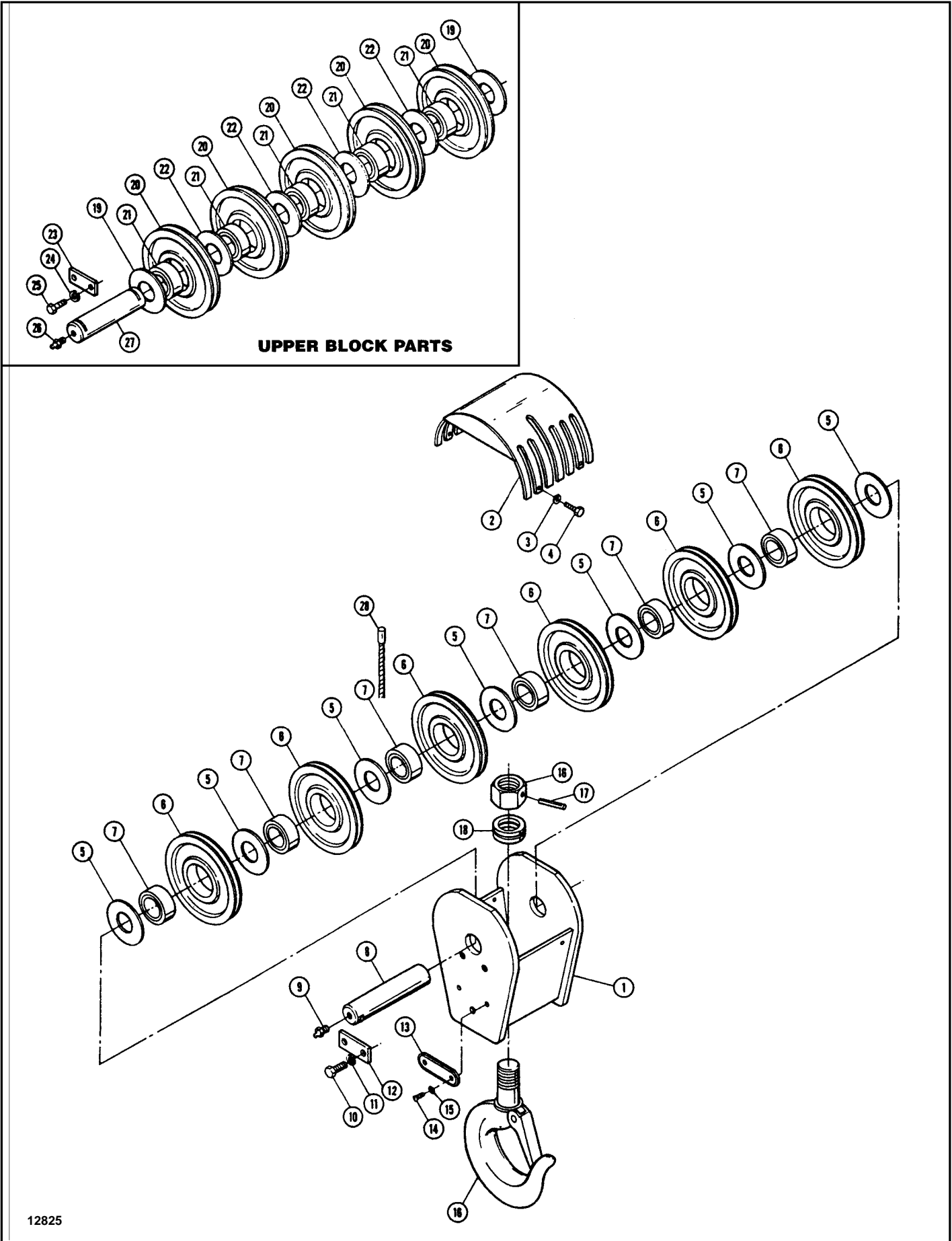

Figure 9-22. Upper and Lower Block Parts Including Hoist Rope.
 (15 and 20 ton - double reeved hoist with 7/16" rope)

Figure 9-22. Upper and Lower Block Parts Including Hoist Rope. (Continued)

Ref. No.	Part Number	Description	Quantity Required	
			For 20 Ton	For 25 Ton
1	700-2200	Lower Block Assembly (includes Ref. Nos. 1 thru 18)	1	-
	700-2201	Lower Block Assembly (includes Ref. Nos. 1 thru 18)	-	1
2	700-2202	Body - Lower Block	1	-
	700-2203	Body - Lower Block	-	1
3	700-2204	Guard - Sheave	1	1
4	700-2205	Lockwasher	4	4
5	700-2206	Bolt - Hex Head	4	4
6	700-2207	Spacer	7	7
7	700-2208	Sheave	6	6
8	700-2209	Bearing	6	6
9	700-2210	Pin - Sheave	1	1
10	700-2211	Fitting - Grease	2	2
11	700-2212	Bolt - Hex Head	2	2
12	700-2213	Lockwasher	2	2
13	700-2214	Key Plate	1	1
14	700-2215	Plate - Capacity	1	-
	700-2216	Plate - Capacity	-	1
15	700-2217	Machine Screw - Round Head	2	2
16	700-2218	Lockwasher	2	2
17	700-2219	Hook Assembly (includes hook, nut, roll pin & latch)	1	-
	700-2220	Hook Assembly (includes hook, nut, roll pin & latch)	-	1
18	700-2221	Roll Pin	1	-
	700-2222	Roll Pin	-	1
19	700-2223	Bearing - Thrust	1	-
	700-2224	Bearing - Thrust	-	1
20	700-2225	Spacer	2	2
21	700-2226	Sheave	5	5
22	700-2227	Bearing	5	5
23	700-2228	Spacer	4	4
24	700-2229	Key Plate	2	2
25	700-2230	Lockwasher	4	4
26	700-2231	Bolt - Hex Head	4	4
27	700-2232	Fitting - Grease	1	1
28†	700-2233	Pin - Sheave	1	1
		*Rope Assembly - Wire		
	700-2234	16' Lift	1	-
	700-2235	26' Lift	1	-
	700-2236	36' Lift	1	-
	700-2237	56' Lift	1	-
	700-2238	20' Lift	-	1
	700-2239	27' Lift	-	1

* CAUTION: Only factory approved wire rope assembly of proper length, having swagged fittings, one at each end, should be used for replacement. Do not use substitutes.

† Recommended spares.

Note: Hook nuts are not interchangeable; available only as an assembly.

NOTES

Recommended Spare Parts for Your Shaw-Box Hoist

Certain parts of your hoist will, in time, require replacement under normal wear conditions. It is suggested that the following parts be purchased for your hoist as spares for future use.

- One set of load brake friction washers
- One set of motor brake washer and lining assemblies
- One set of motor brake plates
- One set of motor brake release springs
- One motor brake actuator spring
- One brake controller
- One gearcase cover gasket
- One brake cover gasket
- One set of contactors
- One transformer
- One wire rope assembly

Note: When ordering parts always furnish Hoist Serial Number, Catalog Number, Motor Horsepower, Voltage, Phase, Frequency and Rated Load of Hoist on which the parts are to be used.

Parts for your hoist are available from your local authorized **Shaw-Box** repair station. For the location of your nearest repair station, write:

IN USA

Yale•Lift-Tech

P.O. Box 769

Muskegon, MI 49443-0769

Phone: **800 742-9269**

Fax: **800 742-9270**

WARRANTY

WARRANTY AND LIMITATION OF REMEDY AND LIABILITY

A. Seller warrants that its products and parts, when shipped, and its work (including installation, construction and start-up), when performed, will meet applicable specifications, will be of good quality and will be free from defects in material and workmanship. All claims for defective products or parts under this warranty must be made in writing immediately upon discovery and in any event, within one (1) year from shipment of the applicable item unless Seller specifically assumes installation, construction or start-up responsibility. All claims for defective products or parts when Seller specifically assumes installation, construction or start-up responsibility and all claims for defective work must be made in writing immediately upon discovery and in any event, within one (1) year from completion of the applicable work by Seller, provided; however, all claims for defective products and parts made in writing no later than eighteen (18) months after shipment. Defective items must be held for Seller's inspection and returned to the original f.o.b. point upon request. THE 'FOREGOING IS EXPRESSLY IN LIEU OF ALL OTHER WARRANTIES WHATSOEVER, EXPRESS, IMPLIED AND STATUTORY, INCLUDING, WITHOUT LIMITATION, THE IMPLIED WARRANTIES OF MERCHANTABILITY AND FITNESS.

B. Upon Buyer's submission of a claim as provided above and its substantiation, Seller shall at its option either (i) repair or replace its product, part or work at either the original f.o.b. point of delivery or at Seller's authorized service station nearest Buyer or (ii) refund an equitable portion of the purchase price.

C. This warranty is contingent upon Buyer's proper maintenance and care of Seller's products, and does not extend to normal wear and tear. Seller reserves the right to void warranty in event of Buyer's use of inappropriate materials in the course of repair or maintenance, or if Seller's products have been dismantled prior to submission to Seller for warranty inspection.

D. The foregoing is Seller's only obligation and Buyer's exclusive remedy for breach of warranty and is Buyer's exclusive remedy hereunder by way of breach of contract, tort, strict liability or otherwise. In no event shall Buyer be entitled to or Seller liable for incidental or consequential damages. Any action for breach of this agreement must be commenced within one (1) year after the cause of action has accrued.

SHAW-BOX®