

LEVER HOIST



Features

Standard Overload Protection – Overload device is set at approximately 150% of the rated load. This feature prevents the hoist from being severely overloaded causing damage to the hoist.

Free Wheel Feature – When not under load, the operator can disengage the gearing by positioning the selection switch to the center position. This allows for a quick adjustment of chain for faster operation.

Lifting or Pulling – Can be used for lifting or pulling which makes it a more versatile tool.

Minimal Load Lifting Effort – Double reduction gearing provides easy operation with minimal lifting effort.

360-Degree Handle Rotation – Allows the operator to work in confined spaces.

All-Steel Construction – Featuring a long lasting powder coat finish, the all-steel construction ensures durable protection while providing a long and dependable service life in harsh environments.

Weston-Style Brake System – An enclosed and protected Weston-Style load brake stays clean and dry during the entire load operation. Also equipped with a unique twin pawl design for additional reliability.

Enclosed Gearing – Gears are protected from contamination and debris.

Fully-Enclosed Lift Wheel – Maintains smooth operation while distributing the load over more links of chain. It also helps keep debris from contaminating the lift wheel and self-cleans the chain as it enters the wheel.

Sealed Roller Bearing – This feature provides smooth, controlled operation of the gears and shafts. This ensures maintenance-free lubrication.

Steel Handle with Rubber Grip – Provides a non-slip, sure-grip surface.

Forged Hooks – Forged alloy steel hooks swivel 360° for easier attachment and positioning.

Cast steel safety latches – Heavy-duty, cast-steel safety latch has a bolt-and-lock nut connection. This feature simplifies changing latches in the field.

100% load tested Zinc-Plated Chain – Provides a durable non-oily finish.

Stainless Steel Riveted ID Tags – Made from stainless steel the ID tag is corrosion resistant.

Maintenance – Hoists can be quickly disassembled for fast and easy maintenance. See the videos and maintenance breakdown animations at OZLiftingProducts.com.

***Safety Hooks & Shipyard Hooks available for 1.5 and 3 Ton Lever Hoists**

Standards – CE, ASME B30.21, AS1418.2



OVERLOAD PROTECTED

OZ075LHOP



.75, 1.5, 3 T

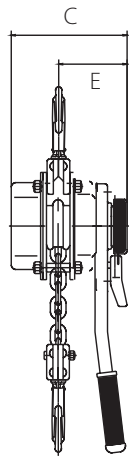
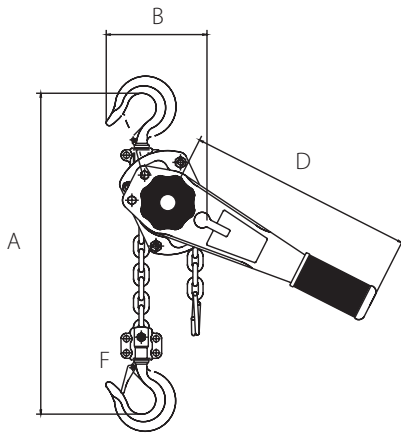

OZ600LHOP



6 T

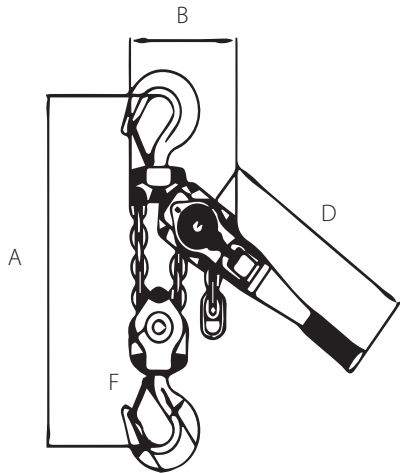

9 T

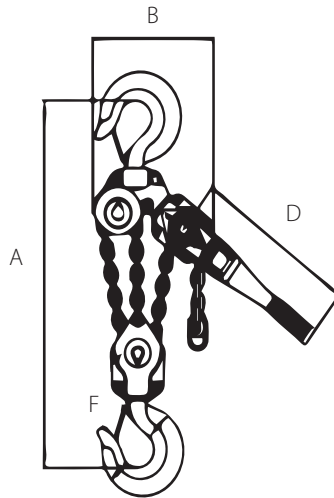

	OZ075-LHOP	OZ150-LHOP	OZ300-LHOP	OZ600-LHOP	OZ900-LHOP	
Capacity (tons)	0.75	1.5	3	6	9	
Headroom (in)	12.79	14.96	18.90	24.41	27.56	
Effort on lever to lift full load (lbs)	30.86	48.50	70.55	74.96	79.37	
Falls of Chain	1	1	1	2	3	
Diameter of Load Chain (mm)	6	8	10	10	10	
Length of Lever Handle (in)	11.02	16.14	16.14	16.14	16.14	
Dimensional Information (in)	A	12.79	14.96	18.89	27.55	
	B	5.35	6.29	7.08	9.25	12.44
	C	5.82	6.77	7.87	7.87	7.87
	D	11.02	16.14	16.14	16.14	16.14
	E	3.54	3.85	4.52	4.52	4.52
Hook-opening, Upper & Lower (in)	F	1.18	1.41	1.57	1.96	2.28
Net Weight of Head Only (lbs)	13	22	33	51	81	

***Standard Lift: 5,10,15, and 20 ft.**

We also do custom rigging

*Dimensions are for reference only and subject to change without notice.

