

# Electrification 8-Bar Conductor Bar System

---

Electrification 8-Bar Instruction Manual



**MAGNETEK**  
MATERIAL HANDLING

Part Number: 005-1044-R9

October 2019

© Copyright 2019 Magnetek Material Handling

**Page Intentionally Left Blank**

## Service Contact Information

For questions regarding service or technical information contact:

1-866-MAG-SERV  
(1-866-624-7378)

Magnetek Material Handling  
N49 W13650 Campbell Drive  
Menomonee Falls, WI 53051

**Telephone:** 800-288-8178

**Website:** [www.magnetekmh.com](http://www.magnetekmh.com)

**E-mail:** [info@magnetekmh.com](mailto:info@magnetekmh.com)

**Fax Numbers:**

Main: 800-298-3503

Sales: 262-783-3510

Service: 262-783-3508

Magnetek, Inc. has additional satellite locations for Canada and the United States. For more information, please visit <http://www.magnetek.com>.

©2019 MAGNETEK

All rights reserved. This notice applies to all copyrighted materials included with this product, including, but not limited to, this manual and software embodied within the product. This manual is intended for the sole use of the person(s) to whom it was provided, and any unauthorized distribution of the manual or dispersal of its contents is strictly forbidden. This manual may not be reproduced in whole or in part by any means whatsoever without the expressed written permission of MAGNETEK.

**Table of Contents**

Chapter 1.0: Warnings and Cautions ..... 5  
Chapter 2.0: Disconnecting Means/Overcurrent Protection ..... 6  
Chapter 3.0: Assembly Guidelines ..... 9  
Chapter 4.0: Conductor Application and Support Spacing ..... 12  
Chapter 5.0: Mounting Brackets ..... 13  
Chapter 6.0: Hanger Assembly ..... 15  
Chapter 7.0: Joint Keeper Installation – For Copper Conductors Only ..... 16  
Chapter 8.0: Joint Covers ..... 17  
Chapter 9.0: Expansion Sections ..... 18  
Chapter 10.0: Transfer Caps ..... 21  
Chapter 11.0: Collectors ..... 22  
Chapter 12.0: Final Inspection ..... 27  
Chapter 13.0: Special Applications and Field Instructions ..... 28

## **Chapter 1.0: Warnings and Cautions**

Many tests and procedures outlined in this manual involve exposure to components that operate at potentially lethal voltage levels. To eliminate this hazard, service personnel must ensure that the incoming three-phase AC power has been disconnected, locked out, and tagged.

### **DISCLAIMER OF WARRANTY**

Magnetek, hereafter referred to as Company, assumes no responsibility for improper use of supplied product by untrained personnel. Product should only be installed or repaired by a trained technician who has read and understands the contents of this manual. Improper installation or service can lead to unexpected, undesirable, or unsafe operation or performance. This may result in damage to equipment or personal injury. Company shall not be liable for economic loss, property damage, or other consequential damages or physical injury sustained by the purchaser or by any third party as a result of such operation or service. Company neither assumes nor authorizes any other person to assume for Company any other liability in connection with the sales or use of this product.

### **PRODUCT WARRANTY INFORMATION**

For information on Magnetek's product warranties by product type please visit [www.magnetekmh.com](http://www.magnetekmh.com).

### **©2019 MAGNETEK**

All rights reserved. This notice applies to all copyrighted material included with this product, including, but not limited to, this manual and software embodied within the product. This manual is intended for the sole use of the persons to whom it was provided, and any unauthorized distribution of the manual or dispersal of its contents is strictly forbidden. This manual may not be reproduced in whole or in part by any means whatsoever without the expressed written permission of Magnetek.

## Chapter 2.0: Disconnecting Means/Overcurrent Protection

Note: Magnetek recommends using the following Disconnecting Means and Overcurrent Protection Guidelines as published in the 2005 National Electrical Code, copyright 2004.

### 2.1: Disconnecting Means

**2.1.(a): 610.31 Runway Conductor Disconnecting Means:** A disconnecting means, having a continuous ampere rating not less than that computed in Sections 610.41(e) and (f), shall be provided between the runway contact conductors and the power supply. Such disconnecting means shall consist of a motor circuit switch, circuit breaker, or molded case switch.

This disconnecting means shall:

**2.1.(a). (i):** Be readily accessible and operate from the ground or floor level.

**2.1.(a).(ii):** Be arranged to be locked in the open position.

**2.1.(a).(iii):** Open all ungrounded conductors simultaneously.

**2.1.(a).(iv):** Be placed within view of the crane or hoist, and the runway contact conductors.

2.2: **610.32 Disconnecting Means for Crane and Monorail Hoists:** A motor circuit switch or circuit breaker, arranged to be locked in the open position, shall be provided in the leads from the runway contact conductors or other power supply on all cranes and monorail hoists. Where disconnecting means is not readily accessible from the crane or monorail hoist operating station, means shall be provided at the operating station to open the power circuit to all motors of the crane or monorail hoists.

2.3: **610.33 Rating of Disconnecting Means:** The continuous ampere rating of the switch or circuit breaker, required by Section 610.32, shall not be less than 50 percent of the combined short-time ampere rating of the motors, or less than 75 percent of the sum of the short-time ampere rating of the motors required for any single motion.

### 2.4: Overcurrent Protection

The use of Overcurrent Protection shall be provided in accordance with NEC Standard 610.41 through 610.43. Excerpts from 2005 National Electrical Code, copyright 2004.

### 2.5: 610-41. Feeders, Runway Conductors:

**2.5.(a).(i): Single Feeder.** The runway supply conductors and main contact conductors of a crane or monorail shall be protected by an overcurrent device(s) that shall not be greater than the largest rating or setting of any branch circuit protective device, plus the sum of the nameplate ratings of all the other loads with application of the demand factors from Table 610-14(e).

**2.5.(a).(ii): More Than One Feeder Circuit.** Where more than one feeder circuit is installed to supply runway conductors, each feeder circuit shall be sized and protected in compliance with 610.41(A).

2.6: **610-42. Branch-Circuit, Short Circuit Ground Fault Protection.** Branch circuits shall be protected in accordance with 610.42(A). Branch-circuit taps, where made, shall comply with 610-42(B).

**2.6.(a).(i): Fuse or Circuit Breaker Rating.** Crane, hoist, and monorail hoist motor branch circuits shall be protected by fuses or inverse-time circuit breakers having a rating in accordance

with Table 430.52. Where two or more motors operate a single motion, the sum of their nameplate current ratings shall be considered as that of a single motor.

**2.6.(a).(ii): Taps.**

**(1) Multiple Motors.** Where two or more motors are connected to the same branch circuit, each tap conductor to an individual motor shall have an ampacity not less than one-third that of the branch circuit. Each motor shall be protected from overload according to 610.43.

**(2) Control Circuits.** Where taps to control circuits originate on the load side of a branch-circuit protective device, each tap and piece of equipment shall be protected in accordance with 430.72.

**(3) Brake Coils.** Taps without separate overcurrent protection shall be permitted to brake coils.

2.7: **610.43 Motor and Branch-Circuit Overload Protection:** Each motor, motor controller, and branch-circuit conductor shall be protected from overload by one of the following means:

**2.7.(a).(i):** A single motor shall be considered as protected where the branch-circuit overcurrent device meets the rating requirement of Section 610.42.

**2.7.(a).(ii):** Overload relay elements in each ungrounded circuit conductor, with all relay elements protected from short circuit by the branch-circuit protection.

**2.7.(a).(iii):** Thermal sensing devices, sensitive to motor temperature or to temperature and current, that is thermally in contact with the motor winding(s). A hoist or trolley shall be considered to be protected if the sensing device is connected in the hoist's upper limit switch circuit so as to prevent further hoisting during an overload condition of either motor.

**Note:** Please reference the National Electrical Code (NEC) for exemptions or additional information on Disconnecting Means and Overcurrent Protection.

Figure 1

### Standard System Layout Without Expansion

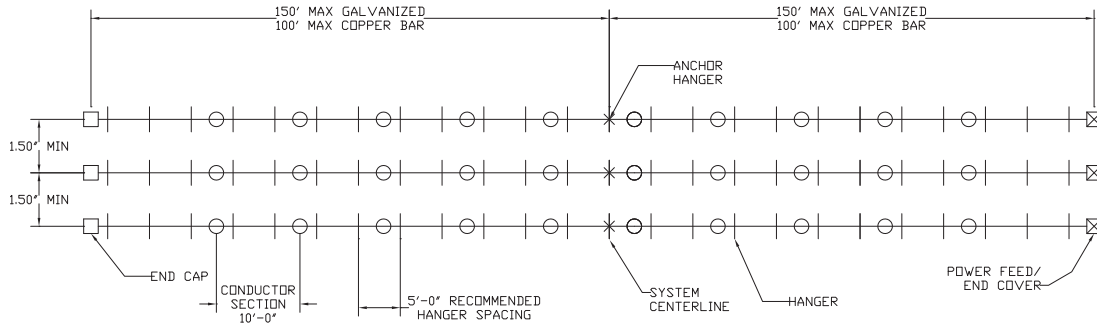

### Standard System Layout With Single Expansion

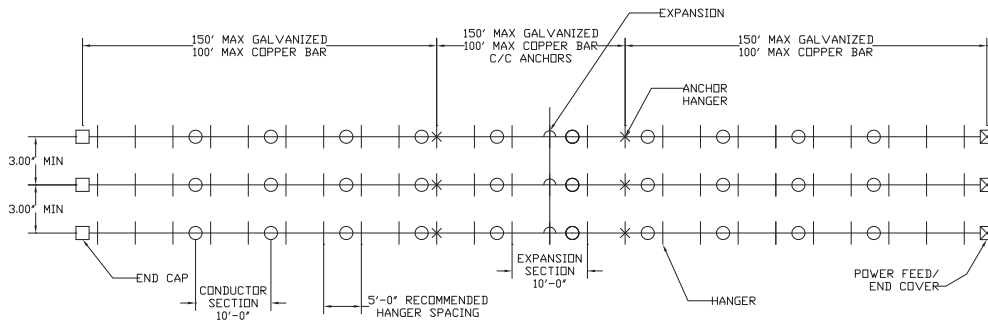

### Standard System Layout With Multiple Expansion

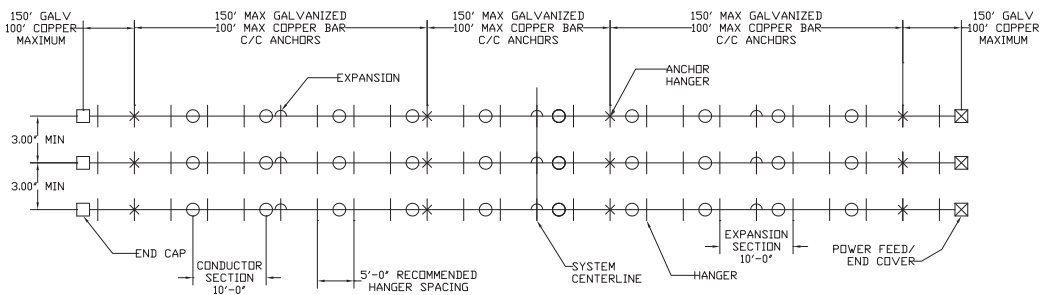



## Chapter 3.0: Assembly Guidelines

### 3.1: System *without* Expansions

*The following are general system installation guidelines; see the following sections for specific component installation instructions.*

**3.1.(a):** Check alignment of mounting brackets prior to assembling hangers and bar. Correct any brackets that are misaligned. Mounting brackets should not exceed  $\frac{1}{4}$ " in horizontal and vertical misalignment over 5'0" mounting centers.

**3.1.(b):** To expedite assembly, it is recommended that the hanger brackets be loosely assembled to the mounting brackets prior to hanging the mounting brackets.

**3.1.(c):** Anchor hangers are located on one of the first mounting brackets on either side of the centerline/joint.

**3.1.(d):** Locate the end of a bar (joint) approximately 2½ feet from a hanger – this will prevent joint/hanger interference as the system is assembled.

**3.1.(e):** From the center of the run – snap anchor hanger brackets on the conductor bar, snap the end of the bar away from centerline into the hangers.

**3.1.(f):** Locate bar in appropriate position on the mounting brackets and tighten hangers to the mounting brackets.

**3.1.(g):** Add the additional number of conductors to fill the snap-in hangers. Remember to space the hangers equally before tightening to mounting bracket/bar.

**3.1.(h):** Continue to mount bar in one direction from center applying conductors to the end of those previously assembled.

**3.1.(i):** Between each individual bar (and a joint keeper if applicable) a joint cover must be mounted. When assembling a joint, the following items should be checked:

**3.1.(i).(i):** The ends of the conductor bars are located tightly close to each other (never to exceed  $\frac{1}{8}$ " gap).

**3.1.(i).(ii):** The joint cover is centered over each joint.

**3.1.(j):** Power feeds are designed to be mounted at system joint locations. Ensure that the hardware is tightened appropriately and the power feed cover is properly located on the bar. Be sure feed cables do not apply any additional stress on the conductor bars.

**3.1.(k):** At the end of each conductor run, end caps are needed to properly insulate the system.

**3.1.(l):** Return to the center of the system and continue to assemble in the other direction.

**3.1.(m):** Collectors: Check that mounting post is an equal distance vertically from each conductor bar. This will provide equal tension per collector. Each collector is to be centered on the conductor on which it is to travel.

### 3.2: System *with* Expansions

*The following are general system installation guidelines; see the following sections for specific component installation instructions.*

**3.2.(a):** Check alignment of mounting brackets prior to assembling hangers and bar. Correct any brackets that are misaligned. Mounting brackets should not exceed ¼" in horizontal and vertical misalignment over 5'0" mounting centers.

**3.2.(b):** To expedite assembly, it is recommended that the hanger brackets be loosely assembled to the mounting brackets prior to hanging the mounting brackets.

**3.2.(c):** Anchor hangers will be located on mounting brackets: 75 ft. from the centerline of the expansion assembly on 90 Amp and 110 Amp systems; 50 ft. from the centerline of the expansion assembly on 250 Amp and 350 Amp systems.

**3.2.(d):** Begin system assembly by installing the expansion assemblies or the first set of expansion assemblies. Locate the end of the expansion (joint) approximately 2½ ft. from a hanger – this will prevent joint/hanger interference as the system is assembled.

**3.2.(e):** Once the first set of expansion assemblies are assembled to the mounting brackets, begin to assemble additional conductors to the system in one direction from the expansion.

**3.2.(f):** The expansion gap will need to be set as per the chart located on page 19. Note: Set gap to the appropriate dimension. This will need to be verified prior to clamping the anchor hangers.

**3.2.(g):** Continue to assemble the system in one direction through the anchor hangers (do not assemble at this time) to the end or to the next expansion assembly.

**3.2.(h):** Between each individual bar (and a joint keeper if applicable), a joint cover must be mounted. When assembling a joint, the following items should be checked:

**3.2.(i).(i):** The ends of the conductor bars are located tightly close to each other (never to exceed 1/8" gap).

**3.2.(i).(ii):** The joint assembly is centered over each joint.

**3.2.(j):** Power feeds are designed to be mounted at system joint locations. Ensure that the hardware is tightened appropriately and the power feed cover is properly located on the bar. Be sure feed cables do not apply any additional stress on the conductor bars.

**3.2.(k):** From the other end of the initial expansion assemblies installed, continue to install the system in the other direction.

**3.2.(l):** At the end of each conductor run, end caps are needed to properly insulate the system.

**3.2.(m):** With the system installed, except for assembling of anchors to the bar, return to the first set of anchors located from the end of the conductor run and assemble the anchor assembly.

**3.2.(n):** Go to the first set of expansion assemblies located next to the previously tightened anchor hangers and confirm the expansion gap setting. Adjust if necessary.

**3.2.(o):** Go to the next anchor hanger on the other side of the expansion and assemble the anchor assembly to the bar, if there is more than one expansion area on the system, continue down the conductor run and repeat the above procedure.

**3.2.(p):** Confirm gap settings at each expansion location.

**3.2.(q):** Collectors: Check that mounting post is an equal distance vertically from each conductor bar. This will provide equal tension per collector. Each collector is to be centered on the conductor on which it is to travel.

## Expansion Drawings

Figure 2

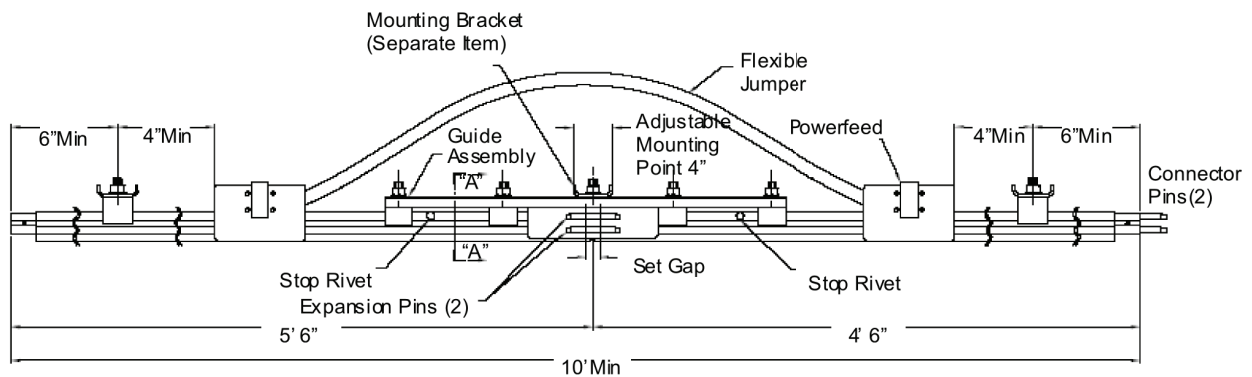

**Chapter 4.0: Conductor Application and Support Spacing**

4.1: Determine if the system is to be horizontal mount (bottom entry) or vertical mount (side entry). The following table shows the appropriate support spacing.

<b>System</b>	<b>Mounting</b>	<b>8-Bar Support Conductor Every:</b>
90 Amp Galvanized Steel Conductor	Horizontal Mount	5 Feet
	Vertical Mount	4 Feet
110 Amp Galvanized Steel Conductor	Horizontal Mount	5 Feet
	Vertical Mount	4 Feet
250 Amp* Copper Conductor	Horizontal Mount	5 Feet
	Vertical Mount	4 Feet
350 Amp* Copper Conductor	Horizontal Mount	5 Feet
	Vertical Mount	4 Feet

\*Joint keeper clips required on all 8-Bar copper conductor systems.

4.2: Determine the maximum ambient temperature at the conductor system elevation:

**4.2.(a):** Under 77° F: use standard PVC insulating covered system.

**4.2.(b):** 160° F - 280° F: use high heat insulating covered system.

**4.2.(c):** Over 280° F: consult the factory.

4.3: Determine the conductor system required, using a 70% duty cycle with a two-minute cycle time operation (84 seconds on and 36 seconds off).

**4.3.(a):** Conductor ampacity considerations.

**4.3.(b):** Voltage drop considerations.

**4.3.(c):** Expansion considerations (standard rail and building expansion) (Refer to Expansion Sections on page 18).

**Chapter 5.0: Mounting Brackets**

- 5.1: Install mounting brackets (channels, angles, tees, etc.) at the required spacing (see Conductor Application and Support Spacing on page 12).
- 5.2: The brackets should be pre-punched or drilled to accept 3/8" hanger mounting bolts. The minimum distance from the web to the first hanger clamp is 3".

**Figure 3**

**Web Mounting Brackets**

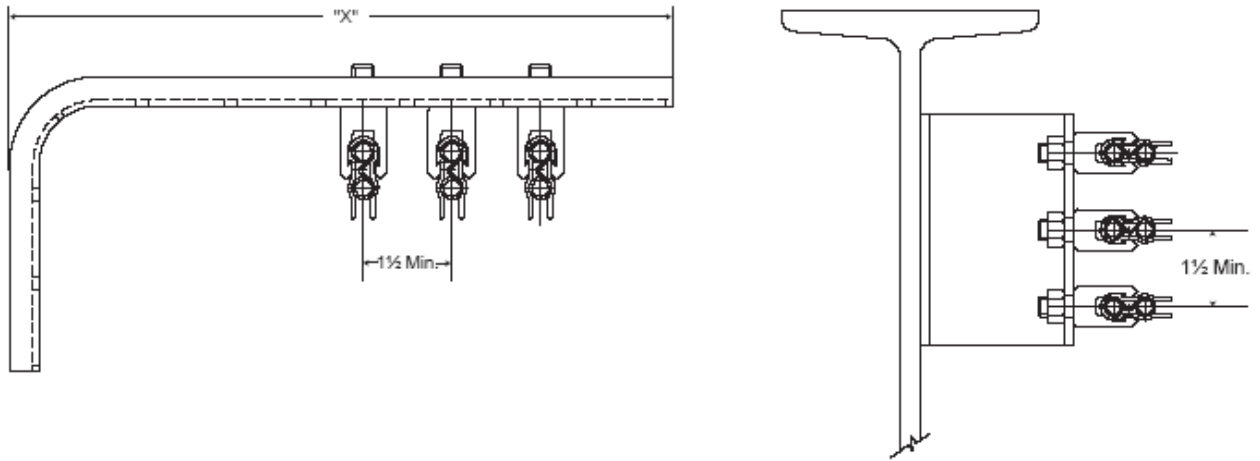

Web Mount Bracket X-Dimension	
Bracket	X Dimension
BKS-W15	11"
BKS-W18	14"
BKS-W24	20"

Figure 4

Flange Mounting Brackets

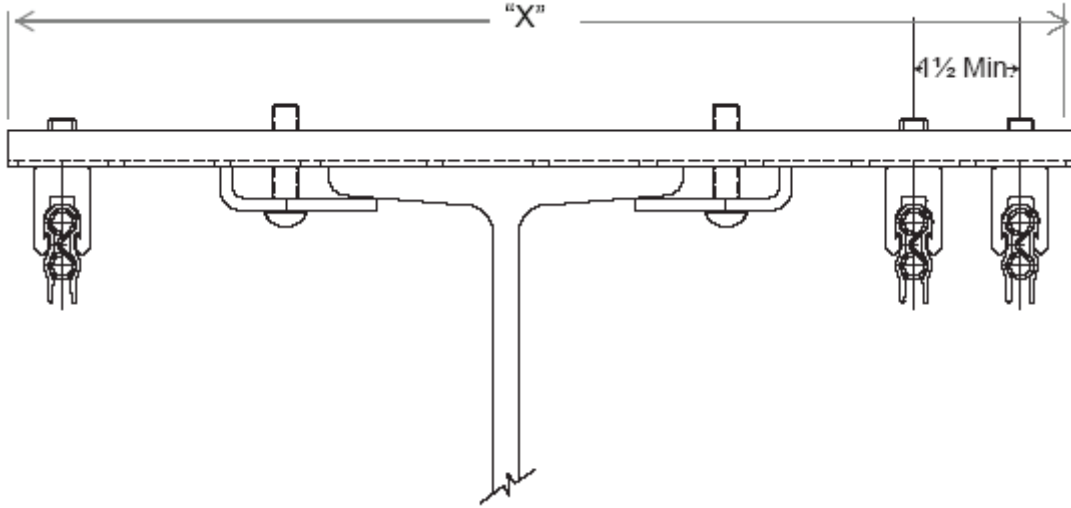

Flange Mount Bracket X-Dimension	
Bracket	X Dimension
BKS-F15	15"
BKS-F18	18"
BKS-F24	24"

## Chapter 6.0: Hanger Assembly

6.1: Install hanger clamps securely to mounting brackets leaving clamping bolts loose.

**6.1.(a):** Make sure conductor bar openings are straight along runway path.

Note: Snap-in type hangers do not have clamping bolts. **Maximum hex nut torque for nylon hanger is 65 inch pounds.** Use steel bolt hanger on all high temperature cover applications.

6.2: Anchor Hangers

Note: Anchor hangers should be used at the midpoint between expansion gaps (see page 11) and at the midpoint on all other systems. Anchor hangers should also be used where conductor movement must be restricted. Install anchor hangers according to the following directions.

Figure 5

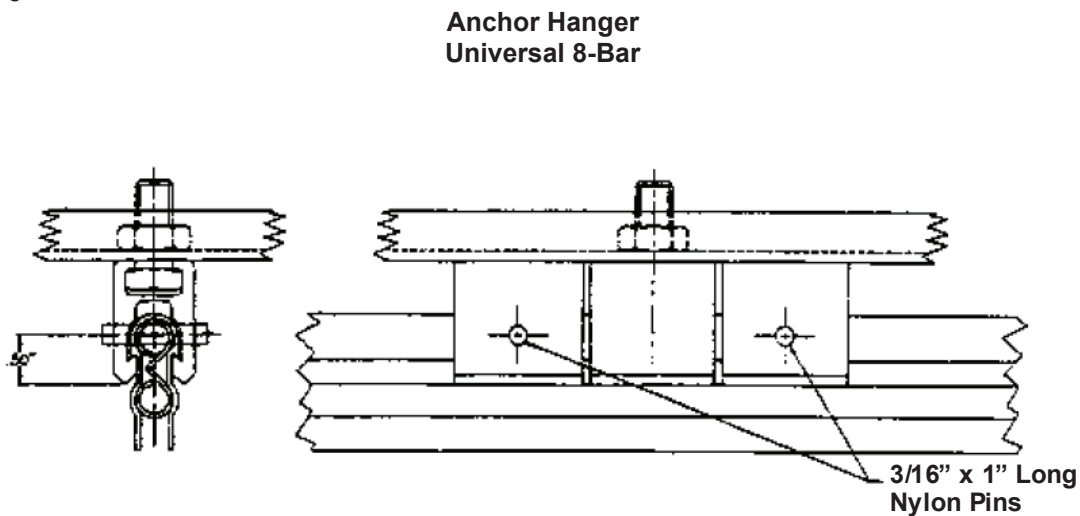

6.3: 8-HA for Universal 8-Bar Systems (see figure 5, page 15)

**6.3.(a):** Insert conductor section into the clamp assembly. Install an Anchor Hanger on both sides of a hanger clamp assembly.

**6.3.(b):** Drill 3/16" hole through the hanger and conductor section, using the pre-drilled hole in the anchor hanger as a guide.

**6.3.(c):** Drive the nylon pin into the hanger and through the conductor bar section. The pin should penetrate out the other side of the hanger.

Note: Begin with the conductor run that is the closest to the runway beam or support structure, then work to the outside run.

**Chapter 7.0: Joint Keeper Installation – For Copper Conductors Only**

Note: Joint Keepers must be used on all 8-Bar Copper Systems.

**Figure 6**

**Joint Keeper**

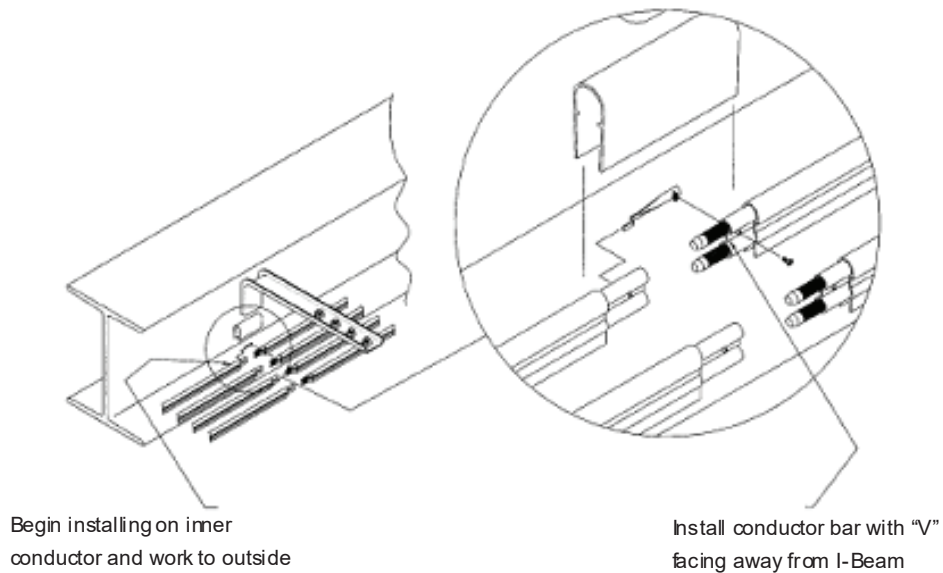

**Figure 7**

**Joint Keeper**

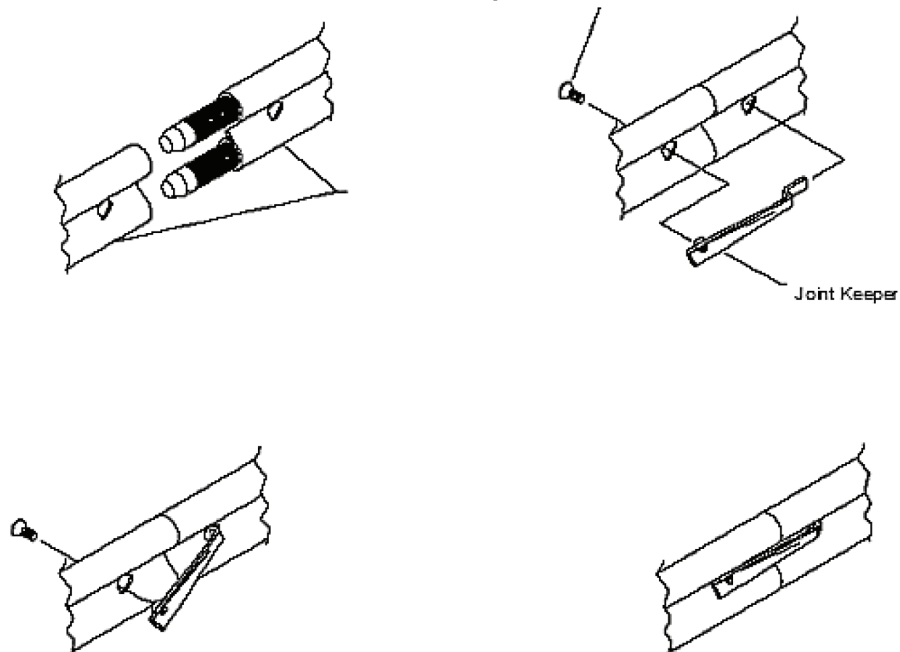



## Chapter 8.0: Joint Covers

8.1: Center joint cover over joint assembly.

**8.1.(a):** Install insulating joint cover over each connected joint by snapping joint cover over conductor bar splice joint.

Note: Splice joints should be no less than 6" from mounting bracket.

8.2: Power Feeds

**8.2.(a):** Install center power feed at joint.

**8.2.(b):** The power feed clamps over the top diameter of the conductor bar at the joint.

**8.2.(c):** Tighten the power feed half firmly over conductor bar.

**8.2.(d):** Install feed cable into power feed cable connector (connector will vary on type of rating on power feed).

8.3: Power Feed Wire/Connection

Power Feed cables must be sized to meet the ampere demands of the conductor bar and be connected to the power feed assembly using a properly sized connector. See below for Minimum Feed Cable Size for each conductor amperage rating. Reference NEC Table 610.14 for minimum cable sizing.

Conductor Bar	Min. Feed Cable Size
90 Amp	4 AWG
110 Amp	2 AWG
250 Amp	3 / 0 AWG
350 Amp	250 MCM

Note: Check local electrical codes for any additional specifications and/or restrictions.

Note: Power feed cables must be supported from the top to prevent vertical loading on the conductor bar.

**8.3.(a):** Install power feed cover halves over power feed assembly with hardware provided.

8.4: End Covers

**8.4.(a):** Remove connector pins (if any) from conductor bar end.

**Chapter 9.0: Expansion Sections**

9.1: Install expansion sections (if required – see table below) before installing conductor sections.

**9.1.(a):** Galvanized steel conductors – every 150 feet. (e.g. 1 in center of 300’ run)

**9.1.(b):** Copper systems – every 100 feet. (e.g. 1 in center of 200’ run)

**9.1.(c):** All systems – at building expansion areas.

<b>ELECTRIFICATION 8-BAR</b>					
90 Amp & 110 Amp Galvanized Steel Conductors			250 Amp & 350 Amp Copper Conductors		
Conductor Length	Anchors Required	Expansions Required	Conductor Length	Anchors Required	Expansions Required
Up to 299’	1	0	Up to 199’	1	0
300’ to 449’	2	1	200’ to 299’	2	1
450’ to 599’	3	2	300’ to 399’	3	2
600’ to 749’	4	3	400’ to 499’	4	3
750’ to 999’	5	4			

Note: For outdoor applications, additional expansions may be required. Please consult the factory.

**9.1.(d):** Snap or slide the conductors into the hangers. When clamp-type hangers are used, tighten the clamping bolt only after the conductor sections are joined.

**9.1.(e):** To join conductor sections, clean any dirt or oil on connector pins and join conductor sections using the connector tool. File any rough joints. Joints should be completely closed.

**9.1.(f):** Install joint keeper clips on ALL 8-Bar copper conductor systems for the inverted V side of conductor (see page 15).

9.2: Expansion Gap Installation

**9.2.(a):** Expansion gap assemblies must be supported at the gap location.

**9.2.(b):** A 10-foot expansion gap assembly is installed in the same manner as other 10-foot sections of conductor bar.

**9.2.(c):** For shipping purposes, the gap has been completely closed and must be adjusted according to the ambient temperature. Maximum hex nut torque is 65 lb-in.

Note: Two sets of anchor hangers are supplied with each expansion assembly. The hangers must be installed to control expansions.

9.3: Expansion Gap Settings

The actual gap setting for each ELECTRIFICATION expansion section is determined by the expected temperature variance and the ambient temperature at the time of installation. Set the gaps according to the following chart.

Operating Minimum	Temperatures Maximum	Ambient Temperature	Gap Width Setting
0°F	100°F	25°F	1.5"
		50°F	1.0"
		75°F	0.5"
25°F	125°F	50°F	1.5"
		75°F	1.0"
		100°F	0.5"
50°F	150°F	75°F	1.5"
		100°F	1.0"
		125°F	0.5"

9.4: Anchoring Requirements

All ELECTRIFICATION Conductor Bar Systems must be anchored to permit controlled expansion and contraction of the conductor bar. Anchor all systems according to the following chart. Two anchor hangers are provided with each ELECTRIFICATION 10ft. expansion section. Purchase anchor hangers separately for systems without expansion sections.

<b>Type of System</b>	<b>Anchor Point Locations</b>
All Conductor Bar Systems WITHOUT Expansion Sections	Place anchors at MIDPOINT of EACH conductor run
All Conductor Bar Systems with ONE set of Expansion Sections	Place anchors at MIDPOINT between the Expansion Sections and EACH end of the runway
All Conductor Bar Systems with MULTIPLE (2 or more) Expansion Sections on each Conductor Run	Place anchors the same as with one Expansion Section and ALSO at MIDPOINT between EACH Expansion Section

## Chapter 10.0: Transfer Caps

10.1: Install conductor support brackets with anchor clamps as shown (see separate instructions for anchor clamps).

**10.1.(a):** Drill ends of conductor bars with  $19/64$ " drill to accommodate transfer cap pins.

**10.1.(b):** Tap in transfer cap with rubber mallet.

**10.1.(c):** File or de-burr any rough edges along collector tracking surfaces.

**10.1.(d):** Align opposing conductor runs and anchor, to prevent movement during vibration or collector transfer.

Figure 8

### 8-Bar Transfer Cap

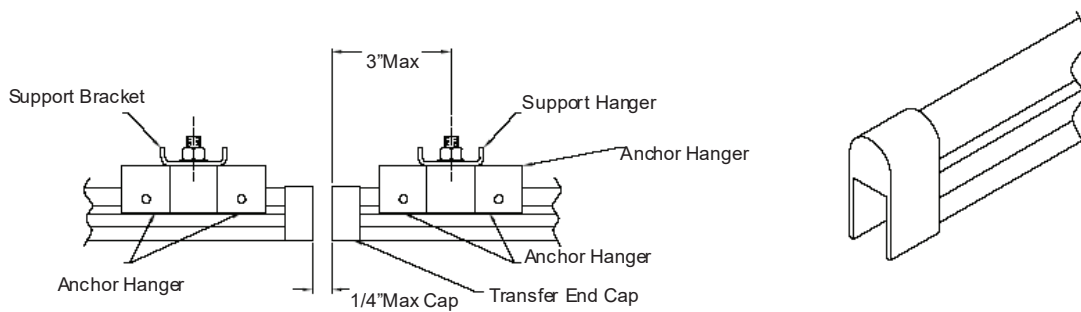

## Chapter 11.0: Collectors

11.1: Mount the collector mounting post so the horizontal centerline of the post is 3.5" to 4.5" from the running surface of the conductor bar.

**11.1.(a):** Slide each of the collectors onto the mounting post until they are directly under the conductor bar it is going to run in.

Note: When mounting tandem collectors, be sure each collector shoe is positioned in the appropriate conductor bar.

**11.1.(b):** Tighten each bolt (upper and lower) until the collector is firmly in place (10 lb-ft).

**11.1.(c):** Termination of collector leads should be in accordance with NEC and local electrical standards.

Figure 9

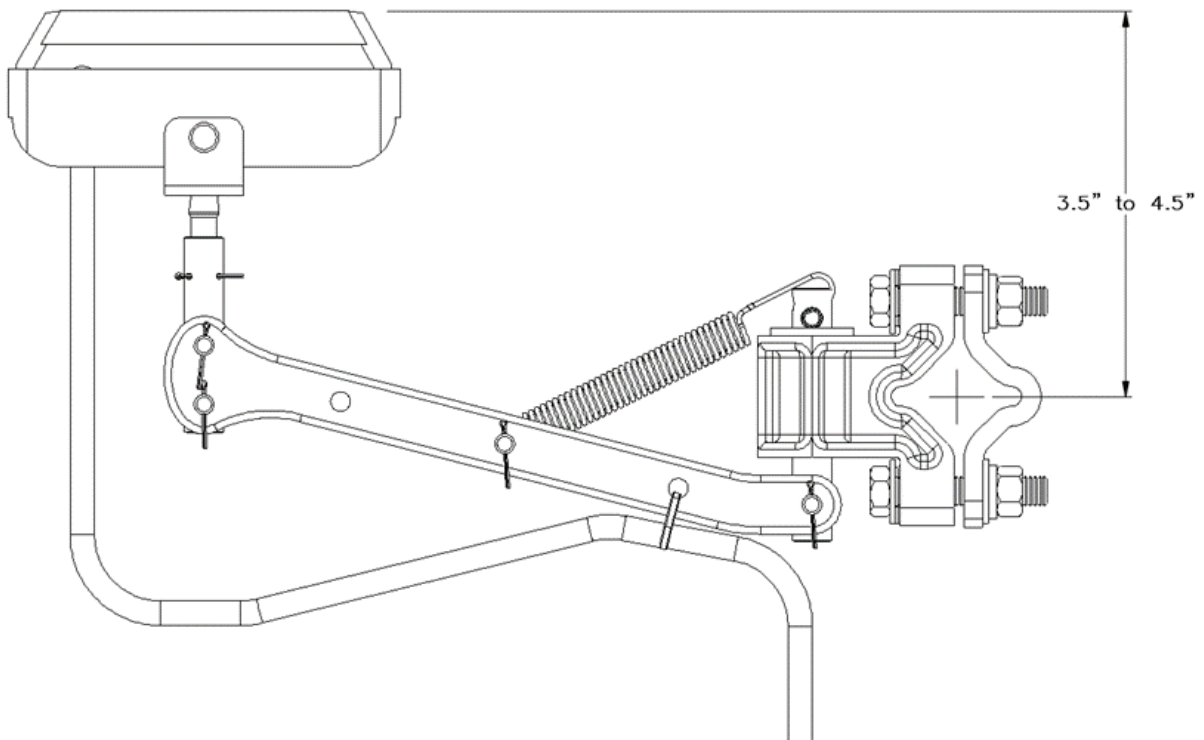

**Note:** Before performing any maintenance on the system, be sure that the power to the system has been disconnected following lockout tagout procedures.

Figure 10

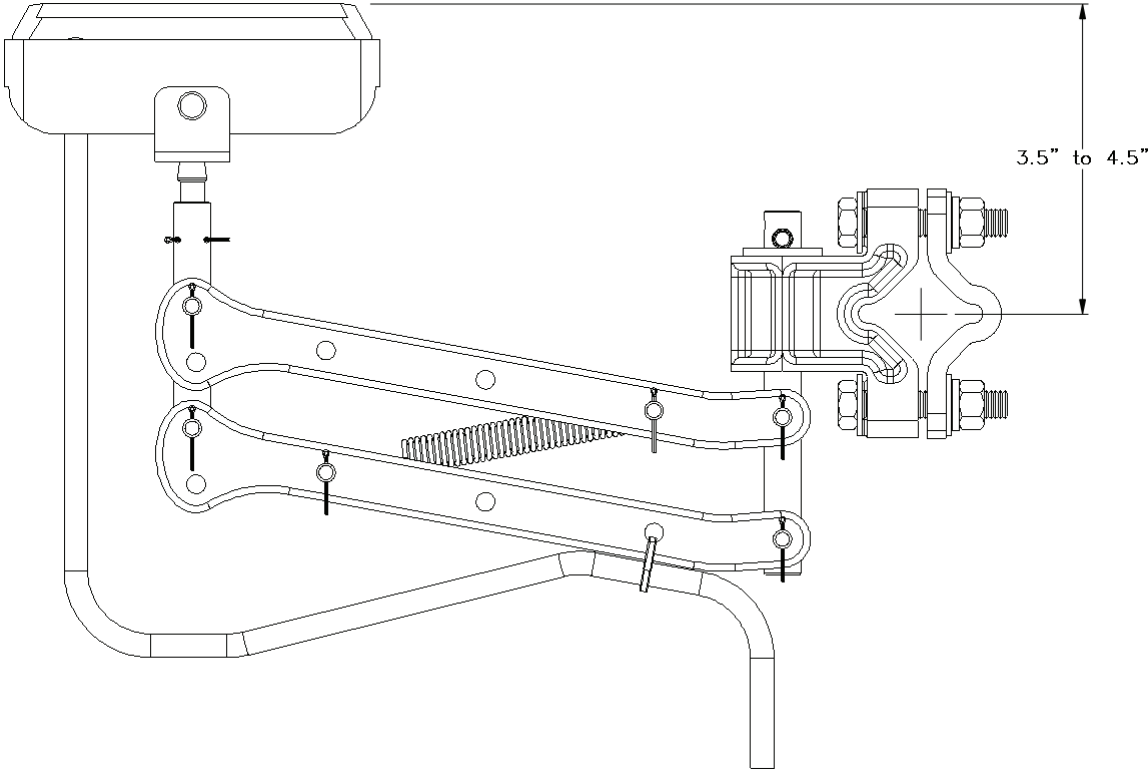

Figure 11

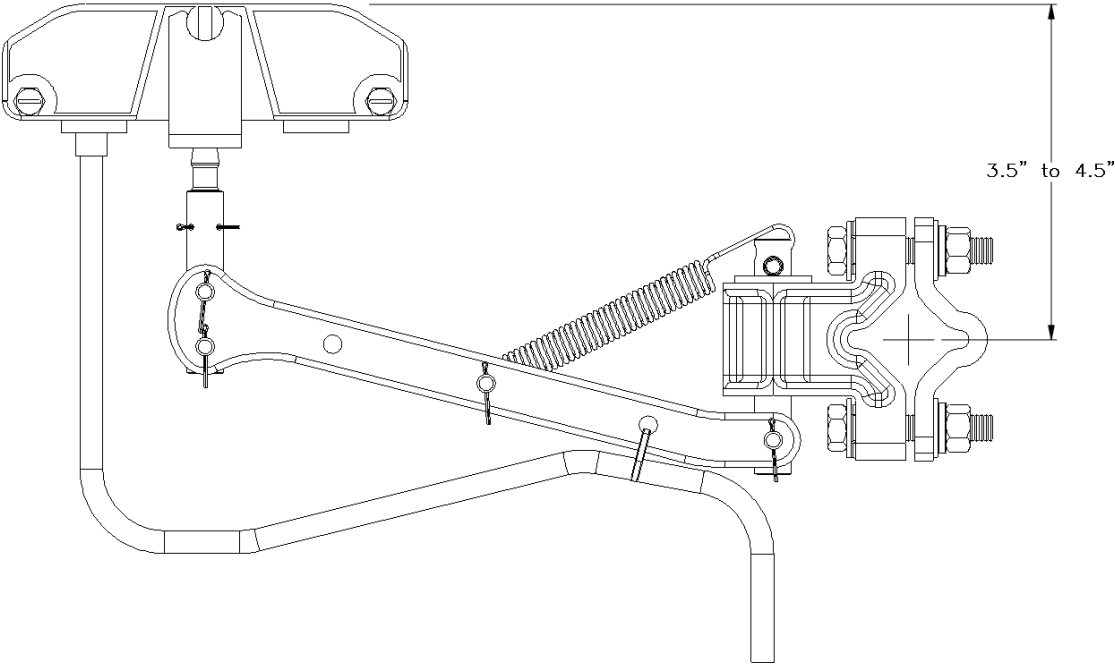
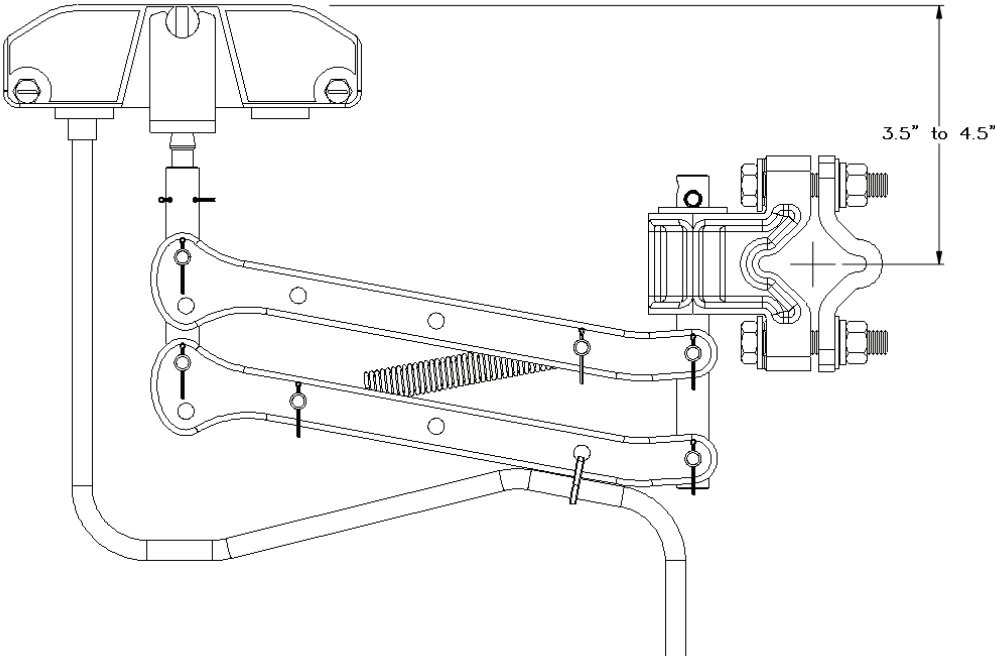

Figure 12





## 11.2: Collector Shoe Replacement

**11.2.(a):** Remove the cotter pin from the head pivot tube. Discard old cotter pin and replace with a new one.

**11.2.(b):** Remove the collector head assembly from the pivot tube. If replacing the entire collector move on to step **11.2.(c)** and stop after step **11.2.(d)**. If replacing just the collector shoe move onto step **11.2.(e)**.

**11.2.(c):** Disconnect power wire from source. Reassemble the new collector head assembly into the collector pivot tube and insert the new cotter pin.

**11.2.(d):** Termination of the collector leads should be in accordance with NEC and local electrical standards.

**Figure 13**

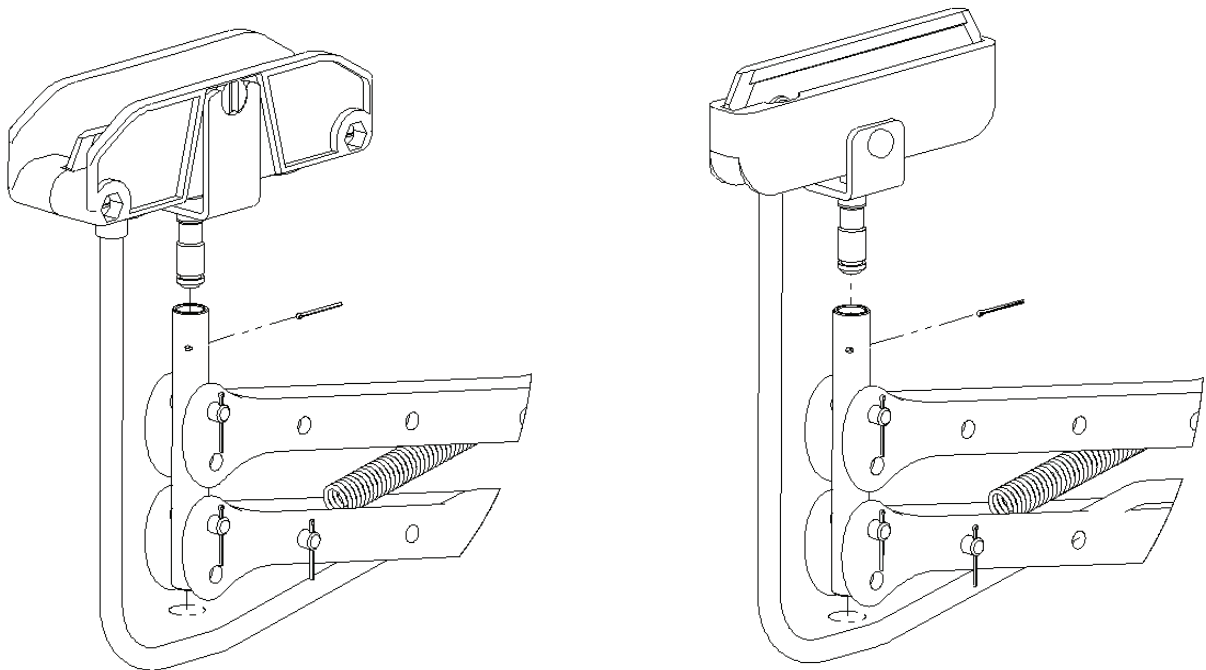

**11.2.(e):** Remove the collector shoe from the collector head assembly. For the standard shoe holder, use a flat-headed screwdriver to loosen the two halves in order to remove the collector shoe.

**11.2.(f):** Remove connector hardware from the collector shoe and discard worn collector shoe.

**11.2.(g):** Visually inspect feed cable for any cuts or wear; replace if necessary. Reassemble feed cable to the collector shoe using connector hardware. Push the collector shoe straight into the shoe holder. For standard shoe holder use a flat-headed screwdriver to retighten screws in order to keep collector shoe in place.

**11.2.(h):** Reassemble the new collector head assembly into the collector pivot tube and insert the new cotter pin.

**Figure 14**

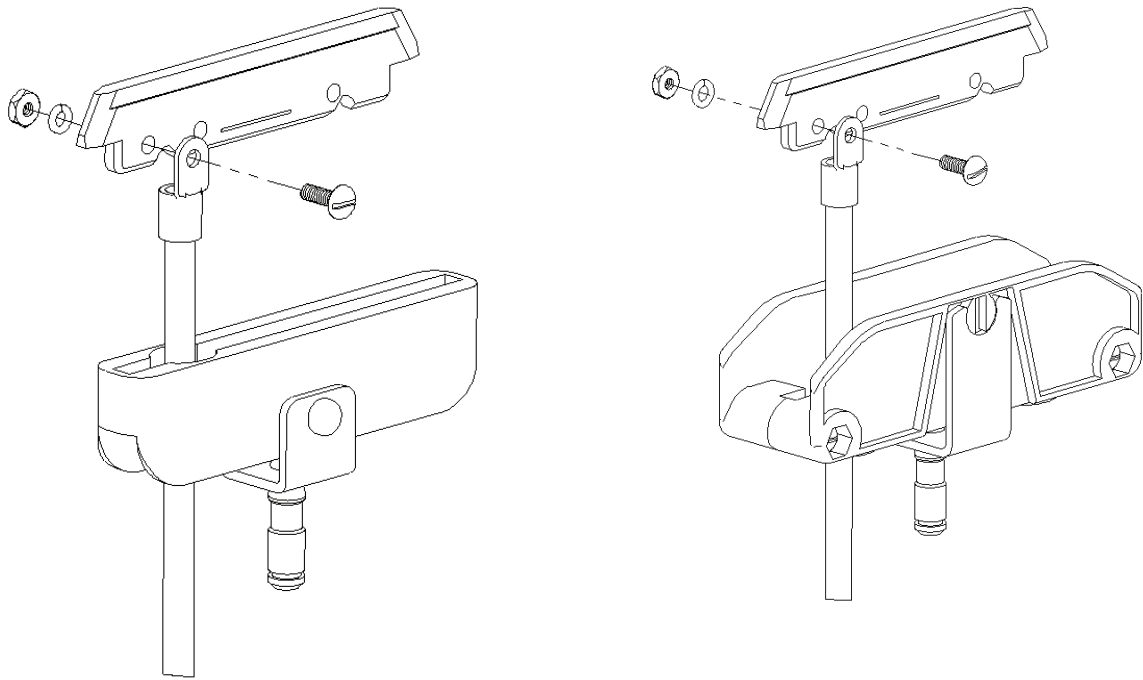

## **Chapter 12.0: Final Inspection**

12.1: Final inspection of all components should be made, including the following important items:

**12.1.(a):** Make sure the conductor bar runs are straight. Adjust any hanger clamps, which are not straight, and replace any conductor bar which may have been bent or damaged.

**12.1.(b):** No HOT (electrically energized) bare metal parts should be exposed. Make sure insulating covers, joint covers, power feed covers, and end covers are securely in place to prevent any accidental contact by personnel.

**12.1.(c):** Run the equipment back and forth several times along the entire system length to make sure the system functions properly.

**12.1.(d):** File any conductor joints that are uneven or not smooth.

**12.1.(e):** Make sure the conductors are able to float, except at anchor points, to allow for expansion and contraction due to temperature variations.

**12.1.(f):** Make sure there is no excessive ambient heat. Heat shields may need to be installed near furnaces, etc.

**12.1.(g):** Make sure that the system is protected from falling objects and water.

## **Chapter 13.0: Special Applications and Field Instructions**

### 13.1: Field Cutting of Conductor Bar Sections

**13.1.(a):** Cut ends squarely with metal cutting band saw or hack saw.

**13.1.(b):** If cut conductor section is to be joined with another conductor section, cut insulating cover back 1" from end of conductor. Leave insulating cover flush with end of conductor if transfer cap is to be installed.

**13.1.(c):** Drill ends of cut conductors as follows:

- For 90 Amp conductors, use 19/64" drill.
- For 110, 250 and 350 Amp conductors, use 1/4" drill.
- For transfer caps, use 19/64" drill.

**13.1.(d):** De-burr ends of conductors.





**MAGNETEK**  
MATERIAL HANDLING

Electrification 8-Bar  
Conductor Bar System Instruction Manual  
October 2019