



SEQ Electric Chain Hoists Hook or Suspension Bar Mount



SEQ010SD

Harrington's revolutionary SEQ Series single-phase dual speed (VFD Control) electric chain hoists are designed for easy installation and operation in medium- and heavy-duty industrial applications. These hoists have an extremely compact and lightweight body and are perfect for any work station application. The SEQ hoist includes a no-load high-speed function that automatically increases hoist speed up to 130 percent when the load is less than 30 percent of working load limit.

Features and Benefits

Pull-Rotor Motor Brake

Extremely durable and reliable, this advanced design contains no brake coil to fail like conventional disc brakes.

External Motor Fan

Functions to quickly eliminate resistor, motor and brake heat. This results in improved hoist duty rating and greatly lengthens brake life. Motor is totally enclosed, fan cooled (TEFC).

Precision Machined Helical Gears

Immersed in oil bath lubrication results in quiet, smooth and cool operation.

Chain Container

Durable plastic containers are standard.

Corrosion Resistant Load Chain

Nickel-plated, Grade 80, DIN chain for superb durability and strength.

Forged Carbon Steel Hooks

Under excessive loads will open gradually and not fracture. Ball bearings produce smooth rotation. Bottom hook will swivel 360°. Heavy-duty hook latches are standard.

Optional Suspension Bar

For low headroom or enclosed track trolley applications. Easily changed from top hook to suspension bar.

Compact Aluminum Body

Die-cast body is lightweight and offers low headroom – one of the best in the industry. Paint is electrostatically applied.

Completely Sealed Body

Suitable for both indoor and outdoor applications, including harsh environments. (Consult Owner's Manual for details.) Gaskets throughout the hoist provide for an IP55 rating.

Variable Frequency Drive (VFD)

Dual speed controls via "under-the-cover" variable frequency drive for both single-phase and three-phase hoists. VFD includes count hour meter, load limiter and no-load high-speed function.

Long Life Friction Clutch

Protects hoist from damage and prevents overwinding.

Upper/Lower Limit Switch

Low profile upper and lower limit switches provide excellent headroom.

Unique Chain Guide

Provides quiet and smooth guiding of chain. Heavy cast iron construction for improved wear versus stamped steel design offered by many manufacturers.

Durable Push Button Pendant

Easy to use, one-handed operation. Rated IP65. Standard control voltage is 24V. Strain relief wire is molded to pendant cord for added support and dependability. E-Stop is standard on all pendants.

Extreme Duty Motor

Increased performance through 30/10-minute duty rating, H4 classification, Class B insulation, cooling fins and external thermal motor protection.

Load Sheave

Five deep-groove pockets fully support the load chain during operation. Reduces vibration and chain wear. Provides true vertical lift.

Operating Conditions

Recommended for -4° to +104°F and humidity of 85% or less.

Standard Hoist Specifications

Capacity Range

1/8 Ton – 1 Ton

Standard Voltage

(Re-connectable)
115-1-60
(220-230)-1-50/60

Control Voltage

24VDC

Duty Cycle*

30/10 Min.

Classification*

ASME H4
ISO 1/8-1/2T M6; 1T M5
FEM 1/8-1/2T 3m; 1T 2m

Conformance

UL 508, 508A 1004
CSA C22.2 NO. 33, 14-13, 66

Ratings

Hoist – IP55
Pendant – IP65

Chain Falls

Single chain fall all capacities

Standard Lift

10' (longer lifts available)

Standard Pendant Drop

Standard pendant hangs approximately 4' above the hoist's fully extended bottom hook (longer drops available)

Standard Power Supply Length

15' (longer lengths available)

Mounting

Hook, suspension bar or trolley

Standard Pendants

2-button (momentary contacts) with emergency On/Off (maintained contacts)

Chain Containers

Standard plastic

*See page 79-81 for additional information.

HARRINGTON ELECTRIC CHAIN HOISTS



SEQ010SD
(shown with optional
Suspension Bar)

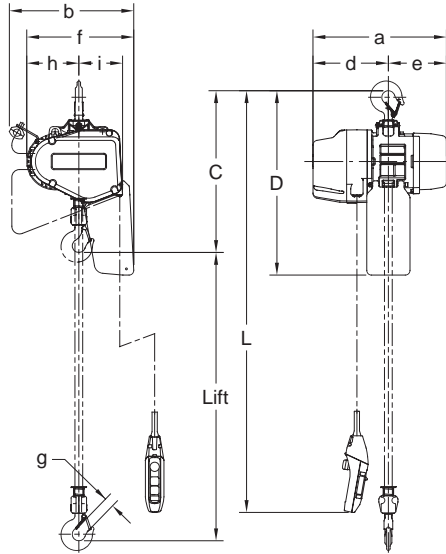

SEQ010SD Hook Mount

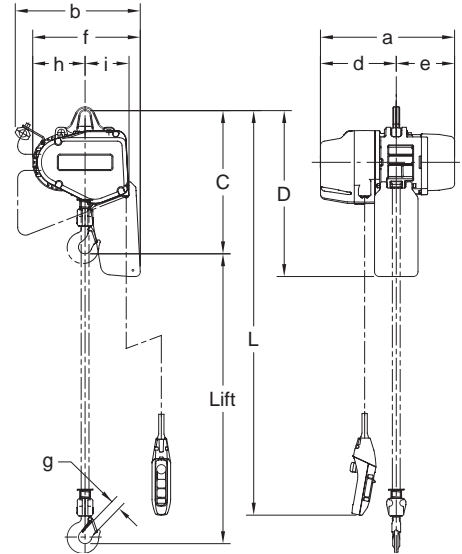

SEQ010SD Suspension Bar Mount

SEQ 1-PHASE DUAL SPEED VFD HOIST - SPECIFICATIONS

Cap. (Tons)	Product Code	Standard Lift (ft)	Push Button Cord L (ft)	Lifting Speed ² (ft/min)			Hoist Data ¹ Single-Phase		Load Chain Diameter (mm) x Chain Fall Lines	Net Weight (lbs)	Weight for Additional One Foot of Lift (lbs)	
							Output (Hp)	Rated Current (amps)				
				High	Low	No Load High Speed		@115V- 60Hz				@220-230V- 50/60Hz
1/8	SEQ001SD	10	8.2	56	9.2	72	0.67	11.0	7.1	5.6 x 1	71	0.48
1/4	SEQ003SD			33	5.5	43		12.7	7.2			
1/2	SEQ005SD			25	4.2	32	1.0	14.9	9.0	7.1 x 1	75	
1	SEQ010SD			17	3.9	30	1.3	19.5	12.0		97	

1) Hoists are voltage re-connectable between 115/220-230V
2) Speeds are adjustable between low and high speed

SEQ 1-PHASE DUAL SPEED VFD HOIST — DIMENSIONS

Capacity (Tons)	Product Code	Headroom C (in)		D (in)		a (in)	b (in)	d (in)	e (in)	f (in)	g (in)	h (in)	i (in)
		Top Hook	Susp. Bar	Top Hook	Susp. Bar								
1/8	SEQ001SD	17.3	15.6	21.0	19.1	16.4	14.4	9.1	7.4	11.7	1.1	5.4	5.0
1/4	SEQ003SD												
1/2	SEQ005SD	18.0	16.1	23.5	21.1	17.0	15.9	9.6	7.4	13.1	1.2	6.1	5.6
1	SEQ010SD	20.7	18.3										

SEQM Electric Chain Hoists with Motorized Trolleys



SEQM010SD-SD

Harrington's SMRQ Series dual speed (VFD Control) motorized trolley adds powered mobility to our SEQ Series single-phase dual speed (VFD Control) electric chain hoists for applications where long travel distance is needed.

Features and Benefits

Pull-Rotor Motor Brake

Extremely durable and reliable, this advanced design contains no brake coil to fail like conventional disc brakes.

External Motor Fan

Functions to quickly eliminate resistor, motor and brake heat. This results in improved hoist duty rating and greatly lengthens brake life. Motor is totally enclosed, fan cooled (TEFC).

Precision Machined Helical Gears

Immersed in oil bath lubrication results in quiet, smooth and cool operation.

Chain Container

Durable plastic containers are standard.

Corrosion Resistant Load Chain

Nickel-plated, Grade 80, DIN chain for superb durability and strength.

Forged Carbon Steel Hooks

Under excessive loads will open gradually and not fracture. Ball bearings produce smooth rotation. Bottom hook will swivel 360°. Heavy-duty hook latches are standard.

Compact Aluminum Body

Die-cast body is lightweight and offers low headroom – one of the best in the industry. Paint is electrostatically applied.

Completely Sealed Body

Suitable for both indoor and outdoor applications, including harsh environments. (Consult Owner's Manual for details.) Gaskets throughout the hoist provide for an IP55 rating.

Variable Frequency Drive (VFD)

Dual speed controls via "under-the-cover" variable frequency drive for both single-phase and three-phase hoists. VFD includes count hour meter, load limiter and no-load high-speed function.

Long Life Friction Clutch

Protects hoist from damage and prevents overwinding.

Upper/Lower Limit Switch

Low profile upper and lower limit switches provide excellent headroom.

Unique Chain Guide

Provides quiet and smooth guiding of chain. Heavy cast iron construction for improved wear versus stamped steel design offered by many manufacturers.

Durable Push Button Pendant

Easy to use, one-handed operation. Rated IP65. Standard control voltage is 24V. Strain relief wire is molded to pendant cord for added support and dependability. E-Stop is standard on all pendants.

Extreme Duty Motor

Increased performance through 30/10-minute duty rating, H4 classification, Class B insulation, cooling fins and external thermal motor protection.

Load Sheave

Five deep-groove pockets fully support the load chain during operation. Reduces vibration and chain wear. Provides true vertical lift.

Operating Conditions

Recommended for -4° to +104°F and humidity of 85% or less.

Standard Motorized Trolley Specifications

Capacity Range

1/8 Ton – 1 Ton

Standard Voltage

(Re-connectable)
115-1-60
(220-230)-1-50/60

Control Voltage

24VDC

Duty Cycle*

30/10 Min.

Classification*

ASME H4
ISO 1/8-1/2T M6; 1T M5
FEM 1/8-1/2T 3m; 1T 2m

Ratings

Trolley – IP55
Pendant – IP65

Standard Pendants

4-button (momentary contacts) with emergency On/Off (maintained contacts)

Shafts

Standard shafts fit wide flange range
Longer shafts for wider beams
Spacers for easy adjustments

Drop Stops

Standard

Bumpers

Standard

Wheels

All steel
Shielded ball bearings
Fit flat or tapered beam flange

Standard Power Supply Length

30' (longer lengths available)

Standard Pendant Drop

Standard pendant hangs approximately 4' above the hoist's fully extended bottom hook (longer drops available)

*See page 79-81 for additional information.



SEQM010SD-SD

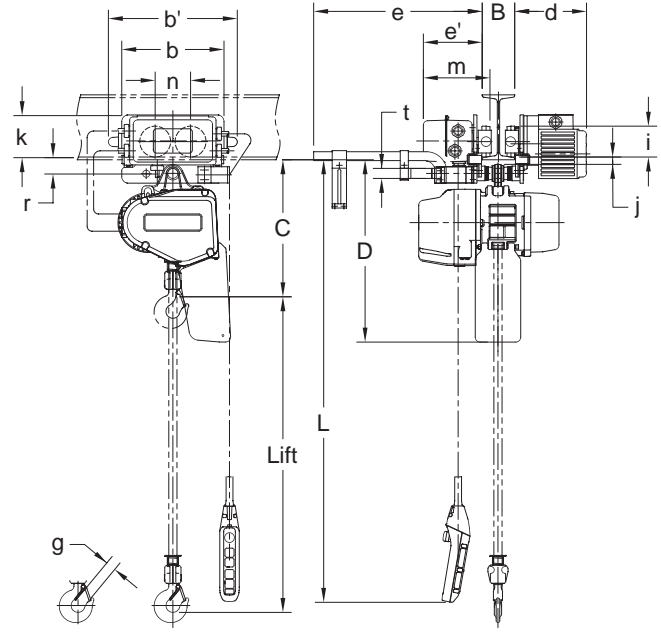

SEQM010SD-SD

SEQ 1-PHASE DUAL SPEED VFD HOIST WITH DUAL SPEED VFD TROLLEY — SPECIFICATIONS

Cap. (Tons)	Product Code	Std. Lift (ft)	Push Button Cord L (ft)	Lifting Speed ² (ft/min)			Hoist Data ¹ Single-Phase			Traversing Speed ² (ft/min)		Trolley Data ¹ Single-Phase			Flange Width Adjustability B (in)		Minimum ³ Allow. Radius for Curve (in)	Load Chain Diameter (mm) x Chain Fall Lines	Net Weight (lbs)	Weight for Additional One Foot of Lift (lbs)	
				High	Low	No Load High Speed	Output (Hp)	Rated Current (amps)		High	Low	Output (Hp)	Rated Current (amps)		Standard	Optional					
							@115V-60Hz	@220-230V-50/60Hz			@115V-60Hz	@220-230V-50/60Hz									
1/8	SEQM001SD-SD	10	8.2	56	9.2	72	0.67	11.0	7.1	80	13	0.54	4.5	2.1	2.28 to 6.02	6.03 to 12.00	31.5*	5.6 x 1	139	0.48	
1/4	SEQM003SD-SD			33	5.5	43		12.7	7.2										141		
1/2	SEQM005SD-SD			25	4.2	32		1.0	14.9										9.0		146
1	SEQM010SD-SD			17	3.9	30		2.0	19.5										12.0		165

1) Hoist and trolley are voltage re-connectable between 115/220-230V.
 2) Speeds are adjustable between low and high speed.
 3) *Flange widths smaller than 4 inches will have a minimum radius of 137.8 inches.

SEQ 1-PHASE DUAL SPEED VFD HOIST WITH DUAL SPEED VFD TROLLEY — DIMENSIONS

Cap. (Tons)	Product Code	Headroom C (in)	D (in)	b' (in)	b (in)	d (in)	e (in)	e' (in)	g (in)	i (in)	j (in)	k (in)	m (in)	n (in)	r (in)	t (in)
1/8	SEQM001SD-SD	16.5	20.3	15.6	12.4	8.7	20.3	7.1	1.1	3.7	1.1	5.1	8.1	4.3	2.0	1.2
1/4	SEQM003SD-SD															
1/2	SEQM005SD-SD															
1	SEQM010SD-SD	19.3	22.2						1.2		0.9					

SEQP and SEQG Electric Chain Hoists with Push or Geared Trolleys



SEQP010SD

Mounting Harrington's SEQ Series single-phase dual speed (VFD Control) electric chain hoist to our PT push or GT geared trolley will create an easy and economical method of transporting the load. This combination is ideal for workstations and short or infrequent moves.

Features and Benefits

Pull-Rotor Motor Brake

Extremely durable and reliable, this advanced design contains no brake coil to fail like conventional disc brakes.

External Motor Fan

Functions to quickly eliminate resistor, motor and brake heat. This results in improved hoist duty rating and greatly lengthens brake life. Motor is totally enclosed, fan cooled (TEFC).

Precision Machined Helical Gears

Immersed in oil bath lubrication results in quiet, smooth and cool operation.

Chain Container

Durable plastic containers are standard.

Corrosion Resistant Load Chain

Nickel-plated, Grade 80, DIN chain for superb durability and strength.

Forged Carbon Steel Hooks

Under excessive loads will open gradually and not fracture. Ball bearings produce smooth rotation. Bottom hook will swivel 360°. Heavy-duty hook latches are standard.

Compact Aluminum Body

Die-cast body is lightweight and offers low headroom – one of the best in the industry. Paint is electrostatically applied.

Completely Sealed Body

Suitable for both indoor and outdoor applications, including harsh environments. (Consult Owner's Manual for details.) Gaskets throughout the hoist provide for an IP55 rating.

Variable Frequency Drive (VFD)

Dual speed controls via "under-the-cover" variable frequency drive for both single-phase and three-phase hoists. VFD includes count hour meter, load limiter and no-load high-speed function.

Long Life Friction Clutch

Protects hoist from damage and prevents overwinding.

Upper/Lower Limit Switch

Low profile upper and lower limit switches provide excellent headroom.

Unique Chain Guide

Provides quiet and smooth guiding of chain. Heavy cast iron construction for improved wear versus stamped steel design offered by many manufacturers.

Durable Push Button Pendant

Easy to use, one-handed operation. Rated IP65. Standard control voltage is 24V. Strain relief wire is molded to pendant cord for added support and dependability. E-Stop is standard on all pendants.

Extreme Duty Motor

Increased performance through 30/10-minute duty rating, H4 classification, Class B insulation, cooling fins and external thermal motor protection.

Load Sheave

Five deep-groove pockets fully support the load chain during operation. Reduces vibration and chain wear. Provides true vertical lift.

Operating Conditions

Recommended for -4° to +104°F and humidity of 85% or less.

Standard Trolley Specifications

Capacity Range

1/8 Ton – 1 Ton

Shafts

Standard shafts fit wide range
Longer shafts for wider beams
Spacers for easy adjustments

Drop Stops

Standard

Bumpers

Optional

Standard Hand Chain Drop

Standard geared trolley hand chain hangs approximately 2' less than hoist's fully extended bottom hook (longer drops available)

Wheels

All steel
Sealed ball bearings
Fit flat or tapered beam flange

Standard Hoist Pendant Drop

Standard pendant hangs approximately 4' above the hoist's fully extended bottom hook (longer drops available)

Standard Hoist Power Supply Length

15' (longer lengths available)

Standard Pendants

2-button (momentary contacts) with emergency On/Off (maintained contacts)

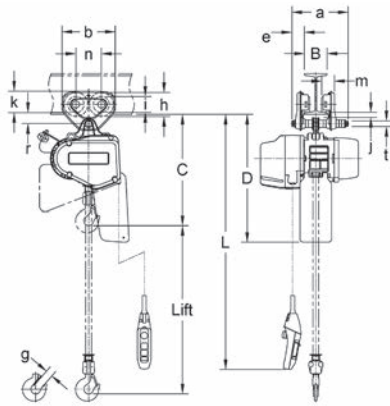

SEQP010SD

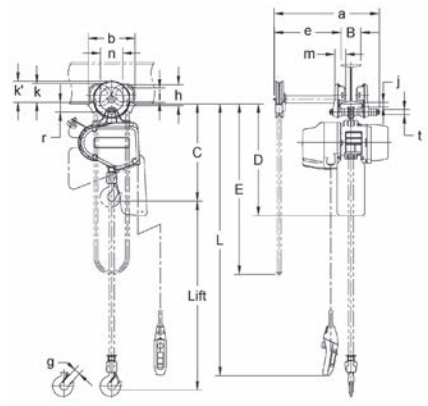

SEQG010SD

SEQ 1-PHASE DUAL SPEED VFD HOIST WITH PUSH OR GEARED TROLLEY — SPECIFICATIONS

Cap. (Tons)	Product Code	Standard Lift (ft)	Push Button Cord L (ft)	Lifting Speed ² (ft/min)			Hoist Data ¹ Single-Phase		Flange Width Adjustability ³ B (in)		Minimum Allow. Radius for Curve ^{3,4} (in)	Load Chain Diameter (mm) x Chain Fall Lines	Net Weight ³ (lbs)	Weight for Additional One Foot of Lift (lbs)	
				High	Low	No Load High Speed	Output (Hp)	Rated Current (amps)		Standard					Optional
								@115V-60Hz	@220-230V-50/60Hz						
1/8	SEQ(P/G)001SD	10	8.2	56	9.2	72	0.67	11.0	7.1	2.28 to 4.00 (2.28 to 5.00)	4.01 to 8.00 (5.01 to 8.00) OR 8.01 to 12.00	43.3 (51.2)	5.6 x 1	75 (97)	0.48
1/4	SEQ(P/G)003SD			33	5.5	43		12.7	7.2						
1/2	SEQ(P/G)005SD			25	4.2	32		1.0	14.9						
1	SEQ(P/G)010SD			17	3.9	30	2.0	19.5	12.0	2.28 to 5.00	5.01 to 8.00 OR 8.01 to 12.00	51.2	7.1 x 1	108 (123)	0.77

1) SEQ hoists are voltage re-connectable between 115/230V.
 2) Speeds are adjustable between low and high speed.
 3) Figures in parentheses are data for geared trolley if different than push trolley.
 4) Minimum Flange Width for curved beam: 1 Ton Push and 1/8 to 1 Ton Geared = 2.87 in.

SEQ 1-PHASE DUAL SPEED VFD HOIST WITH PUSH TROLLEY — DIMENSIONS

Cap. (Tons)	Product Code	Headroom C (in)	D (in)	a (in)	b (in)	e (in)	g (in)	h (in)	i (in)	j (in)	k (in)	m (in)	n (in)	r (in)	t (in)
1/8	SEQP001SD	16.3	19.9	10.4	7.2	1.8	1.1	3.2	2.4	0.75	3.0	1.9	3.3	1.5	0.87
1/4	SEQP003SD														
1/2	SEQP005SD														
1	SEQP010SD	19.3	22.2	11.2	9.3	2.2	1.2	4.2	2.8	0.98	3.7	2.2	4.4	2.0	0.98

SEQ 1-PHASE DUAL SPEED VFD HOIST WITH GEARED TROLLEY — DIMENSIONS

Cap. (Tons)	Product Code	Headroom C (in)	D (in)	E (ft)	a (in)	b (in)	e (in)	g (in)	h (in)	i (in)	j (in)	k (in)	k' (in)	m (in)	n (in)	r (in)	t (in)
1/8	SEQG001SD	16.7	20.3	10.5	20.9	9.3	13.3	1.1	4.2	2.8	1.1	3.7	4.2	2.2	4.4	2.0	0.98
1/4	SEQG003SD																
1/2	SEQG005SD																
1	SEQG010SD							19.3									