OWNER'S MANUAL

LEVER OPERATED CHAIN HOIST LB SERIES

MODEL L5

3/4 Ton through 9 Ton Capacity

Code, Lot and Serial Number

WARNING

This equipment should not be installed, operated or maintained by any person who has not read and understood all the contents of this manual. Failure to read and comply with the contents of this manual can result in serious bodily injury or death, and/or property damage.

HARRINGTON
A KITO GROUP COMPANY

Table of Contents

Section	Page Number
1.0 Important Information and Warnings	4
1.1 Terms and Summary	
1.2 Warning Tags and Labels	
2.0 Technical Information.....	7
2.1 Specifications	
2.2 Dimensions	
2.3 Optional Equipment	
3.0 Preoperational Procedures	12
3.1 Chain	
3.2 Attachment Points	
3.3 Mounting the Hoist	
3.4 Preoperational Checks and Trial Operation	
4.0 Operation	14
4.1 Introduction	
4.2 Shall's and Shall Not's for Operation	
4.3 Hoist Operation	
4.4 Load Limit Warning Handle Option	
4.5 Slip Clutch Option	
5.0 Inspection	21
5.1 General	
5.2 Inspection Classification	
5.3 Preoperational Inspection	
5.4 Frequent Inspection	
5.5 Periodic Inspection	

Section	Page Number
5.6	Occasionally Used Hoists
5.7	Inspection Records
5.8	Inspection Methods and Criteria
6.0	Maintenance & Handling 34
6.1	Lubrication
6.2	Disassembly, Assembly and Adjustment
6.3	Hoist Disassembly
6.4	Hoist Assembly
6.5	Chaining
6.6	Storage
6.7	Outdoor Installation
7.0	Troubleshooting 48
8.0	Warranty 53
9.0	Parts List 55

1.0 Important Information and Warnings

1.1 Terms and Summary

This manual provides important information for personnel involved with the installation, operation and maintenance of this product. Although you may be familiar with this or similar equipment, it is strongly recommended that you read this manual before installing, operating or maintaining the product.

Danger, Warning, Caution and Notice

Throughout this manual there are steps and procedures that can present hazardous situations. The following signal words are used to identify the degree or level of hazard seriousness.

⚠ DANGER Danger indicates an imminently hazardous situation which, if not avoided, **will** result in **death or serious injury**, and property damage.

⚠ WARNING Warning indicates an imminently hazardous situation which, if not avoided, **could** result in **death or serious injury**, and property damage.

⚠ CAUTION Caution indicates a potentially hazardous situation which, if not avoided, **may** result **minor or moderate injury** or property damage.

NOTICE Notice is used to notify people of installation, operation, or maintenance information which is important but not directly hazard-related.

⚠ CAUTION

These general instructions deal with the normal installation, operation, and maintenance situations encountered with the equipment described herein. The instructions should not be interpreted to anticipate every possible contingency or to anticipate the final system, crane, or configuration that uses this equipment. For systems using the equipment covered by this manual, the supplier and owner of the system are responsible for the system's compliance with all applicable industry standards, and with all applicable federal, state and local regulations/codes.

This manual includes instructions and parts information for a variety of hoist types. Therefore, all instructions and parts information may not apply to any one type or size of specific hoist. Disregard those portions of the instructions that do not apply.

Record your hoist's Code, Lot and Serial Number (see Section 9) on the front cover of this manual for identification and future reference to avoid referring to the wrong manual for information or instructions on installation, operation, inspection, maintenance, or parts.

Use only Harrington authorized replacement parts in the service and maintenance of this hoist.

WARNING

Equipment described herein is not designed for and **MUST NOT** be used for lifting, supporting, or transporting people, or for lifting or supporting loads over people.

Equipment described herein should not be used in conjunction with other equipment unless necessary and/or required safety devices applicable to the system, crane, or application are installed by the system designer, system manufacturer, crane manufacturer, installer, or user.

Modifications to upgrade, rerate, or otherwise alter this equipment shall be authorized only by the original equipment manufacturer.

If a below-the-hook lifting device or sling is used with a hoist, refer to ANSI/ASME B30.9, "Safety Standard for Slings" or ANSI/ASME B30.20, "Safety Standard for Below-the-Hook Lifting Devices".

Hoists used to handle hot molten material may require additional equipment or devices. Refer to ANSI Z241.2, "Safety Requirements for Melting and Pouring of Metals in the Metalcasting Industry".

Failure to read and comply with any one of the limitations noted herein can result in serious bodily injury or death, and/or property damage.

NOTICE

It is the responsibility of the owner/user to install, inspect, test, maintain, and operate a hoist in accordance with ANSI/ASME B30.21, "Manually Lever Operated Hoists" and OSHA Regulations. If the hoist is installed as part of a total lifting system, such as an overhead crane or monorail, it is also the responsibility of the owner/user to comply with the applicable ANSI/ASME B30 volume that addresses that type of equipment.

It is the responsibility of the owner/user to have all personnel that will install, inspect, test, maintain, and operate a hoist read the contents of this manual and applicable portions of ANSI/ASME B30.21, "Manually Lever Operated Hoists" and OSHA Regulations.

If the hoist owner/user requires additional information, or if any information in the manual is not clear, contact Harrington or the distributor of the hoist. Do not install, inspect, test, maintain, or operate this hoist unless this information is fully understood.

A regular schedule of inspection of the hoist in accordance with the requirements of ANSI/ASME B30.21 should be established and records maintained.

1.2 Warning Tags and Labels

The warning tag illustrated below in Figure 1-1 is supplied with each hoist shipped from the factory. If the tag is not attached to your hoist's no-load side of the load chain, order a tag from your dealer and install it. Read and obey all warnings attached to this hoist. Tag is not shown actual size.



2.0 Technical Information

2.1 Specifications

2.1.1 Product Code

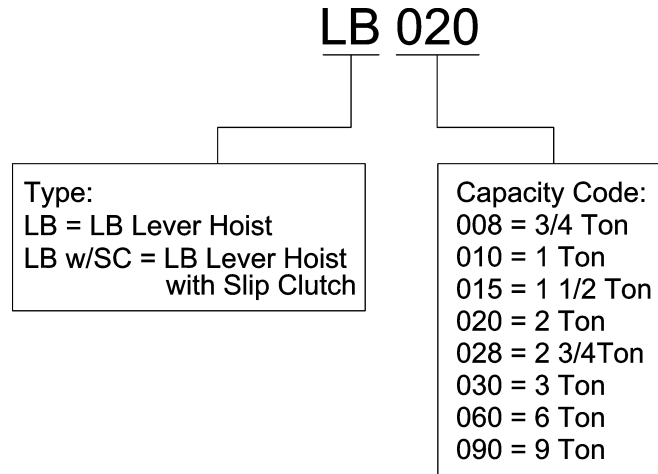

2.1.2 Operating Conditions and Environment

Temperature range: -40° to +140°F (-40° to +60°C)

Humidity: 100% or less (Not an Underwater Device)

Cap. (Tons)	Product Code	Std. Lift (ft)	Pull to Lift Load* (lbs)	Load Chain Diameter (mm) x Chain Fall Lines	Net Weight (lbs)	Shipping Weight Approx. (lbs)	Weight for Additional One Foot of Lift (lbs)
¾	LB008	5	54 (36)	5.6 x 1	13	13	0.5
1	LB010		72 (46)			14	
1½	LB015		64 (45)	7.1 x 1	18	18	0.7
2	LB020		59 (42)	8.8 x 1	25	26	1.1
2¾	LB028		81 (57)				
3	LB030		69	10.0 x 1	33	35	1.5
6	LB060		72	10.0 x 2	57	60	3.2
9	LB090		78	10.0 x 3	88	93	4.7

*Numbers in parentheses are for hoists with the optional load limit warning handle.

2.2 Dimensions

Table 2-2 Hoist Dimensions								
Cap. (Tons)	Product Code	a (in)	b (in)	Headroom C (in)	D* (in)	e (in)	f (in)	g (in)
¾	LB008	5.7	4.7	11.0	9.6 (14.4)	3.8	1.6	0.9
1	LB010			11.8				1.1
1½	LB015	6.3	5.0	13.2	10.4 (14.4)	3.9	1.5	1.3
2	LB020	6.8	5.9	14.8		4.0	1.8	1.4
2¾	LB028				1.5			
3	LB030	7.5	6.3	15.6	16.3 (16.9)	4.4	2.3	2.0
6	LB060		8.5	21.3				2.9
9	LB090		12.0	26.8				4.1

*Dimensions in parentheses are for hoists with the optional load limit warning handle.

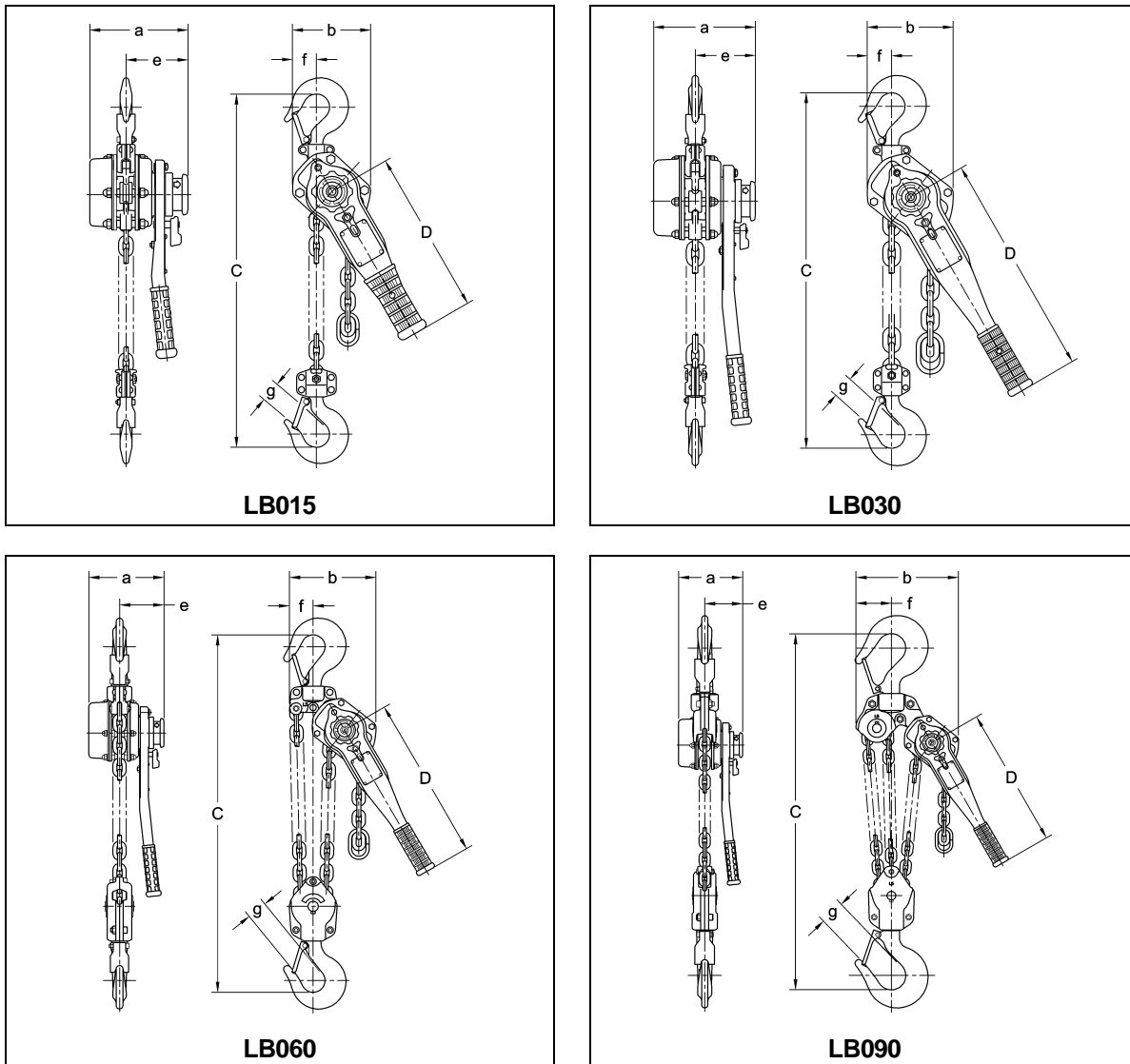
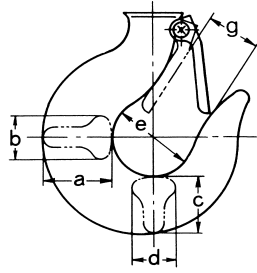

Figure 2-1 Hoist Dimensions (Refer Table 2-2)

Table 2-3 Hook Dimension*



T = Top Hook
 B = Bottom Hook
 Units = inch

Cap. (Tons)	Product Code	Hook	a	b	c	d	e	g
¾	LB008	T & B	0.9	0.6	0.8	0.6	1.4	0.93
1	LB010	T & B					1.7	1.14
1½	LB015	T & B	1.2	0.7	1.0	0.7	1.7	1.26
2	LB020	T & B	1.4	0.8	1.14	0.8	1.9	1.44
2¾	LB028							
3	LB030	T & B	1.6	1.0	1.2	1.0	2.0	1.54
6	LB060	T & B	2.1	1.3	1.6	1.3	2.4	1.97
9	LB090	T & B	2.6	1.6	2.0	1.6	3.4	2.85

*Refer to Section 5.7 for inspection dimensions and limits.

2.3 Optional Equipment

2.3.1 Load Limit Warning Handle (LLWH)

- **⚠ WARNING** Refer to Section 4.4 for detailed LLWH information.

2.3.2 Shipyard Hooks (SYH)

- The SYH is a special hook with a heavier design for use in the metal and ship building industries. They are designed to aid in the effective positioning of fixtures and steel plate before welding. Hook latches are included with all SYH. Refer to Figure 2-2.
- **⚠ WARNING** Shipyard Hook is designed for tip loading. Improper use could result in death or serious injury. To avoid these hazards:
 - Follow the hoist operating instructions in Section 4.0.
 - Read and understand all instructions before using.
 - Follow instructions on all related warning tags.
 - Make sure the Shipyard Hook is secure so it can not unintentionally disengage from load.
- The SYH is available in Top and Bottom versions and in two sizes: 1½ and 3 Tons.
- A yoke is included with the SYH. See Section 9.3, Parts List for a complete SYH part listing.

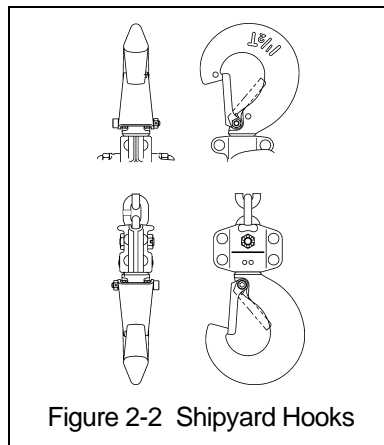

Figure 2-2 Shipyard Hooks

2.3.3 Top Hook Extender

- The Top Hook Extender is designed to move the hoist body away from the attachment point. It can be used to place the hoist lower in vertical application or increase the hoist reach in horizontal applications. Refer to Figure 2-3.
- The Top Hook Extender Parts Kit contains a hook set, chain, top and bottom yokes, extension block and all necessary hardware. Kits are available for LB008 through LB030 hoists.
- The standard extender chain length is 18 inches; other lengths are available up on request.
- The extender chain is the same size and grade Harrington chain as is used on the hoist.
- Top Hook Extender can be acquired upon request with Latch Lock, Inspection or Ship Yard type hooks.
- See Section 9.3, Parts List for a complete Top Hook Extender part listing.

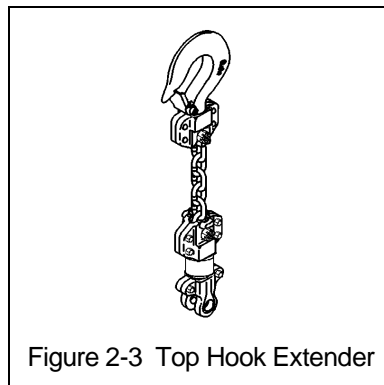
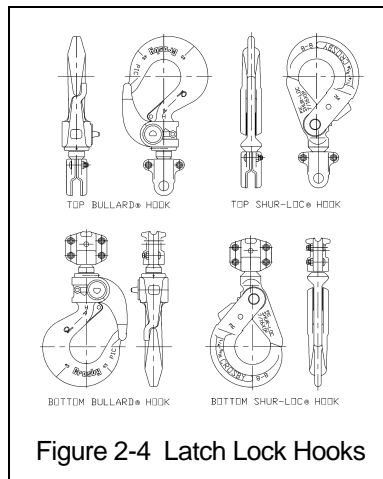

Figure 2-3 Top Hook Extender

2.3.4 Latch Lock Hooks

- The Bullard® hook has a conventional hook shape with a special, heavy-duty, rotating, spring-loaded, locking latch. The latch remains locked until it is released by the operator.
- The Shur-Loc® hook is a special design hook where the latch remains fixed and the hook swings to unlock. The hook cannot be opened while a load is applied.
- Installation of these hooks may change the headroom.
- See Section 9.3, Parts List for a complete Latch Lock Hook part listing.



2.3.5 Inspection Hooks

- The Inspection Hook is designed to facilitate the inspection of the internal surfaces of the hook yoke and shank portion of the hook itself. The Inspection Hook is suitable for applications where inspection of the internal parts of the hook set is required. The inspection hook uses the standard Harrington hook set and is assembled with high-strength locking fasteners instead of rivets. Inspection hooks are available in top and bottom versions. Refer to Figure 2-5.
- Disassembly and re-assembly involves removal and reinstallation of the yoke fasteners of the Inspection Hook Set Assembly followed by testing of the hoist prior to returning it to service.
- The Inspection Hook is available for LB008 through LB030 hoists.
- See Section 9.3, Parts List for a complete Inspection Hook part listing.

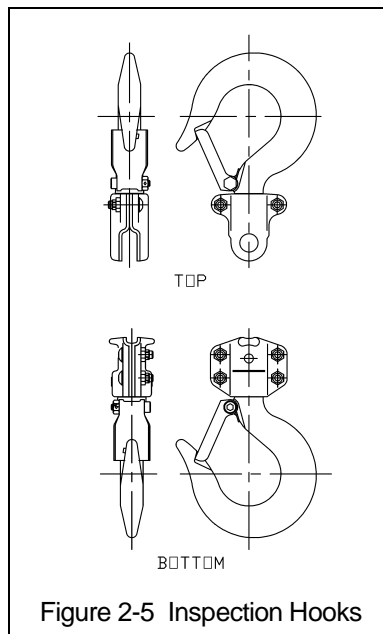

2.3.6 Slip Clutch

- **⚠ WARNING** Refer to Section 4.5 for detailed Slip Clutch information.

3.0 Preoperational Procedures

3.1 Chain

3.1.1 **⚠ WARNING** A chain stopper link must be installed on the second to last chain link on the no-load end of the load chain.

3.1.2 **⚠ WARNING** Verify that the load chain is not twisted or tangled prior to operating the hoist. Make sure the bottom hook on the 6 (LB060) and 9 (LB090) Ton multiple fall hoists is not capsized. See Figures 3-1 and 3-2. Correct all chain irregularities before conducting the first hoist operation.

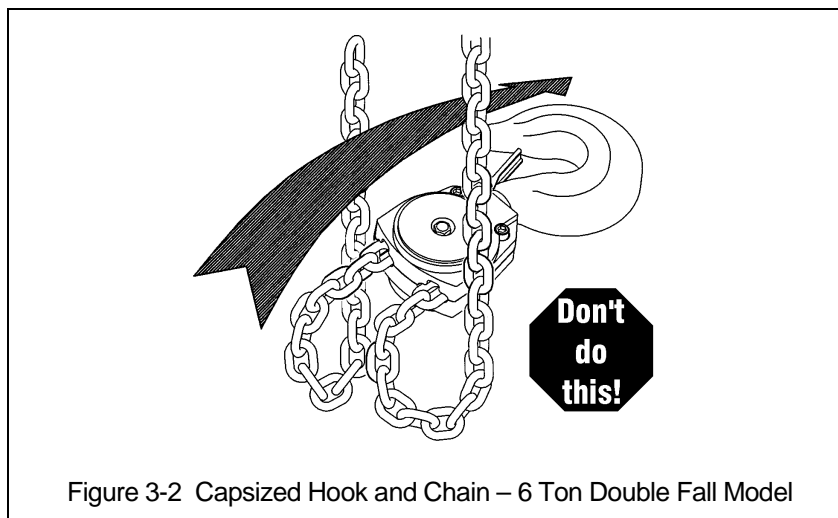
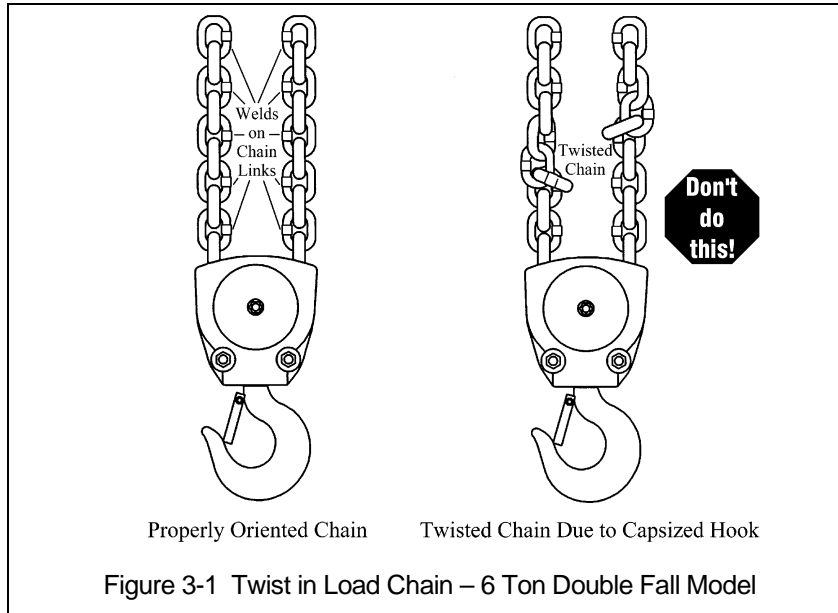

3.1.3 **⚠ CAUTION** Model L4 and Model L5 chain is not interchangeable.

3.2 Attachment Points

3.2.1 **⚠ WARNING** Prior to attaching the hoist ensure that all attachment points, suspension components and supporting structure are adequate to support the hoist and its load. If necessary consult a professional that is qualified to evaluate the adequacy of the suspension location and its supporting structure.

3.2.2 **NOTICE** See Section 6.6 for outdoor installation considerations.

3.3 Mounting the Hoist

3.3.1 Hook Mounted to a Fixed Location - Attach the hoist's top hook to the fixed suspension point.

3.3.2 **⚠ WARNING** Ensure that the fixed suspension point rests on the center of the hook's saddle and that the hook's latch is engaged.

3.4 Preoperational Checks and Trial Operation

3.4.1 **⚠ WARNING** Confirm the adequacy of the rated capacity for all slings, chains, wire ropes and all other lifting attachments before use. Inspect all load suspension members for damage prior to use and replace or repair all damaged parts.

3.4.2 **⚠ WARNING** Verify and correct all chain irregularities prior to operating the hoist. Refer to Section 3.1.

3.4.3 Measure and record the "k" dimension of all hooks on hoist. See Table 5-10 under Section 5, "Inspection".

3.4.4 Record the hoist's Code, Lot and Serial Number (from the name plate on the hoist; see Section 9) in the space provided on the cover of this manual.

3.4.5 Ensure that the hoist is properly installed to a fixed point.

3.4.6 Ensure that all nuts, bolts and split pins (cotter pins) are sufficiently fastened.

3.4.7 Confirm proper operation.

- Before operating read and become familiar with Section 4 - Operation.
- Before operating ensure that the hoist meets the Inspection, Testing and Maintenance requirements of ANSI/ASME B30.21.
- Before operating ensure that nothing will interfere with the full range of the hoist's operation.

4.0 Operation

4.1 Introduction

DANGER

DO NOT WALK UNDER A SUSPENDED LOAD

WARNING

HOIST OPERATORS SHALL BE REQUIRED TO READ THE OPERATION SECTION OF THIS MANUAL, THE WARNINGS CONTAINED IN THIS MANUAL, INSTRUCTION AND WARNING LABELS ON THE HOIST OR LIFTING SYSTEM, AND THE OPERATION SECTIONS OF ANSI/ASME B30.21 and ANSI/ASME B30.10. THE OPERATOR SHALL ALSO BE REQUIRED TO BE FAMILIAR WITH THE HOIST AND HOIST CONTROLS BEFORE BEING AUTHORIZED TO OPERATE THE HOIST OR LIFTING SYSTEM.

HOIST OPERATORS SHOULD BE TRAINED IN PROPER RIGGING PROCEDURES FOR THE ATTACHMENT OF LOADS TO THE HOIST HOOK.

HOIST OPERATORS SHOULD BE TRAINED TO BE AWARE OF POTENTIAL MALFUNCTIONS OF THE EQUIPMENT THAT REQUIRE ADJUSTMENT OR REPAIR, AND TO BE INSTRUCTED TO STOP OPERATION IF SUCH MALFUNCTIONS OCCUR, AND TO IMMEDIATELY ADVISE THEIR SUPERVISOR SO CORRECTIVE ACTION CAN BE TAKEN.

HOIST OPERATORS SHOULD HAVE NORMAL DEPTH PERCEPTION, FIELD OF VISION, REACTION TIME, MANUAL DEXTERITY, AND COORDINATION.

HOIST OPERATORS SHOULD **NOT** HAVE A HISTORY OF OR BE PRONE TO SEIZURES, LOSS OF PHYSICAL CONTROL, PHYSICAL DEFECTS, OR EMOTIONAL INSTABILITY THAT COULD RESULT IN ACTIONS OF THE OPERATOR BEING A HAZARD TO THE OPERATOR OR TO OTHERS.

HOIST OPERATORS SHOULD **NOT** OPERATE A HOIST OR LIFTING SYSTEM WHEN UNDER THE INFLUENCE OF ALCOHOL, DRUGS, OR MEDICATION.

NOTICE

- Read ANSI/ASME B30.21 and ANSI/ASME B30.10.
- Read the hoist manufacturer's Operating and Maintenance Instructions.
- Read all labels attached to equipment.

The operation of a hoist involves more than activating the hoist's controls. Per the ANSI/ASME B30 standards, the use of a hoist is subject to certain hazards that cannot be mitigated by engineered features, but only by the exercise of intelligence, care, common sense, and experience in anticipating the effects and results of activating the hoist's controls. Use this guidance in conjunction with other warnings, cautions, and notices in this manual to govern the operation and use of your hoist.

4.2 Shall's and Shall Not's for Operation

WARNING

Improper operation of a hoist can create a potentially hazardous situation which, if not avoided, could result in death or serious injury, and substantial property damage. To avoid such a potentially hazardous situation **THE OPERATOR SHALL:**

- **NOT** lift more than rated load for the hoist.
- **NOT** use damaged hoist or hoist that is not working properly.
- **NOT** use hoist with twisted, kinked, damaged, or worn chain.
- **NOT** use hoist if the bottom hook is capsized (multiple fall hoists - see Section 3.1).
- **NOT** use the hoist to lift, support, or transport people.
- **NOT** lift loads over people.
- **NOT** apply load unless load chain is properly seated in the load sheave (and idle sheave for hoist with multiple chain falls).
- **NOT** use the hoist in such a way that could result in shock or impact loads being applied to the hoist.
- **NOT** attempt to lengthen the load chain or repair damaged load chain.
- **NOT** operate hoist when it is restricted from forming a straight line from hook to hook in the direction of loading.
- **NOT** use load chain as a sling or wrap load chain around load.
- **NOT** use hoist with extension on lever handle.
- **NOT** apply load if binding prevents equal loading on all load-supporting chains.
- **NOT** operate beyond the limits of the load chain travel.
- **NOT** support load on hook tip unless hook is designed for tip loading.
- **NOT** use in a way that causes either hook to be side-loaded.
- **NOT** leave load supported by the hoist unattended unless specific precautions have been taken.
- **NOT** allow the chain, or hook to be used as an electrical or welding ground.
- **NOT** allow the chain, or hook to be touched by a live welding electrode.
- **NOT** remove or obscure the warnings on the hoist.
- **NOT** operate a hoist on which the safety placards or decals are missing or illegible.
- Be familiar with operating controls, procedures, and warnings.
- Make sure the unit is securely attached to a suitable support before applying load.
- Make sure load slings or other approved single attachments are properly sized, rigged, and seated in the hook saddle.
- Take up slack carefully - make sure load is balanced and load-holding action is secure before continuing.
- Make sure all persons stay clear of the supported load.
- Protect the hoist's load chain from weld splatter or other damaging contaminants.
- Report Malfunctions or unusual performances (including unusual noises) of the hoist and remove the hoist from service until the malfunction or unusual performance is resolved.
- Warn personnel before lifting or moving a load.
- Warn personnel of an approaching load.

CAUTION

Improper operation of a hoist can create a potentially hazardous situation which, if not avoided, could result in minor or moderate injury, or property damage. To avoid such a potentially hazardous situation **THE OPERATOR SHALL:**

- Maintain a firm footing or be otherwise secured when operating the hoist.
- Check brake function by tensioning the hoist prior to each lift operation.
- Use hook latches. Latches are to retain slings, chains, etc. under slack conditions only.
- Make sure the hook latches are closed and not supporting any parts of the load.
- Make sure the load is free to move and will clear all obstructions.
- Avoid swinging the load or hook.
- Make sure hook travel is in the same direction as shown on controls.
- Inspect the hoist regularly, replace damaged or worn parts, and keep appropriate records of maintenance.
- Use the hoist manufacturer's recommended parts when repairing the unit.
- Lubricate load chain per hoist manufacturer's recommendations.
- **NOT** use the hoist load limiting or warning device to measure load.
- **NOT** allow your attention to be diverted from operating the hoist.
- **NOT** allow the hoist to be subjected to sharp contact with other hoists, structures, or objects through misuse.
- **NOT** adjust or repair the hoist unless qualified to perform such adjustments or repairs.

4.3 Hoist Operation

4.3.1 Free Chain Principle

- Free chaining allows the load chain to be moved freely because the brake is released under no load situations.
- Pulling the free knob actuates the internal spring to release the mechanical brake allowing the load chain to be pulled in either direction to the desired length. Refer to Figure 4-1.
- The brake is engaged during lowering or lifting the load.

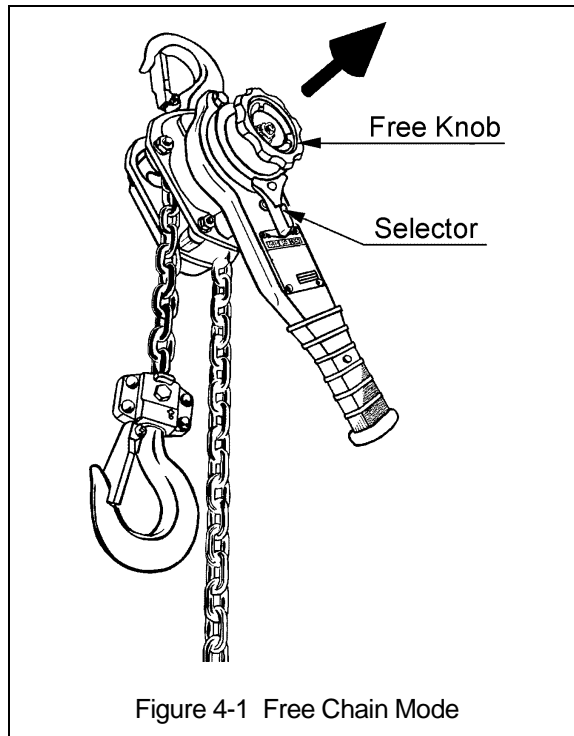

4.3.2 Free Chain Operation

- 1) **⚠ DANGER** Do not operate the hoist Free Knob while a load is applied to the hoist.
- 2) **⚠ DANGER** Do not touch the hoist Free Knob during lifting or lowering of the load.
- 3) **⚠ WARNING** Always check that the selector is placed in the proper position.
- 4) Set the Selector to the "N" position. The Selector is located under the Free Knob on the hand lever.
- 5) Pull the Free Knob out. The Free Knob turns counterclockwise and "snaps" out.
- 6) Pull the load chain to move the hook to the desired position.
- 7) **⚠ CAUTION** Do not pull the load chain suddenly in free chain mode. Excessive pulling may set the brake and not allow the load chain to move. If this occurs the hoist must be reset.
- 8) To reset the hoist to operate, rotate the Free Knob clockwise while pulling lightly on the load side chain. Once slack is removed, the Free Knob "snaps" in. This resets the brake and allows the hoist to be operated with the hand lever.

- 4.3.3 Lifting and Lowering Operation – Operating the lever with the selector set to the lifting “UP” or the lowering “DN” position, the hoist performs as follows:
- Set the selector to the direction of load movement desired and ratchet the lever back and forth. Refer to Table 4-1.
 - In lifting mode, the mechanical brake is engaged and supports the load on the pawls when the lever stops.
 - In lowering mode, lever operation releases the mechanical brake and lowers the load, when the lever stops, the mechanical brake is engaged and supports the load.
 - The brake is always engaged in the lifting and lowering modes.
 - If hand lever movement does not produce lifting, pull down the load side of the load chain while ratcheting until load chain slack is removed.

Table 4-1 Hoist Lever Operation		
Selector Position	Lever Rotation	Load Movement
UP	Clockwise	Lift
DN	Counterclockwise	Lower

- 4.3.4 **⚠ DANGER** Do not operate the free chain knob in lifting or lowering.
- 4.3.5 **⚠ CAUTION** Before operating, make sure that the hoist is not in the free chain mode and the selector is in the correct operating position.
- 4.3.6 **⚠ CAUTION** Under no load conditions, in the case that the load chain does not lower against your lowering operation, operate the grip with the load-side chain pulled lightly.

4.4 Load Limit Warning Handle (LLWH) Option

- 4.4.1 The LLWH is designed as a load detecting device to warn an operator that an excessive load has been applied to the hoist.
- 4.4.2 The LLWH is used for applications that require a load sensing feature that actuates within 10% of its setting. Exceeding the lever pull force limit (related to 100 to 120 % of the rated capacity) compresses the spring and deflects the lever grip. The LLWH deflects 15 degrees and registers a visual red signal to indicate that its setting has been reached. Refer to Table 4-2.
- 4.4.3 **⚠ DANGER** Disregarding the overload sign could cause bodily harm or damage to the hoist. Do not lift an overload.
- 4.4.4 **⚠ CAUTION** Do not allow dust or foreign objects to get into the LLWH.
- 4.4.5 **⚠ WARNING** Never adjust the signal setting to greater than 100 to 120 % of the rated capacity.
- 4.4.6 Excessive impact on the lever may result in a malfunctioning signal or damage to the components.
- 4.4.7 Using the hoist recklessly may cause the LLWH to work improperly.

Table 4-2 Signal Warnings		
Signal Color	Load Status	INSTRUCTIONS
Green	Safe Load	Continue Operation
Red	Overload	Do Not Continue Operation

4.4.8 Load Limit Warning Handle Operation

- Operate the hoist by holding the middle of the lever grip.
- The following three (3) signals occur to warn of an excessive load. Refer to Figure 4-2.
 - The lever grip **DEFLECTS**.
 - The lever **CLICKS**.
 - The signal window changes from **GREEN** to **RED**.
- Stop lifting and lowering immediately when an overload is detected.
- Reset the grip into its straight position (back in place) before continuing to operate the hoist.

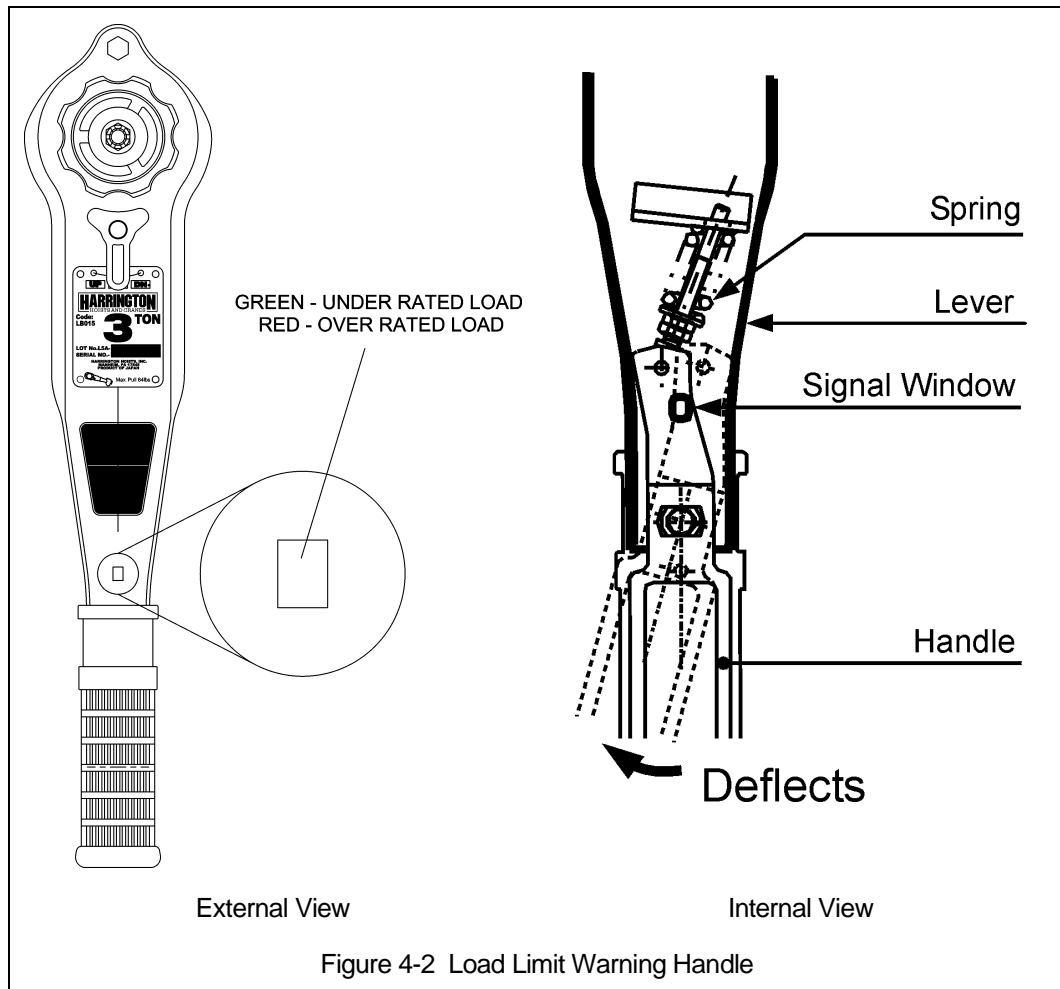

4.5 Slip Clutch Option

4.5.1 Slip Clutch Operation

- The L5 Lever Hoist with Slip Clutch is identified as is shown in Figure 4-3.
- The L5 Lever Hoist with Slip Clutch is designed and manufactured to warn an operator of a dangerous overload while preventing damage to the hoist.
- A greater than rated load will activate the Slip Clutch. This will cause the lever operation to slip preventing damage to the product.



Figure 4-3 Slip Clutch Identifier Label

- If the Slip Clutch is activated, immediately stop the lifting operation and ensure that the lever hoist is in a no load state.
- Follow the Owner’s Manual to operate the lever hoist in a normal manner.

4.5.2 Slip Clutch Operation Precautions

- **⚠ WARNING** Do not lift more than the rated load.
- **⚠ WARNING** When the Slip Clutch is activated, stop operating the hoist immediately. Failure to follow this instruction may cause injury or damage to the product. Reduce the load to less than the rated load. Warn all the surrounding people until the Slip Clutch is released.
- **⚠ WARNING** Do not use the hoist in a manner that frequently or repeatedly activates the Slip Clutch.
- **⚠ WARNING** Do not disassemble the lever hoist or change the Slip Clutch setting.
- **⚠ WARNING** Operating the lever hoist in an unsafe manner may cause the Slip Clutch to work improperly.
- **⚠ CAUTION** Using the lever hoist for a long period in an atmosphere of high oil content may cause the Slip Clutch to activate with less than the rated load.
- **⚠ CAUTION** If the Slip Clutch is activated with the rated load, contact the factory.

4.5.3 Slip Clutch Inspection and Maintenance

- Frequent Inspection - Follow the procedure listed in the L5LB Owner’s Manual.
- Periodic Inspection and Hoist Disassembly – Consult factory before performing any inspections or repairs involving disassembly and re-assembly of the hoist.

5.0 Inspection

5.1 General

- 5.1.1 The inspection procedure herein is based on ANSI/ASME B30.21. The following definitions are from ANSI/ASME B30.21 and pertain to the inspection procedure below.
- **Personnel Competence** – Persons performing the functions identified in this volume shall meet the applicable qualifying criteria stated in this volume and shall through education, training, experience, skill, and physical fitness, as necessary, be competent and capable to perform the functions as determined by the employer or employer’s representative.
 - **Qualified Person** – a person who, by possession of a recognized degree or certificate of professional standing, or who, by extensive knowledge, training, and experience, has successfully demonstrated the ability to solve or resolve problems relating to the subject matter and work.
 - **Normal Service** – that distributed service which involves operation with randomly distributed loads within the rated load limit, or uniform loads less than 65% of rated load for not more than 15% of the time.
 - **Heavy Service** – that service which involves operation within the rated load limit which exceeds normal service.
 - **Severe Service** – that service which involves normal or heavy service with abnormal operating conditions.

5.2 Inspection Classification

- 5.2.1 Inspection Classification – the inspection procedure for hoists in regular service is divided into three general classifications based upon the intervals at which inspection is to be performed. The intervals in turn are dependent upon the nature of the critical components of the hoist and the degree of their exposure to wear, deterioration, or malfunction. The three general classifications are herein designated as PREOPERATIONAL, FREQUENT and PERIODIC, with respective intervals between inspections as defined below.
- 5.2.2 Initial Inspection – prior to initial use, all new, altered, or modified hoists shall be inspected per the Frequent Inspection criteria in Table 5-2.
- 5.2.3 PREOPERATIONAL Inspection – Visual inspection performed before the first use of each shift with records not required.
- 5.2.4 FREQUENT Inspection – visual examinations by the operator or other designated personnel with intervals per the following criteria:
- Normal service – monthly
 - Heavy service – weekly to monthly
 - Severe service – daily to weekly
 - Special or infrequent service – as recommended by a qualified person before and after each occurrence.
- 5.2.5 PERIODIC Inspection – visual inspection by a designated person with intervals per the following criteria:
- Normal service – yearly
 - Heavy service – semiannually
 - Severe service – quarterly
 - Special or infrequent service – as recommended by a qualified person before the first such occurrence and as directed by the qualified person for any subsequent occurrences.

5.3 Preoperational Inspection

5.3.1 Visual inspections shall be made before the first use of each shift with records not required.

Table 5-1 Preoperational Inspection
All functional operating mechanisms for proper operation and adjustment, maladjustment and unusual sounds.
Hooks and latches in accordance with ANSI/ASME B30.10, Frequent Inspection (paras. 10-1.10.3 and 10-2.10.3).
Load chain in accordance with Section 5.7
Over-travel restraint for proper attachment.
Hoist body and lever for deformation, cracks and /or other damage.
Hoist support or trolley, if used, for damage.

5.4 Frequent Inspection

5.4.1 Inspections shall be made on a FREQUENT basis in accordance with Table 5-2, "Frequent Inspection." Included in these FREQUENT Inspections are observations made during operation for any defects or damage that might appear between Periodic Inspections. Evaluation and resolution of the results of FREQUENT Inspections shall be made by a designated person such that the hoist is maintained in safe working condition.

Table 5-2 Frequent Inspection
All functional operating mechanisms for proper operation and adjustment, maladjustment and unusual sounds.
Hoist braking system for proper operation
Hooks and latches in accordance with ANSI/ASME B30.10, Frequent Inspection (paras. 10-1.10.3 and 10-2.10.3).
Load chain in accordance with Section 5.7
Load chain reeving for compliance with Section 3.1 and 6.4
Hoist body and lever for deformation, cracks, and/or other damage
Hoist support or trolley, if used, for damage

5.5 Periodic Inspection

5.5.1 Inspections shall be made on a PERIODIC basis in accordance with Table 5-3, "Periodic Inspection." Evaluation and resolution of the results of PERIODIC Inspections shall be made by a designated person such that the hoist is maintained in safe working condition.

5.5.2 For inspections where load suspension parts of the hoist are disassembled, a load test per ANSI/ASME B30.21 must be performed on the hoist after it is re-assembled and prior to its return to service.

Table 5-3 Periodic Inspection
Requirements of Frequent Inspection.
Hooks and latches in accordance with ANSI/ASME B30.10, Periodic Inspection (paras. 10-1.10.4 and 10-2.10.4).
Evidence of loose bolts, nuts, or rivets.
Evidence of worn, corroded, cracked, or distorted parts such as load blocks, suspension housing, chain attachments, clevises, yokes, suspension bolts, shafts, gears, bearings, pins, rollers and locking and clamping devices.
Evidence of damage to hook retaining nuts or collars and pins, and welds or rivets used to secure the retaining members.
Evidence of damage or excessive wear of load and idler sheaves.
Evidence of worn, glazed or oil contaminated friction disks; worn pawls, cams or ratchet; corroded, stretched, or broken pawl springs in brake mechanism.
Evidence of damage to supporting structure or trolley, if used, for damage
Function label on hoist for legibility.
Warning label properly attached to the hoist and legible (see Section 1.2).
End connections of load chain stopper link.
Evidence of missing hoist and hoist mounting items.

5.6 Occasionally Used Hoists

5.6.1 Hoists that are used infrequently shall be inspected as follows prior to placing in service:

- Hoist Idle More Than 1 Month, Less Than 1 Year: Inspect per FREQUENT Inspection criteria in Section 5.4.
- Hoist Idle More Than 1 Year: Inspect per PERIODIC Inspection criteria in Section 5.5., or as determined by a qualified person.

5.7 Inspection Records

5.7.1 Conditions found during Periodic Inspections shall be documented to provide the basis for a continuing evaluation. An external coded mark on the hoist is an acceptable identification in lieu of records. (A metal stamp mark shall not be made in a highly stressed area).

5.7.2 A long range chain inspection program should be established and should include records of examination of chains removed from service so a relationship can be established between visual observation and actual condition of the chain.

5.8 Inspection Methods and Criteria

5.8.1 This section covers the inspection of specific items. The list of items in this section is based on those listed in ANSI/ASME B30.21 for the Frequent and Periodic Inspection.

5.8.2 Frequent Inspection - Not intended to involve disassembly of the hoist. Disassembly for further inspection would be required only if frequent inspection results so indicate. Disassembly and further inspection should only be performed by a qualified person trained in the disassembly and re-assembly of the hoist.

5.8.3 Periodic Inspection - Disassembly of the hoist is required. Disassembly should only be performed by a qualified person trained in the disassembly and re-assembly of the hoist.

Table 5-4 Hoist Inspection Methods and Criteria

Item	Method	Criteria	Action
Functional operating mechanisms.	Visual, Auditory	Mechanisms should be properly adjusted and should not produce unusual sounds when operated. Components should not be deformed, scarred or show significant wear. Refer to Figures 5-1 and 5-2.	Repair or replace as required.
Braking System – Components	Visual	Brake Pawl, Pawl Shaft and Pawl Spring should not be deformed, scarred or show significant wear. Refer to Figures 5-1 and 5-3.	Replace
Braking System – Friction Plate	Visual, Measure	The surface of the friction plate should be free of grease, oil, scars, gouges and wear and have uniform thickness. The outer thickness should not be thinner than the inner thickness. The thickness should not be less than the discard value listed in Table 5-5.	Replace
Braking System – Friction Disc	Visual	The surface of the friction plate should be free of scars, gouges and wear.	Replace
Braking System – Bushing	Measure	The bushing should have uniform thickness. The “A” dimension should not be less than the discard value listed in Table 5-6.	Replace
Braking System – Bushing	Visual	When slightly heated, the bushing should be so lubricated that lubricant oozes off the surface.	Soak bushing in machine oil for one day.
Braking System – Ratchet Disc	Measure	The “D” dimension should not be less than the discard value listed in Table 5-7.	Replace
Lifting System – Components	Visual	Components should not be deformed, scarred or show significant wear. Refer to Figure 5-4.	Replace
Lifting System – Selector Pawl Spring	Measure	The “L” dimension should not be less than the listed in Table 5-8.	Replace
Lifting System – Brake Spring	Measure	The “L” dimension should not be less than the listed in Table 5-9. The “A” angle degree should not be greater than the discard value listed in Table 5-9.	Replace
Lifting System – Free Chain Spring	Measure	The “L” dimension should not be less than the discard value listed in Table 5-10. The “A” angle degree should not be less than the discard value listed in Table 5-10.	Replace
Hooks - Surface Condition	Visual	Should be free of gouges, deep nicks, dents, weld splatter and significant corrosion.	Replace.
Hooks - Fretting wear	Measure	The "u" and "t" dimensions should not be less than discard value listed in Table 5-11.	Replace.
Hooks - Stretch	Measure	The "k" dimension should not be greater than 1.05 times that measured and recorded at the time of purchase (See Section 3.4). If recorded "k" values are not available for hooks when new, use nominal "k" values from Table 5-11.	Replace.
Hooks - Deformation	Visual	Should be free of twists and deformations. See Figure 5-5.	Replace

Table 5-4 Hoist Inspection Methods and Criteria			
Item	Method	Criteria	Action
Hooks - Bent Shank or Neck	Visual	Shank and neck portions of hook should be free of deformations.	Replace.
Hooks - Swivel	Visual, Function	Bearing parts and surfaces should not show significant wear, and should be free of dirt, grime and deformations. Hook should rotate freely with no roughness. See Figure 5-5.	Clean/lubricate, or replace as required.
Hooks - Idle Sheave and Shaft (Multiple Fall Hoist)	Visual, Function	Pockets of Idle Sheave should be free of significant wear. Idle Sheave surfaces should be free of nicks, gouges, dirt and grime. Bearing parts and surfaces of Idle Sheave and Axle should not show significant wear. Idle Sheave should rotate freely with no roughness or significant free play.	Clean/lubricate, or replace as required.
Hooks - Hook Latches	Visual, Function	Latch should not be deformed. Attachment of latch to hook should not be loose. Latch spring should not be missing and should not be weak. Latch movement should not be stiff - when depressed and released latch should snap smartly to its closed position.	Replace.
Hooks - Yoke Assembly	Visual	Should be free of significant rust, weld splatter, nicks, gouges. Holes should not be elongated, fasteners should not be loose, and there should be no gap between mating parts.	Tighten or replace as required.
Top Pin – Deformation	Visual, Measure	The pin should be free of scars or significant deformation. The "d" dimension should not be less than discard value listed in Table 5-12.	Replace
Yoke – Top Pin Hole Deformation	Visual, Measure	The "d" dimension of the top pin hole should not be greater than the discard value listed in Table 5-13.	Replace Hook Set
Yoke – Chain Pin Hole Deformation	Measure	The "d" dimension of the chain pin hole should not be greater than the discard value listed in Table 5-13.	Replace Hook Set or yoke.
Load Chain - Surface Condition	Visual	Should be free of gouges, nicks, dents, weld splatter and corrosion. Links should not be deformed, and should not show signs of abrasion. Surfaces where links bear on one another should be free of significant wear.	Replace.
Load Chain - Pitch and Wire Diameter	Measure	The "P" dimension should not be greater than discard value listed in Table 5-14. The "d" dimension should not be less than discard value listed in Table 5-14.	Replace. Inspect Load Sheave (and Idle Sheave for multiple fall hoists).
Load Chain - Lubrication	Visual, Auditory	Entire surface of each chain link should be coated with lubricant and should be free of dirt and grime. Chain should not emit cracking noise when hoisting a load.	Clean/lubricate (see Section 6.0).
Load Chain - Reeving	Visual	Chain should be reeved properly through Load Sheave. Refer to Section 6.4. On multiple fall hoists chain should be installed properly and free of twists. Refer to Section 3.1.	Reeve/Install chain properly.

Table 5-4 Hoist Inspection Methods and Criteria			
Item	Method	Criteria	Action
Chain Pin - Deformation	Visual, Measure	The pin should be free of scars or significant deformation. The "d" dimension should not be less than discard value listed in Table 5-15.	Replace
Housing and Mechanical Components	Visual, Auditory, Function	Hoist components including load blocks, suspension housing, chain attachments, clevises, yokes, suspension bolts, shafts, gears, bearings, pins and rollers should be free of cracks, distortion, significant wear and corrosion. Evidence of same can be detected visually or via detection of unusual sounds during operation.	Replace.
Bolts, Nuts and Rivets	Visual, Check with Proper Tool	Bolts, nuts and rivets should not be loose, deformed or corroded.	Tighten or replace as required.
Load Sheave	Visual	Pockets of Load Sheave should be clean and free of significant wear.	Replace.
Warning Labels	Visual	Warning Labels should be affixed to the hoist (see Section 1.2) and they should be legible.	Replace.
Hoist Capacity Label	Visual	The label that indicates the capacity of the hoist should be legible and securely attached to the hoist.	Replace.

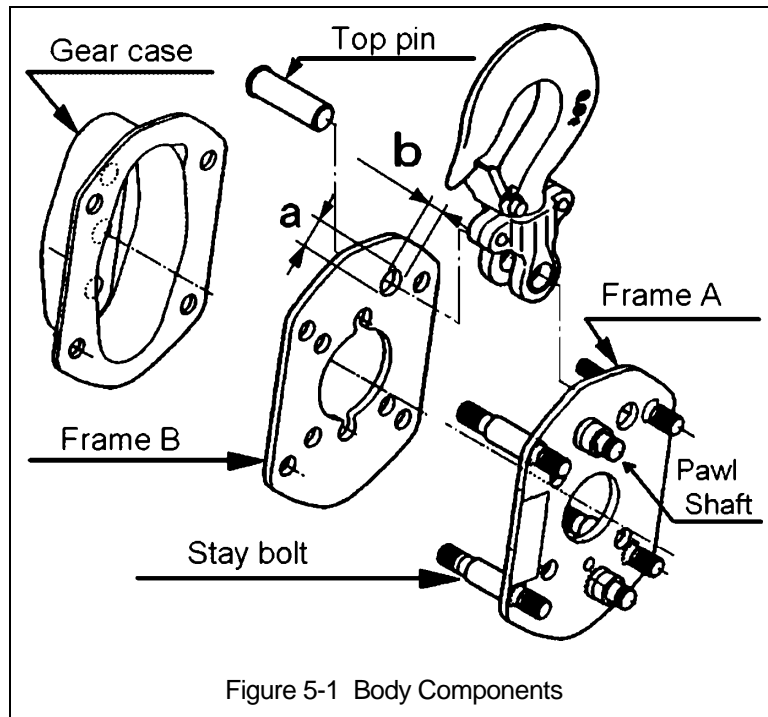

Figure 5-1 Body Components

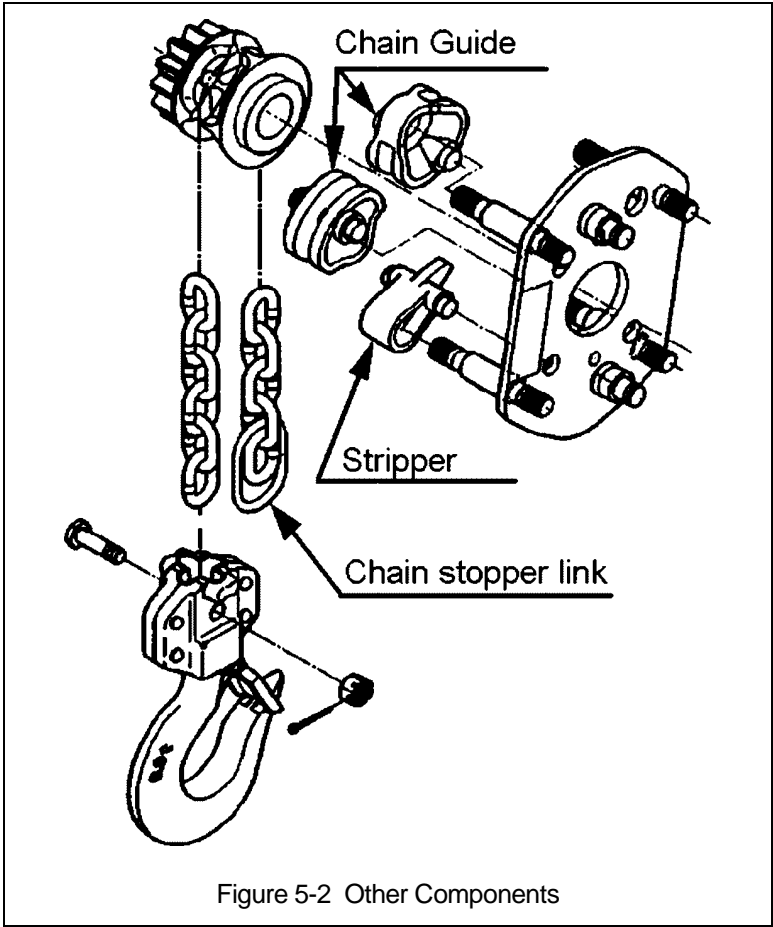

Figure 5-2 Other Components

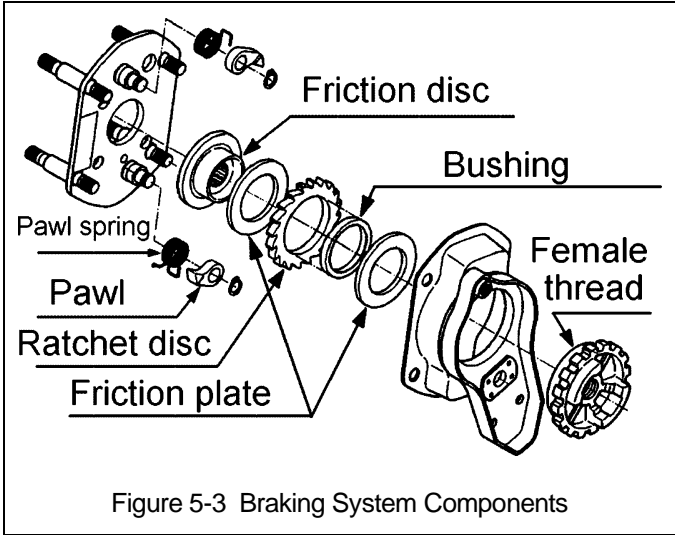

Figure 5-3 Braking System Components

Table 5-5 Friction Plate Wear Dimensions		
		
Product Code	Thickness inch (mm)	
	Standard	Discard
All	0.14 (3.5)	0.12 (3.0)

Table 5-6 Brake Bushing Wear Dimensions		
		
Product Code	A Dimension inch (mm)	
	Standard	Discard
All	0.16 (4.0)	0.12 (3.0)

Table 5-7 Brake Ratchet Disc Wear Dimensions		
		
Product Code	D Dimension inch (mm)	
	Standard	Discard
LB008, LB010, LB015, LB020, LB028	2.52 (64)	2.40 (61)
LB030, LB060, LB090	2.91 (74)	2.79 (71)

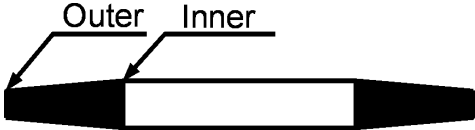

Product Code	L Dimension inch (mm)
	Standard
LB008, LB010, LB015, LB020, LB028	1.46 (37)
LB030, LB060, LB090	1.65 (42)

Table 5-9 Lifting Brake Spring Dimensions					
					
	Product Code	L Dimension Inches (mm)		A Dimension (degrees)	
		Standard	Discard	Standard	Discard
Non Slip Clutch	LB008, LB010, LB015, LB020, LB028	1.18 (30)		30°	45°
	LB030, LB060, LB090			25°	40°
With Slip Clutch	LB008, LB010, LB015, LB020, LB028	1.18 (30)		30°	45°
	LB030, LB060, LB090			0.98 (25)	25°

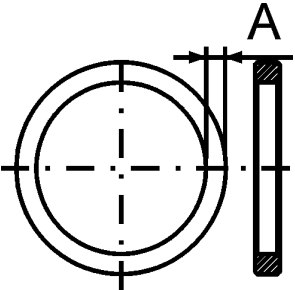
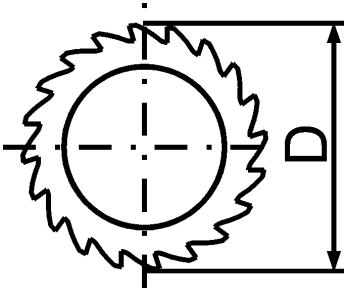
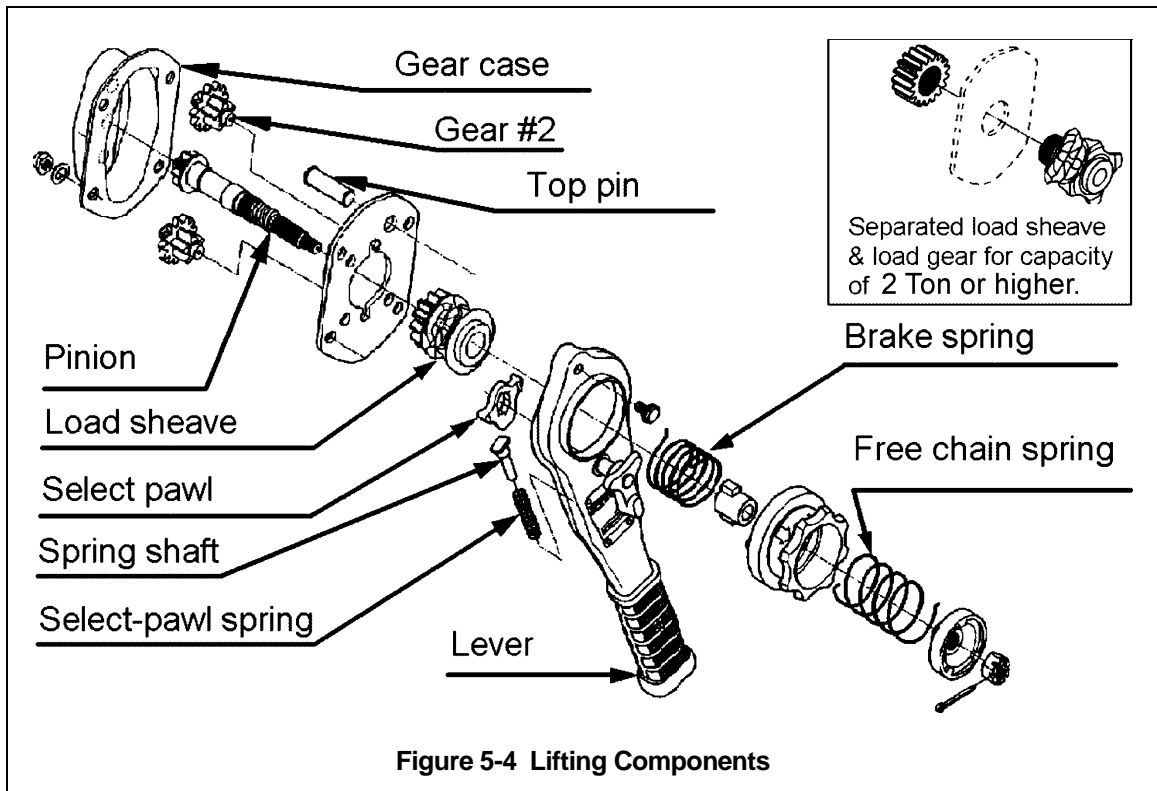
Table 5-10 Free Chain Spring Dimensions					
					
	Product Code	L Dimension Inches (mm)		A Dimension (degrees)	
		Standard	Discard	Standard	Discard
Non Slip Clutch	LB008, LB010, LB015, LB020, LB028	2.60 (66)	2.32 (59)	180°	165°
	LB030, LB060, LB090	2.80 (71)	2.52 (64)		
With Slip Clutch	LB008, LB010, LB015, LB020, LB028	2.64 (67)	2.36 (60)	145°	160°
	LB030, LB060, LB090	2.95 (75)	2.68 (68)	110°	125°

Table 5-11 Top Hook & Bottom Hook Dimensions

"k" Measured When New:

Top: _____

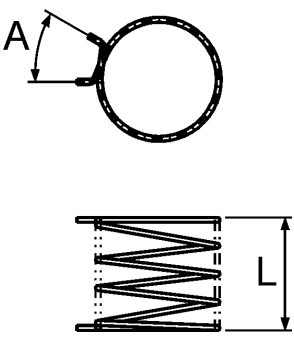
Bottom: _____

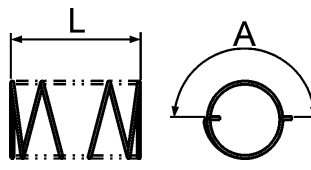
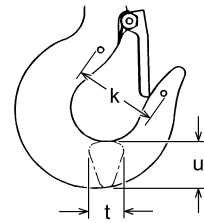

Product Code	Nominal "k" Dimension* inch (mm)	"u" Dimension inch (mm)		"t" Dimension inch (mm)	
		Standard	Discard	Standard	Discard
LB008	1.73 (44)	0.77 (19.6)	0.73 (18.6)	0.55 (14.0)	0.52 (13.3)
LB010	2.05 (52)	0.83 (21.0)	0.79 (20.0)	0.59 (15.0)	0.56 (14.3)
LB015	2.17 (55)	1.01 (25.7)	0.96 (24.4)	0.75 (19.0)	0.71 (18.1)
LB015-SYH	2.17 (55)	1.06 (27)	1.01 (25.7)	0.91 (23)	.86 (21.9)
LB020	2.48 (63)	1.14 (29.0)	1.09 (27.6)	0.83 (21.0)	0.79 (20.0)
LB028	2.48 (63)	1.14 (29.0)	1.09 (27.6)	0.83 (21.0)	0.79 (20.0)
LB028-SYH	2.52 (64)	1.26 (32)	1.13 (30.4)	0.98 (25)	0.94 (23.8)
LB030	2.64 (67)	1.22 (31.0)	1.16 (29.5)	0.96 (24.5)	0.92 (23.3)
LB030-SYH	2.72 (69)	1.42 (36)	1.35 (34.2)	1.10 (28)	1.05 (26.6)
LB060	3.54 (90)	1.61 (41.0)	1.54 (39.0)	1.34 (34.0)	1.27 (32.3)
LB090	4.37 (111)	2.05 (52.0)	1.95 (49.4)	1.63 (41.5)	1.55 (39.4)

* These values are nominal since the dimension is not controlled to a tolerance. The "k" dimension should be measured when the hook is new - this becomes a reference measurement. Subsequent measurements are compared to this reference to make determinations about hook deformation/stretch. See Section 5.8, "Hooks - Stretch".

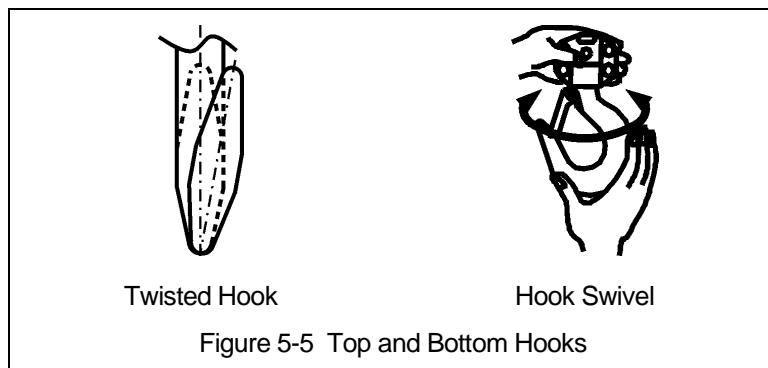



Table 5-12 Body Top Pin Wear Dimensions		
		
Product Code	d Dimension inch (mm)	
	Standard	Discard
LB008, LB010 LB015	0.47 (12)	0.45 (11.4)
LB020, LB028	0.55 (14)	0.52 (13.3)
LB030, LB060, LB090	0.63 (16)	0.60 (15.2)

Table 5-13 Chain Pin Hole and Top Pin Hole Wear Dimensions				
				
Product Code	Hole Diameter (d)			
	Chain Pin Hole inch (mm)		Top Pin inch (mm)	
	Standard	Discard	Standard	Discard
LB008, LB010	0.28 (7.1)	0.30 (7.6)	0.48 (12.2)	0.50 (12.7)
LB015	0.35 (8.9)	0.37 (9.4)	0.48 (12.2)	0.50 (12.7)
LB020, LB028	0.43 (11.0)	0.45 (11.5)	0.56 (14.2)	0.58 (14.7)
LB030	0.48 (12.3)	0.50 (12.8)	0.64 (16.2)	0.66 (16.7)
LB060, LB090	0.48 (12.3)	0.50 (12.8)	0.65 (16.4)	0.67 (16.9)

Table 5-14 Chain Wear Dimensions				
Product Code	"P" Dimension inch (mm)		"d" Dimension inch (mm)	
	Standard	Discard	Standard	Discard
LB008, LB010	3.11 (79.0)	3.20 (81.3)	0.22 (5.6)	0.20 (5.1)
LB015	3.94 (100.0)	4.05 (102.9)	0.28 (7.1)	0.25 (6.4)
LB020, LB028	4.88 (124.0)	5.02 (127.6)	0.35 (8.8)	0.31 (7.9)
LB030, LB060, LB090	5.55 (141.0)	5.71 (145.1)	0.39 (10.0)	0.35 (9.0)

Table 5-15 Chain Pin Wear Dimensions		
Product Code	"d" Dimension inch (mm)	
	Standard	Discard
LB008, LB010	0.27 (6.8)	0.26 (6.5)
LB015	0.34 (8.7)	0.33 (8.3)
LB020, LB028	0.43 (10.8)	0.41 (10.3)
LB030, LB060, LB090	0.48 (12.1)	0.45 (11.5)

6.0 Maintenance and Handling

6.1 Lubrication

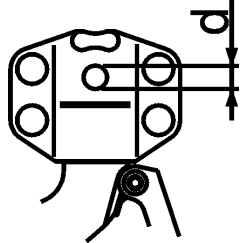
6.1.1 Load Chain

- **CAUTION** Model L4 and Model L5 chain is not interchangeable.
- For longer life, the load chain should be lubricated.
- The load chain lubrication should be accomplished after cleaning the load chain with an acid free cleaning solution.
- Apply Harrington lubricating grease (Part No. ER2CS1951) or an equivalent to industrial general lithium grease, NLGI No. 0, to the bearing surfaces of the load chain links as indicated by the shaded areas in Figure 6-1. Also apply the grease to the areas of the load chain (shaded areas in Figure 6-1) that contact the load sheave. Insure that the grease is applied to the contact areas in the load sheave pockets.
- Machine or gear oil (grade ISO VG 46 or 68 oil or equivalent) may be used as an alternative lubricant but must be applied more frequently.

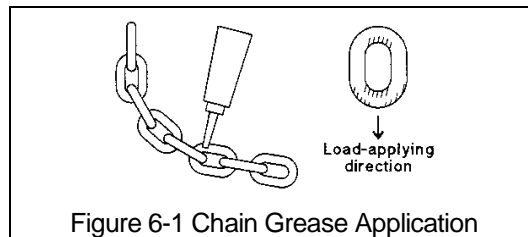

- The chain should be lubricated every 3 months (more frequently for heavier usage or severe conditions).
- For dusty environments, it is acceptable to substitute a dry lubricant.

6.1.2 Hooks and Suspension Components:

- Hooks – Bearings should be cleaned and lubricated at least once per year for normal usage. Clean and lubricate more frequently for heavier usage or severe conditions.
- Hook Yokes and Latches – Lubricate the hook yokes and hook latches at least twice per year for normal usage; more frequently for heavier usage or severe conditions.
- Suspension Pins - Lubricate the chain pin and the top pin at least twice per year for normal usage; more frequently for heavier usage or severe conditions.

6.2 Disassembly, Assembly and Adjustment

6.2.1 **NOTICE**

- 1) Perform proper disassembly or assembly in accordance with this manual.
- 2) The hoist utilizes dry friction plates; they are not to be lubricated.
- 3) Do not extend the load chain.
- 4) Remove old grease on the disassembled parts.
- 5) Replace components with Harrington Hoist approved parts.
- 6) To reassemble, apply new grease, and use a new split pin and snap ring.

Note: The following symbols in this manual indicate the recommended lubricants.

G1: NLGI No. 2

G2: Turbine Oil

G3: NLGI No. 1

6.2.2 Tools – The following tools are required to disassemble/reassemble the hoist.

Table 6-1 Tools Required for Hoist Disassembly		
No.	Tool	Operation
1	Snap ring pliers	Opening a snap ring
2	Socket wrenches: 12, 14 mm	Slotted nuts
3	Hex keys: 4, 5, 10, 12 mm	Socket head cap screws
4	Wrenches: 10, 12, 13, 14, 17 mm	Bolts and nuts
5	Phillips screwdriver	Machine screws
6	Pliers	Split pins
7	Soft-face (plastic) hammer	

6.3 Hoist Disassembly

Proceed as follows:

6.3.1 Free Chain Knob

- 1) Pull out (50) Split Pin and remove (49) Slotted Nut.
- 2) Remove (48) Spring Holder, (47) Free Chain Spring, (45) Free Chain Knob assembly, (43) Brake Spring and (44) Cam Guide from (16) Pinion.

6.3.2 Lever

- 1) Remove (31) Acorn nuts and (32) Spring Lock Washers, which attaches (29) Brake Cover assembly to (10) Frame A assembly.
- 2) While holding (37) Lever assembly horizontally by hand, turn (33) Female Thread counterclockwise and remove the lever assembly (29) Brake Cover assembly from the hoist.
- 3) Remove (42) Hex Cap Screw and (30) Flange Nut, and separate (37) Lever assembly and (29) Brake cover assembly.
- 4) Remove (33) Female Thread from (29) Brake cover assembly.
- 5) Remove (34) Select Pawl, (35) Spring Shaft and (36) Selector-Pawl Spring from (37) Lever assembly.

6.3.3 Brake

- 1) Remove the parts from (16) Pinion in the following order, (26) Friction Plate (one piece), (27) Ratchet Disc, (28) Bushing, (26) Friction Plate (1 piece) and (25) Friction Disc.
- 2) Remove (24) Snap Ring from the pawl shaft with snap ring pliers, and remove (22) Pawl and (23) Pawl spring.

6.3.4 Gears

- 1) Remove (14) Acorn Nut and (15) Spring Lock Washer, and detach (13) Gear Case assembly.

- 2) Remove (17) Gear #2 and (16) Pinion. On LB028 to LB090 hoists remove (18) Load Gear.
- 3) Pull out (3) Top Pin and remove (1) Top Hook set.

6.3.5 Load Chain

- 1) Remove (12) Frame B, (20) Chain Guide and (21) Stripper.
- 2) Remove (52) Load chain and (19) Load Sheave.
- 3) For LB008 to LB030 hoists remove (9) Split Pin, (8) Slotted Nut and (7) Chain Pin from (4) Bottom Hook Set, and remove (52) Load chain.
- 4) For LB060 and LB090 hoists remove (23) Split Pin, (22) Slotted Nut and (21) Chain Pin from (10) Bottom or (1) Top Hook Set. Remove (15) Lever Nuts and (14) Bolts form (13) Bottom or (4) Top Yoke Assembly then remove (7) and (15) Idle Sheeve(s).

6.4 Hoist Assembly

6.4.1 **⚠️ WARNING**

- Inspect and replace any worn or damaged parts per Table 5-3.
- Secure all nuts, bolts and split pins firmly.
- Replace all split pins and retaining rings.

6.4.2 Lever

Refer to Figure 6-1, proceed as follows:

- 1) Set the Selector Lever on the (37) lever assembly to the 'N' position.
- 2) With the Selector Lever pulled in the 'a' direction, as shown in the left picture, insert the hex part of the Selector Lever into (34) Select pawl.
- 3) Apply (G1) grease lightly to the pawl of (34) Select Pawl and to the top of (35) Spring Shaft as shown in Figure 6-1.
- 4) Insert (35) Spring Shaft into (36) Select-Pawl spring and attach them into the Spring Holder.

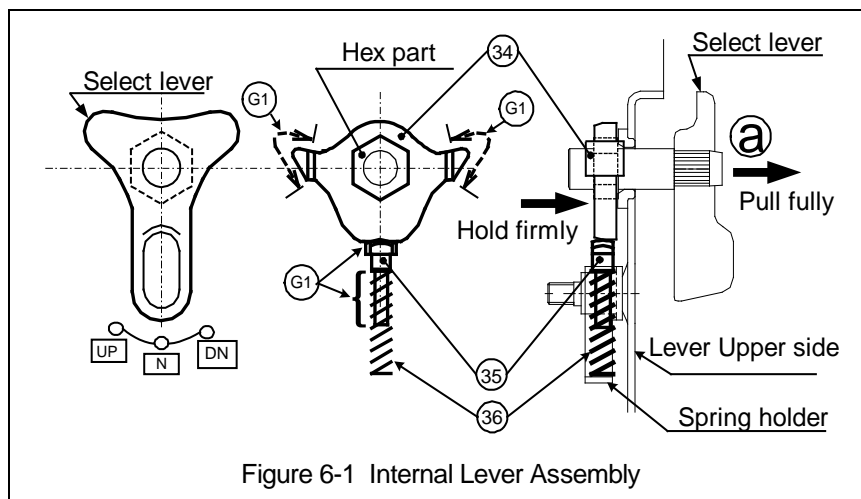

Refer to Figure 6-2, proceed as follows.

- 1) **⚠️ WARNING** Do not apply oil to the friction side of the Female Thread.

- 2) **⚠ CAUTION** Clean the friction side of the Female Thread.
- 3) Apply (G3) grease lightly to the thread of (33) Female Thread.
- 4) Place (33) Female Thread, friction side first into the (29) Brake Cover assembly.
- 5) Install (37) Lever assembly onto (29) Brake Cover Assembly and secure with (42) Hex Cap Screw and (30) Flange Nuts.

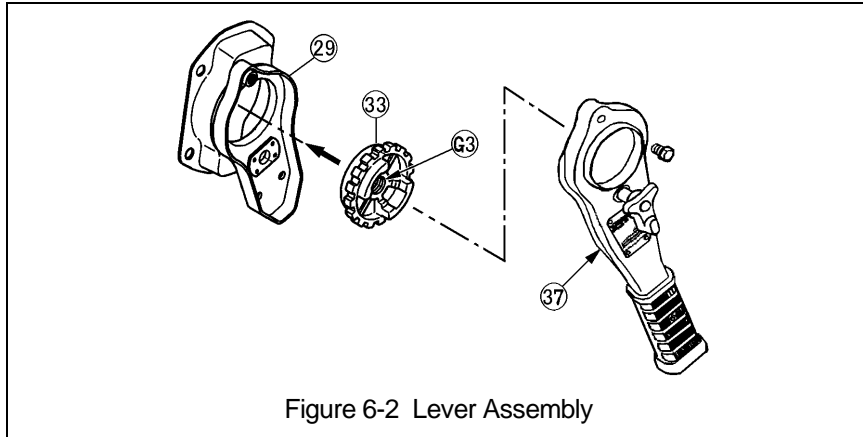

6.4.3 Lever Grip

- 1) **⚠ CAUTION** Read ALL instructions below BEFORE applying glue.
- 2) Remove dirt, water, oil and rust from the area of the Lever where the glue will be applied for the new grip. Note: Glue is included with the replacement Lever Grip.
- 3) Make a quick and even application of the glue on the four sides of the Lever as shown in Figure 6-3. (38) Grip must be installed within 10 seconds after applying the glue to the Lever.

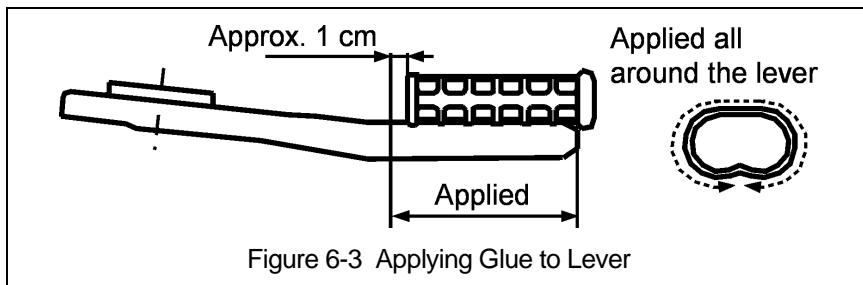

- 4) Refer to Figure 6-4 and place (38) Grip on Lever with its inside boss aligned with the boss hole in the Lever. Make sure boss of (38) Grip is completely seated into the boss hole of the lever.
- 5) Firmly install (39) Binding Screw through the Grip and Lever Assembly.

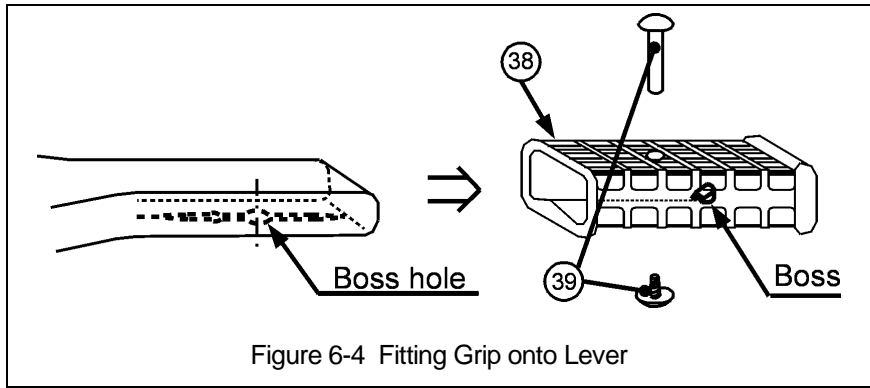

6.4.4 Load Sheave and Chain Assembly

- 1) For LB008 to LB030 hoists attach (4) Bottom Hook set to (52) Load chain with (8) Slotted Nut and (7) Split Pin.
- 2) For LB060 and LB090 hoists apply (G1) grease the bearing surface of the (17) Shaft Assembly and (16) (17) Idle Sheave. Install the shaft and sheave into the (13) Bottom or (4) Top Yoke assembly and secure the yokes with (14) bolts and (15) Lever Nuts.
- 3) Apply (G3) grease to the inner parts of the bearing hole of (10) Frame A Assembly and (19) Load Sheave as shown in Figure 6-5.
- 4) Attach (19) Load Sheave to (10) Frame A Assembly on Stay Bolt side with the gear or spline oriented as shown in Figure 6-5.

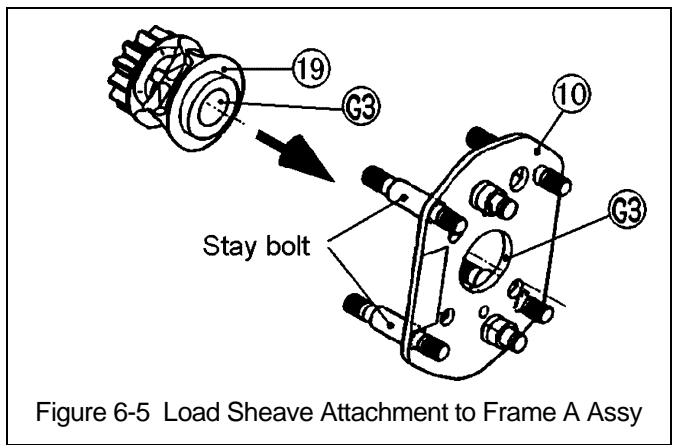

- 5) Place the (52) Load chain on (19) Load Sheave and install (20) Chain Guides and (21) Stripper. Refer to Figure 6-6.
- 6) **CAUTION** Orient the load chain with the (53) Chain stopper link parallel to the frame and welds to the outside of the Load Sheave.

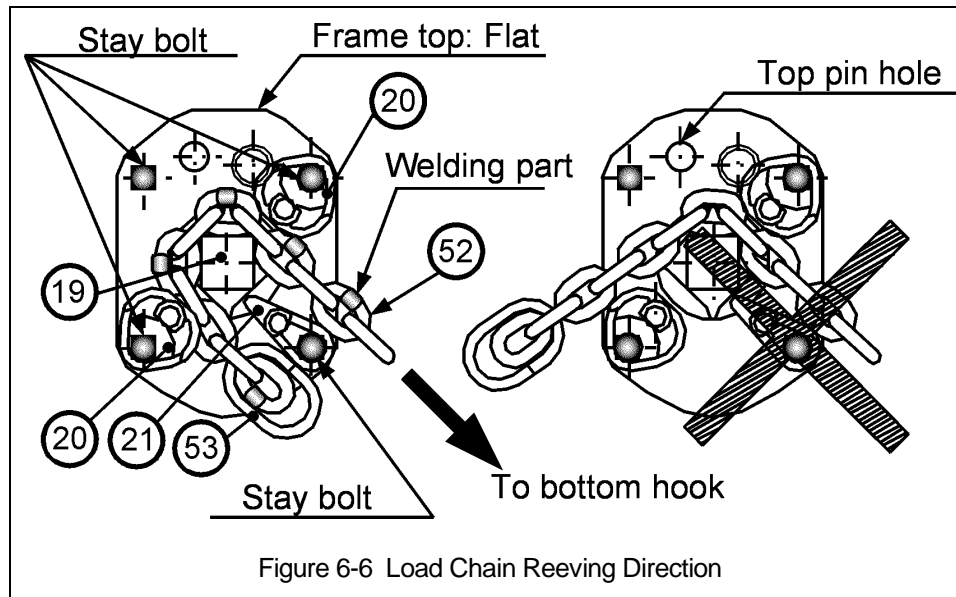

- 7) Apply (G3) grease to the bearing part of (12) Frame B. Refer to Figure 6-7.
- 8) Install (12) Frame B onto (10) Frame A Stay Bolts. Make sure to align the top flat parts of the both frames.

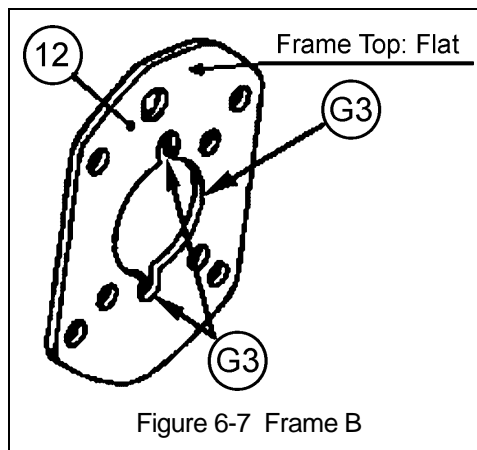

6.4.5 Top Hook

- Install the (1) Top hook set between (10) Frame A assembly and (12) Frame B then Insert (3) Top pin from the side of (12) Frame B to fasten (1) Top hook set. Refer to Figure 6-8.

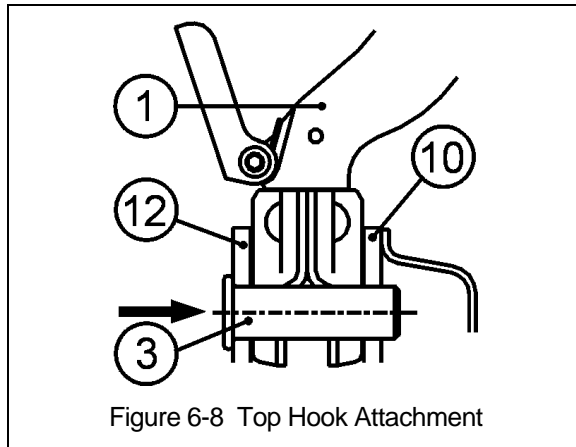

Figure 6-8 Top Hook Attachment

6.4.6 Gears

- 1) For LB020 to LB090 hoists, attach (18) Load Gear to the serrated part of (19) Load Sheave. If necessary use a plastic or rubber hammer to make the load gear is fully seated on the Load Sheave.
- 2) Insert (16) Pinion into (19) Load Sheave and install (17) Gear #2 as shown in Figure 6-9. Gear #2 must be timed with the "0" marks as shown for the gears to rotate freely.

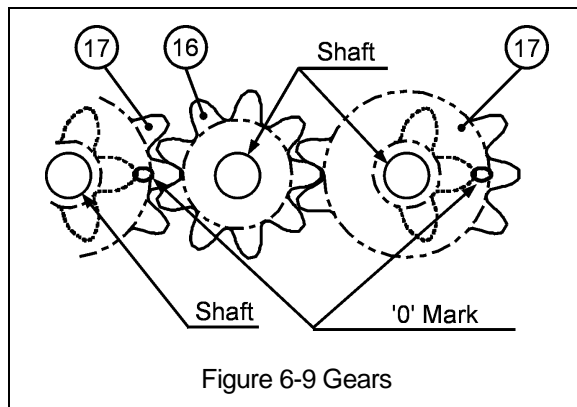

Figure 6-9 Gears

- 3) Apply (G1) grease to (16) Pinion, (17) Gear #2 and (18) Load Gear. Refer to Table 6-2 for the correct amount of grease.

Table 6-2 Amount of Grease to Apply to the Gears by Hoist Code	
Hoist Code	Grease (Approximate) (Grams)
LB008, LB010	20
LB015, LB028	30
LB030, LB060, LB090	60

- 4) Install (13) Gear Case assembly over the gears and fix it firmly to the Stay Bolts with (14) Acorn Nut and (15) Spring Lock Washer. Make sure the top flat part of the gear case aligns with the flat on (12) Frame B.

6.4.7 Brake

- 1) Lightly apply (G2) grease to the Pawl Shaft and (22) Pawl. Refer to Figure 6-10.
- 2) **CAUTION** Use a minimal amount of grease on (22) Pawl to avoid getting grease on the friction surfaces of the brake.
- 3) Fasten two sets of (23) Pawl Spring and (22) Pawl with (24) Snap Ring.

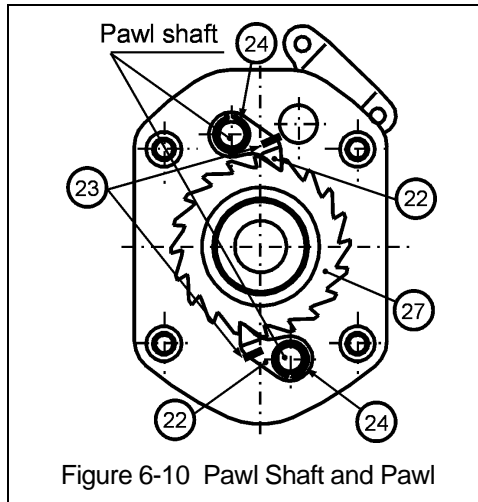

- 4) While holding two (22) pawls outward, install (25) Friction Disc, (26) Friction Plate, (28) Bushing, (27) Ratchet Disc and (26) Friction Plate properly in this order. Refer to Figure 6-11.

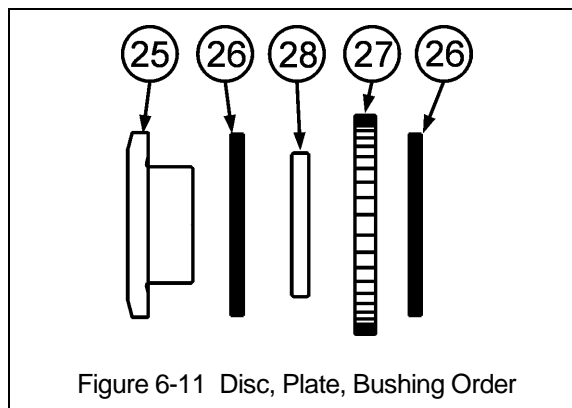

- 5) **CAUTION** Make sure that the Pawl Spring fits into the pawl.
- 6) **CAUTION** Make sure that the pawl comes into good contact with the Ratchet Disc.
- 7) **CAUTION** The Friction Plates are dry (not lubricated). Do not apply oil to them.
- 8) **CAUTION** Ensure sure that (28) Bushing is sufficiently oiled. If it is not, soak the Bushing in turbine oil for a day and wipe off excess.

6.4.8 Hoist Lever and Body

- 1) Attach the Lever assembled in Section 6.4.2 to the previously assembled Brake. Fit (29) Brake Cover assembly and (10) Frame A assembly by screwing (33) Female Thread of the Lever assembly clockwise to the thread of (16) Pinion until it makes a clicking sound. Make sure the flat part of the Brake Cover aligns with the flat on Frame A.
- 2) Fasten (29) Brake Cover assembly firmly to the Stay Bolts with (14) Acorn Nuts and (15) Spring Lock Washer.
- 3) **⚠ CAUTION** To eliminate a clearance in the Brake section, perform the following procedures before moving onto the next step.
 - A) Set the Selector Lever to 'N' position.
 - B) Turn (33) Female Thread clockwise to tighten the Brake lightly with (52) Load chain at the hook side held by hand firmly without (19) Load Sheave's rotation.
 - C) The hoist will make "clicking" sounds if the chain is not being held sufficiently. The clearance will be reduced while the hoist is "clicking". After tightening, make sure that the Female Thread will not rotate counterclockwise on the (16) Pinion.
- 4) To attach (44) Cam Guide to (16) Pinion, aligning the boss of the Guide slightly to the right of the middle of (33) Female Thread's boss as shown in Figure 6-12.
- 5) Apply (G3) grease lightly to the side of (44) Cam Guide.

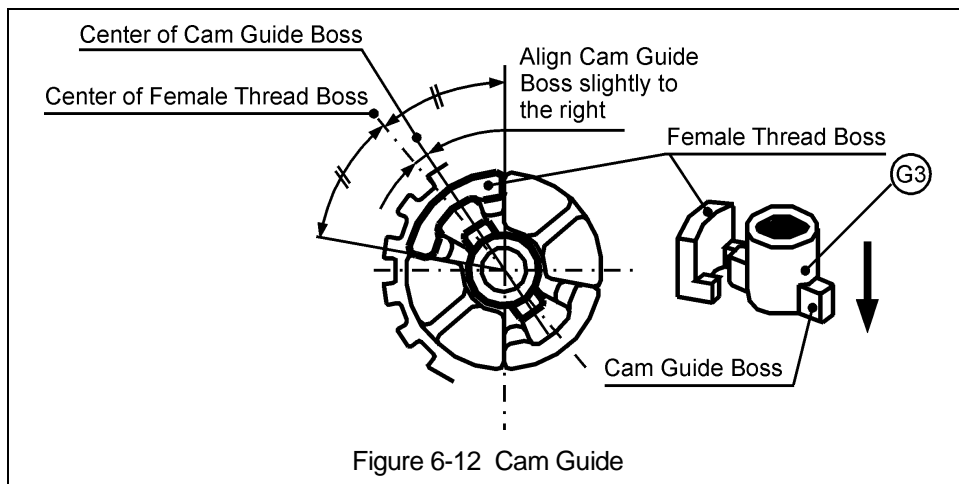

6.4.9 Free Chain Knob

- 1) Set (43) Brake Spring (silver color) into the slot of the back of (45) Free Chain Knob assembly. Refer to Figure 6-13. As indicated in Figure 6-13, set the end of the spring next to the rib of the knob.

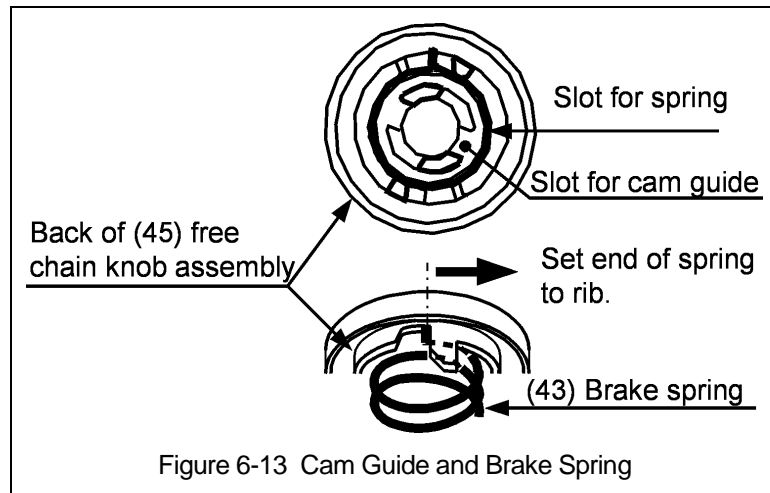

- 2) Fit the opposite end of (43) Brake Spring next to the boss of the Female Thread. Refer to Figure 6-14.

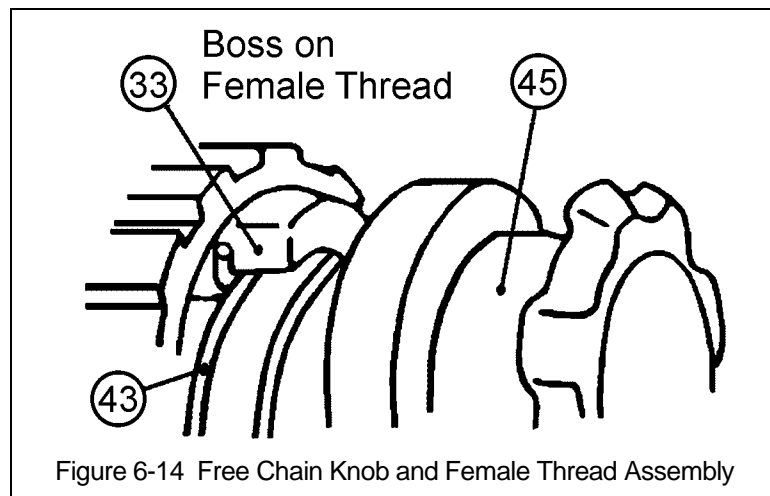

- 3) While holding the load chain on the hook side firmly to prevent (19) Load Sheave from rotating, turn (45) Free Chain Knob assembly 120° clockwise while pressing it lightly on (33) Female Thread. Refer to Figure 6-15. As the Free Chain Knob turns, the cam parts of (44) Cam Guide fit into the slots of the Free Chain Knob.
- 4) Rotate the Selector Lever to the Up or Down position to temporarily retain the (45) Free Knob.

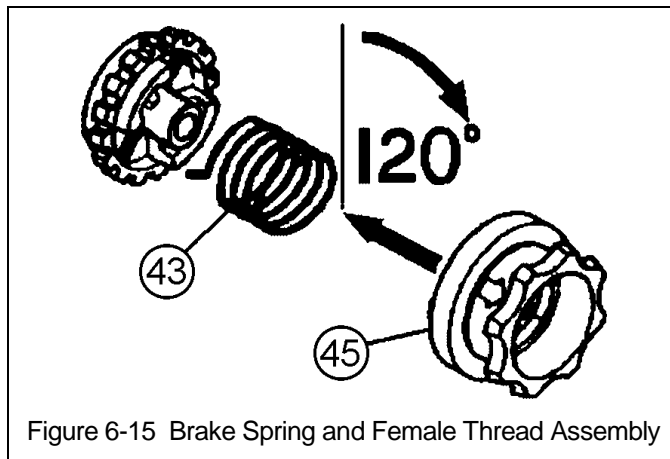

- 5) Hook the outward-projecting end of (47) Free Chain Spring onto the slot at the back of (48) Spring Holder, and hook the other end (inward-projecting) of the Spring onto the slot of (45) Free Chain Knob assembly. Refer to Figure 6-16.

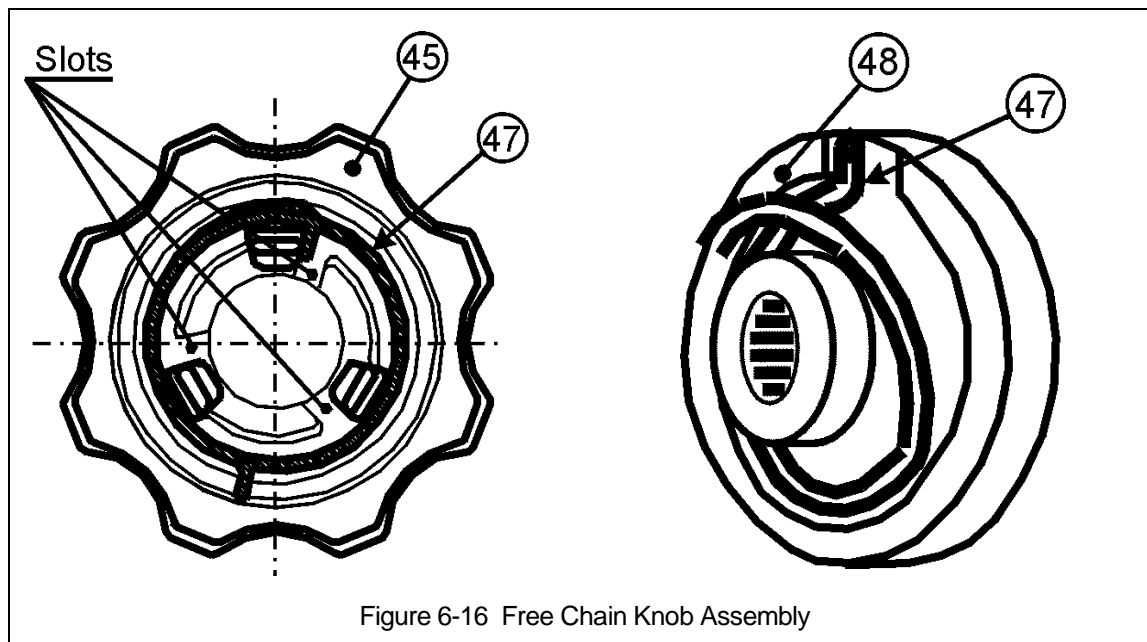

- 6) Turn (48) Spring Holder 120° **counterclockwise** while lightly pressing it toward the (45) Free Chain Knob assembly. Install the spring holder onto the Pinion serration and hold it in place. Refer to Figure 6-17.
- 7) While holding the (48) Spring Holder in place, fasten it in place with the (49) Slotted Nut and (50) Split pin.
- 8) Set the Selector Lever to the 'N' position and pull the Free Chain Knob into the free chaining mode. Operate the hoist in the free chain mode to ensure correct performance.
- 9) **⚠ CAUTION** If the free chaining can not be performed, the hoist has been assembled incorrectly. Correctly reassemble the hoist in accordance with this procedure.

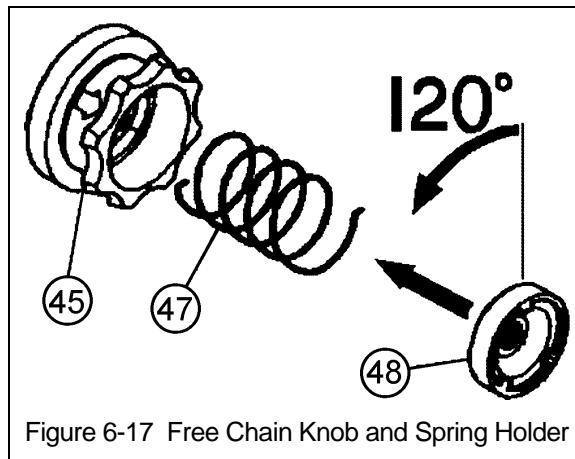

6.4.10 Preoperational Checks

- 1) Make sure all nuts, bolts and split pins are sufficiently fastened.
- 2) Make sure all components have been installed correctly.
- 3) **CAUTION** After assembly, perform the following preoperational checks before operating hoist.
- 4) Make sure that the hoist operates properly under no load condition before lifting a load.
- 5) Perform a load test at 125% of rated load in accordance with ASME B30.21.
- 6) Record of load test and maintenance performed should be placed on file with the inspection records referenced in section 5.6.1.
- 7) During lifting and lowering operations check the following.
 - There should be no irregular clicking or abnormal sounds when lifting.
 - Lever pull should not be difficult in lifting mode.
 - The hoist brake should not slip.

6.5 Chaining

- 6.5.1 Verify end links of chain are in the same plane. Refer to Figure 6-18.

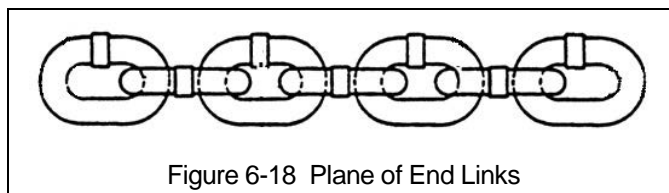

- 6.5.2 Place the hoist on its side with the top hook facing away from you and the lever on the right side.
- 6.5.3 Place the Selector Lever in the neutral position.
- 6.5.4 Insert a standing link into the load sheave with the weld facing away from the load sheave. Refer to Figure 6-19.
- 6.5.5 Rotate the free wheel knob clockwise to begin feeding the chain into the hoist.

- 6.5.6 Hang the hoist from a suitable fixture and continue to feed the chain until it exits through the bottom of the hoist. Make sure chain passes through, not over, both chain guides. Refer to Figure 6-20.

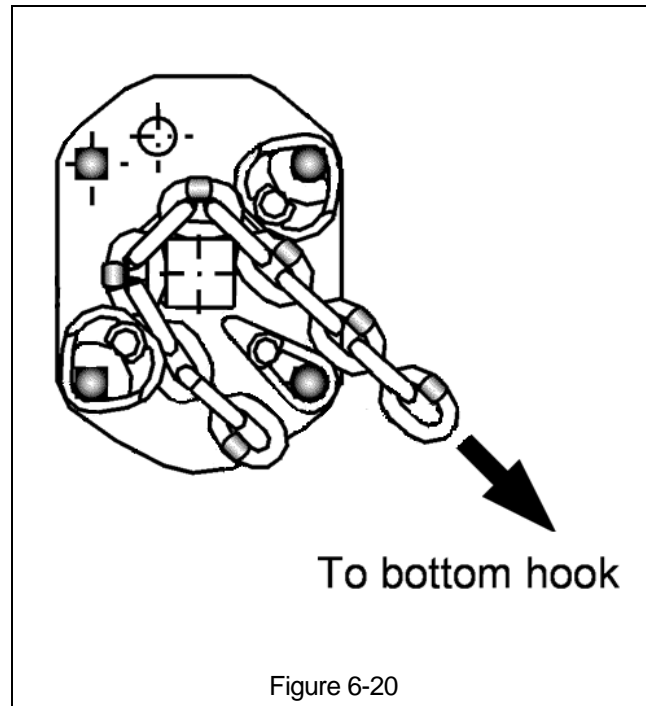
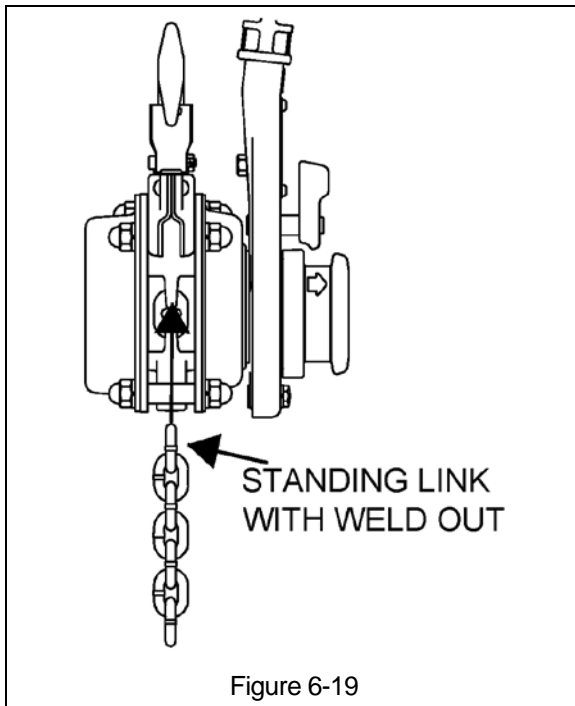

- 6.5.7 Pull chain out the bottom of the hoist until there is approx. 2 feet of chain on the load side of the hoist.
- 6.5.8 Attach a warning tag (WTAG9) to the chain stopper link, and attach the chain stopper link to the **NEXT TO LAST LINK** of chain on the no load side of the hoist.
- 6.5.9 For single fall hoists, insert load chain into the bottom hook, insert chain pin, attach castle nut, and insert split pin.
- 6.5.10 For 6T hoists, feed a piece of small diameter mechanics type wire through the bottom hook block around the idle sheave.
- 6.5.10.1 Make sure there are no twists in the load chain and attach the load chain to the wire in the bottom hook block.
 - 6.5.10.2 Feed the chain into the bottom hook block, making sure that the welds are facing the idle sheave. Refer to Figure 6-21.
 - 6.5.10.3 Remove wire from the chain and insert the end link of chain into the top hook block.
 - 6.5.10.4 Install chain pin, castle nut, and split pin.
- 6.5.11 For 9T hoists, feed a piece of small diameter mechanics type wire around the idle sheaves in the top and bottom hook blocks.
- 6.5.11.1 Make sure there are no twists in the load chain and attach the load chain to the wire in the bottom hook block.
 - 6.5.11.2 Feed the chain into the bottom hook block, making sure that the welds are facing the idle sheave. Refer to Figure 6-21.
 - 6.5.11.3 Attach the load chain to the wire in the top hook block and pull it around the idle sheave so that the end of the chain will exit the idle sheave towards the center of the bottom hook block. Refer to Figure 6-22.

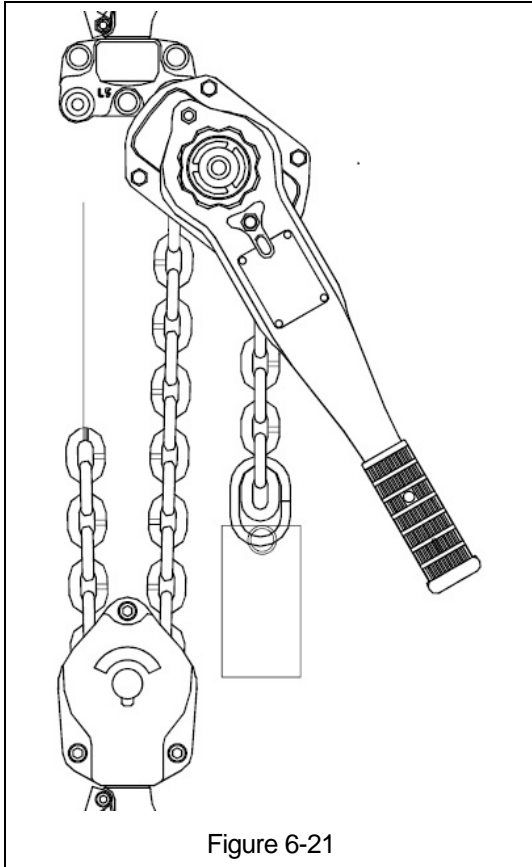

Figure 6-21

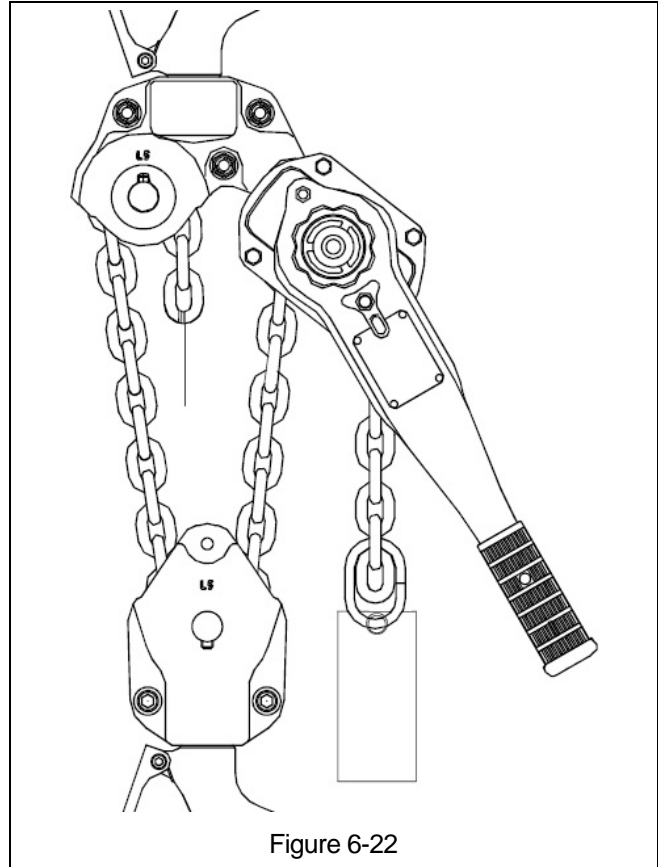

Figure 6-22

6.5.11.4 Install the chain pin, castle nut, and split pin.

6.6 Storage

6.6.1 The storage location should be clean and dry.

6.6.2 The hoist should be clean and dry. The load chain and all other exposed metal should be well lubricated.

6.7 Outdoor Installation

6.7.1 The hoist/trolley should be covered when not in use.

6.7.2 The hoist/trolley **MUST BE** inspected and maintained according to the 'Severe Service' Inspection Classification. **Refer to Section 5.0.**

6.7.3 Possibility of corrosion on components of the hoist increases for installations where salt air and high humidity are present. For installations where temperature variations introduce condensation/corrosion into the hoist, more frequent lubrication may be required.

6.7.4 Refer to **Section 2.1.2** for allowable environmental conditions.

7.0 Troubleshooting

⚠ WARNING

Read and comply with instructions in this manual and use the hoist properly.
 Checking the sounds from the hoist in operation is a critical inspection. Note hoist sounds during operation.
 If a defect is found in the hoist, stop using it immediately and check the cause of the defect.
 Only Trained and competent personnel should inspect and repair the hoist.

Table 7-1 Troubleshooting Guide

Note on proper operation:

- When lifting, the lever should make clicking sounds when moving the lever forward and backward.
- When lowering, the lever should make clicking sounds only when moving the lever backward (not forward).

Symptom	Cause	Remedy
Hoist will not lift – Slight clicking	Improper assembly of ratchet disc, disc installed backwards and making incorrect contact with the pawl. 	Reassemble the pawl and ratchet disc properly. Ensure that clicking sounds are heard before reuse. 
Hoist will not lift – Not Clicking	Pawl not engaging ratchet disc: <ul style="list-style-type: none"> ■ Dirt or corrosion between pawl and pawl shaft. 	Clean and lubricate pawl and pawl shaft. 
	Faulty pawl spring	Replace pawl spring
	Improper selector lever fit <ul style="list-style-type: none"> ■ Missing selector pawl spring ■ Assembled incorrectly (wrong direction) 	Reassemble properly and ensure selector lever clicks before reuse.
		Loose selector pawl spring

Table 7-1 Troubleshooting Guide

Symptom	Cause	Remedy
Hoist will not lift – Lever will not operate	Gear #2 improperly timed	Reassemble gears properly and ensure smooth operation before reuse. ⚠ CAUTION Ensure the '0' marks of gear #2 are aligned properly, as shown. 
Hoist with Slip Clutch Hoist will not lift – Lever will operate but load will not move.	Slip Clutch activated.	Reduce load to less than rated capacity.
Hoist with Slip Clutch Hoist will not lift under rated capacity.	Slip Clutch malfunction. Due to frequently operating hoist with greater than rated load.	Replace friction clutch. Do not frequently operate hoist with greater than rated load.
Hoist will lift intermittently – Slight or irregular clicking	Poor pawl movement caused by faulty pawl spring. The spring is loose or damaged.	Perform maintenance and/or repair.
	Mis-assembly of pawl spring	Reassemble it properly and ensure to check click sound of the pawl before reuse.
During operation, hoist idles or load drifts	Poor contact of load sheave and load chain caused by improper chain-reeving (see picture) 	Reassemble properly and ensure proper lifting before reuse. 
Hoist will not lift without load	Mis-assembly of brake spring Insufficient angle to set the spring will cause a poor braking. 	Reassemble properly. ⚠ CAUTION Turn the free chain knob 120° clockwise and set the brake spring. 

Table 7-1 Troubleshooting Guide

Symptom	Cause	Remedy
Hoist will not lift all the way (multiple fall hoists)	Capsized hook	Reset the capsized hook. 

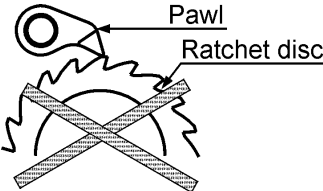
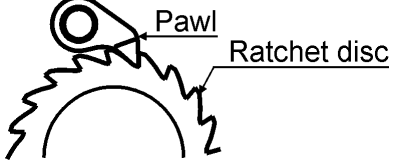
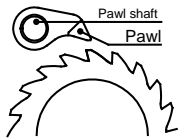
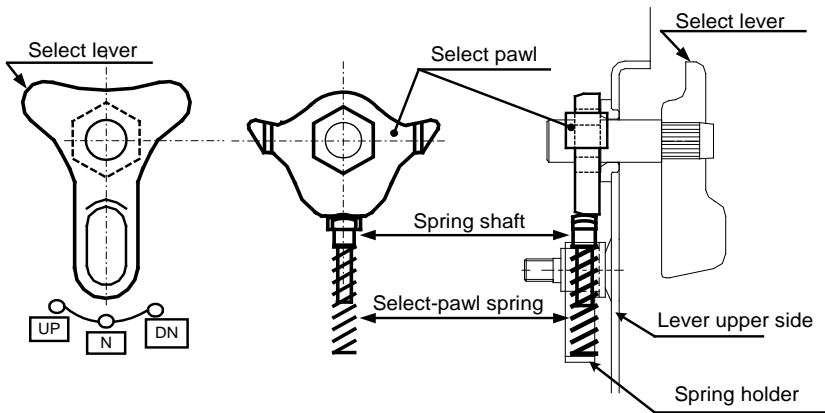
CAUTION Improper braking may cause improper load lowering. The hoist utilizes dry friction discs, do not apply oil to friction surfaces.

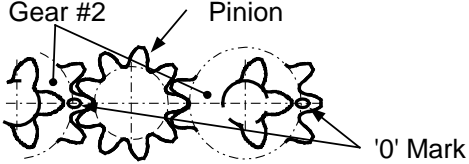
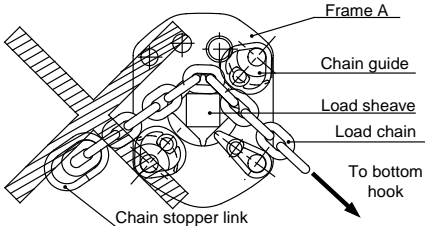
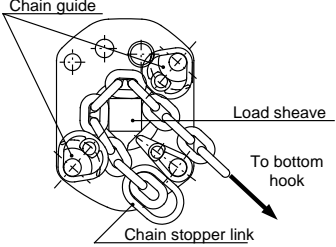
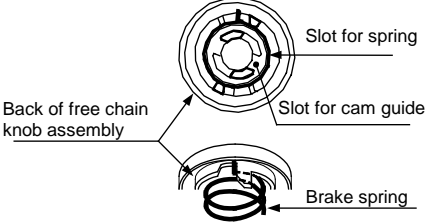
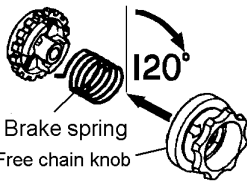
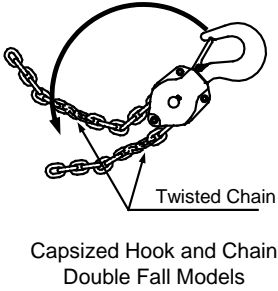
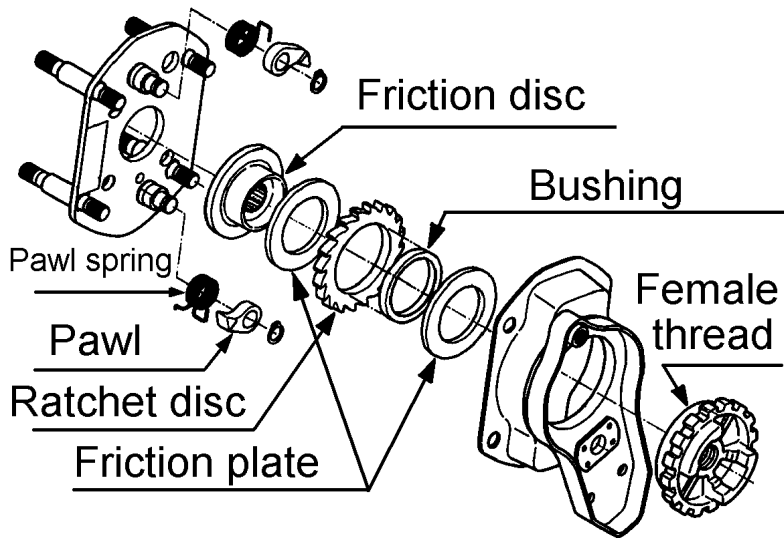

Symptom	Cause	Remedy
Load will not go down	Over tightened brake The hoist left under load for a long period Shock loaded during operation	Set the selector lever to 'DN' position and reset the brake by pulling harder on the lever.
	Brake rusted tight	Replace the rusty components and perform hoist maintenance.
Load drifts or slips when lowering	A foreign object between friction surfaces.	Remove the object and clean the surfaces. Replace if the friction surface is scarred.
	Brake slip caused by significant rust	Replace the rusty component and perform hoist maintenance.

Table 7-1 Troubleshooting Guide

Symptom	Cause	Remedy
	<p>Mis-assembly of friction plates, i.e. friction plates missing or at one side as shown.</p> 	<p>Reassemble properly as shown and ensure hoist functions properly before reuse.</p> 
	<p>Cracked friction plate caused by overload</p>	<p>Replace the friction plate and use the hoist properly within rated capacity.</p>
	<p>Friction plate wear caused by very frequent and long term use.</p>	<p>Perform hoist maintenance.</p>
<p>Load drifts or slips when lowering, continued</p>	<p>Mis-assembly of female thread and cam guide</p>	<p>Reassemble Female Thread and Cam Guide properly.</p>
	<p>Attaching cam guide without tightening female thread may cause an un-tightened brake.</p>	<p>CAUTION Secure the female thread firmly before attaching cam guide.</p>
		
<p>Free chain knob does not move in and out</p>	<p>Damaged or deformed friction plate</p>	<p>Perform hoist maintenance.</p>
<p>Hoist will not free wheel</p>	<p>Load chain pulled to hard and brake engaged</p>	<p>Pull the load chain with less force</p>
	<p>Mis-assembly of free chain spring Chain Spring twisted at excessive angle</p>	<p>See the symptom of “Hoist will not lift without load.”</p>
<p>Load drifts or slips when selector lever is set in free chain mode</p>	<p>Mis-assembly of free chain spring Poorly tightened brake caused by insufficient twist angle.</p>	<p>See the symptom of “Hoist will not lift without load.”</p>

Table 7-1 Troubleshooting Guide

Symptom	Cause	Remedy
Hard to reset the hoist out of free chain mode	Mis-assembly of free chain spring Insufficient twist angle	Reassemble properly. 

8.0 Warranty

All products sold by Harrington Hoists, Inc. are warranted to be free from defects in material and workmanship from date of shipment by Harrington for the following periods:

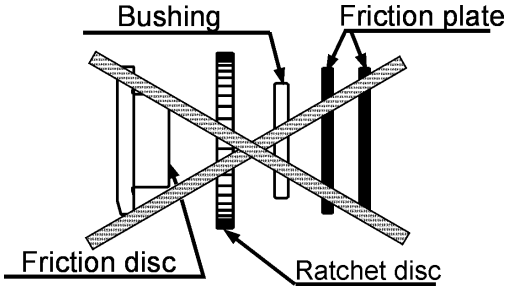
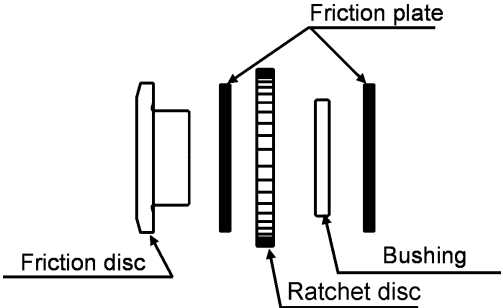
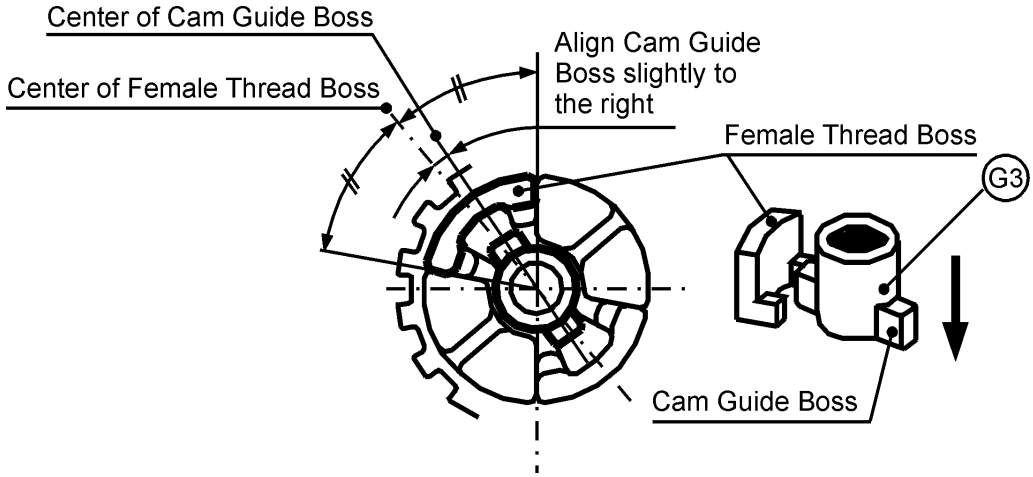
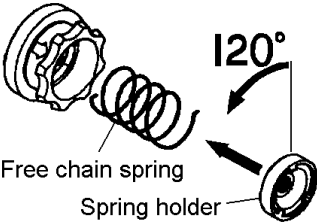
- 1 year – Electric and Air Powered Hoists (excluding (N)ER2 Enhanced Features Models and EQ/SEQ Models), Powered Trolleys, Powered Tiger Track Jibs and Gantries, Crane Components, Below the Hook Devices, Spare / Replacement Parts**
- 2 years – Manual Hoists & Trolleys, Beam Clamps**
- 3 years – (N)ER2 Enhanced Features Hoists, EQ/SEQ Hoists, and RY Hoists**
- 5 years – Manual Tiger Track Jibs and Gantries, TNER, EQ/SEQ, and RY Hoist Motor Brakes**
- 10 years – (N)ER2 “The Guardian” Smart Brake**

The product must be used in accordance with manufacturer’s recommendations and must not have been subject to abuse, lack of maintenance, misuse, negligence, or unauthorized repairs or alterations.

Should any defect in material or workmanship occur during the above time period in any product, as determined by Harrington Hoist’s inspection of the product, Harrington Hoists, Inc. agrees, at its discretion, either to replace (not including installation) or repair the part or product free of charge and deliver said item F.O.B. Harrington Hoists, Inc. place of business to customer.

Customer must obtain a Return Goods Authorization as directed by Harrington or Harrington’s published repair center prior to shipping product for warranty evaluation. An explanation of the complaint must accompany the product. Product must be returned freight prepaid. Upon repair, the product will be covered for the remainder of the original warranty period. Replacement parts installed after the original warranty period will only be eligible for replacement (not including installation) for a period of one year from the installation date. If it is determined there is no defect, or that the defect resulted from causes not within the scope of Harrington’s warranty, the customer will be responsible for the costs of returning the product.

Harrington Hoists, Inc. disclaims any and all other warranties of any kind expressed or implied as to the product’s merchantability or fitness for a particular application. Harrington will not be liable for death, injuries to persons or property or for incidental, contingent, special or consequential damages, loss or expense arising in connection with the use or inability whatever, regardless of whether damage, loss or expense results from any act or failure to act by Harrington, whether negligent or willful, or from any other reason.

This Page Intentionally Left Blank

9.0 Parts List

When ordering Parts, please provide the Hoist code number, lot number and serial number located on the Hoist nameplate (see Figure 9-1 and Figure 9-2 below).

Reminder: Per Sections 1.1 and 3.4.4 to aid in ordering parts and product support, record the hoist Code, Lot and Serial Number in the space provided on the cover of this manual.

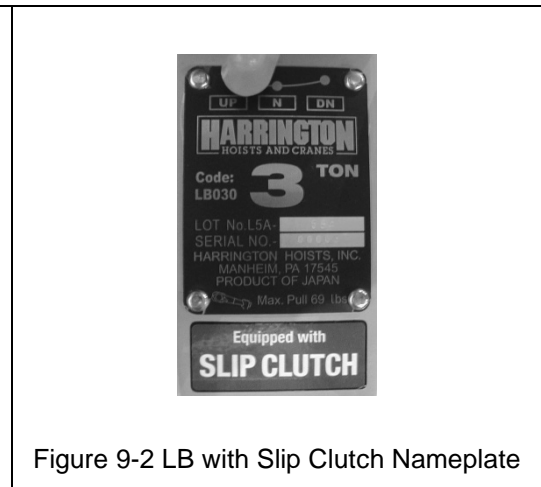
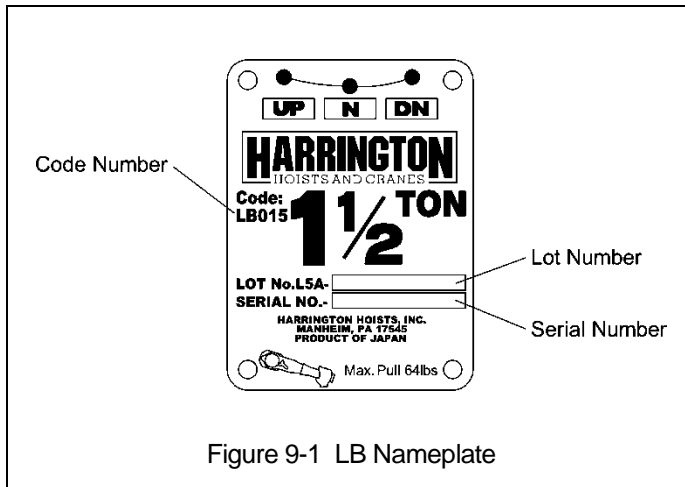

The parts list is arranged into the following sections:

Section	Page
9.1 3/4 to 3 Ton Parts.....	56
9.2 Additional 6 and 9 Ton Parts.....	58
9.3 Optional Parts.....	59

9.1 3/4 to 3 Ton Parts

▲ CAUTION MODEL L4 AND MODEL L5 CHAIN IS NOT INTERCHANGEABLE.

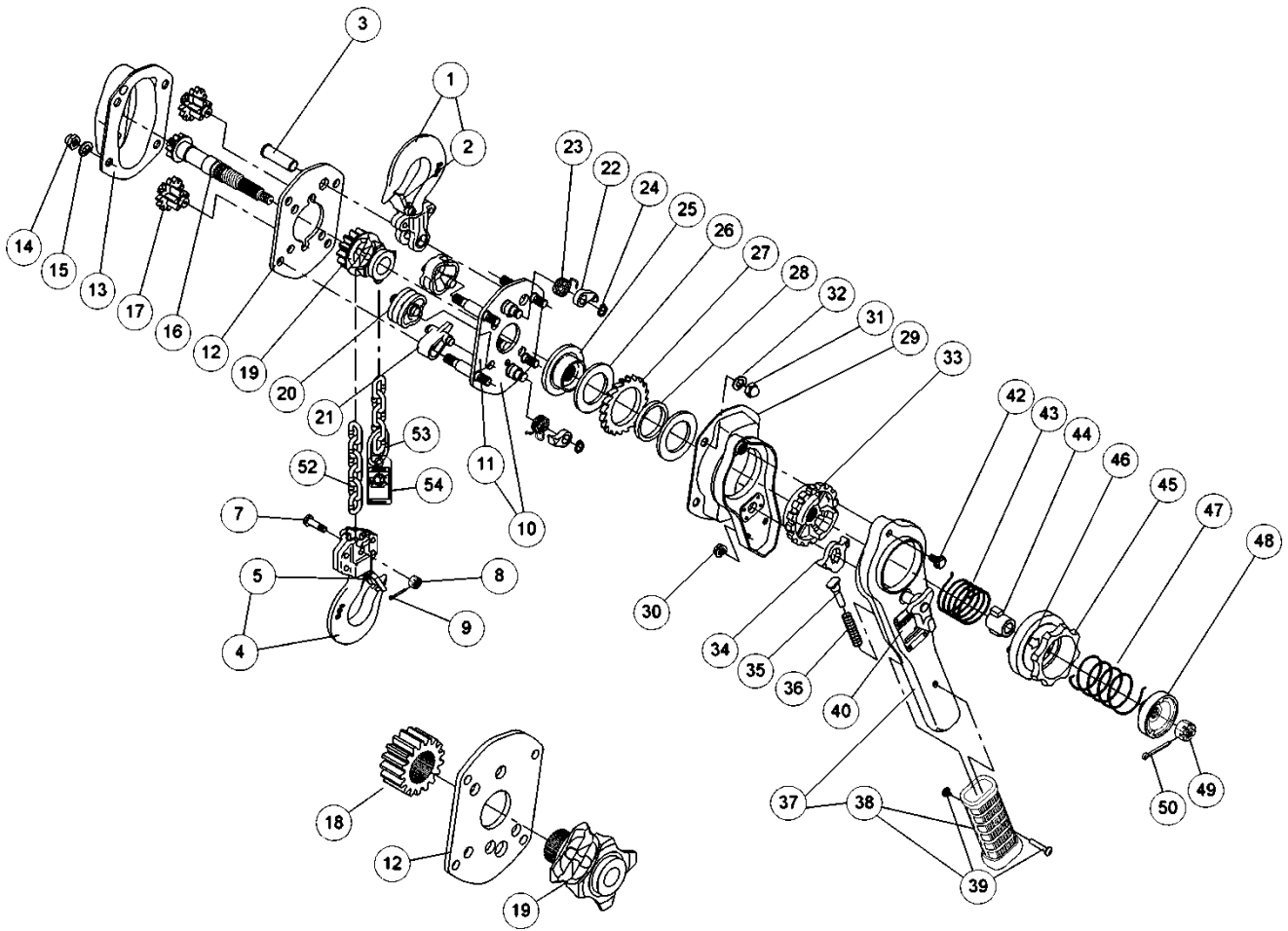

Figure 9-2 3/4 to 3 Ton Parts

9.1 3/4 to 3 Ton Parts

Fig. No.	Name	Parts Per Hoist	3/4 Ton	1 Ton	1 1/2 Ton	2 Ton	2 3/4 Ton	3 Ton
1	Top Hook Comp. Set	1	L5BU0081001	L5BU0101001	L5BU0151001	L5BU0201001	L5BU0281001	L5BU0301001
2	Latch Assembly	1	L5BA0081071	L5BA0101071	L5BA0161071	L5BA0251071		L5BA0321071
3	Top Pin	1	L5BA0089163		L5BA0169163	L5BA0259163		L5BA0329163
4	Bottom Hook Comp. Set	1	L5BU0081021	L5BU0101021	L5BU0151021	L5BU0201021	L5BU0281021	L5BU0301021
5	Latch Assembly	1	L5BA0081071	L5BA0101071	L5BA0161071	L5BA0251071		L5BA0321071
7	Chain Pin	1	L4041008		M3041015	L5BA0259041		L4BH0309041
8	Slotted Nut	1	M3049005		M3049010	M2049020		
9	Split Pin	1	9009402		9009411	9009412		
10	Frame A Assembly	1	L5BA0085101		L5BA0165101	L5BA0255101		L5BA0325101
11	Nameplate F	1	C3BA0059806					
12	Frame B	1	L5BA0089102		L5BA0169102	L5BA0259102		L5BA0329102
13	Gear Case Assembly	1	L5BA0085103		L5BA0165103	L5BA0255103		L5BA0325103
14	Acorn Nut	4	J1ND00530080					
15	Spring Lock Washer	4	9012711					
16	Pinion	1	L5BA0089111		L5BA0169111	L5BA0259111		L5BA0329111
17	Gear #2	2	L5BA0089112		L5BA0169112	L5BA0259112		L5BA0329112
18	Load Gear	1				L5BA0259114		L5BA0329114
19	Load Sheave	1	L5BA0089116		L5BA0169116	L5BA0259116		L5BA0329116
20	Chain Guide	2	L5BA0089161		L5BA0169161	L5BA0259161		L5BA0329161
21	Stripper	1	L5BA0089162		L5BA0169162	L5BA0259162		L5BA0329162
22	Pawl	2	L4155008			L5BA0259155		L4155030
23	Pawl Spring	2	L5BA0089158		L5BA0169158	L5BA0259158		L5BA0329158
24	Snap Ring	2	L4188008					L4188015
25	Friction Disc	1	L5BA0089153					L5BA0329153
26	Friction Plate	2	L4151008					L4151015
27	Ratchet Disc	1	L4152008					L4152015
28	Bushing	1	L4154008					L4154015
29	Brake Cover Assembly	1	L5BA0085214		L5BA0165214	L5BA0255214		L5BA0325214
30	Flange Nut	2	J1NF00210060					J1NE00510080
31	Acorn Nut	4	J1ND00230080					
32	Spring Lock Washer	4	9012711					
33	Female Thread	1	L5BA0089160					L5BA0329160
34	Select Pawl	1	L4218008					L4218015
35	Spring Shaft	1	L4222008					L4222015
36	Change-Over Spring	1	L4223008					L4223015
37	Lever Assembly	1	L5BA0086211		L5BA0166211			L5BA0326211
38	Grip Assembly	1	L5BA0081231		L4BA0081231			L4BA0151231
39	Binding Screw	1	L5BA0089232					
40	Nameplate	1	L5BU0089800	L5BU0109800	L5BU0159800	L5BU0209800	L5BU0289800	L5BU0309800
42	Hex Screw	1	L4221008					L4221015
43	Brake Spring	1	L4207008					L4207015
44	Cam Guide	1	L5BA0089203					L4203015
45	Free Chain Knob	1	L4201008					L4201015
46	Name Plate U	1	L4810008					
47	Free Chain Spring	1	L4205008					L4205015
48	Spring Holder	1	L5BA0089208					L5BA0329208
49	Slotted Nut	1	M2049020					
50	Split Pin	1	9009412					
52	Load Chain	1	LCL5010NP		LCL5015NP	LCL5028NP		LCL5030NP
53	Chain Stopper Link	1	L5BA0089045		L5BA0169045	L5BA0259045		L5BA0329045
54	Warning Tag	1	WTAG9					

9.2 Additional 6 and 9 Ton Parts

CAUTION MODEL L4 AND MODEL L5 CHAIN IS NOT INTERCHANGEABLE.

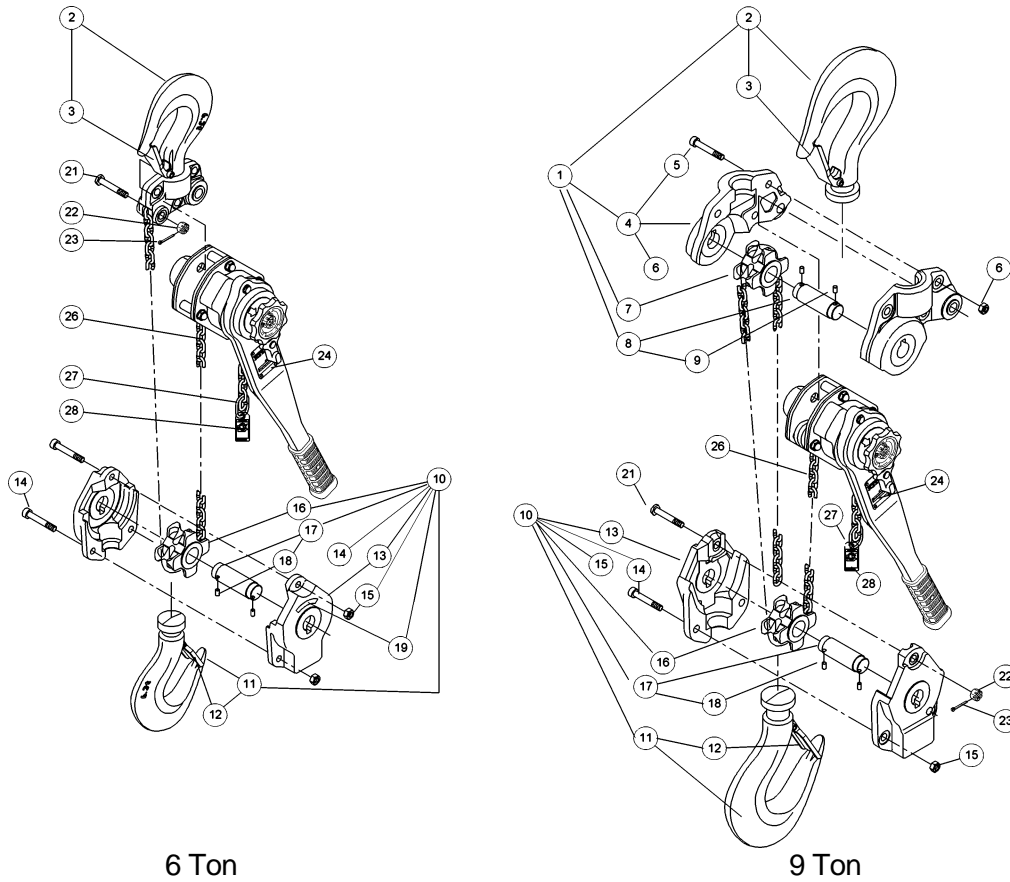

Figure 9-3 6 and 9 Ton Parts

Figure No.	Name	Parts Per Hoist	6 Ton	9 Ton
1	Top Hook Complete Set	1		L5BA0901001
2	Hook Assembly	1	L5BU0601001	L5BA0902001
3	Latch Assembly	1	L5BA0631071	L5BA0901071
4	Top Yoke Assembly	1		L5BA0902011
5	Socket Bolt	3		90912116
6	Lever Nut	3		L4082090
7	Idle Sheave	1		L5BA0639051
8	Shaft Assembly	1		L4053060
9	Shaft Stopper Pin	2		L4083060

Figure No.	Name	Parts Per Hoist	6 Ton	9 Ton
10	Bottom Hook Complete Set	1	L5BU0601021	L5BA0901021
11	Hook Assembly	1	L5BU0602001	L5BA0902001
12	Latch Assembly	1	L5BA0631071	L5BA0901071
13	Bottom Yoke Assembly (2 Halves)	1	L5BA0639031	L5BA0909031
14	Socket Bolt	3	9091296	
		2		90912116
15	Lever Nut	3	L4082060	
		2		L4082090
16	Idle Sheave	1	L5BA0639051	
17	Shaft Assembly	1	L4053060	
18	Shaft Stopper Pin	2	L4083060	
19	Nameplate C	1	80173	
21	Chain Pin	1	L4BH0609041	
22	Slotted Nut	1	M2049020	
23	Split Pin	1	9009412	
24	Nameplate	1	L5BU0609800	L5BU0909800
26	Load Chain	FT	LCL5030NP	
27	Chain Stopper Link	1	L5BA0329045	
28	Warning Tag	1	WTAG9	

9.3 Optional Parts

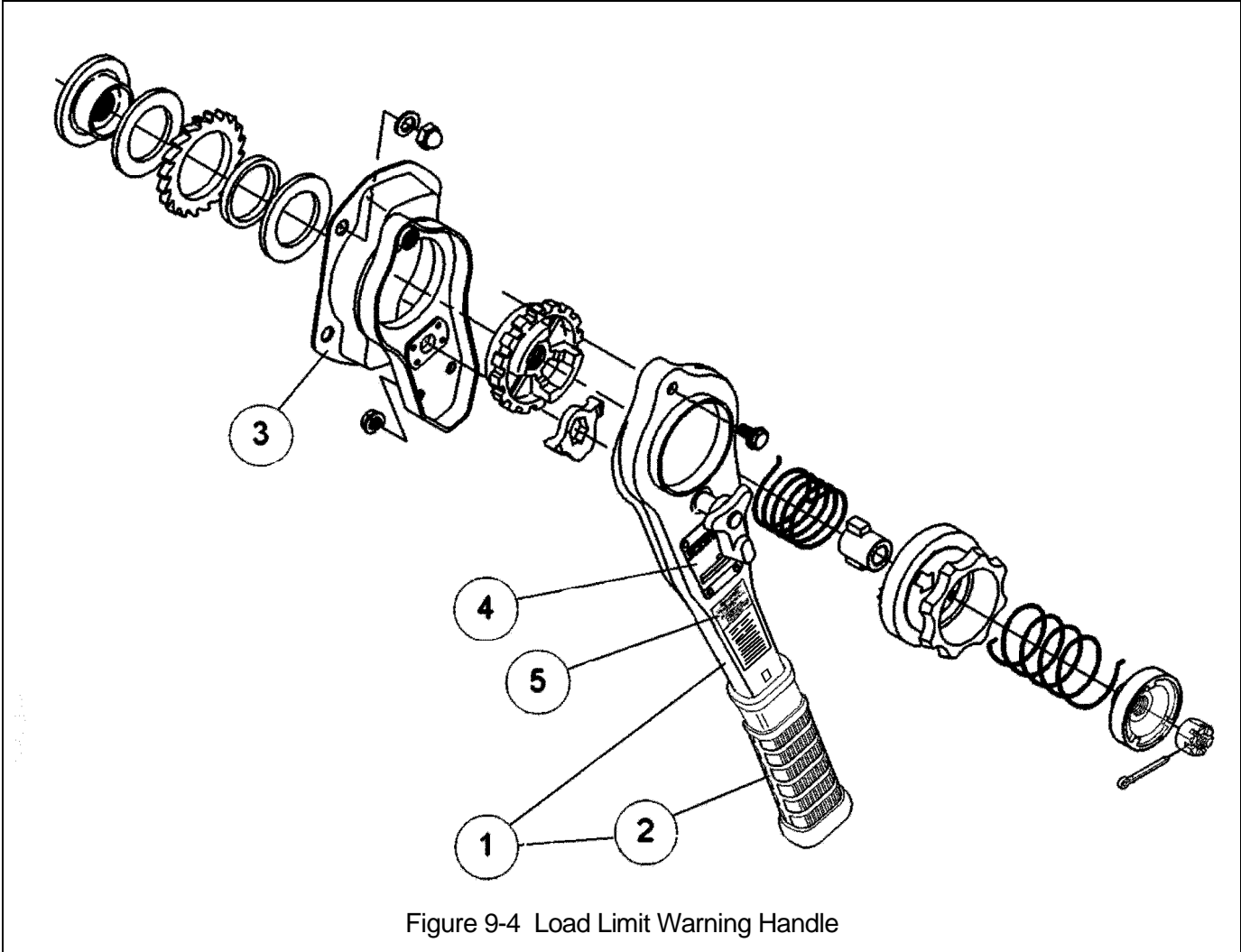

Figure 9-4 Load Limit Warning Handle

Load Limit Warning Handle

Fig. No.	Name	Parts Per Hoist	¾ Ton	1 Ton	1 ½ Ton	2 Ton	2 ¾ Ton	3 Ton	6 Ton	9 Ton
1	Lever Assembly	1	Y3SU008-6211	Y3SU010-6211	Y3SU015-6211	Y3SU020-6211	Y3SU028-6211	Y3SU030-6211		
2	Grip Assembly	1	L4231S008							
3	Brake Cover	1	Y3SE0085214							
4	Name Plate w/rivets	1	Y3SU008-9800	Y3SU010-9800	Y3SU015-9800	Y3SU020-9800	Y3SU028-9800	L5BU030-9800	L5BU060-9800	L5BU090-9800
5	LLWH Warning Label	1	80175							

9.3 Optional Parts

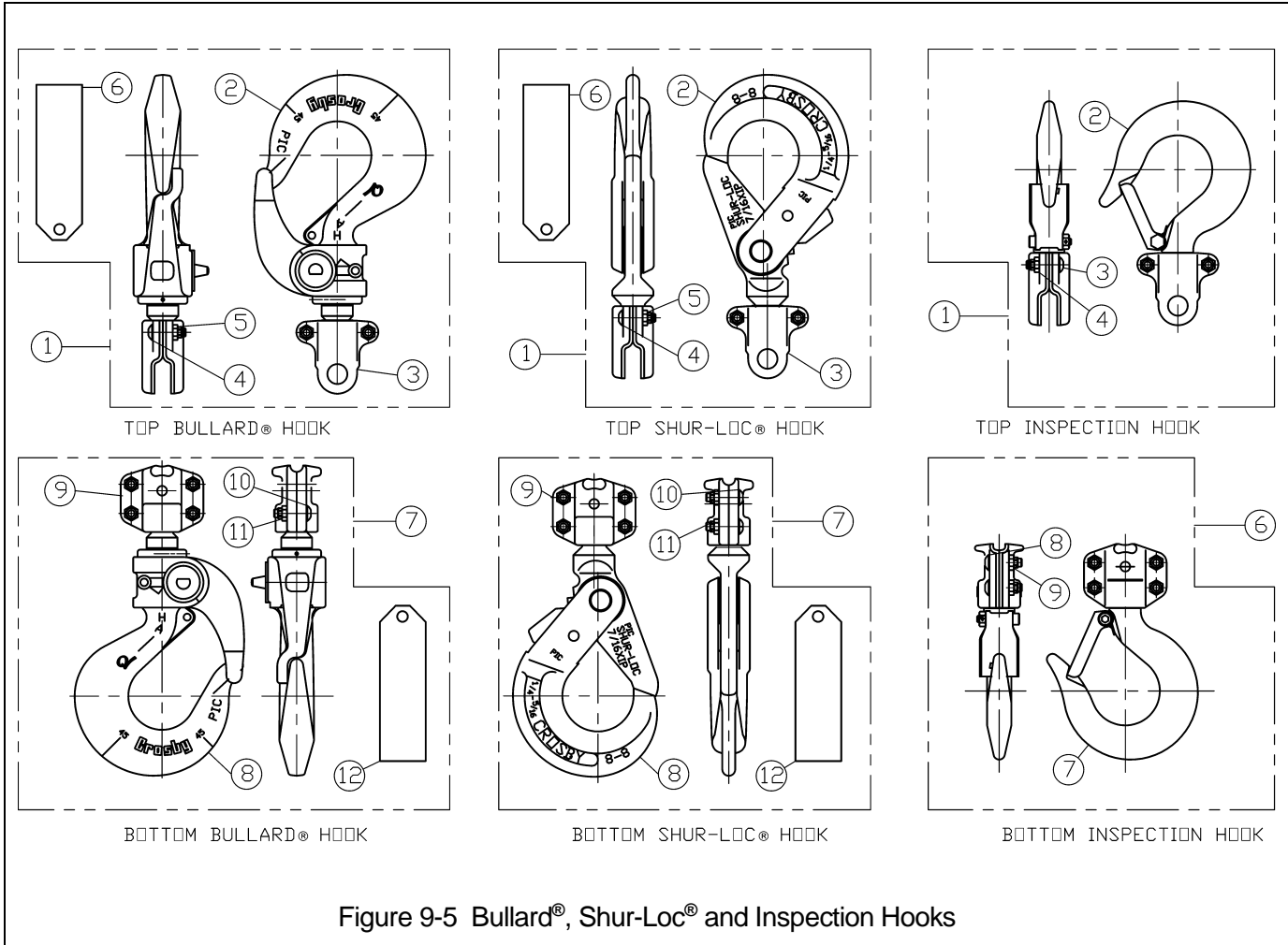

Figure 9-5 Bullard®, Shur-Loc® and Inspection Hooks

Bullard® Hooks

Fig. No.	Name	Parts Per Hoist	¾ Ton	1 Ton	1 ½ Ton	2 Ton	2 ¾ Ton	3 Ton	6 Ton	9 Ton
1	Bullard® Top Hook Complete Set	1	6028405	6028406	6028407	6028408				6028404
2	Bullard® Hook Assembly	1	60161	60163	60722	60167				60171
3	Top Yoke Kit	1	TYKITL5008	TYKITL5015	TYKITL5028	TYKITL5030				
4	Button Head Screw	2	9012612		9012602					
5	Flexloc® Nut	2	9012613		9012604					
6	Warning Tag	1	WTAG6*							
7	Bullard® Bottom Hook Complete Set	1	6028908	6028909	6028910	6028911	6028906	6028907		
8	Bullard® Hook Assembly	1	60161	60163	60722	60167	60170	60171		
9	Bottom Yoke Kit	1	BYKITL5008	BYKITL5015	BYKITL5028	BYKITL5030				
10	Button Head Screw	4	9012612		9012602					
11	Flexloc® Nut	4	9012613		9012604					
12	Warning Tag*	1	WTAG6*							

*Hoist with Bullard® Hook(s) must have WTAG6 and WTAG9 installed. (See page 51 for WTAG9).

9.3 Optional Parts

Shur-Loc® Hooks

Fig. No.	Name	Parts Per Hoist	¾ Ton	1 Ton	1 ½ Ton	2 Ton	2 ¾ Ton	3 Ton
1	Shur-Loc® Top Hook Complete Set	1	6030004		6030005		6030006	6030007
2	Shur-Loc® Hook Assembly	1	60141		60143		60723	60147
3	Top Yoke Kit	1	TYKITL5008		TYKITL5015		TYKITL5028	TYKITL5030
4	Button Head Screw	2	9012612			9012602		
5	Flexloc® Nut	2	9012613			9012604		
6	Warning Tag	1	WTAG6*					
7	Shur-Loc® Bottom Hook Complete Set	1	6029906		6029907		6029908	6029909
8	Shur-Loc® Hook Assembly	1	60141		60143		60723	60147
9	Bottom Yoke Kit	1	BYKITL5008		BYKITL5015		BYKITL5028	BYKITL5030
10	Button Head Screw	4	9012612			9012602		
11	Flexloc® Nut	4	9012613			9012604		
12	Warning Tag	1	WTAG6*					

*Hoist with Shur-Loc® Hook(s) must have WTAG6 and WTAG9 installed. (See page 51 for WTAG9).

Inspection Hooks

Fig. No.	Name	Parts Per Hoist	¾ Ton	1 Ton	1 ½ Ton	2 Ton	2 ¾ Ton	3 Ton
1	Top Hook Complete Set	1	6073301	6073302	6073303	6073304	6073305	6073306
2	Hook W/Latch & Yoke	1	THKITL5008	THKITL5010	THKITL5015	THKITL5020	THKITL5028	THKITL5030
3	Button Head Screw	2	9012612			9012602		
4	Flexloc® Nut	2	9012613			9012604		
6	Bottom Hook Complete Set	1	6073401	6073402	6073403	6073404	6073405	6073406
7	Hook W/Latch & Yoke	1	BHKITL5008	BHKITL5010	BHKITL5015	BHKITL5020	BHKITL5028	BHKITL5030
8	Button Head Screw	2	9012612			9012602		
9	Flexloc® Nut	2	9012613			9012604		

9.3 Optional Parts

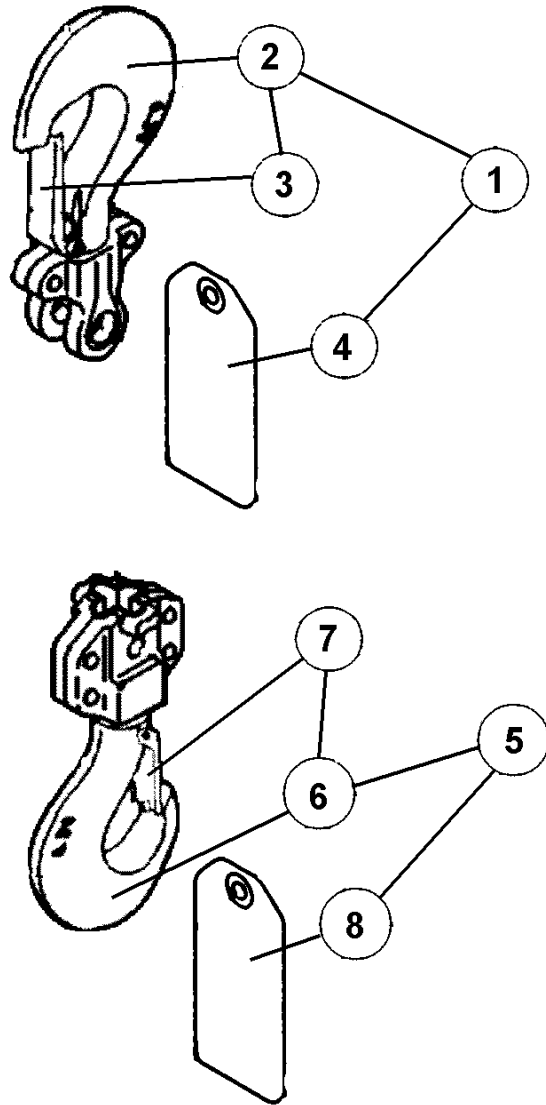

Figure 9-6 Shipyard Hooks

Shipyard Hooks

Fig. No.	Name	Parts Per Hoist	1 ½ Ton	2 ¾ Ton	3 Ton
1	Top Hook Complete Set	1	6078005	6031001	6078007
2	Top Hook Assembly	1	L5BZ0151001	L5BZ0251001	L5BZ0301001
3	Latch Assembly	1	L5BZ0151071	L5BZ0301071	
4	Warning Tag	1	WTAG6*		
5	Bottom Hook Complete Set	1	6078006	6031002	6078008
6	Bottom Hook Assembly	1	L5BZ0151021	L5BZ0251021	L5BZ0301021
7	Latch Assembly	1	L5BZ0151071	L5BZ0301071	
8	Warning Tag	1	WTAG6*		

*Hoist with Shipyard Hook(s) must have WTAG6 and WTAG9 installed. (See page 51 for WTAG9).

9.3 Optional Parts

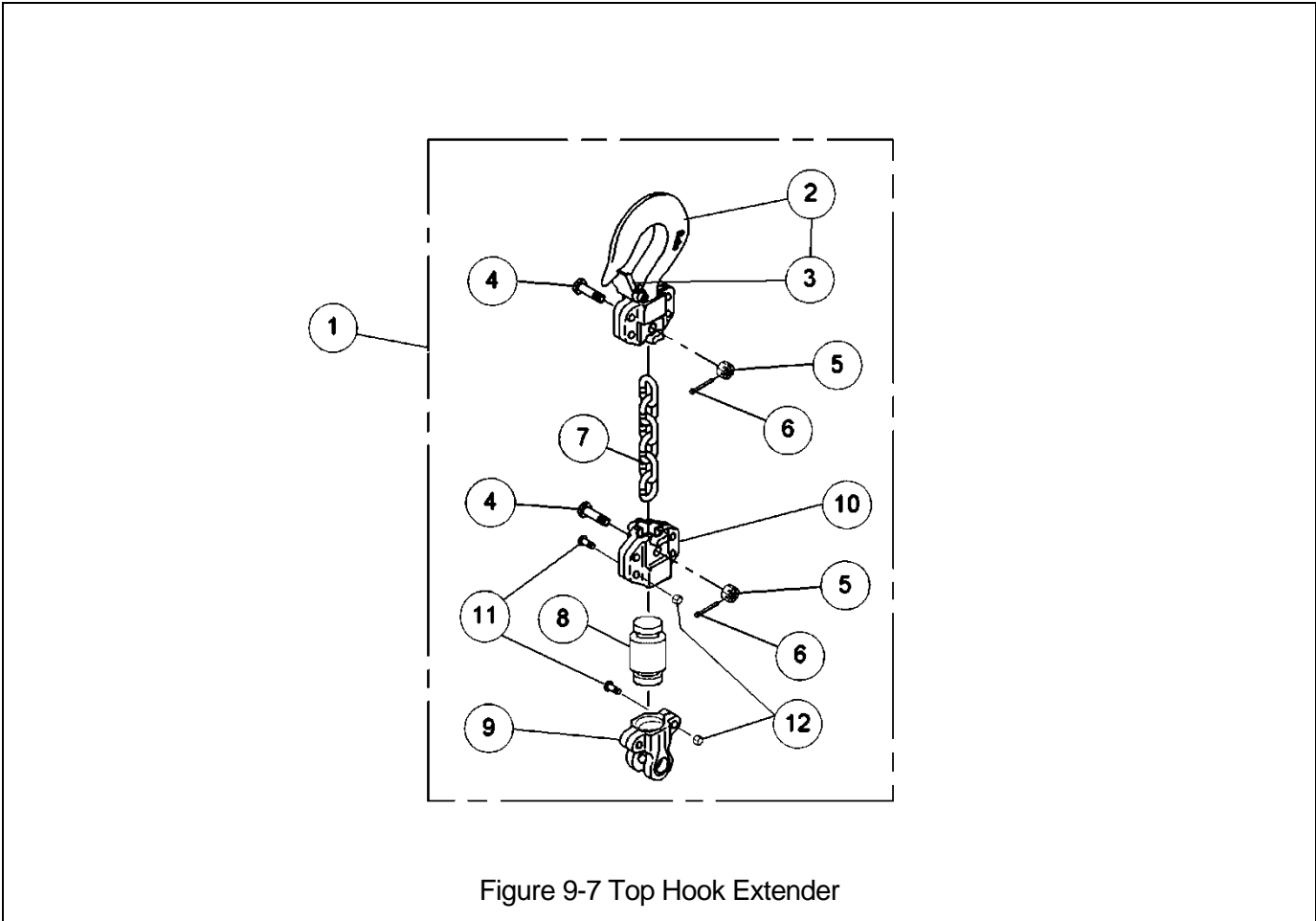
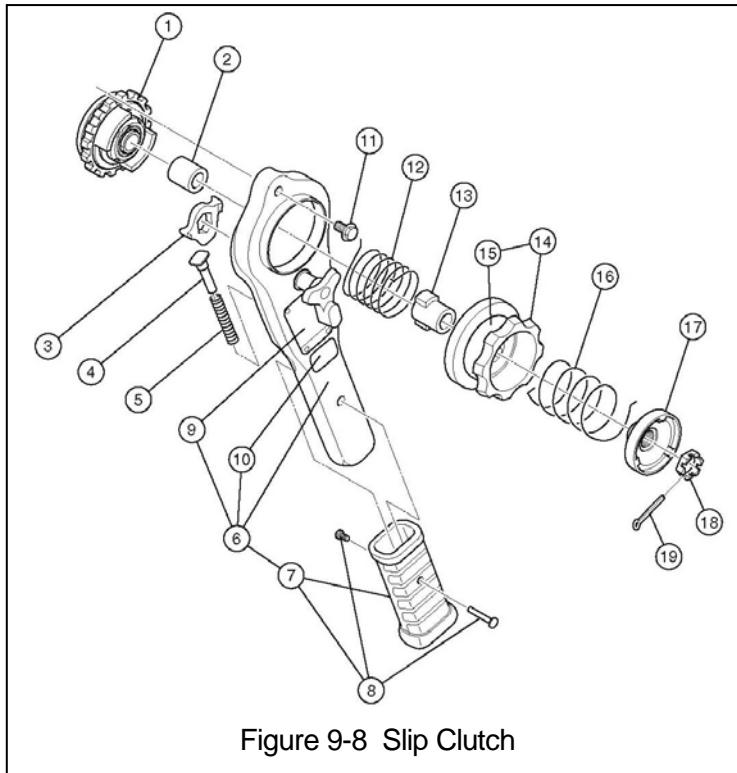

Figure 9-7 Top Hook Extender

Top Hook Extender

Fig. No.	Name	Parts Per Hoist	¾ Ton	1 Ton	1 ½ Ton	2 Ton	2 ¾ Ton	3 Ton
1	Top Hook Extender	1	6073001	6073002	6073003	6073004	6073005	6073006
2	Bottom Hook Assembly	1	L5BU0081021	L5BU0101021	L5BU0151021	L5BU0201021	L5BU0281021	L5BU0301021
3	Latch Assembly	1	L5BA0081071	L5BA0101071	L5BA0161071	L5BA0251071		L5BA0321071
4	Chain Pin	1	L4041008		M3041015	L5BA0259041		L4BH0309041
5	Slotted Nut	1	M3049005		M3049010	M2049020		M2049020
6	Split Pin	1	9009402		9009411	9009412		
7	Load Chain	FT	LCL5010NP		LCL5015NP	LCL5028NP		LCL5030NP
8	Extension Block	1	60738		60735	60736		60737
9	Top Yoke Kit	1	TYKITL5008		TYKITL5015	TYKITL5028		TYKITL5030
10	Bottom Yoke Kit	1	BYKITL5008		BYKITL5015	BYKITL5028		BYKITL5030
11	Button Head Screw	6	9012601		9012602			
12	Flexloc® Nut	6	9012603		9012604			

9.3 Optional Parts



Slip Clutch

Fig. No.	Part Name	Parts per Hoist	Capacity (Tons)							
			¾	1	1½	2	2¾	3	6	9
1	Friction Clutch	1	L5FA0085301				L5FA0325301			
2	Spacer	1	L5FA0089310				L5FA0329310			
3	Select Pawl	1	L4218008				L4218015			
4	Spring Shaft	1	L4222008				L4222015			
5	Select Pawl Spring	1	L4223008				L4223015			
6	Lever Assembly	1	L5BA0086211		L5BA0166211		L5BA0326211			
7	Grip	1	L5BA0081231		L4BA0081231		L4BA0151231			
8	Binding Screws	1	L5BA0089232				L5BA0329232			
9	Nameplate	1	L5BU00-89800	L5BU01-09800	L5BU01-59800	L5BU02-09800	L5BU02-89800	L5BU03-09800	L5BU06-09800	L5BU09-09800
10	Warning Label	1	L5FA0089921		L5FA0169921		L5FA0329921			
11	Hex Cap Screw	1	L4221008				L4221015			
12	Brake Spring	1	L5FA0089207				L5FA0329207			
13	Cam Guide	1	L5FA0089203				L5FA0329203			
14	Free Chain Knob	1	L5FA0089201				L5FA0329201			
15	Nameplate U	1	L4810008							
16	Free Chain Spring	1	L5FA0089205				L5FA0329205			
17	Spring Holder	1	L5FA0089208				L5FA0329208			
18	Slotted Nut	1	M2049020							
19	Split/Cotter Pin	1	9009412							

NOTES

NOTES

NOTES



Harrington Hoists, Inc.
401 West End Avenue
Manheim, PA 17545

www.harringtonhoists.com

Toll Free: 800-233-3010
Phone: 717-665-2000
Fax: 717-665-2861

L5LBOM-ENG