

HARRINGTON

A KITO GROUP COMPANY



Electric Chain Hoists

Working Harder For You

In 1876, Edwin Harrington dramatically improved the self-sustaining hoist by introducing the worm-gear design. Since then, the company he founded has earned a proud reputation for product innovations and consistent quality that our customers count on to meet their diverse requirements.

Over the years we have developed and grown by recognizing the value of our customers and responding to your needs. The daily mission of our organization is to provide you, the customer, with the highest quality in our products, service and support.

In addition to our superior products and expanded facilities, we offer a Sales and Customer Service team that is dedicated to serving you, a well qualified Engineering Department to support your technical needs and a full support staff who all know the importance of working together to provide solutions for your material handling projects.

We are working harder to be the supplier-of-choice for all of your hoist and crane applications.

Table of Contents

NER/ER Electric Chain Hoists	
Enhanced Features	4
Features and Benefits	6
NER/ER Electric Chain Hoists	
Standard Specifications and Dimensions	8
NERM/ERM Electric Chain Hoists With Motorized Trolleys	
Standard Specifications and Dimensions	14
MR Motorized Trolleys	
Features and Benefits	21
NERP/ERP and NERG/ERG Electric Chain Hoists With Push or Geared Trolleys	
Standard Specifications and Dimensions	22
NER/ER Large Capacity Electric Chain Hoists	
Standard Specifications and Dimensions	30
NERM/ERM Large Capacity Electric Chain Hoists With Motorized Trolleys	
Standard Specifications and Dimensions	34
NERP/ERP and NERG/ERG Large Capacity Electric Chain Hoists With Push or Geared Trolleys	
Standard Specifications and Dimensions	38
NER Dual Speed Electric Chain Hoists Smart Limit Option	
Standard Specifications and Dimensions	42
NER/ER Cylinder Control Electric Chain Hoists	
Standard Specifications and Dimensions	44
SNER Electric Chain Hoists With Motorized, Push or Geared Trolleys	
Features and Benefits	46
Standard Specifications and Dimensions	46
ED Electric Chain Hoists	
Features and Benefits	50
Standard Specifications and Dimensions	50
ET Mini Trolley	53
Options and Technical Data	54
Product Code	60
Complete Product Offering	63

Electric Chain Hoists

Enhanced Features

UL® Listed*

Certified and listed to UL 1340 "Standard for Hoists."



Easy Access Suspension

External pins allow for quick change from hook to lug for trolley mount configurations on most models.



Perpendicular Orientation

PT push trolley mount and MR motorized trolley mount hoists are configured as perpendicular to the beam on single fall models. Parallel mount is available as an option.



High Strength, Corrosion and Wear Resistant Load Chain

Grade 80, super strength, nickel-plated load chain, certified to DIN standards, uses unique technology to greatly increase resistance to fatigue and wear.



Green Initiative

Built smarter without the use of harmful materials. Environmentally friendly. RoHS compliant.



Notched Hook and Latch System

Provides positive closing and improves resistance against lateral forces standard on most models.



Unique Load Sheave

Increased number of pockets reduce chain vibration and increase chain life. 5 pockets standard; 6 pockets on smaller body hoists.



Extended Chain Life

Decreased chain wear as a result of a revolutionary heat treatment process, improved material and chain size.

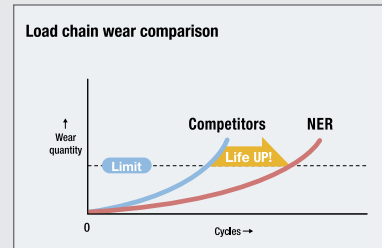

*Most models shipped with UL listing. Contact Customer Service for listed models.

Limit Switches

Low-profile upper and lower limit switches are standard.

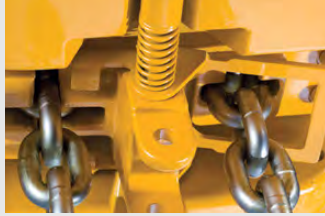

Contactors

Mechanically interlocked, heavy-duty contactors on single speed models.

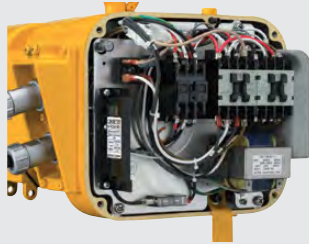

Friction Clutch and Load Brake

Friction clutch is standard on NER/ER models and friction clutch with mechanical load brake standard on ER models. Carbon friction material provides consistent performance over a wide temperature range.



High Air Flow

Cooler motor and brake attributed to an engineered motor fin, fan blade and fan cover design.



Standard Count Hour Meter

Records and displays the number of lowering starts and hoist on time which is valuable for preventive maintenance. Integral to VFD on dual speed models.



Dual Speed VFD

Under-the-cover VFD standard for dual speed hoists. Speed ratio is 6:1 with adjustability up to 12:1.



“The Guardian” Smart Brake Technology

A current driven electromagnetic brake does not release unless the motor is energized. **10 year hoist brake warranty.**

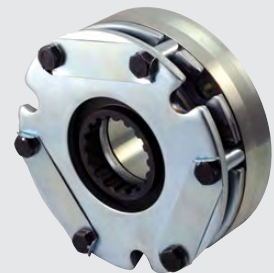

Pendant Controls

Ergonomic design for operator comfort. Red button emergency stop is standard on all 4-button and on 2-button dual speed pendants.



Electric Chain Hoists

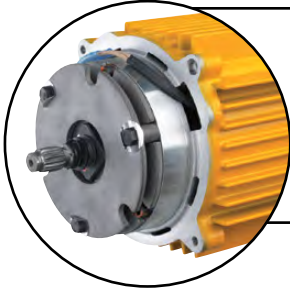

“The Guardian”: Smart Brake Technology
Revolutionary DC current motor brake with electrical failsafe design. **10 year warranty.**

Suspension

Hoist is easily changed from hook to lug mount configurations with external suspension pins on most models.

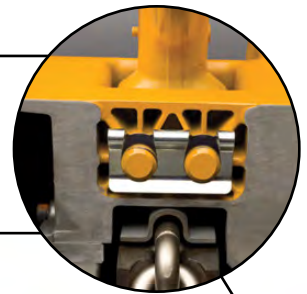

Totally Enclosed Fan Cooled (TEFC) Motor

Engineered motor fin, fan blade and fan cover design cools the motor and brake.

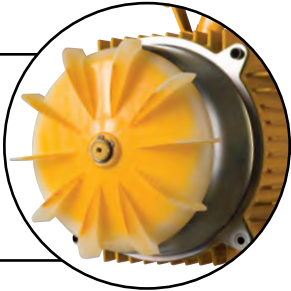

Extreme Duty Motor

Increased performance through 60 minute duty rating, H4 classification, Class B insulation, cooling fins and standard thermal motor protection. Offers higher horsepower than most competitors.



Durable Push Button Pendant

Easy to use, one-handed operation. Rated IP65. Standard control voltage is 110V. Strain relief wire is molded to pendant cord for added support and dependability. E-stop is standard on all 4-button pendants and on 2-button dual speed pendants.

Upper/Lower Limit Switches

Low profile upper and lower limit switches provide excellent headroom.

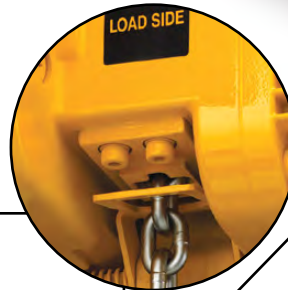

Load Sheave

5 or 6 deep-groove pockets fully support the load chain during operation. Reduces vibration and chain wear. Provides true vertical lift.

Forged Carbon Steel Hooks

Under excessive loads will open gradually and not fracture. Ball bearings produce smooth rotation. Bottom hook will swivel 360 degrees. Heavy-duty hook latches are standard.

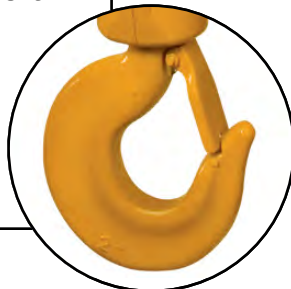

Unique Chain Guide

Provides quiet and smooth guiding of chain. Easily replaced without hoist disassembly. Heavy cast iron construction for improved wear versus stamped steel design offered by many manufacturers.

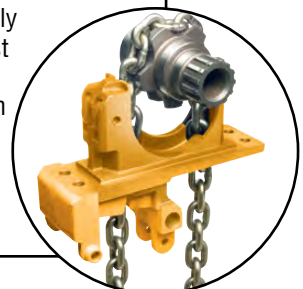

Heat Treated Helical and Spur Gears

Precision machined for long life. Oil bath lubrication results in a quiet, smooth, cool operation.

Mechanical Load Brake

Mechanical (secondary) Weston-style load brake standard on ER models.

Long Life Friction Clutch

Protects hoist from damage and prevents overwinding. ER model couples Weston-style load brake with friction clutch.

Compact Aluminum Body

Die-cast body is lightweight and offers low headroom – one of the best in the industry. Paint is electrostatically applied.

Completely Sealed Body

Suitable for both indoor and outdoor applications, including harsh environments. (Consult Owner's Manual for details.) Gaskets throughout the hoist provide for an IP55 rating.

Contactors

Mechanically interlocked heavy-duty contactors (single speed).

Variable Frequency Drive

Dual speed controls via "under-the-cover" variable frequency drive standard. Optional 2-step and 3-step infinitely variable control.

Count Hour Meter

This maintenance feature tracks motor starts, running time and usage history by instant digital display. Meter operates independently of the hoist. Integral to VFD on dual speed models.

Easy Maintenance Control Panel

Simple layout of controls and a single swing-down panel. Captured control cover provides standard wiring diagram and allows fast on-site access.

Plug-in Connections

Saves valuable time on set up and maintenance. "Quick disconnect" replaces typical competitive hard-wired designs.

Corrosion Resistant Load Chain

Nickel-plated, Grade 80, DIN chain for superb durability and strength.

Operating Conditions

Recommended for -4° to +104° F and humidity of 85% or less.

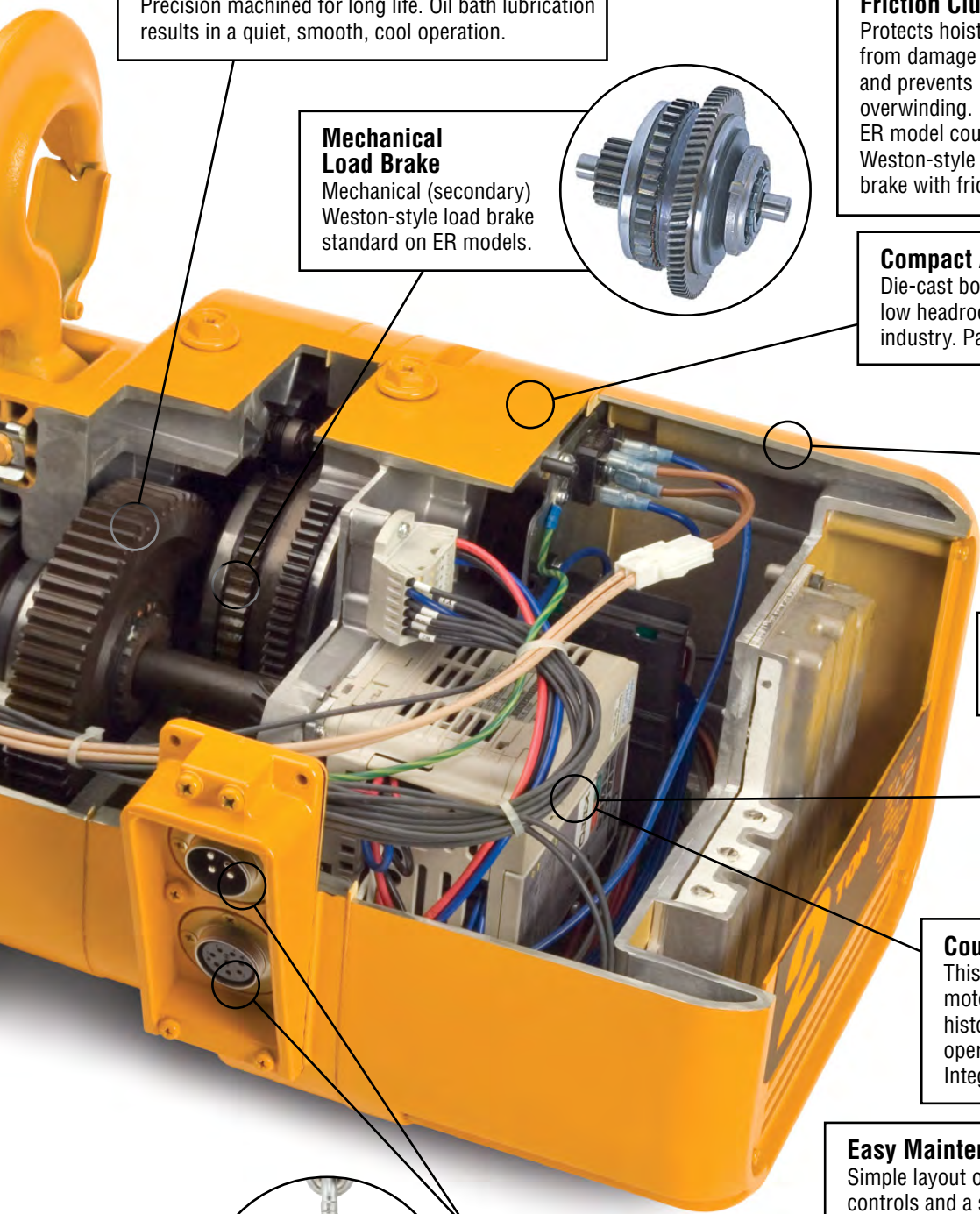
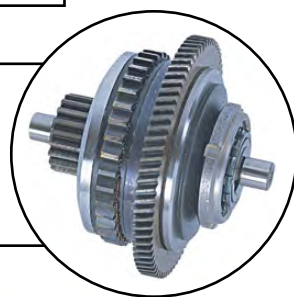
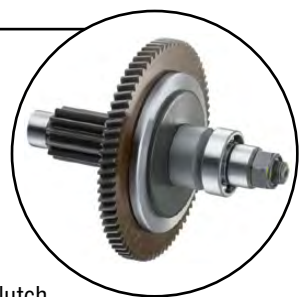

NER/ER Electric Chain Hoists with Hook and Lug Suspensions



NER/ER010L
(Shown with optional
canvas chain container)

We have added several new features and upgrades to our NER/ER Series of electric chain hoists. These improvements to our high quality, full-featured hoist include the latest technologies making these models absolutely the best electric chain hoists in the market today.

Features and Benefits

UL® Listed**

Certified and listed to UL 1340 “Standard for Hoists.”

Easy Access Suspension

External pins allow for quick change from hook to lug for trolley mount configurations on most models.

Green Initiative

Built smarter without the use of harmful materials. Environmentally friendly. RoHS compliant.

Notched Hook and Latch System

Provides positive closing and improves resistance against lateral forces.

Limit Switches

Low-profile upper and lower limit switches are standard.

Extended Chain Life

Decreased chain wear as a result of a revolutionary heat treatment process, improved material and chain size.

High Air Flow

Cooler motor and brake attributed to an engineered motor fin, fan blade and fan cover design.

Unique Load Sheave

Increased number of pockets reduce chain vibration and increase chain life. 5 pockets standard; 6 pockets on smaller body hoists.

Friction Clutch and Load Brake

Friction clutch is standard on NER/ER models and friction clutch with mechanical load brake standard on ER models. Carbon friction material provides consistent performance over a wide temperature range.

Standard Count Hour Meter

Records and displays the number of lowering starts and hoist on time which is valuable for preventive maintenance. Integral to VFD on dual speed models.

Contactors

Mechanically interlocked, heavy-duty contactors on single speed models.

High Strength, Corrosion and Wear Resistant Load Chain

Grade 80, super strength, nickel-plated load chain, certified to DIN standards, uses unique technology to greatly increase resistance to fatigue and wear.

Dual Speed VFD

Under-the-cover VFD standard for dual speed hoists. Speed ratio is 6:1 with adjustability up to 12:1.

“The Guardian”: Smart Brake Technology

A current driven electromagnetic brake does not release unless the motor is energized. 10 year hoist brake warranty.

Pendant Controls

Ergonomic design for operator comfort. Red button emergency stop is standard on all 2-button dual speed pendants.

Standard Hoist Specifications

Capacity Range

NER/ER – 1/8 Ton – 5 Ton
(See page 30 for 8 – 20 Ton)

Standard Voltage

208-230 / 460-3-60
Optional voltages available
Dual speed models are not reconnectable

Control Voltage

110V (optional 24V)

Duty Cycle*

Single Speed – 60 Min.
Dual Speed – 30/10 Min. with VFD

Classification*

ASME H4
ISO M5 or M4
FEM 2m or 1Am

Conformance**

UL 1340

Ratings

Hoist – IP55
Pendant – IP65

Upper/Lower Limit Switch

Overwinding/overlifting device
Standard on all models

Chain Falls***

Single chain fall through 3 Ton

Standard Lift

10' (longer lifts available)

Standard Pendant Drop

Standard pendant hangs approximately 4' above the hoist's fully extended bottom hook (longer lengths available)

Standard Power Supply Length

15' (longer lengths available)

Mounting

Hook, lug or trolley

Standard Pendants

Single speed: 2-button (momentary contacts)
Dual speed: 2-button (momentary contacts) with emergency On/Off (maintained contacts)

Chain Containers

Optional
Canvas, plastic or steel

Operating Conditions

Recommended for -4° to +104° F and humidity of 85% or less.

NER vs. ER Features

ER model has same high-quality features as NER plus the following:

- Second brake—Weston-style mechanical load brake

*See page 59 for additional information.

**Most models shipped with UL listing. Contact Customer Service for listed models.

***The 3 Ton (N)ER030L is the previous hoist model.



NER/ER010L
(Shown with optional
canvas chain container)

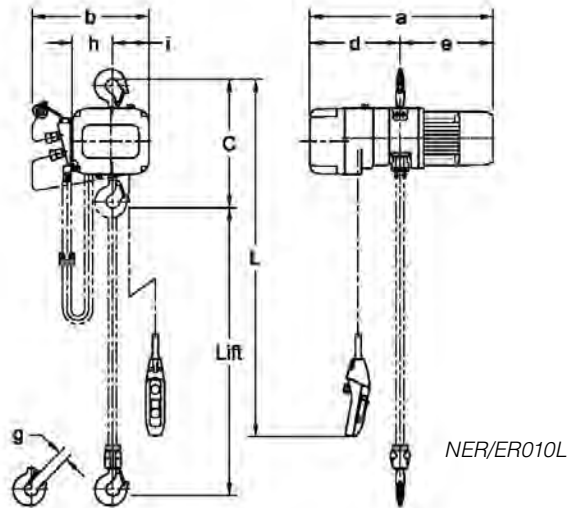

NER/ER010L

SINGLE SPEED — SPECIFICATIONS

Cap. (Tons)	Product Code	Standard Lift (ft)	Push Button Cord L (ft)	Lifting Speed (ft/min)	Lifting Motor 3 Phase 60 Hz			Load Chain Diameter (mm) x Chain Fall Lines	Net Weight (lbs)		Weight for Additional One Foot of Lift (lbs)
					Output (Hp)	Rated Current (amps)			NER	ER	
						@208 - 230V	@460V				
1/8	(N)ER001H	10	8.2	55	0.75	3.4	1.7	4.3 x 1	60	62	0.28
1/4	(N)ER003S			36	0.75	3.4	1.7	4.3 x 1	60	62	0.28
1/4	(N)ER003H			53	1.2	4.8	2.5	6.0 x 1	79	82	0.54
1/2	(N)ER005L			15	0.75	3.4	1.7	6.0 x 1	71	79	0.54
1/2	(N)ER005S			29	1.2	4.8	2.5	6.0 x 1	79	82	0.54
1	(N)ER010L			14	1.2	4.8	2.5	7.7 x 1	104	110	0.89
1	(N)ER010S			28	2.4	8.6	4.2	7.7 x 1	119	119	0.89
1 1/2	(N)ER015S			18	2.4	8.6	4.2	10.2 x 1	159	170	1.6
2	(N)ER020C			7	1.2	4.8	2.5	7.7 x 2	130	134	1.8
2	(N)ER020L			14	2.4	8.6	4.2	10.2 x 1	161	174	1.6
2	(N)ER020S			28	4.7	16.4	7.9	10.2 x 1	201	198	1.6
2 1/2	(N)ER025S			22	4.7	16.4	7.9	11.2 x 1	227	225	1.9
3	(N)ER030L*			16	4.7	18.3	9.2	12.5 x 1	256	256	2.3
3	(N)ER030C			9.2	9.2	17	4.7	16.4	7.9	10.2 x 2	234
5	(N)ER050L	11	4.7			16.4	7.9	11.2 x 2	289	284	3.8

*The (N)ER030L listed is the previous hoist model. Refer to Harrington catalog C-EPH for features and benefits.

NER/ER Electric Chain Hoists with Hook and Lug Suspensions



NER/ER020L
(Shown with optional canvas chain container)

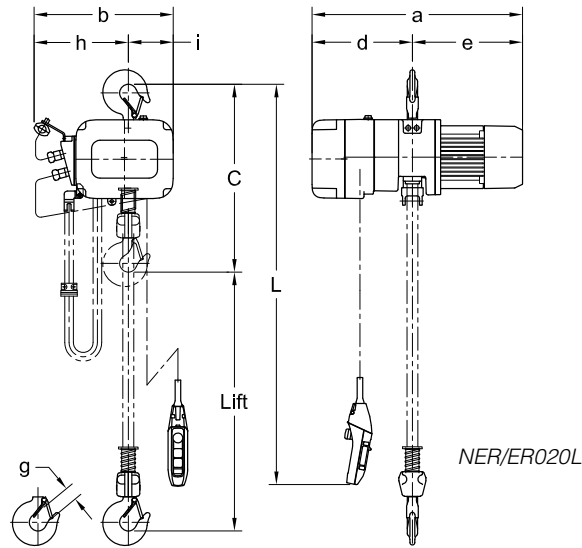

NER/ER020L

SINGLE SPEED — DIMENSIONS

Cap. (Tons)	Product Code	Headroom C (in)	a (in)		b (in)		d (in)		e (in)		g (in)	h (in)	i (in)	
			NER	ER	NER	ER	NER	ER	NER	ER			NER	ER
1/8	(N)ER001H	13.8	18.8	22.2	12.6	13.6	8.6	12.0	10.2	10.2	1.1	3.9	3.7	4.6
1/4	(N)ER003S	13.8	18.8	22.2	12.6	13.6	8.6	12.0	10.2	10.2	1.1	3.9	3.7	4.6
1/4	(N)ER003H	14.6	20.0	23.3	13.7	13.7	9.5	12.8	10.5	10.5	1.1	4.4	4.2	4.2
1/2	(N)ER005L	14.6	20.2	23.5	13.7	13.7	9.5	12.8	10.6	10.7	1.1	4.4	4.2	4.2
1/2	(N)ER005S	14.6	20.0	23.3	13.7	13.7	9.5	12.8	10.5	10.5	1.1	4.4	4.2	4.2
1	(N)ER010L	16.9	23.2	24.9	14.8	14.8	11.4	13.1	11.7	11.8	1.2	5.1	4.6	4.6
1	(N)ER010S	16.9	23.5	25.2	14.8	14.8	11.4	13.1	12.1	12.1	1.2	5.1	4.6	4.6
1 1/2	(N)ER015S	20.1	25.4	29.0	16.8	16.8	12.1	15.6	13.3	13.4	1.4	6.3	5.4	5.4
2	(N)ER020C	27.8	23.2	24.9	14.8	14.8	11.4	13.1	11.7	11.8	1.5	7.0	2.7	2.7
2	(N)ER020L	22.6	25.4	29.0	16.8	16.8	12.1	15.6	13.3	13.4	1.6	6.3	5.4	5.4
2	(N)ER020S	23.2	27.6	30.8	16.8	16.8	13.6	16.8	14.0	14.0	1.6	6.3	5.4	5.4
2 1/2	(N)ER025S	24.6	28.9	32.5	17.5	17.5	13.2	16.8	15.7	15.7	1.6	6.8	5.6	5.6
3	(N)ER030L*	26.0	30.9	30.9	18.9	18.9	15.5	15.5	15.5	15.5	1.7	7.2	6.5	6.5
3	(N)ER030C	30.9	27.6	30.8	16.8	16.8	13.6	16.8	14.0	14.0	1.8	8.5	3.2	3.2
5	(N)ER050L	33.5	28.9	32.5	17.5	17.5	13.2	16.8	15.7	15.7	1.9	9.1	3.3	3.3

*The (N)ER030L listed is the previous hoist model. Refer to Harrington catalog C-EPH for features and benefits.



NER/ER010LD
(Shown with optional canvas chain container)

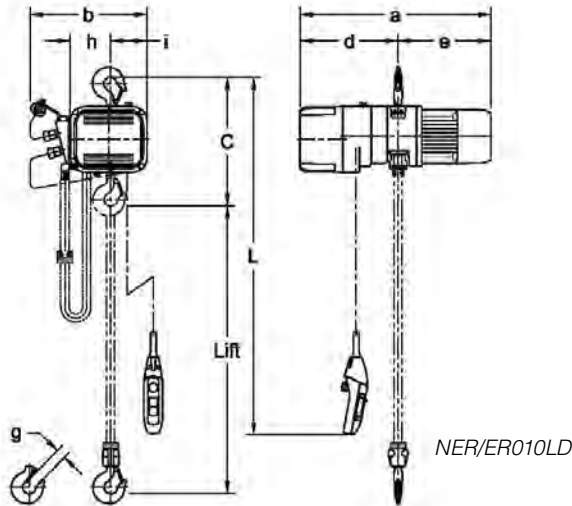

NER/ER010LD

DUAL SPEED — SPECIFICATIONS

Cap. (Tons)	Product Code	Standard Lift (ft)	Push Button Cord L (ft)	Lifting Speed (ft/min)	Lifting Motor 3 Phase 60 Hz†			Load Chain Diameter (mm) x Chain Fall Lines	Net Weight (lbs)		Weight for Additional One Foot of Lift (lbs)
					Output (Hp)	Rated Current (amps)			NER	ER	
						@208 - 230V	@460V				
1/8	(N)ER001HD	10	8.2	55/9	0.75	3.6	1.8	4.3 x 1	60	64	0.28
1/4	(N)ER003SD			36/6	0.75	3.6	1.8	4.3 x 1	60	64	0.28
1/4	(N)ER003HD			53/9	1.2	5.1	2.7	6.0 x 1	77	82	0.54
1/2	(N)ER005LD			15/2.5	0.75	3.6	1.8	6.0 x 1	68	79	0.54
1/2	(N)ER005SD			29/5	1.2	5.1	2.7	6.0 x 1	77	82	0.54
1	(N)ER010LD			14/2.5	1.2	5.1	2.7	7.7 x 1	99	108	0.89
1	(N)ER010SD			28/4.5	2.4	9.1	4.5	7.7 x 1	115	117	0.89
1 1/2	(N)ER015SD			18/3	2.4	9.1	4.5	10.2 x 1	159	172	1.6
2	(N)ER020CD			7/1	1.2	5.1	2.7	7.7 x 2	123	132	1.8
2	(N)ER020LD			14/2.5	2.4	9.1	4.5	10.2 x 1	161	174	1.6
2	(N)ER020SD			28/4.5	4.7	17.3	8.3	10.2 x 1	196	203	1.6
2 1/2	(N)ER025SD			22/3.5	4.7	17.3	8.3	11.2 x 1	218	231	1.9
3	(N)ER030LD*			17/6	4.7/1.6	19.6/9.4	9.8/4.7	12.5 x 1	300	300	2.3
3	(N)ER030CD			17/3	4.7	17.3	8.3	10.2 x 2	229	238	3.2
5	(N)ER050LD			11/2	4.7	17.3	8.3	11.2 x 2	280	293	3.8

*The (N)ER030LD listed is the previous hoist model. Refer to Harrington catalog C-EPH for features and benefits.

† Although both 208/230 & 460 Volts are shown together, the motors are NOT reconnectable.

Speed ratio is 6:1 with adjustability up to 12:1.

NER/ER Electric Chain Hoists with Hook and Lug Suspensions



NER/ER020LD
(Shown with optional canvas chain container)

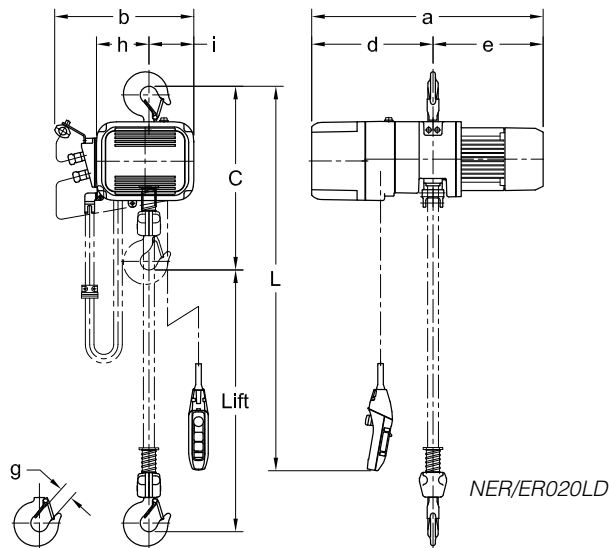

NER/ER020LD

DUAL SPEED — DIMENSIONS

Cap. (Tons)	Product Code	Headroom C (in)	a (in)		b (in)	d (in)		e (in)		g (in)	h (in)	i (in)
			NER	ER		NER	ER	NER	ER			
1/8	(N)ER001HD	13.8	21.0	22.2	13.6	10.8	12.0	10.2	10.2	1.1	3.9	4.6
1/4	(N)ER003SD	13.8	21.0	22.2	13.6	10.8	12.0	10.2	10.2	1.1	3.9	4.6
1/4	(N)ER003HD	14.6	22.3	23.3	13.7	11.8	12.8	10.5	10.5	1.1	4.4	4.2
1/2	(N)ER005LD	14.6	22.4	23.5	13.7	11.8	12.8	10.6	10.7	1.1	4.4	4.2
1/2	(N)ER005SD	14.6	22.3	23.3	13.7	11.8	12.8	10.5	10.5	1.1	4.4	4.2
1	(N)ER010LD	16.9	24.1	24.9	14.8	12.4	13.1	11.7	11.8	1.2	5.1	4.6
1	(N)ER010SD	16.9	24.5	25.2	14.8	12.4	13.1	12.1	12.1	1.2	5.1	4.6
1 1/2	(N)ER015SD	20.1	27.9	29.0	16.8	14.6	15.6	13.3	13.4	1.4	6.3	5.4
2	(N)ER020CD	27.8	24.1	24.9	14.8	12.4	13.1	11.7	11.8	1.5	7.0	2.7
2	(N)ER020LD	22.6	27.9	29.0	16.8	14.6	15.6	13.3	13.4	1.6	6.3	5.4
2	(N)ER020SD	23.2	30.2	30.8	16.8	16.2	16.8	14.0	14.0	1.6	6.3	5.4
2 1/2	(N)ER025SD	24.6	31.5	32.5	17.5	15.8	16.8	15.7	15.7	1.6	6.8	5.6
3	(N)ER030LD*	28.5	32.2	32.2	18.9	15.5	15.5	16.8	16.8	1.7	7.2	6.5
3	(N)ER030CD	30.9	30.2	30.8	16.8	16.2	16.8	14.0	14.0	1.8	8.5	3.2
5	(N)ER050LD	33.5	31.5	32.5	17.5	15.8	16.8	15.7	15.7	1.9	9.1	3.4

*The (N)ER030LD listed is the previous hoist model. Refer to Harrington catalog C-EPH for features and benefits.
Speed ratio is 6:1 with adjustability up to 12:1.



NERM/ERM Electric Chain Hoists with Motorized Trolleys



NERM/ERM020L-L/S
(Shown with optional
canvas chain container)

The MR Series of electric trolleys further expand the capabilities of our NER/ER line of electric hoists. These trolleys feature an innovative side guide roller system that results in very smooth travel along the beam.

Features and Benefits

UL® Listed**

Certified and listed to UL 1340 "Standard for Hoists."

Easy Access Suspension

External pins allow for quick change from hook to lug for trolley mount configurations on most models.

Perpendicular Orientation

MR motorized trolley mount hoists are configured as perpendicular to the beam. Parallel mount is available as an option.

Green Initiative

Built smarter without the use of harmful materials. Environmentally friendly. RoHS compliant.

Notched Hook and Latch System

Provides positive closing and improves resistance against lateral forces.

High Air Flow

Cooler motor and brake attributed to an engineered motor fin, fan blade and fan cover design.

Unique Load Sheave

Increased number of pockets reduce chain vibration and increase chain life. 5 pockets standard; 6 pockets on smaller body hoists.

Extended Chain Life

Decreased chain wear as a result of a revolutionary heat treatment process, improved material and chain size.

Limit Switches

Low-profile upper and lower limit switches are standard.

Contactors

Mechanically interlocked, heavy-duty contactors on single speed models.

Friction Clutch and Load Brake

Friction clutch is standard on NER/ER models and friction clutch with mechanical load brake standard on ER models. Carbon friction material provides consistent performance over a wide temperature range.

High Strength, Corrosion and Wear Resistant Load Chain

Grade 80, super strength, nickel-plated load chain, certified to DIN standards, uses unique technology to greatly increase resistance to fatigue and wear.

Standard Count Hour Meter

Records and displays the number of lowering starts and hoist on time which is valuable for preventive maintenance. Integral to VFD on dual speed models.

Dual Speed VFD

Under-the-cover VFD standard for dual speed hoists and trolleys. Hoist speed ratio is 6:1 with adjustability up to 12:1. Trolley speed ratio is 6:1 with adjustability up to 10:1.

"The Guardian": Smart Brake Technology

A current driven electromagnetic brake does not release unless the motor is energized. 10 year hoist brake warranty.

Pendant Controls

Ergonomic design for operator comfort. Red button emergency stop is standard on all 4-button pendants.

Standard Motorized Trolley Specifications

Capacity Range

1/8 Ton – 5 Ton
(See page 34 for 8 – 20 Ton)

Standard Voltage

208-230/460-3-60
Optional voltages available
Dual speed models are not reconnectable

Control Voltage

110V (optional 24V)

Duty Cycle*

Single Speed – 30 Min.
Dual Speed – 30/10 Min. with VFD

Classification*

ASME H4
ISO M5 or M4
FEM 2m or 1Am

Ratings

Trolley – IP55
Pendant – IP65

Standard Pendants

4-button (momentary contacts) with emergency on/off (maintained contacts)

Shafts

Standard shafts fit wide flange range
Longer shafts for wider beams
Spacers for easy adjustments

Drop Stops

Standard

Bumpers

Standard

Wheels

All steel
Shielded ball bearings
Fit flat or tapered beam flange

Standard Power Supply Length

30' (longer lengths available)

Standard Pendant Drop

Standard pendant hangs approximately 4' above the hoist's fully extended bottom hook (longer lengths available)

*See page 59 for additional information.

**Most models shipped with UL listing. Contact Customer Service for listed models.

The 3 Ton (N)ERM030L is the previous hoist model.



NERM/ERM020L-L/S
(Shown with optional
canvas chain container)

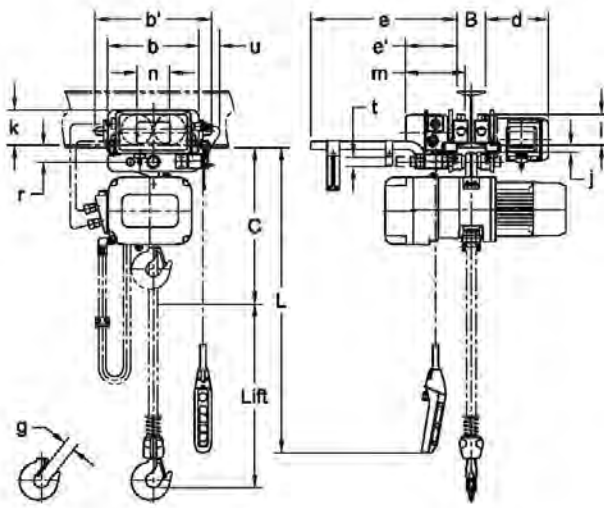

NERM/ERM020L-L/S

SINGLE SPEED HOIST WITH SINGLE SPEED TROLLEY — SPECIFICATIONS

Cap. (Tons)	Product Code	Std. Lift (ft)	Push Button Cord L (ft)	Lifting Speed (ft/min)	Traversing Speed (ft/min)	Lifting Motor 3 Phase 60 Hz			Traversing Motor 3 Phase 60 Hz			Flange Width Adjustability B (in)		Minimum Allow. Radius for Curve (in)	Load Chain Diameter (mm) x Chain Fall Lines	Net Weight (lbs)		Weight for Additional One Foot of Lift (lbs)	
						Output (Hp)	Rated Current (amps)		Output (Hp)	Rated Current (amps)		Standard	Optional			NER	ER		
1/8	(N)ERM001H-L/S	10	8.2	55	L = 40 S = 80	0.75	3.4	1.7	0.54	3.2	1.6	2.28 to 5.00	5.01 to 6.02 OR 6.03 to 12.00	31.5**	4.3 x 1	128	130	0.28	
1/4	(N)ERM003S-L/S			36		0.75	3.4	1.7	0.54	3.2	1.6				4.3 x 1	128	130	0.28	
1/4	(N)ERM003H-L/S			53		1.2	4.8	2.5	0.54	3.2	1.6				6.0 x 1	148	150	0.54	
1/2	(N)ERM005L-L/S			15		0.75	3.4	1.7	0.54	3.2	1.6				6.0 x 1	139	146	0.54	
1/2	(N)ERM005S-L/S			29		1.2	4.8	2.5	0.54	3.2	1.6				6.0 x 1	148	150	0.54	
1	(N)ERM010L-L/S			14		1.2	4.8	2.5	0.54	3.2	1.6				7.7 x 1	170	176	0.89	
1	(N)ERM010S-L/S			28		2.4	8.6	4.2	0.54	3.2	1.6	7.7 x 1	185	185	0.89				
1 1/2	(N)ERM015S-L/S			18		2.4	8.6	4.2	0.54	3.2	1.6	3.23 to 6.02	6.03 to 7.02 OR 7.03 to 12.00	31.5†	10.2 x 1	243	254	1.6	
2	(N)ERM020C-L/S			7		1.2	4.8	2.5	0.54	3.2	1.6				7.7 x 2	214	218	1.8	
2	(N)ERM020L-L/S			14		2.4	8.6	4.2	0.54	3.2	1.6				10.2 x 1	245	256	1.6	
2	(N)ERM020S-L/S			28		4.7	16.4	7.9	0.54	3.2	1.6				10.2 x 1	284	282	1.6	
2 1/2	(N)ERM025S-L/S			22		4.7	16.4	7.9	0.54	3.2	1.6				39.4	11.2 x 1	333	331	1.9
3	(N)ERM030L-L/S*			16		4.7	18.3	9.2	0.5	3.2	1.6					12.5 x 1	362	362	2.3
3	(N)ERM030C-L/S			17		4.7	16.4	7.9	0.54	3.2	1.6	10.2 x 2	340	340		3.2			
5	(N)ERM050L-L/S	9.2	11	4.7	16.4	7.9	1.0	5.1	2.5	3.94 to 7.01	7.02 to 7.60 OR 7.61 to 12.00	70.9	11.2 x 2	443	439	3.8			

*The (N)ERM030L-L/S listed is the previous hoist model. Refer to Harrington catalog C-EPH for features and benefits.

**Flange widths smaller than 4 inches will have a minimum radius of 137.8 inches.

†Flange widths smaller than 5 inches will have a minimum radius of 39.4 inches.

NERM/ERM Electric Chain Hoists with Motorized Trolleys



NERM/ERM020L-L/S
(Shown with optional
canvas chain container)

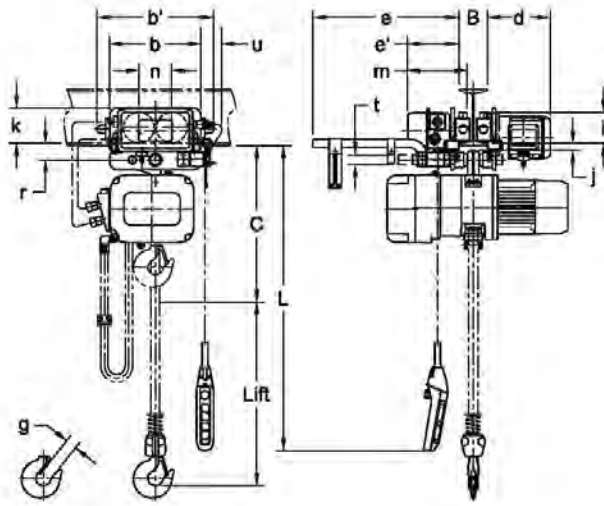

NERM/ERM020L-L/S

SINGLE SPEED HOIST WITH SINGLE SPEED TROLLEY — DIMENSIONS

Cap. (Tons)	Product Code	Headroom C (in)	b (in)	b' (in)	d (in)	e (in)	e' (in)	g (in)	i (in)	j (in)	k (in)	m (in)	n (in)	r (in)	t (in)	u (in)
1/8	(N)ERM001H-L/S	14.8	12.4	15.6	8.7	20.3	7.1	1.1	3.74	0.9	5.1	8.1	4.3	2.0	1.22	3.3
1/4	(N)ERM003S-L/S	14.8	12.4	15.6	8.7	20.3	7.1	1.1	3.74	0.9	5.1	8.1	4.3	2.0	1.22	3.3
1/4	(N)ERM003H-L/S	15.6	12.4	15.6	8.7	20.3	7.1	1.1	3.74	0.9	5.1	8.1	4.3	2.0	1.22	3.3
1/2	(N)ERM005L-L/S	15.6	12.4	15.6	8.7	20.3	7.1	1.1	3.74	0.9	5.1	8.1	4.3	2.0	1.22	3.3
1/2	(N)ERM005S-L/S	15.6	12.4	15.6	8.7	20.3	7.1	1.1	3.74	0.9	5.1	8.1	4.3	2.0	1.22	3.3
1	(N)ERM010L-L/S	17.1	12.4	15.6	8.7	20.3	7.1	1.2	3.74	0.9	5.1	8.1	4.3	2.0	1.22	3.3
1	(N)ERM010S-L/S	17.1	12.4	15.6	8.7	20.3	7.1	1.2	3.74	0.9	5.1	8.1	4.3	2.0	1.22	3.3
1 1/2	(N)ERM015S-L/S	19.9	12.8	16.4	8.8	20.5	7.3	1.4	4.33	1.1	4.9	8.3	4.6	2.4	1.42	3.0
2	(N)ERM020C-L/S	27.2	12.8	16.4	8.8	20.5	7.3	1.5	4.33	1.1	4.9	8.3	4.6	2.4	1.42	3.0
2	(N)ERM020L-L/S	22.4	12.8	16.4	8.8	20.5	7.3	1.6	4.33	1.1	4.9	8.3	4.6	2.4	1.42	3.0
2	(N)ERM020S-L/S	23.0	12.8	16.4	8.8	20.5	7.3	1.6	4.33	1.1	4.9	8.3	4.6	2.4	1.42	3.0
2 1/2	(N)ERM025S-L/S	24.4	13.4	17.4	8.9	20.5	7.3	1.6	4.92	1.1	5.2	8.5	5.2	2.7	1.69	2.8
3	(N)ERM030L-L/S*	25.4	13.4	17.4	8.9	20.5	7.3	1.7	4.92	1.1	5.2	8.5	5.2	2.7	1.69	2.7
3	(N)ERM030C-L/S	32.9	13.4	17.4	8.9	20.5	7.3	1.8	4.92	1.1	5.2	8.5	5.2	2.7	1.69	2.8
5	(N)ERM050L-L/S	33.1	15.7	19.8	11.0	20.8	7.6	1.9	5.51	1.7	5.7	9.2	5.9	3.4	2.13	2.2

*The (N)ERM030L-L/S listed is the previous hoist model. Refer to Harrington catalog C-EPH for features and benefits.



NERM/ERM020LD-L/S
(Shown with optional
canvas chain container)

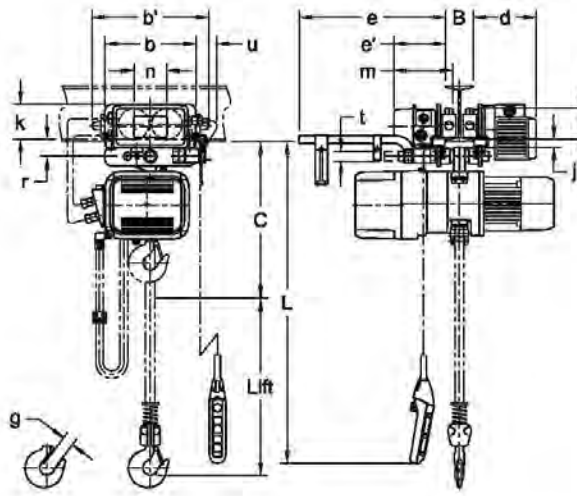

NERM/ERM020LD-L/S

DUAL SPEED HOIST WITH SINGLE SPEED TROLLEY — SPECIFICATIONS

Cap. (Tons)	Product Code	Std. Lift (ft)	Push Button Cord L (ft)	Lifting Speed (ft/min)	Traversing Speed (ft/min)	Lifting Motor† 3 Phase 60 Hz			Traversing Motor 3 Phase 60 Hz			Flange Width Adjustability B (in)		Minimum Allow. Radius for Curve (in)	Load Chain Diameter (mm) x Chain Fall Lines	Net Weight (lbs)		Weight for Additional One Foot of Lift (lbs)
						Output (Hp)	@208-230V	@460V	Output (Hp)	@208-230V	@460V	Standard	Optional			NER	ER	
1/8	(N)ERM001HD-L/S	10	8.2	55/9	L = 40 S = 80	0.75	3.6	1.8	0.54	3.2	1.6	2.28 to 5.00	5.01 to 6.02 OR 6.03 to 12.00	31.5**	4.3 x 1	128	132	0.28
1/4	(N)ERM003SD-L/S			36/6		0.75	3.6	1.8	0.54	3.2	1.6				4.3 x 1	128	132	0.28
1/4	(N)ERM003HD-L/S			53/9		1.2	5.1	2.7	0.54	3.2	1.6				6.0 x 1	146	150	0.54
1/2	(N)ERM005LD-L/S			15/2.5		0.75	3.6	1.8	0.54	3.2	1.6				6.0 x 1	137	146	0.54
1/2	(N)ERM005SD-L/S			29/5		1.2	5.1	2.7	0.54	3.2	1.6				6.0 x 1	146	150	0.54
1	(N)ERM010LD-L/S			14/2.5		1.2	5.1	2.7	0.54	3.2	1.6				7.7 x 1	166	174	0.89
1	(N)ERM010SD-L/S			28/4.5		2.4	9.1	4.5	0.54	3.2	1.6	7.7 x 1	181	183	0.89			
1 1/2	(N)ERM015SD-L/S			18/3		2.4	9.1	4.5	0.54	3.2	1.6	3.23 to 6.02	6.03 to 7.02 OR 7.03 to 12.00	31.5†	10.2 x 1	243	256	1.6
2	(N)ERM020CD-L/S			7/1		1.2	5.1	2.7	0.54	3.2	1.6				7.7 x 2	207	216	1.8
2	(N)ERM020LD-L/S			14/2.5		2.4	9.1	4.5	0.54	3.2	1.6				10.2 x 1	245	256	1.6
2	(N)ERM020SD-L/S			28/4.5		4.7	17.3	8.3	0.54	3.2	1.6				10.2 x 1	280	286	1.6
2 1/2	(N)ERM025SD-L/S			22/3.5		4.7	17.3	8.3	0.54	3.2	1.6				11.2 x 1	324	338	1.9
3	(N)ERM030LD-L/S*			17/6		4.7/1.6	19.6/9.4	9.8/4.7	0.5	3.2	1.6				12.5 x 1	406	406	2.3
3	(N)ERM030CD-L/S			17/3		4.7	17.3	8.3	0.54	3.2	1.6	10.2 x 2	336	344	3.2			
5	(N)ERM050LD-L/S	9.2	11/2	4.7	17.3	8.3	1.0	5.1	2.5	3.94 to 7.01	7.02 to 7.60 OR 7.61 to 12.00	70.9	11.2 x 2	434	448	3.8		

*The (N)ERM030LD-L/S listed is the previous hoist model. Refer to Harrington catalog C-EPH for features and benefits.

**Flange widths smaller than 4 inches will have a minimum radius of 137.8 inches.

†Flange widths smaller than 5 inches will have a minimum radius of 39.4 inches.

‡Although both 208/230 & 460 Volts are shown together, the motors are NOT reconnectable.

Speed ratio is 6:1 with adjustability up to 12:1.

NERM/ERM Electric Chain Hoists with Motorized Trolleys



NERM/ERM020LD-L/S
(Shown with optional
canvas chain container)

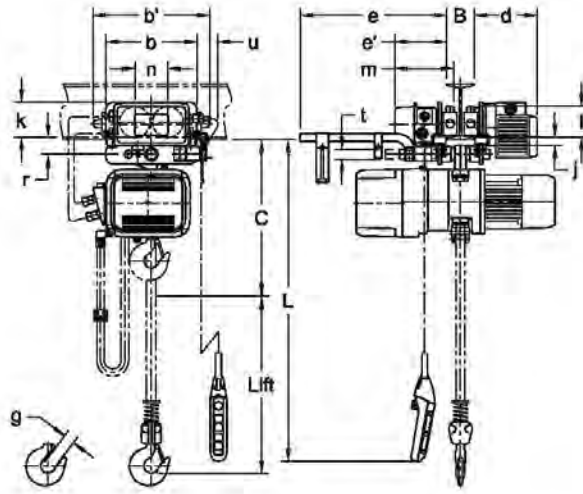

NERM/ERM020LD-L/S

DUAL SPEED HOIST WITH SINGLE SPEED TROLLEY — DIMENSIONS

Cap. (Tons)	Product Code	Headroom C (in)	b (in)	b' (in)	d (in)	e (in)	e' (in)	g (in)	i (in)	j (in)	k (in)	m (in)	n (in)	r (in)	t (in)	u (in)
1/8	(N)ERM001HD-L/S	14.8	12.4	15.6	8.7	20.3	7.1	1.1	3.74	0.9	5.1	8.1	4.3	2.0	1.22	3.3
1/4	(N)ERM003SD-L/S	14.8	12.4	15.6	8.7	20.3	7.1	1.1	3.74	0.9	5.1	8.1	4.3	2.0	1.22	3.3
1/4	(N)ERM003HD-L/S	15.6	12.4	15.6	8.7	20.3	7.1	1.1	3.74	0.9	5.1	8.1	4.3	2.0	1.22	3.3
1/2	(N)ERM005LD-L/S	15.6	12.4	15.6	8.7	20.3	7.1	1.1	3.74	0.9	5.1	8.1	4.3	2.0	1.22	3.3
1/2	(N)ERM005SD-L/S	15.6	12.4	15.6	8.7	20.3	7.1	1.1	3.74	0.9	5.1	8.1	4.3	2.0	1.22	3.3
1	(N)ERM010LD-L/S	17.1	12.4	15.6	8.7	20.3	7.1	1.2	3.74	0.9	5.1	8.1	4.3	2.0	1.22	3.3
1	(N)ERM010SD-L/S	17.1	12.4	15.6	8.7	20.3	7.1	1.2	3.74	0.9	5.1	8.1	4.3	2.0	1.22	3.3
1 1/2	(N)ERM015SD-L/S	19.9	12.8	16.4	8.8	20.5	7.3	1.4	4.33	1.1	4.9	8.3	4.6	2.4	1.42	3.0
2	(N)ERM020CD-L/S	27.2	12.8	16.4	8.8	20.5	7.3	1.5	4.33	1.1	4.9	8.3	4.6	2.4	1.42	3.0
2	(N)ERM020LD-L/S	22.4	12.8	16.4	8.8	20.5	7.3	1.6	4.33	1.1	4.9	8.3	4.6	2.4	1.42	3.0
2	(N)ERM020SD-L/S	23.0	12.8	16.4	8.8	20.5	7.3	1.6	4.33	1.1	4.9	8.3	4.6	2.4	1.42	3.0
2 1/2	(N)ERM025SD-L/S	24.4	13.4	17.4	8.9	20.5	7.3	1.6	4.92	1.1	5.2	8.5	5.2	2.7	1.69	2.8
3	(N)ERM030LD-L/S*	28.0	13.4	17.4	8.9	20.5	7.3	1.7	4.92	1.1	5.2	8.5	5.2	2.7	1.69	2.7
3	(N)ERM030CD-L/S	32.9	13.4	17.4	8.9	20.5	7.3	1.8	4.92	1.1	5.2	8.5	5.2	2.7	1.69	2.8
5	(N)ERM050LD-L/S	33.1	15.7	19.8	11.0	20.8	7.6	1.9	5.51	1.7	5.7	9.2	5.9	3.4	2.13	2.2

*The (N)ERM030LD-L/S listed is the previous hoist model. Refer to Harrington catalog C-EPH for features and benefits.
Speed ratio is 6:1 with adjustability up to 12:1.



NERM/ERM020LD-SD
(Shown with optional
canvas chain container)

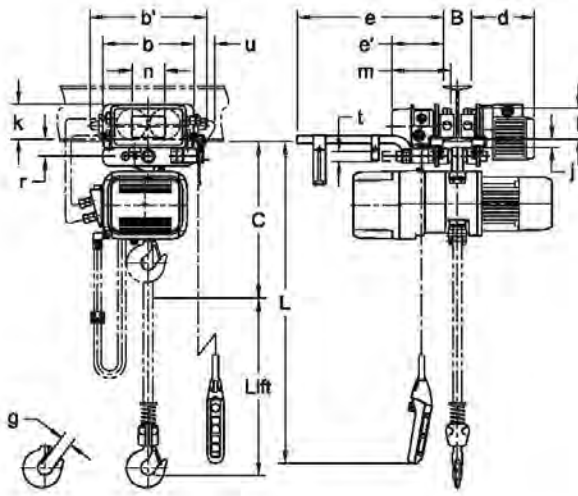

NERM/ERM020LD-SD

DUAL SPEED HOIST WITH DUAL SPEED TROLLEY — SPECIFICATIONS

Cap. (Tons)	Product Code	Std. Lift (ft)	Push Button Cord L (ft)	Lifting Speed (ft/min)	Traversing Speed (ft/min)	Lifting Motor† 3 Phase 60 Hz			Traversing Motor† 3 Phase 60 Hz			Flange Width Adjustability B (in)		Minimum Allow. Radius for Curve (in)	Load Chain Diameter (mm) x Chain Fall Lines	Net Weight (lbs)		Weight for Additional One Foot of Lift (lbs)	
						Output (Hp)	Rated Current (amps)		Output (Hp)	Rated Current (amps)		Standard	Optional			NER	ER		
1/8	(N)ERM001HD-SD	10	8.2	55/9	80/13	0.75	3.6	1.8	0.54	3.4	1.7	2.28 to 5.00	5.01 to 6.02 OR 6.03 to 12.00	31.5**	4.3 x 1	130	135	0.28	
1/4	(N)ERM003SD-SD			36/6		0.75	3.6	1.8	0.54	3.4	1.7				4.3 x 1	130	135	0.28	
1/4	(N)ERM003HD-SD			53/9		1.2	5.1	2.7	0.54	3.4	1.7				6.0 x 1	150	154	0.54	
1/2	(N)ERM005LD-SD			15/2.5		0.75	3.6	1.8	0.54	3.4	1.7				6.0 x 1	141	150	0.54	
1/2	(N)ERM005SD-SD			29/5		1.2	5.1	2.7	0.54	3.4	1.7				6.0 x 1	150	154	0.54	
1	(N)ERM010LD-SD			14/2.5		1.2	5.1	2.7	0.54	3.4	1.7				7.7 x 1	170	179	0.89	
1	(N)ERM010SD-SD			28/4.5		2.4	9.1	4.5	0.54	3.4	1.7	7.7 x 1	185	187	0.89				
1 1/2	(N)ERM015SD-SD			18/3		2.4	9.1	4.5	0.54	3.4	1.7	3.23 to 6.02	6.03 to 7.02 OR 7.03 to 12.00	31.5†	10.2 x 1	245	260	1.6	
2	(N)ERM020CD-SD			7/1		1.2	5.1	2.7	0.54	3.4	1.7				7.7 x 2	214	223	1.8	
2	(N)ERM020LD-SD			14/2.5		2.4	9.1	4.5	0.54	3.4	1.7				10.2 x 1	247	262	1.6	
2	(N)ERM020SD-SD			28/4.5		4.7	17.3	8.3	0.54	3.4	1.7				10.2 x 1	284	291	1.6	
2 1/2	(N)ERM025SD-SD			22/3.5		4.7	17.3	8.3	0.54	3.4	1.7				39.4	11.2 x 1	331	344	1.9
3	(N)ERM030LD-SD*			17/6		4.7/1.6	19.6/9.4	9.8/4.7	0.9/0.2	3.6/3.1	1.8/1.6					12.5 x 1	412	412	2.3
3	(N)ERM030CD-SD			17/3		4.7	17.3	8.3	0.54	3.4	1.7	10.2 x 2	340	351	3.2				
5	(N)ERM050LD-SD	9.2	11/2	4.7	17.3	8.3	1.0	5.4	2.7	3.94 to 7.01	7.02 to 7.60 OR 7.61 to 12.00	70.9	11.2 x 2	439	452	3.8			

*The (N)ERM030LD-SD listed is the previous hoist model. Refer to Harrington catalog C-EPH for features and benefits.

**Flange widths smaller than 4 inches will have a minimum radius of 137.8 inches.

†Flange widths smaller than 5 inches will have a minimum radius of 39.4 inches.

*Although both 208/230 & 460 Volts are shown together, the motors are NOT reconnectable.

Hoist speed ratio is 6:1 with adjustability up to 12:1.

Trolley speed ratio is 6:1 with adjustability up to 10:1.

NERM/ERM Electric Chain Hoists with Motorized Trolleys



NERM/ERM020LD-SD
(Shown with optional
canvas chain container)

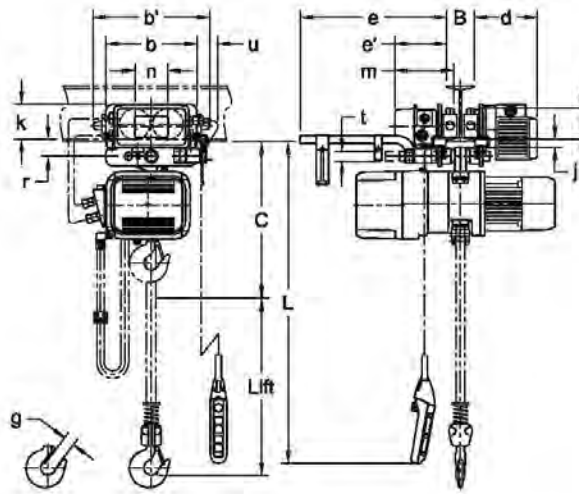

NERM/ERM020LD-SD

DUAL SPEED HOIST WITH DUAL SPEED TROLLEY — DIMENSIONS

Cap. (Tons)	Product Code	Headroom C (in)	b (in)	b' (in)	d (in)	e (in)	e' (in)	g (in)	i (in)	j (in)	k (in)	m (in)	n (in)	r (in)	t (in)	u (in)
1/8	(N)ERM001HD-SD	14.8	12.4	15.6	8.7	20.3	7.1	1.1	3.74	0.9	5.1	8.1	4.3	2.0	1.22	3.3
1/4	(N)ERM003SD-SD	14.8	12.4	15.6	8.7	20.3	7.1	1.1	3.74	0.9	5.1	8.1	4.3	2.0	1.22	3.3
1/4	(N)ERM003HD-SD	15.6	12.4	15.6	8.7	20.3	7.1	1.1	3.74	0.9	5.1	8.1	4.3	2.0	1.22	3.3
1/2	(N)ERM005LD-SD	15.6	12.4	15.6	8.7	20.3	7.1	1.1	3.74	0.9	5.1	8.1	4.3	2.0	1.22	3.3
1/2	(N)ERM005SD-SD	15.6	12.4	15.6	8.7	20.3	7.1	1.1	3.74	0.9	5.1	8.1	4.3	2.0	1.22	3.3
1	(N)ERM010LD-SD	17.1	12.4	15.6	8.7	20.3	7.1	1.2	3.74	0.9	5.1	8.1	4.3	2.0	1.22	3.3
1	(N)ERM010SD-SD	17.1	12.4	15.6	8.7	20.3	7.1	1.2	3.74	0.9	5.1	8.1	4.3	2.0	1.22	3.3
1 1/2	(N)ERM015SD-SD	19.9	12.8	16.4	8.8	20.5	7.3	1.4	4.33	1.1	4.9	8.3	4.6	2.4	1.42	3.0
2	(N)ERM020CD-SD	27.2	12.8	16.4	8.8	20.5	7.3	1.5	4.33	1.1	4.9	8.3	4.6	2.4	1.42	3.0
2	(N)ERM020LD-SD	22.4	12.8	16.4	8.8	20.5	7.3	1.6	4.33	1.1	4.9	8.3	4.6	2.4	1.42	3.0
2	(N)ERM020SD-SD	23.0	12.8	16.4	8.8	20.5	7.3	1.6	4.33	1.1	4.9	8.3	4.6	2.4	1.42	3.0
2 1/2	(N)ERM025SD-SD	24.4	13.4	17.4	8.9	20.5	7.3	1.6	4.92	1.1	5.2	8.5	5.2	2.7	1.69	2.8
3	(N)ERM030LD-SD*	28.0	13.4	17.4	10.8	20.5	7.3	1.7	4.92	1.1	5.2	8.5	5.2	2.7	1.69	2.7
3	(N)ERM030CD-SD	32.9	13.4	17.4	8.9	20.5	7.3	1.8	4.92	1.1	5.2	8.5	5.2	2.7	1.69	2.8
5	(N)ERM050LD-SD	33.1	15.7	19.8	11.0	20.8	7.6	1.9	5.51	1.7	5.7	9.2	5.9	3.4	2.13	2.2

*The (N)ERM030LD-SD listed is the previous hoist model. Refer to Harrington catalog C-EPH for features and benefits.

Hoist speed ratio is 6:1 with adjustability up to 12:1.

Trolley speed ratio is 6:1 with adjustability up to 10:1.

MR Motorized Trolleys

Pull-Rotor Motor Brake

Extremely durable and reliable, this advanced design furnishes precision load control, deceleration and long life.

Heavy-Duty Motor

Designed for top performance with high-horsepower, 30-minute duty rating, cooling fins and standard thermal motor protection. Motor is totally enclosed, non-ventilated (TENV).

Variable Frequency Drive

Dual speed controls via “under-the-cover” variable frequency drive standard.

Sealed Protection

Appropriate for both indoor and outdoor applications, including harsh environments. (Consult owner’s manuals for details.) Gaskets throughout the trolley provide for an IP55 rating.

Built-In Drop Stops

Important feature provides additional security for the operator and the equipment.

Rubber Bumpers

Standard feature on all motorized trolleys. Provides protection from collisions. Complies with ASME standards.

Side Guide Rollers

Four ball bearing supported rollers enhance smooth trolley motion and reduce wear of the wheels and beam.

Cable Support Arm Assembly

Convenient “tow bar” is standard component that gives support and guides the power supply festooning.

Pendant Plug-In Connections

Saves valuable time on setup and maintenance. “Quick disconnect” replaces typical competitive hard-wired designs.

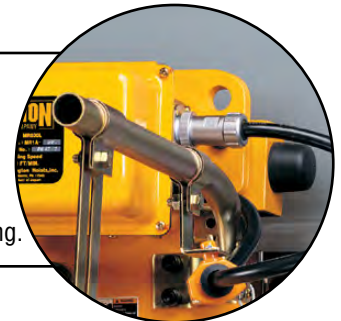
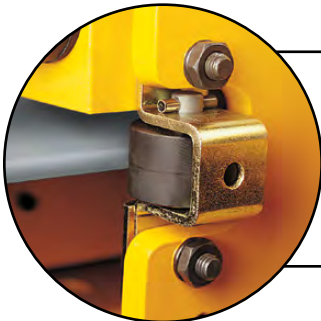
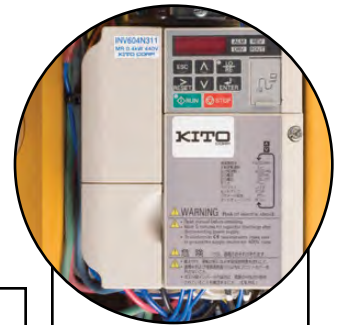
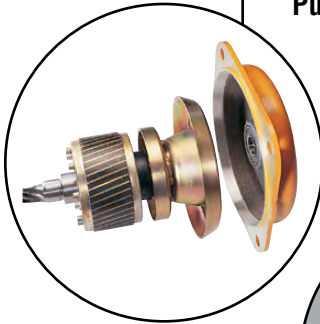

NERP/ERP and NERG/ERG Electric Chain Hoists with Push or Geared Trolleys



NERP/ERP010S
(Shown with optional canvas chain container and rubber bumpers)

Mounting our NER/ER Series hoists to either a PT push or GT geared trolley will create an easy and economical method of transporting the load. This combination is ideal for small workshops and infrequent moves.

Features and Benefits

UL® Listed**

Certified and listed to UL 1340 "Standard for Hoists."

Easy Access Suspension

External pins allow for quick change from hook to lug for trolley mount configurations on most models.

Perpendicular Orientation

PT push trolley mount hoists are configured as perpendicular to the beam. Parallel mount is available as an option. Note 020C and 030C models are parallel mount as standard.

Green Initiative

Built smarter without the use of harmful materials. Environmentally friendly. RoHS compliant.

Notched Hook and Latch System

Provides positive closing and improves resistance against lateral forces.

High Air Flow

Cooler motor and brake attributed to an engineered motor fin, fan blade and fan cover design.

Unique Load Sheave

Increased number of pockets reduce chain vibration and increase chain life. 5 pockets standard; 6 pockets on smaller body hoists.

Extended Chain Life

Decreased chain wear as a result of a revolutionary heat treatment process, improved material and chain size.

Limit Switches

Low-profile upper and lower limit switches are standard.

Contactors

Mechanically interlocked, heavy-duty contactors on single speed models.

Friction Clutch and Load Brake

Friction clutch is standard on NER/ER models and friction clutch with mechanical load brake standard on ER models. Carbon friction material provides consistent performance over a wide temperature range.

High Strength, Corrosion and Wear Resistant Load Chain

Grade 80, super strength, nickel-plated load chain, certified to DIN standards, uses unique technology to greatly increase resistance to fatigue and wear.

Standard Count Hour Meter

Records and displays the number of lowering starts and hoist on time which is valuable for preventive maintenance. Integral to VFD on dual speed models.

Dual Speed VFD

Under-the-cover VFD standard for dual speed hoists. Speed ratio is 6:1 with adjustability up to 12:1.

"The Guardian": Smart Brake Technology

A current driven electromagnetic brake does not release unless the motor is energized. 10 year hoist brake warranty.

Pendant Controls

Ergonomic design for operator comfort. Red button emergency stop is standard on all 2-button dual speed pendants.

Standard Trolley Specifications

Capacity Range

PT Push – 1/8 Ton – 5 Ton
GT Geared – 1/8 – 5 Ton
(See page 38 for 8 – 20 Ton)

Shafts

Standard shafts fit wide range
Longer shafts for wider beams
Spacers for easy adjustments

Drop Stops

Standard

Bumpers

Optional

Standard Hand Chain Drop

Standard geared trolley hand chain hangs approximately 2' less than hoist's fully extended bottom hook (longer drops available)

Wheels

All steel
Sealed ball bearings
Fit flat or tapered beam flange

Standard Hoist Pendant Drop

Standard pendant hangs approximately 4' above the hoist's fully extended bottom hook (longer lengths available)

Standard Hoist Power Supply Length

15' (longer lengths available)

Standard Pendants

Single speed: 2-button (momentary contacts)
Dual speed: 2-button (momentary contacts) with emergency On/Off (maintained contacts)

** Most models shipped with UL listing. Contact Customer Service for listed models.
The 3 Ton (N)ERP030L and (N)ERG030L are the previous hoist models.



NERP/ERP010S
(Shown with optional
canvas chain container
and rubber bumpers)

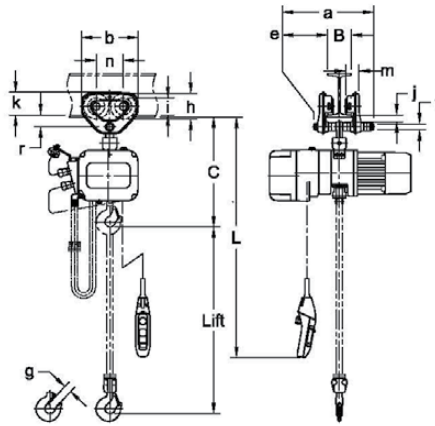

NERP/ERP010S

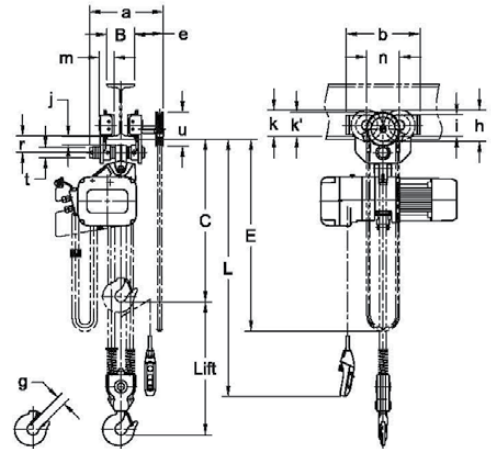

NERG/ERG050L

SINGLE SPEED HOIST WITH PUSH OR GEARED TROLLEY — SPECIFICATIONS

Cap. (Tons)	Product Code	Std. Lift (ft)	Push Button Cord L (ft)	Lifting Speed (ft/min)	Lifting Motor 3 Phase 60 Hz			Flange Width Adjustability B (in)		Min.** Allow. Radius for Curve (in)	Load Chain Diameter (mm) x Chain Fall Lines	Net Weight (lbs)		Weight for Additional One Foot of Lift (lbs)
					Output (Hp)	Rated Current @208-230V	Rated Current @460V	Standard	Optional			NER	ER	
1/8	(N)ERP(ERG)001H	10	8.2	55	0.75	3.4	1.7	2.28 to 4.00 (2.28 to 5.00)	4.01 to 8.00 (5.01 to 8.00) OR 8.01 to 12.00	43.3 (51.2)	4.3 x 1	71 (88)	73 (90)	0.28 (.94)
1/4	(N)ERP(ERG)003S			36	0.75	3.4	1.7				6.0 x 1	90 (108)	93 (110)	0.54 (1.1)
1/4	(N)ERP(ERG)003H			53	1.2	4.8	2.5							
1/2	(N)ERP(ERG)005L			15	0.75	3.4	1.7				6.0 x 1	90 (108)	93 (110)	0.54 (1.1)
1/2	(N)ERP(ERG)005S			29	1.2	4.8	2.5	7.7 x 1	121 (130)	128 (137)				
1	(N)ERP(ERG)010L			14	1.2	4.8	2.5				7.7 x 1	137 (146)	137 (146)	0.89 (1.6)
1	(N)ERP(ERG)010S			28	2.4	8.6	4.2	10.2 x 1	187 (196)	201 (209)				
1 1/2	(N)ERP(ERG)015S			18	2.4	8.6	4.2				7.7 x 2	161 (172)	165 (176)	1.8 (2.4)
2	(N)ERP(ERG)020C			7	1.2	4.8	2.5	10.2 x 1	190 (198)	203 (212)				
2	(N)ERP(ERG)020L			14	2.4	8.6	4.2				10.2 x 1	231 (240)	229 (238)	1.6 (2.2)
2	(N)ERP(ERG)020S	28	4.7	16.4	7.9	11.2 x 1	280 (289)	278 (287)	1.9 (2.5)					
2 1/2	(N)ERP(ERG)025S	22	4.7	16.4	7.9					12.5 x 1	311 (322)	311 (322)	2.3 (2.9)	
3	(N)ERP(ERG)030L*	16	4.7	18.3	9.2	10.2 x 2	284 (293)	282 (291)	3.2 (3.8)					
3	(N)ERP(ERG)030C	17	4.7	16.4	7.9					11.2 x 2	399 (415)	395 (410)	3.8 (4.4)	
5	(N)ERP(ERG)050L	11	4.7	16.4	7.9	3.94 to 7.02	7.03 to 12.00	90.6						

Figures in parentheses are data for geared trolley.

*The (N)ERP(ERG)030L listed are the previous hoist models. Refer to Harrington catalog C-EPH for features and benefits.

**Minimum Flange Width for curved beam: 1 Ton Push and 1/8 to 1 Ton Geared = 2.87 in.
3 Ton Push or Geared = 3.50 in

NERP/ERP and NERG/ERG Electric Chain Hoists with Push or Geared Trolleys



NERP/ERP010S
(Shown with optional canvas chain container and rubber bumpers)

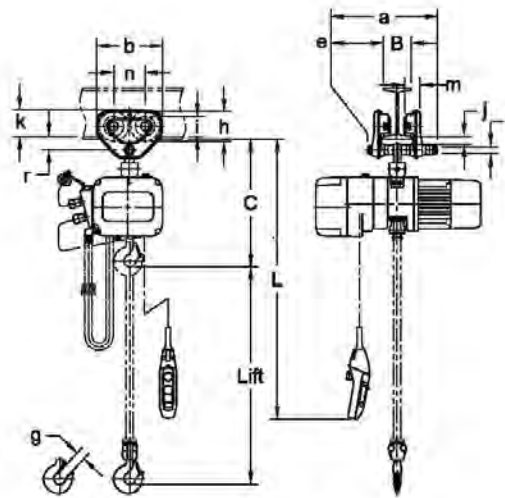

NERP/ERP010S

SINGLE SPEED HOIST WITH PUSH TROLLEY — DIMENSIONS

Cap. (Tons)	Product Code	Headroom C (in)	a (in)	b (in)	e (in)	g (in)	h (in)	i (in)	j (in)	k (in)	m (in)	n (in)	r (in)	t (in)
1/8	(N)ERP001H	15.6	8.0	7.2	1.8	1.1	3.2	2.36	0.8	3.0	1.9	3.3	1.5	0.87
1/4	(N)ERP003S	15.6	8.0	7.2	1.8	1.1	3.2	2.36	0.8	3.0	1.9	3.3	1.5	0.87
1/4	(N)ERP003H	16.3	8.0	7.2	1.8	1.1	3.2	2.36	0.8	3.0	1.9	3.3	1.5	0.87
1/2	(N)ERP005L	16.3	8.0	7.2	1.8	1.1	3.2	2.36	0.8	3.0	1.9	3.3	1.5	0.87
1/2	(N)ERP005S	16.3	8.0	7.2	1.8	1.1	3.2	2.36	0.8	3.0	1.9	3.3	1.5	0.87
1	(N)ERP010L	18.5	9.8	9.3	2.2	1.2	4.2	2.80	1.1	3.7	2.2	4.4	2.0	0.98
1	(N)ERP010S	18.5	9.8	9.3	2.2	1.2	4.2	2.80	1.1	3.7	2.2	4.4	2.0	0.98
1 1/2	(N)ERP015S	22.4	11.8	11.0	2.7	1.4	5.0	3.35	1.4	4.4	2.8	5.2	2.4	1.26
2	(N)ERP020C	27.4	11.8	11.0	2.7	1.5	5.0	3.35	1.4	4.4	2.8	5.2	2.4	1.26
2	(N)ERP020L	25.0	11.8	11.0	2.7	1.6	5.0	3.35	1.4	4.4	2.8	5.2	2.4	1.26
2	(N)ERP020S	25.6	11.8	11.0	2.7	1.6	5.0	3.35	1.4	4.4	2.8	5.2	2.4	1.26
2 1/2	(N)ERP025S	26.8	12.6	12.8	3.1	1.6	5.8	3.94	1.4	5.3	3.1	6.0	2.7	1.42
3	(N)ERP030L*	27.8	12.6	12.8	3.1	1.7	5.8	3.94	1.4	5.3	3.1	6.0	2.7	1.42
3	(N)ERP030C	32.7	12.6	12.8	3.1	1.8	5.8	3.94	1.4	5.3	3.1	6.0	2.7	1.42
5	(N)ERP050L	33.1	11.7	15.7	2.1	1.9	6.7	4.65	1.8	5.6	3.2	7.0	3.4	2.13

*The (N)ERP030L listed is the previous hoist model. Refer to Harrington catalog C-EPH for features and benefits.



NERG/ERG050L

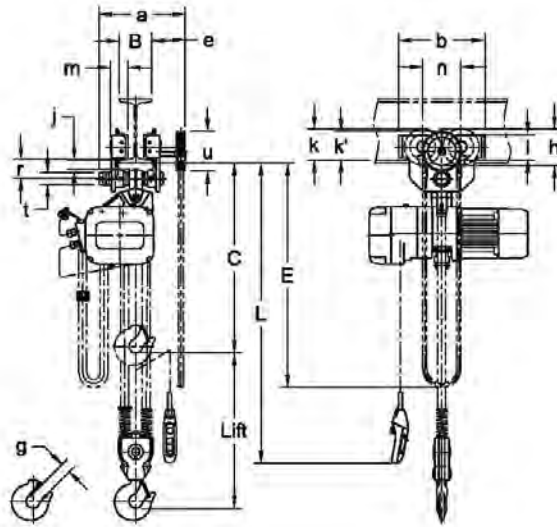

NERG/ERG050L

SINGLE SPEED HOIST WITH GEARED TROLLEY — DIMENSIONS

Cap. (Tons)	Product Code	Headroom C (in)	E (ft)	a (in)	b (in)	e (in)	g (in)	h (in)	i (in)	j (in)	k (in)	k' (in)	m (in)	n (in)	r (in)	t (in)	u (in)
1/8	(N)ERG001H	16.3	10.5	13.6	9.3	6.0	1.1	4.2	2.80	1.1	3.7	4.2	2.2	4.4	1.9	0.98	7.2
1/4	(N)ERG003S	16.3	10.5	13.6	9.3	6.0	1.1	4.2	2.80	1.1	3.7	4.2	2.2	4.4	1.9	0.98	7.2
1/4	(N)ERG003H	17.1	10.5	13.6	9.3	6.0	1.1	4.2	2.80	1.1	3.7	4.2	2.2	4.4	1.9	0.98	7.2
1/2	(N)ERG005L	17.1	10.5	13.6	9.3	6.0	1.1	4.2	2.80	1.1	3.7	4.2	2.2	4.4	1.9	0.98	7.2
1/2	(N)ERG005S	17.1	10.5	13.6	9.3	6.0	1.1	4.2	2.80	1.1	3.7	4.2	2.2	4.4	1.9	0.98	7.2
1	(N)ERG010L	18.5	10.5	13.6	9.3	6.0	1.2	4.2	2.80	1.1	3.7	4.2	2.2	4.4	1.9	0.98	7.2
1	(N)ERG010S	18.5	10.5	13.6	9.3	6.0	1.2	4.2	2.80	1.1	3.7	4.2	2.2	4.4	1.9	0.98	7.2
1 1/2	(N)ERG015S	22.4	10.5	15.2	11.0	6.1	1.4	5.0	3.35	1.4	4.4	4.3	2.8	5.2	2.4	1.26	7.2
2	(N)ERG020C	27.0	10.5	15.2	11.0	6.1	1.5	5.0	3.35	1.4	4.4	4.3	2.8	5.2	2.4	1.26	7.2
2	(N)ERG020L	25.0	10.5	15.2	11.0	6.1	1.6	5.0	3.35	1.4	4.4	4.3	2.8	5.2	2.4	1.26	7.2
2	(N)ERG020S	25.6	10.5	15.2	11.0	6.1	1.6	5.0	3.35	1.4	4.4	4.3	2.8	5.2	2.4	1.26	7.2
2 1/2	(N)ERG025S	26.8	11.0	15.7	12.8	6.2	1.6	5.8	3.94	1.4	5.3	4.5	3.1	6.0	2.7	1.42	7.2
3	(N)ERG030L*	27.8	11.0	15.7	12.8	6.2	1.7	5.8	3.94	1.4	5.3	4.5	3.1	6.0	2.7	1.42	7.2
3	(N)ERG030C	32.7	11.0	15.7	12.8	6.2	1.8	5.8	3.94	1.4	5.3	4.5	3.1	6.0	2.7	1.42	7.2
5	(N)ERG050L	33.1	11.5	15.8	15.7	6.2	1.9	6.7	4.65	1.8	5.6	5.1	3.2	7.0	3.4	2.13	7.2

*The (N)ERG030L listed is the previous hoist model. Refer to Harrington catalog C-EPH for features and benefits.

NERP/ERP and NERG/ERG Electric Chain Hoists with Push or Geared Trolleys

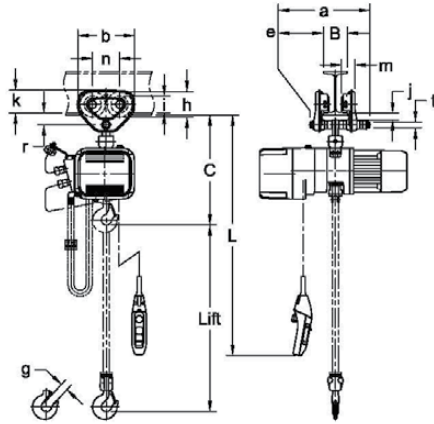

NERP/ERP010SD

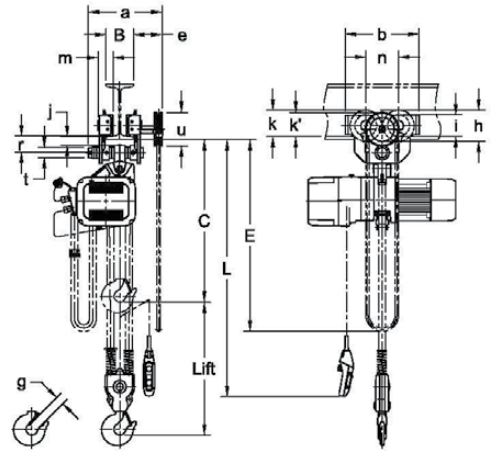

NERG/ERG050LD

NERP/ERP010SD
(Shown with optional canvas chain container and rubber bumpers)

DUAL SPEED HOIST WITH PUSH OR GEARED TROLLEY — SPECIFICATIONS

Cap. (Tons)	Product Code	Std. Lift (ft)	Push Button Cord L (ft)	Lifting Speed (ft/min)	Lifting Motor 3 Phase 60 Hz			Flange Width Adjustability B (in)		Min** Allow. Radius for Curve (in)	Load Chain Diameter (mm) x Chain Fall Lines	Net Weight (lbs)		Weight for Additional One Foot of Lift (lbs)		
					Output (Hp)	Rated Current @208V	Rated Current @460V	Standard	Optional			NER	ER			
1/8	(N)ERP(ERG)001HD	10	8.2	55/9	0.75	3.6	1.8	2.28 to 4.00 (2.28 to 5.00)	4.01 to 8.00 (5.01 to 8.00) OR 8.01 to 12.00	43.3 (51.2)	4.3 x 1	71 (88)	75 (92)	0.28 (.94)		
1/4	(N)ERP(ERG)003SD			36/6	0.75	3.6	1.8				4.3 x 1	71 (88)	75 (92)	0.28 (.94)		
1/4	(N)ERP(ERG)003HD			53/9	1.2	5.1	2.7				6.0 x 1	88 (106)	93 (110)	0.54 (1.1)		
1/2	(N)ERP(ERG)005LD			15/2.5	0.75	3.6	1.8				6.0 x 1	80 (97)	90 (106)	0.54 (1.1)		
1/2	(N)ERP(ERG)005SD			29/5	1.2	5.1	2.7	6.0 x 1	88 (106)	93 (110)	0.54 (1.1)					
1	(N)ERP(ERG)010LD			14/2.5	1.2	5.1	2.7	2.28 to 5.00	5.01 to 8.00 OR 8.01 to 12.00	51.2	7.7 x 1	117 (126)	126 (135)	0.89 (1.6)		
1	(N)ERP(ERG)010SD			28/4.5	2.4	9.1	4.5				7.7 x 1	132 (141)	135 (143)	0.89 (1.6)		
1 1/2	(N)ERP(ERG)015SD			9.2	9.2	18/3	2.4	9.1	4.5	3.23 to 6.02	6.03 to 12.00	59.1	10.2 x 1	187 (196)	203 (212)	1.6 (2.2)
2	(N)ERP(ERG)020CD					7/1	1.2	5.1	2.7				7.7 x 2	154 (165)	163 (174)	1.8 (2.4)
2	(N)ERP(ERG)020LD					14/2.5	2.4	9.1	4.5				10.2 x 1	190 (198)	203 (212)	1.6 (2.2)
2	(N)ERP(ERG)020SD	28/4.5	4.7			17.3	8.3	10.2 x 1	227 (236)				234 (243)	1.6 (2.2)		
2 1/2	(N)ERP(ERG)025SD	22/3.5	4.7			17.3	8.3	66.9	11.2 x 1	271 (280)	284 (293)	1.9 (2.5)				
3	(N)ERP(ERG)030LD*	17/6	4.7/1.6			19.6/9.4	9.8/4.7		12.5 x 1	355 (366)	355 (366)	2.3 (2.9)				
3	(N)ERP(ERG)030CD	17/3	4.7			17.3	8.3		10.2 x 2	280 (289)	287 (295)	3.2 (3.8)				
5	(N)ERP(ERG)050LD	11/2	4.7			17.3	8.3	3.94 to 7.02	7.03 to 12.00	90.6	11.2 x 2	390 (406)	404 (419)	3.8 (4.4)		

Figures in parentheses are data for geared trolley.

*The (N)ERP(ERG)030LD listed are the previous hoist models. Refer to Harrington catalog C-EPH for features and benefits.

**Minimum Flange Width for curved beam: 1 Ton Push and 1/8 to 1 Ton Geared = 2.87 in.

3 Ton Push or Geared = 3.50 in

Speed ratio is 6:1 with adjustability up to 12:1.

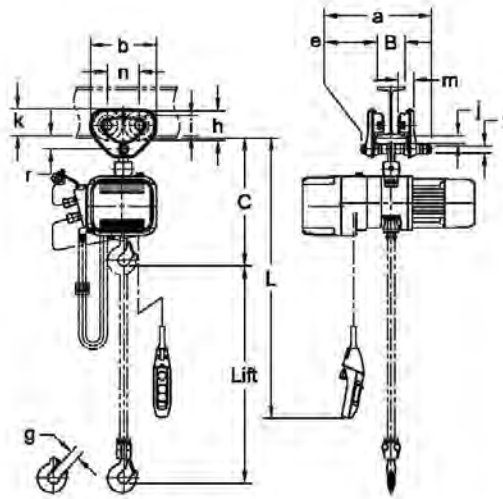

NERP/ERP010SD

NERP/ERP010SD
(Shown with optional
canvas chain container and
rubber bumpers)

DUAL SPEED HOIST WITH PUSH TROLLEY — DIMENSIONS

Cap. (Tons)	Product Code	Headroom C (in)	a (in)	b (in)	e (in)	g (in)	h (in)	i (in)	j (in)	k (in)	m (in)	n (in)	r (in)	t (in)
1/8	(N)ERP001HD	15.6	8.0	7.2	1.8	1.1	3.2	2.36	0.8	3.0	1.9	3.3	1.5	0.87
1/4	(N)ERP003SD	15.6	8.0	7.2	1.8	1.1	3.2	2.36	0.8	3.0	1.9	3.3	1.5	0.87
1/4	(N)ERP003HD	16.3	8.0	7.2	1.8	1.1	3.2	2.36	0.8	3.0	1.9	3.3	1.5	0.87
1/2	(N)ERP005LD	16.3	8.0	7.2	1.8	1.1	3.2	2.36	0.8	3.0	1.9	3.3	1.5	0.87
1/2	(N)ERP005SD	16.3	8.0	7.2	1.8	1.1	3.2	2.36	0.8	3.0	1.9	3.3	1.5	0.87
1	(N)ERP010LD	18.5	9.8	9.3	2.2	1.2	4.2	2.80	1.1	3.7	2.2	4.4	2.0	0.98
1	(N)ERP010SD	18.5	9.8	9.3	2.2	1.2	4.2	2.80	1.1	3.7	2.2	4.4	2.0	0.98
1 1/2	(N)ERP015SD	22.4	11.8	11.0	2.7	1.4	5.0	3.35	1.4	4.4	2.8	5.2	2.4	1.26
2	(N)ERP020CD	27.4	11.8	11.0	2.7	1.5	5.0	3.35	1.4	4.4	2.8	5.2	2.4	1.26
2	(N)ERP020LD	25.0	11.8	11.0	2.7	1.6	5.0	3.35	1.4	4.4	2.8	5.2	2.4	1.26
2	(N)ERP020SD	25.6	11.8	11.0	2.7	1.6	5.0	3.35	1.4	4.4	2.8	5.2	2.4	1.26
2 1/2	(N)ERP025SD	26.8	12.6	12.8	3.1	1.6	5.8	3.94	1.4	5.3	3.1	6.0	2.7	1.42
3	(N)ERP030LD*	30.3	12.6	12.8	3.1	1.7	5.8	3.94	1.4	5.3	3.1	6.0	2.7	1.42
3	(N)ERP030CD	32.7	12.6	12.8	3.1	1.8	5.8	3.94	1.4	5.3	3.1	6.0	2.7	1.42
5	(N)ERP050LD	33.1	11.7	15.7	2.1	1.9	6.7	4.65	1.8	5.6	3.2	7.0	3.4	2.13

*The (N)ERP030LD listed is the previous hoist model. Refer to Harrington catalog C-EPH for features and benefits.
Speed ratio is 6:1 with adjustability up to 12:1.

NERP/ERP and NERG/ERG Electric Chain Hoists with Push or Geared Trolleys



NERG/ERG050LD

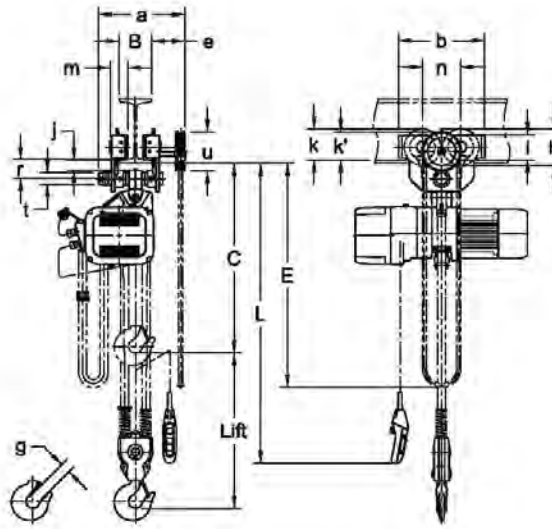

NERG/ERG050LD

DUAL SPEED HOIST WITH GEARED TROLLEY — DIMENSIONS

Cap. (Tons)	Product Code	Headroom C (in)	E (ft)	a (in)	b (in)	e (in)	g (in)	h (in)	i (in)	j (in)	k (in)	k' (in)	m (in)	n (in)	r (in)	t (in)	u (in)
1/8	(N)ERG001HD	16.3	10.5	13.6	9.3	6.0	1.1	4.2	2.80	1.1	3.7	4.2	2.2	4.4	1.9	0.98	7.2
1/4	(N)ERG003SD	16.3	10.5	13.6	9.3	6.0	1.1	4.2	2.80	1.1	3.7	4.2	2.2	4.4	1.9	0.98	7.2
1/4	(N)ERG003HD	17.1	10.5	13.6	9.3	6.0	1.1	4.2	2.80	1.1	3.7	4.2	2.2	4.4	1.9	0.98	7.2
1/2	(N)ERG005LD	17.1	10.5	13.6	9.3	6.0	1.1	4.2	2.80	1.1	3.7	4.2	2.2	4.4	1.9	0.98	7.2
1/2	(N)ERG005SD	17.1	10.5	13.6	9.3	6.0	1.1	4.2	2.80	1.1	3.7	4.2	2.2	4.4	1.9	0.98	7.2
1	(N)ERG010LD	18.5	10.5	13.6	9.3	6.0	1.2	4.2	2.80	1.1	3.7	4.2	2.2	4.4	1.9	0.98	7.2
1	(N)ERG010SD	18.5	10.5	13.6	9.3	6.0	1.2	4.2	2.80	1.1	3.7	4.2	2.2	4.4	1.9	0.98	7.2
1 1/2	(N)ERG015SD	22.4	10.5	15.2	11.0	6.1	1.4	5.0	3.35	1.4	4.4	4.3	2.8	5.2	2.4	1.26	7.2
2	(N)ERG020CD	27.0	10.5	15.2	11.0	6.1	1.5	5.0	3.35	1.4	4.4	4.3	2.8	5.2	2.4	1.26	7.2
2	(N)ERG020LD	25.0	10.5	15.2	11.0	6.1	1.6	5.0	3.35	1.4	4.4	4.3	2.8	5.2	2.4	1.26	7.2
2	(N)ERG020SD	25.6	10.5	15.2	11.0	6.1	1.6	5.0	3.35	1.4	4.4	4.3	2.8	5.2	2.4	1.26	7.2
2 1/2	(N)ERG025SD	26.8	11.0	15.7	12.8	6.2	1.6	5.8	3.94	1.4	5.3	4.5	3.1	6.0	2.7	1.42	7.2
3	(N)ERG030LD*	30.3	11.0	15.7	12.8	6.2	1.7	5.8	3.94	1.4	5.3	4.5	3.1	6.0	2.7	1.42	7.2
3	(N)ERG030CD	32.7	11.0	15.7	12.8	6.2	1.8	5.8	3.94	1.4	5.3	4.5	3.1	6.0	2.7	1.42	7.2
5	(N)ERG050LD	33.1	11.5	15.8	15.7	6.2	1.9	6.7	4.65	1.8	5.6	5.1	3.2	7.0	3.4	2.13	7.2

*The (N)ERG030LD listed is the previous hoist model. Refer to Harrington catalog C-EPH for features and benefits.
Speed ratio is 6:1 with adjustability up to 12:1.



NER/ER Large Capacity Electric Chain Hoists with Hook and Lug Suspensions



NER/ER100S
(Shown with optional canvas chain containers)

Large capacity lifting is now available in both our NER and ER models. Our three phase electric chain hoists provide the duty cycle, durability and ease of operation needed to support most heavy lifting applications.

Features and Benefits

UL® Listed**

Certified and listed to UL 1340 "Standard for Hoists."

Green Initiative

Built smarter without the use of harmful materials. Environmentally friendly. RoHS compliant.

Heavy-Duty Hook Latches

Standard

Limit Switches

Low-profile upper and lower limit switches are standard.

Extended Chain Life

Decreased chain wear as a result of a revolutionary heat treatment process, improved material and chain size.

Contactors

Mechanically interlocked, heavy-duty contactors on single speed models.

High Air Flow

Cooler motor and brake attributed to an engineered motor fin, fan blade and fan cover design.

Unique Load Sheave

Increased number of pockets reduce chain vibration and increase chain life. 5 pockets standard.

Friction Clutch and Load Brake

Friction clutch is standard on NER/ER models and friction clutch with mechanical load brake standard on ER models. Carbon friction material provides consistent performance over a wide temperature range.

Standard Count Hour Meter

Records and displays the number of lowering starts and hoist on time which is valuable for preventive maintenance. Integral to VFD on dual speed models.

High Strength, Corrosion and Wear Resistant Load Chain

Grade 80, super strength, nickel-plated load chain, certified to DIN standards, uses unique technology to greatly increase resistance to fatigue and wear.

Dual Speed VFD

Under-the-cover VFD standard for dual speed hoists. Speed ratio is 3:1 with adjustability up to 12:1.

"The Guardian": Smart Brake Technology

A current driven electromagnetic brake does not release unless the motor is energized. 10 year hoist brake warranty.

Pendant Controls

Ergonomic design for operator comfort. Red button emergency stop is standard on all 2-button dual speed pendants.

Standard Hoist Specifications

Large Capacity Range

NER/ER 8 Ton – 20 Ton
(See page 8 for 1/8 – 5 Ton)

Standard Voltage

208-230/460-3-60
Optional voltages available
Dual speed models are not reconnectable

Control Voltage

110V (optional 24V)

Classification*

ASME H4
ISO M4
FEM 2m or 1Am

Conformance**

UL 1340

Duty Cycle*

Single Speed – 60 Min.
Dual Speed – 30/10 Min. with VFD

Ratings

Hoist – IP55
Pendant – IP65

Upper / Lower Limit Switch

Overwinding/overlifting device
Standard on all models

Standard Pendants

Single speed: 2-button (momentary contacts)
Dual speed: 2-button (momentary contacts) with emergency On/Off (maintained contacts)

Standard Lift

10' (longer lifts available)

Standard Pendant Drop

4' less than lift (longer drops available)

Standard Power Supply Length

30' (longer lengths available)

Mounting

Hook, lug or trolley

Chain Containers

Optional
Canvas or steel

Operating Conditions

Recommended for -4° to +104° F and humidity of 85% or less.

NER vs. ER Features

ER model has same high-quality features as NER plus the following:

- Second brake—Weston-style mechanical load brake

*See page 59 for additional information.

** Most models shipped with UL listing. Contact Customer Service for listed models.



NER/ER100S
(Shown with optional
canvas chain containers)

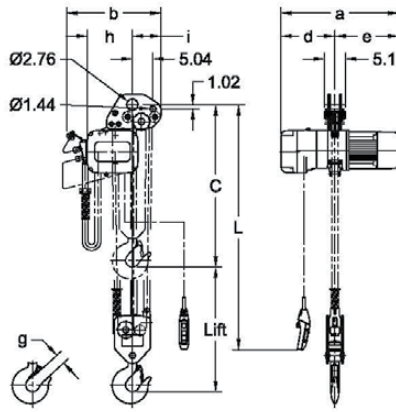

NER/ER080S

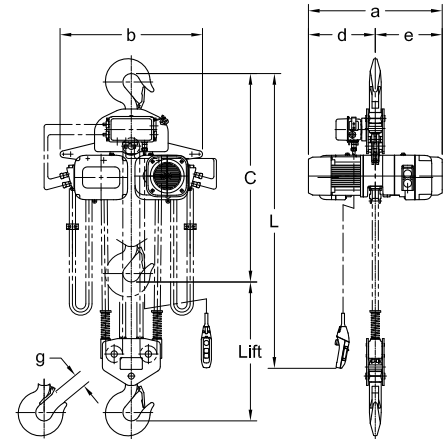

NER/ER100S

SINGLE SPEED — SPECIFICATIONS

Cap. (Tons)	Product Code	Std. Lift (ft)	Push Button Cord L (ft)	Lifting Speed (ft/min)	Lifting Motor 3 Phase 60 Hz			Load Chain Diameter (mm) x Chain Fall Lines	Net Weight (lbs)		Weight for Additional One Foot of Lift (lbs)
					Output (Hp)	Rated Current (amps)			NER	ER	
						@208 – 230V	@460V				
8	(N)ER080S*	10	10.5	7.5	4.7	16.4	7.9	11.2 x 3	362	359	5.5
10	(N)ER100L		11.2	5.5	4.7	16.4	7.9	11.2 x 4	617	615	7.4
10	(N)ER100L-LG*		10.5	5.5	4.7	16.4	7.9	11.2 x 4	573	571	7.4
10	(N)ER100S		11.2	11	4.7 x 2	16.4 x 2	7.9 x 2	11.2 x 4	668	666	7.4
15	(N)ER150S		12.1	7.5	4.7 x 2	16.4 x 2	7.9 x 2	11.2 x 6	891	886	11.4
20	(N)ER200S			5.5	4.7 x 2	16.4 x 2	7.9 x 2	11.2 x 8	1049	1045	14.8

*Available lug mount only. Push button cord dimension (L) is to center of lug hole.

SINGLE SPEED — DIMENSIONS

Cap. (Tons)	Product Code	Headroom C (in)	a (in)		b (in)	d (in)		e (in)		g (in)	h (in)	i (in)
			NER	ER		NER	ER	NER	ER			
8	(N)ER080S	40.3	28.9	32.5	23.2	13.2	16.8	15.7	16.8	2.5	11.1	7.1
10	(N)ER100L	53.9	28.9	32.5	38.3	13.2	16.8	15.7	16.8	3.2	13.3	20.0
10	(N)ER100L-LG	40.9	28.9	32.5	26.9	13.2	16.8	15.7	16.8	3.2	13.3	8.5
10	(N)ER100S	53.9	31.4	33.6	33.4	15.7	16.8	15.7	16.8	3.2	-	-
15	(N)ER150S	62.8	31.4	33.6	40.2	15.7	16.8	15.7	16.8	3.4	-	-
20	(N)ER200S	67.3	31.4	33.6	47.2	15.7	16.8	15.7	16.8	4.1	-	-

NER/ER Large Capacity Electric Chain Hoists with Hook and Lug Suspensions



NER/ER100SD
(Shown with optional canvas chain containers)

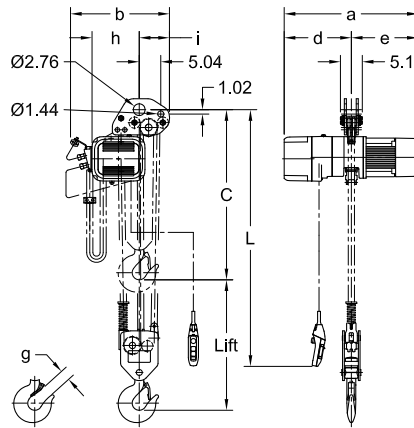

NER/ER080SD

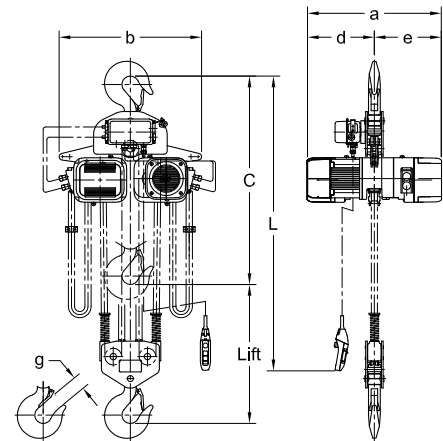

NER/ER100SD

DUAL SPEED — SPECIFICATIONS

Cap. (Tons)	Product Code	Std. Lift (ft)	Push Button Cord L (ft)	Lifting Speed (ft/min)	Lifting Motor** 3 Phase 60 Hz			Load Chain Diameter (mm) x Chain Fall Lines	Net Weight (lbs)		Weight for Additional One Foot of Lift (lbs)
					Output (Hp)	Rated Current (amps)			NER	ER	
						@208 – 230V	@460V				
8	(N)ER080SD*	10	10.5	7.5/2.5	4.7	17.3	8.3	11.2 x 3	358	366	5.5
10	(N)ER100LD		11.2	5.5/2	4.7	17.3	8.3	11.2 x 4	609	622	7.4
10	(N)ER100LD-LG*		10.5	5.5/2	4.7	17.3	8.3	11.2 x 4	569	578	7.4
10	(N)ER100SD		11.2	11/3.5	4.7 x 2	17.3 x 2	8.3 x 2	11.2 x 4	650	677	7.4
15	(N)ER150SD		12.1	7.5/2.5	4.7 x 2	17.3 x 2	8.3 x 2	11.2 x 6	873	899	11.4
20	(N)ER200SD			5.5/2	4.7 x 2	17.3 x 2	8.3 x 2	11.2 x 8	1032	1058	14.8

*Available lug mount only. Push button cord dimension (L) is to center of lug hole.
**Although both 208/230 & 460 Volts are shown together, the motors are NOT reconnectable. Speed ratio is 3:1 with adjustability up to 12:1.

DUAL SPEED — DIMENSIONS

Cap. (Tons)	Product Code	Headroom C (in)	a (in)		b (in)	d (in)		e (in)		g (in)	h (in)	i (in)
			NER	ER		NER	ER	NER	ER			
8	(N)ER080SD	40.3	31.5	32.5	23.2	15.8	16.8	15.7	15.7	2.5	11.1	7.1
10	(N)ER100LD	53.9	31.5	32.5	38.3	15.8	16.8	15.7	15.7	3.2	13.3	20.0
10	(N)ER100LD-LG	40.9	31.5	32.5	26.9	15.8	16.8	15.7	15.7	3.2	13.3	8.5
10	(N)ER100SD	53.9	31.5	33.6	33.4	15.8	16.8	15.8	16.8	3.2	-	-
15	(N)ER150SD	62.8	31.5	33.6	40.2	15.8	16.8	15.8	16.8	3.4	-	-
20	(N)ER200SD	67.3	31.5	33.6	47.2	15.8	16.8	15.8	16.8	4.1	-	-

Speed ratio is 3:1 with adjustability up to 12:1.

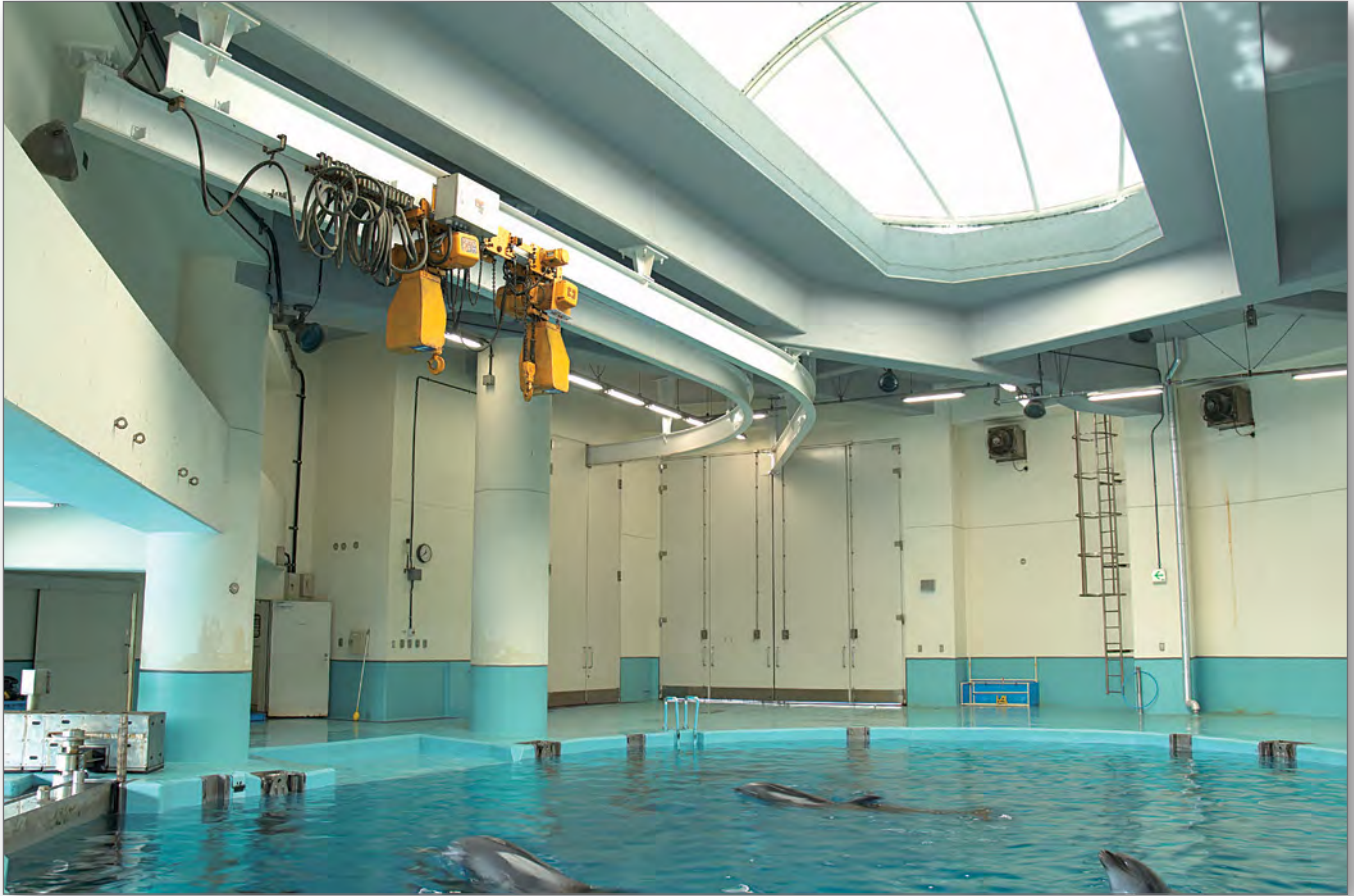

NERM/ERM Large Capacity Electric Chain Hoists with Motorized Trolleys



NERM/ERM100S-L
(Shown with optional canvas chain containers)

MR trolleys are suitable for harsh or outdoor applications and easily couple with NER/ER large capacity hoists for the heaviest lifting and traversing requirements. Features include thermal motor protection, side guide rollers for smooth operation and plug in electrical connections.

Features and Benefits

UL® Listed**

Certified and listed to UL 1340 "Standard for Hoists."

Perpendicular Orientation

MR motorized trolley mount hoists are configured as perpendicular to the beam.

Green Initiative

Built smarter without the use of harmful materials. Environmentally friendly. RoHS compliant.

Heavy-Duty Hook Latches

Standard

High Air Flow

Cooler motor and brake attributed to an engineered motor fin, fan blade and fan cover design.

Unique Load Sheave

Increased number of pockets reduce chain vibration and increase chain life. 5 pockets standard.

Extended Chain Life

Decreased chain wear as a result of a revolutionary heat treatment process, improved material and chain size.

Limit Switches

Low-profile upper and lower limit switches are standard.

Contactors

Mechanically interlocked, heavy-duty contactors on single speed models.

Friction Clutch and Load Brake

Friction clutch is standard on NER/ER models and friction clutch with mechanical load brake standard on ER models. Carbon friction material provides consistent performance over a wide temperature range.

Dual Speed VFD

Under-the-cover VFD standard for dual speed hoists. Speed ratio is 3:1 with adjustability up to 12:1.

High Strength, Corrosion and Wear Resistant Load Chain

Grade 80, super strength, nickel-plated load chain, certified to DIN standards, uses unique technology to greatly increase resistance to fatigue and wear.

Standard Count Hour Meter

Records and displays the number of lowering starts and hoist on time which is valuable for preventive maintenance. Integral to VFD on dual speed models.

"The Guardian": Smart Brake Technology

A current driven electromagnetic brake does not release unless the motor is energized. 10 year hoist brake warranty.

Pendant Controls

Ergonomic design for operator comfort. Red button emergency stop is standard on all 4-button pendants.

Standard Motorized Trolley Specifications

Capacity Range

8 Ton – 20 Ton
(See page 14 for 1/8 – 5 Ton)

Standard Voltage

208-230/460-3-60
Optional voltages available
Dual speed models are not reconnectable

Control Voltage

110V (optional 24V)

Duty Cycle*

Single Speed – 30 Min.
Dual Speed – 30 Min. with VFD

Classification*

ASME H4
ISO M4
FEM 2m or 1Am

Ratings

Trolley – IP55
Pendant – IP65

Standard Power Supply Length

30' (longer lengths available)

Shafts

Standard shafts fit wide flange range
Longer shafts for wider beams
Spacers for easy adjustments

Standard Pendants

4-button (momentary contacts) with emergency On/Off (maintained contacts)

Drop Stops

Standard

Standard Pendant Drop

4' less than lift
(longer drops available)

Bumpers

Standard

Wheels

All steel
Shielded ball bearings
Fit flat or tapered beam flange

*See page 59 for additional information.

**Most models shipped with UL listing. Contact Customer Service for listed models.

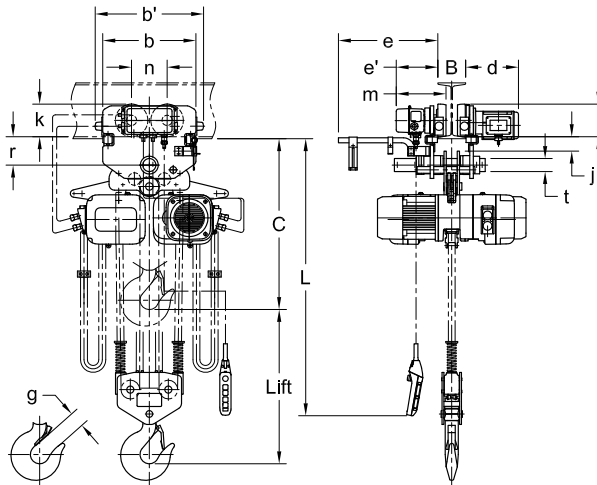

NERM/ERM100S-L

NERM/ERM100S-L
(Shown with optional
canvas chain containers)

SINGLE SPEED HOIST WITH SINGLE SPEED TROLLEY — SPECIFICATIONS

Cap. (Tons)	Product Code	Std. Lift (ft)	Push Button Cord L (ft)	Lifting Speed (ft/min)	Traversing Speed (ft/min)	Lifting Motor 3 Phase 60 Hz			Traversing Motor 3 Phase 60 Hz			Flange Width Adjustability B (in)		Minimum Allow. Radius for Curve (in)	Load Chain Diameter (mm) x Chain Fall Lines	Net Weight (lbs)		Weight for Additional One Foot of Lift (lbs)
						Output (Hp)	Rated Current (amps)		Output (Hp)	Rated Current (amps)		Standard	Optional			NER	ER	
							@208-230V	@460V		@208-230V	@460V							
8	(N)ERM080S-L	10	10.8	7.5	40	4.7	16.4	7.9	1.0	5.1	2.5	5.50 to 8.66	8.67 to 12.00	98.4	11.2 x 3	624	622	5.5
10	(N)ERM100L-L			5.5		4.7	16.4	7.9	1.0	5.1	2.5			98.4	11.2 x 4	833	831	7.4
10	(N)ERM100S-L			11		4.7 x 2	16.4 x 2	7.9 x 2	1.0	5.1	2.5			98.4	11.2 x 4	880	877	7.4
15	(N)ERM150S-L			7.5		4.7 x 2	16.4 x 2	7.9 x 2	1.0 x 2	5.1 x 2	2.5 x 2			∞	11.2 x 6	1259	1254	11.4
20	(N)ERM200S-L			5.5		4.7 x 2	16.4 x 2	7.9 x 2	1.0 x 2	5.1 x 2	2.5 x 2			∞	11.2 x 8	1482	1479	14.8

SINGLE SPEED HOIST WITH SINGLE SPEED TROLLEY — DIMENSIONS

Cap. (Tons)	Product Code	Headroom C (in)	b (in)	b' (in)	d (in)	e (in)	e' (in)	g (in)	i (in)	j (in)	k (in)	m (in)	n (in)	r (in)	t (in)
8	(N)ERM080S-L	45.9	19.7	22.9	11.2	20.9	8.8	2.5	6.89	3.4	6.9	10.5	7.5	6.0	2.76
10	(N)ERM100L-L	46.5	19.7	22.9	11.2	20.9	8.8	3.2	6.89	3.1	6.9	10.5	7.5	6.0	2.76
10	(N)ERM100S-L	46.5	19.7	22.9	11.2	20.9	8.8	3.2	6.89	3.1	6.9	10.5	7.5	6.0	2.76
15	(N)ERM150S-L	51.6	40.2	43.4	11.2	20.9	8.8	3.4	6.89	3.2	6.9	10.5	28.0	6.0	2.76
20	(N)ERM200S-L	53.0	40.2	43.4	11.2	20.9	8.8	4.1	6.89	3.1	6.9	10.5	28.0	6.0	2.76

NERM/ERM Large Capacity Electric Chain Hoists with Motorized Trolleys



NERM/ERM100SD-L
(Shown with optional canvas chain containers)

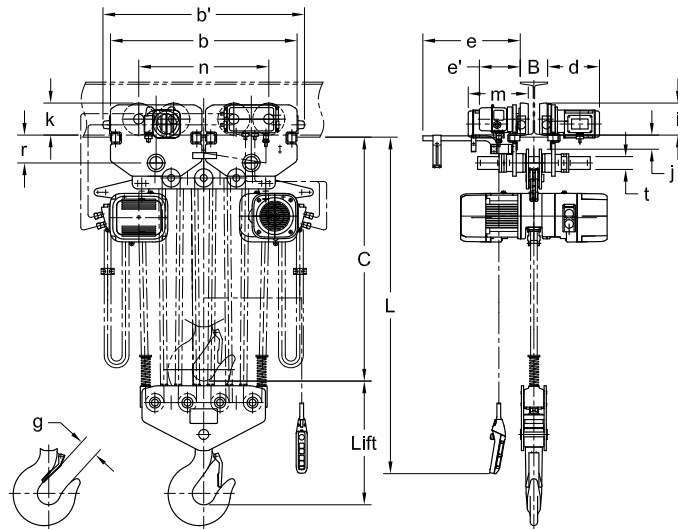

NERM/ERM200SD-L

DUAL SPEED HOIST WITH SINGLE SPEED TROLLEY — SPECIFICATIONS

Cap. (Tons)	Product Code	Std. Lift (ft)	Push Button Cord L (ft)	Lifting Speed (ft/min)	Traversing Speed (ft/min)	Lifting Motor** 3 Phase 60 Hz			Traversing Motor 3 Phase 60 Hz			Flange Width Adjustability B (in)		Minimum Allow. Radius for Curve (in)	Load Chain Diameter (mm) x Chain Fall Lines	Net Weight (lbs)		Weight for Additional One Foot of Lift (lbs)
						Output (Hp)	Rated Current (amps)		Output (Hp)	Rated Current (amps)		Standard	Optional			NER	ER	
							@208-230V	@460V		@208-230V	@460V							
8	(N)ERM080SD-L	10	10.8	7.5/2.5	40	4.7	17.3	8.3	1.0	5.1	2.5	5.50 to 8.66	8.67 to 12.00	98.4	11.2 x 3	615	628	5.5
10	(N)ERM100LD-L			5.5/2		4.7	17.3	8.3	1.0	5.1	2.5			98.4	11.2 x 4	825	838	7.4
10	(N)ERM100SD-L			11/3.5		4.7 x 2	17.3 x 2	8.3 x 2	1.0	5.1	2.5			98.4	11.2 x 4	862	888	7.4
15	(N)ERM150SD-L			7.5/2.5		4.7 x 2	17.3 x 2	8.3 x 2	1.0 x 2	5.1 x 2	2.5 x 2			∞	11.2 x 6	1241	1268	11.4
20	(N)ERM200SD-L			5.5/2		4.7 x 2	17.3 x 2	8.3 x 2	1.0 x 2	5.1 x 2	2.5 x 2			∞	11.2 x 8	1367	1393	14.8

**Although both 208/230 & 460 Volts are shown together, the motors are NOT reconnectable.
Speed ratio is 3:1 with adjustability up to 12:1.

DUAL SPEED HOIST WITH SINGLE SPEED TROLLEY — DIMENSIONS

Cap. (Tons)	Product Code	Headroom C (in)	b (in)	b' (in)	d (in)	e (in)	e' (in)	g (in)	i (in)	j (in)	k (in)	m (in)	n (in)	r (in)	t (in)
8	(N)ERM080SD-L	45.9	19.7	22.9	11.2	20.9	8.8	2.5	6.89	3.4	6.9	10.5	7.5	6.0	2.76
10	(N)ERM100LD-L	46.5	19.7	22.9	11.2	20.9	8.8	3.2	6.89	3.1	6.9	10.5	7.5	6.0	2.76
10	(N)ERM100SD-L	46.5	19.7	22.9	11.2	20.9	8.8	3.2	6.89	3.1	6.9	10.5	7.5	6.0	2.76
15	(N)ERM150SD-L	51.6	40.2	43.4	11.2	20.9	8.8	3.4	6.89	3.2	6.9	10.5	28.0	6.0	2.76
20	(N)ERM200SD-L	53.0	40.2	43.4	11.2	20.9	8.8	4.1	6.89	3.1	6.9	10.5	28.0	6.0	2.76

Speed ratio is 3:1 with adjustability up to 12:1.



NERP/ERP and NERG/ERG Large Capacity Electric Chain Hoists with Push or Geared Trolleys



NERP/ERP080S
(Shown with optional canvas chain container)

Harrington's PT push and GT geared trolleys provide added mobility to NER/ER hoists and feature a compact, lightweight design for ease of installation and use. Manual trolleys are the best choice for jobs requiring infrequent moves.

Features and Benefits

UL® Listed**

Certified and listed to UL 1340 "Standard for Hoists."

Perpendicular Orientation

PT push trolley mount hoists are configured as perpendicular to the beam.

Green Initiative

Built smarter without the use of harmful materials. Environmentally friendly. RoHS compliant.

Heavy-Duty Hook Latches

Standard

High Air Flow

Cooler motor and brake attributed to an engineered motor fin, fan blade and fan cover design.

Extended Chain Life

Decreased chain wear as a result of a revolutionary heat treatment process, improved material and chain size.

Unique Load Sheave

Increased number of pockets reduce chain vibration and increase chain life. 5 pockets standard.

Limit Switches

Low-profile upper and lower limit switches are standard.

Contactors

Mechanically interlocked, heavy-duty contactors on single speed models.

Friction Clutch and Load Brake

Friction clutch is standard on NER/ER models and friction clutch with mechanical load brake standard on ER models. Carbon friction material provides consistent performance over a wide temperature range.

Dual Speed VFD

Under-the-cover VFD standard for dual speed hoists. Speed ratio is 3:1 with adjustability up to 12:1.

High Strength, Corrosion and Wear Resistant Load Chain

Grade 80, super strength, nickel-plated load chain, certified to DIN standards, uses unique technology to greatly increase resistance to fatigue and wear.

Standard Count Hour Meter

Records and displays the number of lowering starts and hoist on time which is valuable for preventive maintenance. Integral to VFD on dual speed models.

"The Guardian": Smart Brake Technology

A current driven electromagnetic brake does not release unless the motor is energized. 10 year hoist brake warranty.

Pendant Controls

Ergonomic design for operator comfort. Red button emergency stop is standard on all 2-button dual speed pendants.

Standard Trolley Specifications

Capacity Range

Push – 8 Ton – 10 Ton
Geared – 8 Ton – 20 Ton
(See page 22 for 1/8 – 5 Ton)

Shafts

Standard shafts fit wide flange range
Longer shafts for wider beams
Spacers for easy adjustments

Drop Stops

Standard

Bumpers

Optional

Standard Hand Chain Drop

On geared trolleys
2' less than lift (longer drops available)

Wheels

All steel
Shielded ball bearings
Fit flat or tapered beam flange

Standard Hoist Pendant Drop

4' less than lift
(longer drops available)

Standard Hoist Power Supply Length

30' (longer lengths available)

Standard Pendants

Single speed: 2-button (momentary contacts)
Dual speed: 2-button (momentary contacts) with emergency On/Off (maintained contacts)

**Most models shipped with UL listing. Contact Customer Service for listed models.

HARRINGTON ELECTRIC CHAIN HOISTS

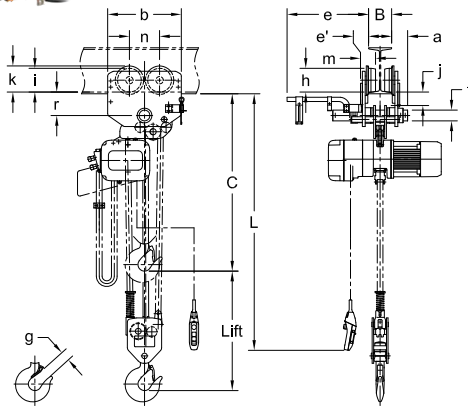

NERP/ERP080S

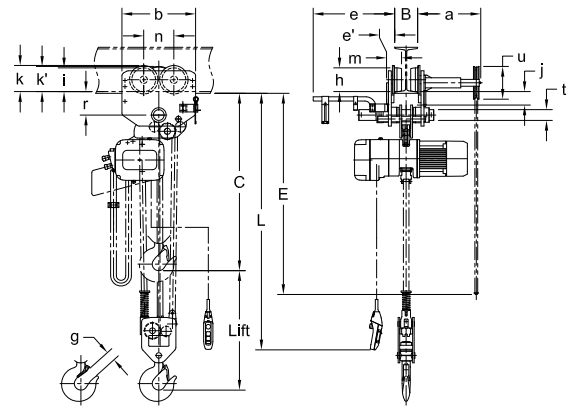

NERG/ERG080S

NERP/ERP080S
(Shown with optional
canvas chain container)

SINGLE SPEED HOIST WITH PUSH OR GEARED TROLLEY — SPECIFICATIONS

Cap. (Tons)	Product Code	Std. Lift (ft)	Push Button Cord L (ft)	Lifting Speed (ft/min)	Lifting Motor 3 Phase 60 Hz			Flange Width Adjustability B (in)		Minimum Allow. Radius for Curve (in)	Load Chain Diameter (mm) x Chain Fall Lines	Net Weight (lbs)		Weight for Additional One Foot of Lift (lbs)
					Output (Hp)	Rated Current (amps)		Standard	Optional			NER	ER	
						@208 - 230V	@460V							
8	(N)ERP(ERG)080S	10	10.8	7.5	4.7	16.4	7.9	5.50 to 8.66	8.67 to 12.00	118.1	11.2 x 3	536 (604)	534 (602)	5.5 (6.3)
10	(N)ERP(ERG)100L			5.5	4.7	16.4	7.9			118.1	11.2 x 4	747 (816)	745 (814)	7.4 (8.1)
10	(N)ERP(ERG)100S			11	4.7 x 2	16.4 x 2	7.9 x 2			118.1	11.2 x 4	805 (873)	802 (871)	7.4 (8.1)
15	(N)ERG150S			7.5	4.7 x 2	16.4 x 2	7.9 x 2			∞	11.2 x 6	1246	1241	12.8
20	(N)ERG200S			5.5	4.7 x 2	16.4 x 2	7.9 x 2			∞	11.2 x 8	1371	1369	16.1

Figures in parentheses are data for geared trolley.

SINGLE SPEED HOIST WITH PUSH TROLLEY — DIMENSIONS

Cap. (Tons)	Product Code	Headroom C (in)	a (in)	b (in)	e (in)	e' (in)	g (in)	h (in)	i (in)	j (in)	k (in)	m (in)	n (in)	r (in)	t (in)
8	(N)ERP080S	45.9	4.1	18.9	20.9	1.6	2.5	7.3	6.10	3.4	6.7	3.4	7.7	6.0	2.76
10	(N)ERP100L	46.5	4.1	18.9	20.9	1.6	3.2	7.3	6.10	3.1	6.7	3.4	7.7	6.0	2.76
10	(N)ERP100S	46.5	4.1	18.9	20.9	8.8	3.2	7.3	6.10	3.1	6.7	10.6	7.7	6.0	2.76

SINGLE SPEED HOIST WITH GEARED TROLLEY — DIMENSIONS

Cap. (Tons)	Product Code	Headroom C (in)	E (ft)	a (in)	b (in)	e (in)	e' (in)	g (in)	h (in)	i (in)	j (in)	k (in)	k' (in)	m (in)	n (in)	r (in)	t (in)	u (in)
8	(N)ERG080S	45.9	10.5	16.2	18.9	20.9	1.6	2.5	7.3	6.10	3.4	6.7	6.5	3.4	7.7	6.0	2.76	8.4
10	(N)ERG100L	46.5	10.5	16.2	18.9	20.9	1.6	3.2	7.3	6.10	3.1	6.7	6.5	3.4	7.7	6.0	2.76	8.4
10	(N)ERG100S	46.5	10.5	16.2	18.9	20.9	8.8	3.2	7.3	6.10	3.1	6.7	6.5	10.6	7.7	6.0	2.76	8.4
15	(N)ERG150S	51.6	12.1	16.2	39.4	20.9	8.8	3.4	7.3	6.10	3.2	6.7	6.5	10.6	28.2	6.0	2.76	8.4
20	(N)ERG200S	53.0	12.1	16.2	39.4	20.9	8.8	4.1	7.3	6.10	3.1	6.7	6.5	10.6	28.2	6.0	2.76	8.4

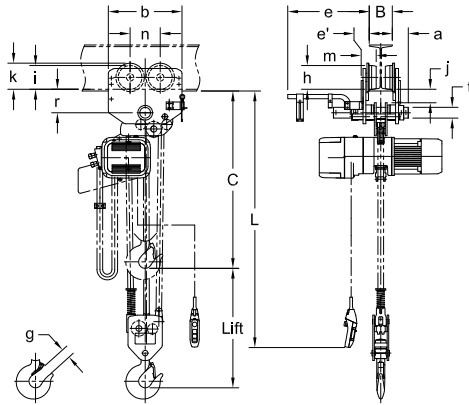
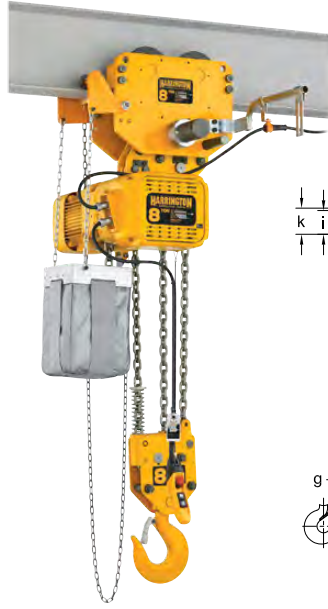

NERP/ERP080SD

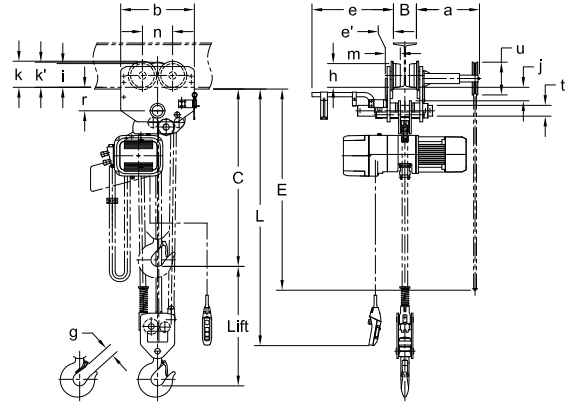

NERG/ERG080SD

NERG/ERG080S-SD
(Shown with optional
canvas chain container)

DUAL SPEED HOIST WITH PUSH OR GEARED TROLLEY — SPECIFICATIONS

Cap. (Tons)	Product Code	Std. Lift (ft)	Push Button Cord L (ft)	Lifting Speed (ft/min)	Lifting Motor 3 Phase 60 Hz**			Flange Width Adjustability B (in)		Minimum Allow. Radius for Curve (in)	Load Chain Diameter (mm) x Chain Fall Lines	Net Weight (lbs)		Weight for Additional One Foot of Lift (lbs)
					Output (Hp)	Rated Current (amps)		Standard	Optional			NER	ER	
						@208 – 230V	@460V							
8	(N)ERP(ERG)080SD	10	10.8	7.5/2.5	4.7	17.3	8.3	5.50 to 8.66	8.67 to 12.00	118.1	11.2 x 3	527 (595)	541 (609)	5.5 (6.3)
10	(N)ERP(ERG)100LD			5.5/2	4.7	17.3	8.3			118.1	11.2 x 4	738 (807)	752 (821)	7.4 (8.1)
10	(N)ERP(ERG)100SD			11/3.5	4.7 x 2	17.3 x 2	8.3 x 2			118.1	11.2 x 4	787 (855)	809 (884)	7.4 (8.1)
15	(N)ERG150SD			7.5/2.5	4.7 x 2	17.3 x 2	8.3 x 2			∞	11.2 x 6	1228	1254	12.8
20	(N)ERG200SD			5.5/2	4.7 x 2	17.3 x 2	8.3 x 2			∞	11.2 x 8	1353	1382	16.1

Figures in parentheses are data for geared trolley.

**Although both 208/230 & 460 Volts are shown together, the motors are NOT reconnectable.

DUAL SPEED HOIST WITH PUSH TROLLEY — DIMENSIONS

Cap. (Tons)	Product Code	Headroom C (in)	a (in)	b (in)	e (in)	e' (in)	g (in)	h (in)	i (in)	j (in)	k (in)	m (in)	n (in)	r (in)	t (in)
8	(N)ERP080SD	45.9	4.1	18.9	20.9	1.6	2.5	7.3	6.10	3.4	6.7	3.4	7.7	6.0	2.76
10	(N)ERP100LD	46.5	4.1	18.9	20.9	1.6	3.2	7.3	6.10	3.1	6.7	3.4	7.7	6.0	2.76
10	(N)ERP100SD	46.5	4.1	18.9	20.9	8.8	3.2	7.3	6.10	3.1	6.7	10.6	7.7	6.0	2.76

DUAL SPEED HOIST WITH GEARED TROLLEY — DIMENSIONS

Cap. (Tons)	Product Code	Headroom C (in)	E (ft)	a (in)	b (in)	e (in)	e' (in)	g (in)	h (in)	i (in)	j (in)	k (in)	k' (in)	m (in)	n (in)	r (in)	t (in)	u (in)
8	(N)ERG080SD	45.9	10.5	16.2	18.9	20.9	1.6	2.5	7.3	6.10	3.4	6.7	6.5	3.4	7.7	6.0	2.76	8.4
10	(N)ERG100LD	46.5	10.5	16.2	18.9	20.9	1.6	3.2	7.3	6.10	3.1	6.7	6.5	3.4	7.7	6.0	2.76	8.4
10	(N)ERG100SD	46.5	10.5	16.2	18.9	20.9	8.8	3.2	7.3	6.10	3.1	6.7	6.5	10.6	7.7	6.0	2.76	8.4
15	(N)ERG150SD	51.6	12.1	16.2	39.4	20.9	8.8	3.4	7.3	6.10	3.2	6.7	6.5	10.6	28.2	6.0	2.76	8.4
20	(N)ERG200SD	53.0	12.1	16.2	39.4	20.9	8.8	4.1	7.3	6.10	3.1	6.7	6.5	10.6	28.2	6.0	2.76	8.4

Speed ratio is 3:1 with adjustability up to 12:1.



NER Dual Speed Electric Chain Hoists

Smart Limit Option



NER010LD
(With Smart Limit)

Harrington's unique Smart Limit is available on NER three phase dual speed electric chain hoists. Unlike geared limit switches, this Smart Limit allows the user to add upper and lower limit positions that can be conveniently programmed at the pendant. The soft stop feature within the Smart Limit slows the hook down as it approaches each limit for smooth and very precise load positioning.

Features and Benefits

Easy Access Suspension

External pins allow for quick change from hook to lug for trolley mount configurations on most models.

Green Initiative

Built smarter without the use of harmful materials. Environmentally friendly. RoHS compliant.

Notched Hook and Latch System

Provides positive closing and improves resistance against lateral forces.

Limit Switches

Low-profile upper and lower limit switches are standard. Plus additional programmable upper and lower limit for four limit locations.

Extended Chain Life

Decreased chain wear as a result of a revolutionary heat treatment process, improved material and chain size.

High Air Flow

Cooler motor and brake attributed to an engineered motor fin, fan blade and fan cover design.

Unique Load Sheave

Increased number of pockets reduce chain vibration and increase chain life. 5 pockets standard; 6 pockets on smaller body hoists.

Friction Clutch and Load Brake

Friction clutch is standard on NER/ER models and friction clutch with mechanical load brake standard on ER models. Carbon friction material provides consistent performance over a wide temperature range.

Standard Count Hour Meter

Records and displays the number of lowering starts and hoist on time which is valuable for preventive maintenance. Integral to VFD on dual speed models.

Contactors

Mechanically interlocked, heavy-duty contactors on single speed models.

High Strength, Corrosion and Wear Resistant Load Chain

Grade 80, super strength, nickel-plated load chain, certified to DIN standards, uses unique technology to greatly increase resistance to fatigue and wear.

Dual Speed VFD

Under-the-cover VFD standard for dual speed hoists. Speed ratio is 6:1 with adjustability up to 12:1.

"The Guardian": Smart Brake Technology

A current driven electromagnetic brake does not release unless the motor is energized. 10 year hoist brake warranty.

Pendant Controls

Ergonomic design for operator comfort. Red button emergency stop is standard on all 2-button dual speed pendants.

Standard Hoist Specifications

Capacity Range

NER – 1/8 Ton – 5 Ton

Standard Voltage

208-230 / 460-3-60
Optional voltages available
Dual speed models are not reconnectable

Control Voltage

110V (optional 24V)

Duty Cycle*

Dual Speed – 30/10 Min. with VFD

Classification*

ASME H4
ISO M5 or M4
FEM 2m or 1Am

Ratings

Hoist – IP55
Pendant – IP65

Upper/Lower Limit Switch

Overwinding / overlifting device
Plus additional programmable upper and lower limit for four limit locations

Chain Falls

Single chain fall through 3 Ton

Standard Lift

10' (longer lifts available)

Standard Pendant Drop

4' less than lift (longer drops available)

Standard Power Supply Length

15' (longer lengths available)

Mounting

Hook, lug or trolley

Standard Pendants

Dual speed: 2-button (momentary contacts) with emergency On/Off (maintained contacts)

Chain Containers

Optional
Canvas, plastic or steel

Operating Conditions

Recommended for -4° to +104° F and humidity of 85% or less

*See page 59 for additional information.

HARRINGTON ELECTRIC CHAIN HOISTS



NER010LD (With Smart Limit)

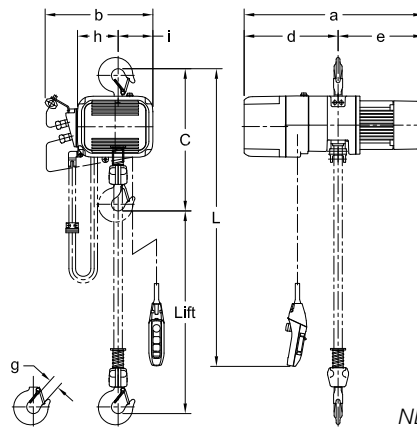

NER020LD (With Smart Limit)

NER DUAL SPEED HOISTS WITH SMART LIMIT — SPECIFICATIONS

Cap. (Tons)	Product Code	Std. Lift (ft)	Push Button Cord L (ft)	Lifting Speed (ft/min)	Lifting Motor 3 Phase 60 Hz*			Load Chain Diameter (mm) x Chain Fall Lines	Net Weight (lbs)	Weight for Additional One Foot of Lift (lbs)
					Output (Hp)	Rated Current (amps)				
						@208 – 230V	@460V	NER		
1/8	NER001HD	10	8.2	55/9	0.75	3.6	1.8	4.3 x 1	60	0.28
1/4	NER003SD			36/6	0.75	3.6	1.8	4.3 x 1	60	0.28
1/4	NER003HD			53/9	1.2	5.1	2.7	6.0 x 1	77	0.54
1/2	NER005LD			15/2.5	0.75	3.6	1.8	6.0 x 1	68	0.54
1/2	NER005SD			29/5	1.2	5.1	2.7	6.0 x 1	77	0.54
1	NER010LD			14/2.5	1.2	5.1	2.7	7.7 x 1	99	0.89
1	NER010SD			28/4.5	2.4	9.1	4.5	7.7 x 1	115	0.89
1 1/2	NER015SD			18/3	2.4	9.1	4.5	10.2 x 1	159	1.6
2	NER020CD			7/1	1.2	5.1	2.7	7.7 x 2	123	1.8
2	NER020LD			14/2.5	2.4	9.1	4.5	10.2 x 1	161	1.6
2	NER020SD			28/4.5	4.7	17.3	8.3	10.2 x 1	196	1.6
2 1/2	NER025SD			22/3.5	4.7	17.3	8.3	11.2 x 1	218	1.9
3	NER030CD			17/3	4.7	17.3	8.3	10.2 x 2	229	3.2
5	NER050LD			11/2	4.7	17.3	8.3	11.2 x 2	280	3.8

*Although 208/230 & 460 Volts are shown, voltage can **NOT** be changed, due to electrical components being voltage specific.

NER DUAL SPEED HOISTS WITH SMART LIMIT — DIMENSIONS

Cap. (Tons)	Product Code	Headroom C (in)	a (in)	b (in)	d (in)	e (in)	g (in)	H (in)	i (in)
1/8	NER001HD	13.8	21.0	13.6	10.8	10.2	1.1	3.9	4.6
1/4	NER003SD	13.8	21.0	13.6	10.8	10.2	1.1	3.9	4.6
1/4	NER003HD*	14.6	22.3	13.7	11.8	10.5	1.1	4.4	4.2
1/2	NER005LD**	14.6	22.4	13.7	11.8	10.6	1.1	4.4	4.2
1/2	NER005SD*	14.6	22.3	13.7	11.8	10.5	1.1	4.4	4.2
1	NER010LD	16.9	24.1	14.8	12.4	11.7	1.2	5.1	4.6
1	NER010SD	16.9	24.5	14.8	12.4	12.1	1.2	5.1	4.6
1 1/2	NER015SD	20.1	27.9	16.8	14.6	13.3	1.4	6.3	5.4
2	NER020CD	27.8	24.1	14.8	12.4	11.7	1.5	7.0	2.7
2	NER020LD	22.6	27.9	16.8	14.6	13.3	1.6	6.3	5.4
2	NER020SD	23.2	30.2	16.8	16.2	14.0	1.6	6.3	5.4
2 1/2	NER025SD	24.6	31.5	17.5	15.8	15.7	1.6	6.8	5.6
3	NER030CD	30.9	30.2	16.8	16.2	14.0	1.8	8.5	3.2
5	NER050LD	33.5	31.5	17.5	15.8	15.7	1.9	9.1	3.4

*For 460V-3-60 NER003HD and NER005SD, Dimension a = 22.9 in. and Dimension d = 12.3 in.

**For 460V-3-60 NER005LD, Dimension a = 23.0 in and Dimension d = 12.3 in.

NER/ER Cylinder Control Electric Chain Hoists with Hook and Lug Suspensions



NER003SCC

We have expanded the benefits of the ergonomically designed cylinder control into our full-featured NER/ER Series of electric chain hoists. For three-phase applications requiring ease of control, one-handed operation, fast lifting speeds and heavy duty production, these hoists will increase productivity, add to operator comfort and answer your ergonomic needs.

Features and Benefits

Easy Access Suspension

External pins allow for quick change from hook to lug for trolley mount configurations on most models.

Green Initiative

Built smarter without the use of harmful materials. Environmentally friendly. RoHS compliant.

Notched Hook and Latch System

Provides positive closing and improves resistance against lateral forces.

Limit Switches

Low-profile upper and lower limit switches are standard.

Extended Chain Life

Decreased chain wear as a result of a revolutionary heat treatment process, improved material and chain size.

Low/High Speeds

Rocker switch above handgrip on dual speed models allows quick selection of low or high speed.

High Air Flow

Cooler motor and brake attributed to an engineered motor fin, fan blade and fan cover design.

Unique Load Sheave

Increased number of pockets reduce chain vibration and increase chain life. 5 pockets standard; 6 pockets on smaller body hoists.

Friction Clutch and Load Brake

Friction clutch is standard on NER/ER models and friction clutch with mechanical load brake standard on ER models. Carbon friction material provides consistent performance over a wide temperature range.

Standard Count Hour Meter

Records and displays the number of lowering starts and hoist on time which is valuable for preventive maintenance. Integral to VFD on dual speed models.

Removable Bottom Hook

Permits insertion of below-the-hook devices.

Contactors

Mechanically interlocked, heavy-duty contactors on single speed models.

High Strength, Corrosion and Wear Resistant Load Chain

Grade 80, super strength, nickel-plated load chain, certified to DIN standards, uses unique technology to greatly increase resistance to fatigue and wear.

Dual Speed VFD

Under-the-cover VFD standard for dual speed hoists. Speed ratio is 6:1 with adjustability up to 12:1.

“The Guardian”: Smart Brake Technology

A current driven electromagnetic brake does not release unless the motor is energized. 10 year hoist brake warranty.

Unique Cylinder Control

In-line handgrip permits one handed operation. Available on hoist or as a kit for field installation.

Standard Hoist Specifications

Capacity Range

NER/ER – 1/8 Ton – 1/4 Ton

Standard Voltage

208-230 / 460-3-60
Optional voltages available
Dual speed models are not reconnectable

Control Voltage

110V (optional 24V)

Duty Cycle*

Single Speed – 60 Min.
Dual Speed – 30/10 Min. with VFD

Classification*

ASME H4
ISO M5
FEM 2m or 1Am

Ratings

Hoist – IP55
Pendant – IP65

Upper/Lower Limit Switch

Overwinding / overlifting device
Standard on all models

Chain Falls

Single chain fall

Standard Lift

6' (longer lifts not available)

Standard Reach

9' (approx)
(reach equals lift plus headroom)

Standard Power Supply Length

15' (longer lengths available)

Mounting

Hook, lug or trolley

Standard Pendants

Single speed: 2-button (momentary contacts)
Dual speed: 2-button (momentary contacts) with emergency On/Off (maintained contacts)

Chain Containers

Standard
Plastic

Operating Conditions

Recommended for -4° to +104° F and humidity of 85% or less.

NER vs. ER Features

ER model has same high-quality features as NER plus the following:

- Second brake—Weston-style mechanical load brake

*See page 59 for additional information.

HARRINGTON ELECTRIC CHAIN HOISTS



NER003SCC

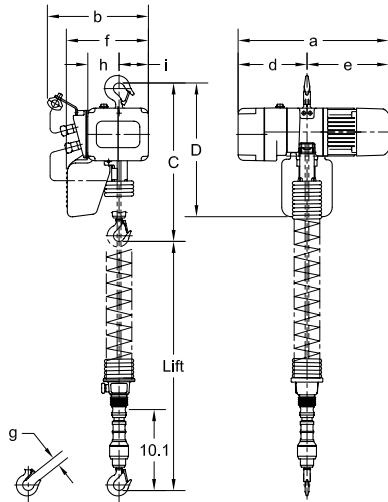

NER003SCC

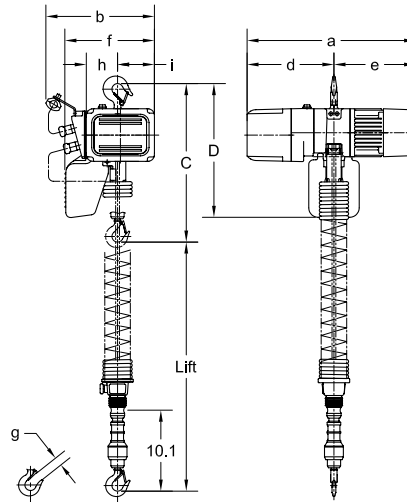

NER003SDCC

Dimensions for NER/ER
Cylinder Control Model (inches)

NER/ER CYLINDER CONTROL — SINGLE SPEED SPECIFICATIONS

Cap. (Tons)	Product Code	Standard Lift (ft)	Lifting Speed (ft/min)	Lifting Motor 3 Phase 60 Hz			Load Chain Diameter (mm) x Chain Fall Lines	Net Weight (lbs)	
				Output (Hp)	Rated Current (amps)			NER	ER
					@208 – 230V	@460V			
1/8	(N)ER001HCC	6	55	0.75	3.4	1.7	4.3 x 1	66	68
1/4	(N)ER003SCC	6	36	0.75	3.4	1.7	4.3 x 1	66	68

SINGLE SPEED DIMENSIONS

Cap. (Tons)	Product Code	Headroom C (in)	D (in)	a (in)		b (in)		d (in)		e (in)	f (in)		g (in)	h (in)	i (in)	
				NER	ER	NER	ER	NER	ER		NER	ER			NER	ER
1/8	(N)ER001HCC	41.9	19.3	18.8	22.2	12.6	13.6	8.6	12.0	10.2	10.2	11.2	1.1	3.9	3.7	4.6
1/4	(N)ER003SCC	41.9	19.3	18.8	22.2	12.6	13.6	8.6	12.0	10.2	10.2	11.2	1.1	3.9	3.7	4.6

NER/ER CYLINDER CONTROL — DUAL SPEED SPECIFICATIONS

Cap. (Tons)	Product Code	Standard Lift (ft)	Lifting Speed (ft/min)	Lifting Motor 3 Phase 60 Hz*			Load Chain Diameter (mm) x Chain Fall Lines	Net Weight (lbs)	
				Output (Hp)	Rated Current (amps)			NER	ER
					@208 – 230V	@460V			
1/8	(N)ER001HDCC	6	55/9	0.75	3.6	1.8	4.3 x 1	64	68
1/4	(N)ER003SDCC	6	36/6	0.75	3.6	1.8	4.3 x 1	64	68

*Although both 208/230 & 460 Volts are shown together, the motors are **NOT** reconnectable.
Speed ratio is 6:1 with adjustability up to 12:1.

DUAL SPEED DIMENSIONS

Cap. (Tons)	Product Code	Headroom C (in)	D (in)	a (in)		b (in)	d (in)		e (in)	f (in)	g (in)	h (in)	i (in)
				NER	ER		NER	ER					
1/8	(N)ER001HDCC	41.9	19.3	21.1	22.2	13.6	10.9	12.0	10.2	11.2	1.1	3.9	4.6
1/4	(N)ER003SDCC	41.9	19.3	21.1	22.2	13.6	10.9	12.0	10.2	11.2	1.1	3.9	4.6

SNER Electric Chain Hoists with Hook and Lug Suspensions and Motorized, Push and Geared Trolleys



SNER005L

Our SNER Series of electric chain hoists furnishes single-phase operation in a heavy-duty, low-headroom design. Available in hook mount or coupled with a trolley, it easily transports any load. Look to this model when high quality and convenience are important for the job.

Features and Benefits

Extreme Duty Motor

Higher horsepower and top duty ratings provide increased performance.

Pull-Rotor Motor Brake

Extremely durable and reliable, this advanced design has no brake coil to fail.

Unique Chain Guide

Provides quiet and smooth guiding of chain. Easily removed without disassembly of hoist. Heavy cast iron construction for improved wear.

Load Sheave

Deep-groove pockets fully support the load chain, reduces vibration and chain wear and provides a true vertical lift.

Long Life Friction Clutch

Protects hoist from damage and prevents overwinding.

Heat Treated Helical and Spur Gears

Precision machined for long life. Oil bath lubrication results in a quiet, smooth, cool operation.

Completely Sealed Body

Suitable for indoor, outdoor and harsh environments.

Compact Aluminum Body

Die-cast body is lightweight and offers low headroom.

Easy Maintenance Control Panel

Fast on-site access with hinged cover, single swing-out panel and simple layout of controls.

Superior Quality Chain

Grade 80 nickel-plated load chain is heat treated for wear resistance and extended life.

Forged Carbon Steel Hooks

Under excessive loads will open gradually and not fracture. Bottom hook swivels 360 degrees.

Motorized Trolley Side Guide Rollers

Provide smooth trolley motion and reduced wear on wheels and beam.

Motorized Trolley Drop Stops and Rubber Bumpers

Built-in security for the operator and added protection for the equipment and load.

Standard Hoist/Trolley Specifications

Capacity Range

1/4 Ton–3 Ton

Reconnectible Voltage

115/230-1-60

Control Voltage

110V

Duty Cycle*

Hoist—60 Min., Trolley—30 Min.

Classification*

ASME H4, ISO M5 or M4, FEM 2m or 1Am

Ratings

Hoist/Trolley—IP55

Pendant—IP65

Limit Switch

Prevents overwinding/overlifting
Standard upper

Chain Falls

Single fall through 2 Ton

Standard Lengths

Lift—10'

Pendant Drop—4' less than lift

Power Supply—Hoist—15'

Power Supply—Motorized

Trolley—30'

(longer lengths available)

Standard Pendants

Hoist—2 Button,

Hoist/Trolley—4 Button

Momentary contacts

Chain Containers

Optional

Canvas, plastic or steel

Geared Trolley Standard

Hand Chain Drop

2' less than lift

(longer drops available)

Trolley Shafts

Standard shafts fit wide flange range

Longer shafts for wider beams

Spacers for easy adjustments

Trolley Wheels

All steel

Shielded ball bearings

Fit flat or tapered beam flange

*See page 59 for additional information.



SNER005L

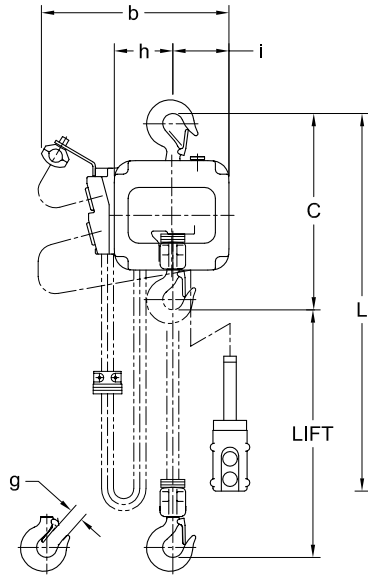

SNER005L

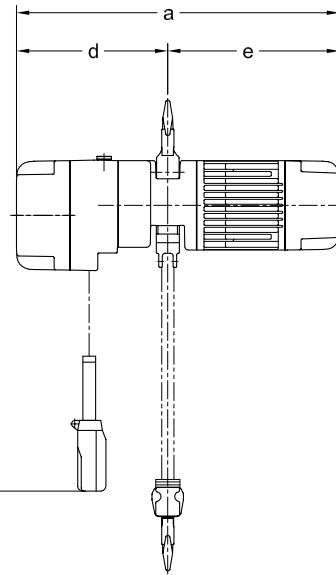

SINGLE SPEED—SPECIFICATIONS

Cap. (Tons)	Product Code	Standard Lift (ft)	Push Button Cord L (ft)	Lifting Speed (ft/min)	Lifting Motor Single Phase 60 Hz			Load Chain Diameter (mm) x Chain Fall Lines	Net Weight (lbs)	Weight for Additional One Foot of Lift (lbs)
					Output (Hp)	Rated Current (amps)				
						@115V	@230V			
1/4	SNER003S	10	7.2	14	0.34	7.7	3.9	5.0 x 1	82	0.37
1/2	SNER005L			7				6.3 x 1		
1/2	SNER005S			15	0.6	16.9	8.5	6.3 x 1	104	0.57
1	SNER010L			7				8.0 x 1		
1	SNER010S			14	8.0 x 1	159	0.93			
2	SNER020L			7	1.2			23.9	12.0	10.0 x 1
3	SNER030C			8.2	3.5	10.0 x 2	207			3.1

SINGLE SPEED—DIMENSIONS

Cap. (Tons)	Product Code	Headroom C (in)	a (in)	b (in)	d (in)	e (in)	g (in)	h (in)	i (in)
1/4	SNER003S	13.8	22.2	13.0	10.4	11.9	0.9	4.0	3.9
1/2	SNER005L	14.0	22.2	13.0	10.4	11.9	0.9	4.0	3.9
1/2	SNER005S	14.6	23.2	13.8	10.6	12.6	0.9	4.7	4.1
1	SNER010L	16.1	23.2	13.8	10.6	12.6	1.2	4.7	4.1
1	SNER010S	17.3	26.9	16.5	12.4	14.4	1.2	6.1	5.2
2	SNER020L	22.6	26.9	16.5	12.4	14.4	1.5	6.1	5.2
3	SNER030C	29.5	26.9	16.5	12.4	14.4	1.7	8.2	3.0

SNER Electric Chain Hoists with Hook and Lug Suspensions and Motorized, Push and Geared Trolleys



SNERM005L

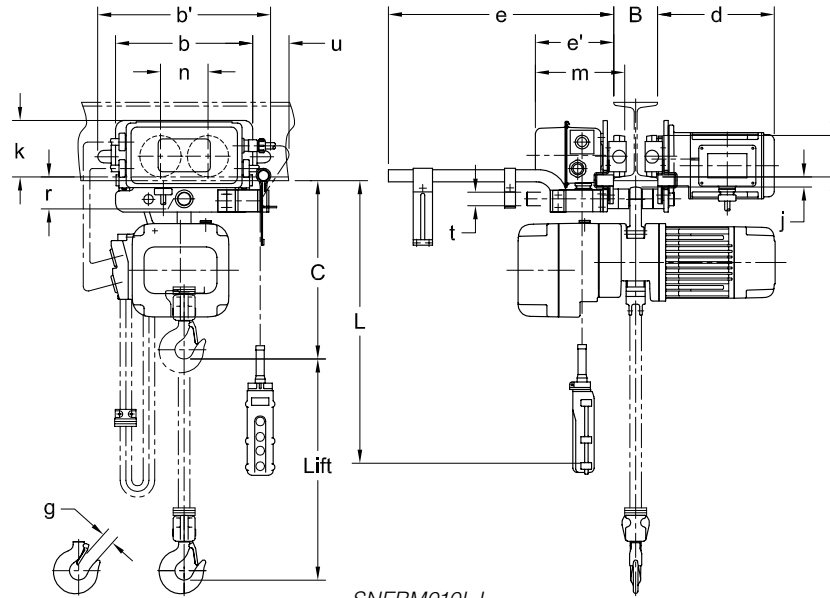

SNERM010L-L

SINGLE SPEED HOIST WITH SINGLE SPEED TROLLEY—SPECIFICATIONS

Cap. (Tons)	Product Code	Std. Lift (ft)	Push Button Cord L (ft)	Lifting Speed (ft/min)	Traversing Speed (ft/min)	Lifting Motor Single Phase 60 Hz			Traversing Motor Single Phase 60 Hz			Flange Width Adjustability B (in)		Min. Allow. Radius for curve (in)	Load Chain Dia. (mm) x Chain Fall Lines	Net Weight (lbs)	Weight for Additional One Foot of Lift (lbs)
						Output (Hp)	Rated Current (amps)		Output (Hp)	Rated Current (amps)		Standard	Optional				
							@ 115V	@ 230V		@ 115V	@ 230V						
1/4	SNERM003S-L/S	10	7.5	14	L = 40 S = 80	0.34	7.7	3.9	0.54	MPIA	MPIA	2.28 to 5.00	5.01 to 6.02 OR 6.03 to 12.00	31.5	5.0 x 1	168	0.37
1/2	SNERM005L-L/S			7											6.3 x 1	170	0.57
1/2	SNERM005S-L/S			15											6.3 x 1	190	0.57
1	SNERM010L-L/S			7		8.0 x 1	196	0.93									
1	SNERM010S-L/S			14		8.0 x 1	245	0.93									
2	SNERM020L-L/S			7		10.0 x 1	276	1.5									
3	SNERM030C-L/S			8.2		3.5	1.2	23.9		12.0	6.2				3.1	3.23 to 6.02	6.03 to 7.02 OR 7.03 to 12.00

SINGLE SPEED HOIST WITH SINGLE SPEED TROLLEY—DIMENSIONS

Cap. (Tons)	Product Code	Headroom C (in)	b (in)	b' (in)	d (in)	e (in)	e' (in)	g (in)	i (in)	j (in)	k (in)	m (in)	n (in)	r (in)	t (in)	u (in)
1/4	SNERM003S-L/S	14.6	12.4	15.6	10.6	20.3	7.0	0.9	3.74	0.9	5.1	8.0	4.3	2.0	1.22	3.2
1/2	SNERM005L-L/S	14.6	12.4	15.6	10.6	20.3	7.0	0.9	3.74	0.9	5.1	8.0	4.3	2.0	1.22	3.2
1/2	SNERM005S-L/S	15.4	12.4	15.6	10.6	20.3	7.0	0.9	3.74	0.9	5.1	8.0	4.3	2.0	1.22	3.2
1	SNERM010L-L/S	16.5	12.4	15.6	10.6	20.3	7.0	1.2	3.74	0.9	5.1	8.0	4.3	2.0	1.22	3.2
1	SNERM010S-L/S	17.7	12.4	15.6	10.6	20.3	7.0	1.2	3.74	0.9	5.1	8.0	4.3	2.0	1.22	3.2
2	SNERM020L-L/S	22.2	12.8	16.4	10.7	20.5	7.2	1.5	4.33	1.1	4.9	8.3	4.6	2.4	1.42	3.0
3	SNERM030C-L/S	28.9	13.4	17.4	10.8	20.5	7.3	1.7	4.92	1.1	5.2	8.5	5.2	2.7	1.69	2.7

HARRINGTON ELECTRIC CHAIN HOISTS

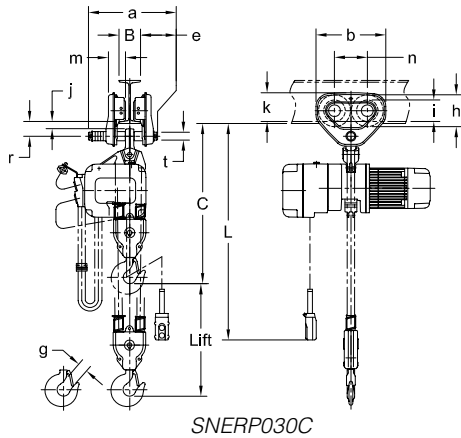

SNERP030C

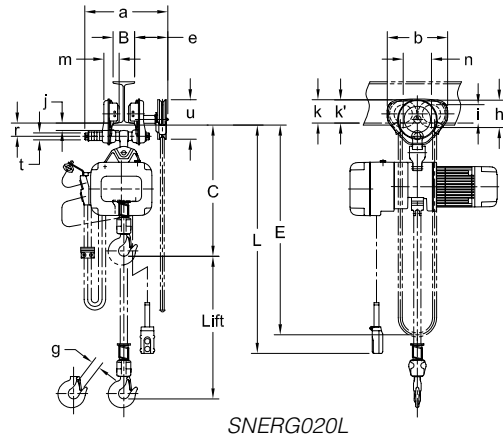

SNERG020L

SINGLE SPEED HOIST WITH PUSH OR GEARED TROLLEY—SPECIFICATIONS

Cap. (Tons)	Product Code	Std Lift (ft)	Push Button Cord L (ft)	Lifting Speed (ft/min)	Lifting Motor Single Phase 60 Hz			Flange Width Adjustability B (in)		Min.* Allow. Radius for curve (in)	Load Chain Dia. (mm) x Chain Fall Lines	Net Weight (lbs)	Weight for Additional One Foot of Lift (lbs)			
					Output (Hp)	Rated Current (amps)		Standard	Optional							
						@115V	@230V									
1/4	SNERP(SNERG)003S	10	7.5	14	0.34	7.7	3.9	2.28 to 4.00 (2.28 to 5.00)	4.01 to 8.00 (5.01 to 8.00) OR 8.01 to 12.00	43.3 (51.2)	5.0 x 1	93 (110)	0.37 (1.0)			
1/2	SNERP(SNERG)005L			7							0.6	16.9	8.5	2.28 to 5.00	5.01 to 8.00 OR 8.01 to 12.00	51.2
1/2	SNERP(SNERG)005S			15	6.3 x 1	115 (135)	0.57 (1.2)									
1	SNERP(SNERG)010L			7	1.2	23.9	12.0	3.23 to 6.02	6.03 to 12.00	59.1	8.0 x 1	130 (141)	0.93 (1.5)			
1	SNERP(SNERG)010S			14							8.0 x 1	179 (190)	0.93 (1.5)			
2	SNERP(SNERG)020L			7							10.0 x 1	209 (220)	1.5 (2.2)			
3	SNERP(SNERG)030C			8.2	3.5					66.9	10.0 x 2	251 (262)	3.1 (3.7)			

Figures in parentheses are data for geared trolley.

*Minimum flange width for curved beam: 1 Ton Push and 1/4 to 1 Ton Geared = 2.87 in.; 3 Ton Push or Geared = 3.50 in.

SINGLE SPEED HOIST WITH PUSH TROLLEY—DIMENSIONS

Cap. (Tons)	Product Code	Headroom C (in)	a (in)	b (in)	e (in)	g (in)	h (in)	i (in)	j (in)	k (in)	m (in)	n (in)	r (in)	t (in)
1/4	SNERP003S	15.4	8.0	7.2	1.8	0.9	3.2	2.36	0.7	3.0	1.9	3.3	1.5	0.87
1/2	SNERP005L	15.4	8.0	7.2	1.8	0.9	3.2	2.36	0.7	3.0	1.9	3.3	1.5	0.87
1/2	SNERP005S	16.1	8.0	7.2	1.8	0.9	3.2	2.36	0.7	3.0	1.9	3.3	1.5	0.87
1	SNERP010L	18.1	9.8	9.3	2.2	1.2	4.2	2.80	1.1	3.7	2.2	4.4	2.0	0.98
1	SNERP010S	19.5	9.8	9.3	2.2	1.2	4.2	2.80	1.1	3.7	2.2	4.4	2.0	0.98
2	SNERP020L	24.6	11.8	11.0	2.7	1.5	5.0	3.35	1.3	4.4	2.8	5.2	2.4	1.26
3	SNERP030C	29.3	12.6	12.8	3.1	1.7	5.8	3.94	1.4	5.3	3.1	6.0	2.7	1.42

SINGLE SPEED HOIST WITH GEARED TROLLEY—DIMENSIONS

Cap. (Tons)	Product Code	Headroom C (in)	E (ft)	a (in)	b (in)	e (in)	g (in)	h (in)	i (in)	j (in)	k (in)	k' (in)	m (in)	n (in)	r (in)	t (in)	u (in)
1/4	SNERG003S	16.1	10.5	13.6	9.3	6.0	0.9	4.2	2.80	1.1	3.7	4.2	2.2	4.4	2.0	0.98	7.2
1/2	SNERG005L	16.1	10.5	13.6	9.3	6.0	0.9	4.2	2.80	1.1	3.7	4.2	2.2	4.4	2.0	0.98	7.2
1/2	SNERG005S	16.9	10.5	13.6	9.3	6.0	0.9	4.2	2.80	1.1	3.7	4.2	2.2	4.4	2.0	0.98	7.2
1	SNERG010L	18.1	10.5	13.6	9.3	6.0	1.2	4.2	2.80	1.1	3.7	4.2	2.2	4.4	2.0	0.98	7.2
1	SNERG010S	19.5	10.5	13.6	9.3	6.0	1.2	4.2	2.80	1.1	3.7	4.2	2.2	4.4	2.0	0.98	7.2
2	SNERG020L	24.6	10.5	15.2	11.0	6.1	1.5	5.0	3.35	1.3	4.4	4.3	2.7	5.2	2.4	1.26	7.2
3	SNERG030C	29.3	11.0	15.7	12.8	6.2	1.7	5.8	3.94	1.4	5.3	4.5	3.1	6.0	2.7	1.42	7.2

ED Electric Chain Hoists with Hook Suspension and Mini Trolley



ED250DS

In our ED Series of electric chain hoists, we offer the user a powerful combination of benefits. A wide variety of lifting speeds. A low headroom designed to fit most applications. A unique, ergonomically designed, one-handed cylinder control that results in maximum load control. These features tied together with the convenience of single-phase power, make these hoists ideal for both commercial and industrial applications.

Features and Benefits

ALL MODELS

Double Braking System

Provides protection with a Weston-style mechanical load brake and a regenerative brake.

Compact Design

Die-cast aluminum body is lightweight and low headroom to fit into tight areas. Easy to install, move and store.

Heavy Duty Motor

With .4 to .8 horsepower is above standard for industrial situations. The compact DC motor with rectifier for AC current reduces weight, generates less heat and maintains duty cycles.

High Performance Friction Clutch

Is integrated with the load brake and designed to slip to prevent overwinding or overtravel.

Heat Treated Gearing

Deep-groove ball and needle bearings are immersed in an oil bath resulting in smooth, quiet operation.

UNIQUE TO DUAL SPEED (DS) MODEL

Speed Flexibility

Low speed adjustable from 0 to 100% of maximum speed by setting screw inside the pendant.

UNIQUE TO CYLINDER CONTROL (DA) MODEL

In-Line Handgrip

Permits one-handed operation and gives the operator a free hand to easily position the load.

Removable Bottom Hook

Permits insertion of a variety of below-the-hook material handling devices.

High/Low Speeds

Easy touch rocker switch above handgrip allows quick selection between low and high speed control. Finger turn knobs allow custom setting of speeds from 0-100%.

UNIQUE TO DUAL SPEED INFINITY (DSA) MODEL

Speed Adjustment

Pendant has external speed adjustment knobs to customize the high and low speeds.

Heavy Duty Metal Hinged Cover

Protects pendant knobs from damage and prevents speed settings from shifting during operation.

UNIQUE TO VARIABLE SINGLE SPEED (V) MODEL

Smart Speed Technology

Ability to increase factory set speed to a higher speed with a simple adjustment inside the hoist.

Standard Hoist Specifications

Capacity Range

125 lb.-1050 lb.

Voltage

120-1-60

Control Voltage

120V Direct

Duty Cycle*

Varies by capacity — see charts

Ratings

Hoist — IP54

Pendant — IP65

Cylinder Control — IP44

Limit Switch

Prevents overwinding/overlifting
Standard upper

Chain Falls

Single fall — 125-525 lb.

Double fall — 1000-1050 lb.

Standard Lengths

Single/Dual Speeds Lift — 10'

Cylinder Control Lift — 6'

Single/Dual Speeds Pendant

Drop — 3' less than lift

Cylinder Control — 9' reach
(approx.)

(reach equals lift plus headroom)

Power Supply — 16'

(longer lengths available)

Standard Pendants

Single/Dual Speeds — 2 button
Momentary contacts

Chain Containers

Standard

Plastic

Mini Trolley

Fits all ED models up
to 525 lb. capacity

For 1000 and 1050 lb. capacities
or wider flanges use PT005 trolley

*See page 59 for additional information.

HARRINGTON ELECTRIC CHAIN HOISTS



ED525DA

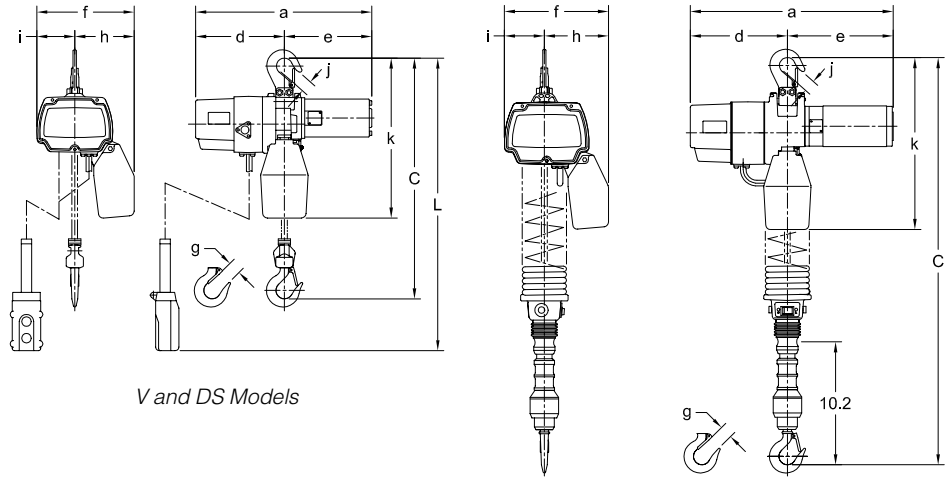

V and DS Models

DA Model
(Dimensions in inches.)

HOIST—SPECIFICATIONS

Cap. (lbs)	Product Code			Lifting Speed (ft/min)			Standard Lift (ft)		Push Button Cord L (ft)		Motor Output (Hp)	Intermittent Duty Rating		Short Time Duty Rating (min)	Lifting Motor 1 Phase 60 Hz Rated Current at 120V (amps)
	Variable Single Speed (V) Model	Dual Speed (DS) Model	Dual Adjustable (DA) Model	V Model*		DS & DA Model	V & DS Model	DA Model	V & DS Model	DA Model		Duty Rating % ED	Max. Start Freq. (times/hr)		
				Std.	Max. Adj.										
125	-	ED125DS	ED125DA	-	-	69/13	10	6	8	Coiled	0.4	30	180	15	5
220	-	ED220DS	ED220DA	-	-	43/10	10	6	8	Coiled	0.4	30	180	15	5
250	-	ED250DS	ED250DA	-	-	26/10	10	6	8	Coiled	0.4	20	120	10	6
250	ED250V	-	-	16	26	-	10	-	8	-	0.4	20	120	10	6
350	-	ED350DS	ED350DA	-	-	66/13	10	6	8	Coiled	0.8	30	180	20	10
350	ED350V	-	-	16	44	66/13	10	-	8	-	0.8	30	180	20	10
400	-	ED400DS	ED400DA	-	-	26/10	10	6	8	Coiled	0.4	20	120	10	6
500	ED500V	-	-	16	44	-	10	-	8	-	0.8	30	180	20	10
525	-	ED525DS	ED525DA	-	-	44/10	10	6	8	Coiled	0.8	30	180	20	10
1000	ED1000V	-	-	8	22	-	10	-	8	-	0.8	30	180	20	10
1050	-	ED1050DS	-	-	-	22/6	10	-	8	-	0.8	30	180	15	10

*The V Model is Factory set at the "Std" speed. It can be adjusted up to the "Max. Adj." speed.

HOIST—DIMENSIONS AND WEIGHTS

Cap. (lbs)	Headroom C (in)		a (in)	d (in)	e (in)	f (in)	g (in)	h (in)	i (in)	j (in)	k (in)	Net Weight (lbs)			Weight for Additional One Foot of Lift (lbs)	
	V & DS Model	DA Model										V Model	DS Model	DA Model	V Model	DS Model
125	12.4	37.2	14.6	7.4	7.2	8.1	1	4.9	3.1	1	13.4	23	24	31	0.26	0.29
220	12.4	37.2	14.6	7.4	7.2	8.1	1	4.9	3.1	1	13.4	23	24	31	0.26	0.29
250	12.4	37.2	14.6	7.4	7.2	8.1	1	4.9	3.1	1	13.4	24	25	32	0.26	0.29
250	12.4	-	14.6	7.4	7.2	8.1	1	4.9	3.1	1	13.4	24	-	-	0.26	-
350	13	37.8	16.9	8.1	8.8	8.6	1	5.3	3.3	1	14.3	33	34	40	0.26	0.29
350	13	-	16.9	8.1	8.8	8.6	1	5.3	3.3	1	14.3	33	-	-	0.26	-
400	12.4	37.2	14.6	7.4	7.2	8.1	1	4.9	3.1	1	13.4	24	25	32	0.26	0.29
500	13	-	16.9	8.1	8.8	8.6	1	5.3	3.3	1	14.3	33	-	-	0.26	-
525	13	37.8	16.9	8.1	8.8	8.6	1	5.3	3.3	1	14.3	33	34	40	0.26	0.29
1000	20.5	-	16.9	8.1	8.8	9	0.9	6.1	2.9	1	17.9	46	-	-	0.49	-
1050	20.5	-	16.9	8.1	8.8	9	0.9	6.1	2.9	1	17.9	46	47	-	0.49	0.52

ED Electric Chain Hoists with Hook Suspension and Mini Trolley



ED525DSA

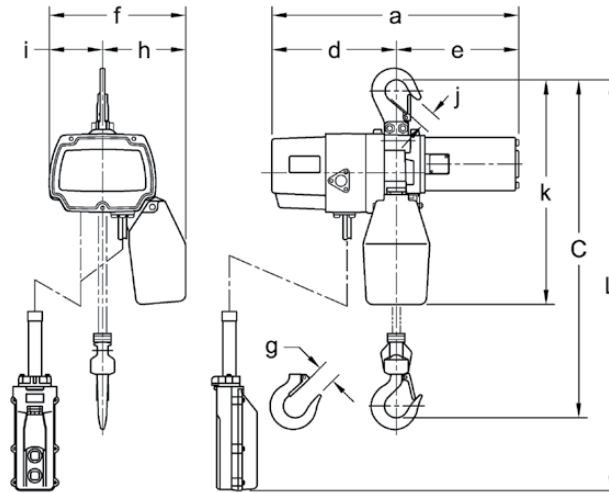

ED525DSA

HOIST—DIMENSIONS AND WEIGHTS

Cap. (lbs)	Product Code	Lifting Speed (ft/min)	Standard Lift (ft)	Push Button Cord L (ft)	Motor Output (HP)	Intermittent Duty Rating		Short Time Duty Rating (min)	Rated Current at 120V (amps)
						Duty Rating % ED	Max. Start Freq. (Times/Hr)		
125	ED125DSA	69/13	10	8	0.4	30	180	15	5
220	ED220DSA	43/10			0.4	30	180	15	5
250	ED250DSA	26/10			0.4	20	120	10	6
350	ED350DSA	66/13			0.8	30	180	20	10
400	ED400DSA	26/10			0.4	20	120	10	6
525	ED525DSA	44/10			0.8	30	180	20	10
1050	ED1050DSA	22/6			0.8	30	180	15	10

HOIST—DIMENSIONS AND WEIGHTS

Cap. (lbs)	Headroom C (in)	a (in)	d (in)	e (in)	f (in)	g (in)	h (in)	i (in)	j (in)	k (in)	Net Weight (lbs)	Weight for Additional One Foot of Lift (lbs)
125	12.4	14.6	7.4	7.2	8.1	1.0	4.9	3.1	1.0	13.4	24	0.29
220	12.4	14.6	7.4	7.2	8.1		4.9	3.1		13.4	24	
250	12.4	14.6	7.4	7.2	8.1		4.9	3.1		13.4	25	
350	13.0	16.9	8.1	8.8	8.6		5.3	3.3		14.3	34	
400	12.4	14.6	7.4	7.2	8.1		4.9	3.1		13.4	25	
525	13.0	16.9	8.1	8.8	8.6		5.3	3.3		14.3	34	
1050	20.5	16.9	8.1	8.8	9.0		0.9	6.1		2.9	17.9	47

ED Electric Chain Hoists



ET525

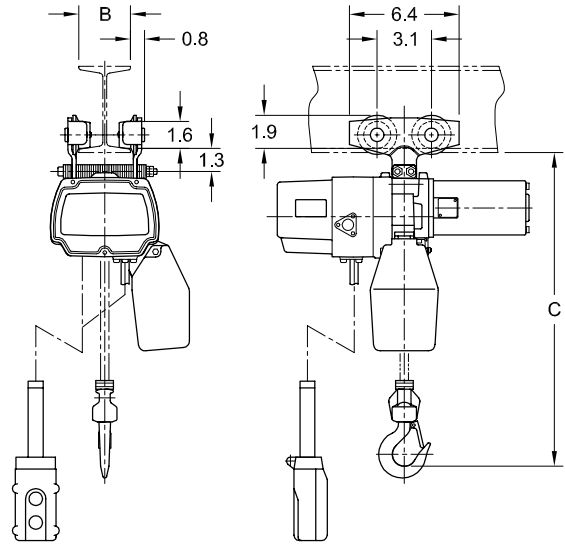

ET525 (Dimensions in inches.)

ET MINI TROLLEY—SPECIFICATIONS

Maximum Capacity (lbs)	Product Code	Adjustable Beam Width B (in)	Minimum Radius For Curve (in)	Net Weight (lbs)	Approximate Shipping Weight (lbs)
525	ET525	1.97-3.94	23.6	4.0	5.0

ET MINI TROLLEY—DIMENSIONS

Cap. (lbs)	Headroom C (in)	
	V, DS, DSA Models	DA Model
125	10.6	35.4
220		
250		
350	11.6	36.0
400	10.0	35.4
525	11.6	36.0

Options and Technical Data

LOAD LIMITER

Reduces the potential for making hazardous, over-capacity lifts. The load limiter is preset at 115% of rated capacity and protects the hoist mechanism from damage due to overloading. Overloading the hoist electrically activates the load limiter, making the hoist inoperable (load can still be lowered at any time).



STEEL CHAIN CONTAINERS



Containers are installed differently depending on the type of product or lift. The steel containers may not cover the standard beam curve radii depending on their installation conditions.

BULLARD® AND SHUR-LOC® HOOKS

These hooks offer a positive locking latch feature. Consult Customer Service for full details.



Bullard®



Shur-Loc®

PENDANT COVER

Pliable silicone rubber pendant cover designed to protect hoist and trolley push button pendants.



Options and Technical Data

VARIABLE FREQUENCY DRIVE – VFD (INVERTER FOR SMOOTH TRANSITIONAL SPEED)

The dual speed inverter delivers smoother movement than contactor control which reduces load swing. The inverter can be programmed to operate specific to the application resulting in smooth starts, improved control, improved positioning accuracy and overall increased productivity. Standard lifting speed ratio for 1/8 Ton through 5 Ton is 6:1 adjustable to 12:1* Standard lifting speed ratio for 8 Ton and larger capacities is 3:1 adjustable to 12:1* Standard traversing speed ratio is 6:1 adjustable to 10:1.

(N)ER/MR inverter unit is well-customized for lifting/traversing applications including exclusive software and is also provided with measures against impact and heat which were verified through long-run tests.

**For a speed ratio other than the standard 2-speed or to request 2-step or 3-step infinitely variable, please make the request at the time of placing an order.*

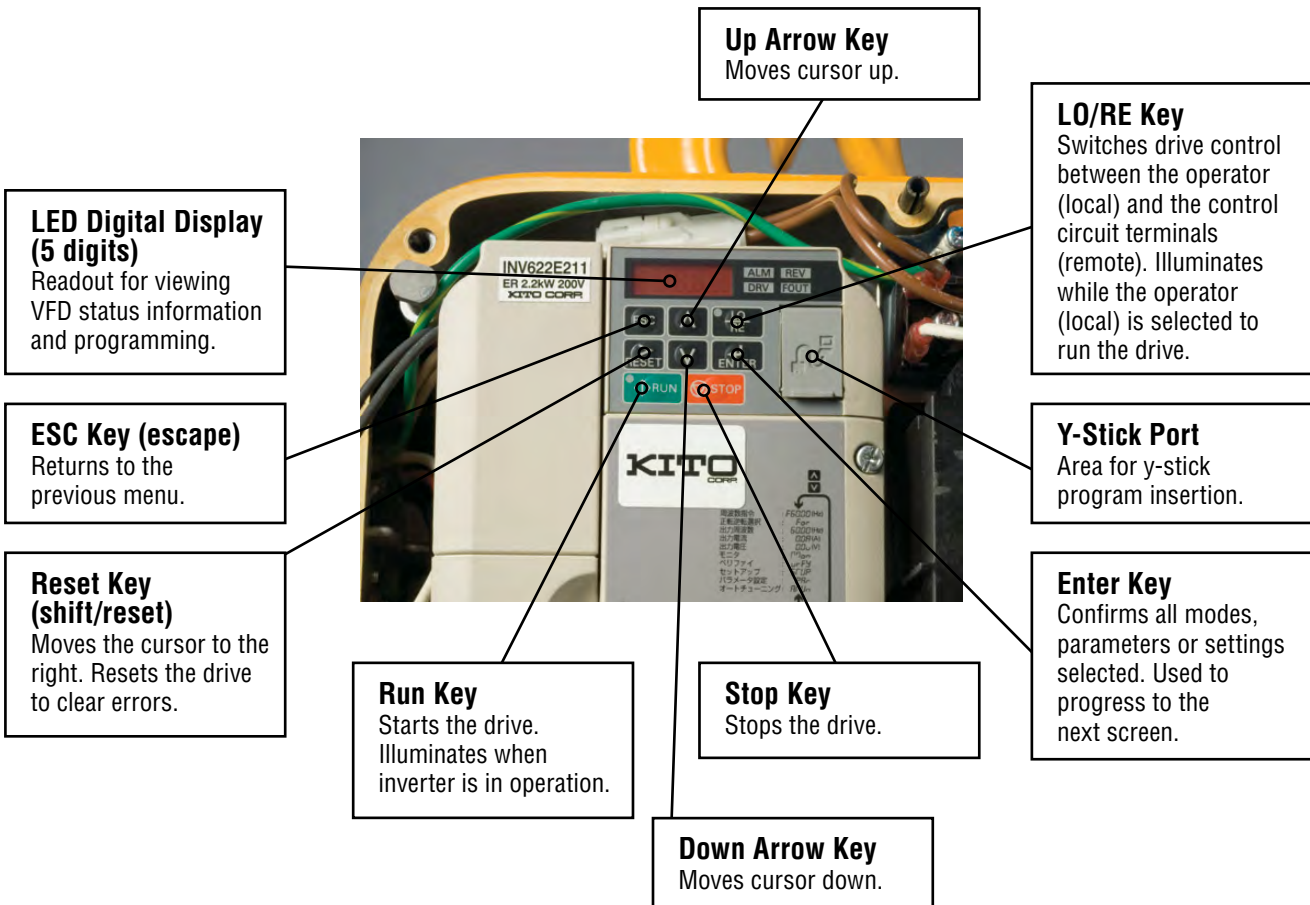

UL Standards
The UL mark applied to products in the United States indicates that UL has performed product testing and evaluation and determined that their stringent standards for product safety have been met. For a product to receive UL certification, all components inside that product must also receive UL certification.

In general terms, with some exceptions, standard configurations of Harrington NER/ER three phase electric chain hoists qualify for UL. Custom configurations do not qualify. Examples of some product configurations that do not qualify include the addition of radio remote control, a load limiter, Bullard® hooks, flat cable festooning and cylinder control models.

SPEED COMPARISONS

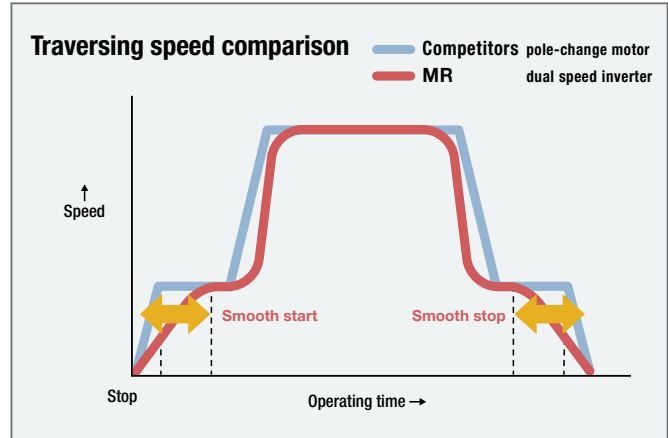
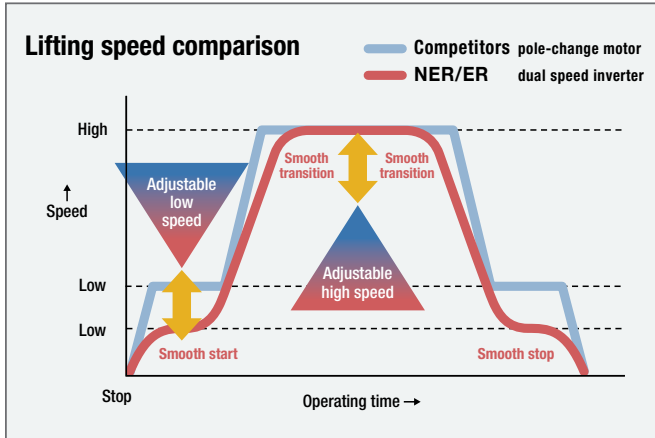

VFD HOIST CONTROL DESCRIPTIONS

Dual Speed Control

Uses a 2-step button and a VFD to control the speed. Pressing the button to the first step causes the hoist to accelerate smoothly to the low speed. Pressing the button to the second step causes the hoist to accelerate smoothly to the high speed. Releasing the button from the second step to the first step causes the hoist to smoothly decelerate to the low speed. Releasing the button completely from any step causes the hoist to decelerate quickly to a stop with the brake holding the load.

2-Step Infinitely Variable Control

Uses a 2-step button and a VFD to control the speed. The acceleration rate can be changed by changing parameters in the VFD. The 2-Step Infinitely Variable differs from Dual Speed Control in that when releasing the button from the second step to the first step it will maintain whatever the speed was at the instant before the button arrived at the first step. This allows you to hold any speed between the low and the high speed. If the hoist is operating at a speed that is less than high speed, and you wish it to operate at a faster speed, press the button to the second step to accelerate the hoist. When you reach the desired speed, release the button to the first step. Note that there is no deceleration function other than completely releasing the button.

3-Step Infinitely Variable Control

Uses a 3-step button and a VFD to control the speed. This control is similar to the 2-Step Infinitely Variable Control with the added feature of a deceleration function. If the hoist is operating at a particular speed and you wish it to operate at a faster speed, press the button to the third step to accelerate. When you reach the desired speed, release the button to the second step to maintain that speed. If the hoist is operating at a particular speed and you want it to operate at a slower speed, release the button to the first step to decelerate. When you reach the desired speed, press the button to the second step to maintain that speed.

Contact Customer Service for additional documentation and descriptions.

“THE GUARDIAN”: SMART BRAKE TECHNOLOGY—DESCRIPTION

The Guardian Smart Brake releases when it senses current being consumed by the motor. If the motor burns out OR is single-phased, the motor does not consume current (amps). This cuts power to the brake and the brake assembly locks. It is electrically failsafe by design. The brake does not need adjustment or replacement parts, and it carries a **10 year warranty**.



Options and Technical Data

(N)ER CHAIN—DIMENSIONS

Cap. (Tons)	Product Code	d (in)	a (in)	b (in)	P (in)
1/8	(N)ER001HCC(D)	0.17	0.26	0.59	0.48
1/8	(N)ER001H(D)	0.17	0.26	0.59	0.48
1/4	(N)ER003S(D)	0.17	0.26	0.59	0.48
1/4	(N)ER003SCC(D)	0.17	0.26	0.59	0.48
1/4	(N)ER003H(D)	0.24	0.35	0.83	0.66
1/2	(N)ER005L(D)	0.24	0.35	0.83	0.66
1/2	(N)ER005S(D)	0.24	0.35	0.83	0.66
1	(N)ER010L(D)	0.30	0.46	1.06	0.85
1	(N)ER010S(D)	0.30	0.46	1.06	0.85
1 1/2	(N)ER015S(D)	0.40	0.60	1.41	1.13
2	(N)ER020C(D)	0.30	0.46	1.06	0.85
2	(N)ER020L(D)	0.40	0.60	1.41	1.13
2	(N)ER020S(D)	0.40	0.60	1.41	1.13
2 1/2	(N)ER025S(D)	0.44	0.65	1.54	1.24
3	(N)ER030L(D)*	0.49	0.62	1.73	1.50
3	(N)ER030C(D)	0.40	0.60	1.41	1.13
5	(N)ER050L(D)	0.44	0.65	1.54	1.24
8	(N)ER080S(D)	0.44	0.65	1.54	1.24
10	(N)ER100L(D)	0.44	0.65	1.54	1.24
10	(N)ER100S(D)	0.44	0.65	1.54	1.24
15	(N)ER150S(D)	0.44	0.65	1.54	1.24
20	(N)ER200S(D)	0.44	0.65	1.54	1.24

*The (N)ER030L(D) listed is the previous hoist model.

SNER CHAIN—DIMENSIONS

Cap. (Tons)	Product Code	d (in)	a (in)	b (in)	P (in)
1/4	SNER003S	0.20	0.25	0.71	0.59
1/2	SNER005L	0.25	0.31	0.87	0.75
1/2	SNER005S	0.25	0.31	0.87	0.75
1	SNER010L	0.31	0.39	1.10	0.94
1	SNER010S	0.31	0.39	1.10	0.94
2	SNER020L	0.39	0.49	1.38	1.18
3	SNER030C	0.39	0.49	1.38	1.18

ED CHAIN—DIMENSIONS

Cap. (lbs)	Product Code	d (in)	a (in)	b (in)	P (in)
125 to 1050	(All Models)	0.16	0.20	0.53	0.48

(N)ER HOOK—DIMENSIONS

Product Code	Hook**	a (in)	b (in)	c (in)	d (in)	e (in)	f (in)	g (in)	h (in)
(N)ER001H, 003S, 003H, 005L, 005S	T & B	1.1	0.7	0.9	0.7	1.4	1.5	1.1	3.7
(N)ER001HCC, 003SCC	T	1.1	0.7	0.9	0.7	1.4	1.5	1.1	3.7
	B	0.8	0.5	0.7	0.5	1.4	1.4	0.9	3.0
(N)ER010L, 010S	T & B	1.5	0.9	1.2	0.9	1.7	1.8	1.2	4.3
(N)ER020C	T & B	1.9	1.1	1.6	1.1	2.0	2.2	1.5	5.4
(N)ER015S	T	2.0	1.3	1.7	1.3	2.1	2.2	1.5	5.7
	B	1.7	1.1	1.5	1.1	1.9	2.0	1.4	4.9
(N)ER020L, 020S	T & B	2.0	1.3	1.7	1.3	2.1	2.2	1.6	5.7
(N)ER025S	T	2.0	1.3	1.7	1.3	2.4	2.4	1.7	6.1
	B	2.0	1.3	1.7	1.3	2.1	2.2	1.6	5.7
(N)ER030L*, 030C	T & B	2.2	1.4	1.9	1.4	2.4	2.5	1.8	6.3
(N)ER050L	T & B	2.6	1.7	2.2	1.7	2.5	2.9	1.9	7.4
(N)ER080S	B	3.3	2.2	2.9	1.9	3.3	3.7	2.5	9.5
(N)ER100L, 100S	T & B	4.1	2.8	3.4	2.4	3.9	4.3	3.2	11.4
(N)ER150S	T & B	4.6	3.3	3.9	2.8	4.3	4.9	3.4	12.3
(N)ER200S	T & B	5.2	3.3	4.4	2.8	4.9	5.6	4.1	14.4

*The (N)ER030L listed is the previous hoist model.

**T = top hook, B = bottom hook

SNER* HOOK—DIMENSIONS

Capacity Code	Hook*	a (in)	b (in)	c (in)	d (in)	e (in)	f (in)	g (in)	h (in)
003, 005L, 005S	T	1.1	0.7	0.9	0.7	1.4	1.5	1.1	3.5
	B	1.1	0.7	0.9	0.7	1.4	1.5	0.9	3.4
010L, 010S	T & B	1.4	0.9	1.2	0.9	1.7	1.8	1.2	4.2
020L	T & B	1.9	1.1	1.6	1.1	2.0	2.2	1.5	5.3
030C	T & B	2.2	1.4	1.9	1.4	2.4	2.5	1.7	6.3

*T=top hook, B=bottom hook.

ED HOOK—DIMENSIONS

Capacity Code	Hook*	a (in)	b (in)	c (in)	d (in)	e (in)	f (in)	g (in)	h (in)
125 – 525	T	0.8	0.3	0.7	0.3	1.3	1.2	1.0	2.9
	B	0.8	0.5	0.7	0.5	1.4	1.4	1.0	3.0
1000 – 1050	T	1.1	0.7	0.9	0.7	1.4	1.2	1.1	3.5
	B	1.1	0.7	0.9	0.7	1.4	1.4	0.9	3.4

*T=top hook, B=bottom hook.

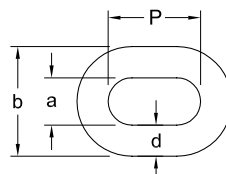

Chain Dimensions

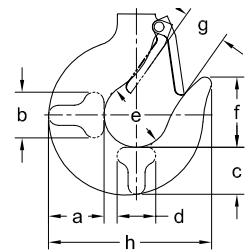

Hook Dimensions

**CORROSION-RESISTANT CHAINS
NICKEL-PLATED (NP)**

Examples of Corrosion Resistance to Acids, Salts, and Other Substances Under Normal Temperatures

Substance		Concentration %	Corrosion Resistance
Air	Indoors, Outdoors	—	No Corrosion
Mineral Acids	Sulfuric Acid	10	Corrosion
	Nitric Acid	10	Corrosion
	Hydrochloric Acid	10	Corrosion
	Phosphoric Acid	10	Slight Corrosion
	Boric Acid	5	Slight Corrosion
Organic Acids	Acetic Acid	10	Slight Corrosion
	Tartaric Acid	10	No Corrosion
Alkalis	Caustic Soda	10	No Corrosion
	Ammonia	10	Slight Corrosion
Other	Salt Water	—	Slight Corrosion

Results listed in this table are for chemicals in a pure state. The degree of corrosion resistance may differ from this table with the presence of other chemicals, different concentrations, mixed substances or damage to the nickel surface layer.

UNIVERSAL LATCH KITS

Generic design to fit most hooks. Available in standard steel or stainless steel. Neck and throat dimensions can be combined for proper fit. (Example, neck size E with throat size L.) Neck measurement must be diameter—not circumference. Contact Customer Service for dimensions not shown.

Latch Kit Product Code	Neck Diameter N (in)	Throat Opening T (in)
A	9/16 to 5/8	1 1/16 to 1 1/8
B	3/4 to 1 3/16	1 1/4
C	7/8 to 1	1 3/8 to 1 1/2
D	1 1/8 to 1 1/4	1 3/4 to 1 7/8
E	1 3/8 to 1 1/2	2 1/16
F	1 5/8 to 1 1/16	2 1/4
G	1 3/4 to 1 13/16	2 1/2
H	1 7/8 to 2	3
J	2 1/16 to 2 1/8	3 3/8
K	2 3/16 to 2 1/4	3 1/2
L	2 5/16 to 2 3/8	3 3/4
M	2 7/16 to 2 3/4	4
O	3 to 3 1/4	4 1/2

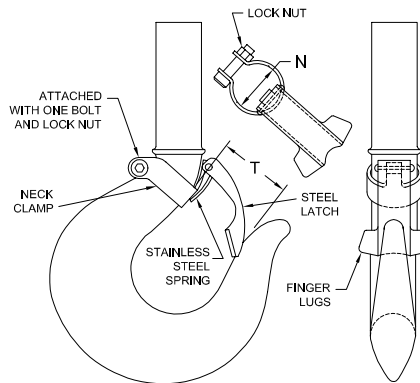

Options and Technical Data

DUTY CLASSIFICATIONS

Hoist Duty Class	Typical Areas of Application	Operation Time Ratings at K = 0.65*			
		Uniformly Distributed Work Periods		Infrequent Work Periods	
		Max. Time (min/hr)	Max. No. of Starts/hr	Max. Time From Cold Start (min)	Max. No. of starts
H2	Light machine shop fabricating, service and maintenance; loads and utilization randomly distributed; rated loads infrequently handled	7.5 (12.5%)	75	15	100
H3	General machine shop fabricating, assembly, storage, and warehousing; loads and utilization randomly distributed	15 (25%)	150	30	200
H4	High volume handling in steel warehouses, machine shops, fabricating plants and mills, and foundries; manual or automatic cycling operations in heat treating and plating; loads at or near rated load frequently handled	30 (50%)	300	30	300

*K = Mean effective load factor.

State of Loading		Total duration of use (hr)						
		200	400	800	1600	3200	6300	12500
Light	Mechanisms subjected very rarely to the maximum load and, normally, to light loads	-	-	M1	M2	M3	M4	M5
Moderate	Mechanisms subjected fairly frequently to the maximum load and, normally, to rather moderate loads	-	M1	M2	M3	M4	M5	M6
Heavy	Mechanisms subjected frequently to the maximum load and, normally, to loads of heavy magnitude	M1	M2	M3	M4	M5	M6	-
Very Heavy	Mechanisms subjected regularly to the maximum load	M2	M3	M4	M5	M6	-	-

This classification refers to ISO 4301-1 and applies to the mechanical components including gears and bearings except for consumable parts.

COMPLIANCE

Harrington's electric chain hoists are produced to comply with:

- UL 1340*
- ANSI/NFPA 70, "National Electrical Code"
- ANSI/ASME B30.16, "Safety Standard—Overhead Hoists (Underhung)"
- ANSI/ASME HST—1M, "Performance Standard for Electric Chain Hoists"

Harrington's manual and electric-powered trolleys are produced to comply with the trolley-related requirements of:

- OSHA Section 1910.179 of Title 29, "Occupational Safety and Health Regulations—Overhead and Gantry Cranes"
- ANSI/ASME B30.11, "Safety Standard—Monorails and Underhung Cranes"
- ANSI/ASME B30.17, "Safety Standard—Overhead and Gantry Cranes (Top Running Bridge, Single Girder, Underhung Hoist)"

*Most models shipped with UL listing. Contact Customer Service for listed models.

LIFTING MOTOR RATINGS

Short Time Rating

This rating indicates how long the hoist can be operated continuously at the rated capacity on the cycle below, assuming continued operation for a short time span.

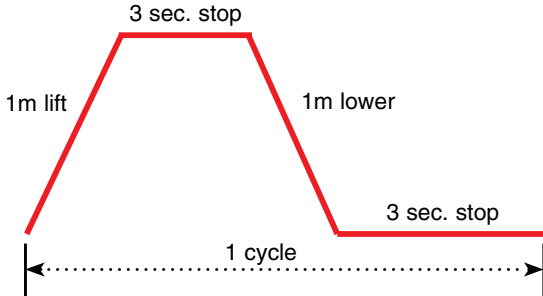

- Single speed: 60 min
- Dual speed: 30/10 min

Intermittent Rating (Percent ED)

Max. Number of Starts Per Hour

This rating indicates the allowable ratio of motor ON time to motor OFF time, and starts per hour for a hoist operated continuously at 63% of rated capacity on the cycle below, assuming continued operation or repeated starting over a long time span.

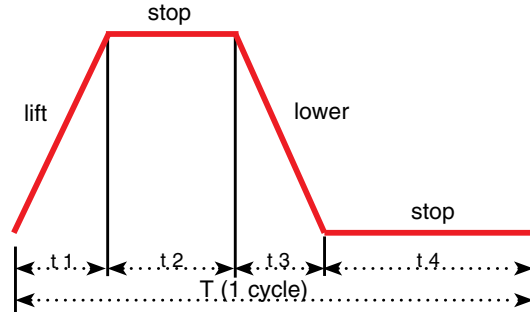

Example (single speed): %ED = $\frac{\text{Motor ON time } (t1 + t3)}{T \text{ (1 cycle)}} \times 100$

(Where T = 1 cycle (t1 + t2 + t3 + t4) and is not more than 10 minutes.)

NER/ER Lifting Motor Ratings

- Single speed: 60% ED, 360 starts/hr
- Dual speed: 40/20% ED, 120/240 starts/hr

**Product Code
For NER/ER Series**

ERM 020 SD-SD

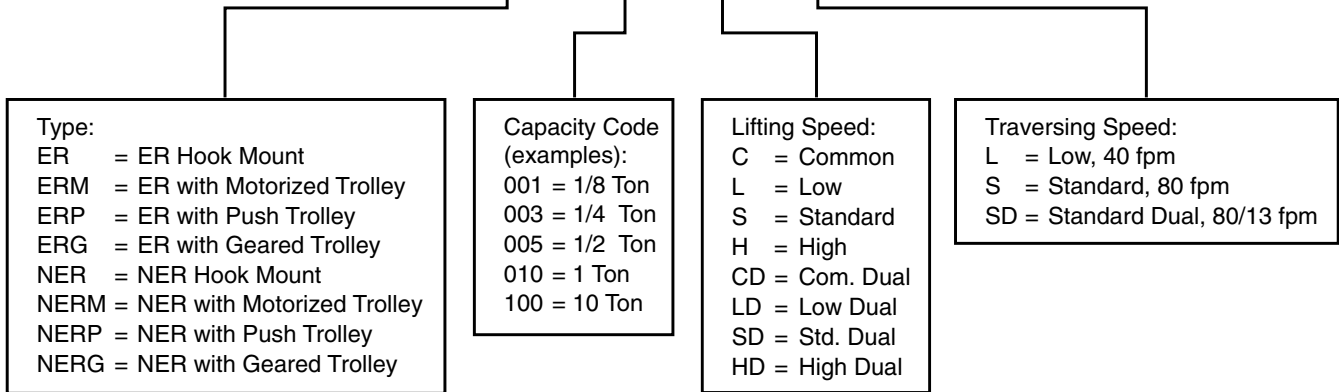

Product Specification Form

Harrington Three Phase Electric Chain Hoists

NER/ER THREE-PHASE ELECTRIC CHAIN HOISTS/TROLLEYS

Quantity _____
 Capacity _____
 Lift _____
 Lift Speed _____ C (Common) _____ L (Low)
 _____ S (Standard) _____ H (High)
 _____ Single _____ Dual
 Voltage _____ 208-3-60 _____ 230-3-60 _____ 460-3-60 _____ 575-3-60
 Control Voltage _____ 110V (standard) _____ 24V
 Control _____ Pendant
 Pendant Drop _____ (standard is 4' less than lift)
 Power Supply Cord _____
 (standard is 15' thru 5 Ton – hook, push or geared trolley mount)
 (standard is 30' above 5 Ton – hook, push or geared trolley mount)
 (standard is 30' all capacities – motorized trolley mount)
 Suspension _____ Hook _____ Lug _____ Trolley (see below)

Options: _____ Canvas Chain Container
 _____ Steel Chain Container
 _____ Plastic Chain Container
 _____ Mechanical Brake (ER standard feature)
 _____ Hoist Mount – Parallel to Beam
 _____ Hoist Mount – Perpendicular to Beam

Trolley Type _____ Push _____ Geared _____ Motorized
 Hand Chain Drop _____ (if geared trolley)
 Travel Speed _____ L (40 FPM) _____ S (80 FPM) _____
 _____ SD (80/13 FPM) (if motorized trolley)
 Beam Type/Size _____
 Beam Flange Width _____
 Beam Radius _____ (if curved monorail)

Specials: _____

Form completed by:

Name _____ Company _____

Phone _____ Fax _____

Address _____ City _____ State _____ Zip _____

E-Mail Address _____ Copy & fax to 717-665-7432

Notes

Complete Product Offering

Over the years Harrington has continued to respond to the needs of our customers by further expanding our product offerings. In addition to the many models described in this catalog, our full series of product catalogs, as shown below, will provide you with all of the information you will need to answer questions, specify a product and place an order. For catalog copies or answers to specific product questions, please contact our Customer Service Department by calling 800-233-3010 or e-mail customerservice@harringtonhoists.com

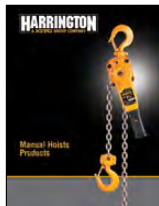

Manual Hoist Products Catalog

Refer to this Harrington catalog for detailed information on the following:

- Lever hoists
- Hand chain hoists
- Hoist and trolley combinations
- Low headroom trolley hoists
- Push and geared trolleys
- Hoist load testers



Air Powered Hoists Catalog

Refer to this Harrington catalog for detailed information on the following:

- Compact Mini-Cat with pendant, cord and manipulator controls
- Air hoists with pendant and cord controls
- Air trolleys



Electric Wire Rope Hoists Catalog

Refer to this Harrington catalog for detailed information on the following:

- Ultra-low headroom trolley hoists



Crane Components Catalog

Refer to this Harrington catalog for detailed information on the following:

- End trucks-top running-motorized, geared and push
- End trucks-underhung-motorized, geared and push
- Double girder MAX-E-Lift end trucks
- Convertible push end trucks
- Beam accessory kits



Complete Cranes Catalog

Refer to this Harrington catalog for detailed information on the following:

- Heavy-duty Class C single girder top running and underhung cranes
- Heavy-duty Class C double girder top running and underhung cranes
- Medium-duty top running and underhung push cranes
- Crane control panels



Below-The-Hook and Material Handling Equipment

Refer to this Harrington catalog for detailed information on the following:

- Lifting beams and spreader beams
- Roll lifters, coil lifters and tongs
- Sheet lifters and pallet lifters
- Fork truck accessories
- Material stands and material baskets

CONTACT YOUR NEARBY HARRINGTON DISTRIBUTOR

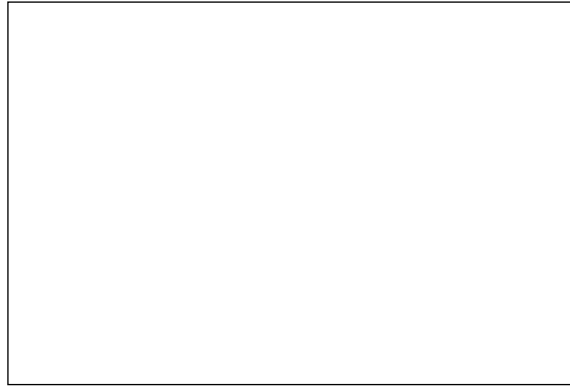

Warranty

All products sold by Harrington Hoists, Inc. are warranted to be free from defects in material and workmanship from date of shipment by Harrington for the following periods:

1 year—Electric and Air Powered Hoists (excluding (N)ER2 Enhanced Features Models, EQ/SEQ Hoists), Powered Trolleys, Powered Tiger Track Jibs and Gantries, Crane Components, Spare/Replacement Parts, Below-The-Hook and Material Handling Equipment

2 years—Manual Hoists & Trolleys, Beam Clamps

3 years—(N)ER2 Enhanced Features Model Hoists, EQ/SEQ Hoists, RY Wire Rope Trolley Hoists

5 years—Manual Tiger Track Jibs and Gantries, TNER and EQ/SEQ Pull-Rotor Motor Brakes and RY Motor Brakes

10 years—(N)ER2 “The Guardian” Smart Brake

The product must be used in accordance with manufacturer’s recommendations and must not have been subject to abuse, lack of maintenance, misuse, negligence, or unauthorized repairs or alterations.

Should any defect in material or workmanship occur during the above time period in any product, as determined by Harrington Hoist’s inspection of the product, Harrington Hoists, Inc. agrees, at its discretion, either to replace (not including installation) or repair the part or product free of charge and deliver said item F.O.B. Harrington Hoists, Inc. place of business to customer.

Customer must obtain a Return Goods Authorization as directed by Harrington or Harrington’s published repair center prior to shipping product for warranty evaluation. An explanation of the complaint must accompany the product. Product must be returned freight prepaid. Upon repair, the product will be covered for the remainder of the original warranty period. Replacement parts installed after the original warranty period will only be eligible for replacement (not including installation) for a period of one year from the installation date. If it is determined there is no defect, or that the defect resulted from causes not within the scope of Harrington’s warranty, the customer will be responsible for the costs of returning the product.

Harrington Hoists, Inc. disclaims any and all other warranties of any kind expressed or implied as to the product’s merchantability or fitness for a particular application. Harrington will not be liable for death, injuries to persons or property or for incidental, contingent, special or consequential damages, loss or expense arising in connection with the use or inability whatever, regardless of whether damage, loss or expense results from any act or failure to act by Harrington, whether negligent or willful, or from any other reason.

Harrington Hoists, Inc.
401 West End Avenue
Manheim, PA 17545



Toll Free: 800-233-3010
Phone: 717-665-2000
Fax: 717-665-2861

