Owner's Manual

ELECTRIC CHAIN HOIST ED SERIES

EDV

250 through 1000 Lb. Capacity

Code, Lot and Serial Number

⚠ WARNING

This equipment should not be installed, operated or maintained by any person who has not read and understood all the contents of this manual. Failure to read and comply with the contents of this manual can result in serious bodily injury or death, and/or property damage.

HARRINGTON
A KITO GROUP COMPANY



Table of Contents

Section	Page Number
1.0 Important Information and Warnings	4
1.1 Terms and Summary	
1.2 Warning Tags and Labels	
2.0 Technical Information.....	8
2.1 Specifications	
2.2 Dimensions	
2.3 Part Names	
3.0 Pre-operational Procedures	14
3.1 Fill Gear Box with Oil	
3.2 Chain	
3.3 Load Chain Lubrication	
3.4 Chain Container	
3.5 Mounting Location	
3.6 Mounting the Hoist	
3.7 Electrical Connections	
3.8 Mini Trolley Installation	
3.9 Pre-operational Checks and Trial Operation	
4.0 Operation	21
4.1 Introduction	
4.2 Shall's and Shall Not's for Operation	
4.3 Hoist Controls	
4.4 Electric Chain Hoist with Trolley	
4.5 Lifting Speed Adjustment Using Potentiometer	

Section	Page Number
5.0	Inspection 26
5.1	General
5.2	Inspection Classification
5.3	Frequent Inspection
5.4	Periodic Inspection
5.5	Occasionally Used Hoists
5.6	Inspection Records
5.7	Inspection Methods and Criteria
6.0	Maintenance & Handling 33
6.1	Lubrication
6.2	Load Chain
6.3	Mechanical Load Brake with Friction Clutch
6.4	Fuses
6.5	Storage
6.6	Outdoor Installation
7.0	Troubleshooting 36
8.0	Warranty 39
9.0	Parts List 40

1.0 Important Information and Warnings

1.1 Terms and Summary

This manual provides important information for personnel involved with the installation, operation and maintenance of this product. Although you may be familiar with this or similar equipment, it is strongly recommended that you read this manual before installing, operating or maintaining the product.

Danger, Warning, Caution and Notice

Throughout this manual there are steps and procedures that can present hazardous situations. The following signal words are used to identify the degree or level of hazard seriousness.

⚠ DANGER Danger indicates an imminently hazardous situation which, if not avoided, **will** result in **death or serious injury**, and property damage.

⚠ WARNING Warning indicates an imminently hazardous situation which, if not avoided, **could** result in **death or serious injury**, and property damage.

⚠ CAUTION Caution indicates a potentially hazardous situation which, if not avoided, **may** result **minor or moderate injury** or property damage.

NOTICE Notice is used to notify people of installation, operation, or maintenance information which is important but not directly hazard-related.

⚠ CAUTION

These general instructions deal with the normal installation, operation, and maintenance situations encountered with the equipment described herein. The instructions should not be interpreted to anticipate every possible contingency or to anticipate the final system, crane, or configuration that uses this equipment. For systems using the equipment covered by this manual, the supplier and owner of the system are responsible for the system's compliance with all applicable industry standards, and with all applicable federal, state and local regulations/codes.

This manual includes instructions and parts information for a variety of hoist types. Therefore, all instructions and parts information may not apply to any one type or size of specific hoist. Disregard those portions of the instructions that do not apply.

Record your hoist's Code, Lot and Serial Number (see Section 9) on the front cover of this manual for identification and future reference to avoid referring to the wrong manual for information or instructions on installation, operation, inspection, maintenance, or parts.

Use only Harrington authorized replacement parts in the service and maintenance of this hoist.

WARNING

Equipment described herein is not designed for and **MUST NOT** be used for lifting, supporting, or transporting people, or for lifting or supporting loads over people.

Equipment described herein should not be used in conjunction with other equipment unless necessary and/or required safety devices applicable to the system, crane, or application are installed by the system designer, system manufacturer, crane manufacturer, installer, or user.

Modifications to upgrade, rerate, or otherwise alter this equipment shall be authorized only by the original equipment manufacturer.

Equipment described herein may be used in the design and manufacture of cranes or monorails. Additional equipment or devices may be required for the crane and monorail to comply with applicable crane design and safety standards. The crane designer, crane manufacturer, or user is responsible to furnish these additional items for compliance. Refer to ANSI/ASME B30.17, "Safety Standard for Top-Running Single Girder Cranes"; ANSI/ASME B30.2 "Safety Standard for Top-Running Double-Girder Cranes"; and ANSI/ASME B30.11 "Safety Standard for Underhung Cranes and Monorails".

If a below-the-hook lifting device or sling is used with a hoist, refer to ANSI/ASME B30.9, "Safety Standard for Slings" or ANSI/ASME B30.20, "Safety Standard for Below-the-Hook Lifting Devices".

Hoists and cranes, used to handle hot molten material may require additional equipment or devices. Refer to ANSI Z241.2, "Safety Requirements for Melting and Pouring of Metals in the Metalcasting Industry".

Electrical equipment described herein is designed and built in compliance with Harrington's interpretation of ANSI/NFPA 70, "National Electrical Code". The system designer, system manufacturer, crane designer, crane manufacturer, installer, or user is responsible to assure that the installation and associated wiring of these electrical components is in compliance with ANSI/NFPA 70, and all applicable Federal, State and Local Codes.

Failure to read and comply with any one of the limitations noted herein can result in serious bodily injury or death, and/or property damage.

DANGER

HAZARDOUS VOLTAGES ARE PRESENT IN THE CONTROL BOX, OTHER ELECTRICAL COMPONENTS, AND CONNECTIONS BETWEEN THESE COMPONENTS.

Before performing ANY mechanical or electrical maintenance on the equipment, de-energize (disconnect) the main switch supplying power to the equipment; and lock and tag the main switch in the de-energized position. Refer to ANSI Z244.1, "Personnel Protection – Lockout/Tagout of Energy Sources".

Only trained and competent personnel should inspect and repair this equipment.

NOTICE

It is the responsibility of the owner/user to install, inspect, test, maintain, and operate a hoist in accordance with ANSI/ASME B30.16, "Safety Standard for Overhead Hoists", OSHA Regulations and ANSI/NFPA 70, National Electric Code. If the hoist is installed as part of a total lifting system, such as an overhead crane or monorail, it is also the responsibility of the owner/user to comply with the applicable ANSI/ASME B30 volume that addresses that type of equipment.

It is the responsibility of the owner/user to have all personnel that will install, inspect, test, maintain, and operate a hoist read the contents of this manual and applicable portions of ANSI/ASME B30.16, "Safety Standard for Overhead Hoists", OSHA Regulations and ANSI/NFPA 70, "National Electric Code". If the hoist is installed as part of a total lifting system, such as an overhead crane, the applicable ANSI/ASME B30 volume that addresses that type of equipment must also be read by all personnel.

If the hoist owner/user requires additional information, or if any information in the manual is not clear, contact Harrington or the distributor of the hoist. Do not install, inspect, test, maintain, or operate this hoist unless this information is fully understood.

A regular schedule of inspection of the hoist in accordance with the requirements of ANSI/ASME B30.16 should be established and records maintained.

1.2 Warning Tags and Labels

The warning tag illustrated below in Figure 1-1 is supplied with each hoist shipped from the factory. If the tag is not attached to your hoist's pendant cord or cylinder control, order a tag from your dealer and install it. Read and obey all warnings attached to this hoist. Tag is not shown actual size.

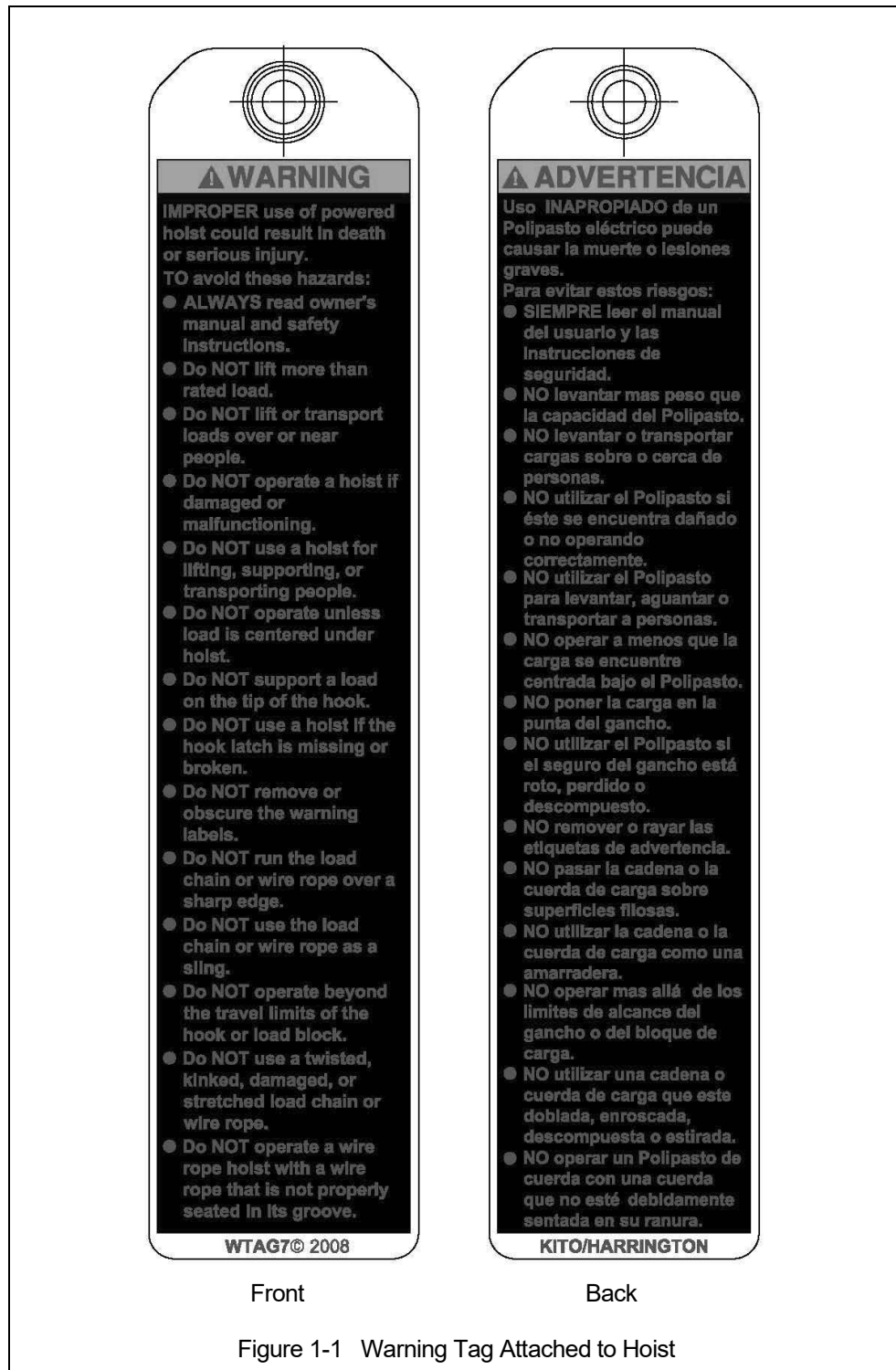
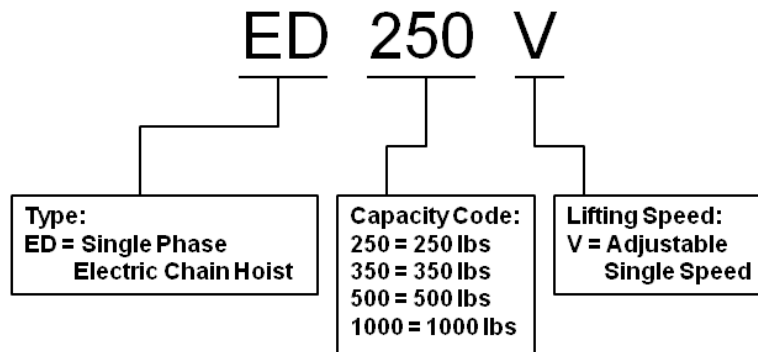

Figure 1-1 Warning Tag Attached to Hoist

2.0 Technical Information

2.1 Specifications

2.1.1 Product Code



2.1.2 Features and General Specifications

- Push Button Pendant Control – Standard
 - Weight/Size – Light weight and compact size, easy to install, move, or store
- Double Braking System – A Weston style load brake and a regenerative brake
- Low Headroom – Die cast aluminum body provides low headroom, perfect for tight quarters
- Upper Limit Switch – Standard
- Over-Travel Protection – Friction clutch integrated with load brake and engineered to protect the hoist from overwinding
- Smooth Operation – Gears are immersed in an oil bath and have deep groove ball and needle bearings to support rotating components
- Corrosion Resistant Load Chain – Nickel-plated, heat treated alloy chain for long life
- Chain Container – Standard

2.0.1 Operating Conditions and Environment

- Temperature range: -4° to +104°F (-20° to +40°C)
- Humidity: 85% or less
- Noise Level: 83 dB or less (A scale: measured 1 meter away from electric chain hoist)
- Enclosure Rating: Hoist Body IP54
Push Button Pendant IP65
- Supply Voltage: Standard 120V-1-60
- ASME Duty Classification: H2

Cap. (lbs.)	Product Code	Lifting Speed (ft/min)	Lifting Speed (maximum, ft/min)	Load Chain Wire Diameter (mm) x Chain Fall Lines	Load Sheave Pockets	Standard Lift (ft)	Push Button Cord L (ft)	Motor Output (HP)	Intermittent Duty Rating		Short Time Duty Rating (min)	Rated Current at 120V (amps)
									Duty Rating % ED	Max. Start Freq. (Times/Hr)		
250	ED250V	16	26	4.0 x 1	4	10	8	0.4	20	120	10	6
350	ED350V	16	44		5			0.8	30	180	20	10
500	ED500V	16	44					0.8	30	180	20	10
1000	ED1000V	8	22	4.0 x 2	0.8			30	180	20	10	

2.2 Dimensions

Cap. (lbs)	Headroom C (in)	a (in)	d (in)	e (in)	f (in)	g (in)	h (in)	i (in)	j (in)	k (in)	Net Weight (lbs)	Weight for Additional One Foot of Lift (lbs)
250	12.4	14.6	7.4	7.2	8.1	1.0	4.9	3.1	1.0	13.4	24	0.26
350	13.0	16.9	8.1	8.8	8.6		5.3	3.3				
500	13.0	16.9	8.1	8.8	8.6		5.3	3.3				
1000	20.5	16.9	8.1	8.8	9.0	1.1	6.1	2.9		17.9	46	0.49

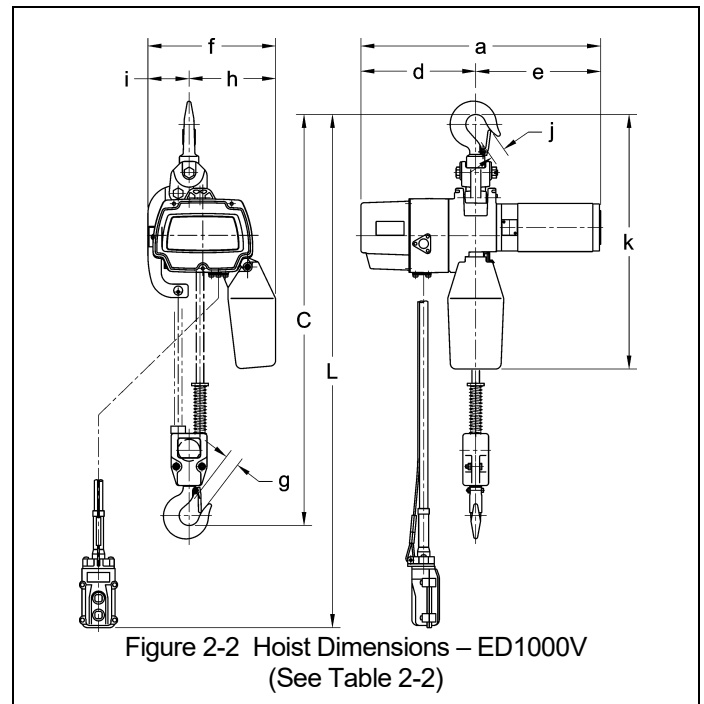
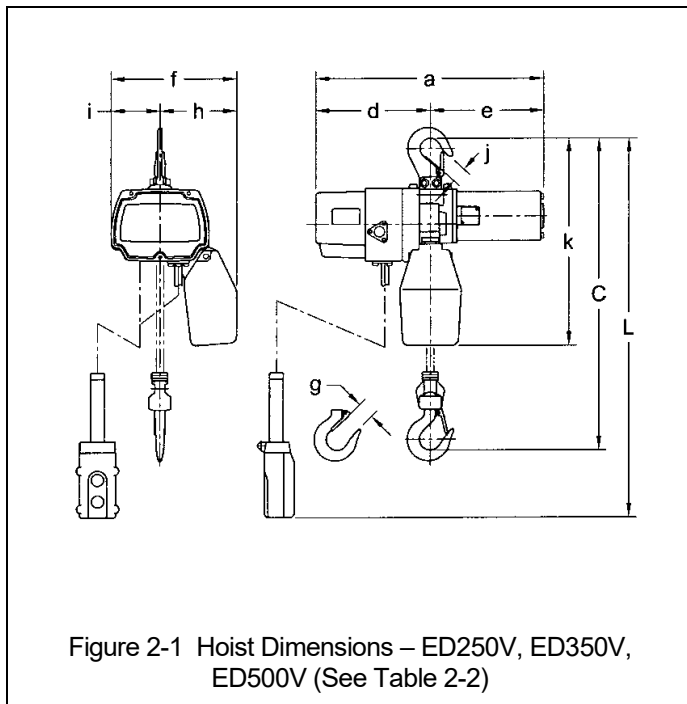

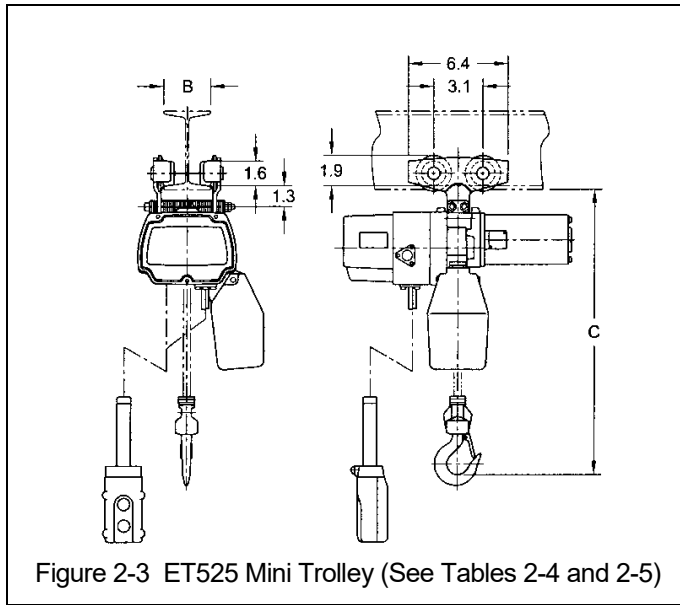

Maximum Capacity (lbs.)	Product Code	Beam Flange Width Range, B (in)	Minimum Radius for Curve(in)	Net Weight (lbs.)	Approximate Shipping Weight (lbs.)
500	ET525	1.97 – 3.94	23.6	4.0	5.0

Capacity (lbs.)	Headroom C (in.)
250	10.5
350	11.1
500	

Table 2-6 ED Hook Dimensions*								
Capacity (lbs.)	Hook	a (in)	b (in)	c (in)	d (in)	e (in)	f (in)	g (in)
250 to 500	Top	0.8	0.3	0.7	0.3	1.3	1.2	1.0
	Bottom	0.8	0.5	0.7	0.5	1.4	1.4	1.0
1000	Top	1.1	0.7	0.9	0.7	1.4	1.2	1.1
	Bottom	1.1	0.7	0.9	0.7	1.4	1.4	1.1

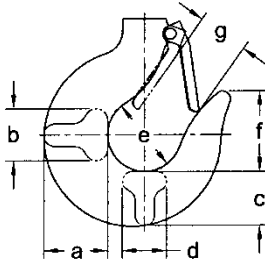

*See Table 5-5 in for discard dimensions.

Table 2-7 ED Chain Dimensions					
Cap. (lbs)	Product Code	d (in)	a (in)	b (in)	P (in)
250 to 1000	(All Models)	0.16	0.20	0.53	0.48

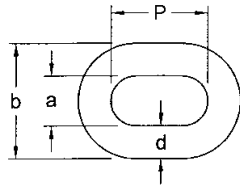

2.3 Part Names

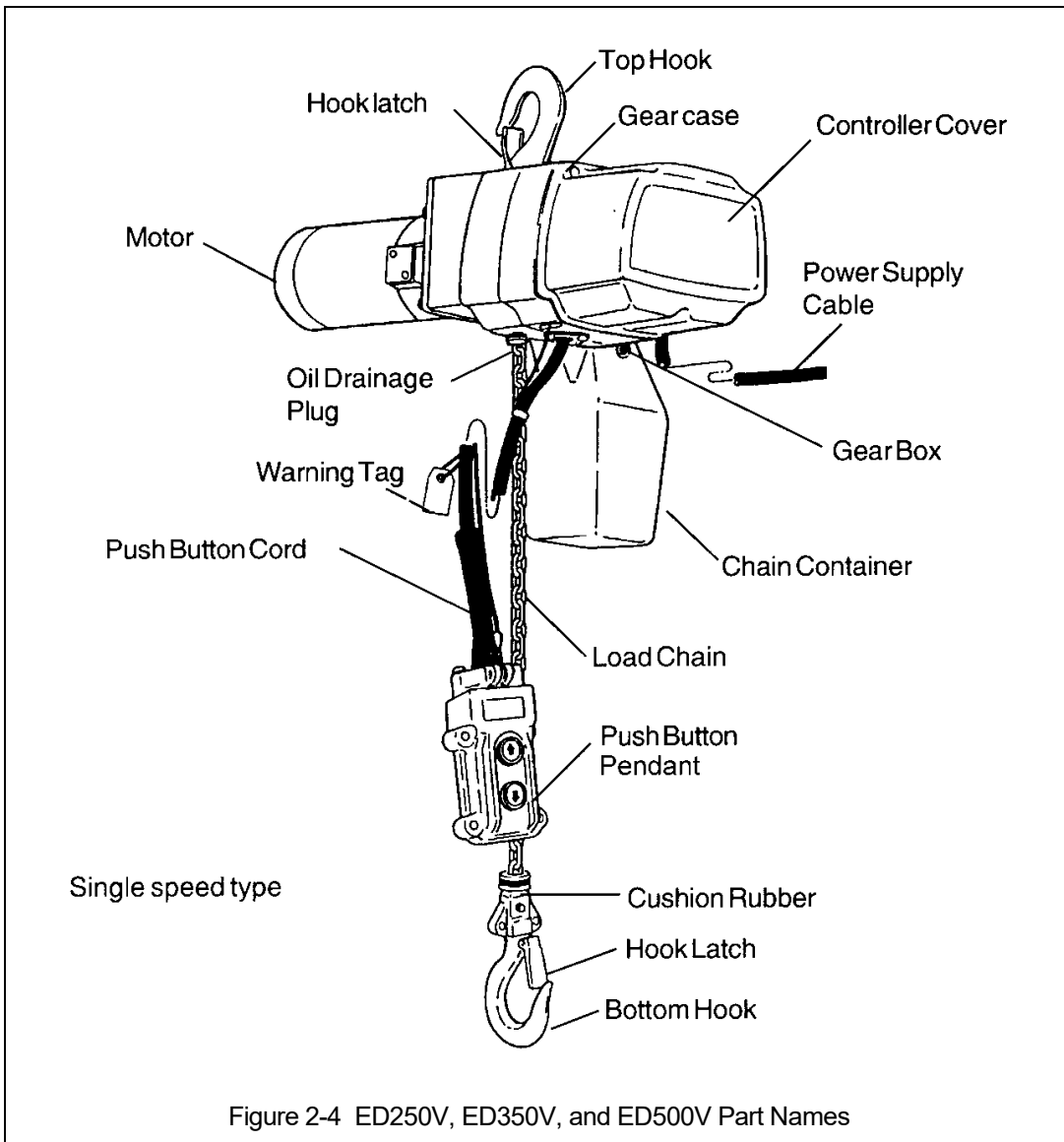

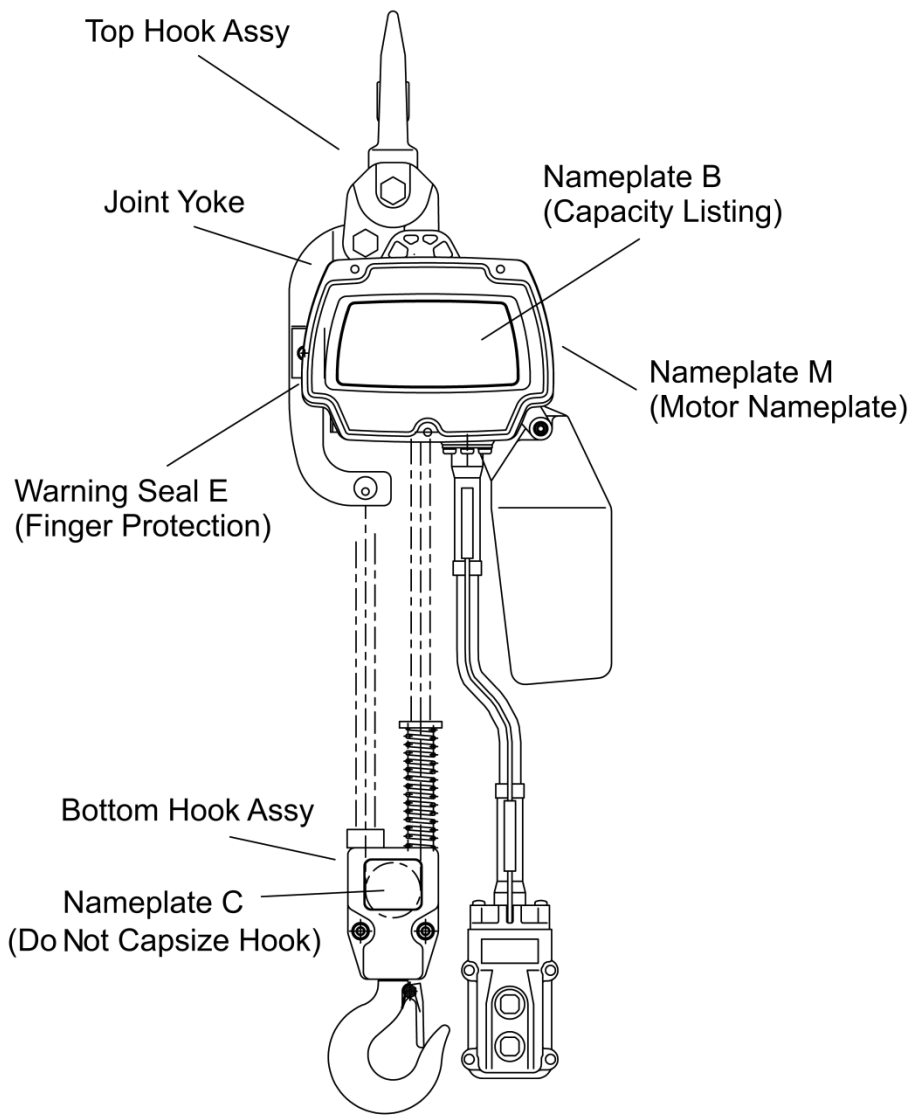

Figure 2-4 ED1000V Part Names

3.0 Pre-operational Procedures

3.1 Fill Gear Box with Oil

- 3.1.1 **⚠ CAUTION** Use only Harrington ED brand oil. The oil is specially blended and should be purchased from Harrington. Refer to parts list for part number.
- 3.1.2 For a new hoist the correct quantity and type of oil is pre-supplied in the gearbox.
- 3.1.3 Refer to Section 6.1 when replacing the gear oil or checking the gear oil level.

Capacity Code	quarts	liters
250	0.28	0.27
350	0.37	0.35
500		
1000		

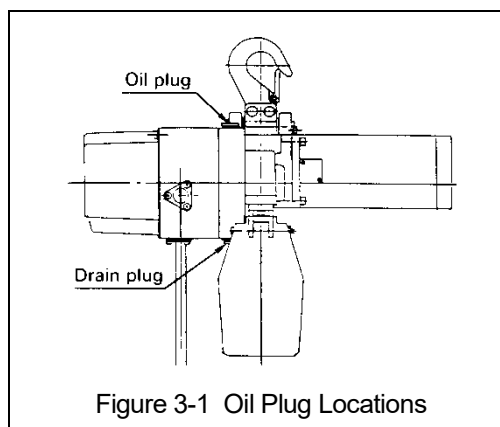

3.2 Chain

- 3.2.1 The quantity and location of the chain components including Cushion Rubbers, Washers and Stopper Assemblies depend on the hoist model, capacity. Never operate the hoist with incorrect, missing or damaged chain components. Refer to the hoist's nameplate, Table 3-2, and Figure 3-2 and ensure that all chain components are in the correct location and properly installed.

Capacity Code	Load Side	No Load Side
250, 350, 500, 1000	Adjacent to bottom yoke	Last link

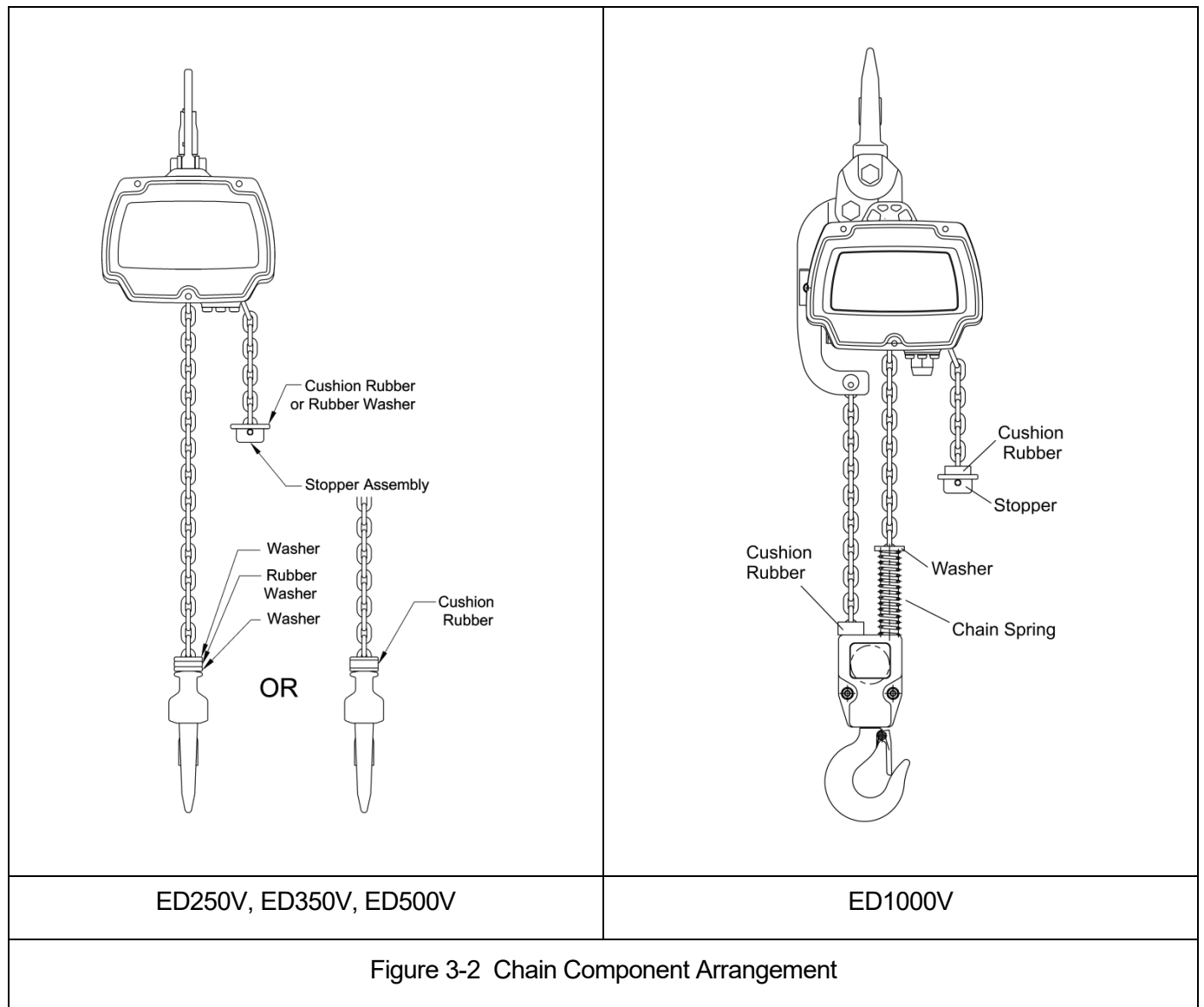

3.3 Load Chain Lubrication

3.3.1 Always lubricate load chain weekly, or more frequently, depending on severity of service.

3.3.2 **⚠️ WARNING** Always make sure to apply ISO VG 46 or 48 or equivalent machine oil. Insufficient oil lubrication will accelerate Load Chain wear.

3.4 Chain Container

3.4.1 Follow the instructions below to install the Chain Container. Refer to Figure 3-3.

- 1) Feed the Load Chain into the Chain Container beginning with the no-load end. Take care to avoid twisting or tangling the Load Chain.
- 2) Attach the Chain Container to the Chain Guide (1) with the Socket Bolt (2) and the U-Nut (3).
- 3) Attach the Split Pin (4) to prevent the U-Nut (3) from backing off.
- 4) Bend the Split Pin ends 90° or more.
- 5) **⚠ CAUTION** Do not use the Chain Container if any parts are damaged or if any fasteners/hardware are missing.

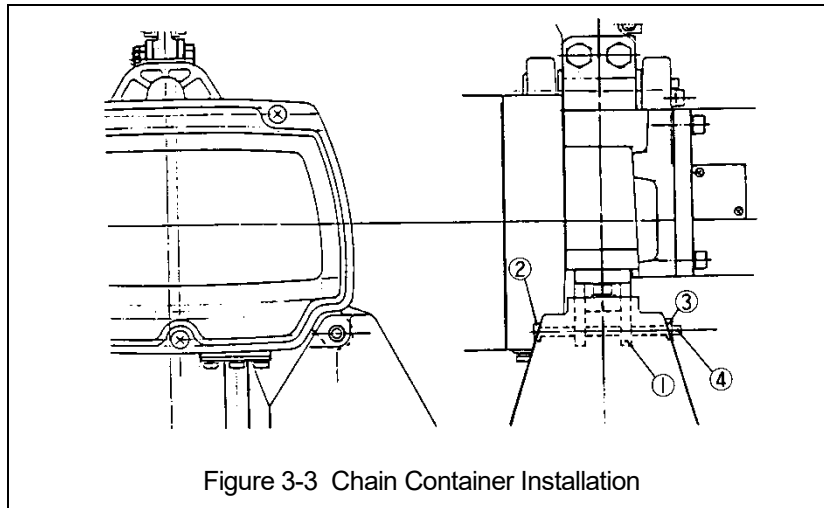

3.5 Mounting Location

3.5.1 **⚠ WARNING** Prior to mounting the hoist ensure that the suspension and the supporting structure are adequate to support the hoist and its loads. If necessary consult a professional that is qualified to evaluate the adequacy of the suspension location and its supporting structure.

3.5.2 **NOTICE** See Section 6.6 for outdoor installation considerations

3.6 Mounting the Hoist

3.6.1 ET525 Mini Trolley – Refer to Section 3.8 for installation instructions

3.6.2 Manual Trolley - Follow instructions in Owner's Manual provided with the trolley.

3.6.3 Hook Mounted to a Fixed Location - Attach the hoist's top hook to the fixed suspension point.

3.6.4 **⚠ WARNING** Ensure that the fixed suspension point rests on the center of the hook's saddle and the hook's latch is engaged.

3.7 Electrical Connections

3.7.1 **⚠ CAUTION** Ensure that the voltage of the electric power supply is proper for the hoist or trolley.

3.7.2 **⚠ DANGER** Before proceeding, ensure that the electrical supply for the hoist or trolley has been de-energized (disconnected). Lock out and tag out in accordance with ANSI Z244.1 "Personnel Protection -Lockout/Tagout of Energy Sources".

- 3.7.3 This instruction applies to installations where the hoist is installed hook mounted to a fixed suspension point or installed on a manual trolley. In this case the hoist is controlled by a pendant with two push buttons – one for raising and one for lowering.

Pendant Cord

The Pendant Cord is hard wired to the hoist. Make this connection as follows:

- 1.) Single Speed Adjustable Models (EDV)
 - Refer to Figure 3-4.
 - The Push Button Cord is factory installed onto the hoist body.
 - Attach the Strain Relief Wire (2) to Cable Support L (1).
- 2.) **⚠ WARNING** Short circuit and electric shock may result if the Push Button Cord is pulled when the Strain Relief Wire is not connected to the hoist body. ALWAYS make sure that the Strain Relief Wire is properly attached to the hoist body.
- 3.) **⚠ WARNING** To avoid wear between the Load Chain and the Chain Guide, straighten Load Chain before fitting the Coiled Cord to the Chain Container.
- 4.) **⚠ WARNING** To avoid damaging the Coiled Cord, attach the Chain Container so that the Wire Tie faces up and away from the Load Chain

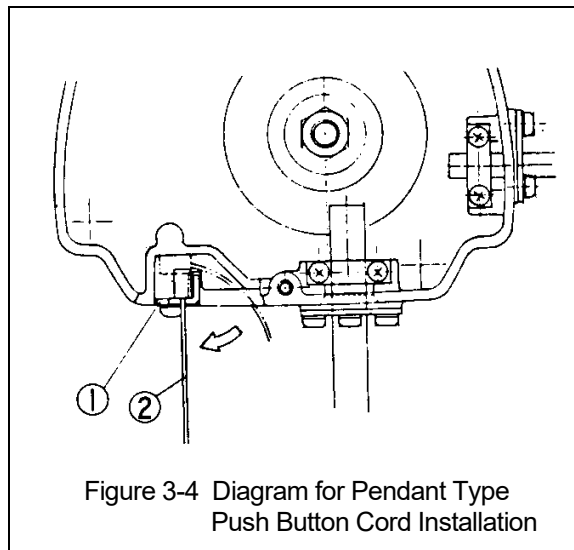

Power Supply Cable – Hoist Connection

A 14-gauge Power Supply Cable is supplied with hoist.

⚠ CAUTION When the power source is far away and an extension supply cable is required, an adequate gauge size.

Power Supply Cable - Installation

If the hoist is hook mounted to a fixed support ensure that the Power Supply Cable is properly installed and supported between the hoist and the electrical power supply.

If the hoist is installed on a manual trolley, then the Power Supply Cable must be installed along the beam that the trolley runs on. For curved beams a special cable suspension system will be needed, and this instruction does not apply. For straight beams install the Power Supply Cable as follows:

- Install a Guide Wire System parallel to the beam.
- For a manual trolley the Guide Wire should be positioned slightly outside the hoist's Cable Support.

3.7.4 Connection to Electrical Power Source - The white and black wires of the Power Supply Cable should be connected to an Electric Power Disconnect Switch or Circuit Breaker.

3.7.5 Fuse/Breaker Capacity - The hoist's power supply should be equipped with overcurrent protection such as fuses, which should be selected for 110% to 120% of total listed full load amperage, and should be dual element time-delay fuses. Refer to the motor nameplate for the full load amperage draw.

3.7.6 **⚠ DANGER** Grounding - An improper or insufficient ground connection creates an electrical shock hazard when touching any part of the hoist or trolley. In the Power Supply Cable the ground wire will be either Green with Yellow stripe or solid Green. It should always be connected to a suitable ground connection. Do not paint the trolley wheel running surfaces of the beam as this can affect grounding.

3.8 Mini Trolley Installation

3.8.1 Mini Trolley - Follow instructions below to install the trolley. Refer to Figure 3-6.

- 1) Remove the Top Hook Assembly from the hoist.
- 2) Refer to Table 3-3 for placement of Adjusting Spacers for the flange width "B" of the traversing beam. The position of Adjusting Spacers differs with flange width. If the beam flange width is not listed in Table 3-3, use the next size smaller and make adjustments in accordance with step 3. Use all 32 Adjusting Spacers provided.

Table 3.3 Quantity and Position of Trolley Spacers					
Flange Width (in)	Number of spacers				
	Outside Left Frame	Inside Left Frame	Inside Yoke	Inside Right Frame	Outside Right Frame
2	8	6	4	6	8
2 5/16	6	7	4	8	7
2 1/2	6	8	4	8	6
2 11/16	5	8	4	9	6
2 13/16	5	9	4	9	5
3	4	10	4	10	4
3 1/4	3	11	4	11	3
3 5/16	3	11	4	11	3
3 9/16	2	12	4	12	2
3 11/16	1	12	4	13	2
3 7/8	0	13	4	14	1
3 15/16	0	14	4	14	0

- 3) Refer to Figure 3-6 and assemble the Trolley Frames, Adjusting Spacers and Socket Bolts onto the Top Yoke. Install and hand tighten the Hex Nuts on the Socket Bolts. Verify that dimension "A" is approximately 0.12 - 0.16 in (3-4mm) greater than "B" (flange width). If "A" does not fall within the specified range, move Adjusting Spacers from the inside of the Trolley Frame to the outside or from the

outside to the inside as necessary to obtain the proper "A" dimension, irrespective of the numbers in Table 3-3.

- 4) Install the trolley and hoist onto traversing beam using one of the following 2 methods:
 - Preferred Method – Sliding adjusted the trolley connected with hoist onto the traversing beam from the beam end is the most convenient and recommended method. If the trolley can be mounted from the end of the beam then: Remove the trolley end-stop from the beam and set the trolley on the beam from the end. Securely re-install the trolley end stop on the beam.
 - Optional Method – If the trolley cannot be mounted from the end of the beam, loosen the Hex Nuts and spread the trolley Frames. Lift the trolley and hoist onto the beam from below. Push the trolley frames together, adjust the spacing as in accordance with Step 3 and hand tighten the hex Nuts.
- 5) Check for contact between all four Trolley Wheels and the rail surface. Shift the Trolley Frame until all Trolley Wheels rest on the rail surface. Tighten the Hex Nuts and install the two (2) U-Nuts onto the Socket Bolts tighten against the Hex Nuts. Install the Split Pins onto the Socket Bolts and bend securely.
- 6) **⚠ WARNING** Incorrect number of Adjusting Spacers may cause the trolley to not move or to drop. To avoid these hazards, always make sure to use all 32 spacers and confirm that $A - B = 0.12 - 0.16$ in (3-4mm).
- 7) **⚠ WARNING** To prevent the trolley from dropping, firmly fasten the Socket Bolt, Nut and U-Nut. Insert Split Pin and bend the ends 90 degrees or more.

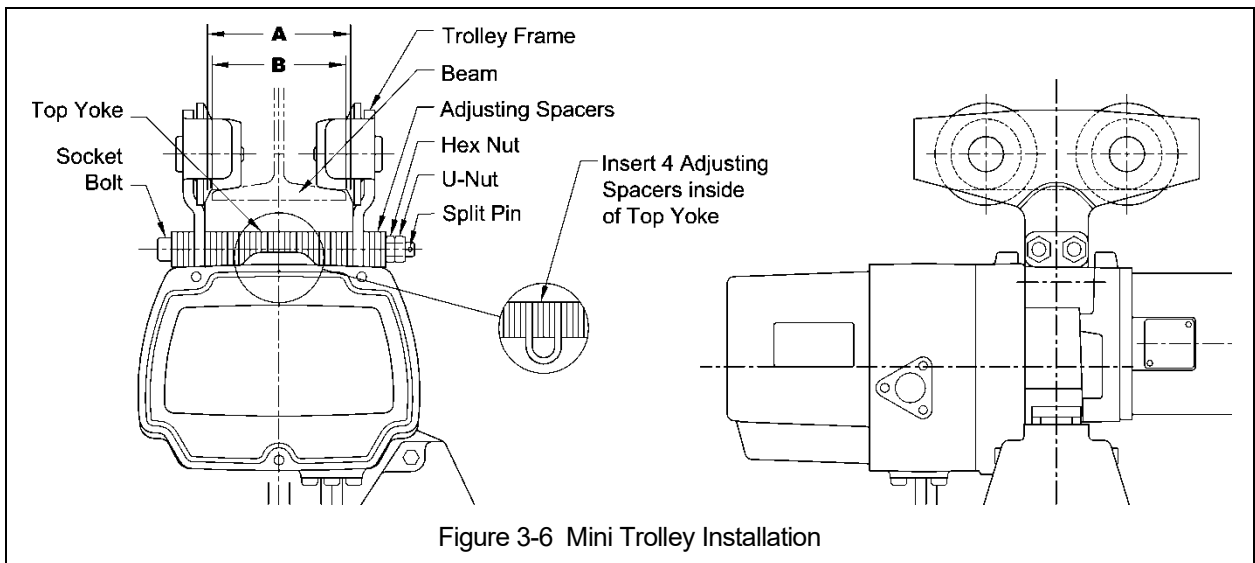

- 3.8.2 **⚠ WARNING** For all trolley suspended electric chain hoists, rail stops must be installed at each end of the rail. Failure to install rail stops will allow the hoist and trolley to fall off the end of the rail and thus cause an accident that could result in injury and/ or property damage. The stops must be positioned so as to not exert impact force on the electric chain hoist frame or trolley wheels. They must contact the ends of the trolley side frames.

3.9 Pre-operational Checks and Trial Operation

- 3.9.1 **⚠ WARNING** Confirm the adequacy of the rated capacity for all slings, chains, wire ropes and all other lifting attachments before use. Inspect all load suspension members for damage prior to use and replace or repair all damaged parts.
- 3.9.2 **⚠ WARNING** Verify and correct all chain irregularities prior to operating the hoist. For reference see Section 3.2.
- 3.9.3 Measure and record the “k” dimension of all hooks on hoist. See Table 5-5 under Section 5, “Inspection”.
- 3.9.4 Record the hoist’s Code, Lot and Serial Number (from the name plate on the hoist; see Section 9) in the space provided on the cover of this manual.
- 3.9.5 Ensure that the hoist is properly installed to either a fixed point, or trolley, whichever applies
- 3.9.6 If hoist is installed on a trolley, ensure that
- trolley is properly installed on the beam, and
 - stops for the trolley are correctly positioned and securely installed on the beam.
- 3.9.7 Ensure that all nuts, bolts and split pins (cotter pins) are sufficiently fastened.
- 3.9.8 Pull down on the Pendant and ensure that the Cord Strain Relief Cable takes the force, not the Pendant Cord.
- 3.9.9 **⚠ CAUTION** Check supply voltage before everyday use. If the voltage varies more than 10% of the rated value, electrical devices may not function normally.
- 3.9.10 Confirm proper operation.
- Before operating read and become familiar with Section 4 - Operation.
 - Before operating ensure that the hoist (and trolley) meets the Inspection, Testing and Maintenance requirements of ANSI/ASME B30.16.
 - Before operating ensure that nothing will interfere with the full range of the hoist’s (and trolley’s) operation.

4.0 Operation

4.1 Introduction

⚠ DANGER
DO NOT WALK UNDER A SUSPENDED LOAD

⚠ WARNING

HOIST OPERATORS SHALL BE REQUIRED TO READ THE OPERATION SECTION OF THIS MANUAL, THE WARNINGS CONTAINED IN THIS MANUAL, INSTRUCTION AND WARNING LABELS ON THE HOIST OR LIFTING SYSTEM, AND THE OPERATION SECTIONS OF ANSI/ASME B30.16 and ANSI/ASME B30.10. THE OPERATOR SHALL ALSO BE REQUIRED TO BE FAMILIAR WITH THE HOIST AND HOIST CONTROLS BEFORE BEING AUTHORIZED TO OPERATE THE HOIST OR LIFTING SYSTEM.

HOIST OPERATORS SHOULD BE TRAINED IN PROPER RIGGING PROCEDURES FOR THE ATTACHMENT OF LOADS TO THE HOIST HOOK.

HOIST OPERATORS SHOULD BE TRAINED TO BE AWARE OF POTENTIAL MALFUNCTIONS OF THE EQUIPMENT THAT REQUIRE ADJUSTMENT OR REPAIR, AND TO BE INSTRUCTED TO STOP OPERATION IF SUCH MALFUNCTIONS OCCUR, AND TO IMMEDIATELY ADVISE THEIR SUPERVISOR SO CORRECTIVE ACTION CAN BE TAKEN.

HOIST OPERATORS SHOULD HAVE NORMAL DEPTH PERCEPTION, FIELD OF VISION, REACTION TIME, MANUAL DEXTERITY, AND COORDINATION.

HOIST OPERATORS SHOULD **NOT** HAVE A HISTORY OF OR BE PRONE TO SEIZURES, LOSS OF PHYSICAL CONTROL, PHYSICAL DEFECTS, OR EMOTIONAL INSTABILITY THAT COULD RESULT IN ACTIONS OF THE OPERATOR BEING A HAZARD TO THE OPERATOR OR TO OTHERS.

HOIST OPERATORS SHOULD **NOT** OPERATE A HOIST OR LIFTING SYSTEM WHEN UNDER THE INFLUENCE OF ALCOHOL, DRUGS, OR MEDICATION.

OVERHEAD HOISTS ARE INTENDED ONLY FOR VERTICAL LIFTING SERVICE OF FREELY SUSPENDED UNGUIDED LOADS. DO **NOT** USE HOIST FOR LOADS THAT ARE NOT LIFTED VERTICALLY, LOADS THAT ARE NOT FREELY SUSPENDED, OR LOADS THAT ARE GUIDED.

NOTICE

- Read ANSI/ASME B30.16 and ANSI/ASME B30.10.
- Read the hoist manufacturer's Operating and Maintenance Instructions.
- Read all labels attached to equipment.

The operation of an overhead hoist involves more than activating the hoist's controls. Per the ANSI/ASME B30 standards, the use of an overhead hoist is subject to certain hazards that cannot be mitigated by engineered features, but only by the exercise of intelligence, care, common sense, and experience in anticipating the effects and results of activating the hoist's controls. Use this guidance in conjunction with other warnings, cautions, and notices in this manual to govern the operation and use of your overhead hoist.

4.2 Shall's and Shall Not's for Operation

WARNING

Improper operation of a hoist can create a potentially hazardous situation which, if not avoided, could result in death or serious injury, and substantial property damage. To avoid such a potentially hazardous situation **THE OPERATOR SHALL:**

- **NOT** lift more than rated load for the hoist.
- **NOT** operate unless load is centered under hoist.
- **NOT** use damaged hoist or hoist that is not working properly.
- **NOT** use hoist with twisted, kinked, damaged, or worn chain.
- **NOT** use the hoist to lift, support, or transport people.
- **NOT** lift loads over people.
- **NOT** apply load unless load chain is properly seated in the load sheave (and idle sheave for hoist with two chain falls).
- **NOT** use the hoist in such a way that could result in shock or impact loads being applied to the hoist.
- **NOT** attempt to lengthen the load chain or repair damaged load chain.
- **NOT** operate hoist when it is restricted from forming a straight line from hook to hook in the direction of loading.
- **NOT** use load chain as a sling or wrap load chain around load.
- **NOT** apply the load to the tip of the hook or to the hook latch.
- **NOT** apply load if binding prevents equal loading on all load-supporting chains.
- **NOT** operate beyond the limits of the load chain travel.
- **NOT** operate hoist with missing/damaged cushion rubbers, stoppers or washers.
- **NOT** leave load supported by the hoist unattended unless specific precautions have been taken.
- **NOT** allow the chain, or hook to be used as an electrical or welding ground.
- **NOT** allow the chain, or hook to be touched by a live welding electrode.
- **NOT** remove or obscure the warnings on the hoist.
- **NOT** operate a hoist on which the safety placards or decals are missing or illegible.
- Be familiar with operating controls, procedures, and warnings.
- Make sure the unit is securely attached to a suitable support before applying load.
- Make sure load slings or other approved single attachments are properly sized, rigged, and seated in the hook saddle.
- Take up slack carefully - make sure load is balanced and load-holding action is secure before continuing.
- Make sure all persons stay clear of the supported load.
- Protect the hoist's load chain from weld splatter or other damaging contaminants.
- Report Malfunctions or unusual performances (including unusual noises) of the hoist and remove the hoist from service until the malfunction or unusual performance is resolved.
- Make sure hoist limit switches function properly.
- Warn personnel before lifting or moving a load.
- Warn personnel of an approaching load.

CAUTION

Improper operation of a hoist can create a potentially hazardous situation which, if not avoided, could result in minor or moderate injury, or property damage. To avoid such a potentially hazardous situation **THE OPERATOR SHALL:**

- Maintain a firm footing or be otherwise secured when operating the hoist.
- Check brake function by tensioning the hoist prior to each lift operation.
- Use hook latches. Latches are to retain slings, chains, etc. under slack conditions only.
- Make sure the hook latches are closed and not supporting any parts of the load.
- Make sure the load is free to move and will clear all obstructions.
- Avoid swinging the load or hook.
- Make sure hook travel is in the same direction as shown on controls.
- Inspect the hoist regularly, replace damaged or worn parts, and keep appropriate records of maintenance.
- Use the hoist manufacturer's recommended parts when repairing the unit.
- Lubricate load chain per hoist manufacturer's recommendations.
- **NOT** use the hoist load limiting or warning device to measure load.
- **NOT** use limit switches as routine operating stops. They are emergency devices only.
- **NOT** allow your attention to be diverted from operating the hoist.
- **NOT** allow the hoist to be subjected to sharp contact with other hoists, structures, or objects through misuse.
- **NOT** adjust or repair the hoist unless qualified to perform such adjustments or repairs.

4.3 Hoist Controls

4.3.1 Pendant Control – When using the pendant control depress the up button to raise the hoist or the down button to lower the hoist as shown in Figure 4-1 below. To stop motion release the buttons.

4.3.2 **⚠ CAUTION** Make sure the motor completely stops before reversing direction.

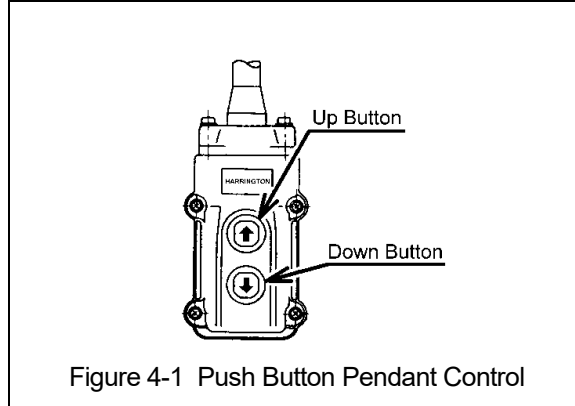

4.4 Electric Chain Hoist with Trolley

4.4.1 To operate the electric chain hoist with trolley, move it horizontally by either pushing the lifted load or the Load Chain.

4.4.2 **⚠ WARNING** Never pull the coiled cord, pendant or pendant cord. Pulling the coiled cord, pendant or the pendant cord may disconnect cord wires. Disconnected wire(s) may cause a short circuit in the hoist body or any surrounding conductor, giving the operator electric shock.

4.4.3 **⚠ WARNING** Always move the hoist horizontally by grasping the cylinder grip or pushing the load.

4.5 Lifting Speed Adjustment Using Potentiometer

- 4.5.1 **⚠️WARNING** Always disconnect power to the hoist before making any lifting speed adjustments. When making multiple lifting speed adjustments, be sure to disconnect power before each adjustment. Failure to do so may result in electrical shock.
- 4.5.2 EDV model hoists are equipped with adjustable speed control using a variable resistor (potentiometer) located under the control cover (as seen in Figure 4-2).
- 4.5.3 Using a small flathead screwdriver, engage the slotted potentiometer dial and rotate the potentiometer dial to make adjustments to the lifting speed. To achieve the slowest lifting speed, rotate the potentiometer dial fully clockwise to its limit. To achieve the fastest lifting speed, rotate the potentiometer dial fully counterclockwise to its limit. Intermediate lifting speeds can be achieved with dial adjustments between the upper and lower limits of the potentiometer.

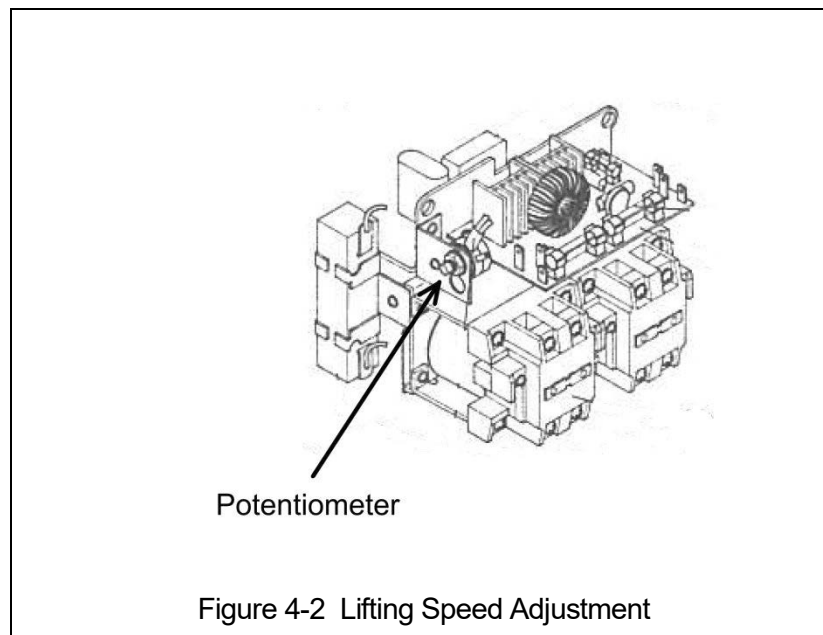

5.0 Inspection

5.1 General

- 5.1.1 The inspection procedure herein is based on ANSI/ASME B30.16. The following definitions are from ANSI/ASME B30.16 and pertain to the inspection procedure below.
- **Designated Person** – a person selected or assigned as being competent to perform the specific duties to which he/she is assigned.
 - **Qualified Person** – a person who, by possession of a recognized degree or certificate of professional standing, or who, by extensive knowledge, training, and experience, has successfully demonstrated the ability to solve or resolve problems relating to the subject matter and work.
 - **Normal Service** – that distributed service which involves operation with randomly distributed loads within the rated load limit, or uniform loads less than 65% of rated load for not more than 25% of the time.
 - **Heavy Service** – that service which involves operation within the rated load limit which exceeds normal service.
 - **Severe Service** – that service which involves normal or heavy service with abnormal operating conditions.

5.2 Inspection Classification

- 5.2.1 Initial Inspection – prior to initial use, all new, altered, or modified hoists shall be inspected by a designated person to ensure compliance with the applicable provisions of this manual.
- 5.2.2 Inspection Classification – the inspection procedure for hoists in regular service is divided into two general classifications based upon the intervals at which inspection should be performed. The intervals in turn are dependent upon the nature of the critical components of the hoist and the degree of their exposure to wear, deterioration, or malfunction. The two general classifications are herein designated as FREQUENT and PERIODIC, with respective intervals between inspections as defined below.
- 5.2.3 FREQUENT Inspection – visual examinations by the operator or other designated personnel with intervals per the following criteria:
- Normal service – monthly
 - Heavy service – weekly to monthly
 - Severe service – daily to weekly
 - Special or infrequent service – as recommended by a qualified person before and after each occurrence.
- 5.2.4 PERIODIC Inspection – visual inspection by a designated person with intervals per the following criteria:
- Normal service – yearly
 - Heavy service – semiannually
 - Severe service – quarterly
 - Special or infrequent service – as recommended by a qualified person before the first such occurrence and as directed by the qualified person for any subsequent occurrences.

5.3 Frequent Inspection

- 5.3.1 Inspections should be made on a FREQUENT basis in accordance with Table 5-1, "Frequent Inspection." Included in these FREQUENT Inspections are observations made during operation for any defects or damage that might appear between Periodic Inspections. Evaluation and resolution of the results of FREQUENT Inspections shall be made by a designated person such that the hoist is maintained in safe working condition.

Table 5-1 Frequent Inspection
All functional operating mechanisms for maladjustment and unusual sounds.
Operation of limit switch and associated components
Hoist braking system for proper operation
Hooks in accordance with ANSI/ASME B30.10
Hook latch operation
Load chain in accordance with Section 5.7
Load chain reeving for compliance with Section 3.2

5.4 Periodic Inspection

- 5.4.1 Inspections should be made on a PERIODIC basis in accordance with Table 5-2, "Periodic Inspection." Evaluation and resolution of the results of PERIODIC Inspections shall be made by a designated person such that the hoist is maintained in safe working condition.
- 5.4.2 For inspections where load suspension parts of the hoist are disassembled, a load test per ANSI/ASME B30.16 must be performed on the hoist after it is re-assembled and prior to its return to service.

Table 5-2 Periodic Inspection
Requirements of frequent inspection.
Evidence of loose bolts, nuts, or rivets.
Evidence of worn, corroded, cracked, or distorted parts such as load blocks, suspension housing, chain attachments, clevises, yokes, suspension bolts, shafts, gears, bearings, pins and rollers.
Evidence of damage to hook retaining nuts or collars and pins, and welds or rivets used to secure the retaining members.
Evidence of damage or excessive wear of load and idler sheaves.
Evidence of excessive wear on motor or load brake.
Electrical apparatus for signs of pitting or any deterioration of visible controller contacts.
Evidence of damage of supporting structure or trolley, if used.
Function labels on pendant control stations for legibility.
Warning label properly attached to the hoist and legible (see Section 1.2).
End connections of load chain.

5.5 Occasionally Used Hoists

5.5.1 Hoists that are used infrequently shall be inspected as follows prior to placing in service:

- Hoist Idle More Than 1 Month, Less Than 1 Year: Inspect per FREQUENT Inspection criteria in Section 5.3.
- Hoist Idle More Than 1 Year: Inspect per PERIODIC Inspection criteria in Section 5.4.

5.6 Inspection Records

5.6.1 Dated inspection reports and records should be maintained at time intervals corresponding to those that apply for the hoist's PERIODIC interval per Section 5.2.4. These records should be stored where they are available to personnel involved with the inspection, maintenance, or operation of the hoist.

5.6.2 A long range chain inspection program should be established and should include records of examination of chains removed from service so a relationship can be established between visual observation and actual condition of the chain.

5.7 Inspection Methods and Criteria

5.7.1 This section covers the inspection of specific items. The list of items in this section is based on those listed in ANSI/ASME B30.16 for the Frequent and Periodic Inspection. In accordance with ANSI/ASME B30.16, these inspections are not intended to involve disassembly of the hoist. Rather, disassembly for further inspection would be required if frequent or periodic inspection results so indicate. Such disassembly and further inspection should only be performed by a qualified person trained in the disassembly and re-assembly of the hoist.

Table 5-3 Hoist Inspection Methods and Criteria

Item	Method	Criteria	Action
Functional operating mechanisms.	Visual, Auditory	Mechanisms should be properly adjusted and should not produce unusual sounds when operated.	Repair or replace as required.
Limit Switch (model ED3)	Function	Proper operation. Actuation of limit switch should stop hoist.	Repair or replace as required.
Braking System Operation	Function	Braking distance with rated capacity should not exceed approximately five chain links.	Repair or replace as required.
Hooks - Surface Condition	Visual	Should be free of significant rust, weld splatter, deep nicks, or gouges.	Replace.
Hooks - Fretting wear	Measure	The "u" and "t" dimensions should not be less than discard value listed in Table 5-5	Replace.
Hooks - Stretch	Measure	The "k" dimension should not exceed the measured value for discard from Table 5-5 (See Section 3.9).	Replace.
Hooks - Bent Shank or Neck	Visual	Shank and neck portions of hook should be free of deformations.	Replace.
Hooks - Yoke Assembly	Visual	Should be free of significant rust, weld splatter, nicks, gouges. Holes should not be elongated, fasteners should not be loose, and there should be no gap between mating parts.	Tighten or replace as required.

Table 5-3 Hoist Inspection Methods and Criteria

Item	Method	Criteria	Action
Hooks - Swivel Bearing	Visual, Function	Bearing parts and surfaces should not show significant wear, and should be free of dirt, grime and deformations. Hook should rotate freely with no roughness.	Clean/lubricate, or replace as required.
Hooks - Hook Latches	Visual, Function	Latch should not be deformed. Attachment of latch to hook should not be loose. Latch spring should not be missing and should not be weak. Latch movement should not be stiff - when depressed and released latch should snap smartly to its closed position.	Replace.
Cylinder Hook Chuck - Ball Guide (DA Model)	Visual, Function	Ball Guide should not be worn or deformed. Ball Guide should interact properly with the Spring Collar to retain the hook shank.	Replace.
Load Chain - Surface Condition	Visual	Should be free of rust, nicks, gouges, dents and weld splatter. Links should not be deformed, and should not show signs of abrasion. Surfaces where links bear on one another should be free of significant wear.	Replace.
Load Chain - Pitch and Wire Diameter	Measure	The "P" dimension should not be greater than maximum value listed in Table 5-6 . The "d" dimension should not be less than minimum value listed in Table 5-6 .	Replace. Inspect Load Sheave by qualified person.
Load Chain - Lubrication	Visual, Auditory	Entire surface of each chain link should be coated with lubricant and should be free of dirt and grime. Chain should not emit cracking noise when hoisting a load.	Clean/lubricate (see Section 6.1).
Load Chain - Reeving	Visual	Chain should be reeved properly through Load Sheave - refer to Section 6.2 . Chain, Cushion Rubbers, Washers and Stoppers should be installed properly	Reeve/Install chain properly.
Chain Container (optional)	Visual	Container should not be damaged. Brackets should not be deformed or missing.	Replace
Housing and Mechanical Components	Visual, Auditory, Vibration, Function	Hoist components including load blocks, suspension housing, chain attachments, clevises, yokes, suspension bolts, shafts, gears, bearings, pins and rollers should be free of cracks, distortion, significant wear and corrosion. Evidence of same can be detected visually or via detection of unusual sounds or vibration during operation.	Replace.
Bolts, Nuts and Rivets	Visual, Check with Proper Tool	Bolts, nuts and rivets should not be loose.	Tighten or replace as required.
Motor Brushes	Measure, Visual	The "F" dimension should not be less than minimum value listed in Table 5-4 .	Replace.
Contactors Contacts	Visual	Contacts should be free of significant pitting or deterioration	Replace.

Table 5-3 Hoist Inspection Methods and Criteria

Item	Method	Criteria	Action
Cushion Rubber	Visual	Should be free of significant deformation.	Replace.
Pendant - Switches	Function	Depressing and releasing push buttons should make and break contacts in switch contact block and result in corresponding electrical continuity or open circuit. Push buttons should be interlocked either mechanically or electrically to prevent simultaneous energization of circuits for opposing motions (e.g. up and down).	Repair or replace as necessary.
Pendant - Housing	Visual	Pendant housing should be free of cracks and mating surfaces of parts should seal without gaps.	Replace.
Pendant - Wiring	Visual	Wire connections to switches in pendant should not be loose or damaged.	Tighten or repair
Pendant - Cord	Visual, Electrical Continuity	Surface of cord should be free from nicks, gouges, and abrasions. Each conductor in cord should have 100% electrical continuity even when cord is flexed back-and-forth. Pendant Cord Strain Relief Cable should absorb the entire load associated with forces applied to the pendant.	Replace.
Pendant - Labels	Visual	Labels denoting functions should be legible.	Replace.
Warning Labels	Visual	Warning Labels should be affixed to the hoist (see Section 1.2) and they should be legible.	Replace.
Hoist Capacity Label	Visual	The label that indicates the capacity of the hoist should be legible and securely attached to the hoist.	Replace.

Table 5-4 Motor Brush Dimensions

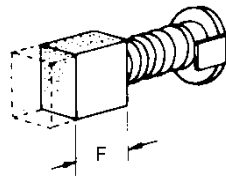

Capacity (lbs)	"F" Dimension inch (mm)
	Discard
250 to 1000	0.31(8.0)

Table 5-5 Top Hook & Bottom Hook Dimensions

"k" Measured When New:

Top: _____

Bottom: _____

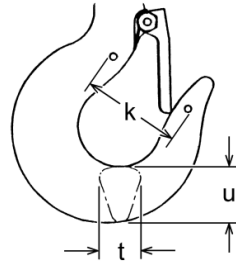

Capacity (lbs)	Hook	*Nominal "k" Dimension inch (mm)	"u" Dimension inch (mm)		"t" Dimension inch (mm)	
			Standard	Discard	Standard	Discard
250 to 500	Bottom	1.73(44)	0.67(17)	0.60(15.3)	0.48(12.1)	0.43(10.9)
	Top	1.77(45)	0.67(17)	0.60(15.3)	0.28(7.0)	0.25(6.3)
1000	Bottom	1.65(42)	0.93(23.5)	0.88(22.3)	0.69(17.5)	0.65(16.6)
	Top	1.77(45)	0.67(17)	0.60(15.3)	0.28(7.0)	0.25(6.3)

* These values are nominal since the dimension is not controlled to a tolerance. The **"k" dimension** should be measured when the hook is new - this becomes a reference measurement. Subsequent measurements are compared to this reference to make determinations about hook deformation/stretch. See Section 5.7, "Hooks - Stretch".

Table 5-6 Chain Wear Dimensions

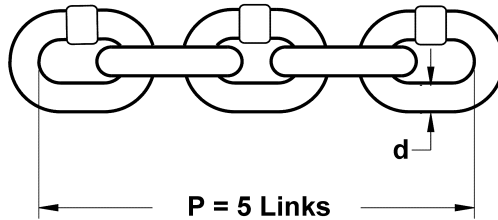

Capacity (lbs)	"P" Dimension inch (mm)		"d" Dimension Wear Limit Inch (mm)	
	Standard	Discard	Standard	Discard
250 to 1000	2.38 (60.5)	2.43 (61.7)	0.16 (4.0)	0.13 (3.3)

Item	Method	Criteria	Action
Functional operating mechanisms.	Visual, Auditory	Mechanisms should be properly adjusted and should not produce unusual sounds when operated.	Repair or replace as required.
Mechanical Components	Visual, Auditory, Vibration, Function	Trolley components including, suspension shafts, track wheels, track wheel axles, suspension bolts, shafts, bearings and pins should be free of cracks, distortion, significant wear and corrosion. Evidence of same can be detected visually or via detection of unusual sounds or vibration during operation.	Replace.
Side Plates	Visual	Must be free of significant deformation	Replace.
Bolts, Nuts, Snap Rings, and Split Pins	Visual, Check with Proper Tool	Bolts, nuts, snap rings and split pins should not be loose.	Tighten or replace as required.
Track Wheel – Tread and Flange	Visual, Measure	Diameter of the tread surface and the thickness of the wheel flange should not be less than the discard value shown in Table 5-8 .	Replace.
Suspension Bolts	Visual, Measure	Suspension bolts should not be bent. Diameter should not be worn by 10% or more.	Replace.
Warning Labels	Visual	Warning Labels should be affixed to the pendant cord (see Section 1.2) and they should be legible.	Replace.
Trolley Capacity Label	Visual	The label that indicates the capacity of the trolley should be legible and securely attached to the trolley.	Replace.

“D” Dimension inch (mm)		“t” Dimension inch (mm)	
Standard	Discard	Standard	Discard
1.57 (40)	1.50 (38)	0.32 (8)	0.21 (5.33)

6.0 Maintenance and Handling

6.1 Lubrication

6.1.1 Load Chain

- For longer life, the load chain should be lubricated.
- The load chain lubrication should be accomplished after cleaning the load chain with an acid free cleaning solution.
- Apply Harrington lubricating grease (Part No. ER1BS1951) or an equivalent to industrial general lithium grease, NLGI No. 0, to the bearing surfaces of the load chain links as indicated by the shaded areas in Figure 6-1. Also apply the grease to the areas of the load chain (shaded areas in Figure 6-1) that contact the load sheave. Insure that the grease is applied to the contact areas in the load sheave pockets.
- Machine or gear oil (grade ISO VG 46 or 68 oil or equivalent) may be used as an alternative lubricant but must be applied more frequently.

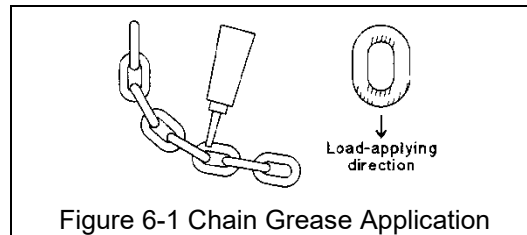

- The chain should be lubricated every 3 months (more frequently for heavier usage or severe conditions).
- For dusty environments, it is acceptable to substitute a dry lubricant.

6.1.2 Hooks and Suspension Components:

- Hooks - Bearings should be cleaned and lubricated at least once per year for normal usage. Clean and lubricate more frequently for heavier usage or severe conditions.
- Suspension Pins - Lubricate at least twice per year for normal usage; more frequently for heavier usage or severe conditions.

6.1.3 Gear Box:

- **⚠ WARNING** Not using Harrington ED oil or the wrong quantity of oil may prevent the friction clutch from working properly and may affect the ability of the hoist to hold the load. Refer to Section 3.1 for the correct quantity.
- Change gear oil at least once every 5 years. The oil should be changed more frequently depending on the hoist's usage and operating environment.
- To change the gear oil, remove both fill and drain plugs and allow the old oil drain completely. Replace the drain plug and refill the gear case with the correct quantity of new oil or until the oil level is even with the bottom of the oil check hole. Refer to Figure 3-1.
- **NOTICE** Dispose of the used oil in accordance with local regulations.

6.2 Load Chain

6.2.1 Lubrication and Cleaning – refer to Section 6.1.

6.2.2 Load Chain Replacement:

- 1) **⚠ CAUTION** The hoist must be properly powered and operational in order to perform the following procedures.
- 2) **⚠ WARNING** Be certain that the replacement Load Chain is obtained from Harrington and is the exact size, grade and construction as the original chain. The new Load Chain must have an odd number of links so that both its end links have the same orientation. If the Load Chain is being replaced due to damage or wear out, destroy the old chain to prevent its reuse.
- 3) **⚠ CAUTION** When replacing load chain, check for wear on mating parts, i.e. Load Sheave, Chain Guides and Idle Sheaves, and replace parts if necessary.
- 4) Remove all chain components including the Bottom Hook Set Assembly, Stoppers, Cushion Rubbers, Washers and Chain Pin from the chain for reuse on new chain. Inspect and replace any damaged or worn parts.
- 5) Using a C-link, attach the new chain to the end link of the old chain on the no-load side. The end link of the new Load Chain should be connected so that the welded portions of the Load Chain's standing links are oriented to the outside as they pass over the sheave. Refer to Figure 6-1.
- 6) Operate the hoist down to move the chain through the hoist body. Stop when a sufficient amount of new chain is accumulated on the load side.
- 7) Attach the chain components (step 4 above) to the chain. Refer to Section 3.2 for the proper locations.
- 8) **⚠ WARNING** Make sure Stoppers, Cushion Rubbers, Washers and Split Pins are properly installed.
- 9) After installation has been completed, perform steps outlined in Section 3.8 "Pre-operational Checks and Trial Operation".

6.3 Mechanical Load Brake with Friction Clutch

6.3.1 Mechanical Load Brake with Friction Clutch – If abnormal operation or slippage occurs do NOT attempt to disassemble or adjust the Mechanical Load Brake with Friction Clutch. Replace the worn or malfunctioning Mechanical Load Brake with Friction Clutch as an assembly with a new, factory adjusted part.

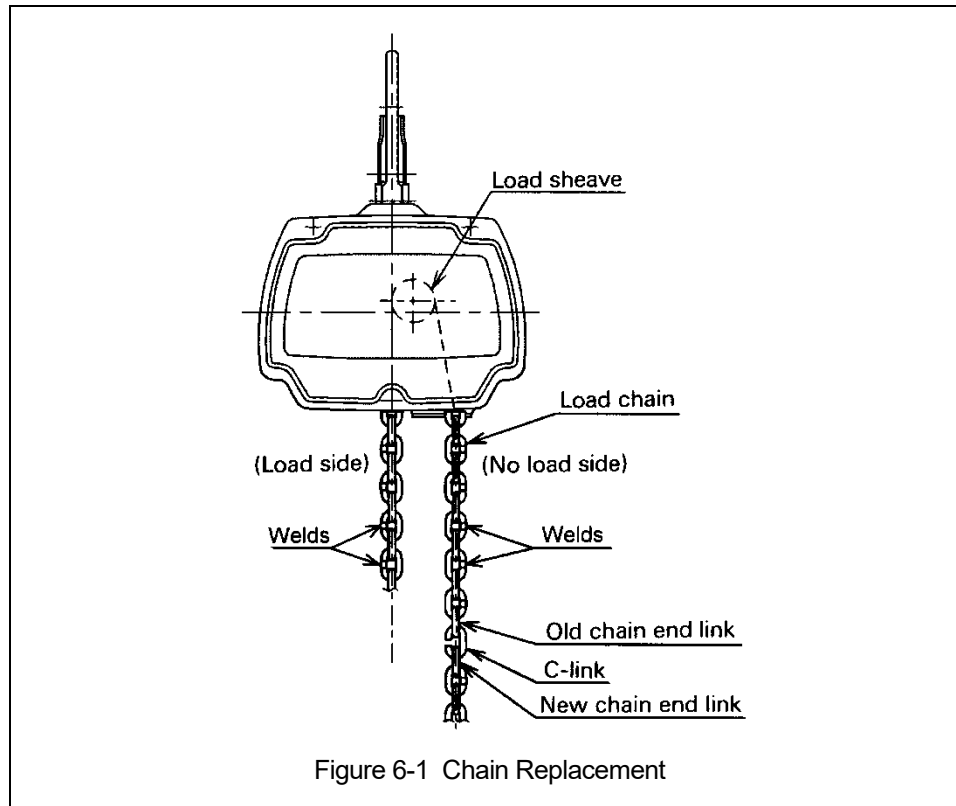

6.4 Fuses

6.4.1 Spare fuses are attached inside the controller cover (the capacity/nameplate side). The fuse sizes are shown in the Table 6-1.

Capacity (lbs)	Main Fuse Rating (Amps)
250	10
350	15
525	
1000	

6.4.2 In addition, current model DS and DA units have a second smaller fuse (5 x 20mm) rated at 0.1 AMPS.

6.5 Storage

6.5.1 The storage location should be clean and dry.

6.6 Outdoor Installation

6.6.1 For hoist installations that are outdoors, the hoist should be covered when not in use.

6.6.2 Possibility of corrosion on components of the hoist increases for installations where salt air and high humidity are present. Make frequent and regular inspections of the unit's condition and operation.

7.0 Troubleshooting

WARNING

HAZARDOUS VOLTAGES ARE PRESENT IN THE HOIST AND IN CONNECTIONS BETWEEN COMPONENTS.

Before performing ANY troubleshooting on the equipment, de-energize the supply of electricity to the equipment, and lock and tag the supply device in the de-energized position. Refer to ANSI Z244.1, "Personnel Protection - Lockout/Tagout of Energy Sources."

Only Trained and competent personnel should inspect and repair this equipment.

Table 7-1 Troubleshooting Guide

Symptom	Cause	Remedy
Hoist will not operate	Loss of power	Check circuit breakers, switches, fuses and connections on power lines/cable.
	Wrong voltage or frequency	Check voltage and frequency of power supply against the rating on the nameplate of the motor.
	Hoist overload	Reduce load to within rated capacity of hoist.
	Improper, loose, or broken wire in hoist electrical system	Shut off power supply, check wiring connections on hoist control panel and inside push-button pendant.
	Faulty magnetic contactor	Check coil for open or short circuit. Check all connections in the control circuit. Check for open contacts. Replace as needed.
	Motor burned out	Replace motor frame/stator, shaft/rotor, and any other damaged parts.
	Fuses burned out	Replace fuses.
	Brush wear	Inspect both motor brushes per Table 5-4 and replace if necessary.
Hoist lifts but will not lower	Down circuit open	Check circuit for loose connections. Check down side of limit switch for malfunction.
	Broken conductor in pendant cord	Check the continuity for each conductor in the cable. If one is broken, replace entire cable.
	Faulty magnetic contactors	Check coils for open or short circuit. Check all connections on motor circuit. Check for burned contacts. Replace as needed.
	Faulty switch in pendant	Check electrical continuity. Check electrical connections. Replace or repair as needed.

Table 7-1 Troubleshooting Guide

Symptom	Cause	Remedy
Hoist lowers but will not lift	Hoist overloaded	Reduce load to within rated capacity of hoist.
	Low voltage in hoist's power supply	Determine cause of low voltage and bring to within plus or minus 10% of the voltage specified on the motor nameplate. The voltage should be measure at the hoist contactor.
	Up circuit open	Check circuit for loose connections. Check up side of limit switch for malfunction.
	Broken conductor in pendant cord	Check the continuity of each conductor in the cable. If one is broken, replace entire cable.
	Faulty magnetic contactor	Check coils for open or short circuit. Check all connections on motor circuit. Check for burned contacts. Replace as needed.
	Faulty switch in pendant	Check electrical continuity. Check electrical connections. Replace or repair as needed.
	Faulty friction clutch	Repair by a qualified person trained in the repair of hoists and proper friction clutch adjustment procedures. Replace as needed.
Hoist will not lift rated load or does not have the proper lifting speed	Hoist overloaded	Reduce load to within rated capacity.
	Low voltage in hoist's power supply	Determine cause of low voltage and bring to within plus or minus 10% of voltage specified on the motor nameplate. The voltage should be measured at the hoist contactor.
	Faulty friction clutch	If abnormal operation or slippage occurs do NOT attempt to disassemble or adjust the Mechanical Load Brake with Friction Clutch. Replace the worn or malfunctioning Mechanical Load Brake with Friction Clutch as an assembly with a new, factory adjusted part.
Load drifts excessively when hoist is stopped	Mechanical Load brake not holding	Replace as needed.
	Improper gear oil	Replace oil with the correct Harrington ED gear oil.
	Motor demagnetized	Motor demagnetizing is generally caused from using the hoist beyond it's duty rating. Replace stator assembly and reduce usage to comply with the duty rating stated in Table 2-1.
	Dynamic brake resistor burned out	Check resistance and replace if necessary.

Table 7-1 Troubleshooting Guide

Symptom	Cause	Remedy
Hoist operates intermittently	Collectors making poor contact	Check movement of spring loaded arm, weak spring, connections, and shoe. Replace as needed.
	Contactors contacts arcing	Check for burned contacts. Replace as needed.
	Loose connection in circuit	Check all wires and terminals for bad connections. Replace as needed.
	Broken conductor in Pendant Cord	Check for intermittent continuity in each conductor the Pendant Cord. Replace entire Pendant Cord if continuity is not constant.
DA Model - Hook drops out of cylinder chuck	Worn or deformed Ball Guide Tube	Check Ball Guide Tube for excessive wear or deformation. Replace as needed.
Actuation of Limit Switch does not stop hoist	Limit switch defective	Repair or replace as required.
	Bent or worn lever; Lever should move freely.	Repair or replace as required.

8.0 Warranty

All products sold by Harrington Hoists, Inc. are warranted to be free from defects in material and workmanship from date of shipment by Harrington for the following periods:

1 year – Electric and Air Powered Hoists (excluding (N)ER2 Enhanced Features Models and EQ/SEQ Models), Powered Trolleys, Powered Tiger Track Jibs and Gantries, Crane Components, Below the Hook Devices, Spare / Replacement Parts

2 years – Manual Hoists & Trolleys, Beam Clamps

3 years – (N)ER2 Enhanced Features Hoists, EQ/SEQ Hoists, and RY Hoists

5 years – Manual Tiger Track Jibs and Gantries, TNER, EQ/SEQ, and RY Hoist Motor Brakes

10 years – (N)ER2 “The Guardian” Smart Brake

The product must be used in accordance with manufacturer’s recommendations and must not have been subject to abuse, lack of maintenance, misuse, negligence, or unauthorized repairs or alterations.

Should any defect in material or workmanship occur during the above time period in any product, as determined by Harrington Hoist’s inspection of the product, Harrington Hoists, Inc. agrees, at its discretion, either to replace (not including installation) or repair the part or product free of charge and deliver said item F.O.B. Harrington Hoists, Inc. place of business to customer.

Customer must obtain a Return Goods Authorization as directed by Harrington or Harrington’s published repair center prior to shipping product for warranty evaluation. An explanation of the complaint must accompany the product. Product must be returned freight prepaid. Upon repair, the product will be covered for the remainder of the original warranty period. Replacement parts installed after the original warranty period will only be eligible for replacement (not including installation) for a period of one year from the installation date. If it is determined there is no defect, or that the defect resulted from causes not within the scope of Harrington’s warranty, the customer will be responsible for the costs of returning the product.

Harrington Hoists, Inc. disclaims any and all other warranties of any kind expressed or implied as to the product’s merchantability or fitness for a particular application. Harrington will not be liable for death, injuries to persons or property or for incidental, contingent, special or consequential damages, loss or expense arising in connection with the use or inability whatever, regardless of whether damage, loss or expense results from any act or failure to act by Harrington, whether negligent or willful, or from any other reason.

9.0 Parts List

When ordering Parts, please provide the Hoist code number, lot number and serial number located on the Hoist nameplate (see fig. below).

Reminder: Per sections 1.1 and 3.9.4 to aid in ordering Parts and Product Support, record the Hoist code number, lot number and serial number in the space provided on the cover of this manual.



The parts list is arranged into the following sections:

Section	Page
9.1 Housing, Motor, and Gearing Parts.....	42
9.2 ED1000V Additional Parts.....	46
9.3 Power Supply and Pendant Parts	48
9.4 Electric Parts	50
9.5 Mini Trolley Parts.....	52

This Page Intentionally Left Blank

9.1 Housing, Motor, and Gearing Parts

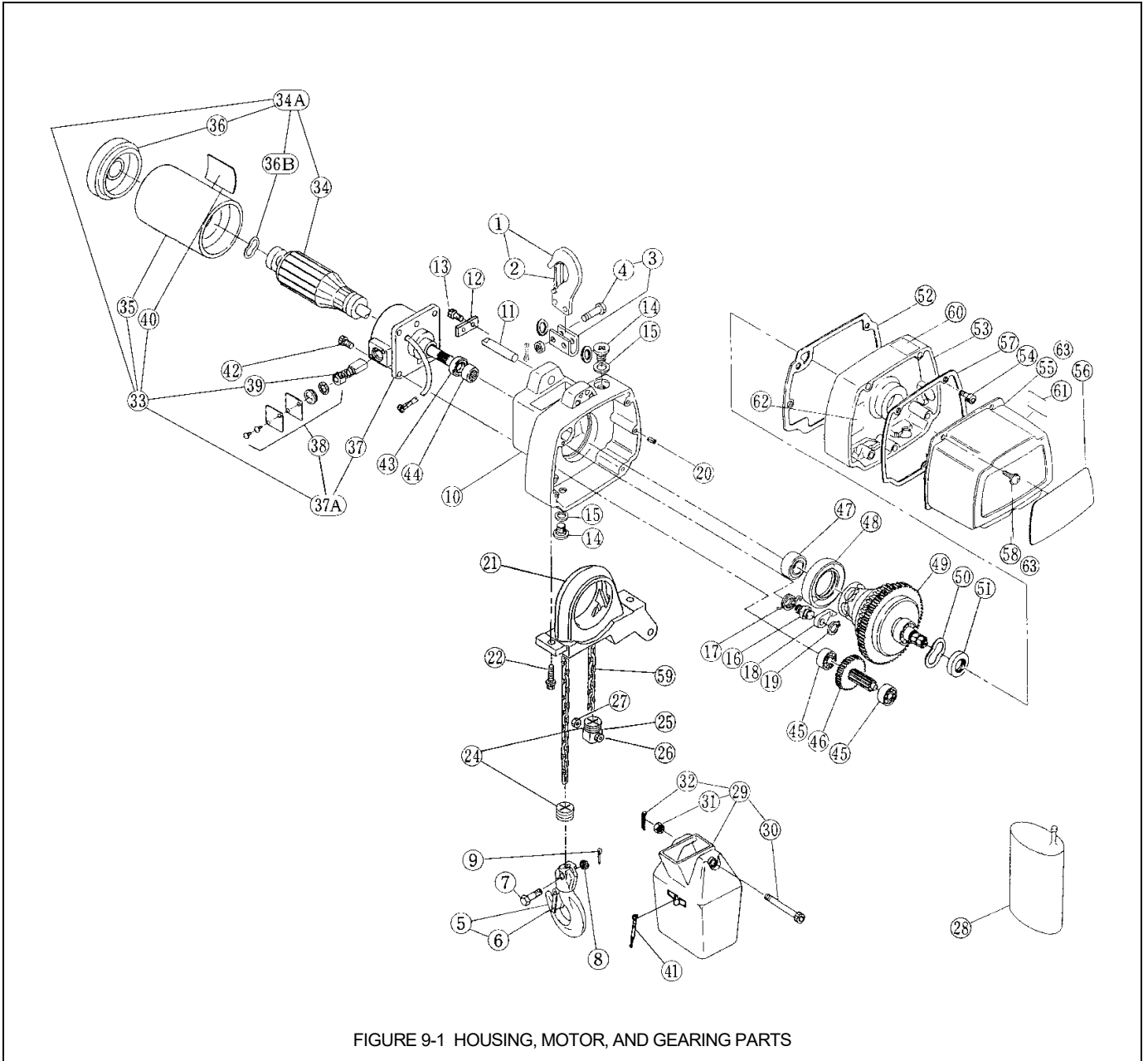

FIGURE 9-1 HOUSING, MOTOR, AND GEARING PARTS

9.1 Housing, Motor, and Gearing Parts

Fig. No.	Part Name	Parts Per Hoist	Capacity (lbs.)			
			250	350	500	1000
1	Top Hook Assembly	1	E2D1001125			
2	Hook Latch Assembly	1	L41071008			
3	Top Yoke Complete Set	1	E2D1011125			
4	Top Pin Assembly	2	M3041010			
5	Bottom Hook Comp. Set	1	E2D1021125			
6	Latch Assembly. B	1	CF071005			
7	Chain Pin	1	E2D041125			
8	Slotted Nut	1	E2D049125			
9	Split Pin	1	9009402			
10	Body	1	E3DBX10S9101	E3DBX24S9101		
11	Top Pin E	1	E2D117125	E2D117350		
12	Shaft Stopper	1		E2D118350		
13	Socket Bolt w/ Spring Washer	2		E2D072350		
14	Oil Plug	2	E3S111003			
15	Plug Packing	2	E3S112003			
16	Pawl Pin	1	E2D269125			
17	Pawl Spring	1	E2D270125			
18	Pawl	1	L4155015			
19	Snap Ring	1	L4188015			
20	Set Pin	2	CF083020			
21	Chain Guide	1	E3DBX10S9401	E3DBX24S9401		
22	Socket Bolt w/ Spring Washer	2	E2D451125			
24	Cushion Rubber	2	E3DBX10S9046			
25	Stopper	1	E1DBX10S9045			
26	Socket Bolt w/ Spring Washer	1	E2D086125			
27	Lever Nut	1	E2D087125			
28	Gear Oil	1	E2D90B125	E2D90B350		
29	Chain Container 10 ft max lift	1	E2D1831125			
	Chain Container 20 ft max lift (10 ft. for ED1000V)	1	E2D1835125			
30	Socket Bolt BP	1	E2D854125			
31	U Nut	1	E2D853125			
32	Split Pin	1	9009402			

9.1 Housing, Motor, and Gear Parts

Fig. No.	Part Name	Parts Per Hoist	Capacity (lbs.)			
			250	350	500	1000
33	Motor Complete Set for 120V, 50/60 Hz	1	E2D1501P125	E2D1501P350		
35	Stator Assembly	1	7023001	E2D5508P350		
34A	Armature Set For 120V, 50/60 Hz	1	E2DPX10S1568**	7023003		
34	Armature Assembly for 120V, 50/60 Hz	1	E2DPX10S9568**	E2D5508P350		
36	Motor Cover	1	E2DBX10S9569**	E2D509P350		
36B	Wave Washer	1	E2D311125**			
	Wave & Flat Washer Set	1		7023006		
37A	Motor Flange Set	1	E2DBX10S1566***	7023005		
37	Motor Flange	1	E2DBX10S9566***	E2D506P350		
38	Lid Assembly - Pair	1	E2DBX10S1570 – with 14mm brush cap***	E2D1510P350		
39	Carbon Brush	2	E2D502P125	E2D502P350		
40	Name Plate M	1	E2D802P250	E2D802P350		
42	Socket Bolt w/ Spring Washer	4	J1BG20602222 (M6 x 22mm)			
43	Oil Seal	1	E2D221125			
44	Needle Roller Bearing	1	E2D222125			
45	Ball Bearing	2	9000100			
46	Gear #2 Assembly	1	E2D1223250	E2D1223525		
47	Ball Bearing	1	E2D238125	E2D238350		
48	Oil Seal	1	E2D236125	E2D236350		
49	Friction Clutch Assembly (Including Load Sheave)	1	E2D5234400	E2D5234525		
50	Set Spring	1	E2D311125	E2D311350		
51	Oil Seal	1	E2D239125	E2D239350		
52	Gear Cast Packing	1	E2D125125	E2D125350		
53	Gear Case	1	E2D105125	E2D105350		
54	Socket Bolt w/ Spring Washer	4	E2D152125			
55	Controller Cover	1	E2D104125	E2D104350		
56	Name Plate B	1	80580	80581	80582	80583
57	Controller Cover Packing	1	E2D109125	E2D109350		
58	Machine Screw w/ Spring Washer	3	MS554010			
59	Load Chain	Ft.	LCED125NP			
60	Warning Seal EO	1	E2D865125			
61	Warning Seal EE	1	E2D866125			
62	Warning Seal EF	1	E2D867125			

** 6200 (30mm) bearing size Armatures and Motor Covers are no longer available; Replace with new Armature Set E2DPX10S1568 with 6201 (32mm) bearing size.

*** Older Lid Assemblies (E2D1510P125) with 15mm brush cap are no longer available; Replace with new Motor Flange Set E2DBX10S15661 with 14mm brush caps.

This Page Intentionally Left Blank

9.2 ED1000V ADDITIONAL PARTS

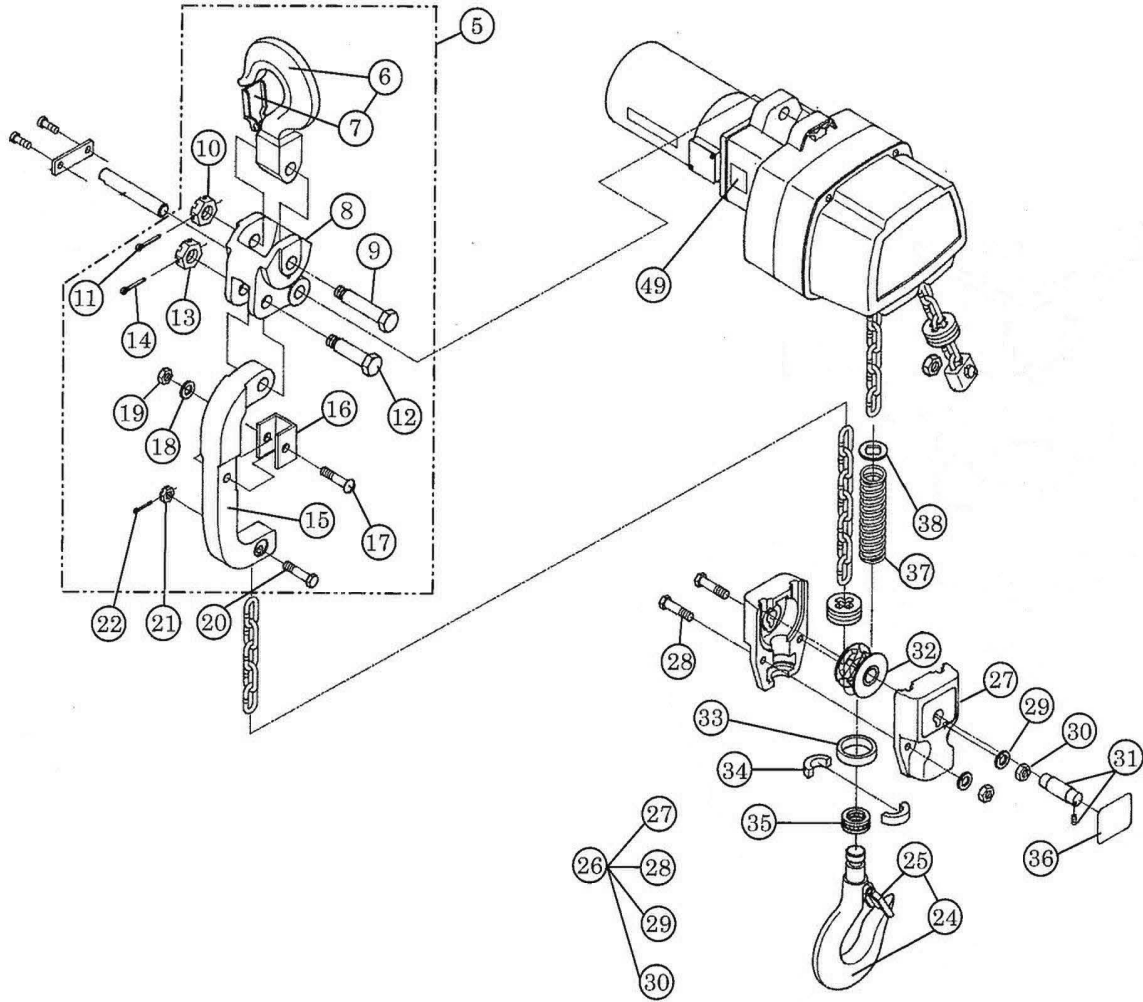

FIGURE 9-2 ED1000V ADDITIONAL PARTS

9.2 ED1000V Additional Parts

Fig. No.	Part Name	Parts Per Hoist	Capacity (lbs.)
			1000
5	Connection Yoke Complete Set	1	E3DBX48S1470
6	Top Hook assembly	1	E3DBX48S6460
7	Hook Latch assembly	1	CF071005
8	Connection Yoke	1	E3DBX48S9470
9	Top Pin, L	1	ES006005L
10	Slotted nut	1	L3183008
11	Split Pin	1	9009403
15	Joint Yoke	1	E3DBX48S9580
16	Protection Pad	1	E3DBX48S9592
17	Truss Head Machine Screw	1	J1AG25003535
18	Washer	1	9012510
19	U nut	1	9098503
20	Chain pin	1	E2D041125
21	Slotted nut	1	E2D041125
22	Split pin	1	9009402
24	Bottom Hook Assembly	1	83056
25	Hook Latch Assembly	1	ER2CS1002
26	Bottom Yoke Assembly	1	E3DBX48S2485
27	Bottom Yoke	2	E3DBX48S9485
28	Bolt	2	9093307
29	Spring Lock Washer	2	9012709
30	Nut	2	9093420
31	Bottom Shaft Assembly	1	E3DBX48S6489
32	Idle Sheave Assembly	1	E3DBX48S6487
33	Thrust Collar A	1	ES026003
34	Hook Stopper	2	ES027003
35	Thrust Bearing	1	ES022003
36	Name Plate C	1	E3DBX48S9597
37	Chain Spring	1	E3DBX48S9590
38	Washer	1	E3DBX48S9591
49	Warning Seal E (Finger protection)	1	E3DBX48S9599
50	Nameplate M (Motor Nameplate)	1	E3DHX48S9802

9.3 Power Supply and Pendant Parts

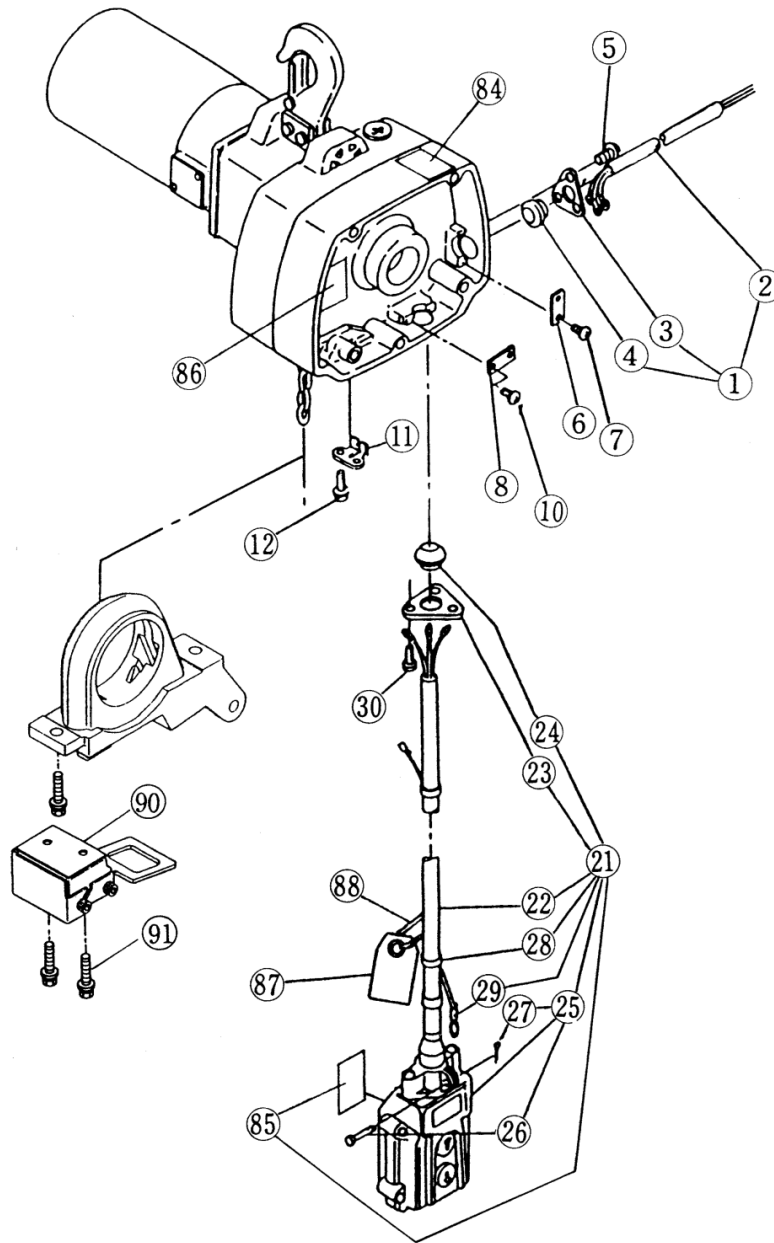
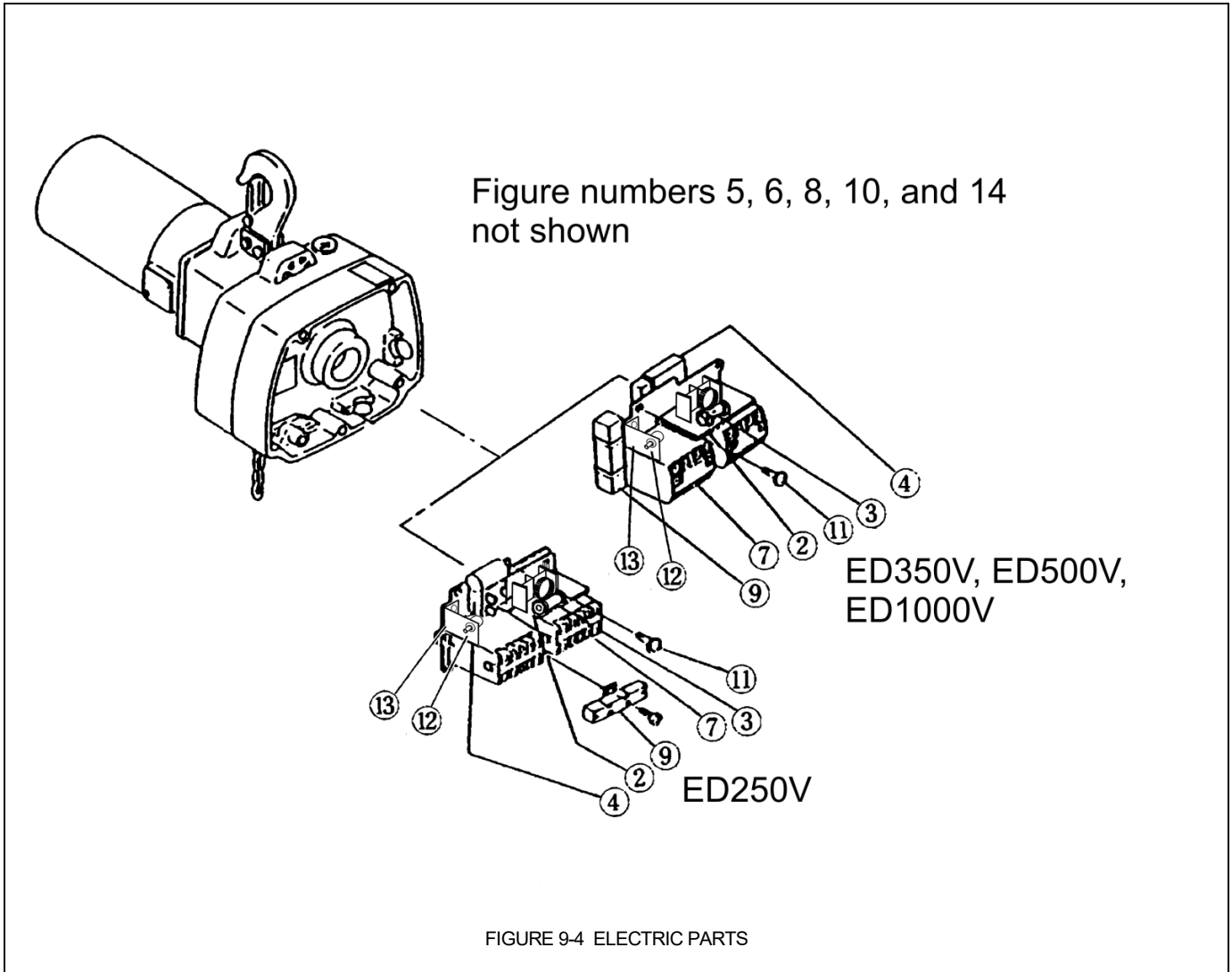

FIGURE 9-3 POWER SUPPLY AND PENDANT PARTS

9.3 Power Supply and Pendant Parts

Fig. No.	Part Name	Parts Per Hoist	Capacity (lbs.)			
			250	350	500	1000
1	Power Supply Cable 3C Complete Set	1	E2D1521125			
2	Power Supply Cable 3C	1	16/3			
3	Cable Holder C	1	E2D537125			
4	Cable Packing C8	1	E2D524125			
5	Machine Screw w/ Spring Washer	3	MS554010			
6	Cable Clamp E8	1	E2D541125			
7	Machine Screw w/ Spring Washer	2	MS556010			
8	Cable Clamp E8	1	E2D541125			
10	Machine Screw w/ Spring Washer	2	MS556010			
11	Cable Support L	1	E2D543125			
12	Machine Screw w/ Spring Washer	2	MS554010			
21	Push Button Cord 3C Complete Set	1	E2D1607P125	E2D1607P350		
22	Push Button Cord 3C	FT	16/3P			
23	Cable Holder C	1	E2D537125			
24	Cable Packing C8	1	E2D524125			
25	Push Button Switch S Assembly	1	E2D1615125			
26	Cord Chain Pin	1	ES628003			
27	Split Pin	1	9009402			
28	Lock-Belt	3	E2D640125			
29	Fixing Sleeve	1	9012301			
30	Machine Screw w/ Spring Washer	3	MS554010			
84	Warning Seal EO	1	E2D865125			
85	Warning Seal EE	1	E2D866125			
86	Warning Seal EF	1	E2D867125			
87	Warning Tag LD	1	E2D931125			
88	Chain Stopper Link	1	E2D045D125			
90	Limit switch	1	E3DBX10S1411	E3DBX24S1411		
91	Socket Bolt w/ Spring Washer	2	J1BG2-0401010			

9.4 Electric Parts



9.4 Electric Parts

Fig. No.	Part Name	Parts Per Hoist	Capacity (lbs.)			
			250	350	525	1000
2	Converter Assembly	1	E2D616PD125	E2D616PD350		
3	Fuse	1	E2D664125	E2D664350		
4	Silicone Stack Assembly	1	E2D622125	E2D622350		
5	Machine Screw w/ Spring Washer (for converter)	2	E2D667125			
6	Machine Screw w/ Spring Washer (for silicone stack)	1	MS557010			
7	Electromagnetic Contactor	2	E2D617P125			
	Electromagnetic Contactor Complete Set	1		E2D617P350		
8	Machine Screw w/ Spring Washer (for Contactor)	4	MS555010			
	Machine Screw w/ Spring Washer (for base)	4		E2D667125		
9	Resistor	1	E2D619P125	E2D619P350		
10	Machine Screw w/ Spring Washer (for Resistor)	9		MS557010		
11	Socket Bolt w/ Spring Washer	3	E2D651125			
		4		E2D651350		
12	Potentiometer	1	E3DBX10S5691			
13	Potentiometer Bracket	1	E3DBX10S9680			
14	Machine Screw for Potentiometer Bracket	2	J1AW24000808			

9.5 Mini Trolley Parts

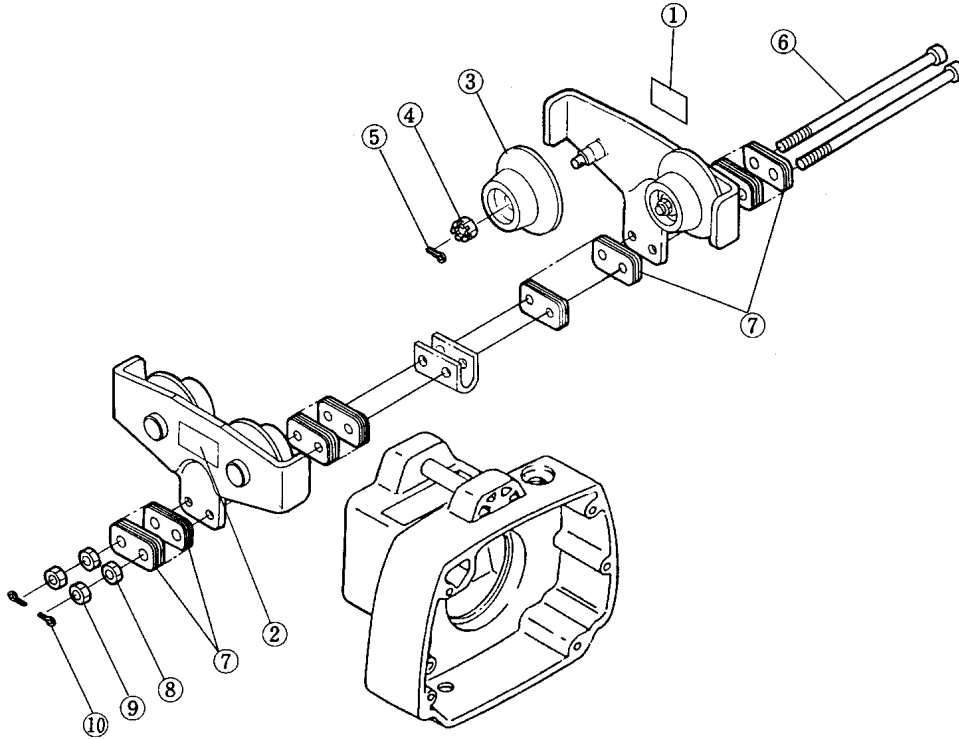

FIGURE 9-5 MINI TROLLEY PARTS

Fig. No.	Part Name	Parts Per Hoist	Capacity (lbs.)		
			250	350	500
1	Name Plate C	1	8058401	8058402	8058403
2	Name Plate B	1	ET25800525		
3	Track Wheel Assembly	4	ET255102525		
4	Slotted Nut	4	M2049010		
5	Split Pin	4	9009411		
6	Socket bolt	2	ET25115525		
7	Adjusting Spacer	32	ET25116525		
8	Nut	2	9093424		
9	U Nut	2	ET25155525		
10	Split Pin	2	9009411		

This Page Intentionally Left Blank

This Page Intentionally Left Blank

This Page Intentionally Left Blank



Harrington Hoists, Inc.
401 West End Avenue
Manheim, PA 17545

www.harringtonhoists.com

Toll Free: 800-233-3010
Phone: 717-665-2000
Fax: 717-665-2861

© HARRINGTON HOISTS, INC.
All Rights Reserved

EDVOM-ENG