
Owner's Manual

MANUAL CHAIN HOIST CB SERIES

MODEL M3

1/2 Ton through 20 Ton Capacity

Code, Lot and Serial Number

WARNING

This equipment should not be installed, operated or maintained by any person who has not read and understood all the contents of this manual. Failure to read and comply with the contents of this manual can result in serious bodily injury or death, and/or property damage.

HARRINGTON
A KITO GROUP COMPANY



Table of Contents

Section	Page Number
1.0 Important Information and Warnings	4
1.1 Terms and Summary	
1.2 Warning Tags and Labels	
2.0 Technical Information.....	7
2.1 Specifications	
2.2 Dimensions	
2.3 Optional Equipment	
3.0 Preoperational Procedures	11
3.1 Chain	
3.2 Attachment Points	
3.3 Mounting the Hoist	
3.4 Preoperational Checks and Trial Operation	
4.0 Operation	13
4.1 Introduction	
4.2 Shall's and Shall Not's for Operation	
4.3 Operation	
4.4 Principal and Operation of the Slip Clutch	
5.0 Inspection	16
5.1 General	
5.2 Inspection Classification	
5.3 Frequent Inspection	
5.4 Periodic Inspection	
5.5 Occasionally Used Hoists	
5.6 Inspection Records	
5.7 Inspection Methods and Criteria	

Section

Page Number

6.0	Maintenance & Handling	26
6.1	Lubrication	
6.2	Disassembly, Assembly and Adjustment	
6.3	Hoist Disassembly	
6.4	Hoist Assembly	
6.5	Storage	
6.6	Outdoor Installation	
7.0	Troubleshooting	37
8.0	Warranty	40
9.0	Parts List	41

1.0 Important Information and Warnings

1.1 Terms and Summary

This manual provides important information for personnel involved with the installation, operation and maintenance of this product. Although you may be familiar with this or similar equipment, it is strongly recommended that you read this manual before installing, operating, or maintaining the product.

Danger, Warning, Caution, and Notice

Throughout this manual there are steps and procedures that can present hazardous situations. The following signal words are used to identify the degree or level of hazard seriousness.

⚠ DANGER Danger indicates an imminently hazardous situation which, if not avoided, **will** result in **death or serious injury**, and property damage.

⚠ WARNING Warning indicates an imminently hazardous situation which, if not avoided, **could** result in **death or serious injury**, and property damage.

⚠ CAUTION Caution indicates a potentially hazardous situation which, if not avoided, **may** result in **minor or moderate injury** or property damage.

NOTICE Notice is used to notify people of installation, operation, or maintenance information which is important but not directly hazard-related.

⚠ CAUTION

These general instructions deal with the normal installation, operation, and maintenance situations encountered with the equipment described herein. The instructions should not be interpreted to anticipate every possible contingency or to anticipate the final system, crane, or configuration that uses this equipment. For systems using the equipment covered by this manual, the supplier and owner of the system are responsible for the system's compliance with all applicable industry standards, and with all applicable federal, state, and local regulations/codes.

This manual includes instructions and parts information for a variety of hoist types. Therefore, all instructions and parts information may not apply to any one type or size of specific hoist. Disregard those portions of the instructions that do not apply.

Record your hoist's Code, Lot and Serial Number (see Section 9) on the front cover of this manual for identification and future reference to avoid referring to the wrong manual for information or instructions on installation, operation, inspection, maintenance, or parts.

Use only Harrington authorized replacement parts in the service and maintenance of this hoist.

WARNING

Equipment described herein is not designed for and **MUST NOT** be used for lifting, supporting, or transporting people, or for lifting or supporting loads over people.

Equipment described herein should not be used in conjunction with other equipment unless necessary and/or required safety devices applicable to the system, crane, or application are installed by the system designer, system manufacturer, crane manufacturer, installer, or user.

Modifications to upgrade, rerate, or otherwise alter this equipment shall be authorized only by the original equipment manufacturer.

If a below-the-hook lifting device or sling is used with a hoist, refer to ANSI/ASME B30.9, "Slings" or ANSI/ASME B30.20, "Below-the-Hook Lifting Devices".

Hoists used to handle hot molten material may require additional equipment or devices. Refer to ASTM E2349, "Standard Practice for Safety Requirements in Metal Casting Operations: Sand Preparation, Molding, and Core Making; Melting and Pouring; and Cleaning and Finishing".

Failure to read and comply with any one of the limitations noted herein can result in serious bodily injury or death, and/or property damage.

NOTICE

It is the responsibility of the owner/user to install, inspect, test, maintain, and operate a hoist in accordance with ANSI/ASME B30.16, "Overhead Underhung and Stationary Hoists" and OSHA Regulations. If the hoist is installed as part of a total lifting system, such as an overhead crane or monorail, it is also the responsibility of the owner/user to comply with the applicable ANSI/ASME B30 volume that addresses that type of equipment.

It is the responsibility of the owner/user to have all personnel that will install, inspect, test, maintain, and operate a hoist read the contents of this manual and applicable portions of ANSI/ASME B30.16, "Overhead Underhung and Stationary Hoists" and OSHA Regulations.

If the hoist owner/user requires additional information, or if any information in the manual is not clear, contact Harrington or the distributor of the hoist. Do not install, inspect, test, maintain, or operate this hoist unless this information is fully understood.

A regular schedule of inspection of the hoist in accordance with the requirements of ANSI/ASME B30.16 should be established, and records maintained.

1.2 Warning Tags and Labels

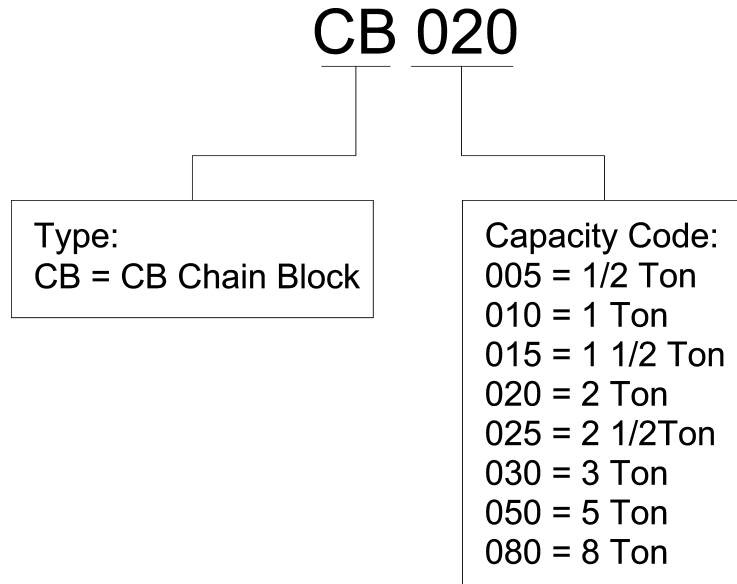
The warning tag illustrated below in Figure 1-1 is supplied with each hoist shipped from the factory. If the tag is not attached to your hoist's hand chain with a chain stopper link, order a tag from your dealer and install it. Read and obey all warnings attached to this hoist. Tag is not shown actual size.



2.0 Technical Information

2.1 Specifications

2.1.1 Product Code



2.1.2 Operating Conditions and Environment

Temperature range: -40° to +140°F (-40° to +60°C)

Humidity: 100% or less (Not an Underwater Device)

Table 2-1 Hoist Specifications								
Cap. (Tons)	Product Code	Std. Lift (ft)	Pull to Lift Load (lbs)	Load Chain Diameter (mm) x Chain Fall Lines	Overhaul Ratio	Net Weight (lbs)	Shipping Weight Approx. (lbs)	Weight for Additional One Foot of Lift (lbs)
½	CB005	8	48	5.0x1	25	22	23	1.0
1	CB010		58	6.3x1	43	25	26	1.2
1½	CB015		70	7.1x1	57	32	33	1.4
2	CB020		72	8.0x1	70	41	43	1.6
2 ½	CB025		66	9.0x1	99	56	58	1.8
3	CB030		72	7.1x2	114	49	53	2.1
5	CB050		68	9.0x2	198	85	89	3.0
8	CB080		75	9.0x3	297	124	131	4.2
10	CB100	12	72	9.0x4	396	186	203	5.5
15	CB150		74	9.0x6	594	346	368	7.9
20	CB200		72x2	9.0x8	396x2	524	678	10.9

*NOTE: Any lift of chain is available on request. Simply specify the length of chain desired when ordering. Because Harrington chains are specially heat treated, only authentic Harrington chains should be used on your hoist. **NEVER** attempt to lengthen the chain by attaching additional chain links to it or by any other means.

2.2 Dimensions

Table 2-2 Hoist Dimensions									
Cap. (Tons)	Product Code	Headroom c (in)	a (in)	b (in)	d (ft)	e (in)	f (in)	g (in)	x (in)
1/2	CB005	11.2	6.2	6.3	8.0	2.7	3.9	1.1	3.5
1	CB010	11.6	6.4	6.3	8.0	2.8	3.9	1.1	4.0
1 1/2	CB015	13.8	6.7	7.2	8.0	3.1	4.4	1.3	4.7
2	CB020	14.8	7.2	8.0	8.0	3.4	4.9	1.4	4.9
2 1/2	CB025	16.5	7.6	9.2	8.0	3.6	5.6	1.6	5.4
3	CB030	20.1	6.7	9.3	8.3	3.1	6.4	1.7	5.8
5	CB050	23.6	7.6	11.1	10.0	3.6	7.6	1.8	6.8
8	CB080	30.3	7.6	14.7	10.3	3.6	10.0	2.9	10.8
10	CB100	29.9	7.6	17.2	14.9	4.4	12.1	2.9	11.6
15	CB150	40.2	10.6	19.4	15.9	4.7	13.3	3.1	12.6
20	CB200	46.5	14.7	29.4	16.3	7.4	14.7	3.2	13.8

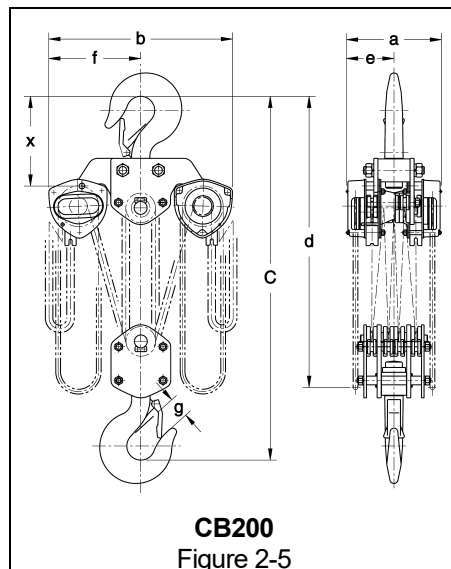
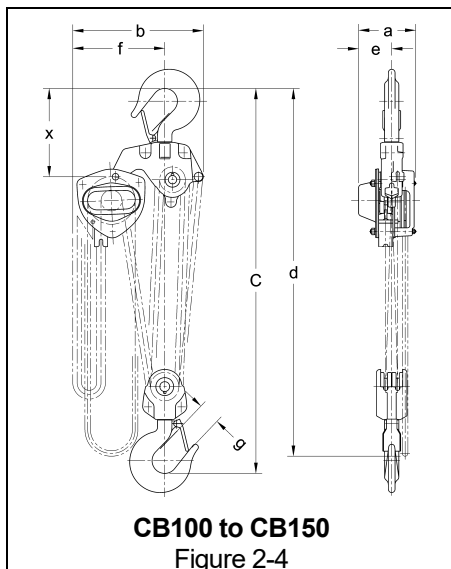
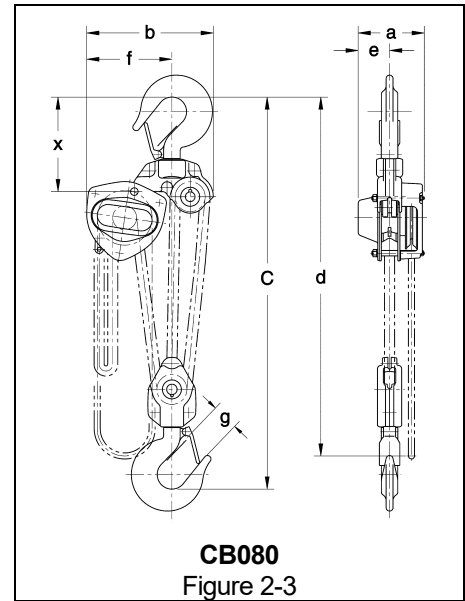
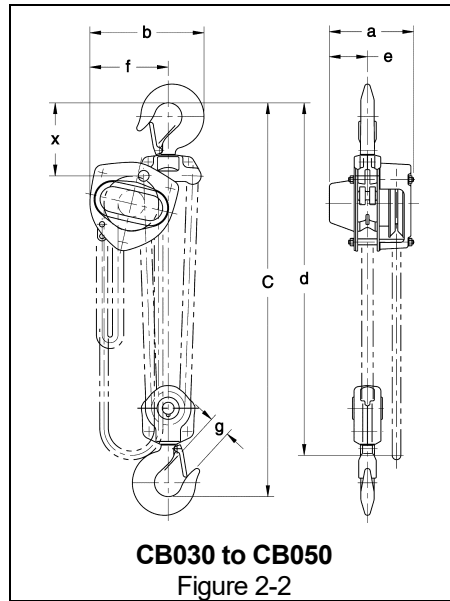
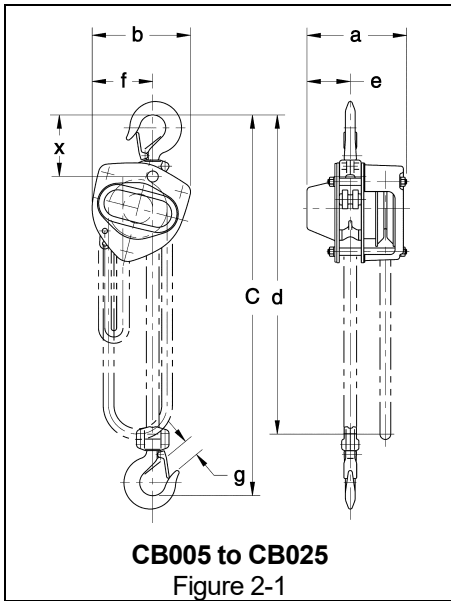
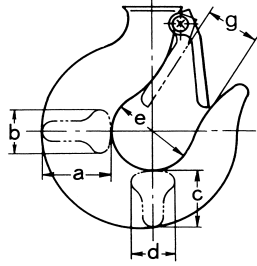


Table 2-3 Hook Dimension*



T = Top Hook
 B = Bottom Hook
 Units = inch

Cap. (Tons)	Product Code	Hook	a	b	c	d	e	g
1/2	CB005	T & B	0.8	0.5	0.7	0.5	1.4	1.1
1	CB010		1.0	0.6	0.9	0.6	1.7	1.1
1½	CB015		1.2	0.8	1.0	0.8	1.9	1.3
2	CB020		1.4	0.9	1.2	0.9	2.0	1.4
2 ½	CB025		1.6	1.0	1.3	1.0	2.1	1.6
3	CB030		1.8	1.1	1.5	1.1	2.2	1.7
5	CB050		2.2	1.4	1.9	1.4	2.5	1.8
8	CB080		3.0	1.9	2.5	1.9	3.3	2.9
10	CB100		3.0	1.9	2.5	1.9	3.3	2.9
15	CB150		3.7	2.4	3.1	2.4	3.9	3.1
20	CB200		4.2	2.6	3.5	2.6	4.3	3.2

*Refer to Section 5.7 for inspection dimensions and limits.

2.3 Optional Equipment

2.3.1 Optional Latch Lock Hooks

- The Bullard® hook has a conventional hook shape with a special, heavy-duty, rotating, spring-loaded, locking latch. The latch remains locked until it is released by the operator. Refer to Figure 2-6.
- The SmartLok™ hook is a special design hook where the latch remains fixed and the hook swings to unlock. The hook cannot be opened while a load is applied. (Note: this type of hook was previously offered as a Shur-Loc®, but was replaced in 2022)
- Installation of these hooks may change the headroom.
- See Section 9.6, Parts List for a complete Latch Lock Hook part listing.
- See Table 6-3 for yoke nut torque specifications.

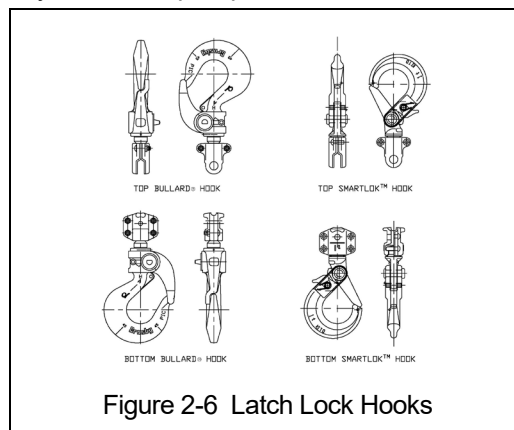


Figure 2-6 Latch Lock Hooks

2.3.2 Optional Inspection Hooks

- The Inspection Hook is designed to facilitate the inspection of the internal surfaces of the hook yoke and shank portion of the hook itself. The Inspection Hook is suitable for applications where inspection of the internal parts of the hook set is required. The inspection hook uses the standard Harrington hook set and is assembled with high-strength locking fasteners instead of rivets. Inspection hooks are available in top and bottom versions. Refer to Figure 2-7.
- Disassembly and re-assembly involves removal and reinstallation of the yoke fasteners of the Inspection Hook Set Assembly followed by testing of the hoist prior to returning it to service.
- The Inspection Hook is available for CB005 through CB025 hoists.
- See Section 9.6, Parts List for a complete Inspection Hook part listing.
- See Table 6-3 for yoke nut torque specifications.

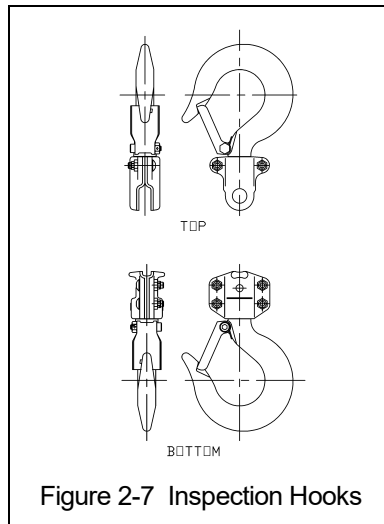


Figure 2-7 Inspection Hooks

2.3.3 Optional Chain Containers

- Chain containers are sized based on the capacity and lift of the hoist. The containers are constructed from vinyl coated canvas with a steel frame on top. The containers are prepared differently depending on the host model. See Section 9.7 Optional Canvas Chain Containers.

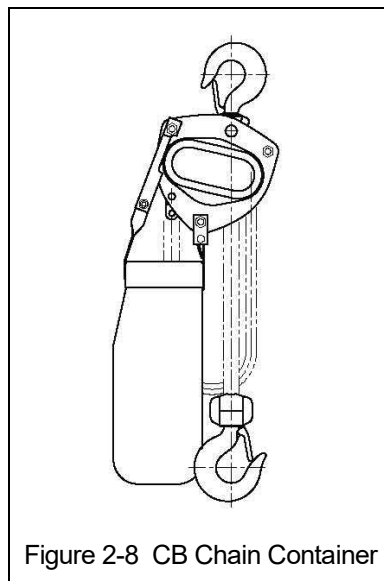
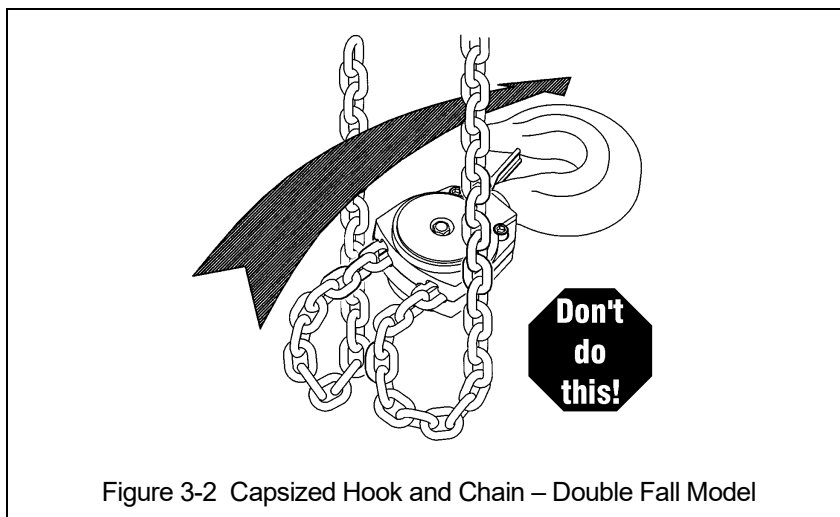
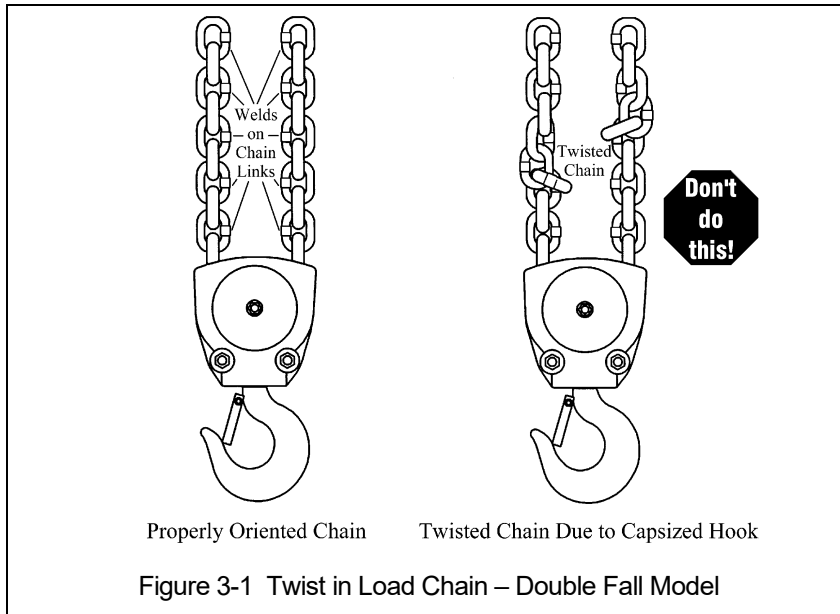


Figure 2-8 CB Chain Container

3.0 Preoperational Procedures

3.1 Chain

- 3.1.1 **⚠ WARNING** Verify that the load chain is not twisted or tangled prior to operating the hoist. Make sure the bottom hook on the 3 Ton (CB030) through the 20 Ton (CB200) Ton multiple chain fall hoists is not capsized. See Figures 3-1 and 3-2. Correct all chain irregularities before conducting the first hoist operation.



3.2 Attachment Points

3.2.1 **⚠️ WARNING** Prior to attaching the hoist ensure that all attachment points, suspension components and supporting structure are adequate to support the hoist and its load. If necessary consult a professional that is qualified to evaluate the adequacy of the suspension location and its supporting structure.

3.2.2 **NOTICE** See Section 6.6 for outdoor installation considerations.

3.3 Mounting the Hoist

3.3.1 Hook Mounted to a Fixed Location - Attach the hoist's top hook to the fixed suspension point.

3.3.2 **⚠️ WARNING** Ensure that the fixed suspension point rests on the center of the hook's saddle and that the hook's latch is engaged.

3.4 Preoperational Checks and Trial Operation

3.4.1 **⚠️ WARNING** Confirm the adequacy of the rated capacity for all slings, chains, wire ropes and all other lifting attachments before use. Inspect all load suspension members for damage prior to use and replace or repair all damaged parts.

3.4.2 **⚠️ WARNING** Verify and correct all chain irregularities prior to operating the hoist. Refer to Section 3.1.

3.4.3 Measure and record the "k" dimension of all hooks on hoist. See Table 5-4 under Section 5, "Inspection".

3.4.4 Record the hoist's Code, Lot and Serial Number (from the nameplate on the hoist; see Section 9) in the space provided on the cover of this manual.

3.4.5 Ensure that the hoist is properly installed to a fixed point.

3.4.6 Ensure that all nuts, bolts and split pins (cotter pins) are sufficiently fastened.

3.4.7 Confirm proper operation.

- Before operating read and become familiar with Section 4 - Operation.
- Before operating ensure that the hoist meets the Inspection, Testing and Maintenance requirements of ANSI/ASME B30.16.
- Before operating ensure that nothing will interfere with the full range of the hoist's operation.

4.0 Operation

4.1 Introduction

DANGER

DO NOT WALK UNDER A SUSPENDED LOAD

WARNING

HOIST OPERATORS SHALL BE REQUIRED TO READ THE OPERATION SECTION OF THIS MANUAL, THE WARNINGS CONTAINED IN THIS MANUAL, INSTRUCTION AND WARNING LABELS ON THE HOIST OR LIFTING SYSTEM, AND THE OPERATION SECTIONS OF ANSI/ASME B30.16 and ANSI/ASME B30.10. THE OPERATOR SHALL ALSO BE REQUIRED TO BE FAMILIAR WITH THE HOIST AND HOIST CONTROLS BEFORE BEING AUTHORIZED TO OPERATE THE HOIST OR LIFTING SYSTEM.

HOIST OPERATORS SHOULD BE TRAINED IN PROPER RIGGING PROCEDURES FOR THE ATTACHMENT OF LOADS TO THE HOIST HOOK.

HOIST OPERATORS SHOULD BE TRAINED TO BE AWARE OF POTENTIAL MALFUNCTIONS OF THE EQUIPMENT THAT REQUIRE ADJUSTMENT OR REPAIR, AND TO BE INSTRUCTED TO STOP OPERATION IF SUCH MALFUNCTIONS OCCUR, AND TO IMMEDIATELY ADVISE THEIR SUPERVISOR SO CORRECTIVE ACTION CAN BE TAKEN.

HOIST OPERATORS SHOULD HAVE NORMAL DEPTH PERCEPTION, FIELD OF VISION, REACTION TIME, MANUAL DEXTERITY, AND COORDINATION.

HOIST OPERATORS SHOULD **NOT** HAVE A HISTORY OF OR BE PRONE TO SEIZURES, LOSS OF PHYSICAL CONTROL, PHYSICAL DEFECTS, OR EMOTIONAL INSTABILITY THAT COULD RESULT IN ACTIONS OF THE OPERATOR BEING A HAZARD TO THE OPERATOR OR TO OTHERS.

HOIST OPERATORS SHOULD **NOT** OPERATE A HOIST OR LIFTING SYSTEM WHEN UNDER THE INFLUENCE OF ALCOHOL, DRUGS, OR MEDICATION.

NOTICE

- Read ANSI/ASME B30.16 and ANSI/ASME B30.10.
- Read the hoist manufacturer's Operating and Maintenance Instructions.
- Read all labels attached to equipment.

The operation of a hoist involves more than activating the hoist's controls. Per the ANSI/ASME B30 standard the use of a hoist is subject to certain hazards that cannot be mitigated by engineered features, but only by the exercise of intelligence, care, common sense, and experience in anticipating the effects and results of activating the hoist's controls. Use this guidance in conjunction with other warnings, cautions, and notices in this manual to govern the operation and use of your hoist.

4.2 Shall's and Shall Not's for Operation

WARNING

Improper operation of a hoist can create a potentially hazardous situation which, if not avoided, could result in death or serious injury, and substantial property damage. To avoid such a potentially hazardous situation **THE OPERATOR SHALL:**

- **NOT** lift more than rated load for the hoist.
- **NOT** use damaged hoist or hoist that is not working properly.
- **NOT** use hoist with twisted, kinked, damaged, or worn chain.
- **NOT** use hoist if the bottom hook is capsized (multiple fall hoists - see Section 3.1).
- **NOT** use the hoist to lift, support, or transport people.
- **NOT** lift loads over people.
- **NOT** apply load unless load chain is properly seated in the load sheave (and idle sheave for hoist with multiple chain falls).
- **NOT** use the hoist in such a way that could result in shock or impact loads being applied to the hoist.
- **NOT** attempt to lengthen the load chain or repair damaged load chain.
- **NOT** operate hoist when it is restricted from forming a straight line from hook to hook in the direction of loading.
- **NOT** use load chain as a sling or wrap load chain around load.
- **NOT** apply load if binding prevents equal loading on all load-supporting chains.
- **NOT** operate beyond the limits of the load chain travel.
- **NOT** support load on hook tip unless hook is designed for tip loading.
- **NOT** use in a way that causes either hook to be side-loaded.
- **NOT** leave load supported by the hoist unattended unless specific precautions have been taken.
- **NOT** allow the chain, or hook to be used as an electrical or welding ground.
- **NOT** allow the chain, or hook to be touched by a live welding electrode.
- **NOT** remove or obscure the warnings on the hoist.
- **NOT** operate a hoist on which the safety placards or decals are missing or illegible.
- Be familiar with operating controls, procedures, and warnings.
- Make sure the unit is securely attached to a suitable support before applying load.
- Make sure load slings or other approved single attachments are properly sized, rigged, and seated in the hook saddle.
- Take up slack carefully - make sure load is balanced and load-holding action is secure before continuing.
- Make sure all persons stay clear of the supported load.
- Protect the hoist's load chain from weld splatter or other damaging contaminants.
- Report Malfunctions or unusual performances (including unusual noises) of the hoist and remove the hoist from service until the malfunction or unusual performance is resolved.
- Warn personnel before lifting or moving a load.
- Warn personnel of an approaching load.

⚠ CAUTION

Improper operation of a hoist can create a potentially hazardous situation which, if not avoided, could result in minor or moderate injury, or property damage. To avoid such a potentially hazardous situation **THE OPERATOR SHALL:**

- Maintain a firm footing or be otherwise secured when operating the hoist.
- Check brake function by tensioning the hoist prior to each lift operation.
- Use hook latches. Latches are to retain slings, chains, etc. under slack conditions only.
- Make sure the hook latches are closed and not supporting any parts of the load.
- Make sure the load is free to move and will clear all obstructions.
- Avoid swinging the load or hook.
- Make sure hook travel is in the same direction as shown on controls.
- Inspect the hoist regularly, replace damaged or worn parts, and keep appropriate records of maintenance.
- Use the hoist manufacturer's recommended parts when repairing the unit.
- Lubricate load chain per hoist manufacturer's recommendations.
- **NOT** use the hoist load limiting or warning device to measure load.
- **NOT** allow your attention to be diverted from operating the hoist.
- **NOT** allow the hoist to be subjected to sharp contact with other hoists, structures, or objects through misuse.
- **NOT** adjust or repair the hoist unless qualified to perform such adjustments or repair.

4.3 Operation

- 1) Face the hand chain wheel side of the hoist.
- 2) To raise the load, pull hand chain clockwise.
- 3) To lower the load, pull hand chain counterclockwise.

NOTE: 2 Operators required for the 20 Ton (CB200) unit.

⚠ WARNING : To prevent a load drop the clicking sound of the pawl engaging the ratchet disc must be present when a load is being raised.

4.4 Principle and Operation of the Slip Clutch

⚠ WARNING : IMPROPER chain hoist use could result in death or serious injury. To avoid these hazards:

⚠ WARNING : NEVER disassemble or attempt to adjust the slip clutch assembly. Any attempt to do so will void the warranty. Contact your closest Harrington Distributor if service is required.

The standard slip clutch device prevents the hoist from being used to lift damaging loads beyond the rated capacity of the manual chain hoist. When an applied load exceeds the preset value, the hand chain wheel rotates idly. The mechanism is a friction clutch system located between the hand chain wheel and the mechanical brake.

5.0 Inspection

5.1 General

- 5.1.1 The inspection procedure herein is based on ANSI/ASME B30.16. The following definitions are from ANSI/ASME B30.16 and pertain to the inspection procedure below.
- **Designated Person** – a person selected or assigned as being competent to perform the specific duties to which he/she is assigned.
 - **Qualified Person** – a person who, by possession of a recognized degree or certificate of professional standing, or who, by extensive knowledge, training, and experience, has successfully demonstrated the ability to solve or resolve problems relating to the subject matter and work.
 - **Normal Service** – that distributed service which involves operation with randomly distributed loads within the rated load limit, or uniform loads less than 65% of rated load for not more than 15% of the time.
 - **Heavy Service** – that service which involves operation within the rated load limit which exceeds normal service.
 - **Severe Service** – that service which involves normal or heavy service with abnormal operating conditions.

5.2 Inspection Classification

- 5.2.1 Initial Inspection – prior to initial use, all new, altered, or modified hoists shall be inspected by a designated person to ensure compliance with the applicable provisions of this manual.
- 5.2.2 Inspection Classification – the inspection procedure for hoists in regular service is divided into two general classifications based upon the intervals at which inspection should be performed. The intervals in turn are dependent upon the nature of the critical components of the hoist and the degree of their exposure to wear, deterioration, or malfunction. The two general classifications are herein designated as FREQUENT and PERIODIC, with respective intervals between inspections as defined below.
- 5.2.3 FREQUENT Inspection – visual examinations by the operator or other designated personnel with intervals per the following criteria:
- Normal service – monthly
 - Heavy service – weekly to monthly
 - Severe service – daily to weekly
 - Special or infrequent service – as recommended by a qualified person before and after each occurrence.
- 5.2.4 PERIODIC Inspection – visual inspection by a designated person with intervals per the following criteria:
- Normal service – yearly
 - Heavy service – semiannually
 - Severe service – quarterly
 - Special or infrequent service – as recommended by a qualified person before the first such occurrence and as directed by the qualified person for any subsequent occurrences.

5.3 Frequent Inspection

5.3.1 Inspections should be made on a FREQUENT basis in accordance with Table 5-1, "Frequent Inspection." Included in these FREQUENT Inspections are observations made during operation for any defects or damage that might appear between Periodic Inspections. Evaluation and resolution of the results of FREQUENT Inspections shall be made by a designated person such that the hoist is maintained in safe working condition.

Table 5-1 Frequent Inspection
All functional operating mechanisms for proper operation and adjustment, maladjustment and unusual sounds.
Hoist braking system for proper operation
Hooks and latches in accordance with ANSI/ASME B30.10
Hook latch operation
Load chain in accordance with Section 5.7
Load chain reeving for compliance with Section 3.1 and 6.4
Hoist support for damage

5.4 Periodic Inspection

- 5.4.1 Inspections should be made on a PERIODIC basis in accordance with Table 5-2, "Periodic Inspection." Evaluation and resolution of the results of PERIODIC Inspections shall be made by a designated person such that the hoist is maintained in safe working condition.
- 5.4.2 For inspections where load suspension parts of the hoist are disassembled, a load test per ANSI/ASME B30.16 must be performed on the hoist after it is re-assembled and prior to its return to service.

Table 5-2 Periodic Inspection
Requirements of frequent inspection.
Evidence of loose bolts, nuts, or rivets.
Evidence of worn, corroded, cracked, or distorted parts such as load blocks, suspension housing, chain attachments, clevises, yokes, suspension bolts, shafts, gears, bearings, pins, rollers and locking and clamping devices.
Evidence of damage to hook retaining nuts or collars and pins, and welds or rivets used to secure the retaining members.
Evidence of damage or excessive wear of load and idler sheaves.
Evidence of worn, glazed or oil contaminated friction disks; worn pawls, cams or ratchet; corroded, stretched, or broken pawl springs in brake mechanism.
Evidence of damage to supporting structure.
Function label on hoist for legibility.
Warning label properly attached to the hoist and legible (see Section 1.2).
End connection of load chain.

5.5 Occasionally Used Hoists

5.5.1 Hoists that are used infrequently shall be inspected as follows prior to placing in service:

- Hoist Idle More Than 1 Month, Less Than 1 Year: Inspect per FREQUENT Inspection criteria in Section 5.3.
- Hoist Idle More Than 1 Year: Inspect per PERIODIC Inspection criteria in Section 5.4.

5.6 Inspection Records

5.6.1 Dated inspection reports and records should be maintained at time intervals corresponding to those that apply for the hoist's PERIODIC interval per Section 5.2.4. These records should be stored where they are available to personnel involved with the inspection, maintenance, or operation of the hoist.

5.6.2 A long range chain inspection program should be established and should include records of examination of chains removed from service so a relationship can be established between visual observation and actual condition of the chain.

5.7 Inspection Methods and Criteria

5.7.1 This section covers the inspection of specific items. The list of items in this section is based on those listed in ANSI/ASME B30.16 for the Frequent and Periodic Inspection.

5.7.2 Frequent Inspection - Not intended to involve disassembly of the hoist. Disassembly for further inspection would be required only if frequent inspection results so indicate. Disassembly and further inspection should only be performed by a qualified person trained in the disassembly and re-assembly of the hoist.

5.7.3 Periodic Inspection - Disassembly of the hoist is required. Disassembly should only be performed by a qualified person trained in the disassembly and re-assembly of the hoist.

Table 5-3 Hoist Inspection Methods and Criteria

Item	Method	Discard Limit/Criteria	Action
Functional operating mechanisms.	Visual, Auditory	Mechanisms should be properly adjusted and should not produce unusual sounds when operated. Components should not be deformed, scarred, or show significant wear. Refer to Figures 5-2, 5-3 and 5-4.	Repair or replace as required.
Hooks – Stretch	Measure	The "k" dimension should not be greater than 1.05 times that measured and recorded at the time of purchase (See Section 3.4). If recorded "k" values are not available for hooks when new, use nominal "k" values from Table 5-4.	Replace.
Hooks – Fretting wear	Measure	The "u" and "t" dimensions should not be less than discard value listed in Table 5-4.	Replace.
Hooks – Surface Condition	Visual	Should be free of gouges, deep nicks, dents, weld splatter, and significant corrosion.	Replace.
Hooks – Deformation	Visual	Should be free of twists and deformations. See Figure 5-1.	Replace.
Hooks – Bent Shank or Neck	Visual	Shank and neck portions of hook should be free of deformations.	Replace.
Hooks – Swivel	Visual, Function	Bearing parts and surfaces should not show significant wear, and should be free of dirt, grime, and deformations. Hook should rotate freely with no roughness. See Figure 5-1.	Clean/lubricate, or replace as required.

Table 5-3 Hoist Inspection Methods and Criteria			
Item	Method	Discard Limit/Criteria	Action
Hooks – Yoke Assembly	Visual	Should be free of significant rust, weld splatter, nicks, and gouges. Holes should not be elongated, fasteners should not be loose, and there should be no gap between mating parts.	Tighten or replace as required.
Hooks – Idle Sheave and Shaft (Multiple Fall Hoist)	Visual, Function	Pockets of Idle Sheave should be free of significant wear. Idle Sheave surfaces should be free of nicks, gouges, dirt, and grime. Bearing parts and surfaces of Idle Sheave and Axle should not show significant wear. Idle Sheave should rotate freely with no roughness or significant free play.	Clean/lubricate, or replace as required.
Hooks – Hook Latches	Visual, Function	Latch should not be deformed. Attachment of latch to hook should not be loose. Latch spring should not be missing and should not be weak. Latch movement should not be stiff - when depressed and released latch should snap smartly to its closed position.	Replace.
Yoke – Top Pin Hole Deformation	Visual, Measure	The "d" dimension of the top pin hole should not be greater than the discard value listed in Table 5-5.	Replace Hook Set
Top Pin – Deformation	Visual, Measure	The pin should be free of scars or significant deformation. The "d" dimension should not be less than discard value listed in Table 5-6.	Replace
Yoke – Chain Pin Hole Deformation	Measure	The "d" dimension of the chain pin hole should not be greater than the discard value listed in Table 5-5.	Replace Hook Set or yoke.
Chain Pin – Deformation	Visual, Measure	The pin should be free of scars or significant deformation. The "d" dimension should not be less than discard value listed in Table 5-7.	Replace
Load Chain – Pitch and Wire Diameter	Measure	The "P" dimension should not be greater than discard value listed in Table 5-8. The "d" dimension should not be less than discard value listed in Table 5-8.	Replace. Inspect Load Sheave (and Idle Sheave for multiple fall hoists).
Load Chain – Surface Condition	Visual	Should be free of gouges, nicks, dents, weld splatter, and corrosion. Links should not be deformed, and should not show signs of abrasion. Surfaces where links bear on one another should be free of significant wear.	Replace.
Load Chain – Lubrication	Visual, Auditory	Entire surface of each chain link should be coated with lubricant and should be free of dirt and grime. Chain should not emit cracking noise when hoisting a load.	Clean/lubricate (see Section 6.0).
Load Chain – Reeving	Visual	Chain should be reeved properly through Load Sheave. On multiple fall hoists chain should be installed properly and free of twists. Refer to Section 3.1.	Reeve/Install chain properly.
Lifting System – Components	Visual, Function	Components should not be deformed, scarred, or show significant wear.	Replace.

Table 5-3 Hoist Inspection Methods and Criteria

Item	Method	Discard Limit/Criteria	Action
Braking System – Components	Visual	Brake Pawl, Pawl Pin, and Pawl Spring should not be deformed, scarred, or show significant wear. Refer to Figure 5-2 (33 & 32).	Replace.
Brake – Damage to Brake Surface	Visual	Damage due to scratching or gouging by foreign matter. Refer to Figure 5-2 (36, 37, & 41).	Replace.
Braking System – Friction Disc	Visual	The surface of the friction plate should be free of scars, gouges, and wear. Refer to Figure 5-2 (35).	Replace.
Braking System – Friction Plate	Visual, Measure	The surface of the friction plate should be free of grease, oil, scars, gouges and wear and have uniform thickness. The outer thickness should not be thinner than the inner thickness. The thickness should not be less than the discard value listed in Table 5-9.	Replace.
Braking System – Bushing	Measure	The bushing should have uniform thickness. The “t” dimension should not be less than the discard value listed in Table 5-10.	Replace.
Braking System – Bushing	Visual	When slightly heated, the bushing should be so lubricated that lubricant oozes off the surface. Refer to Figure 5-2 (38). Type of oil to be used: ISO VG68 or equivalent.	Soak bushing in machine oil for one day.
Braking System – Ratchet Disc	Measure	The “D” dimension should not be less than the discard value listed in Table 5-11. Refer to Figure 5-2 (37).	Replace.
Load Sheave	Visual	Pockets of Load Sheave should be clean and free of significant wear. Refer to Figure 5-3 (15).	Replace.
Load Gear	Visual	Teeth have excessive wear or damage. Refer to Figure 5-4 (25).	Replace.
Hand Wheel	Visual	Large wear or deformation on the surface of hand wheel. The hand wheel touches the cover.	Replace.
Frame and Mechanical Components	Visual, Auditory, Function	Hoist components including load blocks, suspension frame, chain attachments, clevises, yokes, suspension bolts, shafts, gears, bearings, stripper, pins, and rollers should be free of cracks, distortion, significant wear, and corrosion. Evidence of same can be detected visually or via detection of unusual sounds during operation. Refer to Figures 5-4 & 5-5.	Replace.
Chain Guide	Visual	Excessive wear or press mark.	Replace.
Bolts, Nuts and Rivets	Visual, Check with Proper Tool	Bolts, nuts, and rivets should not be loose, deformed, or corroded.	Tighten or replace as required.
Warning Labels	Visual	Warning Labels should be affixed to the hoist (see Section 1.2) and they should be legible.	Replace.
Hoist Capacity Label	Visual	The label that indicates the capacity of the hoist should be legible and securely attached to the hoist.	Replace.

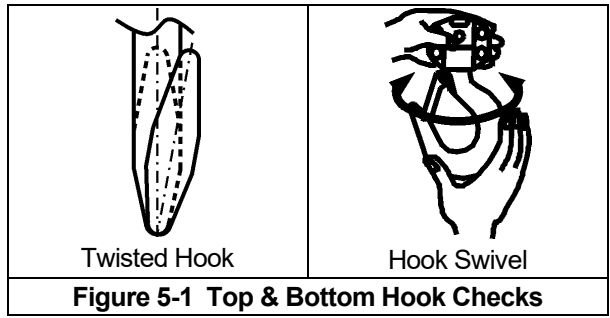


Table 5-4 Top Hook & Bottom Hook Dimensions

“k” Measured When New:
 Top: _____
 Bottom: _____

“k” Discard value = recorded “k” dimension multiplied by 1.05

Product Code	Nominal “k” Dimension* inch (mm)	“u” Dimension inch (mm)		“t” Dimension inch (mm)	
		Standard	Discard	Standard	Discard
CB005	1.76 (44.6)	0.67 (17.0)	0.60 (15.3)	0.48 (12.1)	0.43 (10.9)
CB010	1.92 (48.8)	0.86 (21.8)	0.77 (19.6)	0.63 (16.0)	0.57 (14.4)
CB015	2.22 (56.3)	1.04 (26.5)	0.94 (23.9)	0.77 (19.5)	0.69 (17.6)
CB020	2.36 (59.9)	1.18 (30.0)	1.06 (27.0)	0.86 (21.8)	0.77 (19.6)
CB025	2.52 (64.1)	1.32 (33.5)	1.19 (30.2)	0.96 (24.3)	0.86 (21.9)
CB030	2.72 (69.1)	1.48 (37.5)	1.33 (33.8)	1.07 (27.2)	0.97 (24.5)
CB050	3.06 (77.8)	1.87 (47.5)	1.69 (42.8)	1.36 (34.5)	1.22 (31.1)
CB080	4.56 (115.9)	2.48 (63.0)	2.23 (56.7)	1.87 (47.5)	1.69 (42.8)
CB100	4.56 (115.9)	2.48 (63.0)	2.23 (56.7)	1.87 (47.5)	1.69 (42.8)
CB150	5.52 (140.2)	3.15 (80.0)	2.84 (72.0)	1.97 (50.0)	1.77 (45.0)
CB200	5.62 (142.8)	3.54 (90.0)	3.19 (81.0)	2.21 (56.0)	2.09 (53.1)

*These values are nominal since the dimension is not controlled to a tolerance. The “k” dimension should be measured when the hook is new - this becomes a reference measurement. Subsequent measurements are compared to this reference to make determinations about hook deformation/stretch. See Section 5.7, “Hooks - Stretch”.

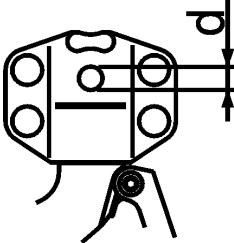
Table 5-5 Chain Pin Hole and Top Pin Hole Wear Dimensions				
				
Product Code	Hole Diameter (d)			
	Chain Pin Hole inch (mm)		Top Pin Hole inch (mm)	
	Standard	Discard	Standard	Discard
CB005	0.252 (6.4)	0.272 (6.9)	0.480 (12.2)	0.500 (12.7)
CB010	0.319 (8.1)	0.339 (8.6)	0.480 (12.2)	0.500 (12.7)
CB015	0.350 (8.9)	0.370 (9.4)	0.638 (16.2)	0.658 (16.7)
CB020	0.394 (10.0)	0.413 (10.5)	0.638 (16.2)	0.658 (16.7)
CB025	0.445 (11.3)	0.465 (11.8)	0.638 (16.2)	0.658 (16.7)
CB030	0.350 (8.9)	0.370 (9.4)	0.646 (16.4)	0.665 (16.9)
CB050, CB080, CB100	0.445 (11.3)	0.465 (11.8)	0.646 (16.4)	0.665 (16.9)
CB150	0.445 (11.3)	0.465 (11.8)	0.638 (16.2)	0.658 (16.7)
CB200	N/A	N/A	0.638 (16.2)	0.658 (16.7)


Table 5-6 Body Top Pin Wear Dimensions		
		
Product Code	"d" Dimension inch (mm)	
	Standard	Discard
CB005, CB010	0.472 (12)	0.433 (11)
CB015, CB020, CB025, CB030, CB050, CB080, CB100, CB150, CB200	0.630 (16)	0.591 (15)

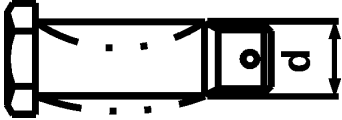
Table 5-7 Chain Pin Wear Dimensions		
		
Product Code	"d" Dimension inch (mm)	
	Standard	Discard
CB005	0.244 (6.2)	0.232 (5.9)
CB010	0.311 (7.9)	0.295 (7.5)
CB015, CB030	0.343 (8.7)	0.327 (8.3)
CB020	0.386 (9.8)	0.370 (9.4)
CB025, CB050, CB080, CB100, CB150	0.437 (11.1)	0.417 (10.6)

Table 5-8 Chain Wear Dimensions				
Product Code	"P" Dimension inch (mm)		"d" Dimension inch (mm)	
	Standard	Discard	Standard	Discard
CB005	2.97 (75.5)	3.06 (77.7)	0.20 (5.0)	0.18 (4.5)
CB010	3.76 (95.5)	3.87 (98.3)	0.25 (6.3)	0.22 (5.7)
CB015, CB030	4.17 (106.0)	4.30 (109.1)	0.28 (7.1)	0.25 (6.4)
CB020	4.76 (121.0)	4.91 (124.6)	0.32 (8.0)	0.28 (7.2)
CB025, CB050, CB080, CB100, CB150, CB200	5.35 (136.0)	5.51 (140.0)	0.35 (9.0)	0.32 (8.1)

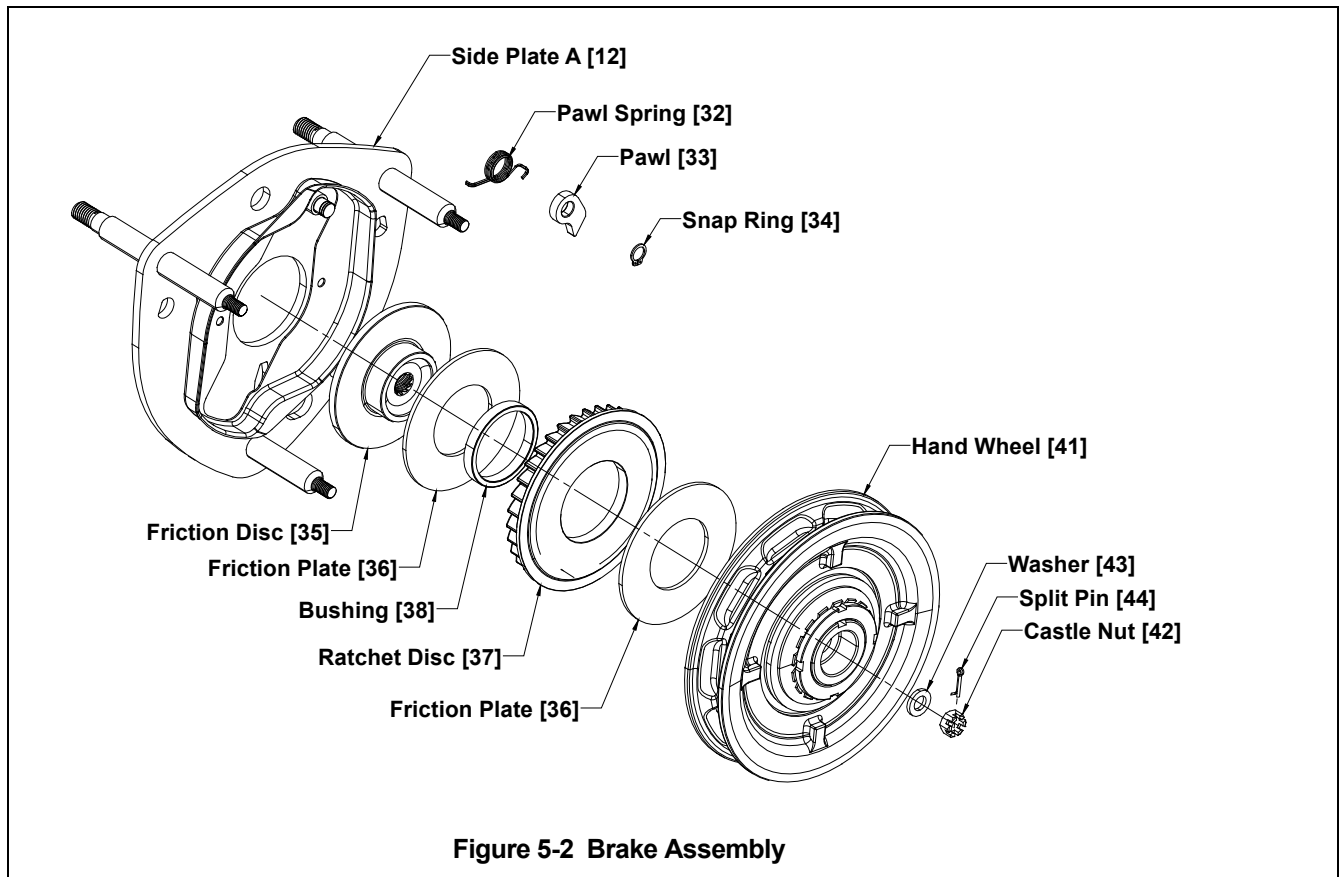


Figure 5-2 Brake Assembly

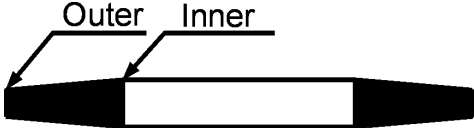
Table 5-9 Friction Plate Wear Dimensions		
		
Product Code	Thickness inch (mm)	
	Standard	Discard
All	0.118 (3.0)	0.098 (2.5)

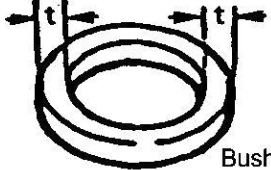
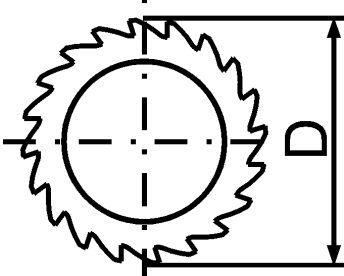
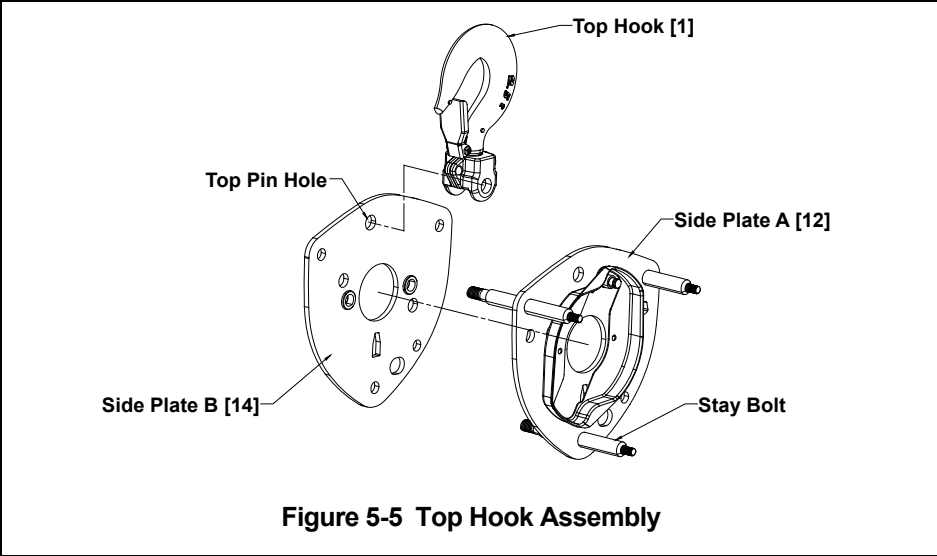
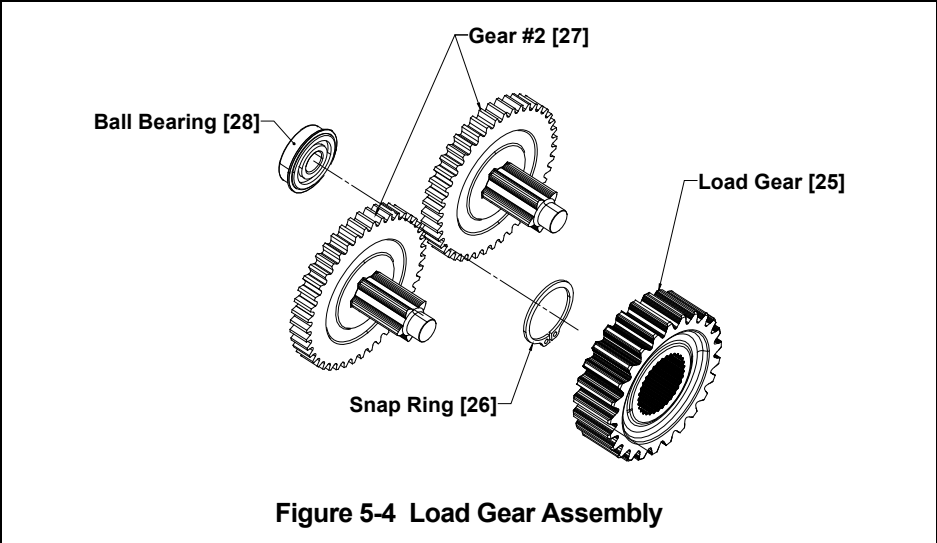
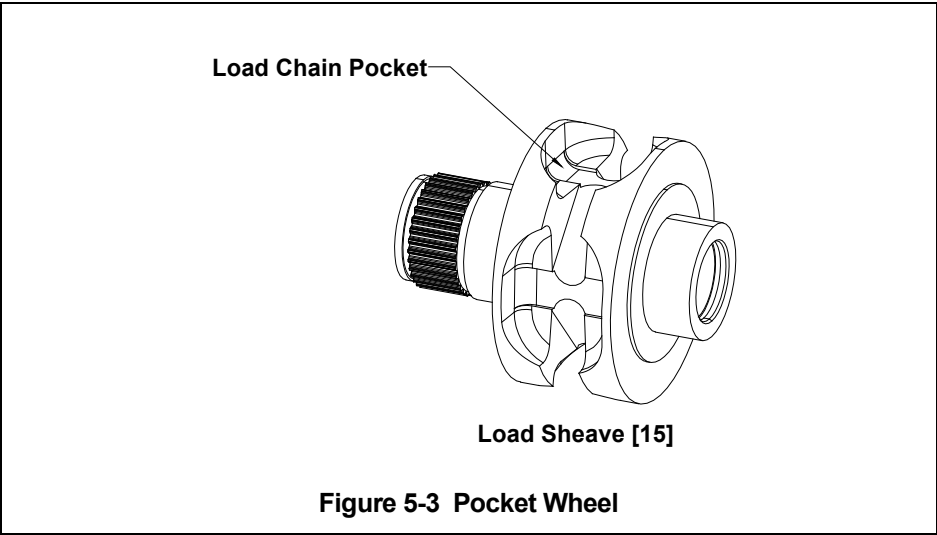
Table 5-10 Brake Bushing Wear Dimensions		
 <p>Bushing [38]</p> <p>t: Radial thickness</p>		
Product Code	A Dimension inch (mm)	
	Standard	Discard
CB005, CB010, CB015, CB030	0.118 (3.0)	0.079 (2.0)
CB020, CB025, CB050, CB080, CB100, CB150, CB200	0.157 (4.0)	0.118 (3.0)

Table 5-11 Brake Ratchet Disc Wear Dimensions		
		
Product Code	D Dimension inch (mm)	
	Standard	Discard
CB005, CB010, CB015, CB030	2.71 (69)	2.60 (66)
CB020	3.23 (82)	3.11 (79)
CB025, CB050, CB080, CB100, CB150, CB200	4.65 (118)	4.53 (115)

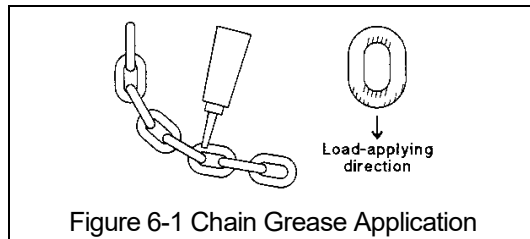


6.0 Maintenance and Handling

6.1 Lubrication

6.1.1 Load Chain

- For longer life, the load chain should be lubricated.
- The load chain lubrication should be accomplished after cleaning the load chain with an acid free cleaning solution.
- Apply Harrington lubricating grease (Part No. ER1BS1951) or an equivalent to industrial general lithium grease, NLGI No. 0, to the bearing surfaces of the load chain links as indicated by the shaded areas in Figure 6-1. Also apply the grease to the areas of the load chain (shaded areas in Figure 6-1) that contact the load sheave. Insure that the grease is applied to the contact areas in the load sheave pockets.
- Machine or gear oil (grade ISO VG 46 or 68 oil or equivalent) may be used as an alternative lubricant but must be applied more frequently.



- The chain should be lubricated every 3 months (more frequently for heavier usage or severe conditions).
- For dusty environments, it is acceptable to substitute a dry lubricant.

6.1.2 Hooks and Suspension Components:

- Hooks – Bearings should be cleaned and lubricated at least once per year for normal usage. Clean and lubricate more frequently for heavier usage or severe conditions.
- Hook Yokes and Latches – Lubricate the hook yokes and hook latches at least twice per year for normal usage; more frequently for heavier usage or severe conditions.
- Suspension Pins - Lubricate the chain pin and the top pin at least twice per year for normal usage; more frequently for heavier usage or severe conditions.

6.1.3 Applying Grease to Gears:

- Remove gear case as instructed in Section 6.3.
- Remove old grease and replace the new grease (NLGI No. 3), at annual inspection.

Table 6-1 General Lubrication			
Parts to be Lubricated	Name of Oil	Amount of Lubrication and Lubricating Method	Frequency of Lubrication
Mechanical Brake Parts: Ratchet Disc, Pawl Pin, Screw parts of Pinion	Machine or Gear Oil	Wipe off oil with waste cloth after applying proper amount of oil.	When the hand pull becomes extremely heavy in lowering operations.

6.2 Disassembly, Assembly and Adjustment

6.2.1 **NOTICE**

- 1) Perform proper disassembly or assembly in accordance with this manual.
- 2) The hoist utilizes dry friction plates; they are not to be lubricated.
- 3) Do not extend the load chain.
- 4) Remove old grease on the disassembled parts.
- 5) Replace components with Harrington Hoist approved parts.
- 6) To reassemble, apply new grease, and use a new split pin and snap ring.

6.2.2 Tools – The following tools are required to disassemble/reassemble the hoist.

No.	Tool	Operation
1	Snap ring pliers	Opening a snap ring
2	Metric socket wrenches	Slotted nuts
3	Metric hex keys (Allen wrenches)	Socket head cap screws
4	Metric wrenches	Bolts and nuts
5	Phillips screwdriver	Machine screws
6	Pliers (Needle Nose)	Split pins
7	Soft-face (Dead blow) hammer	
8	Wooden Blocks	Elevate hoist

6.3 Hoist Disassembly

Proceed as follows (**Note: Figures in brackets are Figure Numbers in Parts List**):

- 1) Orient a hoist with wheel cover side up.
- 2) Unscrew three nuts [46] (with the spring washers [47]) fixing the wheel cover [45] and remove the wheel cover from the side plate A [12].
- 3) Remove the hand chain [49] from the hand wheel [41].
- 4) With overload Limiter - Pull out the split pin [44] from the castle nut [42]. Remove the castle nut (left-handed threads) and the washer [43] from the threaded pinion shaft.
- 4a) Without OLL (optional) – Pull out the split pin [44] from the wheel stopper pin [43] and remove the wheel stopper pin and the wheel stopper [42] from the pinion [40].
- 5) Remove the hand wheel [41] from the pinion [40] by turning the hand wheel counterclockwise.
***NOTE:** If the hand wheel is too tight to turn by hand, put the hand chain back on the hand wheel and pull it down hard. It will release the brake.
- 6) Remove two friction plates [36], the ratchet disc [37] and the bushing [38] from the friction disc [35].
- 7) Unscrew the friction disc [35] from the pinion [40] by turning counterclockwise holding the end of the pinion with your fingers.
- 8) Remove the snap ring [34] from the pawl pin (on the side plate A) and then remove the pawl [33] and pawl spring assembly [32].

9) For 8 ton capacity and under:

Pull the split pin [24] out from the stopper pin [23] and remove the load chain [48] and the stopper pin from the anchorage [22].

10) For 10 ton capacity and above:

Pull the split pin [54] out from the end pin [53] and remove the load chain [48] and the end pin. Unscrew two socket bolts (with the spring washers) fixing the stopper(s) [114] and remove the stopper(s).

11) Remove the load chain [48] from the load sheave [15] by pulling the load chain toward the bottom hook.

12) Remove the split pin [5] from the top pin [4], then remove the top pin and the top hook [1] from the side Plate A [12] and B [14].

13) Place hoist with gear case [29] side up.

14) Unscrew three nuts [30] (with the spring washers [31]) fixing the gear case [29], remove the gear case from the side plate B [14], and remove the ball bearing [28] from the gear case.

15) Remove the two gear #2 [27] (1/2T has one) from the side plate B [14].

16) Remove the snap ring [26] from the load sheave [15], then the load gear [25] from the load sheave.

17) Remove the side plate B [14] from the side plate A [12] and then take the ball bearing [17] out from the side plate B.

18) Remove the two guide rollers [20], load sheave (attached to the pinion [40]), stripper [21] and the anchorage (stopper) [22] (for 10 Ton capacity and above: cross guide [55]) from the side plate A [12], then remove the ball bearing [16] from the side plate A.

19) Remove the snap ring [19] in the load sheave [15].

20) Remove the pinion [40] and the roller bearing [18] from the load sheave [15].

***NOTE:** Hold the load sheave by hand and remove the bearing by tapping the pinion with a rubber mallet.

21) Pull the split pin [10] out from the slotted nut [9] and remove the slotted nut and chain pin from the bottom hook [6].

6.4 Hoist Assembly

6.4.1 **⚠ WARNING**

- Inspect and replace any worn or damaged parts per Table 5-3.
- Tighten yoke nuts to torque specifications in Table 6-3. Secure all other nuts, bolts, and split pins firmly unless otherwise noted.
- Replace all split pins and retaining rings.

6.4.2 Assembly

1) Apply grease to the rollers of the roller bearing [18] and insert the pinion [40] (from the side of the brake screw) into the roller bearing and insert them together into the load sheave [15]. Fix them with a snap ring [19].

***NOTE:** The arrow* on the outer side of the roller bearing should face the gear side. When inserting, use a screwdriver on the bearing and tap it with a rubber mallet. See Fig. 6-1.

⚠ WARNING : Always make sure that the snap ring is correctly seated.

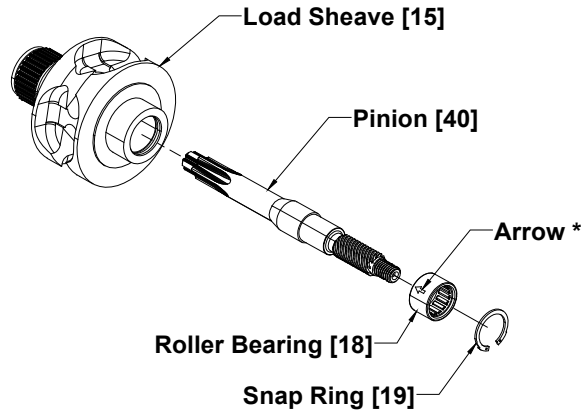


Figure 6-1 Load Sheave/Pinion Assembly

- 2)** Grease the balls of the ball bearing [16]. Orient side plate A [12] with brake cover side down and insert the ball bearing [16] into side plate A with the bearings retaining ring side up.
- 3)** Insert the load sheave [15] with a part of spline side (pinion gear side) up into the ball bearing [16]. The stripper [21] must be inserted as well. See Figure 6-2.

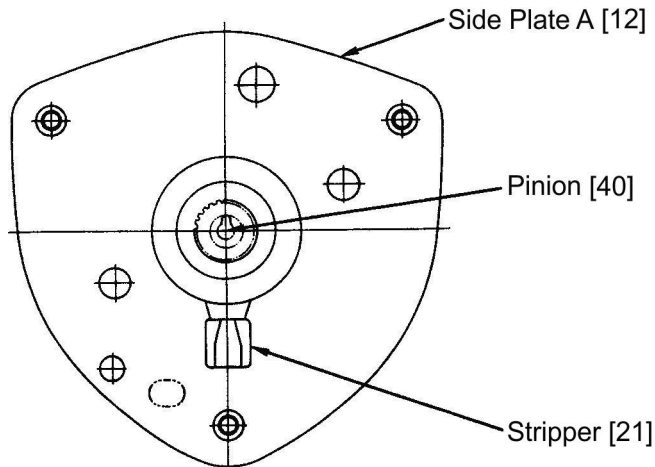


Figure 6-2 Side Plate / Load Sheave Assembly

- 4)** For 8 ton capacity and below:
Put the guide rollers [20] and the anchorage (stopper) [22] in the side plate A [12].
For 10 ton and larger capacities:
Put the guide rollers [20] and the cross guide [55] in the side plate A [12].
***NOTE:** Put the cross guide so that the longer retaining arm fits into side plate A.
- 5)** Grease the balls of the ball bearing [17]. Insert it with the snap ring side down to the shaft of the load sheave [15]. See figure 6-3.
***NOTE:** Make sure the snap ring side of the ball bearing is oriented toward the load sheave.

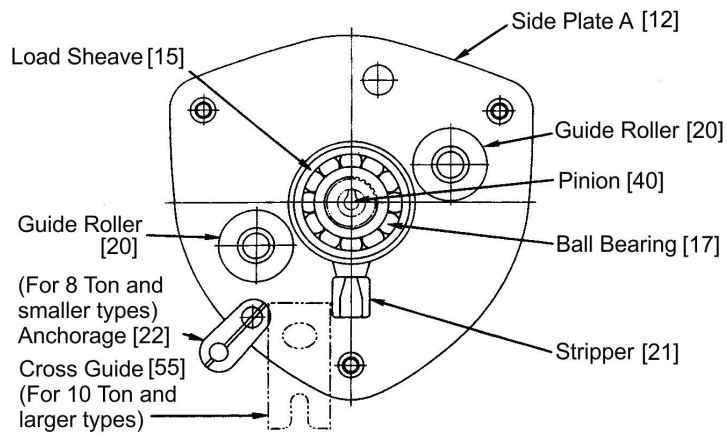


Figure 6-3 Side Plate Assembly

- 6) Join the side plate B [14] to the side plate A [12].

***NOTE:** In case it is difficult to join the two, tap it with a rubber mallet. Be careful not to let the stripper, guide roller or anchorage (cross guide 10T and larger) fall down.

- 7) Mesh the load gear [25] with the splines of the load sheave [15] and fix it with a snap ring [26].

⚠WARNING : Always make sure the snap ring is completely seated at the bottom of the groove.

- 8) Grease the two gear #2 [27] (one for 1/2T), the load gear [25], and the gear of the pinion [40]. Place them in side plate B [14] in the correct gear plane. Letters "O" and "V" on the gears must face each other as shown in figure 6-4 below. Do not forget to apply grease to the boss on both sides of gear #2.

***NOTE:** It is not necessary to adjust the letters in the case of the 1/2T model, for it has only one gear #2.

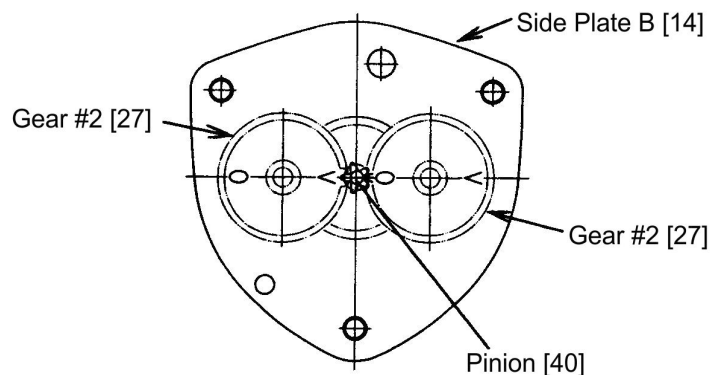


Figure 6-4 Gear Train Assembly

- 9) Grease the balls of the ball bearing [28] and insert it with the snap ring down into the end of the pinion [40] shaft.

- 10) Join the gear case [29] to the side plate A [12] and fix them with the three spring washers [31] and nuts [30].

- 11)** Place the top hook [1] between side plates A [12] and B [14]. Then insert top pin [4] and fix it with the split pin [5]. For Bullard®, SmartLok™/Shur-loc®, or Inspection type hooks, refer to Table 6-3 for yoke nut torque specifications.

⚠WARNING : Always bend the split pin securely after inserting it into the top pin.

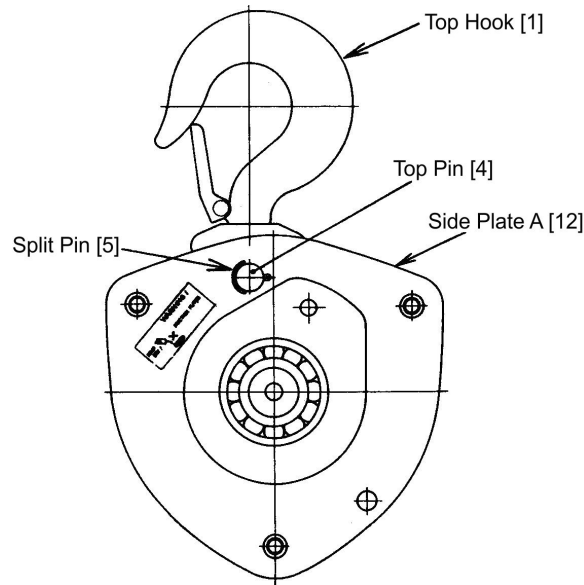


Figure 6-5 Gear Train Assembly

- 12)** Place the hand wheel [41] side upward.
- 13)** Reeve the load chain [48] turning the pinion clockwise through the space between the left (bottom hook side) guide roller [20] and the load sheave [15]. See figure 6-6.

⚠WARNING : Put the welded part of the vertical chain link outward and reeve it through the load sheave. Pull it out between the right guide roller (no load side) and the load sheave.

For 10 ton capacities and above, pass the no load end of the chain through the cross guide [55].

***NOTE:** It is recommended for this process to position the unit so that the side plate A [12] faces left and the side plate B [14] faces right.

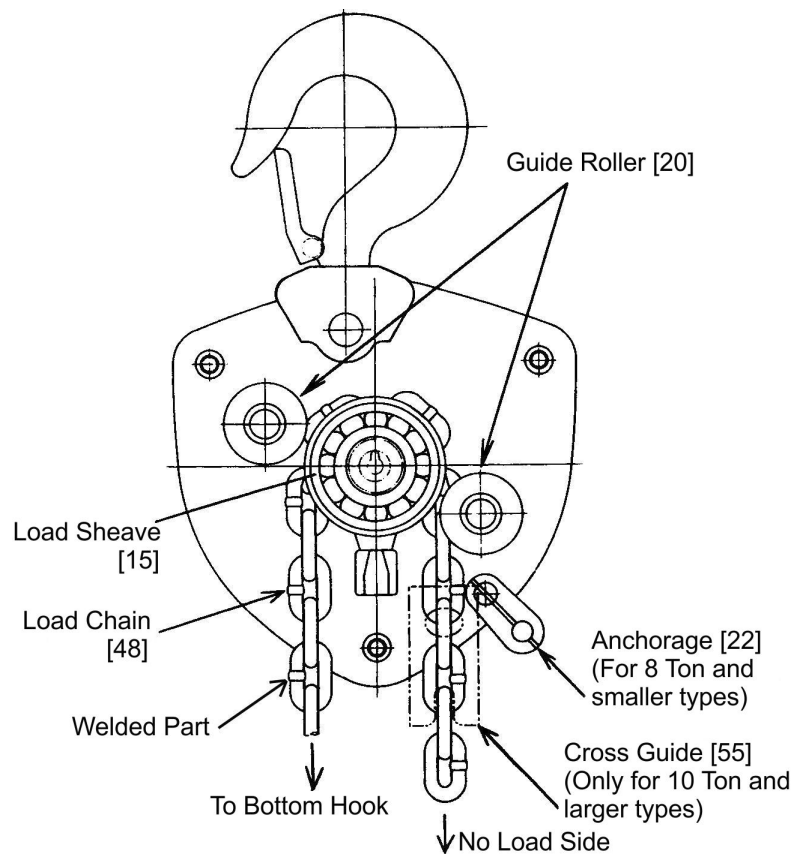


Figure 6-6 Reeving Assembly

14) For 8 ton capacity and below:

Pull the end of the load chain [48] out between the right guide roller [20] and the load sheave [15] (no load side) and insert it to the anchorage (stopper) [22]. Insert the stopper pin [23] and fix it with a split pin [24].

⚠ WARNING : Make sure the load chain is not twisted and the split pin in the stopper pin is bent securely.

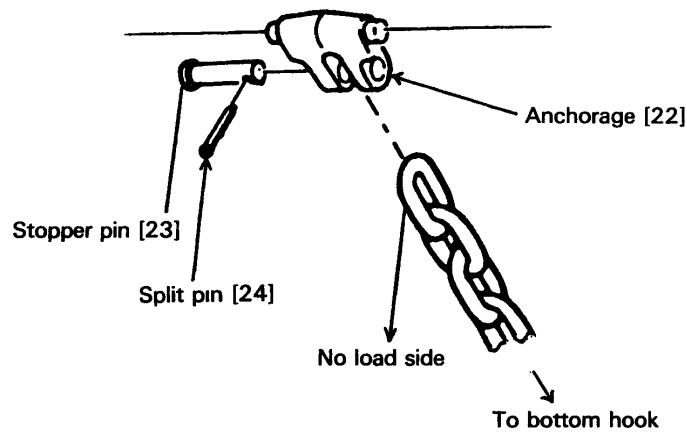


Figure 6-7 8 Ton & Below Anchorage Assembly

For 10 ton capacity and above:

Connect the no load end of the load chain [48] to the end pin [53] which is to be inserted from gear case [29] side. Use a split pin [54] to secure the end pin. Assemble stoppers [114] to the ninth link from the no load end of the load chain by socket bolts and spring washers.

***NOTE:** Threaded hole of one stopper shall face to non-threaded hole of the other stopper. Socket bolt shall be inserted from the non-threaded side.

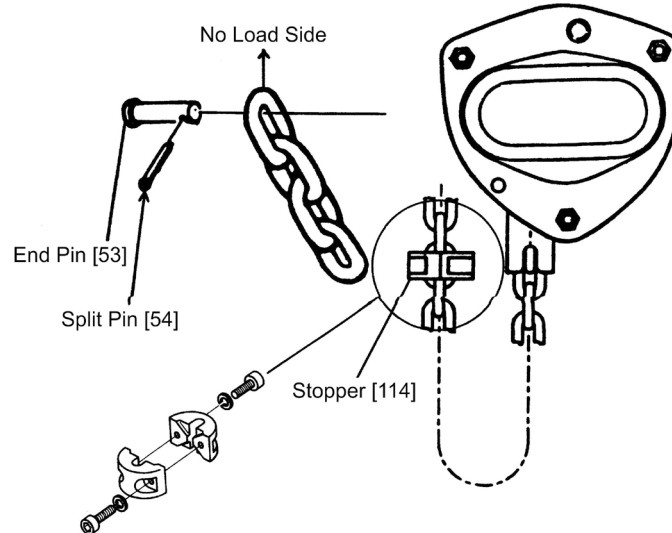


Figure 6-8 10 Ton & Above Anchorage Assembly

- 15)** Apply machine oil to the pawl pin (in side plate A [12]) and join the pawl spring assembly [32] and the pawl [33] respectively to it. Fix them with a snap ring [34]. See figure 6-9.

⚠WARNING : Make sure the pawl spring is touching the pawl and the snap ring is completely seated at the bottom of the groove.

- 16)** Attach the friction disc [35] to the pinion [40] shaft (while turning the pawl [33] counterclockwise).

- 17)** Wipe out any dirt on the friction disc [35], friction plates [36] and both sides of the ratchet disc [37] and check if the oil of the bushing [38] (bushing with oil in it) is adequate. Then place the friction plate, bushing, ratchet disc and friction plate respectively on the friction disc. (Make sure that the ratchet disc and the pawl mesh properly). See figure 6-9.

⚠WARNING : Since the brake is a “dry system”, **NEVER** apply oil. Wipe out thoroughly any oil and dirt on the brake. The gear of the ratchet disc should point at the pawl. Otherwise, the hand wheel cannot be assembled later. In case the bushing does not have oil inside, soak it in turbine oil for a day. Install it without wiping the oil.

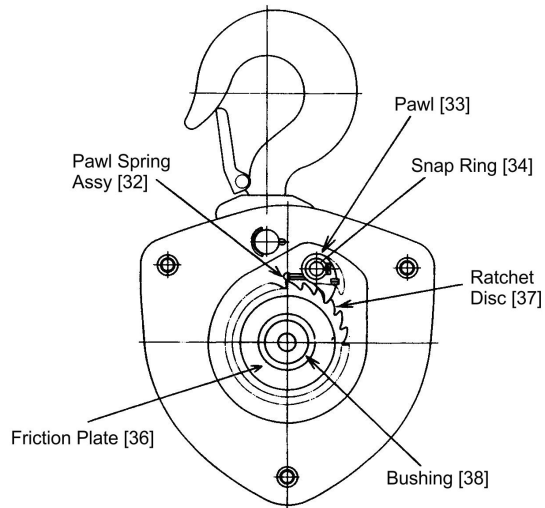


Figure 6-9 Pawl & Brake Assembly

- 18)** Wipe out any dirt on the brake surface of the hand wheel [41] and apply machine oil to the threaded part of it. Screw it on the pinion [40] shaft all the way down.
- 19)** With overload limiter - Install the washer [43] and the castle nut [42] onto the pinion shaft to finger tightness (left-handed threads). Line up slot in castle nut with hole in the pinion shaft. Insert the split pin and fix it.
- 19a)** Without OLL (optional)- Place the wheel stopper [42] on the head of the pinion [40], insert the Wheel stopper pin [43] and fix it with a split pin [44].

⚠ WARNING : Never forget to bend the split pin securely after inserting through the castle nut or wheel stopper pin.

- 20)** Put the hand chain [49] around the hand wheel [41]. See figure 6-10.

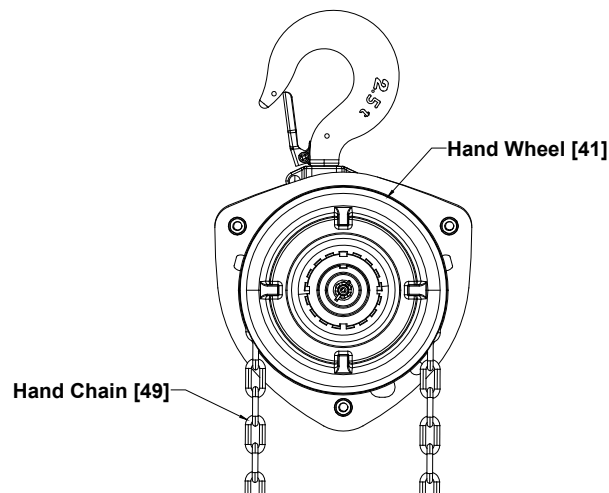


Figure 6-10 Hand Wheel Assembly

- 21) Assemble the wheel cover [45] to the side plate A [12] and fix them with the spring washer [47] and the nut [46].
- 22) Insert the other end of the load chain [48] to the bottom hook [6] and fix them with the chain pin [8], slotted nut [9] and split pin [10]. See figure 6-11. For Bullard®, SmartLok™/Shur-loc®, or Inspection type hooks, refer to Table 6-3 for yoke nut torque specifications.

⚠ WARNING : Always bend the split pin securely.

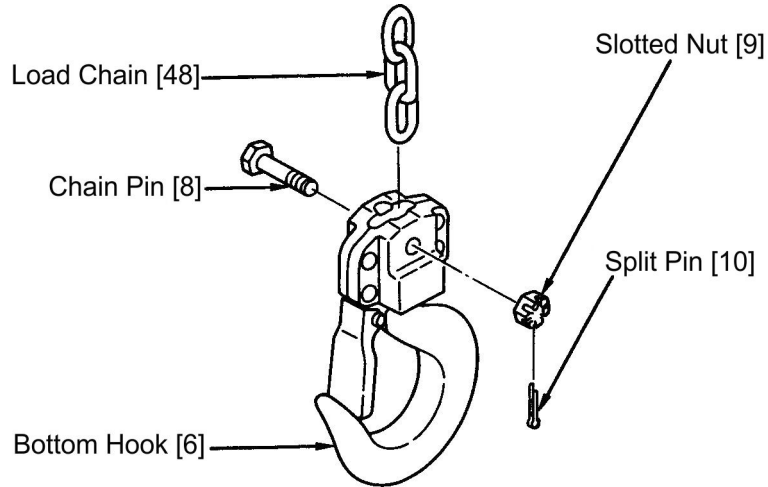


Figure 6-11 Bottom Hook Assembly

Cap. (Tons)	Product Code	Bottom Bullard®	Top Bullard®	Bottom Shur-loc®	Top Shur-loc®	Bottom Inspection	Top Inspection	Bottom SmartLok™	Top SmartLok™
1/2	CB005	55	55	55	55	55	55		
1	CB010	55	55	55	55	55	55		
1½	CB015	85	85	85	85	85	85		
2	CB020	85	85	85	85	85	85		
2½	CB025	85	85	85	85	85	85		
3	CB030	398		398				398	
5	CB050	398		398				398	

6.5 Storage

6.5.1 **⚠ WARNING** : **IMPROPER** chain hoist use could result in death or serious injury. To avoid these hazards:

- **ALWAYS** store the hoist in a no load condition.
- **ALWAYS** wipe off all dirt and water.
- **ALWAYS** oil the chain, hook pins and hook latches.
- **ALWAYS** hang in a dry place.
- **ALWAYS** check the hoist for abnormalities (according to the regular inspection procedures) when using the hoist after a period of non-use (Refer to section 5.5).

6.6 Outdoor Installation

- 6.6.1 The hoist/trolley should be covered when not in use.
- 6.6.2 The hoist/trolley **MUST BE** inspected and maintained according to the 'Severe Service' Inspection Classification. **Refer to Section 5.0.**
- 6.6.3 When using a steel chain container, remove the plug to allow for the drainage of pooling water. Canvas chain containers are not recommended for outdoor use.
- 6.6.4 Possibility of corrosion on components of the hoist increases for installations where salt air and high humidity are present. For installations where temperature variations introduce condensation/corrosion into the hoist, more frequent lubrication may be required.
- 6.6.5 Refer to Section 2.1.2 for allowable environmental conditions.

7.0 Troubleshooting

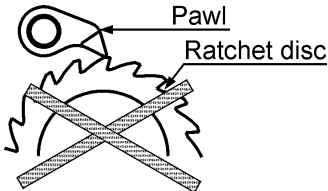
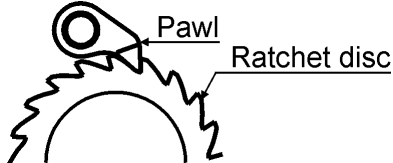
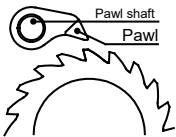
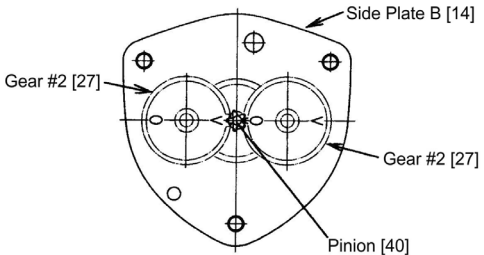
⚠ WARNING

Read and comply with instructions in this manual and use the hoist properly.
 Checking the sounds from the hoist in operation is a critical inspection. Note hoist sounds during operation.
 If a defect is found in the hoist, stop using it immediately and check the cause of the defect.
 Only Trained and competent personnel should inspect and repair the hoist.

Table 7-1 Troubleshooting Guide

Note on proper operation:

- When lifting, the hoist must make clicking sounds when moving the hand wheel.
- When lowering, the hoist should not make clicking sounds when moving the hand wheel.

Symptom	Cause	Remedy
Hoist will not lift – Slight clicking	Improper assembly of ratchet disc, disc installed backwards, and making incorrect contact with the pawl. 	Reassemble the pawl and ratchet disc properly. Ensure that clicking sounds are heard before reuse. 
Hoist will not lift – Not Clicking	Pawl not engaging ratchet disc: ■ Dirt or corrosion between pawl and pawl shaft.	Clean and lubricate pawl and pawl shaft. 
	Faulty pawl spring	Replace pawl spring
	Loose selector pawl spring	Perform hoist maintenance.
Hoist will not lift – Hand wheel will not operate	Gear #2 improperly timed	Reassemble gears properly and ensure smooth operation before reuse. ⚠ CAUTION Ensure the '0' & "V" marks of gear #2 are aligned properly, as shown. 

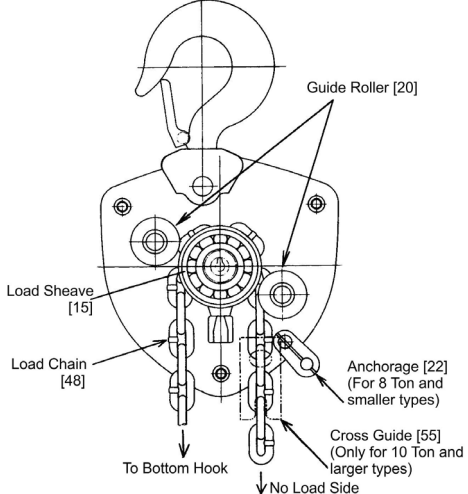
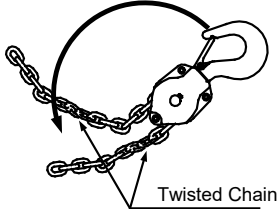
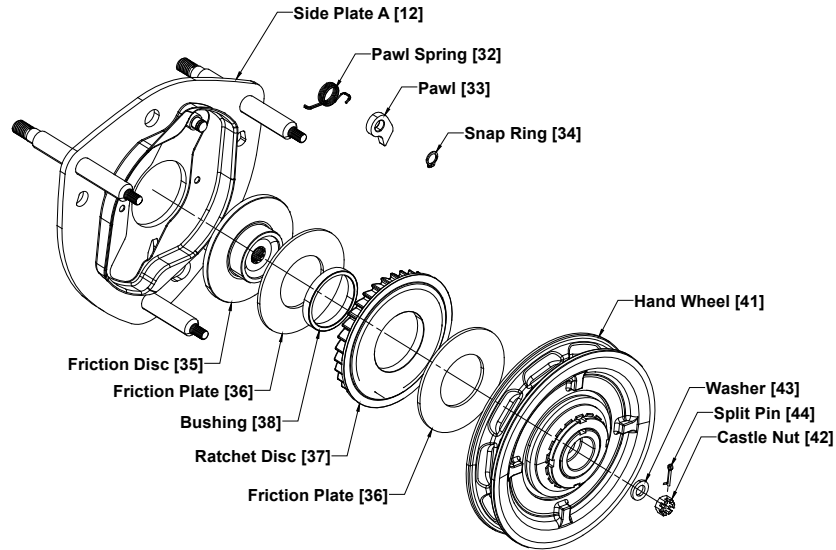
Symptom	Cause	Remedy
<p>Hoist will lift intermittently – Slight or irregular clicking</p>	<p>Poor pawl movement caused by faulty pawl spring. The spring is loose or damaged.</p> <p>Mis-assembly of pawl spring</p>	<p>Perform maintenance and/or repair.</p> <p>Reassemble it properly and ensure to check click sound of the pawl before reuse.</p>
<p>During operation, hoist idles or load drifts</p>	<p>Poor contact of load sheave and load chain caused by improper chain-reeving.</p>	<p>Reassemble properly and ensure proper lifting before reuse.</p> 
<p>Hoist will not lift all the way (multiple fall hoists)</p>	<p>Capsized hook</p>	<p>Reset the capsized hook.</p>  <p>Capsized Hook and Chain Double Fall Models</p>
<p>Hoist does not lift load smoothly.</p>	<p>Improper assembly of gear OR bearing broken.</p>	<p>Disassemble and reassemble gear train and/or replace bearing.</p>

Table 7-1 Troubleshooting Guide

⚠ CAUTION Improper braking may cause improper load lowering. The hoist utilizes dry friction discs; do not apply oil to friction surfaces.



Symptom	Cause	Remedy
Load will not go down	Over tightened brake The hoist left under load for a long period Shock loaded during operation	Pull down hard (possibly with 2 people) on the hand chain to loosen brake.
	Brake rusted tight	Replace the rusty components and perform hoist maintenance.
Load drifts or slips when lowering	A foreign object between friction surfaces.	Remove the object and clean the surfaces. Replace if the friction surface is scarred.
	Brake slip caused by significant rust	Replace the rusty component and perform hoist maintenance.
	Mis-assembly of friction plates, i.e. friction plates missing or at one side as shown.	Reassemble properly as shown and ensure hoist functions properly before reuse.
	Cracked friction plate caused by overload	Replace the friction plate and use the hoist properly within rated capacity.
Friction plate wear caused by very frequent and long term use.	Perform hoist maintenance.	

8.0 Warranty

All products sold by Harrington Hoists, Inc. are warranted to be free from defects in material and workmanship from date of shipment by Harrington for the following periods:

1 year – Electric and Air Powered Hoists (excluding (N)ER2 Enhanced Features Models and EQ/SEQ Models), Powered Trolleys, Powered Tiger Track Jibs and Gantries, Crane Components, Below the Hook Devices, Spare / Replacement Parts

2 years – Manual Hoists & Trolleys, Beam Clamps

3 years – (N)ER2 Enhanced Features Hoists, EQ/SEQ Hoists, and RY Hoists

5 years – Manual Tiger Track Jibs and Gantries, TNER, EQ/SEQ, and RY Hoist Motor Brakes

10 years – (N)ER2 “The Guardian” Smart Brake

The product must be used in accordance with manufacturer’s recommendations and must not have been subject to abuse, lack of maintenance, misuse, negligence, or unauthorized repairs or alterations.

Should any defect in material or workmanship occur during the above time period in any product, as determined by Harrington Hoist’s inspection of the product, Harrington Hoists, Inc. agrees, at its discretion, either to replace (not including installation) or repair the part or product free of charge and deliver said item F.O.B. Harrington Hoists, Inc. place of business to customer.

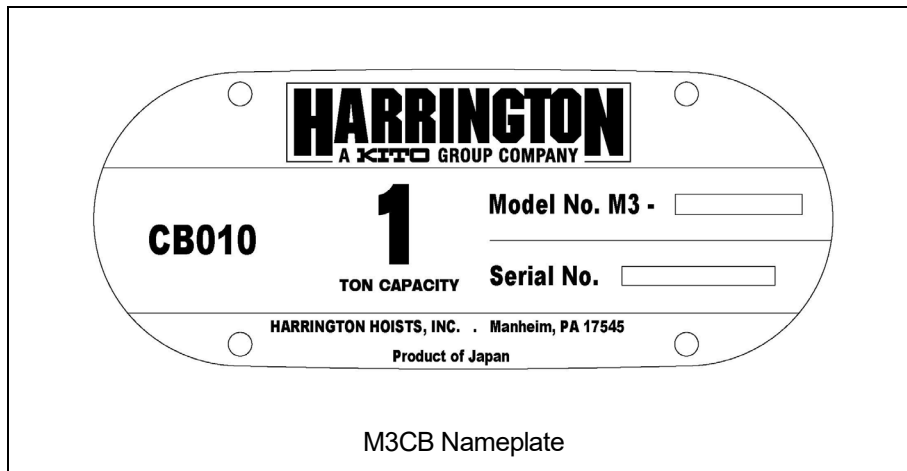
Customer must obtain a Return Goods Authorization as directed by Harrington or Harrington’s published repair center prior to shipping product for warranty evaluation. An explanation of the complaint must accompany the product. Product must be returned freight prepaid. Upon repair, the product will be covered for the remainder of the original warranty period. Replacement parts installed after the original warranty period will only be eligible for replacement (not including installation) for a period of one year from the installation date. If it is determined there is no defect, or that the defect resulted from causes not within the scope of Harrington’s warranty, the customer will be responsible for the costs of returning the product.

Harrington Hoists, Inc. disclaims any and all other warranties of any kind expressed or implied as to the product’s merchantability or fitness for a particular application. Harrington will not be liable for death, injuries to persons or property or for incidental, contingent, special or consequential damages, loss or expense arising in connection with the use or inability whatever, regardless of whether damage, loss or expense results from any act or failure to act by Harrington, whether negligent or willful, or from any other reason.

9.0 Parts List

When ordering Parts, please provide the Hoist model number, lot number, and serial number located on the Hoist nameplate (see Figure below).

Reminder: Per Sections 1.1 and 3.4.4 to aid in ordering parts and product support, record the hoist Code, Lot and Serial Number in the space provided on the cover of this manual.



The parts list is arranged into the following sections:

Section	Page
9.1 1/2 to 20 Ton Body Parts.....	42
9.2 Optional without Overload Limiter and SHB units	45
9.3 3 & 5 Ton Suspension and Chaining Parts.....	46
9.4 8 & 10 Ton Suspension and Chaining Parts.....	48
9.5 15 & 20 Ton Suspension and Chaining Parts.....	50
9.6 Optional Hooks.....	54
9.7 Optional Canvas Chain Containers.....	56

9.1 1/2 to 20 Ton Parts

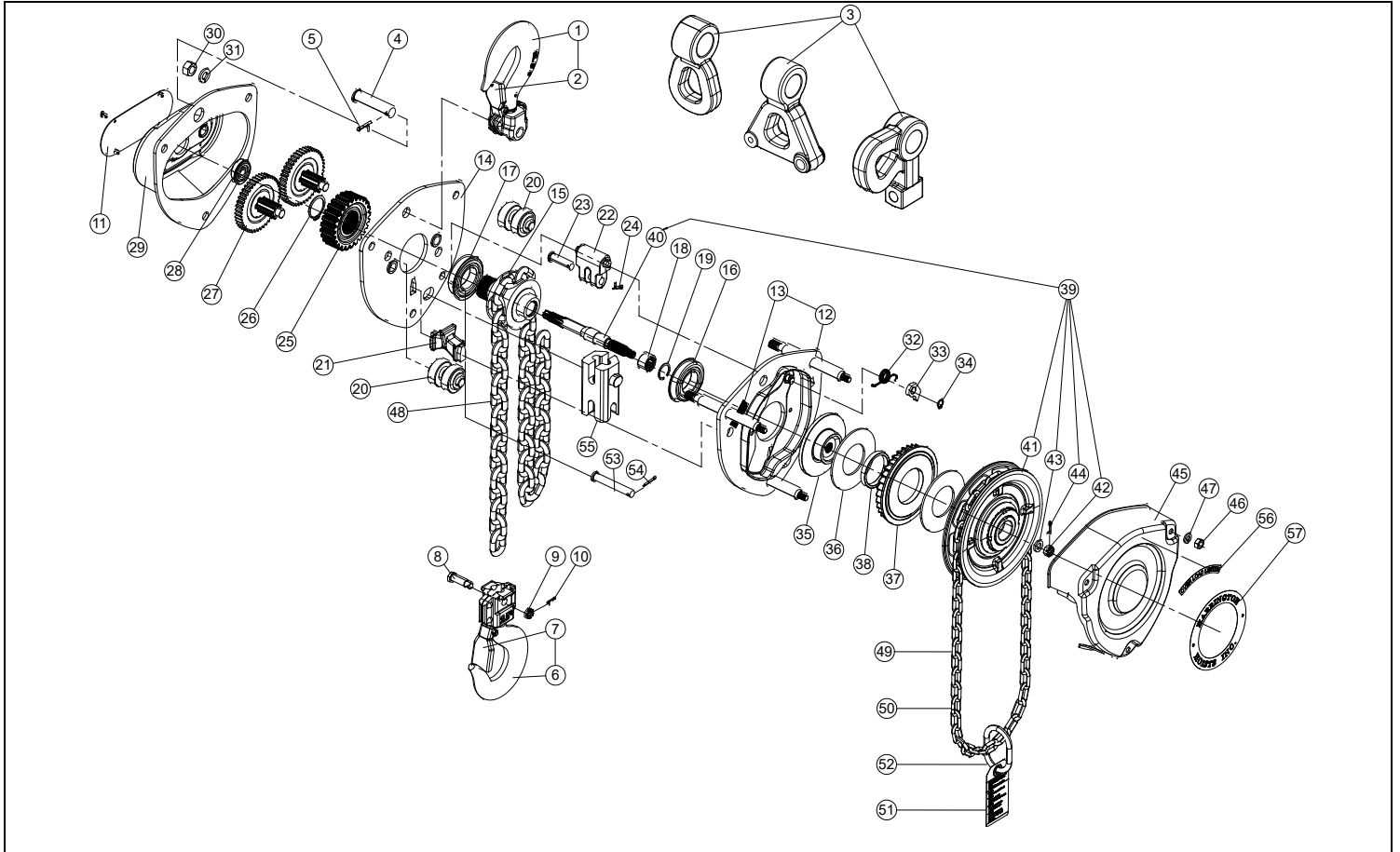


Figure 9-1 – 1/2 to 20 Ton Body Parts

9.1 1/2 to 20 Ton Body Parts

Fig. No.	Part Name	Qty per Hoist	Capacity (T)				
			1/2	1	1½	2	2½
1	Top Hook Set	1	CF001005	CF001010	CF001015	M3001A020	M3001A025
2	Latch Assembly	1	CF071005	CF071010	CF071015	CF071020	CF071030
3	Suspender C	1	T7GC004005	T7GC004010	T7GC004020		T7GC004025
	Suspender H	1	T6G019005	T6G019010	T6G019020		T6G019030
4	Top Pin	1	M3163005	M3163010	M3163015	M3163020	M3163025
5	Split Pin	1	9009423			9009424	
6	Bottom Hook Set	1	M3021A005	M3021A010	M3021A015	M3021A020	M3021A025
7	Latch Assembly	1	CF071005	CF071010	CF071015	CF071020	CF071030
8	Chain Pin	1	M3041005	M3041010	M3041015	M3041020	M3041025
9	Slotted Nut	1	M3049005	M2049010		M2049020	
10	Split Pin	1	9009402	9009411		9009412	
11	Nameplate B w/ Rivets	1	M3800005	M3800010	M3800015	M3800020	M3800025
	(M3B Model)						

Fig. No.	Part Name	Qty per Hoist	Capacity (T)					
			1/2	1	1½ & 3	2	2½ - 5 - 8	10 - 15 - 20
12	Side Plate A Ass'y	1	M3101005	M3101010	M3101015	M3101020	M3101025	
	(M3B Model)							M3B101025
13	Nameplate F	1	C3BA0059806					
14	Side Plate B Ass'y	1	M3102005	M3102010	M3102015	M3102020	M3102025	
	(M3B Model)							M3B102025
15	Load Sheave	1	M3116005	M3116010	M3116015	M3116020	M3116025	
16	Ball Bearing	1	M3140005			M3140020		
17	Ball Bearing	1	M3145005		M3140005		M3140020	
18	Roller Bearing	1	M3130005			M3130020		
19	Snap Ring	1	M3118005			M3118020		
20	Guide Roller	2	M3161005	M3161010	M3161015	M3161020	M3161025	
21	Stripper	1	M3162005	M3162010	M3162015	M3162020	M3162025	
22	Anchorage	1	M3176005	M3176010	M3176015	M3176020	M3176025	
23	Stopper Pin	1	M3177005	M3177010	M3177015	M3177020	M3177025	
24	Split Pin	1	9009412		9009415-5			
25	Load Gear	1	M3114005	M3114010	M3114015	M3114020	M3114025	
26	Snap Ring	1	9047123		9047128		9047132	
27	Gear No. 2 Ass'y	()	M3112005 (1)	M3112010 (2)	M3112015 (2)	M3112020 (2)	M3112025 (2)	
	(M3B Model)	2					M3B112025	
28	Ball Bearing	1	M3135005			M3135020		
29	Gear Case Ass'y	1	M3103005	M3103010	M3103015	M3103020	M3103025	
30	Nut	3	9093424			9093427	9093433	
31	Spring Washer	3	9012711			9012712	9012713	
32	Pawl Springs Ass'y	1	C3BA0055179					
33	Pawl	1	M3155005					
34	Snap Ring	1	9047110					

20 Ton capacity requires Qty per Hoist multiplied by 2 (except load chain)

9.1 1/2 to 20 Ton Body Parts

Fig. No.	Part Name	Qty per Hoist	Capacity (T)					
			1/2	1	1½ & 3	2	2½ - 5 - 8	10 - 15 - 20
35	Friction Disc	1	M3153005			M3153020		
	(M3B Model)							M3B153025
36	Friction Plate	2	M3151005			M3151020		
	(M3B Model)							M3B151025
37	Ratchet Disc	1	M3152005			M3152020		
	(M3B Model)							M3B152025
38	Bushing	1	M3154005			M3154020		
	(M3B Model)							M3B154025
39	OLL Assembly		M3CB005OD	M3CB01OD	M3CB015OD	M3CB020OD	M3CB025OD	
	(M3B Model)							M3B025OD
40	OLL Pinion	1	C3YA111005	C3YA111010	C3YA111015	C3YA111020	¹ C3YA111025	
	(M3B Model)							C3BYA111025
41	OLL Hand Wheel	1	M3CB005OD	M3CB010OD	M3CB015OD	M3CB020OD	¹ M3CB025OD	
	(M3B Model)							M3B025OD
42	Slotted Nut (Left-handed thread)	1	C3YA209005			C3YA209020		
43	Washer	1	C3YA208005			C3YA208020		
44	Split Pin	1	9009412			9009414-5		
45	Wheel Cover Ass'y	1	M3171005		M3171015	M3171020	M3171025	
46	Nut	3	9093424					
47	Spring Washer	3	9012711					
48	Load Chain	Black	LCCF005	LCCF010	LCCF015	LCC3020	LCC3025	
		Nickel Plated	LCCF005NP-DIN	LCCF010NP-DIN	LCCF015NP-DIN	LCC3020NP-DIN	LCC3025NP-DIN	
49	Hand Chain	Plain	HCCF005A					
		Zinc	HCCF005ZNA					
		SS	K7RA0500000					
50	Hand Chain Master link	Plain	HCCF005MLA					
		Zinc	HCCF005ZNMLA					
		NP	C1FA0159843N					
51	Warning Tag (WTAG9)	1	80146					
52	Chain Stopper Link	1	L5BA0329045					
53	End Pin	1						M3B164100
54	Split Pin	1						9009415-5
55	Cross Guide	1						M3B176100
56	Slip Clutch Label	1	C3YU0059802			C3YU0209802		
57	Harrington Label	1	M3700005		M3700015	M3700020	M3700025	

¹Part Number does not apply to 8 Ton capacity.

20 Ton capacity requires Qty per Hoist multiplied by 2 (except load chain)

9.2 Optional without Overload Limiter and SHB units

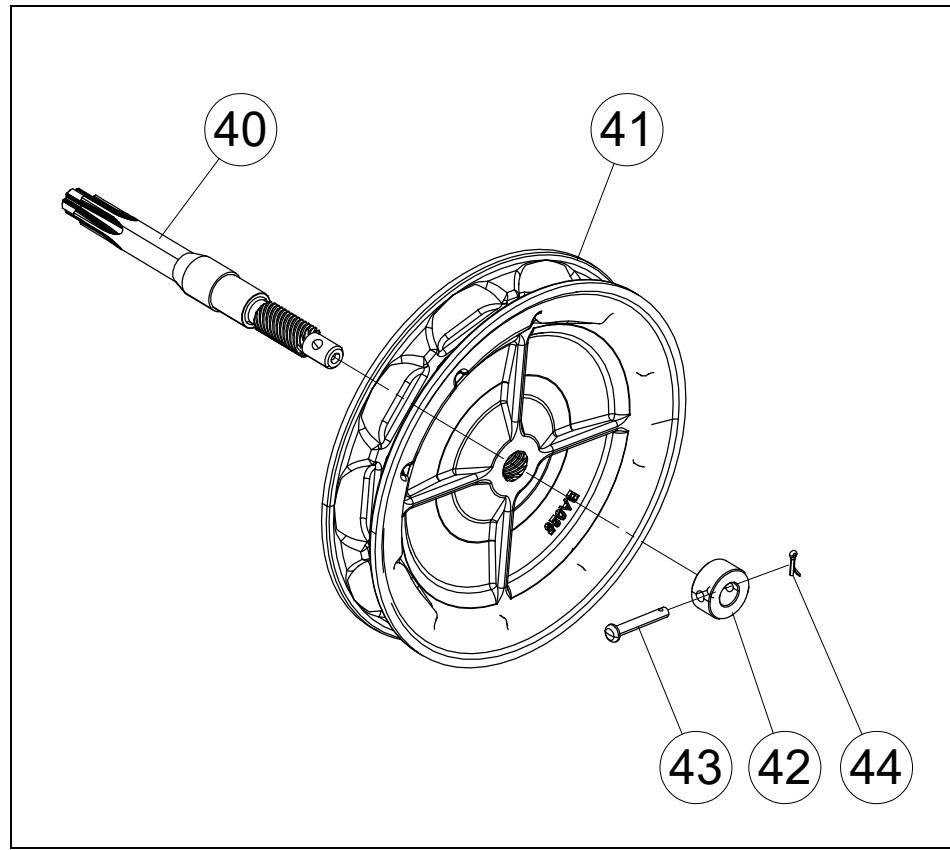
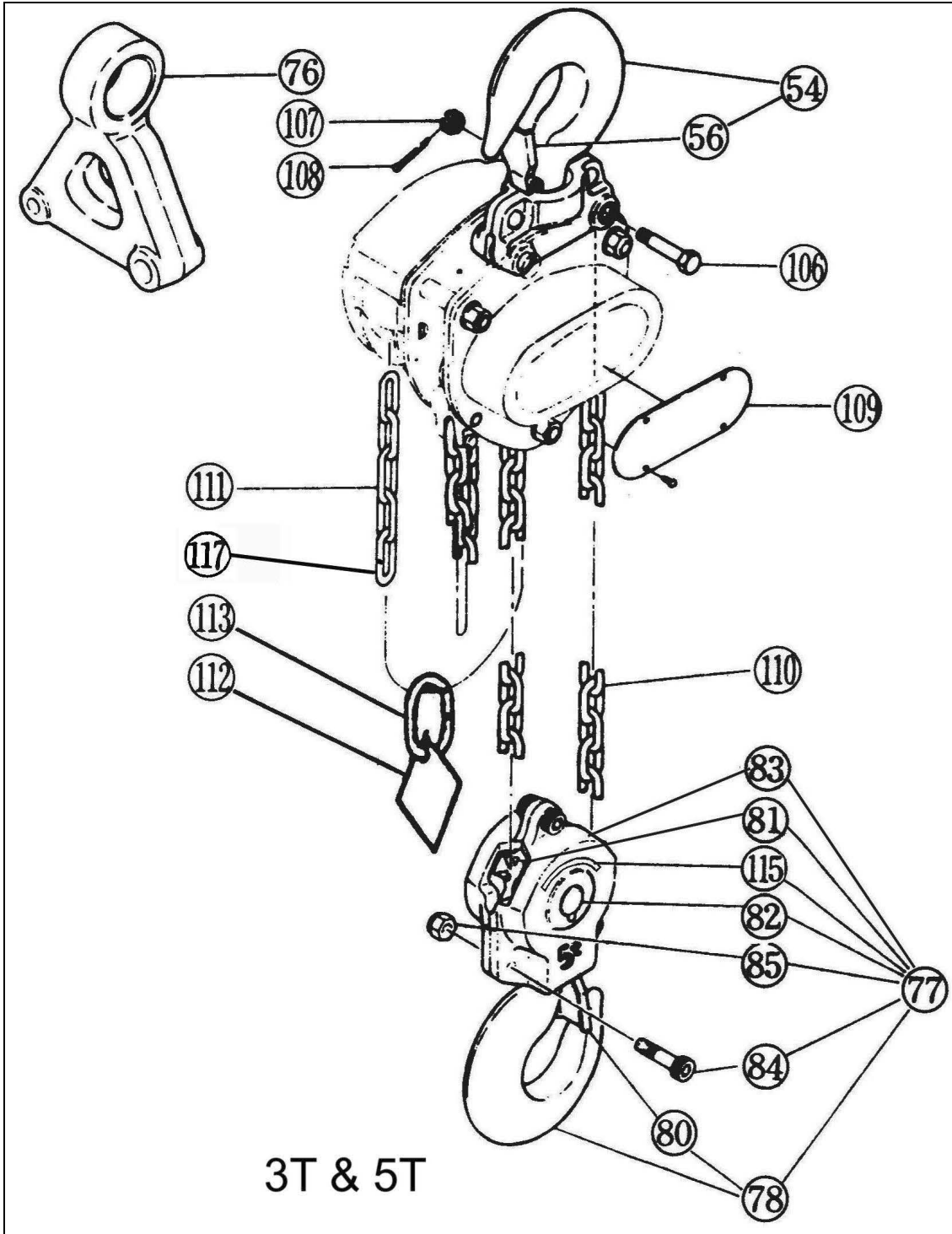


Fig. No.	Part Name		Qty	Capacity (T)					
				1/2	1	1 1/2 & 3	2	2 1/2 & 5	8-10-15-20*
40	Pinion	M3	1	M3111005	M3111010	M3111015	M3111020	M3111025	
		M3B		M3B111025					
41	Hand Wheel	M3	1	M3115005		M3115015	M3115020	M3115025	
		M3B		M3B115025					
42	Wheel Stopper		1	CF159005			CF159010		
43	Wheel Stopper Pin		1	M2167005					
44	Split Pin		1	9009410					

*20 Ton capacity requires Qty per Hoist multiplied by 2

9.3 3 & 5 Ton Suspension and Chaining Parts

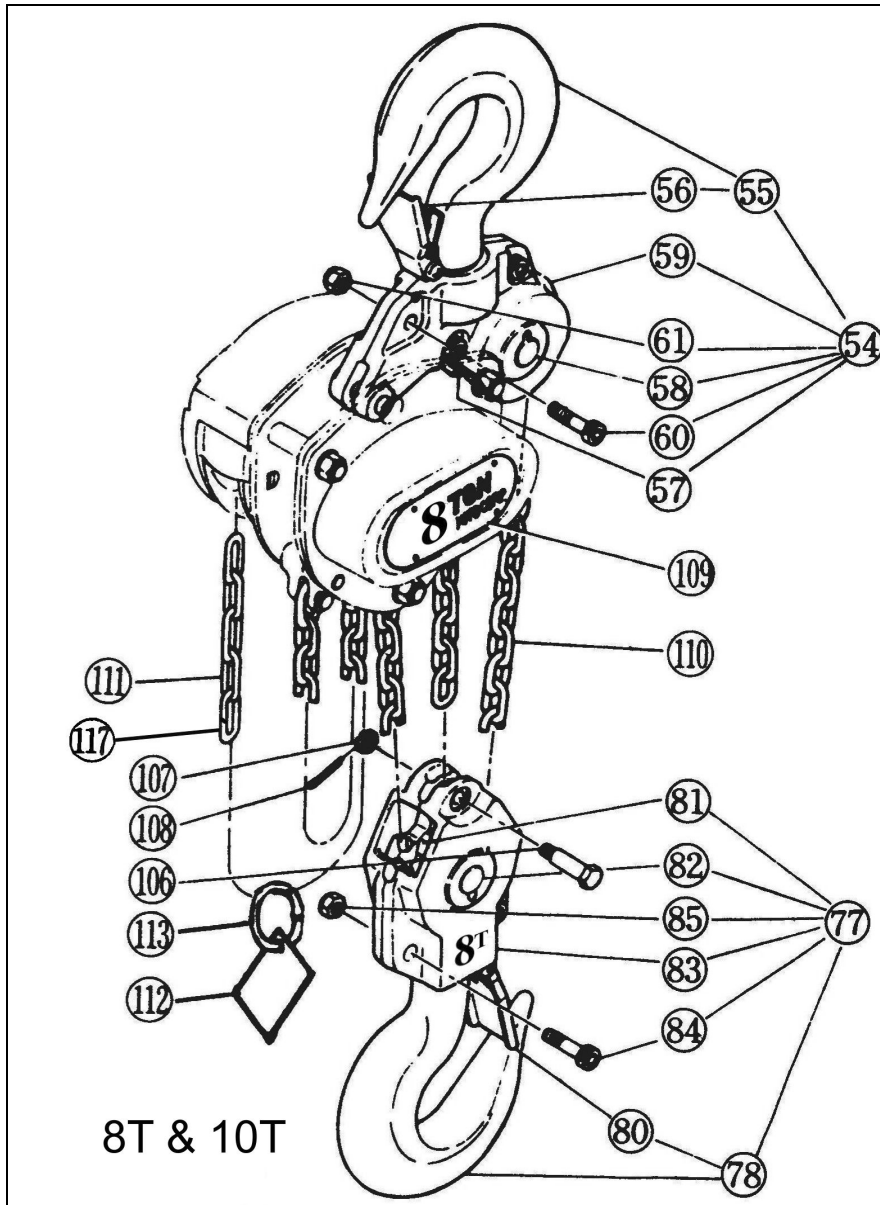


9.3 3 & 5 Ton Suspension and Chaining Parts

Fig. No.	Part Name		Qty per Hoist	Capacity (T)	
				3	5
54	Top Hook Set		1	M3001A030	M3001A050
56	Latch Assembly		1	CF071030	M3072050
76	Suspender C		1	T7GC004030	*M3004050
	Suspender H		1	T6G019030	
77	Bottom Hook Set		1	M3021A030	M3021A050
78	Bottom Hook Assembly		1	M3021030	M3021050
80	Latch Assembly		1	CF071030	M3072050
81	Idle Sheave Assembly		1	CF051030	M3051050
82	Shaft Assembly		1	CF053030	M3053050
83	Bottom Yoke Assembly		1	M3031030	M3031050
84	Socket Bolt		()	9091296 (2)	9091296 (3)
85	Lever Nut		()	C2BA200-90741 (2)	C2BA200-90741 (3)
115	Label (Do not capsize)		1	80173	
106	Chain Pin		1	M3041030	M3041075
107	Slotted Nut		1	M2049010	M2049020
108	Split Pin		1	9009411	9009412
109	Nameplate B w/ Rivets		1	M3800030	M3800050
	(M3B Model)				M3B800050
110	Load Chain	Black	ft	LCCF015	LCC3025
		Nickel Plated		LCCF015NP-DIN	LCC3025NP-DIN
111	Hand Chain	Plain	ft	HCCF005A	
		Zinc		HCCF005ZNA	
		Stainless Steel		K7RA0500000	
117	Hand Chain Master Link	Plain	1	HCCF005MLA	
		Zinc		HCCF005ZNMLA	
		Nickel Plated		C1FA0159843N	
112	Warning Tag (WTAG9)		1	80146	
113	Chain Stopper Link		1	L5BA0329045	

*For use with PTS2050 or GTS2050 trolleys only

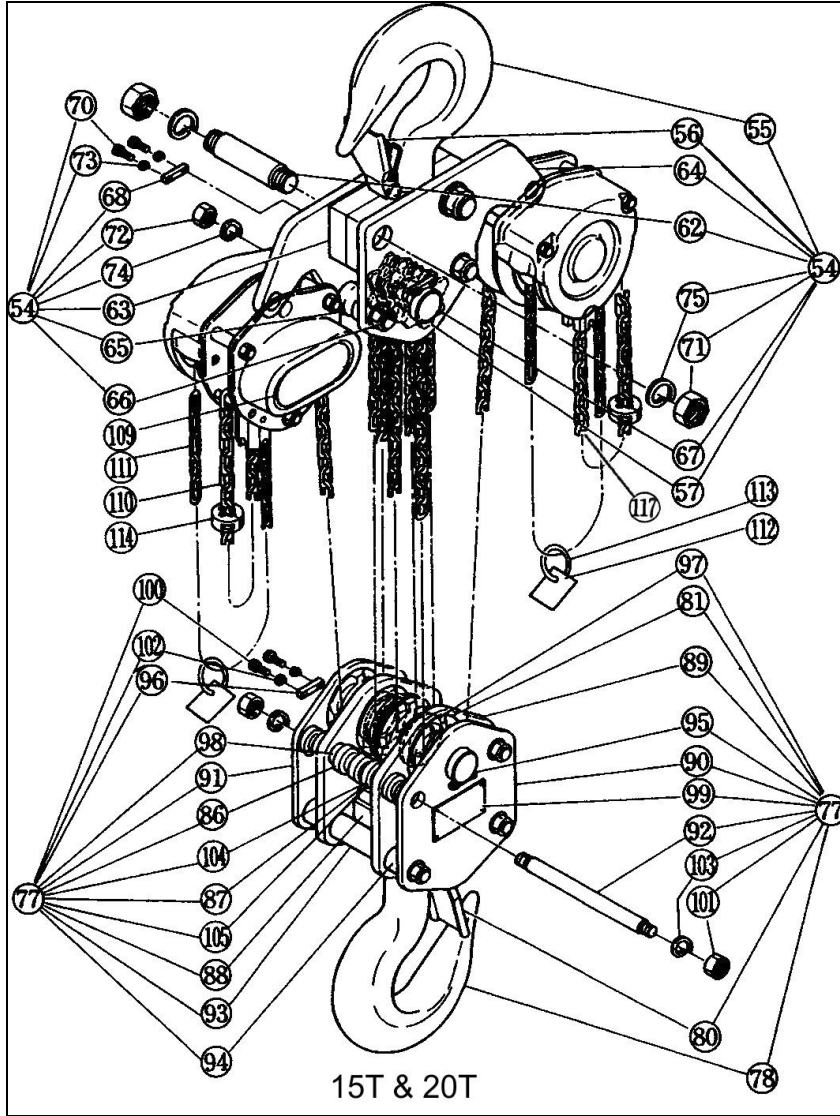
9.4 8 & 10 Ton Suspension and Chaining Parts



9.4 8 & 10 Ton Suspension and Chaining Parts

Fig. No.	Part Name		Qty per Hoist	Capacity (T)	
				8	10
54	Top Hook Set		1	M3001A075	M3001A100
55	Top Hook Assembly		1	L42001090	
	56	Latch Assembly	1	L41071090	
57	Idle Sheave Assembly		1	M3051050	
58	Shaft Assembly		1	M3053050	
59A	Top Yoke A		1	M3011075	M3011100
59B	Top Yoke B		1	M3012075	M3012100
60	Socket Bolt (M12 x 1.75 x 40)		()	90912116 (3)	90912116 (1)
	Socket Bolt (M16 x 2.0 x 60)		2		M3086100
61	Lever Nut (M12 x 1.75)		()	L4082090 (3)	L4082090 (1)
	Lock Nut (M16 x 2.0)		2		9098516
77	Bottom Hook Set		1	M3021A075	M3021A100
78	Bottom Hook Assembly		1	L42001090	
	80	Latch Assembly	1	L41071090	
81	Idle Sheave Assembly		()	M3051050 (1)	M31052100 (2)
82	Bottom Shaft Assembly		1	M3053050	M3054100
83	Bottom Yoke Assembly		1	M3031075	M3031100
84	Socket Bolt		2	90912116	M3088100
85	Lever Nut		2	L4082090	
	Lock Nut				9098516
106	Chain Pin		1	M3041075	
107	Slotted Nut		1	M2049020	
108	Split Pin		1	9009412	
109	Nameplate B w/ Rivets		1	80550	M3B800100
110	Load Chain	Black	ft	LCC3025	
		Nickel Plated		LCC3025NP-DIN	
111	Hand Chain	Plain	ft	HCCF005A	
		Zinc		HCCF005ZNA	
		Stainless Steel		K7RA0500000	
117	Hand Chain Master link	Plain	1	HCCF005MLA	
		Zinc		HCCF005ZNMLA	
		Nickel Plated		C1FA0159843N	
112	Warning Tag (WTAG9)		1	80146	
113	Chain Stopper Link		1	L5BA0329045	
114	Stopper Assembly		1		ER1ES1041

9.5 15 & 20 Ton Suspension and Chaining Parts



9.5 15 & 20 Ton Suspension and Chaining Parts

Fig. No.	Part Name	Qty per Hoist	Capacity (T)		
			15	20	
54	Top Hook Set	1	M3001A150	M3001A200	
	55	Top Hook	1	M3001150	M3001A200
	56	Latch Assembly	1	M3072150	M3072200
	57	Idle Sheave Assembly	()	M31051150 (2)	M31051150 (3)
	62	Top Suspension Shaft	2	M3010150	M3010200
	63	Top Yoke A	1	M3016150	M3011200
		Top Yoke B	1	M3017150	M3011200
	64	Top Plate A	1	M35012150	M35012200
		Top Plate B	1	M3014150	M35012200
	65	Guide	()	M3018150 (4)	M3018150 (6)
	66	Stay Bolt	2	M3019150	M3019200
		Top Plate	1	M3043150	
	67	Top Shaft	1	M3053150	M3053200
	68	Key Plate	2	M2056150	
		Collar	2	M3066150	
	70	Socket Bolt	4	9091270	
	71	Nut	4	9093458	
	72	Nut	4	9093445	
	73	Spring Washer	4	9012711	
74	Spring Washer	4	9012717		
75	Spring Washer	4	9012721		
77	Bottom Hook Set	1	M3021A150	M3021A200	
	78	Bottom Hook	1	M3021150	M3021200
	80	Latch Assembly	1	M3072150	M3072200
	81	Idle Sheave Assembly	()	M31051150 (3)	M31051150 (4)
	86	Guide	()	M3018150 (6)	M3018150 (8)
	87	Hook Support	2	M3026150	M3026200
	88	Bottom Yoke	1	M3030150	M3030200
	89	Bottom Plate A	()	M3034150 (1)	M3034200 (2)
	90	Bottom Plate B	1	M3035150	M3035200
	91	Bottom Plate C	1		M3036200
	92	Stay Bolt	4	M3038150	M3038200
	93	Collar A	2		M3039200
	94	Collar B	4		M3040200
	95	Bottom Shaft	1	M3054150	M3054200
	96	Key Plate	2	M2056150	
	97	Washer A	2		M3058200
	98	Collar	4		M3066200
	99	Nameplate A w/ Rivets	1	M3069150	M3069200
	100	Socket Bolt	4	9091270	
	101	Nut	8	9093445	
102	Spring Washer	4	9012711		
103	Spring Washer	8	9012717		
104	Tongued Washer	4	M3091150		
105	Bolt	4	9093350		

9.5 15 & 20 Ton Suspension and Chaining Parts

Fig. No.	Part Name		Qty per Hoist	Capacity (T)	
				15	20
106	Chain Pin		1	M3041075	
107	Slotted Nut		1	M2049020	
108	Split Pin		1	9009412	
109	Nameplate B w/ Rivets		1	M3B800150	M3B800200
110	Load Chain	Black	ft	LCC3025	
		Nickel Plated		LCC3025NP-DIN	
111	Hand Chain	Plain	ft	HCCF005MLA	
		Zinc		HCCF005ZNMLA	
		Stainless Steel		K7RA0500000	
117	Hand Chain Master link	Plain	1	HCCF005MLA	
		Zinc		HCCF005ZNMLA	
		Nickel Plated		C1FA0159843N	
112	Warning Tag (WTAG9)		()	80146 (1)	80146 (2)
113	Chain Stopper Link		()	L5BA0329045 (1)	L5BA0329045 (2)
114	Stopper Assembly		()	ER1ES1041 (1)	ER1ES1041 (2)

This Page Intentionally Left Blank

9.6 Optional Hooks

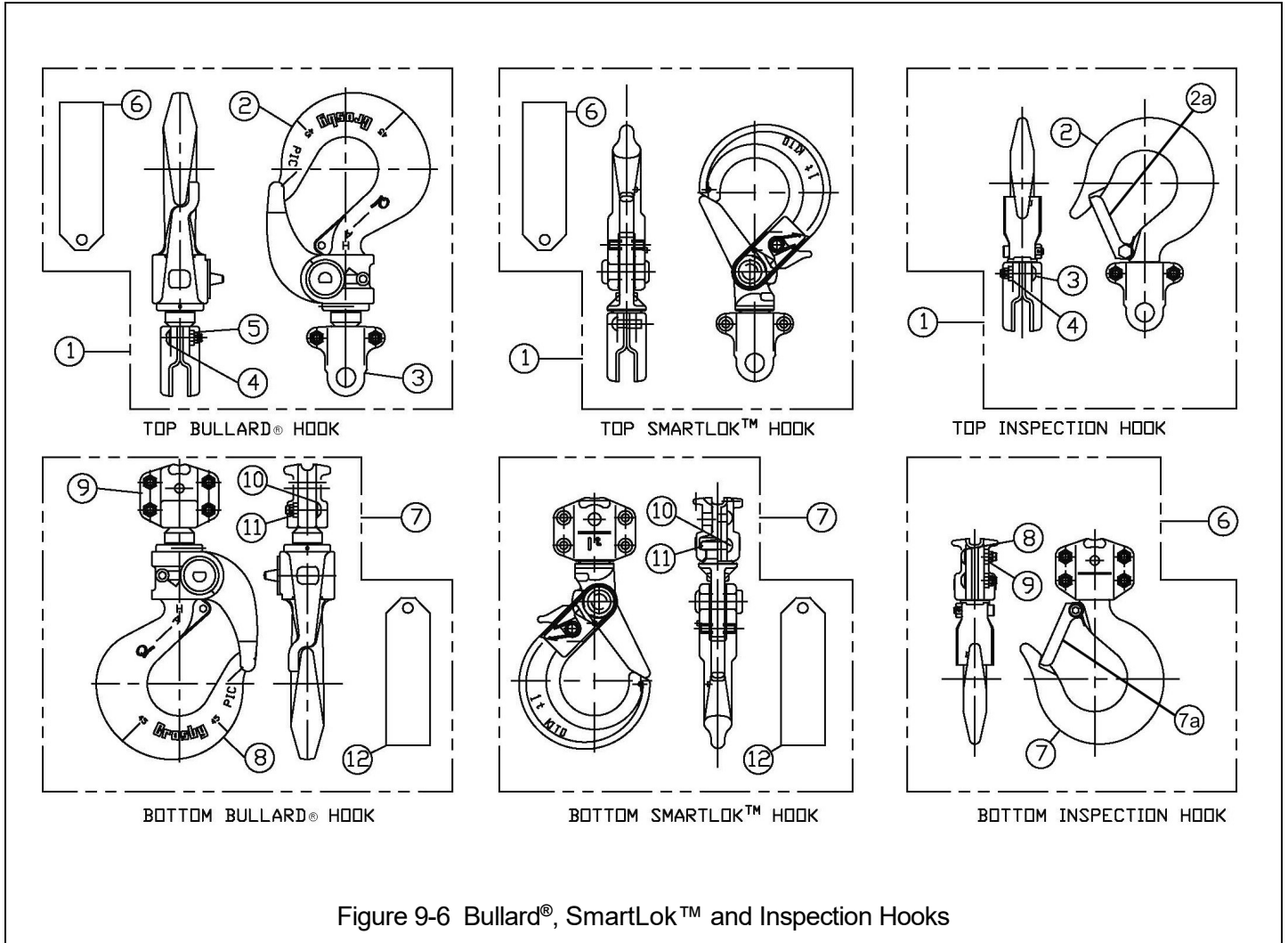


Figure 9-6 Bullard®, SmartLok™ and Inspection Hooks

Bullard® Hooks

Fig. No.	Part Name	Qty per Hoist	Capacity (T)							
			½	1	1½	2	2½	3	5	
1	Bullard® Top Hook Complete Set	1	6027601	6027602	6027603	6027604	6027605			
2	Bullard® Hook Assembly	1	60160	60162	60164	60165	60166			
3	Top Yoke Kit	1	TYKITCB005	TYKITCB010	TYKITCB015	TYKITCB020	TYKITCB025			
4	Button Head Screw	2	9012612		9012602					
5	Flexloc® Nut**	2	9012613		9012604					
6	Warning Tag	1	WTAG6*							
7	Bullard® Bottom Hook Complete Set	1	6027801	6027802	6027803	6027804	6027806	6027807	6027808	
8	Bullard® Hook Assembly	1	60160	60162	60164	60165	60166	60168	60169	
9	Bottom Yoke Kit	1	BYKITCB005	BYKITCB010	BYKITCB015	BYKITCB020	BYKITCB025			
10	Button Head Screw	4	9012612		9012602			9091274	9091296	
11	Flexloc® Nut**	4	9012613		9012604			ES857005S	ES066075	
12	Warning Tag*	1	WTAG6*							

*Hoist with Bullard® Hook(s) must have WTAG6 and WTAG9 installed. (See page 6 for illustration of WTAG9).

**See Table 6-3 in Owner's Manual for yoke nut torque specifications.

9.6 Optional Hooks

SmartLok™ Hooks*

Fig. No.	Part Name	Qty per Hoist	Capacity (T)						
			1/2	1	1 1/2	2	3	5	
1	SmartLok™ Top Hook Complete Set	1	60342	60343	60344				
6	Warning Tag	1	WTAG13**						
7	SmartLok™ Bottom Hook Complete Set	1	60321	60322	60323	60324	60327	60328	
10	Button Head Screw	2					9091296		
11	Flexloc® Nut***	2					ES066075		
12	Warning Tag	1	WTAG13**						

* SmartLok™ Hook replaced Shur-loc® Hook offering in 2022.

**Hoist with SmartLok™ Hook(s) must have WTAG9 and WTAG13 installed. (See page 6 for illustration of WTAG9 and SmartLok Hook Supplement for WTAG13).

***See Table 6-3 in Owner's Manual for yoke nut torque specifications

Inspection Hooks

Fig. No.	Part Name	Qty per Hoist	Capacity (T)				
			1/2	1	1 1/2	2	2 1/2
1	Top Hook Complete Set	1	M3001A005IK	M3001A010IK	M3001A015IK	M3001A020IK	M3001A025IK
2	Hook with Latch & Yoke	1	M3001A005IH	M3001A010IH	M3001A015IH	M3001A020IH	M3001A025IH
2a	Top Latch Assembly	1	CF071005	CF071010	CF071015	CF071020	CF071030
3	Button Head Screw	2	9012612			9012602	
4	Flexloc® Nut*	2	9012613			9012604	
6	Bottom Hook Complete Set	1	M3021A005IK	M3021A010IK	M3021A015IK	M3021A020IK	M3021A025IK
7	Hook with Latch & Yoke	1	M3021A005IH	M3021A010IH	M3021A015IH	M3021A020IH	M3021A025IH
7a	Bottom Latch Assembly	1	CF071005	CF071010	CF071015	CF071020	CF071030
8	Button Head Screw	2	9012612			9012602	
9	Flexloc® Nut*	2	9012613			9012604	

*See Table 6-3 in Owner's Manual for yoke nut torque specifications.

9.7 Optional Canvas Chain Containers

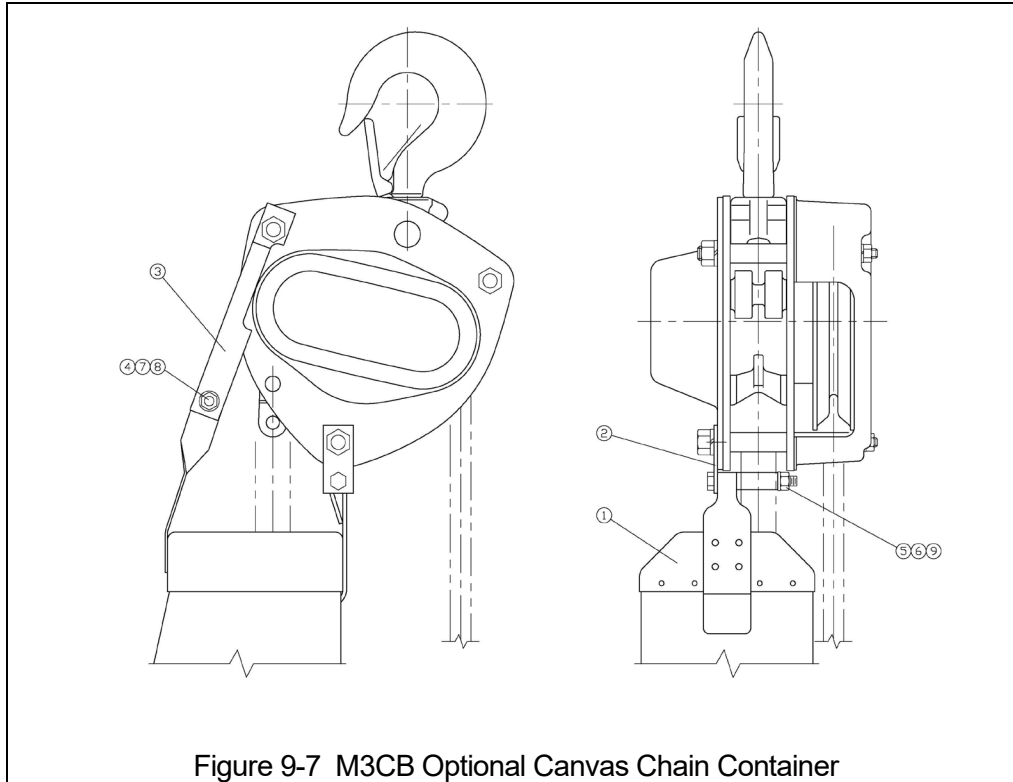


Figure 9-7 M3CB Optional Canvas Chain Container

OPTIONAL CANVAS CHAIN CONTAINERS

Fig. No.	Name	Parts Per Hoist	Capacity (T)							
			½	1	1½	2	2½	3	5	8
	"05" Chain Container (BKC1) Assy / Max Lift (ft)	1	60461 (39)		60461 (28)	60463 (22)		60461 (14)	60463 (11)	
1	Chain Container	1	50545			50545	50545	50545		
2	Front Hanger Ass'y	1	5048305			5048305	5048305	5048305		
3	Back Hanger	1	5048304			50940	5048304	50940		
4	Washer	2	9012513			9012513	9012513	9012513		
5	Nut	1	9093424			9093424	9093424	9093424		
6	Lock Washer	1	9005310			9005310	9005310	9005310		
7	Hex Head Bolt	1	9093327			9093327	9093327	9093327		
8	Lock-Nut	1	9098506			9098506	9098506	9098506		
9	Spacer	1				5048301		5048301		
	"10" Chain Container (BKD1) Assy / Max Lift (ft)	1	60462 (68)		60462 (49)	60464 (39)	60464 (38)	60462 (24)	60464 (19)	60464 (13)
1	Chain Container	1	30090			30090		30090		30090
2	Front Hanger Ass'y	1	5048305			5048305		5048305		5048305
3	Back Hanger	1	5048304			50940		5048304		50940
4	Washer	2	9012513			9012513		9012513		9012513
5	Nut	1	9093424			9093424		9093424		9093424
6	Lock Washer	1	9005310			9005310		9005310		9005310
7	Hex Head Bolt	1	9093327			9093327		9093327		9093327
8	Lock-Nut	1	9098506			9098506		9098506		9098506
9	Spacer	1				5048301				5048301

NOTES

NOTES

NOTES



Harrington Hoists, Inc.
401 West End Avenue
Manheim, PA 17545

www.harringtonhoists.com

Toll Free: 800-233-3010
Phone: 717-665-2000
Fax: 717-665-2861

© HARRINGTON HOISTS, INC.
ALL RIGHTS RESERVED

M3CBOM-ENG