

VersaReel™ Manual



CONDUCTIX INCORPORATED

The technical data and images which appear in this manual are for informational purposes only. **NO WARRANTIES, EXPRESS OR IMPLIED, INCLUDING WARRANTIES OF MERCHANTABILITY OR FITNESS FOR A PARTICULAR PURPOSE, ARE CREATED BY THE DESCRIPTIONS AND DEPICTIONS OF THE PRODUCTS SHOWN IN THIS MANUAL.** Conductix makes no warranty (and assumes no liability) as to function of equipment or operation of systems built according to customer design or of the ability of any of its products to interface, operate or function with any portions of customer systems not provided by Conductix.

Seller agrees to repair or exchange the goods sold hereunder necessitated by reason of defective workmanship and material discovered and reported to Seller within one year after shipment of such goods to Buyer.

Except where the nature of the defect is such that it is appropriate, in Seller's judgment, to effect repairs on site, Seller's obligation hereunder to remedy defects shall be limited to repairing or replacing (at Seller's option) FOB point of original shipment by Seller, any part returned to Seller at the risk and cost of Buyer. Defective parts replaced by Seller shall become the property of Seller.

Seller shall only be obligated to make such repair or replacement if the goods have been used by Buyer only in service recommended by Seller and altered only as authorized by Seller. Seller is not responsible for defects which arise from improper installation, neglect, or improper use or from normal wear and tear.

Additionally, Seller's obligation shall be limited by the manufacturer's warranty (and is not further warranted by Seller) for all parts procured from others according to published data, specifications or performance information not designed by or for Seller.

Seller further agrees to replace or at Seller's option to provide a refund of the sales price of any goods that do not conform to applicable specifications or which differ from that agreed to be supplied which non-conformity is discovered and forthwith reported to Seller within thirty (30) days after shipment to the Buyer. Seller's obligation to replace or refund the purchase price for non-conforming goods shall arise once Buyer returns such goods FOB point of original shipment by Seller at the risk and cost of Buyer. Goods replaced by Seller shall become the property of Seller.

There is no guarantee or warranty as to anything made or sold by Seller, or any services performed, except as to title and freedom from encumbrances and, except as herein expressly stated and particularly, and without limiting the foregoing, **there is no guarantee or warranty, express or implied, of merchantability or of fitness for any particular purpose or against claim of infringement or the like.**

Seller makes no warranty (and assumes no liability) as to function of equipment or operation of systems built to Buyer's design or of the ability of any goods to interface, operate or function with any portions of Buyer's system not provided by Seller.

Seller's liability on any claim, whether in contract, tort (including negligence), or otherwise, for any loss or damage arising out of, connected with, or resulting from the manufacture, sale, delivery, resale, repair, replacement or use of any products or services shall in no case exceed the price paid for the product or services or any part thereof which give rise to the claim. In no event shall Seller be liable for consequential, special, incidental or other damages, nor shall Seller be liable in respect of personal injury or damage to property not the subject matter hereof unless attributable to gross misconduct of Seller, which shall mean an act or omission by Seller demonstrating reckless disregard of the foreseeable consequences thereof.

Seller is not responsible for incorrect choice of models or where products are used in excess of their rated and recommended capacities and design functions or under abnormal conditions. Seller assumes no liability for loss of time, damage or injuries to property or persons resulting from the use of Seller's products. Buyer shall hold Seller harmless from all liability, claims, suits, and expenses in connection with loss or damage resulting from operation of products or utilization of services, respectively, of Seller and shall defend any suit or action which might arise there from in Buyer's name - provided that Seller shall have the right to elect to defend any such suit or action for the account of Buyer. The foregoing shall be the exclusive remedies of the Buyer and all persons and entities claiming through the Buyer.

CONDUCTIX-WAMPFLER FIELD SERVICE

Need Field Service for our products? We Can Handle It!

Ask us for a quote on expert system installations, inspections, preventative maintenance, and repairs/retrofits.

As the world's largest single source manufacturer of mobile electrification products, Conductix-Wampfler has the unique ability to offer a degree of service not found anywhere else. Conductix-Wampfler's team of highly qualified service technicians and engineers have years of experience servicing our complete line of products.

We can provide:

- Annual service contracts
- Installation
- Commissioning
- Installation supervision to ensure your installers avoid common mistakes.
- Troubleshooting to get you up and running.
- Pre-planned inspections to complement your preventive maintenance program.

Call 1.800.521.4888 for further details.



TABLE OF CONTENTS

SECTION 1 - SAFETY	5
Safety Information Responsibility	5
Safety Messages	5
Electrical Warnings	6
Operational Warnings	6
Maintenance Warnings	6
UL Rating	6
Labels and Marking	6
SECTION 2 - OVERVIEW	7
SECTION 3 - INSTALLATION	8
Mounting	8
Standard Mounting	8
Reel Deflection	8
Guide Arm Position Adjustment	9
SECTION 4 - OPERATION	10
Overview	10
SECTION 5- REPLACING PARTS	11
Quick Mount Base	11
Guide Arm	12
Ball Stop	13
Spring Motor	14
Cable and Tri-Tap	15
Ground Fault Interrupter (GFCI)	17
Cable End Accessory	17
Pivot Base	18
SECTION 6 - TROUBLESHOOTING	19
SECTION 7 - REPLACEMENT PARTS	20

SECTION 1 - SAFETY

Safety Information Responsibility

All owner, operator, and maintenance personnel must read and understand all manuals associated with this product before installation, operation, or maintenance.

The manual provides information on the recommended installation, operation, and maintenance of this product. Failure to read and follow the information provided could cause harm to yourself or others and/or cause product damage. No one should install, operate, or attempt maintenance of this product prior to familiarizing themselves with the information in this manual.

Safety Messages

Safety messages in this manual are preceded by the HAZARD SYMBOL and one of three words: CAUTION, DANGER, OR WARNING. These safety messages are intended to alert you to potential hazards that could cause harm to you or others and/or cause product damage.

CAUTION

- The HAZARD SYMBOL used with the word CAUTION indicates unsafe actions or situations that have the potential to cause injury, and/or minor equipment or property damage.

DANGER

- The HAZARD SYMBOL used with the word DANGER describes immediate hazards that have the potential to cause severe personal injury or death.

WARNING

- The HAZARD SYMBOL used with the word WARNING describes unsafe actions or situations that have the potential to cause severe injury, death, and/or major equipment or property damage.

NOTE

- The word NOTE is used to alert you to installation, operation, programming, or maintenance information that is important, but not hazard related.

SECTION 1 - SAFETY

Electrical Warnings



WARNING

- Properly ground this equipment before use in accordance with both the National Electric Code and local electrical codes and ordinances.
- Disconnect the electrical power from the cable reel before any service functions are performed.
- Do not use this cable reel for loads greater than the current rating listed on the label or voltage greater than 120V.
- Electrical wiring on the reel must be done by a qualified electrician.

Operational Warnings



WARNING

- Exercise care when handling the cable reel during normal operation. This cable reel has a rotating spool powered by springs under tension.
- For use in indoor, dry location only.
- Do not allow cable to retract without restricting the retraction speed.

Maintenance Warnings



WARNING

- Do not install cable different from that for which the reel is intended. Changes in diameter, weight per foot, length of cable, or flexibility will affect the operation of the reel.
- Mounting hardware and fasteners should be installed to maintain tightness under vibration and checked periodically to assure tightness.
- Overhead installation mountings should be such that the reel is not suspended by bolts in tension. A safety chain or cable is strongly recommended to minimize damage and/or possible injury in the event of mounting failure.
- Do not disassemble the spring motor for any reason. Serious personal injury could result. This cable reel is equipped with springs under tension. Contact the factory for assistance:
In the US call: 1-800-521-4888
In Canada call: 1-800-667-2487

UL Rating

All reels in catalog are cULus listed.

Listed cable reels are intended for general use and are provided with permanent mounting means. If not completely wired from the factory, any needed electrical wiring or connections must be done by a qualified electrician.

Labels and Marking

Every cable reel is marked with a label which includes the Conductix-Wampfler name and logo, the product catalog number, the individual product serial number, NEMA rating, amps, volts, watts, and cable footage.

SECTION 2 - OVERVIEW

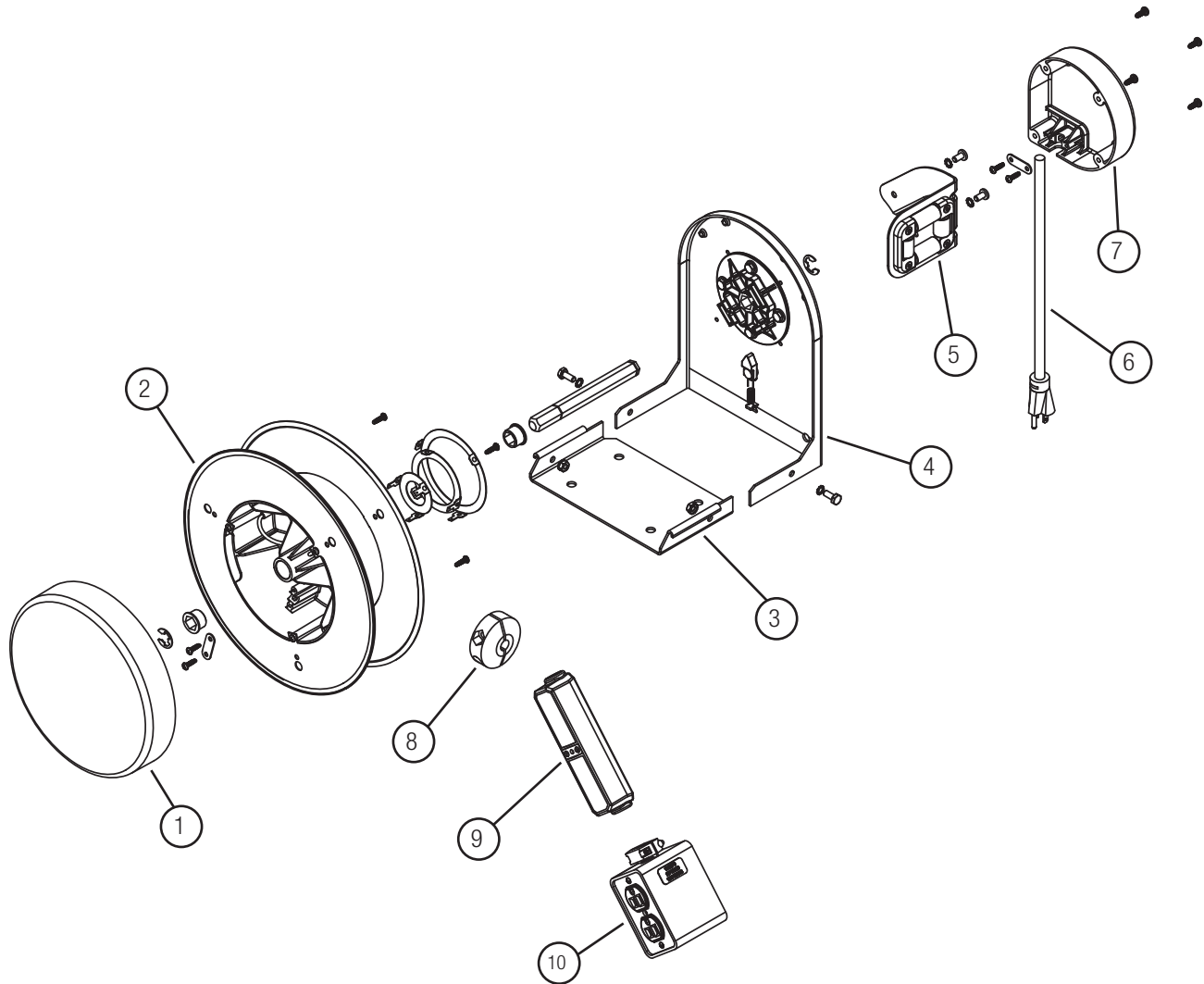

- 1. Spring Motor
- 2. Spool
- 3. Base
- 4. Frame
- 5. Guide Arm

- 6. Feeder Cord
- 7. Feeder Cord Cover
- 8. Ball Stop
- 9. GFCI
- 10. End Accessory

SECTION 3 - INSTALLATION

Mounting

Standard Mounting

The reel may be mounted by bolting the base to any flat surface which is structurally sound and can support the weight of the reel and the forces of winding and unwinding the reel.

The spool must rotate on a horizontal axis for proper operation.

The reel must be oriented so that the cable extends perpendicular to the rotation of the spool. The total cable deflection should not exceed 30°. See **Figure 8-2**.

While mounting the reel, the installer must always safely support the weight of the reel. The reel should not be left hanging unsupported without the base mounting hardware properly installed and torqued.

1. Unbolt the base hardware and remove the mounting base from the frame of the cord reel. See **Figure 8-1**.
2. Securely mount the base in the desired location.
3. Insert the reel into the base. Please note the reel will only install into the base in one direction.
4. Re-install the base mounting hardware and torque hardware to 50 in-lbs.

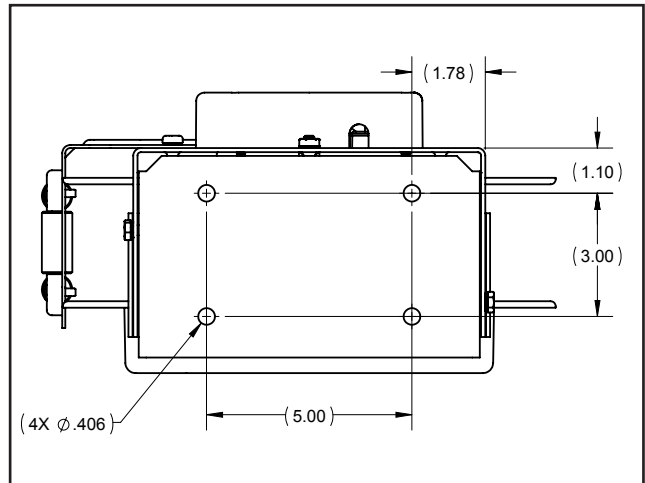

Figure 8-1 Underside of Mounting Base

Reel Deflection

If deflection is constant to either side of the reel and operation is impaired, re-mount the reel.

We recommend a safety chain for all overhead installations.

Attach the safety chain using the 0.39 hole provided in the base. See **Figure 8-2**.

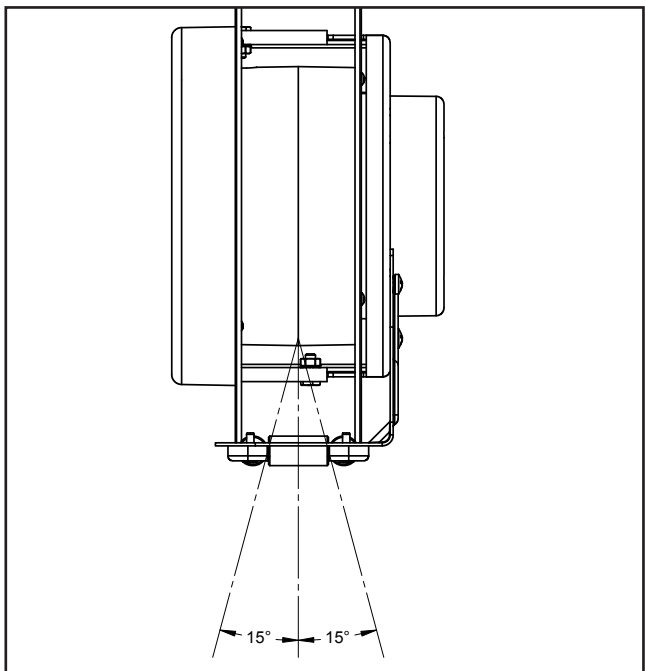
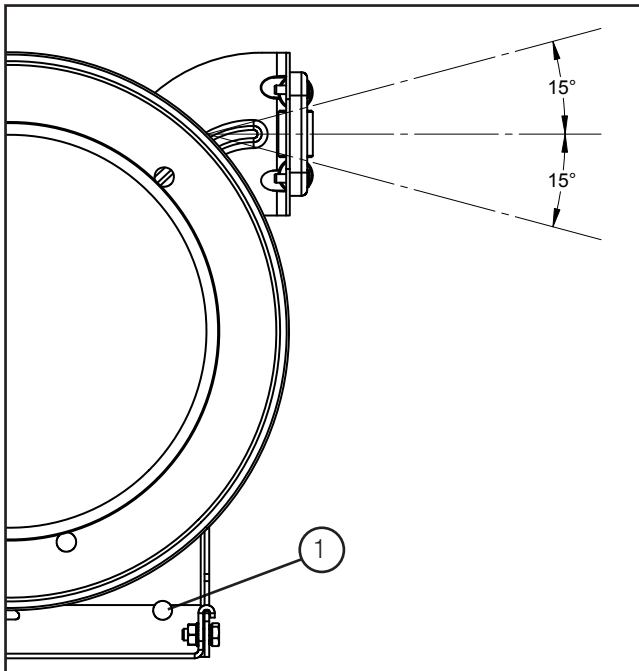

Figure 8-2 Cable Deflection with Roller Guide

1. Safety Chain Hole

SECTION 3 - INSTALLATION

Guide Arm Position Adjustment

The guide arm can be mounted in two positions.

1. Slowly unspool a small amount of cable until the reel begins to click and the spool ratchet engages.
2. Unscrew the two phillips screws. **See Figure 9-1.**
3. Position the guide arm in the desired orientation and re-install the two phillips screws. Position 1 shows the correct position for a wall mount, and Position 2 is the correct position for a ceiling mount.
4. Torque the screws to 18 in-lbs.

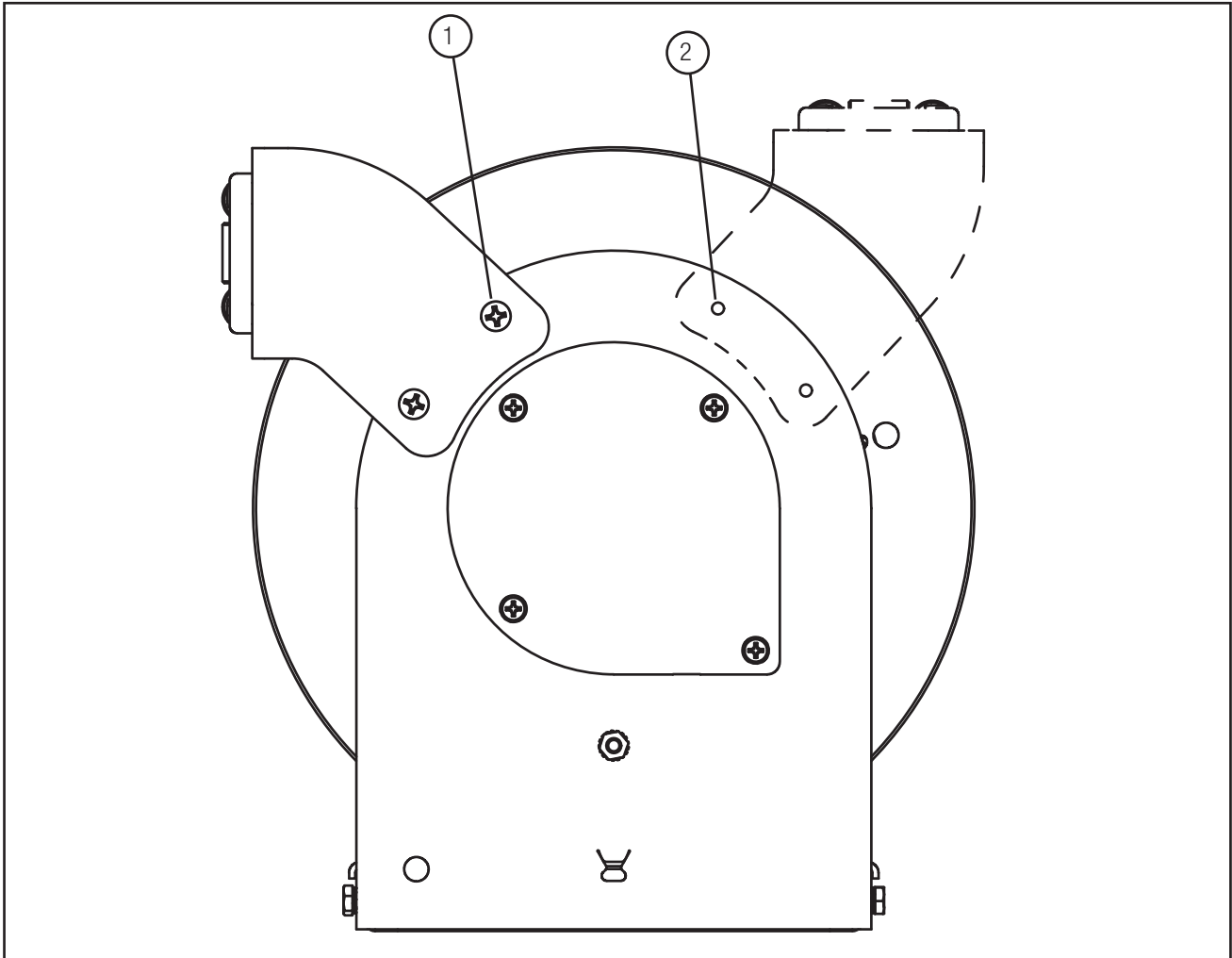

Figure 9-1 Guide Arm Positions

SECTION 4 - OPERATION

Overview

Do not exceed the voltage or amperage rating of the reel. Overheating, fire, damage to equipment, or personal injury could result.

Do not allow cable to retract without restraining the retraction speed.

Operate the reel within the cable size, cable length, and spring tensioning limits for which it was intended.

NOTE

- Two wraps of cable should remain on the reel at maximum extension to avoid excessive tension on the cable entrance.

Keep the reel and cable clean to avoid excessive wear and damage.

Discontinue use and arrange for maintenance service if damage is found on the cable or reel.

Cable should be fully retracted when not in service to maximize spring life.

SECTION 5- REPLACING PARTS

CAUTION

- Reel weight requires care to be taken when removing reel from base.

WARNING

Ensure that all power is disconnected from the reel prior to performing any tasks in Section 5.

Quick Mount Base

Tools needed: 7/16" wrench, 7/16" socket wrench, ratchet, torque wrench.

1. Remove quick mount base from reel by removing 1/4" hardware that attaches the frame's legs to the base. **The entire weight of the reel must be supported during this process.** (Figure 11-1)
2. Properly secure the new base to the mounting structure. (Figure 11-2)
3. Once the quick mount base is secured to the mounting structure, slide the frame legs into the flange tabs on the base to connect the reel to the base. (Figure 11-3)
4. While supporting the reel's weight, align the frame holes with the base holes and insert the 1/4" hardware on both sides and tighten to 6 ft-lbs. (Figure 11-4)



Figure 11-1

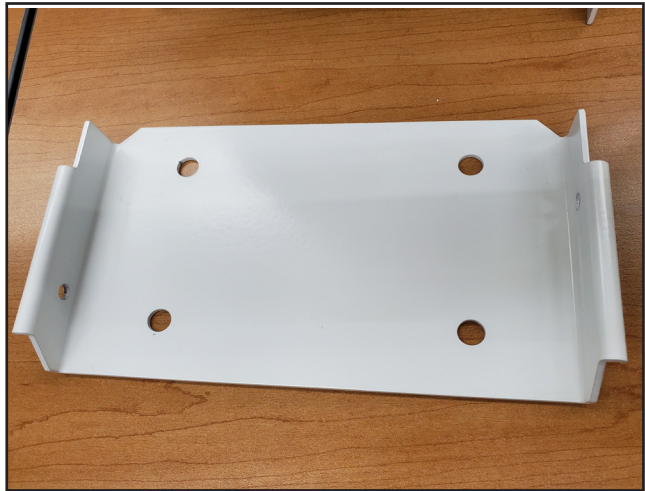

Figure 11-2

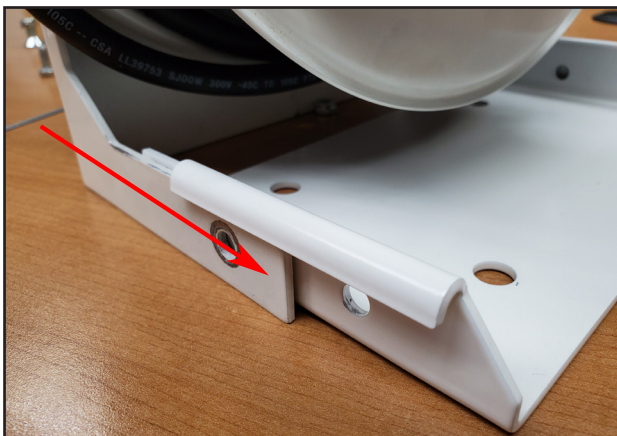

Figure 11-3



Figure 11-4

SECTION 5 - REPLACING PARTS

Guide Arm

Tools needed: Phillips or Torx head screwdriver.

1. Keep reel from spinning by locking in place on ratchet. Remove ball stop. Remove guide arm. **See Figure 12-1.**
2. Remove any cable end accessory and GFCI if installed on cable. See cable end accessory and GFCI replacement instructions.
3. Install new guide arm by inserting cable through cable opening. **See Figure 12-2.**
4. Re-attach arm to reel using the same screws and tighten down. Torque to 50 inch lbs. **See Figure 12-1.**
5. Re-attach ball stop, cable accessory and GFCI if needed. See cable end accessory and GFCI replacement instructions.



Figure 12-1

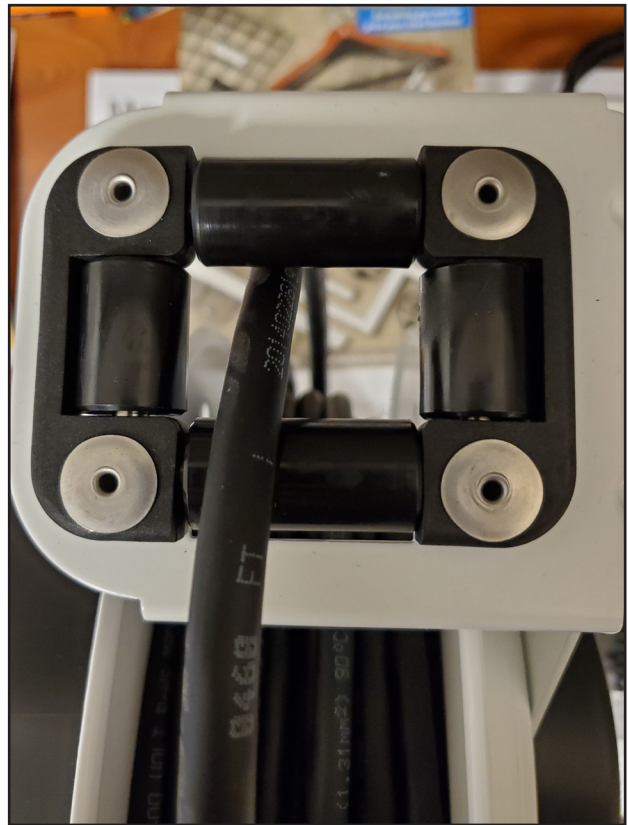

Figure 12-2

SECTION 5 - REPLACING PARTS

Ball Stop

Tools needed: Phillips screwdriver.

1. Keep reel from spinning by locking in place on ratchet.
2. Attach new ball stop on cable in location for application. See **Figure 13-1** and **Figure 13-2**.
 - A. Remove screws completely to replace ball stop.
 - B. Loosen and move ball stop along cable to adjust hanging length.

NOTE

- Donut-style ball clamp used on reels using 12/3 cable, clamp style used on reels with 16/3 cable.



Figure 13-1

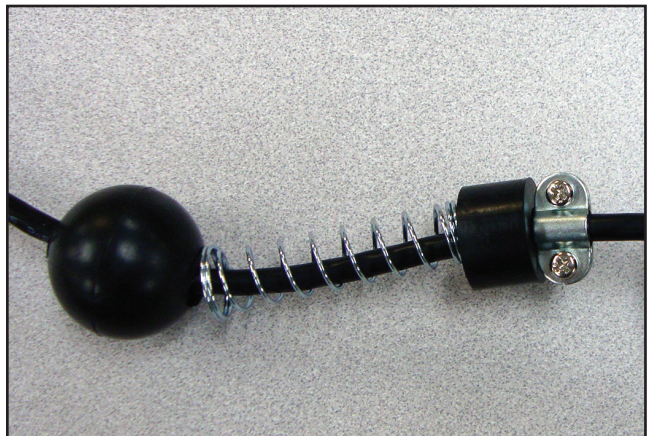

Figure 13-2

SECTION 5 - REPLACING PARTS

Spring Motor

Tools needed: Phillips or Torx head screwdriver.

1. **Remove all tension on spring** by removing guide arm and having a controlled spool retraction. Let reel retract completely while holding on to guide arm and cable accessory to prevent damage to reel.
2. Remove cable off spool by lifting over and off of flange. Remove enough cable to expose spring motor screws. **See Figure 14-1.**
3. Remove spring motor by removing the 3 screws attaching it to the flange. **See Figure 14-2.**

WARNING

- Never take apart spring motor assembly.

4. Re-attach new spring motor to shaft. **See Figure 14-3.**
NOTE: Ensure hex shaft is properly inserted into spring arbor of the motor.
5. Attach new spring motor to flange with screws. Tighten 3 screws down properly. Torque to 20 inch lbs. **See Figure 14-2.**
6. Hand wind cable back on spool. Make sure cable is spooled on tightly and evenly preventing uneven and loose stack up. **See Figure 14-4.**
7. Place 6 pre turns in reel by winding reel forward 6 full revolutions. Keep a hold of reel during pre-turning to prevent retraction. **See Figure 14-5**
8. Once pre-turns are placed tensioning the reel, lock the reel out on ratchet to prevent retraction.
9. Re-attach guide arm. Torque screws to 50 inch lbs.



Figure 14-1



Figure 14-2



Figure 11-3



Figure 11-4

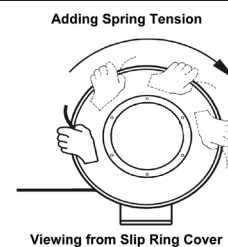

Figure 14-5

SECTION 5 - REPLACING PARTS

Cable and Tri-Tap

Tools needed: phillips screw driver, electrical wire crimpers, proper wire connectors.

1. Remove Spring Motor (see Page 11.)
2. Remove strain relief bracket. See **Figure 15-1**.
3. Remove cable wires from quick connector. See **Figure 15-1**.
4. Install new cable or cable with tri-tap through slot in drum. See **Figure 15-2**.
 - For Tri-Tap without GFCI, install cable through guide arm before wiring.

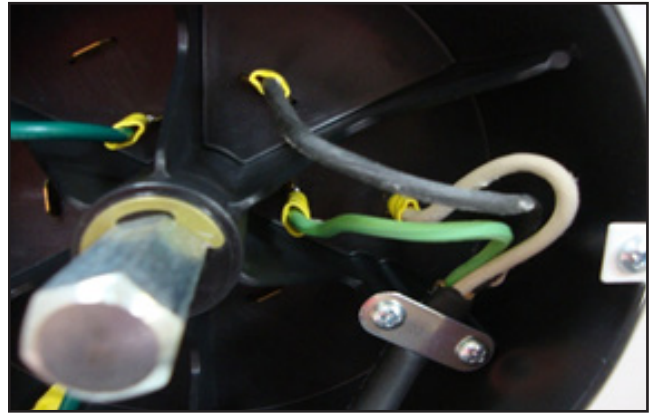

Figure 15-1



Figure 15-2

SECTION 5 - REPLACING PARTS

5. Strip cable properly and install proper cable connector to each wire with crimper. See **Figure 16-1**.
6. Attach connector to correct corresponding quick connector inside drum. See **Figure 16-2** and **Figure 16-3**.
 - Black wire connected to wire from #2 hole.
 - White wire connected to wire from #3 hole.
 - Green wire connected to #GRD hole. See **Figure 16-4**.
7. Re-attach strain relief bracket. See **Figure 16-2**.
8. Re-attach spring motor. See **Page 11 Spring Motor Replacement**.
9. Attach ball stop in proper location.
10. Attach GFCI if applicable. See GFCI installation instructions
11. Attach desired end accessory. See cable end accessory instructions



Figure 16-1

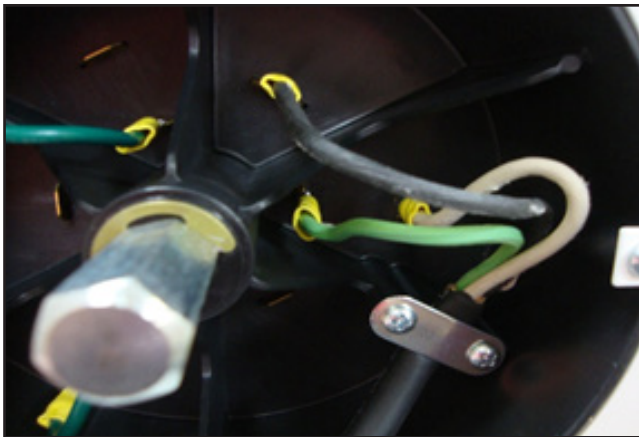

Figure 13-2



Figure 13-3

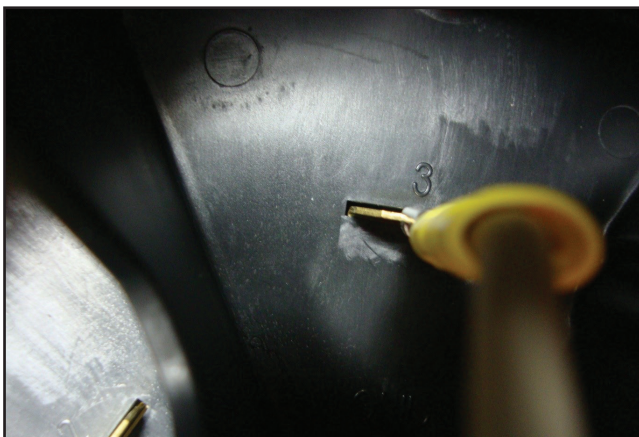

Figure 13-4

SECTION 5 - REPLACING PARTS

Ground Fault Interrupter (GFCI)

Tools needed: Phillips head screwdriver.

1. Remove existing GFCI by removing each end cover. **See Figure 17-1.**
2. On both sides, remove strain relief bracket, cable gasket and disconnect wires from connectors. **See Figure 17-2.**
3. Install new GFCI 5 from cable accessory in the same location as the old GFCI. **See Figure 17-3.**
4. Install cable gaskets to both sections of cable before connecting the new GFCI. **See Figure 17-2.**

NOTE

- Make sure GFCI is installed in correct orientation of the line and load labeled on GFCI: "Line" towards the spool side and "load" towards the end accessory side
5. Connect wires to connector on both ends and install strain relief. **See Figure 17-2.**
 - White wire to silver screw.
 - Green wire to green screw.
 - Black wire to brass screw.
 6. Re-attach GFCI covers. Make sure gasket has proper placement in case. **See Figure 17-2.**

Cable End Accessory

1. Remove existing accessory.
2. Install desired end accessory.
3. Follow proper wiring instructions for type and style of accessory:
 - A. If required, strip cable jacket and wires to correct length.
 - B. Attach black, white and green wire to correct accessory connection.
 - C. Correctly install any strain relief plates or nuts included with accessory.



Figure 17-1



Figure 17-2



Figure 17-3

SECTION 5 - REPLACING PARTS

Pivot Base

Tools needed: 9/16" and 7/16" wrench, 7/32" Allen wrench, 7/16" socket, ratchet, and torque wrench.

1. Remove the 1/4" hardware attaching the quick mount frame to the base (See Figure 18-1.). **The entire weight of the reel must be supported during this process.** Align the four holes in the pivot base mounting plate to the holes in the quick mount base.
2. Insert the 3/8" flat screws from the bottom through both plates, attach lock nuts, and tighten to 20 ft-lbs. See Figure 18-2.
3. Attach and secure both bases to the mounting structure (See Figure 18-3). **Pivot base is for ceiling or table mounts only-NO wall mounting.**
4. Once quick mount base is securely mounted, attach reel by sliding frame legs into the flange tabs on base (See Figure 18-4).
5. While supporting the reel's weight, align the frame holes with the base holes, insert 1/4" hardware and tighten to 6 ft-lbs. See Figure 18-5.



Figure 18-1

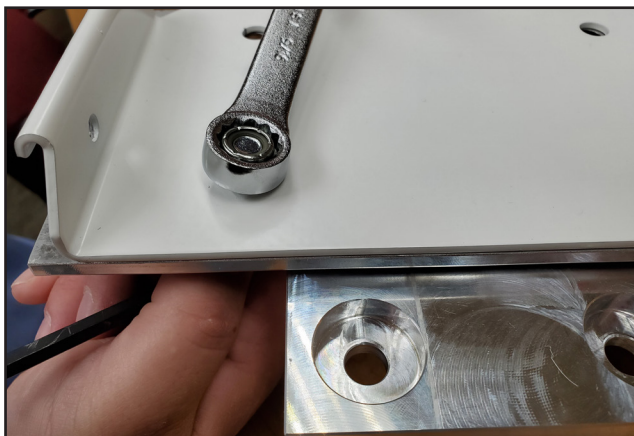

Figure 18-2



Figure 18-3



Figure 18-4



Figure 18-5

SECTION 6 - TROUBLESHOOTING

PROBLEM	POSSIBLE CAUSE	SOLUTION
Reel will not retract cable but has some tension	<ul style="list-style-type: none"> • Improper cable or cable length installed • Cable guide adjustment 	<ul style="list-style-type: none"> • Install correct cable type and length • Check guide alignment
Reel does not have spring tension	<ul style="list-style-type: none"> • Broken spring 	<ul style="list-style-type: none"> • Replace spring motor
Ratchet will not engage	<ul style="list-style-type: none"> • Broken ratchet pawl spring 	<ul style="list-style-type: none"> • Replace ratchet pawl spring
Ratchet will not disengage	<ul style="list-style-type: none"> • Over-extension of reel 	<ul style="list-style-type: none"> • Manually rotate reel spool to disengage ratchet. Do not over-extend (guide adjustment may prevent lock-up when over-extended) • Adjust ball stop
Cable wraps improperly (uneven wrapping, wraps above or jumps flange)	<ul style="list-style-type: none"> • Reel mounting not level • Cable retraction rate too high • Cable guide out of adjustment • Improper cable or cable length installed 	<ul style="list-style-type: none"> • Mount reel on level surface • Maintain steady retraction rate • Properly adjust cable guide • Install correct cable type and length
Cable twisting or knotting	<ul style="list-style-type: none"> • Reel mounted in improper orientation • Improperly installed cable • Cable rubbing on or bending around fixed object • Inadequate anchoring of cable 	<ul style="list-style-type: none"> • See cable installation section in maintenance manual • Check roller guide for function and cable pay out path
Open or intermittent circuit	<ul style="list-style-type: none"> • Inadequate wiring or feeding circuit • Loss of brush contact to slip ring • Cable defective • Cable guide out of adjustment • Dirt or contaminants on slip ring 	<ul style="list-style-type: none"> • Check all termination points • Check brush wear, spring tension and, alignment • Perform continuity check on cable at termination points
Circuit arcing	<ul style="list-style-type: none"> • Amp or voltage above rating of reel • Excessive carbon dust accumulation • Loss of brush to ring contact 	<ul style="list-style-type: none"> • Clean dust from inside slip ring • Replace brush assembly

SECTION 7 - REPLACEMENT PARTS

Part Number	Description	Notes
XA-41043	Feeder Cord	20A
XA-41042	Feeder Cord	15A, 10A
XA-573396	Feeder Cord Cover	
XA-577828	Cable 12/3 SJ00W	105°C
XA-33018	Cable 16/3 S00W 90°C	90°C
XA-577872	Cable Tri-Tap 12/3 SJ00W	90°C
XA-578566	Cable Tri-Tap 16/3 S00W	90°C
XA-34474	Ball Stop 12/3	
XA-34885	Ball Stop 16/3	
XA-577878	GFCI Inline 12/3	
XA-578852	Quad Receptable Box	10A
XA-578853	Quad Receptable Box	15A
XA-578854	Quad Receptable Box	20A
XA-51302	Single Outlet	10A, 15A
XA-37464	Single Outlet	20A
XA-577871	Locking Outlet	10A, 15A
XA-540975	Locking Outlet	20A
XA-573399	Spring Motor Assembly	
XA-573508	Quick Mount Base	



www.conductix.us

USA / LATIN AMERICA

10102 F Street
Omaha, NE 68127

Customer Support
Phone +1-800-521-4888

Phone +1-402-339-9300
Fax +1-402-339-9627

info.us@conductix.com
latinamerica@conductix.com

CANADA

1435 Norjohn Court
Unit 5
Burlington, ON L7L 0E6

Customer Support
Phone +1-800-667-2487

Phone +1-450-565-9900
Fax +1-450-951-8591

info.ca@conductix.com

MÉXICO

Calle Treviño 983-C
Zona Centro
Apodaca, NL México 66600

Customer Support
Phone (+52 81) 1090 9519
(+52 81) 1090 9025
(+52 81) 1090 9013

Fax (+52 81) 1090 9014

info.mx@conductix.com

BRAZIL

Rua Luiz Pionti, 110
Vila Progresso
Itu, São Paulo, Brasil
CEP: 13313-534

Customer Support
Phone (+55 11) 4813 7330

Fax (+55 11) 4813 7357

info.br@conductix.com

Contact USA for our Global Sales Offices

