

Conductor Bar Manual

Safe-Lec 2 Heater Wire

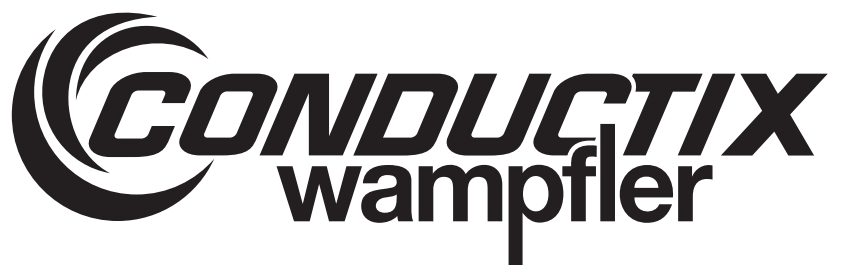

CONDUCTIX INCORPORATED

The technical data and images which appear in this manual are for informational purposes only. **NO WARRANTIES, EXPRESS OR IMPLIED, INCLUDING WARRANTIES OF MERCHANTABILITY OR FITNESS FOR A PARTICULAR PURPOSE, ARE CREATED BY THE DESCRIPTIONS AND DEPICTIONS OF THE PRODUCTS SHOWN IN THIS MANUAL.** Conductix makes no warranty (and assumes no liability) as to function of equipment or operation of systems built according to customer design or of the ability of any of its products to interface, operate or function with any portions of customer systems not provided by Conductix.

Seller agrees to repair or exchange the goods sold hereunder necessitated by reason of defective workmanship and material discovered and reported to Seller within one year after shipment of such goods to Buyer.

Except where the nature of the defect is such that it is appropriate, in Seller's judgment, to effect repairs on site, Seller's obligation hereunder to remedy defects shall be limited to repairing or replacing (at Seller's option) FOB point of original shipment by Seller, any part returned to Seller at the risk and cost of Buyer. Defective parts replaced by Seller shall become the property of Seller.

Seller shall only be obligated to make such repair or replacement if the goods have been used by Buyer only in service recommended by Seller and altered only as authorized by Seller. Seller is not responsible for defects which arise from improper installation, neglect, or improper use or from normal wear and tear. Additionally, Seller's obligation shall be limited by the manufacturer's warranty (and is not further warranted by Seller) for all parts procured from others according to published data, specifications or performance information not designed by or for Seller.

Seller further agrees to replace or at Seller's option to provide a refund of the sales price of any goods that do not conform to applicable specifications or which differ from that agreed to be supplied which non-conformity is discovered and forthwith reported to Seller within thirty (30) days after shipment to the Buyer. Seller's obligation to replace or refund the purchase price for non-conforming goods shall arise once Buyer returns such goods FOB point of original shipment by Seller at the risk and cost of Buyer. Goods replaced by Seller shall become the property of Seller.

There is no guarantee or warranty as to anything made or sold by Seller, or any services performed, except as to title and freedom from encumbrances and, except as herein expressly stated and particularly, and without limiting the foregoing, **there is no guarantee or warranty, express or implied, of merchantability or of fitness for any particular purpose or against claim of infringement or the like.**

Seller makes no warranty (and assumes no liability) as to function of equipment or operation of systems built to Buyer's design or of the ability of any goods to interface, operate or function with any portions of Buyer's system not provided by Seller.

Seller's liability on any claim, whether in contract, tort (including negligence), or otherwise, for any loss or damage arising out of, connected with, or resulting from the manufacture, sale, delivery, resale, repair, replacement or use of any products or services shall in no case exceed the price paid for the product or services or any part thereof which give rise to the claim. In no event shall Seller be liable for consequential, special, incidental or other damages, nor shall Seller be liable in respect of personal injury or damage to property not the subject matter hereof unless attributable to gross misconduct of Seller, which shall mean an act or omission by Seller demonstrating reckless disregard of the foreseeable consequences thereof.

Seller is not responsible for incorrect choice of models or where products are used in excess of their rated and recommended capacities and design functions or under abnormal conditions. Seller assumes no liability for loss of time, damage or injuries to property or persons resulting from the use of Seller's products. Buyer shall hold Seller harmless from all liability, claims, suits and expenses in connection with loss or damage resulting from operation of products or utilization of services, respectively, of Seller and shall defend any suit or action which might arise there from in Buyer's name - provided that Seller shall have the right to elect to defend any such suit or action for the account of Buyer. The foregoing shall be the exclusive remedies of the Buyer and all persons and entities claiming through the Buyer.

INDEX

1.0 Environmental Considerations

- 1.1 Environmental Specifications
- 1.2 Recommended Tools & Equipment

2.0 System Overview

- 2.1 Overview
- 2.2 How it works
- 2.3 Thermostatic Control Box
- 2.4 Cold Wire Connections
- 2.5 Requirements for Determining System

3.0 Installation & Assembly

- 3.1 General Assembly Instructions
- 3.2 Support Bracket Installation
- 3.3 Web Bracket Installation
- 3.4 Mounting Details of Conductor Hanger
- 3.5 Hanger Types
- 3.6 Anchor Support Assembly Installation
- 3.7 Assembly of Bolted Joint
- 3.8 Assembly of Expansion Section
- 3.9 Assembly of end Power Feed (100 Amp Conductor Bar Only)
- 3.10 Assembly of Joint Power Feed (up to and including 250 Amp)
- 3.11 Assembly of Joint Power Feed (over 250 Amp)
- 3.12 Assembly of Heater Center Power Feed
- 3.13 Connection of End Loop
- 3.14 Mounting Details for 50 Amp SI Collector
- 3.15 Mounting Details for 100 Amp DI Collector
- 3.16 Mounting Details for 200 Amp Collector
- 3.17 Replacement of DI & SI Collector Contact Shoe and Shoe Holder
- 3.18 Replacement of 200 Amp Collector Contact Shoe

4.0 Maintenance

- 4.1 Inspection & Maintenance Background
- 4.2 Inspection & Maintenance Frequency
- 4.3 Inspection & Maintenance of Covers
- 4.4 Inspection & Maintenance of Hanger Clamps
- 4.5 Inspection & Maintenance of Conductor
- 4.6 Inspection & Maintenance of Splice
- 4.7 Inspection & Maintenance of Anchor Clamps
- 4.8 Inspection & Maintenance of Expansion
- 4.9 Inspection & Maintenance of Power Feed
- 4.10 Inspection & Maintenance of End Cap
- 4.11 Inspection & Maintenance of Collector
- 4.12 Collector Shoe Replacement

5.0 Troubleshooting

1.0 ENVIRONMENTAL CONSIDERATIONS

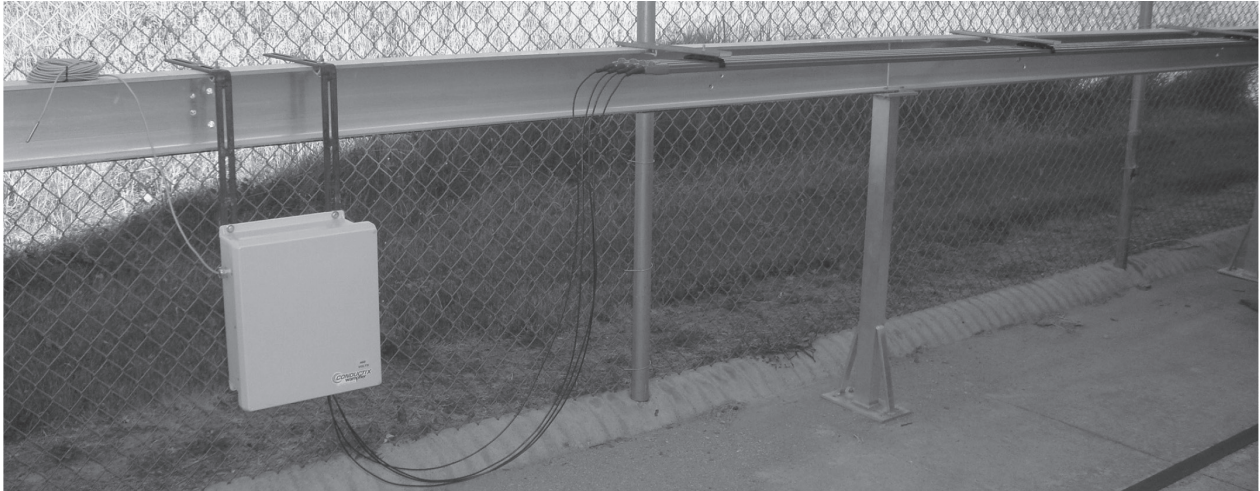

1.1 Environmental Specifications

1.1.1 Medium Heat Cover (Polycarbonate) is suitable up to 250°F (121°C)

1.1.2 The following acidic or corrosive environments require the use of stainless steel hangers:

- Hydrochloric Acid
- Hydrofluoric Acid
- Sodium Hydrochloride
- Ammonium Chloride
- Chlorine Bleach
- Chloride Ions
- Fluoride Ions

NOTE: Do not use standard (black) or medium heat (red) hangers in these environments.

1.2 Recommended Tools & Equipment

1. Man lift or platform lift for access to the installation location (if required)
2. Sharp knife – to cut power feed grommets.
3. Straight blade screwdriver – for securing feed cable to collectors and replacing collector shoes.
4. Steel rule or tape measure – to position collectors during installation.
5. Wire/cable stripper.
6. Cable lug crimping tool
7. Cordless drill with socket adapter (1/4" or 3/8" drive).
8. Deep sockets for cordless drill:
 - a. 8mm – for anchor cross bolts
 - b. 10mm – for splices, isolation sections, and power feeds
 - c. 13mm – for mounting hangers, collectors, anchors and transfer caps.
9. Torque wrench for sockets listed above.
10. Open/box end wrenches (use ratcheting box end wrenches if you have them)
 - a. 8mm
 - b. 10mm
 - c. 13mm
11. Hacksaw
12. Flat file and/or rat tail file to remove burrs on field cut conductors.
13. Pliers.
14. Heat gun.

2.0 SYSTEM OVERVIEW

2.1 In applications where the conductor is outdoors in freezing weather, the customer may want heated conductor bar to keep ice from forming. Ice formation on conductors may force the collectors to disengage causing loss of current, damage to the collectors, or to the contact shoe, or damage to the running surface of the conductor. This either stops the crane or vehicle completely or may result in pitting or burn-through of the conductor and/or collector shoes. Heater wire systems are a cost-effective means of preventing frost or ice build-up to ensure reliable system operation in cold climates. Conductix-Wampfler Safe-Lec 2 is the standard conductor we offer with heater wire. The heater wire is factory installed in each section of the conductor. During installation, the heater wire ends are plugged together at each joint and a length of heat shrink is put in place to seal the connection. If a section of conductor is damaged and needs to be replaced, the damaged section can be removed and a new section installed and wired into the heater wire system.

2.2 How it works

2.2.1 The primary components to this heater wire system:

- a. A resistance wire factory installed in the cavity of the conductor bar.
- b. A thermostatically controlled power supply.

2.2.2 This heater system automatically supplies current to the resistant wire circuit when temperatures are at 35°F (2°C) or lower. It is designed to remain on until the ambient temperature rises above 35°F (2°C). The temperature sensor should be placed near the conductor bar, in free air. A 50.0' (15m) cable is supplied connecting the sensor to the control box.

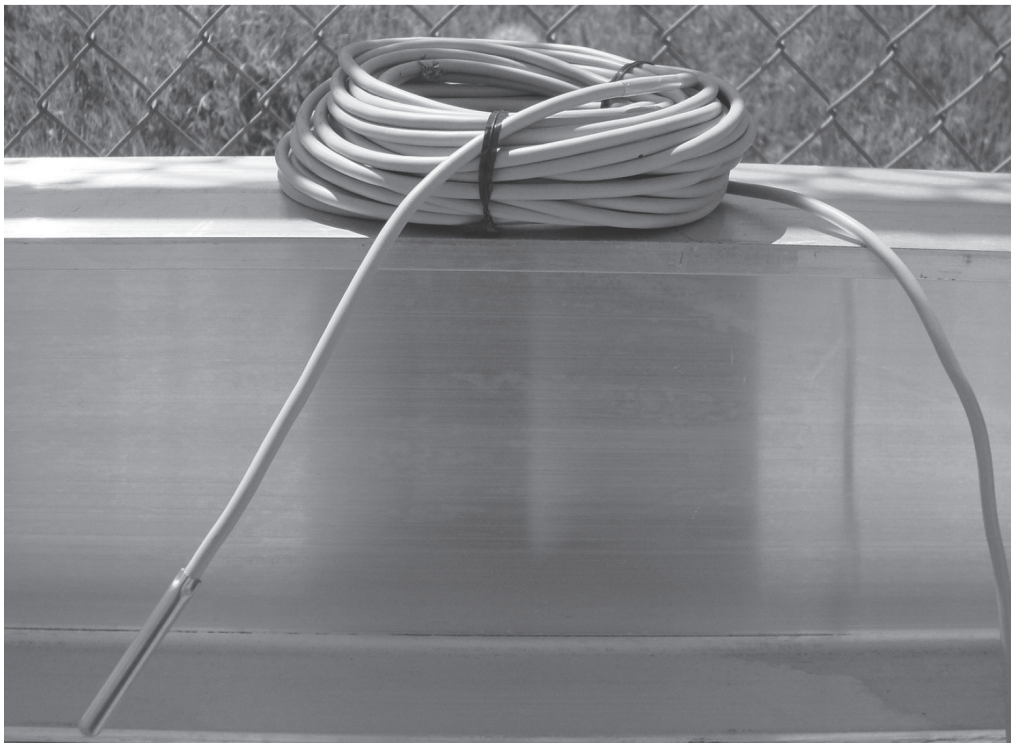

2.2.3 **This is not intended as a high-output defroster.** If the system is left off during prolonged periods of snow and ice accumulation, it will likely take MANY HOURS of operation to thaw the system.

2.2.4 The conductors are covered with medium heat cover (Lexan good to 250°F) as a precaution against the unlikely event of the heater wire making contact with the inside of the conductor cover. The systems are designed to have an output of 4.5-7.6 Watts per Foot (15-25 Watts per Meter).

2.2.5 **NOTE:** The NEC does not allow the powering of the heater wire system from the conductor bar. It must be fed and protected by a separate circuit.

2.0 SYSTEM OVERVIEW



2.3 Thermostatic Control Box

2.3.1 The control box consists of a temperature and power module, transformer, contactor, and fuse blocks. There are three field connections to be made to install this:

1. XA-564034 Control Box
 - a. 240/600V Thermo Control
 - b. 10A - 60A configurations
2. Temperature sensor to ambient air
3. Power output wires running to the feed junction points (L1, L2, L3)

2.4 Cold Wire Connections

2.4.1 The cold wire connections are used to bring power from the control box to the heater wire. Additionally, there are cold wire connections (end loop connections, page 21) to jumper adjacent heater wire run together to achieve the desired configuration.

2.4.2 **NOTE:** Heater wire feeds can be located with an end powerfeed in the system. However, heater wire feeds must have a dedicated feed point on all center fed systems.

2.5 Requirements for Determining System:

2.5.1 To determine a system you need to know:

1. Input Voltage
2. Number of Conductors
3. Length of System.

3.0 INSTALLATION & ASSEMBLY

3.1 General Assembly Instructions

WARNING: ALWAYS LOCK OUT/TAG OUT ALL ELECTRICAL POWER BEFORE STARTING WORK.

3.1.1 This manual provides detailed instructions in the general order of system installation.

3.1.2 System installation consists of 5 phases:

3.1.2.1. Identifying and organizing the materials. Check the pack list against the items received. Parts are labeled for your convenience. Review your specific installation layout drawing (if provided), the typical layout diagram provided at the back of this manual, or the Quick Quote layout to become familiar with component location on the system. Note where the anchors, expansions, power feeds, and other assemblies will be located along the runway. Read through these instructions before starting work.

Do not remove shipping support from expansion sections or power interrupting sections until they have been installed on the runway.

3.1.2.2. Installation of brackets along the runway. Keep them as level and evenly spaced as possible. You may install the hangers on the brackets before or after they are mounted along the runway.

3.1.2.3. Pre-install assemblies on the ground. It's faster, easier, safer and more convenient should you drop something. Conductor Bar and Expansion Sections will come from the factory with one splice pre-installed.

3.1.2.4. Installation of hangers and conductors and final assembly along the runway. This will most likely be accomplished from a lift or work platform.

- a. Ensure the power is locked out/tagged out!
- b. Install the hangers, per instructions on page 12. Ensure correct alignment and location of support brackets.
- c. Roll conductors into the hangers.
- d. Conductix recommends the first accessible conductor being the ground conductor (if applicable).
- e. Move down the runway, install the next inboard conductor and join it to the corresponding conductor installed in step 4c. Ensure all electrical joints are free from any contamination on Galvanized or Copper conductors. Clean and apply Electrical Joint Compound (EJC) to Aluminum/Stainless Steel conductors. Install the splice cover. Keep the splice assemblies at least 8.0" (203mm) from the hanger brackets to allow for conductor movement from expansion and contraction. Repeat for the remaining phases and ground conductors.
- f. When you get to where the expansion assemblies are to be installed, refer to the instructions on page 15. Be sure to divide the total expansion gap distance (from chart) between the two air gap locations in the expansion assembly. (If the total gap setting = 1.85" (47mm), each air gap will be 0.93" (23.5mm). Ensure the expansion assembly body is at least 8.0" (203mm) from the nearest bracket.
- g. Proceed with system installation ensuring anchors are positioned the correct distance from the expansions and that they are tightened.
- h. If a conductor must be cut to a specific length, ensure that the cut end is properly de-burred. The conductor cover is always shorter than the bar length. The proper cover length is 2.60" (66mm) shorter than bar length 1.30" (33mm) on each end.
- i. When running the feed cable to the power feed assembly, ensure the cables have sufficient free length and are flexible enough to enable movement of the conductor due to expansion and contraction. Locating the power feed as close as possible to the anchors minimizes this concern. DO NOT support the weight of the feed cables with the conductors.
- j. Install power feeds on conductor bars per layout and the instructions beginning on page 16.
- k. Ensure all armored cables are terminated into a suitable junction box and only flexible cables are installed into the power feed assemblies.

***NOTE: ALL HEATER WIRE WILL BE FED AT A SPLICE, OR AN END POWER FEED. THE HEATER WIRE SYSTEM WILL BE LABELED WITH A POWER FEED LOCATION ON THE SYSTEM LAYOUT.**

3.1.2.5 Installation and alignment of collectors on the crane. Collectors must be properly positioned and aligned to ensure safe, reliable operation. Collector arms should be parallel with the contact surface.

- a. The collector mounting post must be 5.0" (127mm) for 200 Amp collectors, 4.0" (102mm) for 100 Amp DI collectors, and 3.5" (90mm) for 50 Amp SI collectors, below the contact surface of the conductor and the arms level from end to end.
- b. Slide the collectors on the mounting staff. Ensure the mounting base of each collector is centered below the corresponding conductor. Ensure the collectors are evenly spaced. Tighten hardware to specifications and connect the supply cable to the collector per diagram on page 29.

3.0 INSTALLATION & ASSEMBLY

3.1.3 REMEMBER

1. Follow lock out/tag out procedures.
2. Keep accessories at least 8" (203mm) from hanger brackets.
3. Follow all torque specifications.
4. Allow for movement of accessories due to expansion.
5. Connect only flexible power cables to power feed assemblies.
6. Keep collectors straight, level and aligned with conductors.

3.2 Support Bracket Installation

3.2.1 Flange Bracket Installation

3.2.2 Locate and secure support brackets at the recommended spacing. (Note: Locate support brackets at a spacing that is divisible into the conductor bar lengths. This will always ensure that the joint positions do not interfere with the support brackets). Maximum bracket spacing to be 59.05" (1.5M).

3.2.3 Observe all alignment tolerances. Datum height. Maximum allowable deviation from datum height +3/16" (+5.0mm).

FOR CONDUCTIX BRACKETS: Hanger support brackets come complete with all necessary mounting holes for easy installation of hangers via slide in slots or holes.

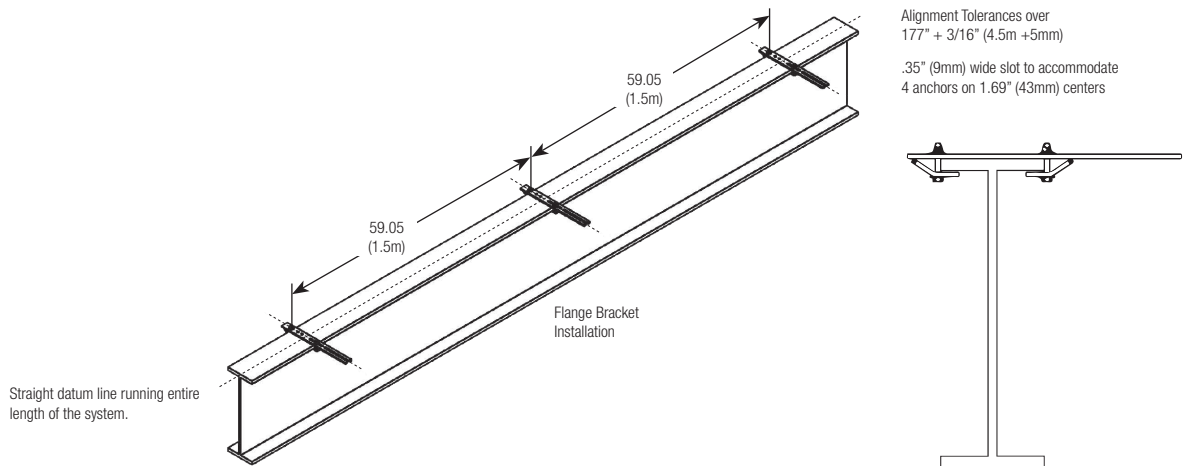

3.3 Web Bracket Installation

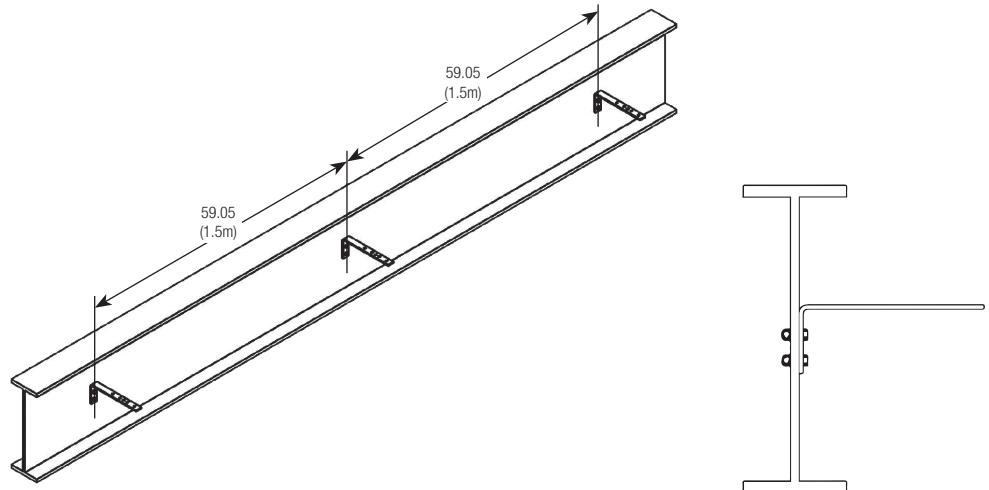

3.0 INSTALLATION & ASSEMBLY

3.4 Mounting Details of Conductor Hanger

NOTE: for lateral mount, consult factory.

3.3.1 Remove nut, lock washer, and washer from hanger assembly.

3.3.2 Assemble as shown in the diagram ensuring the correct alignment is observed.

3.3.3 Finger tighten nut.

3.3.4 Snap conductor bars into hangers.

3.3.5 Tighten nut to Conductix recommended torque of 5-6 FT-LBS (8 Nm).

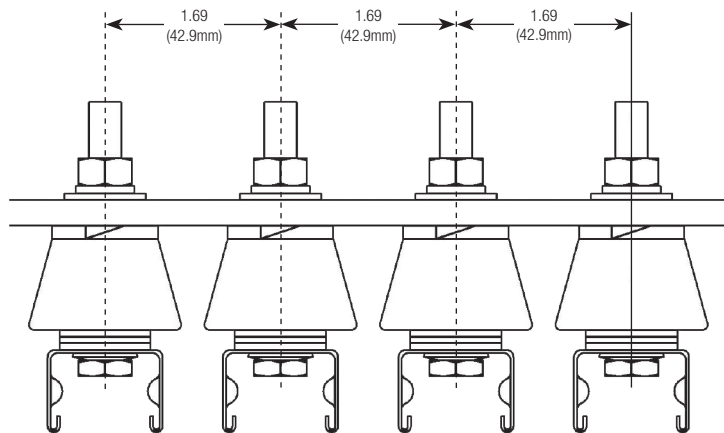

NOTE: Stainless steel hangers should be used with the appropriate insulators to avoid any shorting to ground.

3.4 Installing Conductors into Hanger

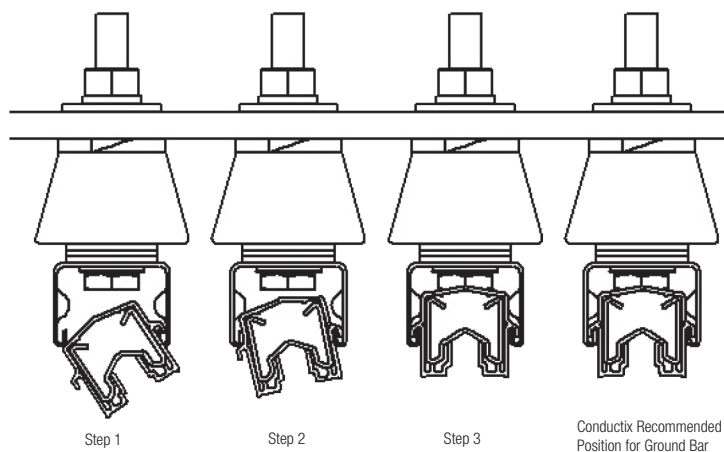

3.0 INSTALLATION & ASSEMBLY

3.5 Hanger types

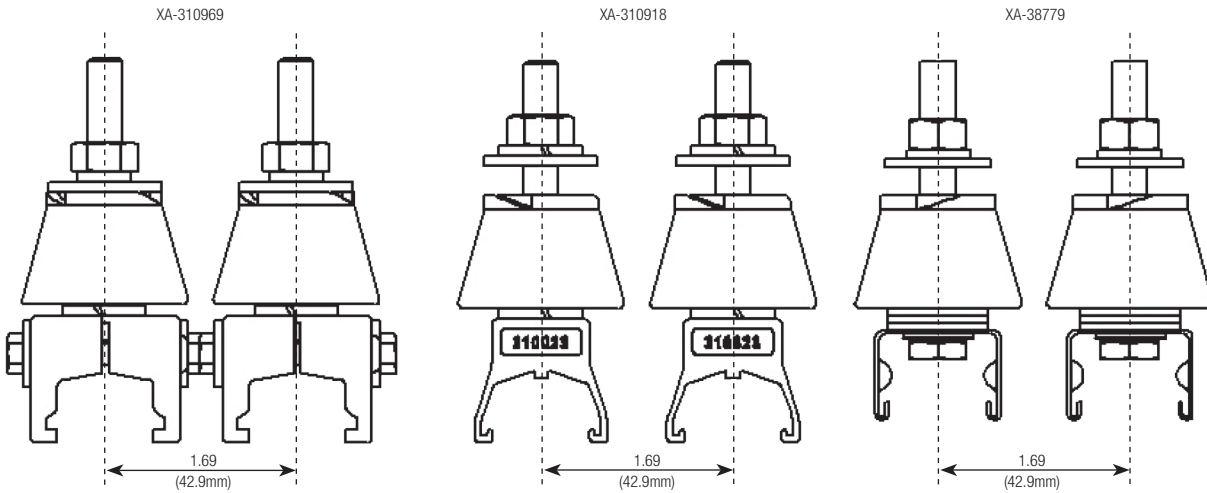

3.6 Anchor Hanger Support Assembly Installation

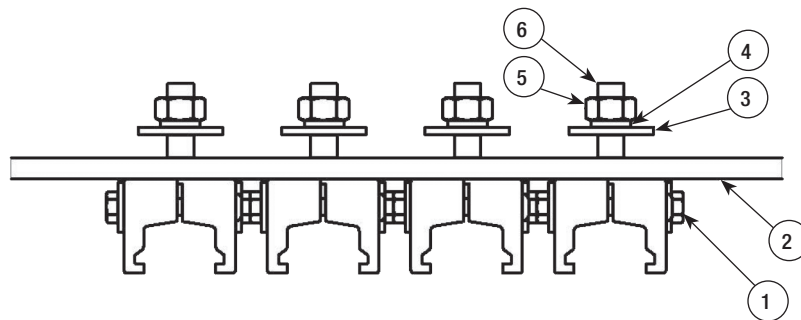

3.6.1 **Note:** For ease of access to clamping set screws, item 1, install anchor assemblies from back to front or left to right as shown above.

3.6.2 **Tools required:** 13mm open ended wrench, 8mm open ended wrench

1. Remove items 3, 4 and 5 from assembly.
2. Assemble anchor over cover so this is free to slide.
3. Insert anchor hanger into support bracket.
4. Reassemble items 3, 4 and 5.
5. Tighten item 1 until anchor stops meet. (Check anchor is tight on cover).
6. Tighten item 5 to a torque of 5-6 FT-LBS (8 Nm).
7. Repeat steps 1 through 6 on the remaining three anchors.

3.0 INSTALLATION & ASSEMBLY

3.7 Assembly of Bolted Joint

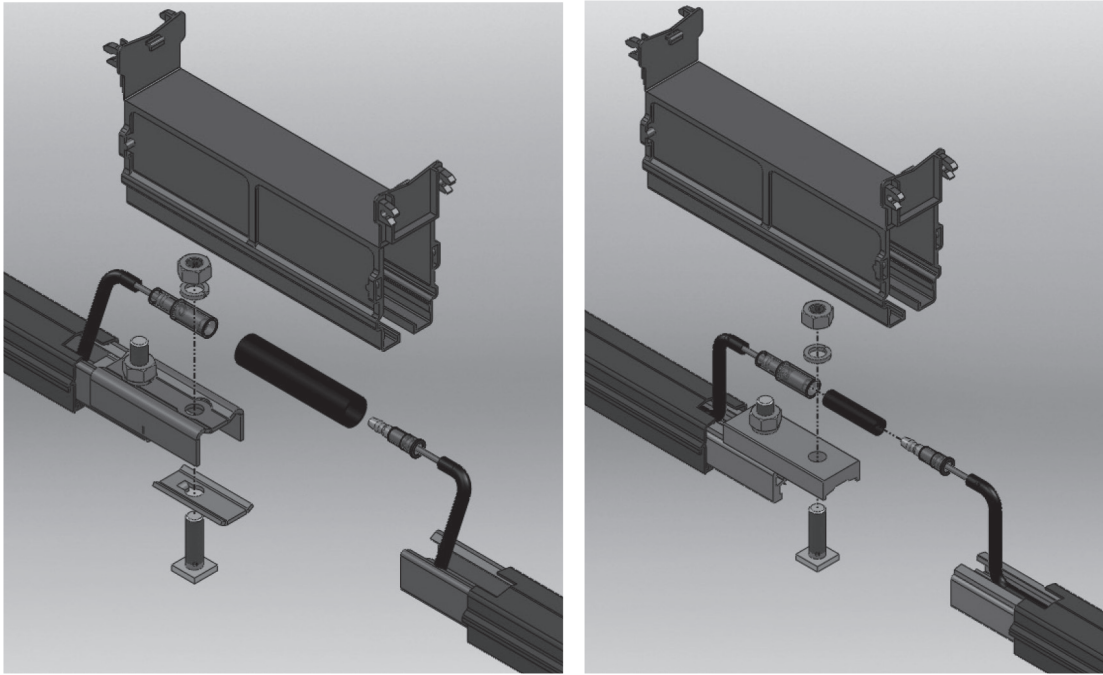

3.7.1 **Tools required:** 10mm open ended wrench, Scotch Brite pad, Electrical Joint Compound (EJC), heat gun

1. For Aluminum/Stainless Steel only, use Scotch Brite pad and apply EJC to the joining faces of the conductor bars.
2. Slide bolts into conductor bars.
3. Place splice plate over bolts.
4. Place lock washers and nuts onto the bolts. Tighten to a Conductix recommended torque of 5-6 FT-LBS (8 Nm).
5. Check that both faces of conductor bar are touching each other and that there is no gap exceeding 0.02" (0.5mm) at the faces.
6. Spring legs of joint cover out as to ease the fitting of the joint cover over the conductor bar.
7. Fit the joint cover over the bolted joint. Joint cover **MUST NOT** be opened more than 45° on either side during the assembly over the joint. Ensure the location section inside the joint cover sits between the two bolts.
8. Close the flaps ensuring they "click" home on both sides.

3.7.2 **Note:** If the conductor was field cut, file off all burrs on conductor ends before assembling splices. Exposed length of bar should be 1.30" (33mm).

3.0 INSTALLATION & ASSEMBLY

3.8 Assembly of Expansion Section

- 3.8.1 **Locations:** The maximum allowable conductor system length without an expansion section is 492' (150m), assuming a maximum temperature range of 110°F (43.5°C).
- 3.8.2 The maximum distance between anchor points with an expansion section at midpoint is: 230' (70m) for Steel, 160' (49m) for Copper, and 120' (36.5m) for Aluminum.
- 3.8.3 Set expansion air gaps when installing assembly to appropriate gap setting for ambient temperature (see chart). The gap is adjusted by sliding the moving lengths of conductor in or out of the expansion assembly (Note: BOTH HALVES MUST BE SET EQUAL). Always allow sufficient time for the conductor bars to achieve ambient temperature before setting expansion gap. All expansion assemblies must be set at site, they are not pre-set before leaving the factory. Failure to set this part correctly could result in buckling of all conductors.

Table T-1							
Gap Setting		Temperature Chart					
		Chart 1		Chart 2		Chart 3	
Inches	mm	°F	°C	°F	°C	°F	°C
2.00	50.8	120	48.9	110	43.3	100	37.8
2.16	54.9	115	46.1	105	40.6	95	35.0
2.33	59.2	110	43.3	100	37.8	90	32.2
2.50	63.5	105	40.6	95	35.0	85	29.4
2.66	67.6	100	37.8	90	32.2	80	26.7
2.83	71.9	95	35.0	85	29.4	75	23.9
3.00	76.2	90	32.2	80	26.7	70	21.1
3.16	80.3	85	29.4	75	23.9	65	18.3
3.33	84.6	80	26.7	70	21.1	60	15.6
3.50	88.9	75	23.9	65	18.3	55	12.8
3.66	93.0	70	21.1	60	15.6	50	10.0
3.83	97.3	65	18.3	55	12.8	45	7.2
4.00	101.6	60	15.6	50	10.0	40	4.4
4.16	105.7	55	12.8	45	7.2	35	1.7
4.33	110.0	50	10.0	40	4.4	30	-1.1
4.50	114.3	45	7.2	35	1.7	25	-3.9
4.66	118.4	40	4.4	30	-1.1	20	-6.7
4.83	122.7	35	1.7	25	-3.9	15	-9.4
5.00	127.0	30	-1.1	20	-6.7	10	-12.2
5.16	131.1	25	-3.9	15	-9.4	5	-15.0
5.33	135.4	20	-6.7	10	-12.2	0	-17.8
5.50	139.7	15	-9.4	5	-15.0	-5	-20.6
5.66	143.8	10	-12.2	0	-17.8	-10	-23.3
5.83	148.1	5	-15.0	-5	-20.6	-15	-26.1
6.00	152.4	0	-17.8	-10	-23.3	-20	-28.9

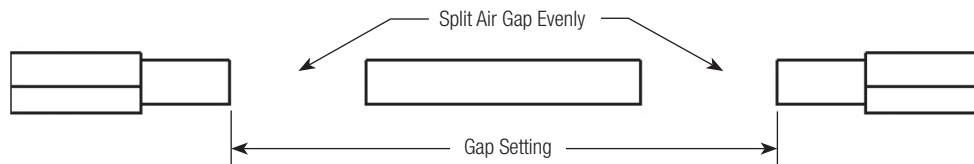

3.0 INSTALLATION & ASSEMBLY

3.9 Assembly of end Power Feed (100 Amp Conductor Bar Only)

P/N XA-310911

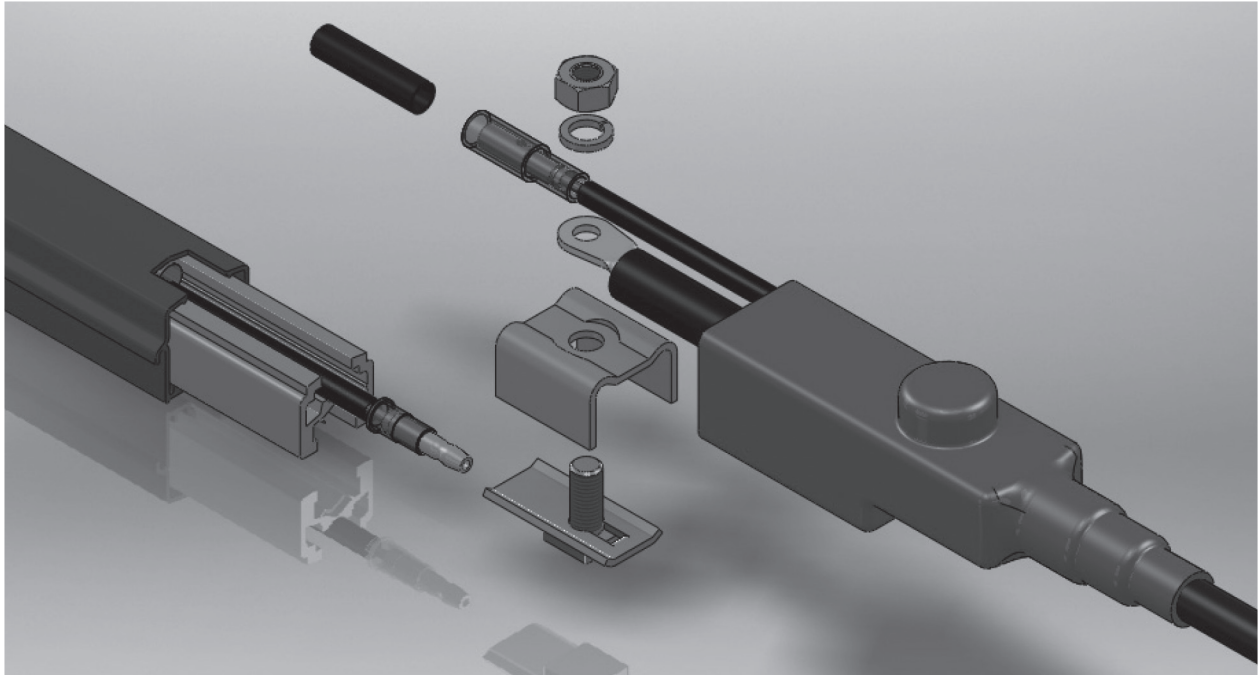

3.9.1 **Tools Required:** 10mm wrench, suitable sharp knife, cable stripper, cable crimping tool, suitable cable terminal.

1. Cut end power feed cover to suit cable diameter.
2. Pass power cable and heater wire cable through power feed cover.
3. Crimp terminal to cable.
4. Place bolt and joint plate into conductor bar. Note: tab to face downward.
5. Fit end cover clamp over items bolt/joint plate assembly.
6. Fit terminal and secure with washer and nut.
7. Tighten nut to Conductix recommended torque of 56 FT-LBS (8 Nm).
8. Assemble heat shrinkable tubing over male bullet.
9. Insert male bullet into female bullet and ensure that it snaps fully home.
10. Position heat shrinkable tubing, centrally, over bullet assembly and gently heat until bullet assembly is encapsulated. Do not overheat tubing.
11. Push end power feed cover over assembly. (Ensure bolt is located in the "hat" of the cover).

3.9.2 **Max cable size:** #4 AWG Extra Flexible (25 sq. mm PVC 600/100V stranded copper conductor).

3.0 INSTALLATION & ASSEMBLY

3.10 Assembly of Joint Power Feed (up to and including 250 Amp)

P/N XA-310913

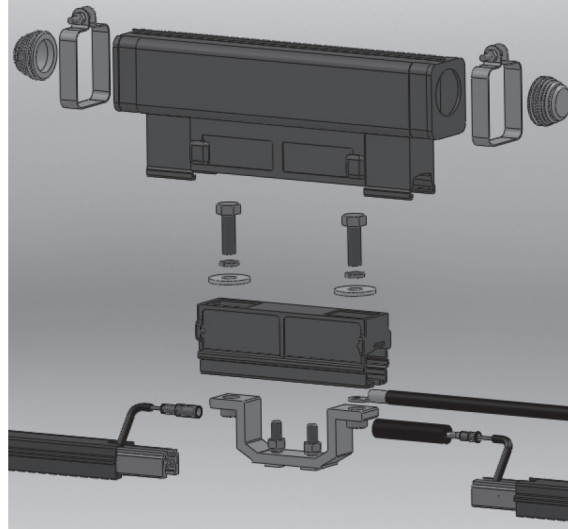

3.10.1 **Tools Required:** 10mm wrench, suitable sharp knife, cable stripper, cable crimping tool, suitable cable terminal.

1. Assemble joint to conductor bar as described previously in the manual.
2. Fit aluminum hat section to joint assembly. (On copper and aluminum conductors, use Scotch Brite and apply EJC between mating surfaces).
3. Discard spring washers originally fitted to the joint assembly and fit external tooth lock washers (supplied in the kit), along with nuts and tighten to a Conductix recommended torque of 5-6 FT-LBS (8 Nm).
4. Fit joint power feed cover as shown previously in the manual.
5. Cut out grommet using suitable knife and fit over cable.
6. Crimp terminal to supply cable. Ensure the terminal is properly crimped as failure to do so will result in over-heating on the power feed assembly.
7. Fit terminal to the hat channel and secure using hardware. Torque to 5-6 FT-LBS (8 Nm).
8. Hardware on the opposite side is for use with two cable feeds and should be left tight on the hat channel if only one feed is used.
9. Fit power feed cover to assembly.
10. Ensure both grommets are fitted into the power feed cover before closing halves together.
11. Make sure the legs of the cover fit under the conductor cover support ears. (A little pressure at the top of the power feed cover will ensure this).
12. Fit case clips to the power feed case and secure with screws.

3.0 INSTALLATION & ASSEMBLY

3.11 Assembly of Joint Power Feed (over 250 Amp)

P/N XA-310915

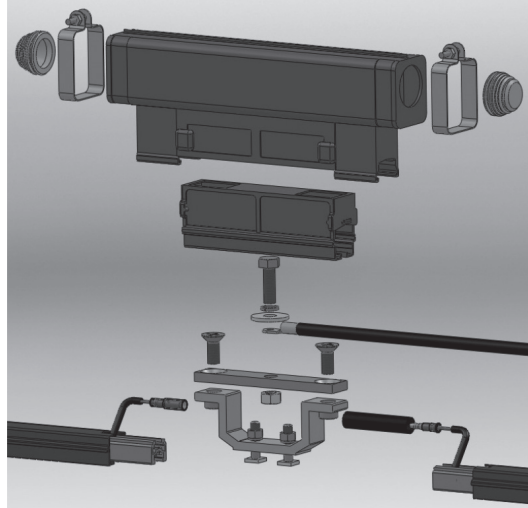

3.11.1 **Tools Required:** 10mm wrench, suitable sharp knife, cable stripper, cable crimping tool, suitable cable terminal.

1. Assemble joint to conductor bar as described previously in the manual.
2. Fit aluminum hat section to joint assembly. (On copper and aluminum conductors, use Scotch Brite and apply EJC between mating surfaces).
3. Discard spring washers originally fitted to the joint assembly and fit external tooth lock washers (supplied in the kit), along with nuts and tighten to a Conductix recommended torque of 5-6 FT-LBS (8 Nm).
4. Fit joint power feed cover as shown previously in the manual.
5. Use Scotch Brite and apply EJC between mating surfaces on the hat channel and power feed shunt.
6. Place power feed shunt over hat channel and secure with screws. Torque to 8 Nm (5-6 FT-LBS).
7. Cut out grommet using suitable knife and fit over cable.
8. Crimp terminal to supply cable. Ensure the terminal is properly crimped as failure to do so will result in over-heating on the power feed assembly.
9. Apply EJC to the center arc of power feed shunt.
10. Fit lug to the center of power feed shunt and secure with hardware as shown. Torque to 5-6 FT-LBS (8 Nm).
11. Fit power feed cover to assembly.
12. Ensure both grommets are fitted into the power feed cover before closing halves together.
13. Make sure the legs of the cover fit under the conductor cover support ears. (A little pressure at the top of the power feed cover will ensure this).
14. Fit case clips to the power feed case and secure with screws.

3.0 INSTALLATION & ASSEMBLY

3.12 Assembly of Heater Center Power Feed

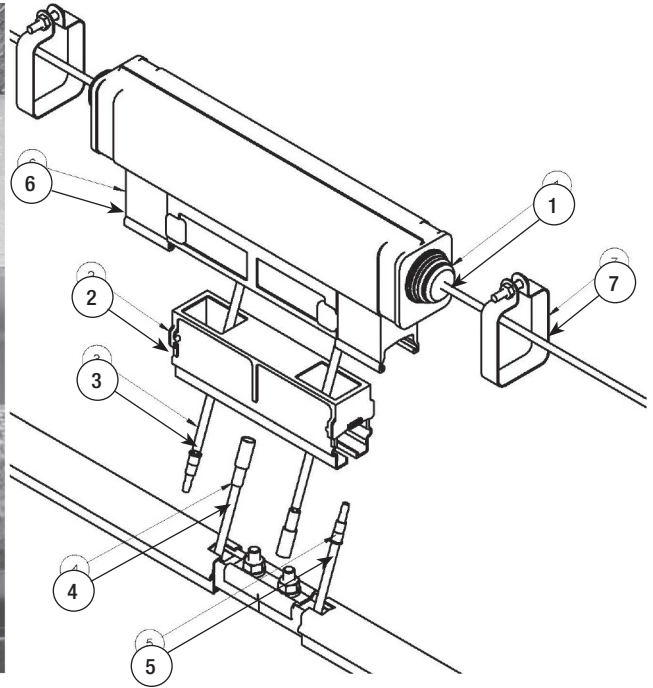
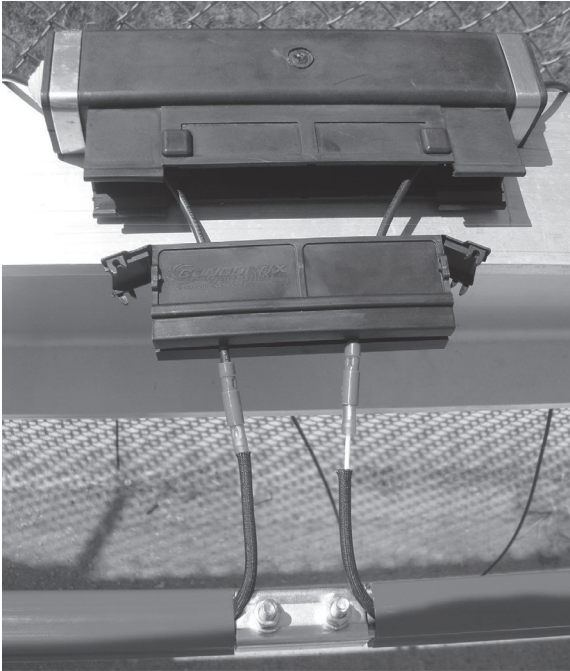

3.12.1 Tools Required: Heat gun, 10mm wrench.

1. Assemble joints in normal manner, but do not connect heater wires.
2. Pass supply leads through grommets, item 1, and through holes in joint cover, item 2.
3. Assemble heat shrinkable tubing over male bullet connectors, item 5, and insert male bullets into female bullets. Ensure that they snap fully home.
4. Gently heat tubing until it encapsulates bullet assembly.
5. Repeat steps 4 and 5 for the second heater wire.
6. Assemble joint covers over joint in the normal manner.
7. Assemble power feed cover, item 6, over the joint.
8. Assemble the clips, item 7.

3.0 INSTALLATION & ASSEMBLY

3.13 Connection of End Loop

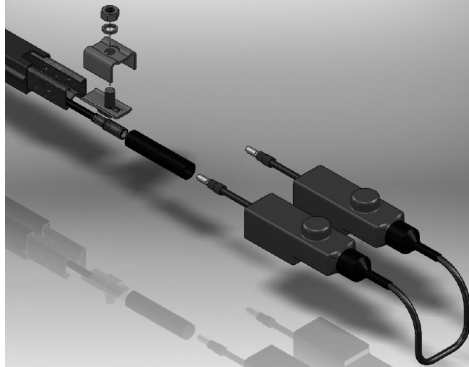

3.13.1 **Tools required:** Heat gun, 10mm wrench.

1. Assemble heat shrinkable tubing over male bullet.
2. Insert male bullet into female bullet ensuring that it snaps fully home.
3. Position heat shrinkable tubing centrally over bullet assembly and gently heat until it has encapsulated bullet assembly. Do not overheat tubing.
4. Repeat the above for each conductor bar (refer to the diagram selected for this system).

3.0 INSTALLATION & ASSEMBLY

3.14 Mounting Details for 50 Amp SI Collector

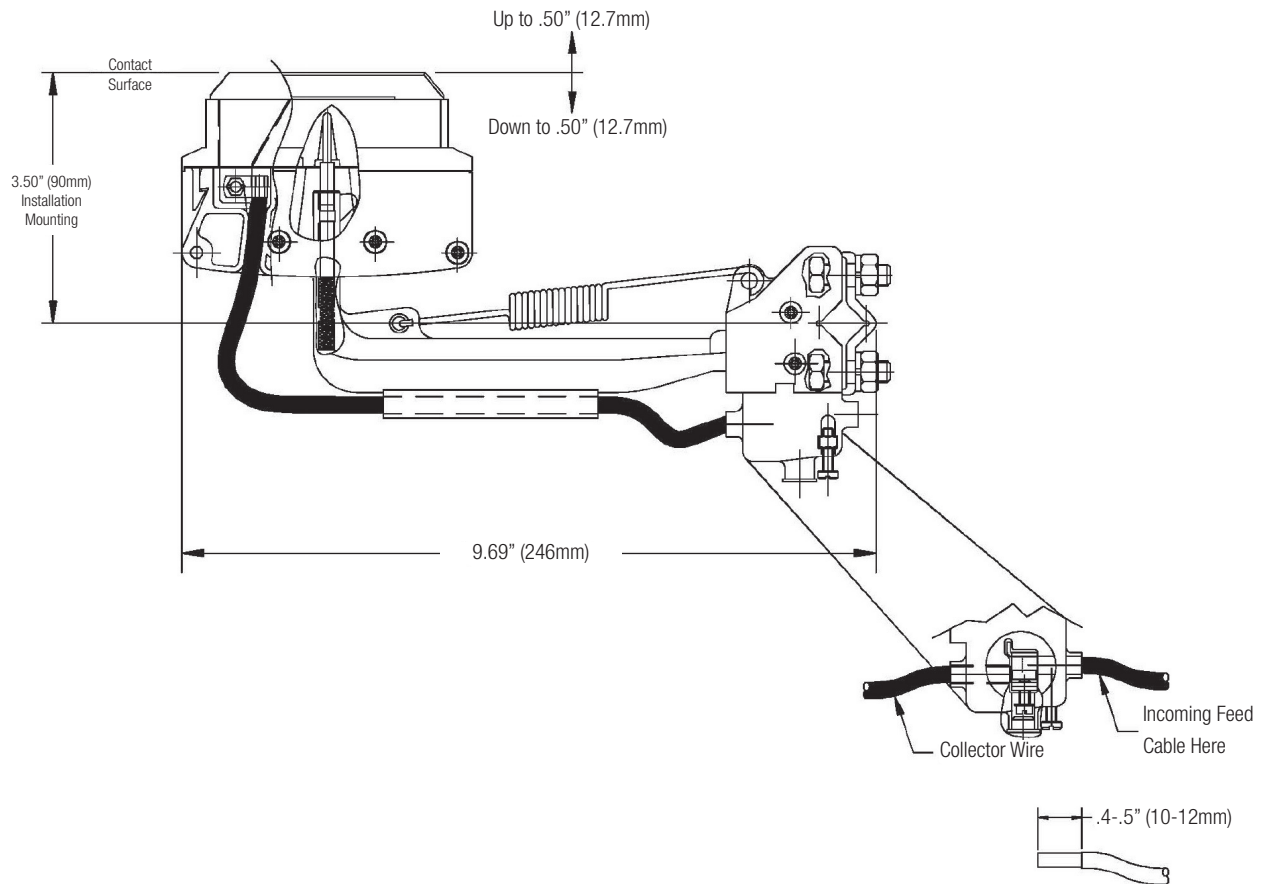

XA-399360 (Red) & XA-399380 (Green)

3.14.1 This collector is rated for 25 Amps continuous in a stationary position on copper and galvanized steel. It is rated for 12 Amps on Aluminum/Stainless for the same condition.

3.14.2 **Tools Required:** 13mm wrench, steel rule or suitable tape measure, flat bladed screwdriver, cable stripper.

1. Fix collector mounting bracket to a suitable support at the correct setting height (see diagram).
2. Place collector on the mounting bracket.
3. Tighten nuts to a Conductix recommended torque of 8-10 FT-LBS (11 Nm).

3.0 INSTALLATION & ASSEMBLY

3.15 Mounting Details for 100 Amp DI Collector

XA-310990 (Red) & XA-399355 (Green)

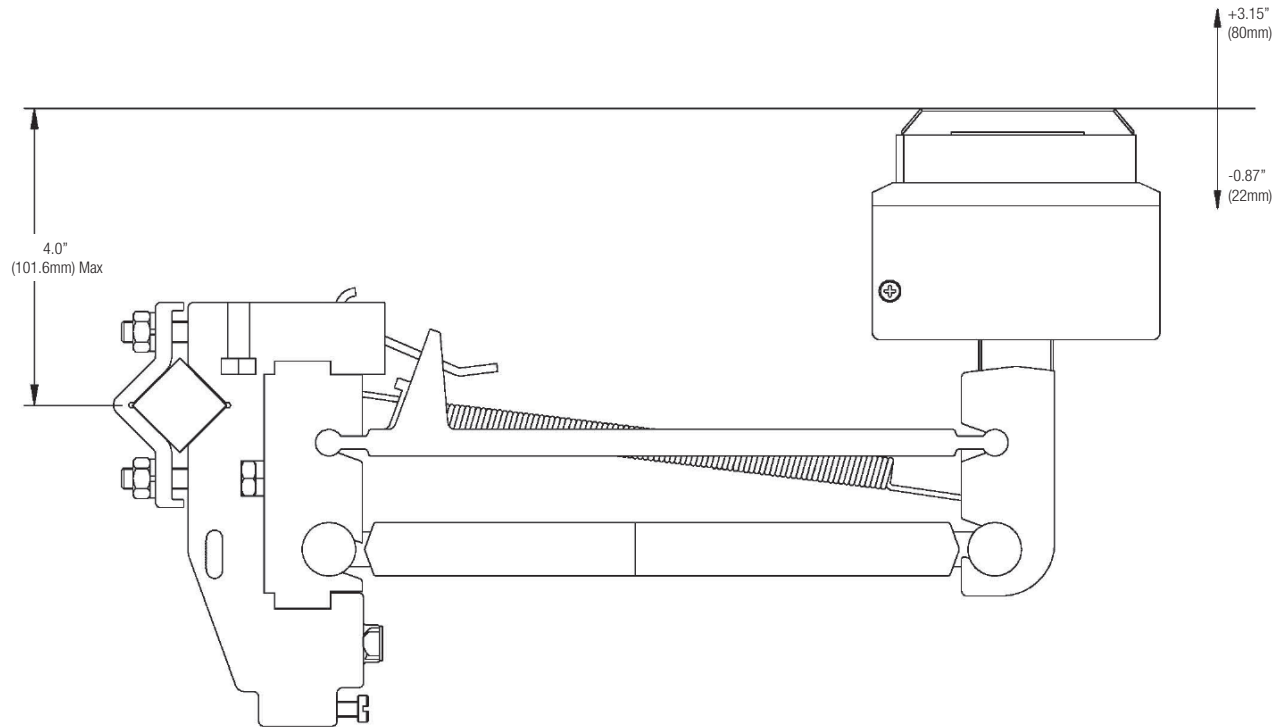

3.15.1 This collector is rated at 50 Amps continuously in a stationary position on copper and galvanized steel. It is rated for 25 Amps on Aluminum/Stainless for the same condition.

3.15.2 **Tools Required:** 13mm wrench, steel rule or suitable tape measure, flat bladed screwdriver, cable stripper.

1. Fix collector mounting bracket to a suitable support at the correct setting height (see diagram).
2. Place collector on the mounting bracket.
3. Tighten nuts to a Conductix recommended torque of 8-10 FT-LBS (11 Nm).

3.15.3 Customer Supplied Cable Installation

1. Strip customer supplied cable back 0.5-0.6" (13-15mm), using a suitable cable stripping tool.
2. Remove protection plug from the hole and loosen screw.
3. Loosen screw below plug until clear from entry hole.
4. Push customer supply cable into entry hole.
5. Tighten screw fully and ensure that the cable is clamped firmly into position.
6. Tighten cable clamp screw.
7. Replace protection plug.

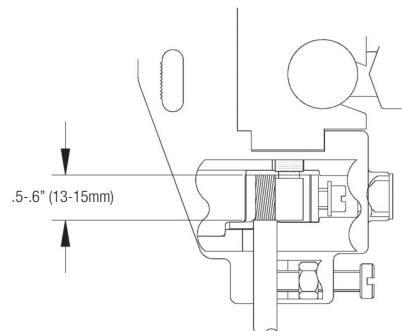

3.0 INSTALLATION & ASSEMBLY

3.16 Mounting Details for 200 Amp Collector

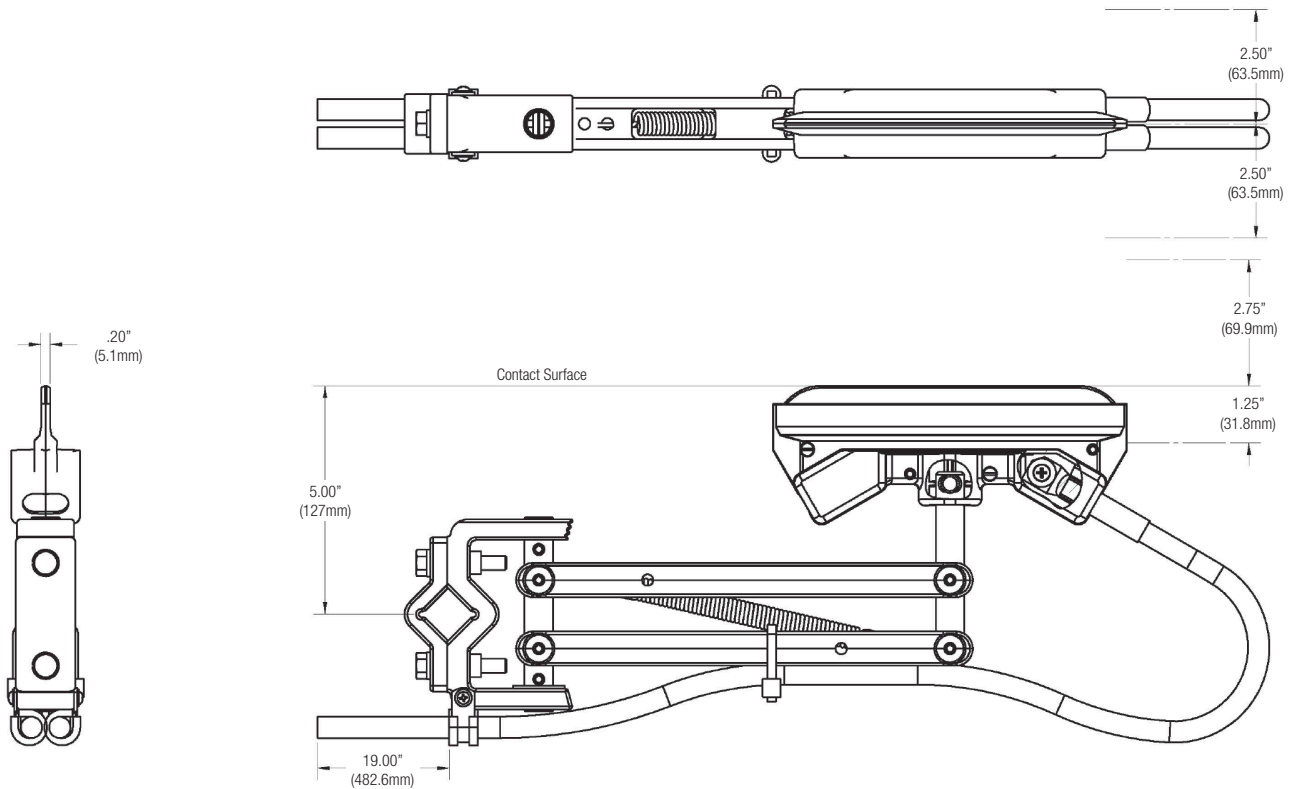

3.16.1 Torque mounting hardware to 10-12 FT-LBS (15 Nm).

3.16.2 **Note:** This collector is UL rated at 100 Amps continuous duty in a stationary position on copper and galvanized steel. It is rated at 50 Amps on Aluminum/Stainless for the same condition.

3.0 INSTALLATION & ASSEMBLY

3.17 Replacement of DI & SI Collector Contact Shoe and Shoe Holder

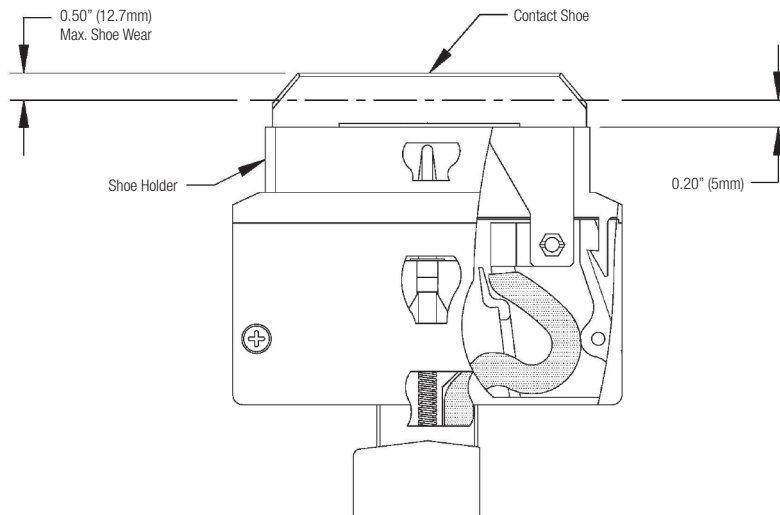

3.17.1 **Note:** Collector contact shoe and shoe holder are supplied as replacement part number XA-310993, ground conductor part number XA-399357. (For ground shoes with deflector, consult factory).

3.17.2 **Tools Required:** Flat blade screwdriver, 7mm wrench

1. Lever lugs in direction shown.
2. Lift shoe and holder.
3. Disconnect cable.
4. Reverse procedure to install new shoe.

3.18 Replacement of 200 Amp Collector Contact Shoe

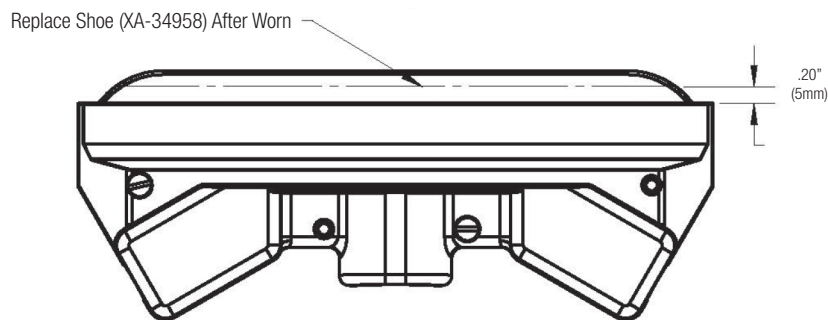

4.0 MAINTENANCE

4.1 Inspection & Maintenance Background

4.1.1 Proper system performance and reliability require thorough periodic system maintenance. Each component of the system must be inspected, as a minimum, annually. Many components require more frequent inspection and possibly maintenance. Bolt torque, cable connection integrity, insulating material integrity, and collector alignment and shoe wear among the primary areas of concern.

WARNING: ALL POWER MUST BE DISCONNECTED FROM THE GUIDEWAY PRIOR TO PERFORMING ANY INSPECTION OR MAINTENANCE. PROPER LOCK OUT/TAG OUT PROCEDURES MUST BE FOLLOWED.

Should questions or concerns arise regarding the condition of the system or its components, call Conductix Corporation at (800) 521-4888.

4.2 Inspection & Maintenance Frequency:

Component	Frequency	Component	Frequency
Covers	Semi-Annually	Hanger Clamps	Semi-Annually
Conductor	Semi-Annually	Splice	Semi-Annually
Anchor	Semi-Annually	Expansion	Semi Annually
Power Feed	Semi-Annually	End Cap	Semi-Annually
Collector Assemblies	Quarterly		

4.3 Inspection & Maintenance of Covers:

4.3.1 All covers (conductor and component overlap covers) shall be inspected semi-annually.

4.3.2 The integrity of the cover is critical. Damage to the cover in the form of cracks, splits, or holes requires replacement.

4.3.3 Inspect the visible outside surfaces of the conductor and overlap covers for signs of damage. Replace as necessary.

4.4 Inspection & Maintenance of Hanger Clamps:

4.4.1 Check the hanger clamps to ensure there are no cracks or fractures in the molded plastic clamps. Replace components as necessary.

4.4.2 Check bolt torque per drawing. This can be a random sampling of 2 hanger clamps between each set of anchors, see chart.

Maximum Distance between Anchor Points	
Aluminum Bars	120' (36.5m)
Steel Bars	230' (70m)
Copper Bars	160' (49m)

If the hardware is not at a minimum of 15 FT-LBS, all the hardware between those two anchors must be checked and/or properly torqued.

4.5 Inspection & Maintenance of Conductor:

4.5.1 All conductors shall be inspected semi-annually.

4.5.2 Inspect the contact surfaces and open area inside the cover for any debris and abnormal wear in 150' (45.7m) intervals. This will give a good overall indication of the degree of debris accumulations throughout the system.

4.0 MAINTENANCE

4.6 Inspection & Maintenance of Splice:

- 4.6.1 Remove covers and check bolt torque.
- 4.6.2 If bolts are loose, remove the splice plate and check for signs of burning or arcing between the conductor and splice plate. Replace damaged components as required following the installation instructions. Apply conductive grease when reinstalling splices.
- 4.6.3 Check overlap covers and end caps for signs of damage. Replace as required.

4.7 Inspection & Maintenance of Anchor Clamps:

- 4.7.1 Check the anchor clamps to ensure there are no cracks or fractures in the molded plastic clamps or damage to the stainless steel hangers. Replace components as necessary.
- 4.7.2 The anchor mounting nut should be torqued to 5-6 FT-LBS (7Nm)

4.8 Inspection & Maintenance of Expansion:

- 4.8.1 All expansions shall be inspected semi-annually.
- 4.8.2 Inspect the contact surfaces and open area inside the cover for any debris and abnormal wear. Verify there are no obstructions in the slots that will inhibit movement. Grab the block and determine if it is loose. Look for evidence of shoes hitting block. This could indicate that the block has come loose and will make shoes jump out of contact with conductor. The slider may have to be replaced.

4.9 Inspection & Maintenance of Power Feed:

- 4.9.1 Remove covers and check bolt torque. If bolts are loose, remove the splice plate and check for signs of burning or arcing between the conductor and splice plate. Replace damaged components as required following the installation instructions. Apply conductive grease when reinstalling splices. **Check overlap covers and end caps for signs of damage. Replace as required. Check to ensure the grommets are located securely in the end plugs. Check cable for abrasion or damage to the jackets. Replace as required.**

4.10 Inspection & Maintenance of End Cap:

- 4.10.1 Inspect the cover on the end cap for damage in the form of cracks, splits, or holes. Replace as necessary.

4.11 Inspection & Maintenance of Collector:

- 4.11.1 Inspect quarterly for signs of cracks, wear, damage, dirt accumulation, or anything that would indicate an item, or the assembly, needs to be replaced. At a minimum, the inspection should include:
- 4.11.2 **Collector Arms:** Inspect for cracks, deformation, or any other evidence of damage. Check the collector pivot points are free from any contamination. Collector arm should be replaced at least every 5 years.
- 4.11.3 **Mounting Bracket & Bolts:** Collector mounting base is square on the vehicle and it is aligned with the conductor.
- 4.11.4 **Tension spring:** Spring is properly positioned on the pin in the base. Contact force and nominal distance between the mounting surface and contact surface. (Contact Conductix for force requirement)A "fish scale" may be used to check. Hook the scale on the collector arm as close to the shoe-end of the collector. Pull the scale. The contact force is the force at which the arm begins moving away from the conductor. Replace if spring tension is not correct.
- 4.11.5 **Spring Pins:** Inspect for cracks, deformation, or any other evidence of damage. Verify all are in place.

4.0 MAINTENANCE

- 4.11.6 **Cables:** Cable length between lug on shoe and cable clamp on arm is per the drawing. Cable routing to vehicle must allow free movement of collector throughout its complete range of motion. Check that cables are properly terminated to the vehicle (specification by others).
- 4.11.7 Inspect the cables weekly for damage or abrasions. Ensure the electrical connections are solid and the bolted connections at the lugs are tight.
- 4.11.8 Shoe Holder: Inspect for cracks, deformation, or any other evidence of damage.
- 4.11.8.1 All retaining rings and E-rings are securely in place.
- 4.11.8.2 Inspect the shoes weekly for wear and damage. Replace the shoes when the height, measured at any location along the shoe, is 3/16" or less.
- 4.11.8.3 If a broken shoe is found, inspect the system for the cause. Broken shoes usually result from:
- Insufficient contact force causing the shoe to bounce excessively. Replace the spring as required.
 - Gaps at a splice joint. Loosen splice hardware and butt conductors. Tighten fasteners and re-torque.
 - Misalignment between adjacent conductors. Realign as required.
 - Misalignment between the vehicle and guideway pulling the collector beyond its maximum horizontal and/or vertical envelope. This usually happens around curves in the guideway or in locations where hanger clamps and/or mounting brackets are not properly aligned. Realign as necessary. The base of the collector should be directly in line with its associated conductor.
 - Inspect the shoes for uneven wear on a monthly basis until a wear pattern can be established. Uneven wear can be an indication of insufficient contact force or bias on a shoe due to cable routing, incorrect location of the tension spring, or misalignment. Uneven shoe wear, if not corrected, can wear the side of the aluminum bar resulting in the stainless steel contact surface coming loose. Both ends of the shoe must be checked for uneven wear.

4.12 Collector Shoe Replacement:

- 4.12.1 Due to a wide variety of applications and environmental conditions, no time frame is given for shoe replacement. It is recommended, however, that the customer do periodic inspections of the collector heads to check for shoe wear. If the shoe height is less than 3/16" (5mm), the shoe should be replaced immediately. The shoe should also be immediately replaced if the shoe shows signs of overheating, is pitted, cracked, or chipped. If the wear pattern on the shoe is more than 10 degrees off of even, the shoe should be replaced and the collector mounting position should be re-evaluated. A minimum of 3/16" (5mm) to the nearest cover component (including overlap covers) should always be maintained.
- 4.12.2 Several conditions may lead to accelerated shoe wear. The most common conditions are:
- 4.12.2.1 A loss of contact with the conductor surface creates an overheating situation which will cause pitting in the conductor surface. This pitting further reduces electrical contact, exacerbating the overheat condition and in turn, creates more pitting. Improper installation may prevent the collectors from maintaining adequate contact with the conductor contact surface along part or all of the complete length of the runway. This may be due to:
- a. Poor alignment of the conductor mounting brackets in the vertical and horizontal places. In this case the collectors don't have enough travel to maintain good contact because the conductors don't stay within the optimal contact range of the collector.
 - b. Improper location of the collector mounting bracket relative to the conductor (too close or too far away). Too far away creates too little contact pressure and too close may cause the shoe to nose, or drag on one end.
 - c. Restricted movement of collector heads. It is essential that the collector pigtailed (feed cables) to the shoes have adequate free loop to allow rotation of the collector head throughout the full range of motion. Too short pigtailed can prevent good shoe contact and cause loss of contact.
 - d. Loosening of conductor joints. When too few expansion sections are used or when anchor clamps are loose, the conductor joints may separate. The gaps in the conductor contact surface caused by this separation can shave the shoes down and cause premature wear. If not detected in time, poor contact may result, creating overheating, pitting of the conductor, etc.
- 4.12.2.2 Contaminates in the environment may accumulate on the conductor contact surface. These contaminants need not be electrically insulating to cause problems. If they decrease the area of contact between the shoes and conductor, problems may arise with overheating, pitting, etc. Some contaminants may be abrasive, increasing the rate of shoe wear. In environments that are subject to considerable buildup of dust, especially conductive dust, remove the dust at regular intervals by brushing.
- 4.12.2.3 Corrosive elements may create deposits on the collector shoe and/or the conductor contact surface that decrease conductivity at the sliding contact surface. Under severely corrosive conditions, the copper graphite shoes may be corroded to the point where less than half of the shoe is remaining, decreasing the available contact surface area and causing overheating and pitting.
- 4.12.2.4 Infrequent maintenance of the collectors can lead to worn out shoes, poor contact, pitting, etc.

5.0 TROUBLESHOOTING

Problem	Possible Cause(s)	Possible Solution(s)
Overheating/Burning Conductor	Loose splice	Disassemble component, clean mating surfaces, apply EJC, and re-torque hardware replacing Belleville washers and nuts.
	Loose power feed and/or lug(s)	
	Overloading	Check electrical loading by doing a load survey. Rectify if not according to system parameters.
Arcing/pitting on the Stainless Steel Insert at a splice.	Loose splice	Disassemble component, clean mating surfaces, apply EJC, and re-torque hardware replacing Belleville washers and nuts.
	Misaligned conductors resulting in the copper shoe losing contact	Disassemble component, clean mating surfaces, apply EJC, realign conductors and re-torque hardware.
Arcing/pitting on the Stainless Steel Insert	Collector not making good contact with conductor	Check alignment of conductor with respect to vehicle. Adjust position of hanger clamp and/or hanger bracket. Verify contact force of collector is 6-7 lbs (26-31N). Replace tension spring on collector arm.
		Investigate stainless steel insert for debris and/or misaligned splice joints causing collector to bounce. Remove debris and/or align conductor in splice.
		Check vehicle's running surface for anything causing sudden lurch of the vehicle or excessive vibration. Adjust as necessary.
Arcing/pitting on the Stainless Steel Insert at an Isolation.	Large voltage potential between both sides of the isolation.	Check for debris and/or misaligned isolation joint causing the collector to bounce. Remove debris and/or align conductors adjusting for a smooth transition of the collector shoe as required.
		Splice short pieces of conductor on either side of the isolation that can be easily replaced when worn out. Compare voltage drop from feed points on either side of the isolation.
		Adjust the location of the power feeds if possible
Conductor Binding/Snaking in between Hanger Clamps	Hanger clamp not "square" with the conductor	Loosen hardware on hanger clamp, make square with conductor and retorque. Check for debris and/or crack in cover impeding expansion and contraction of conductor. Remove debris with compressed air and/or water. Replace cover if necessary.
	Expansion gap set incorrectly	Measure expansion gap and adjust according to the gap setting chart.
	Anchor clamp not tight	Check torque of the hardware on the anchor. Retorque as required. Check anchor clamps and verify none are cracked or fractured. Replace as necessary.
Shoe Chipping on Leading Edge	Misaligned splice, power feed, and/or isolation	Check alignment of conductor joints at splice, power feed, and isolations by running a shoe across the joint by hand. Adjust alignment of conductors as required.
	Insufficient contact force of shoe on conductor resulting in the shoe "tipping" up on the bar and impacting the leading edge.	Verify correct position of collector base to contact surface then measure the contact force of the shoe on the conductor with a spring scale. Contact force should be 6-7 lbs (26-31N). Replace spring if necessary.

5.0 TROUBLESHOOTING

Problem	Possible Cause(s)	Possible Solution(s)
Excessive Shoe Wear (<4000 miles/shoe)	Misaligned splice, power feed, and/or isolation	Check alignment of conductor joints at splice, power feed, and isolations by running a shoe across the joint by hand. Adjust alignment of conductors as required.
	Arcing/pitting on the stainless steel creating a rough surface	See "Arcing/pitting on the Stainless Steel Insert" above.
Uneven Shoe Wear on Leading vs. Trailing Edge	Insufficient contact force of shoe on conductor resulting in the shoe "tipping" up on the bar and impacting the leading edge.	Verify correct position of collector base to contact surface then measure the contact force of the shoe on the conductor with a spring scale. Contact force should be 6-7 lbs (26-31N). Replace spring if necessary.
	Misaligned splice, power feed, and/or isolation impacting shoe in one direction	Check alignment of conductor joints at splice, power feed, and isolations by running a shoe across the joint by hand. Adjust alignment of conductors as required.
Uneven Shoe Wear on Sides of Shoe	Incorrect position of tension spring on collector	Position hook of spring in top slot of pin base so spring is pulling the collector shoe into the conductor and "up" from the running surface (refer to collector drawing).

5.0 TROUBLESHOOTING

5.1 Typical 4 Bar Safe-Lec 2 System

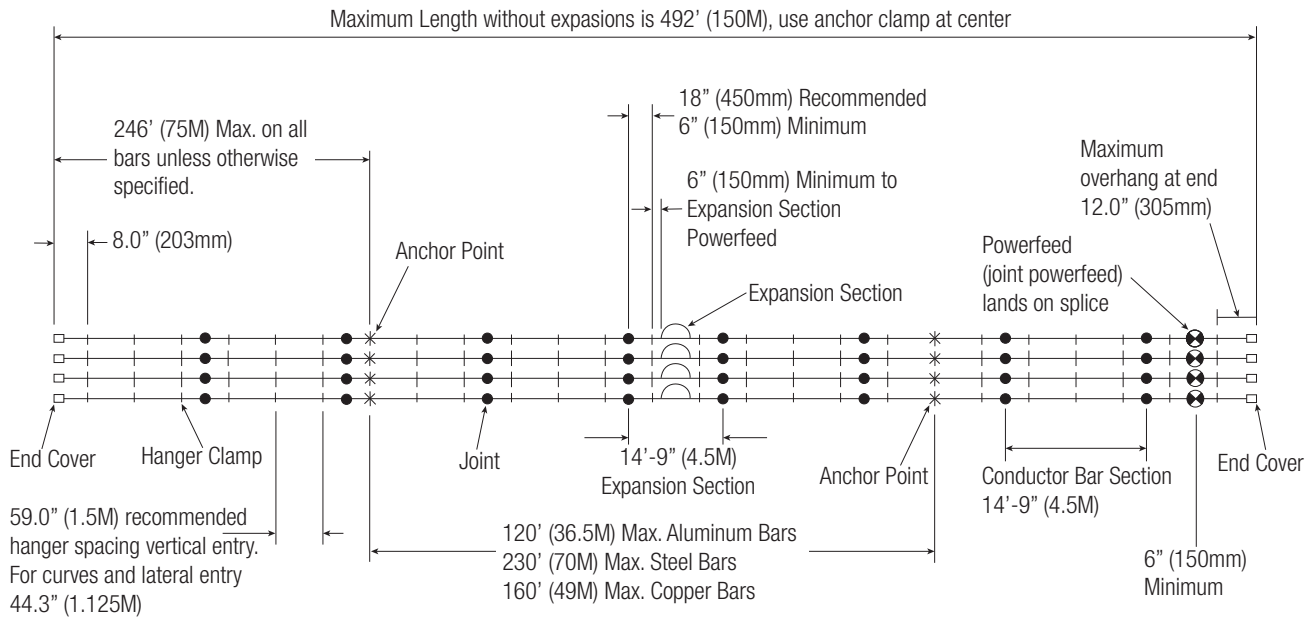

Legend

	Conductor Bar		Hanger Clamp
	Splice Joint		Anchor Location
	Expansion Section		Powerfeed
	Transfer Cap		Pickup Guide
	End Cap		Isolation Section Isolation = Air Gap
	Isolation Section Isolation = Insulated Material		Collector
			Power Interrupt

www.conductix.us

USA / LATIN AMERICA

10102 F Street
Omaha, NE 68127

Customer Support

Phone +1-800-521-4888

Phone +1-402-339-9300

Fax +1-402-339-9627

info.us@conductix.com

latinamerica@conductix.com

CANADA

1435 Norjohn Court
Unit 5
Burlington, ON L7L 0E6

Customer Support

Phone +1-800-667-2487

Phone +1-450-565-9900

Fax +1-450-951-8591

info.ca@conductix.com

MÉXICO

Calle Treviño 983-C
Zona Centro
Apodaca, NL México 66600

Customer Support

Phone (+52 81) 1090 9519

(+52 81) 1090 9025

(+52 81) 1090 9013

Fax (+52 81) 1090 9014

info.mx@conductix.com

BRAZIL

Rua Luiz Pionti, 110
Vila Progresso
Itu, São Paulo, Brasil
CEP: 13313-534

Customer Support

Phone (+55 11) 4813 7330

Fax (+55 11) 4813 7357

info.br@conductix.com

Contact us for our Global Sales Offices

