

# Push Button Pendants

## 80 | 60 | 20 Series



**CONDUCTIX**  
wampfler

# Contents

---

Conductix-Wampfler Push Button Pendants	3
<b>80 Series (2 to 24 Buttons)</b>	<b>4-17</b>
80 Series Features	4
Custom Pendant Order Sheet	5
Standard Configurations	6-7
Dimensions	8
Enclosures	8
Bushings	8
Switches	9-14
Accessories & Spare Parts	15
Jumpers	15
Legend Sheets	16
80 Series Pistol Grip	17
<b>60 Series</b>	<b>18-22</b>
60 Series Features	18
Complete Pendants and Switch Configurations	19
Dimensions	20
Cable Bushings	21
Legends	21
60 Series Pistol Grip	22
<b>20 Series Pistol Grip</b>	<b>23</b>
<b>Pendant Cable &amp; Accessories</b>	<b>24</b>
Pendant Cable	24
Strain Relief Cable & Hardware	24
Quick Disconnect Plugs	24
<b>Terms and Conditions</b>	<b>25</b>
<b>Conductix-Wampfler Radio Controls</b>	<b>26</b>
<b>Other Conductix-Wampfler Products</b>	<b>27</b>
<b>Conductix-Wampfler Contact Information</b>	<b>28</b>

---

**Don't see what you need? Give us a call!**

# Push Button Pendants

**Conductix-Wampfler** has assembled ergonomic, high quality Push Button Pendants since the early 1990's.

We offer dozens of standard Push Button Pendant configurations to suit the unique needs of demanding industrial users. These modular push button units are assembled from stocked components for quick delivery and are competitively priced.

The experienced engineering and sales people at Conductix-Wampfler are experts in the application of Push Button Pendants to all kinds of industrial applications

As an alternative to hard-wired "pendant stations", Conductix-Wampfler also offers radio remote controls. Please refer to catalog CAT1002 or contact the factory for more information.

All Conductix-Wampfler plants in the United States, Germany, France, and Italy are ISO 9001:2000 certified. Our stringent quality systems assure that you will get the right product every time. See Pg. 27 for a summary of our other fine products.

Conductix-Wampfler in the USA, headquartered in Omaha, NE, started as "Industrial Electric Reels" (IER) and later merged with "Insul-8 Corporation", after relocating the Insul-8 plant to Harlan, IA. In 2006 the company, part of the Delachaux Group since 1975, was renamed "Conductix".

In 2007, with the merger of Conductix and Wampfler, the company is now the world leader in the design and manufacture of high performance energy and data transmission products for industrial applications.



## Pre-Wiring Option

All pendants shown in this catalog can be ordered pre-wired. Contact the factory for details!



## 80 Series

Ergonomic; Accommodates from 2 to 12 buttons. Many configurations. High-impact NEMA 4X case with Neoprene-booted buttons. 2 and 3 button Pistol Grip versions available.



## 60 Series

Economical 2 or 4 button pendant. A 2-button Pistol Grip version is also available. High-impact NEMA 4 case.

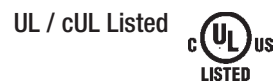

## 20 Series

For direct control over small single phase motors at 120 or 240 volts. Durable NEMA 4 housing.

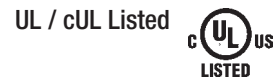

# 80 Series Push Button Pendant Features

The Conductix-Wampfler 80 Series Push Button Pendants are available with a wide variety of switch types, options, and accessories for easy customization. You can get from 2 to 12 buttons in a standard configuration or up to 24 buttons in a duplex configuration.

## 80 Series Pendants are ideal for:

- Overhead crane control
- Monorail and hoist control
- Conveyor and elevator control
- Workstations
- Assembly lines
- Other industrial machines

## Enclosure Features:

- High impact, yellow ABS enclosure
- Two-piece design to simplify field wiring
- Shock resistant to 100 g.
- Double-insulated to withstand 2500V
- UL/cUL Listed for indoor use only



## General Switch Features:

- One, two, and three-speed operators
- Silicon-booted buttons
- Easy-force buttons with positive detents for speed selections
- Switch contacts rated at 5 A (at 120 VAC)
- 5° F to 160° F (-15° C to 70° C) operating temperature range
- 5A @ 120VAC & 240VAC, 2A @ 24VDC & 12VDC, & .4A @ 120VDC

### Cable Packing Gland

Furnished with bushing available in 16 sizes; assures water tight seal.

### Lamp & Horn Switch

Knock-out holes in .47 inch (12mm) and .75 inch. (19mm) diameters. Available for a lamp and horn switches on 6 through 12 button enclosures.

### Fasteners

Self-captive stainless steel hardware and threaded inserts in housing to prevent thread stripping.

### Buttons

Silicone Rubber booted buttons. Seals out dirt and moisture. Available in red, green, and black.

### Jumpers

Included with all pre-assembled pendants - See Pg. 16.

### Cable Bushings

Available in 10 sizes from 0.30 in. to 1.16 inches (7.5mm to 29.5mm).

### Bushing Collar

Three sizes for cable diameters from 0.30 inches to 1.16 inches (7.5mm to 29.5mm).

### Hanger Ring

Located on the back of the bushing collar. For external strain relief connection. 'S' hook is available for strain relief cable connection - see Pg. 15.

### Enclosure

Ergonomic design, visible safety yellow, shock and vibration resistant, rugged ABS, 2 through 12 button. Standard Back or Deep Back styles. Two piece enclosure simplifies field wiring.

### Button Legends

Standard button legends are included. Vertical, selector, and mushroom legends are also available.

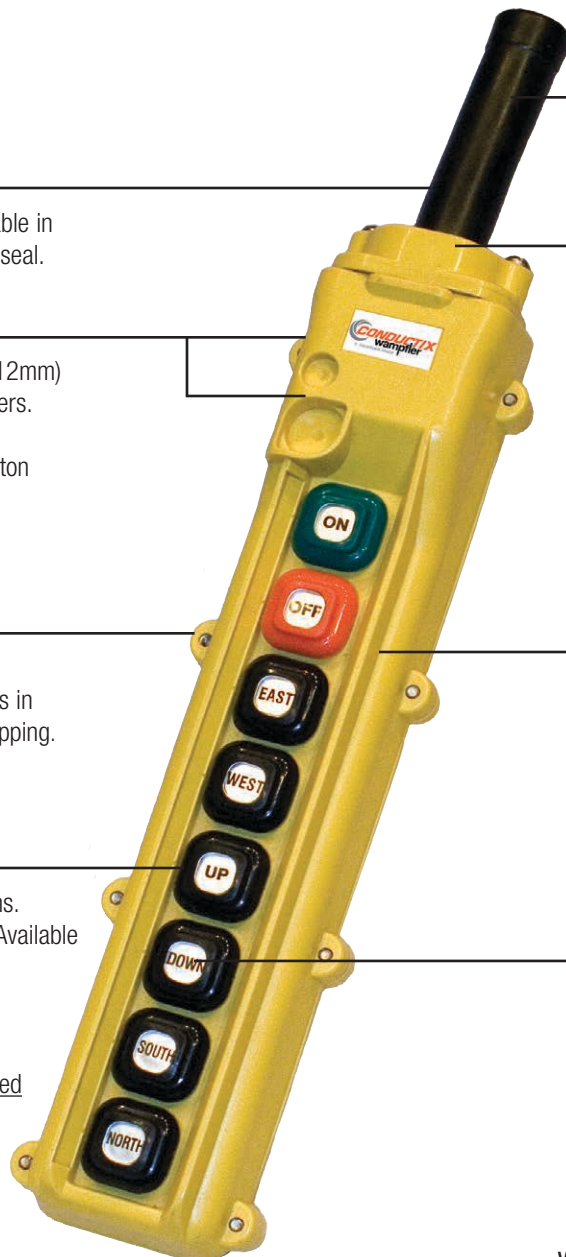



# Complete 80 Series Push Button Pendants

All Pendant Stations are fully assembled and include enclosure, operators, cable bushing, "S" hook and button legend sheet. Contact Conductix-Wampfler or your local representative for custom pendant stations. Jumpers included on assembled pendants only.



No. of Buttons	Switch Arrangement	Complete Unit Part No.	Bushing Part No.
2	Momentary On/Off (Red, Green)	34212	34411
2	Maintained On/Off (Red, Green)	34213	34411
2	Two 1-Speed	34214	34411
2	Two 2-Speed	34215	34411
2	Two 3-Speed	34216	34411
4	Two 1-Speed, With Momentary On/Off (Red, Green)	34217	34412
4	Two 1-Speed, With Maintained On/Off (Red, Green)	34218	34412
4	Two 2-Speed, With Momentary On/Off (Red, Green)	34219	34412
4	Two 2-Speed, With Maintained On/Off (Red, Green)	34220	34412
4	Two 3-Speed, With Momentary On/Off (Red, Green)	34221	34412
4	Two 3-Speed, With Maintained On/Off (Red, Green)	34222	34412
4	Four 1-Speed	34223	34412
4	Four 2-Speed	34224	34412
4	Four 3-Speed	34225	34412
6	Four 1-Speed, With Momentary On/Off (Red, Green)	34226	34413
6	Four 1-Speed, With Maintained On/Off (Red, Green)	34227	34413
6	Four 2-Speed, With Momentary On/Off (Red, Green)	34228	34413
6	Four 2-Speed, With Maintained On/Off (Red, Green)	34229	34413
6	Four 3-Speed, With Momentary On/Off (Red, Green)	34230	34413
6	Four 3-Speed, With Maintained On/Off (Red, Green)	34231	34413
6	Six One Speed	34232	34413
6	Six Two Speed	34233	34413
6	Six Three Speed	34234	34413
8	Six 1-Speed, With Momentary On/Off (Red, Green)	34235	34413
8	Six 1-Speed, With Maintained On/Off (Red, Green)	34236	34413



# Complete 80 Series Push Button Pendants

All Pendant Stations are fully assembled and include enclosure, operators, cable bushing, "S" hook and button legend sheet. Contact Conductix-Wampfler or your local representative for custom pendant stations. Jumpers included on assembled pendants only.



No. of Buttons	Switch Arrangement	Complete Unit Part No.	Bushing Part No.
8	Six 2-Speed, With Momentary On/Off (Red, Green)	34237	34413
8	Six 2-Speed, With Maintained On/Off (Red, Green)	34238	34413
8	Six 3-Speed, With Momentary On/Off (Red, Green)	34239	34413
8	Six 3-Speed, With Maintained On/Off (Red, Green)	34240	34413
8	Eight 1-Speed	34241	34413
8	Eight 2-Speed	34242	34413
8	Eight 3-Speed	34243	34413
10	Eight 1-Speed, With Momentary On/Off (Red, Green)	34244	39826
10	Eight 1-Speed, With Maintained On/Off (Red, Green)	34245	39826
10	Eight 2-Speed, With Momentary On/Off (Red, Green)	34246	39826
10	Eight 2-Speed, With Maintained On/Off (Red, Green)	34247	39826
10	Eight 3-Speed, With Momentary On/Off (Red, Green)	34248	39826
10	Eight 3-Speed, With Maintained On/Off (Red, Green)	34249	39826
10	Ten 1-Speed	34250	39826
10	Ten 2-Speed	34251	39826
10	Ten 3-Speed	34252	39826
12	Ten 1-Speed, With Momentary On/Off	34253	39826
12	Ten 1-Speed, With Maintained On/Off	34254	39826
12	Ten 2-Speed, With Momentary On/Off	34255	39826
12	Ten 2-Speed, With Maintained On/Off	34256	39826
12	Ten 3-Speed, With Momentary On/Off	34257	39826
12	Ten 3-Speed, With Maintained On/Off	34258	39826
12	Twelve 1-Speed	34259	39826
12	Twelve 2-Speed	34260	39826
12	Twelve 3-Speed	34261	39826

# 80 Series Pendant Enclosures and Bushings

## Single Enclosures

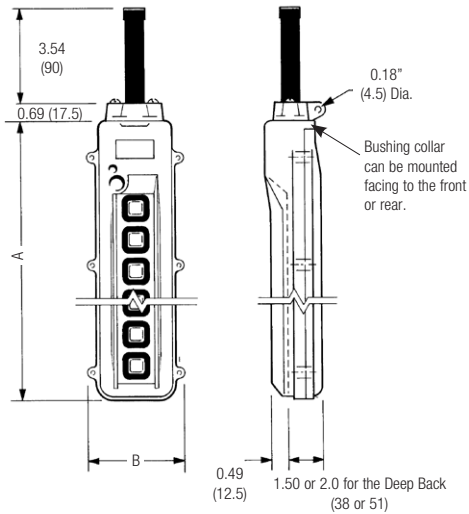

No. of Holes	"A" Dim.	"B" Dim.
2	4.49 (114)	3.07 (78)
4	7.09 (180)	3.07 (78)
6	10.31 (262)	3.23 (82)
8	12.68 (322)	3.23 (82)
10	15.24 (387)	3.43 (87)
12	17.60 (447)	3.43 (87)
12-24	Consult Factory	

## COMPLETE ENCLOSURE (FRONT AND BACK) (For different size bushings order from below)

# of Button Holes	Enclosure Depth	Inlet Size	Cable Diameter Range Inches (mm)	Part No.	Inlet Diagram
2	Standard	Small	.31 - .83 (8 - 21)	34274	
4	Standard	Small	.31 - .83 (8 - 21)	34275	
6	Standard	Small	.31 - .83 (8 - 21)	34276	
8	Standard	Small	.31 - .83 (8 - 21)	34280	
6	Standard	Large	.87 - 1.10 (22 - 28)	34278	
8	Standard	Large	.87 - 1.10 (22 - 28)	34282	
10	Standard	Large	.87 - 1.10 (22 - 28)	34286	
12	Standard	Large	.87 - 1.10 (22 - 28)	34290	
6	Deep Back	Small	.31 - .83 (8 - 21)	34277	
8	Deep Back	Small	.31 - .83 (8 - 21)	34281	
6	Deep Back	Large	.87 - 1.10 (22 - 28)	34279	
8	Deep Back	Large	.87 - 1.10 (22 - 28)	34283	
10	Deep Back	Large	.87 - 1.10 (22 - 28)	34287	
12	Deep Back	Large	.87 - 1.10 (22 - 28)	34291	

## Duplexed Enclosures

For details on pendants up to 24 buttons, contact the factory.

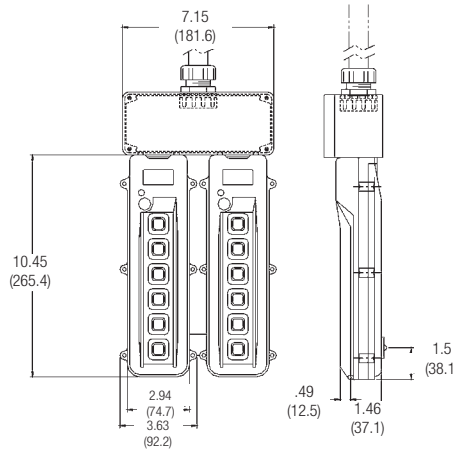

## Enclosure Bushings

Correctly sized bushings are necessary to prevent moisture from getting inside of the enclosure. Order based on cable O.D. and the part number of the enclosure the bushing is to be used on.

### For Enclosures 34274, 34275, 34276, 34280, 34277, & 34281:

Cable Size Range inches (mm)	Cable Bushing Part No.
.30 - .41 (7.5 - 10.5)	34411
.41 - .53 (10.3 - 13.5)	34412
.52 - .65 (13.3 - 16.5)	34413
.64 - .77 (16.3 - 19.5)	34414

### For Enclosures 34278, 34282, 34286, 34290, 34279, 34283, 34287, & 34291:

.52 - .65 (13.3 - 16.5)	39825
.64 - .77 (16.3 - 19.5)	39826
.76 - .89 (19.3 - 22.5)	34415
.88 - 1.00 (22.3 - 25.5)	34416
1.00 - 1.12 (25.3 - 28.5)	34417



# Pilot Lights & Horn Switches



Small Accessory Hole

Large Accessory Hole

## Pilot Light - Large



Red neon light, 19 mm diameter, for use with 6, 8, 10 and 12 button enclosures. Fits into large accessory hole in enclosure, not button space. [Note: These can be installed at the “small hole” location, but in that location, must be factory installed.]

Part No.	Voltage	No. of Wires*
36088	12 / DC	1
36081	24 DC / AC	1
34316	110 / AC	1

## Momentary Push Button Horn Switch



19mm diameter, for use with 6, 8, 10 and 12 button enclosures. Fits into large hole in enclosure, not button space.

Part No.	Resistive Load (Volts)	Amperage	No. of Wires*
34312	125 / AC	6	1
	250 / AC	3	1

## Pilot Light



22 mm diameter; takes up one button space.

Part No.	Voltage	No. of Wires*	Colors Available
XA-35181*	12 / DC	2	Red, Amber, Green
36042*	24 VAC / VDC	2	Red, Green, Blue
34303*	110 / AC	2	Red, Amber, Green
36882	110 / AC	2	Blue only

\* Typical wiring - for general information only. Number of wires will vary depending on the wiring method used.

\*\* Insert Light Color, if not red: G=Green, A=Amber, B=Blue  
Examples: XA-35181 = 12V DC, Red light  
XA-35181G = 12V DC, Green light

# 80 Series Pendant Switches

## Maintained On/Off

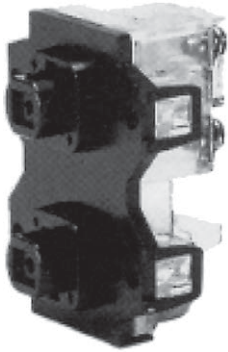

Part No.	No. of Wires*	Contact Configuration
34292	1	
34293	1	

## Momentary Non-Interlocking

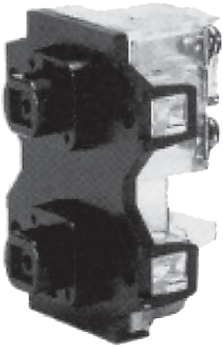

Part No.	No. of Wires*	Contact Configuration
34308	2	
34309	2	
34310	2	

## Dual Pole Momentary with Mechanical Interlock

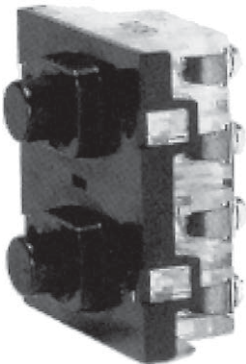

Part No.	No. of Wires*	Contact Configuration
34321	4	
34322	4	

\* Typical wiring - for general information only. Number of wires will vary depending on the wiring method used.

# 80 Series Pendant Switches

## Momentary 1-Speed with Mechanical Interlock

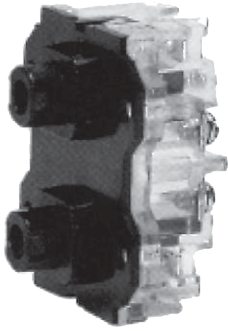

Part No.	No. of Wires*	Contact Configuration
34294	2	
34295	2	

## Momentary Single Button



Part No.	No. of Wires*	Contact Configuration
34305	1	
34306	1	
34307	2	
37114	2	
37199	2	

## Momentary 2-Speed with Mechanical Interlock

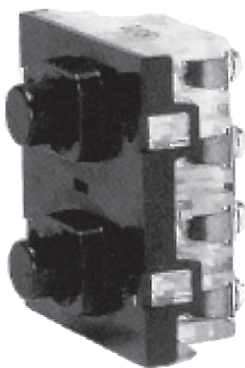

Part No.	No. of Wires*	Contact Configuration
34296	3	
34297	3	
34298	3	Same as 34297, but with delayed opening of contacts 7 & 8 "Break Before Make" contact arrangement

\* Typical wiring - for general information only. Number of wires will vary depending on the wiring method used.

# 80 Series Pendant Switches

## Momentary 3-speed with Mechanical and Electrical Interlock

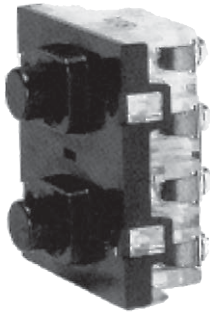

Part No.	No. of Wires *	Contact Configuration
34323	4	

## Maintained Multi-Position Selector Switch 2 position and 3 position

Other configurations available - contact factory.



Part No.	No. of Wires*	Contact Configuration
37107	1	
37108	1	
34317	2	
34318	2	
34319	2	
34320	2	
37109	2	
37110	2	

\* Typical wiring - for general information only. Number of wires will vary depending on the wiring method used.

# 80 Series Pendant Switches

## Push Lock Twist-Release Mushroom Switch



Part No.	No. of Wires*	Contact Configuration
34313	1	
37122	1	
37123	2	
37124	2	
37125	2	

## Alternating Push Button Switch



Part No.	No. of Wires*	Contact Configuration
34299	1	
34300	1	
37126	2	

\* Typical wiring - for general information only. Number of wires will vary depending on the wiring method used.

# 80 Series Pendant Switches

## Toggle switch



Note: Deep back enclosure required.

Part Number	No. of Wires*	Contact Configuration
34301	1	
34302	2	
37127	2	

## Variable Position Resistor



Max. Resistance (ohms)	Part No.	No. of Wires*	Contact Configuration
1,000	34314B	2	
2,000	34314D	2	
5,000	34314	2	
10,000	34314C	2	

## Blank plate



Part No.
34304

\* Typical wiring - for general information only. Number of wires will vary depending on the wiring method used.



# 80 Series Accessories, Spare Parts, and Jumpers



Item	Description	Part No.
Strain Relief Clamp	For Enclosures 34274 and 34275	<b>34626</b>
Strain Relief Clamp	For Enclosures 34276 through 34291	<b>34627</b>
"S" Hook Hanger	For Pendant Cables with Strain Relief Cable	<b>34332</b>
Bushing Collar, Small	For all 2 and 4 button pendants Cable O.D. - .30 - .77" (7.5 - 19.5 mm)	<b>34333</b>
Bushing Collar, Medium	For 6 and 8 Button Enclosures, with "Standard" inlet. Cable O.D.: 0.30" - 0.77" (7.5 - 19.5mm)	<b>50920</b>
Bushing Collar, Large	For 6, 8, 10, and 12 Button Enclosures with "Large" inlet. Cable O.D.: 0.76 - 1.16 (19.3 - 29.5mm)	<b>34334</b>
Switch Boot	Red	<b>34328</b>
Switch Boot	Black	<b>34329</b>
Switch Boot	Green	<b>34330</b>
Switch Boot Cover	Clear	<b>34331</b>
Deep Back Cover**	2 Button Enclosure	<b>34864</b>
Deep Back Cover**	4 Button Enclosure	<b>34866</b>
Deep Back Cover**	6 Button Enclosure	<b>36029</b>
Deep Back Cover**	8 Button Enclosure	<b>36030</b>
Deep Back Cover**	10 Button Enclosure	<b>36032</b>
Deep Back Cover**	12 Button Enclosure	<b>36033</b>

\*\* Includes the back over piece only

Jumpers (Used On One Switch)	Jumpers (Used From Switch to Switch)	Part No.	Jumper Label
On switch 34294 and 34295 to connect terminals 1 and 5.	To connect common between standard back selector, keyed, and mushroom switches.	<b>34759</b>	J80-01
	To connect between 1-speed, 2-speed, 3-speed, and ON/OFF switches.	<b>34760</b>	J80-02
On all 2-speed switches to connect terminal 6 to 4 and 14 to 16.	For connecting common between 2-speed switches by connecting terminal 16 of one switch to terminal 6 of adjacent switch.	<b>34761</b>	J80-03
	On all 3-speed switches to connect terminal 18 of two adjacent 3-speed switches and to connect terminal 8 of two adjacent 3-speed switches.	<b>35538</b>	J80-04
	To connect common of a maintained ON/OFF switch to adjacent 1-speed, 2-speed, or 3-speed switch.	<b>35000</b>	J80-06
On 2-speed switches to connect terminal 5 to 15.		<b>34992</b>	J80-12

# 80 Series Legend Sheets

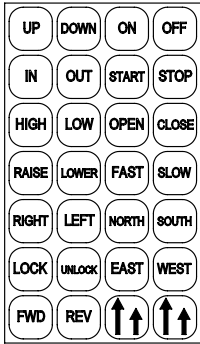

Button Legend - 34326

Legend/Sticker	Usage	Part No.
Button Legend	For push button marking.	34326
Mushroom Switch Legend	For mushroom switches	35299
Warning Sticker	n/a	35373
Vertical Legend	For case marking (Contact factory for legends sheets not listed.)	34327
Selector Switch Sheet #1	For case marking of selector switches	35300
Selector Switch Sheet #2	For case marking of selector switches	37228

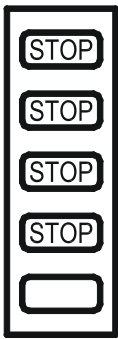

Mushroom Switch Legend - 35299

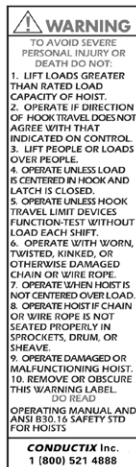

Warning Sticker - 35373

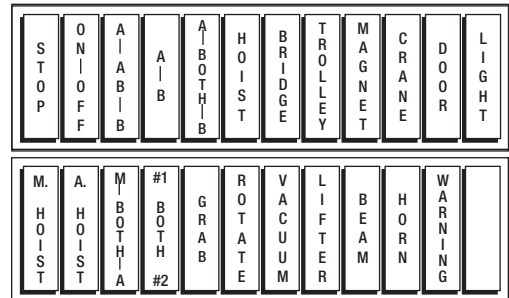

Vertical Legend - 34327

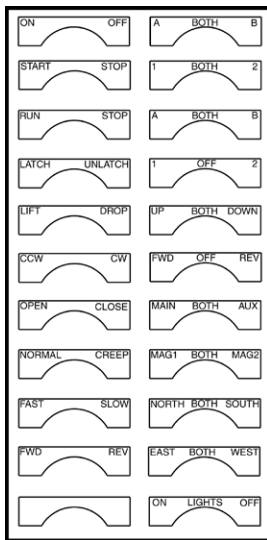

Selector Switch Legend #1 - 35300

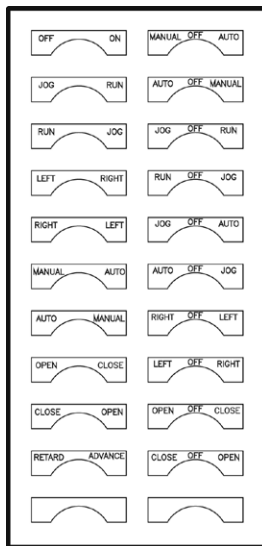

Selector Switch Legend #2 - 37228

# 80 Series Pistol Grip

## 80 Series Pistol Grip



The Conductix-Wampfler 80 Series Pistol Grip Pendants feature a compact, ergonomic design with the operator's comfort in mind. They are available with 1, 2, or 3 speed buttons. It is equipped to accommodate either internal or external strain relief cable.

UL/cUL Listed for indoor use only 

### Features:

- High impact, yellow ABS enclosure
- Multi-diameter cable bushing inlet

Speed	Part No.
1	COB81PB
2	COB81P
3	COB81PC

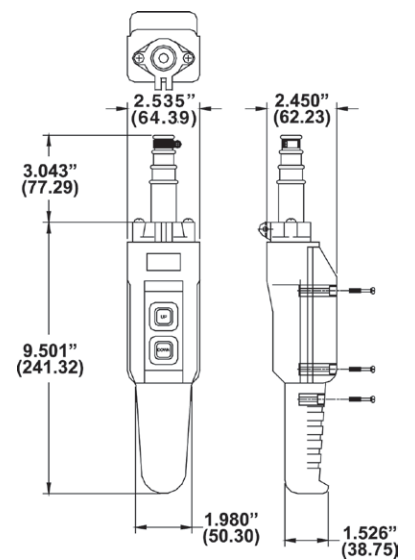

## 80 Series Pistol Grip, with 3 Button Holes



Same as the COB81, except that the top hole in the COB81.5P unit has an emergency stop button.

Speed	Part No.
1	COB81.5PB
2	COB81.5P
3	COB81.5PC

Note: E-Stop contact is 1NO & 1NC

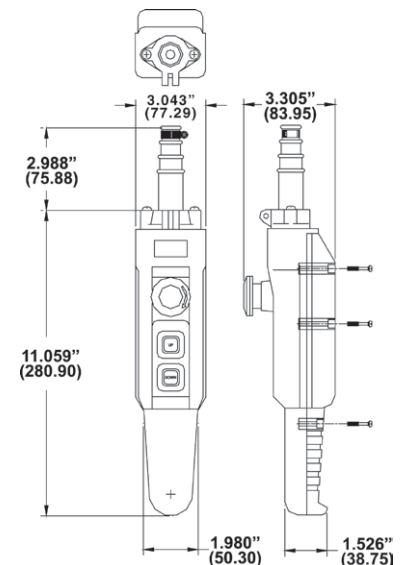

# 60 Series Pendant Features:

Conductix-Wampfler's 60 Series Pendant is designed for one hand, ergonomic operation in an economical package. The pendant is available in 2 or 4 button configurations with single-speed, silver-contact switches. All 60 Series pendants come pre-assembled.

UL/cUL Listed; File # 193531



## 60 Series Pendants are ideal for:

- Overhead crane control
- Workstations
- Monorail and hoist control
- Conveyor & Elevator Control

## Features

- Compact, high visibility orange enclosure
- NEMA 4 enclosure rating
- Ultra-long service life
- Contacts rated 5A at 250VAC
- 5°F to 160°F (-15°C to 70°C) operation
- 100g shock resistant

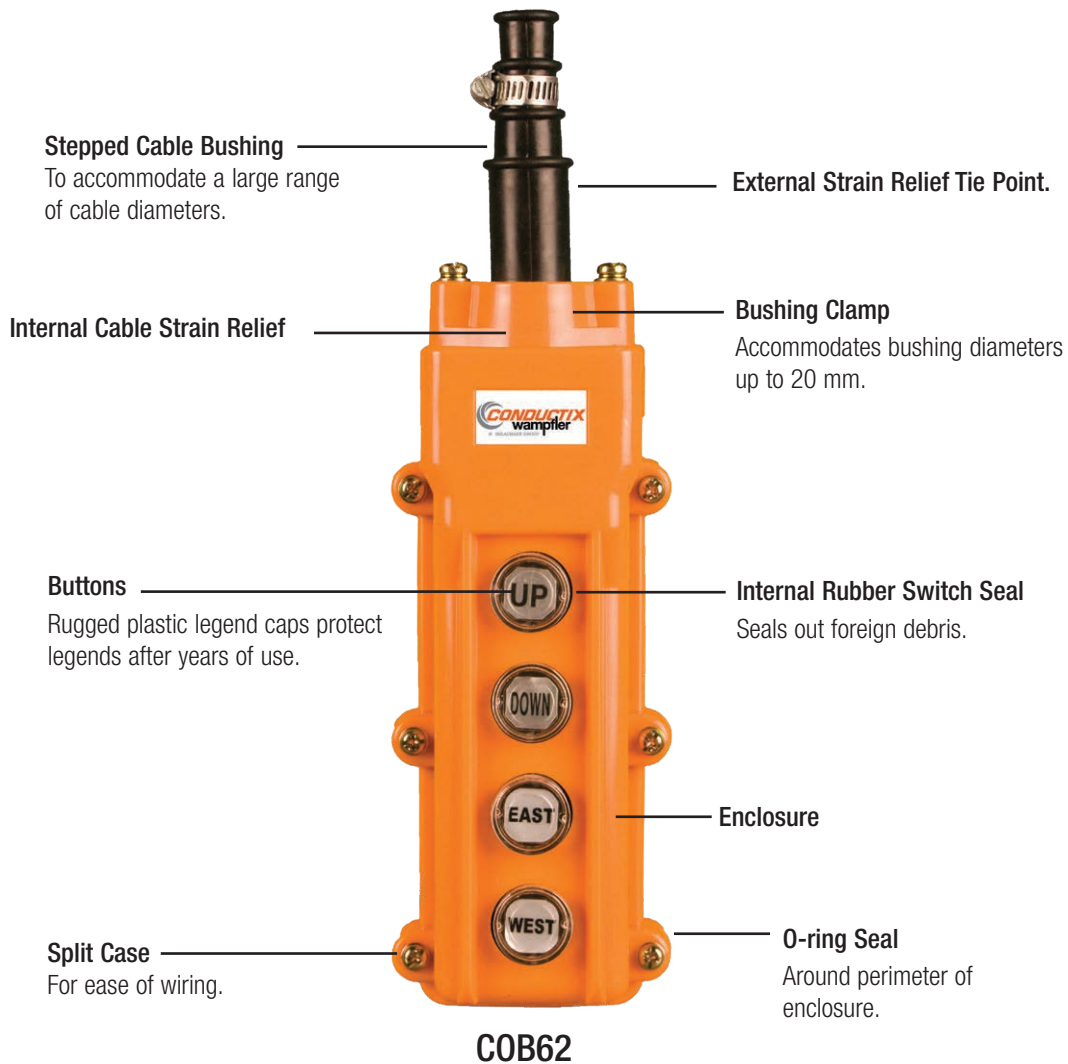

# 60 Series - Complete Pendants

## Complete Pendants

All switch terminals have 4mm screws. All pendants have standard cable bushing internal diameter (mm). CBVS (dia. 8-16 stepped)

**Switch Ratings:**

- 5A (24 VAC, 120 VAC, 250VAC. 500 VAC)
- 2 A (24 VDC)
- 0.4 A (120 VDC)

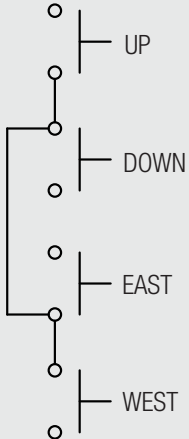

**COB61**

Number of Buttons	A	Part No.	Standard Cable Bushing	Switch Configurations
2 (1 pair)	All single speed	<b>COB61</b>	CBVS (8 to 16 mm stepped)	
4 (2 pair)	All single speed	<b>COB62</b>	CBVS (8 to 16 mm stepped)	

# 60 Series Dimensions

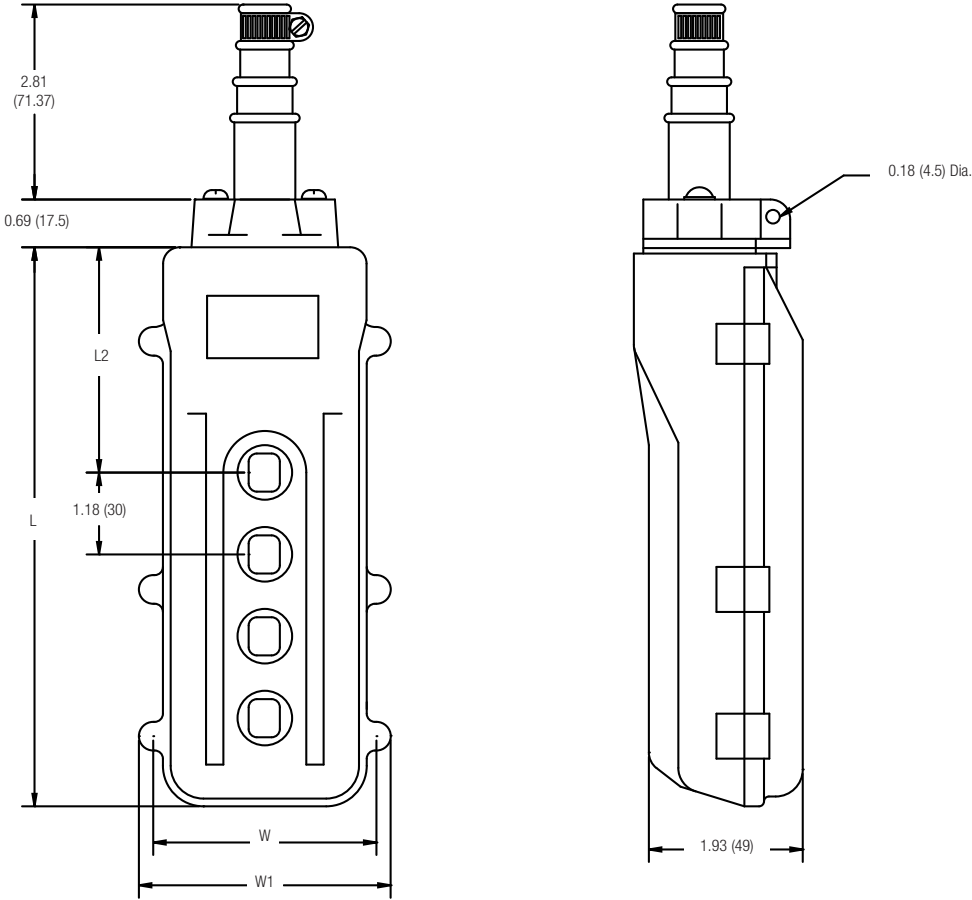

COB62 shown

Dimensions in inches (mm)

Dimension	Model COB61	Model COB62
L	4.45 (113)	7.25 (184.2)
L2	2.13 (54.1)	2.63 (66.8)
W	2.31 (58.7)	2.42 (61.5)
W1	2.77 (70.4)	3.05 (77.5)



# 60 Series Bushings, and Legend

## Cable Bushings

Standard "CBVS" bushing is provided unless otherwise specified at time of order entry.

Type	Applicable cable diameter in. (mm)	Part No.
Stepped	.31 - .62 (8 to 16)	CBVS
One size	.68 - .72 (17.2-18.3)	C18

## Legend Sheet

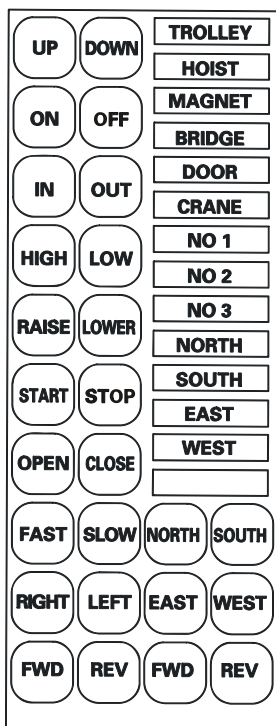

Part No.	Description
304COBLS	Legend Sheet

Part No.	Description
304COBCV	Clear button covers

# 60 Series Pistol Grip Pendant

Comfortable, ergonomic design weighing only 10 oz and measuring only 2" wide. The Series 60 Pistol Grip has "easy-force", single speed switches with a 5A / 125 V contact block; standard "up/down" labeling. Other labels are available. Switches have been tested to withstand over one million operations.

UL / cUL listed; File E193531



## Features:

- High-impact yellow ABS enclosure
- Waterproof NEMA 4 rating; indoor use only
- Internal and external strain relief
- Variable dia cable bushing inlet with clamp
- Ambient Temperature: 5°F to 160°F ( -15°C to +50°C)
- Vibration Resistance: 10g from 10-55 Hz

Part No.	Max Amps	Max. Volts AC
34211	5	125

Part No.	Description
304C0BCV	Clear button covers

## Series 60 Pistol Grip Dimensions

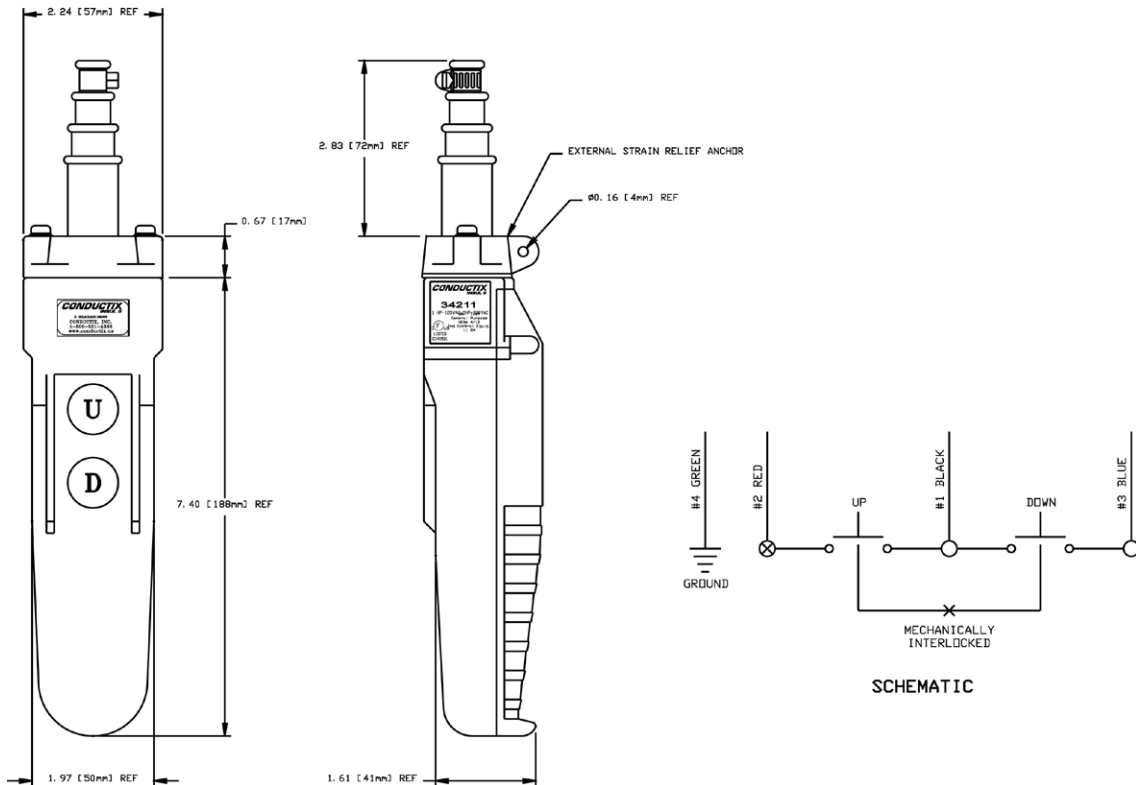

# 20 Series Pendant



Slim compact design suited for one-hand operation. Insulated for operator safety. Designed for direct control of single phase electric motors up to 1 HP @ 120 VAC or 2 HP @ 230VAC. Since motor current is controlled directly by the pendant switch, extra reversing contactors or costly controls are not required.

UL/cUL Listed File E193531 

## Features:

- Durable orange ABS pendant switch housing
- NEMA 4 water-proof enclosure
- Split case design for easy installation and wiring
- Flexible cable boot selection to match size of cable prevents entry of debris
- Two button switch with a wide range of legend markings
- Direct control ratings for 1HP max. @120 VAC (2HP @220 VAC)
- Electrical rating 25A resistive, 120 VAC (intermittent duty)

Part No.	HP Rating 120 VAC	HP Rating 220 VAC
35244	1	2

Part No.	Description
304C0BCV	Clear button covers

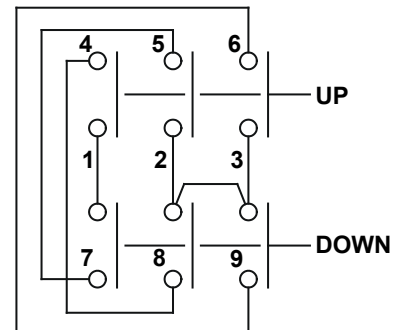
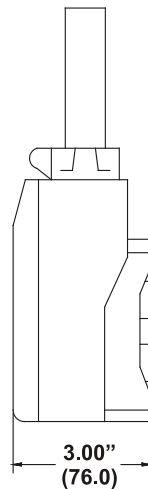
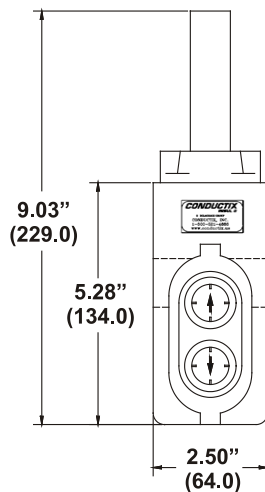

## Bushings

Standard "CBVS" bushing is provided unless otherwise specified at time of order entry.

Type	Applicable cable diameter in. (mm)	Part No.
Stepped	.31 - .62 (8 to 16)	CBVS
One size	.68 - .72 (17.2-18.3)	C18

# Pendant Cable, Strain Relief, and Quick Disconnect

## Pendant Cable



Conductix-Wampfler Pendant Cable has a yellow jacket and is resistant to sunlight, oil, and water.

### Temperature Rating:

- Without External Strain Relief: -10°C to 90°C (14°F to 194°F)
- With External Strain Relief: -10°C to 105°C (14°F to 221°F)



UL & CSA approved



### Standard Pendant Cable Without Strain Relief

Size AWG	No. of Conductors	Part No.	Diameter Nominal	Wt lb/ft (kg/m)
16	8	<b>83092</b>	0.465" (11.81)	0.145 (0.02005)
16	12	<b>83093</b>	0.550" (13.97)	0.200 (0.02765)
16	16	<b>83094</b>	0.605 (15.37)	0.255 (0.03526)
16	24	<b>83095</b>	0.745" (18.92)	0.375 (0.05185)
16	30	<b>83096</b>	0.785 (19.94)	0.455 (0.06291)
16	36	<b>83097</b>	0.885 (22.48)	0.540 (0.07466)



### Standard Pendant Cable with Attached Strain Relief

Size AWG	No. of Conductors	Part No.	Diameter Nominal	Wt lb/ft (kg/m)
16	8	<b>35398</b>	0.515" (13.08)	.210
16	12	<b>35399</b>	0.575" (14.61)	.260
16	16	<b>35400</b>	0.630" (16.00)	.330
16	24	<b>35401</b>	0.760" (19.30)	.430

Note: The steel Strain Relief Cable(s), if externally attached or separate, is 1/8" diameter or 3/16" diameter with nylon jacket.

### Round Pendant Cable with Internal Strain Relief

Size AWG	No. of Conductors	Part No.	Diameter Nominal	Wt lb/ft (kg/m)
16	3	<b>34155</b>	0.54" (13.72)	0.115
16	5	<b>34155C</b>	0.54" (13.72)	0.115
16	7	<b>34635</b>	0.62" (15.75)	0.230

## Separate Strain Relief Cable and Hardware

Item	Description	Part No.
Separate Strain Relief Cable	3/16" Dia. Nylon Steel Cable (1/8" dia. w/o nylon) - 480 lbs. (217.72 kg) cap. Ordered in feet.	<b>83098</b>
Hardware Kit	Includes (2) Thimbles, (4) U-Clamps, and (1) Eye Bolt	<b>83099</b>
Hardware Kit	Used with cable 35398 thru 35401	<b>36711</b>
Hardware Kit	used with Quick Disconnect Trolley	<b>39613</b>

## Quick Disconnect Plugs

Changing out a pendant has never been easier with these Quick Disconnect plug sets. Many other styles of connectors are available; please contact the factory.

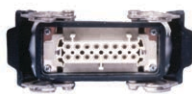

Female Mount Base

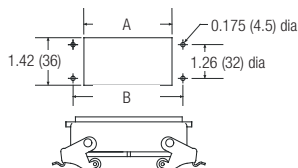

Male End

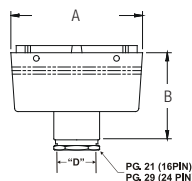

PG. 21 (16PIN)  
PG. 29 (24 PIN)

Description	Part No.	"A" Dim	"B" Dim
Bulkhead Mount Base 16 Pin Female Insert	<b>37766</b>	4.06 (106)	3.39 (86)
Bulkhead Mount Base 24 Pin Female Insert	<b>37767</b>	4.41 (112)	5.12 (130)

Description	Part No.	"A" Dim	"B" Dim	"D" O.D.
Top Entry Hood 16 Pin Male Insert	<b>41030</b>	3.68 (93.5)	2.28 (57.9)	0.39-0.75 (9.9-19.0)
Top Entry Hood 24 Pin Male Insert	<b>41032</b>	4.72 (119.9)	3.58 (90.9)	0.70-1.06 (17.8-26.9)

# Terms, Conditions, and Warranty

The technical data and images which appear in this catalog are for informational purposes only. NO WARRANTIES, EXPRESSED OR IMPLIED, INCLUDING WARRANTIES OF MERCHANTABILITY OR FITNESS FOR A PARTICULAR PURPOSE, ARE CREATED BY THE DESCRIPTIONS AND DEPICTIONS OF THE PRODUCTS SHOWN IN THIS CATALOG. Conductix-Wampfler (“seller”) makes no warranty and assumes no liability as to the function of equipment or the operation of systems built according to customer design or of the ability of any of its products to interface, operate or function with any portions of customer systems not provided by Conductix-Wampfler.

Seller agrees to repair or exchange the goods sold hereunder necessitated by reason of defective workmanship, and material discovered and reported to Seller within one year after shipment of such goods to Buyer. Except where the nature of the defect is such that it is appropriate in Seller’s judgment to effect repairs on site, the seller’s obligation hereunder to remedy defects shall be limited to repairing or replacing (at Seller’s option), FOB point of original shipment by Seller, any part returned to Seller at the risk and cost of Buyer. Defective parts replaced by Seller shall become the property of Seller.

Seller shall only be obligated to make such repair or replacement of the goods which have been used by Buyer in service recommended by Seller and altered only as authorized by Seller. Seller is not responsible for defects which arise from improper installation, neglect, or improper use or from normal wear and tear.

Additionally, Seller’s obligation shall be limited by the manufacturer’s warranty (and shall not be further warranted by Seller) for all parts procured from others according to published data, specifications, or performance information not designed by or for Seller.

Seller further agrees to replace, or at Seller’s option to provide a refund of the sales price of any goods that did not conform to applicable specifications or which differ from that agreed to be supplied which non-conformity is discovered and forthwith reported to Seller within thirty (30) days after shipment to Buyer. Seller’s obligation to replace or refund the purchase price for non-conforming goods shall arise once Buyer returns such good FOB point of original shipment by Seller at the risk and cost of Buyer. Goods replaced by Seller shall be come property of Seller.

There is no guarantee or warranty as to anything made or sold by Seller, or any service performed, except as to title and freedom from encumbrances, and except as herein expressly stated and particularly without limiting the foregoing. There is no guarantee or warranty, express or implied, of merchantability or of fitness for any particular purpose or against claim of infringement or the like.

Seller makes no warranty (and assumes no liability) as to function of equipment or operation of systems built to Buyer’s design or of the ability of any goods to interface, operate or function with any portions of Buyer’s system not provided by Seller.

Seller’s liability on any claim; whether in contract (including negligence) or otherwise, for any loss or damage arising out of, connected with, or resulting from the manufacture, sale, delivery, resale, repair, replacement or use of any products or, services shall in no case exceed the price paid for the product or services or any part thereof which give rise to the claim. In no event shall Seller be liable for consequential, special, incidental or other damages, nor shall Seller be liable in respect to personal injury or damage to property on the subject matter hereof unless attributable to gross misconduct of Seller, which shall mean an act of omission by Seller demonstrating reckless disregard of the foreseeable consequences thereof.

Seller is not responsible for incorrect choice of models or where products are used in excess of their rated and recommended capacities and design functions or under abnormal conditions. Seller assumes no liability for loss of time, damage or injuries to property or persons resulting from the use of Seller’s products. Buyer shall hold Seller harmless from all liability, claims, suits and expenses in connection with loss or damage resulting from operation of products or utilization of services, respectively, of Seller and shall defend any suit or action which might arise there from Buyer’s name - provided that Seller shall have the right to elect to defend any such suit or action for the account of Buyer. The foregoing shall be the exclusive remedies of the buyer and all persons and entitles claiming through the Buyer.



# Radio Remote Controls

**Conductix-Wampfler USA** has marketed ergonomic, economical, high quality, Radio Remote Controls since the early 1990's.

We offer a number of models to suit the unique needs of demanding industrial users. These units shipped from stock for quick delivery and are competitively priced.

The experienced engineering and sales people at Conductix-Wampfler are experts in the application of radio remote controls to all kinds of industrial applications

For more information, please contact Conductix-Wampfler.

All Conductix-Wampfler plants in the United States, Germany, France, and Italy are ISO 9001:2000 certified. Our stringent quality systems assure that you will get the right product every time. See Pg. 27 for a sampling of our other quality products.

Conductix-Wampfler USA, headquartered in Omaha, NE, started as "Industrial Electric Reels" (IER) and later merged with "Insul-8 Corporation", after relocating the Insul-8 plant to Harlan, IA. In 2006, the company, part of the Delachaux Group since 1975, was renamed "Conductix".

In 2007, with the merger of Conductix and Wampfler, the company is now the world leader in the design and manufacture of high performance energy and data transmission products for industrial applications.



## Protean™ Series

Economical Protean™ Radio Remote Control transmitters are available in 4, 6, & 8 button single-speed configuration. 330 foot (100 meter) range. FCC 310-320 Mhz AC and DC models.



## Protean™ HT and L8 Transmitters

2-motion, 2-speed HT and 3-motion 1-speed L8 models have positive detent positions, e-stop switch, and removable magnetic key. 330 foot (100 meter) range. FCC 310-320 Mhz AC and DC models.



## L10 and L12 Series

The L10 Series is a 2-speed transmitter with 8 buttons for control of 3-4 motions. The L12 is also 2-speed, but has 12 buttons for control of up to 5 motions. FCC 310-320 Mhz AC models only.



## L40 Series

A "belly box" style unit with 5-speeds, dual joystick. Up to 8 motions using A/B switches. FCC 310-320 Mhz AC models only.



## K1 and K2 Series

The rugged K1/K2 radios have eight 1-speed or 2-speed buttons for control over 3-4 motions. 330 foot (100 meter) range; FCC 433-435 MHz. AC or DC models.



## K3 and K4 Series

The K3/K4 has twelve 1-speed or 2-speed transmitter buttons for control over up to 5 motions. FCC 433-435 MHz. AC or DC models.



# Other Products from Conductix-Wampfler

The products described in this catalog represent a few of the products from the broad spectrum of Conductix-Wampfler components and systems for the transfer of energy, data, gases, and fluids. The solutions we deliver for your applications are based on your specific requirements. In many cases, a combination of several different Conductix-Wampfler products are needed to fill the application. You can count on all of Conductix-Wampfler's business units for hands-on engineering support - coupled with the perfect solution to meet your energy management and control needs.



### Motor driven cable reels

Motor driven reels by Conductix-Wampfler are the perfect solution for managing long lengths of heavy cable and hoses in very demanding industrial applications. Monospiral, level wind, and random wind spools.



### Slip ring assemblies

Whenever powered machinery needs to rotate 360°, field proven slip ring assemblies by Conductix-Wampfler can flawlessly transfer energy and data. Here, everything revolves around flexibility and reliability.

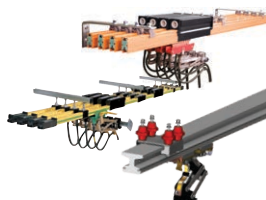

### Conductor bar

Whether they are enclosed conductor rails, expandable single-pole bar systems, or high amperage bar for demanding steel mill use up to 6000 amps. Conductix-Wampfler's conductor bar is the proven solution to reliably move people and material.



### Spring driven cable reels

We have 60 years experience and trusted brands such as Insul-8, Wampfler, and IER. We offer small cord reels all the way to large multi-motor units, a wide range of accessories, and hazardous location reels.



### Cable Festoon systems

It's hard to imagine Conductix-Wampfler cable trolleys not being used in virtually every industrial application. They are reliable and robust and available in an enormous variety of sizes and models.



### Push Button Pendants

Our ergonomic pendants are ideally suited for industrial control applications. They are available in a wide range of configurations for overhead cranes and other machinery.



### Radio remote controls

Safe, secure, and reliable radios use the latest in microprocessor technology. Available in several models for overhead crane control and other types of machinery.



### Inductive Power Transfer IPT®

The contact-less system for transferring energy and data. For all tasks that depend on high speeds and absolute resistance to wear.



### Energy guiding chains

The "Jack of all Trades" when it comes to managing energy and data cables and air and fluid hoses. A wide range of energy guiding chains are available for many industrial applications.



### Air hoists and balancers

ENDO Air hoists accurately place delicate loads and continuously vary the speed for precise positioning. They run cool in continuous operations.



### Bumpers

Conductix-Wampfler offers a complete range of bumpers for the auto industry, cranes, and heavy machinery. These include rubber, rubber/metal, and cellular types.



### Spring balancers and retractors

ENDO spring balancers by Conductix-Wampfler are rugged, reliable high-precision positioning devices that reduce operator fatigue and assist with accurate tool placement.

# www.conductix.us

## USA / LATIN AMERICA

10102 F Street  
Omaha, NE 68127

Customer Support  
Phone +1-800-521-4888

Phone +1-402-339-9300  
Fax +1-402-339-9627

info.us@conductix.com  
latinamerica@conductix.com

## CANADA

1435 Norjohn Court  
Unit 5  
Burlington, ON L7L 0E6

Customer Support  
Phone +1-800-667-2487

Phone +1-450-565-9900  
Fax +1-450-951-8591

info.ca@conductix.com

## MÉXICO

Calle Treviño 983-C  
Zona Centro  
Apodaca, NL México 66600

Customer Support  
Phone (+52 81) 1090 9519  
(+52 81) 1090 9025  
(+52 81) 1090 9013

Fax (+52 81) 1090 9014

info.mx@conductix.com

## BRAZIL

Rua Luiz Pionti, 110  
Vila Progresso  
Itu, São Paulo, Brasil  
CEP: 13313-534

Customer Support  
Phone (+55 11) 4813 7330

Fax (+55 11) 4813 7357

info.br@conductix.com

Contact us for our Global Sales Offices

