

Spring Cable Reel Manual

3200/3600 Power Reel[®]

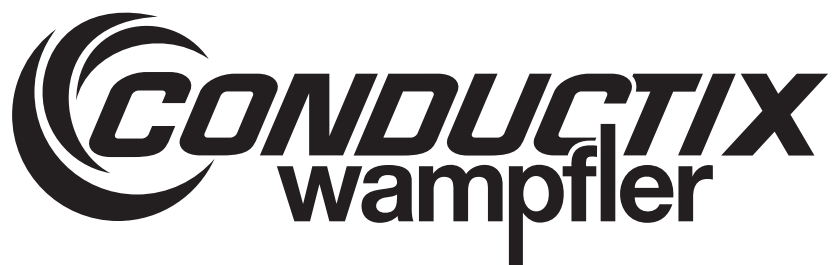

CONDUCTIX INCORPORATED

The technical data and images which appear in this manual are for informational purposes only. **NO WARRANTIES, EXPRESS OR IMPLIED, INCLUDING WARRANTIES OF MERCHANTABILITY OR FITNESS FOR A PARTICULAR PURPOSE, ARE CREATED BY THE DESCRIPTIONS AND DEPICTIONS OF THE PRODUCTS SHOWN IN THIS MANUAL.** Conductix makes no warranty (and assumes no liability) as to function of equipment or operation of systems built according to customer design or of the ability of any of its products to interface, operate or function with any portions of customer systems not provided by Conductix.

Seller agrees to repair or exchange the goods sold hereunder necessitated by reason of defective workmanship and material discovered and reported to Seller within one year after shipment of such goods to Buyer.

Except where the nature of the defect is such that it is appropriate, in Seller's judgment, to effect repairs on site, Seller's obligation hereunder to remedy defects shall be limited to repairing or replacing (at Seller's option) FOB point of original shipment by Seller, any part returned to Seller at the risk and cost of Buyer. Defective parts replaced by Seller shall become the property of Seller.

Seller shall only be obligated to make such repair or replacement if the goods have been used by Buyer only in service recommended by Seller and altered only as authorized by Seller. Seller is not responsible for defects which arise from improper installation, neglect, or improper use or from normal wear and tear.

Additionally, Seller's obligation shall be limited by the manufacturer's warranty (and is not further warranted by Seller) for all parts procured from others according to published data, specifications or performance information not designed by or for Seller.

Seller further agrees to replace or at Seller's option to provide a refund of the sales price of any goods that do not conform to applicable specifications or which differ from that agreed to be supplied which non-conformity is discovered and forthwith reported to Seller within thirty (30) days after shipment to the Buyer. Seller's obligation to replace or refund the purchase price for non-conforming goods shall arise once Buyer returns such goods FOB point of original shipment by Seller at the risk and cost of Buyer. Goods replaced by Seller shall become the property of Seller.

There is no guarantee or warranty as to anything made or sold by Seller, or any services performed, except as to title and freedom from encumbrances and, except as herein expressly stated and particularly, and without limiting the foregoing, **there is no guarantee or warranty, express or implied, of merchantability or of fitness for any particular purpose or against claim of infringement or the like.**

Seller makes no warranty (and assumes no liability) as to function of equipment or operation of systems built to Buyer's design or of the ability of any goods to interface, operate or function with any portions of Buyer's system not provided by Seller.

Seller's liability on any claim, whether in contract, tort (including negligence), or otherwise, for any loss or damage arising out of, connected with, or resulting from the manufacture, sale, delivery, resale, repair, replacement or use of any products or services shall in no case exceed the price paid for the product or services or any part thereof which give rise to the claim. In no event shall Seller be liable for consequential, special, incidental or other damages, nor shall Seller be liable in respect of personal injury or damage to property not the subject matter hereof unless attributable to gross misconduct of Seller, which shall mean an act or omission by Seller demonstrating reckless disregard of the foreseeable consequences thereof.

Seller is not responsible for incorrect choice of models or where products are used in excess of their rated and recommended capacities and design functions or under abnormal conditions. Seller assumes no liability for loss of time, damage or injuries to property or persons resulting from the use of Seller's products. Buyer shall hold Seller harmless from all liability, claims, suits, and expenses in connection with loss or damage resulting from operation of products or utilization of services, respectively, of Seller and shall defend any suit or action which might arise there from in Buyer's name - provided that Seller shall have the right to elect to defend any such suit or action for the account of Buyer. The foregoing shall be the exclusive remedies of the Buyer and all persons and entities claiming through the Buyer.

TABLE OF CONTENTS

SECTION 1 - SAFETY	5
Safety Information Responsibility	5
Safety Messages	5
Electrical Warnings	6
Operational Warnings	6
Maintenance Warnings	6
Specifications & Listings	6
Electrical Rating	6
Reels Not Equipped With Cable	6
Reels Equipped With Cable	6
Labels & Marking	7
Reels Equipped With Cable	7
Reels Not Equipped With Cable	7
SECTION 2 - OVERVIEW	8
SECTION 3 - INSTALLATION	9
Application Types	9
Stretch Applications	9
Lift Applications	9
Drag Applications	9
Retrieve Applications	9
Mounting	9
Standard Mounting	9
Pivot Base Mounting	10
Guide Rails	10
Roller Guides	10
Ratchet	11
Ratchet Option Installation	11
Ratchet Pawl Installation	11
Ratchet Plate Installation	11
Spool Lock	12
Cable Installation & Replacement	12
Cable Removal	12
Cable Installation	12
Cable Connections	12
Cable Loading	12

TABLE OF CONTENTS

Slip Ring Replacement	13
Electrical Connections	14
Electrical Warnings	14
Spool Cable Connections	14
Supply Cable Connections	14
Spring Tension Adjustment	14
Spring Tension Warnings	14
Spring Cycling	14
Spring Pre-Tensioning	14
Adjusting Spring Tension	14
SECTION 4 - OPERATION	15
SECTION 5 - MAINTENANCE	16
Maintenance Warnings	16
Lubrication	16
Inspections	16
Spring Motor Replacement	16
SECTION 6 - REPLACEMENT PARTS	18
R-Series Slip Rings for 3200, 3600 Series Cable Reels	18
Spring Reel Descriptive Numbering System for 3200, 3600 Series Cable Reels	19
SECTION 7 - TROUBLESHOOTING	20

SECTION 1 - SAFETY

Safety Information Responsibility

All owner, operator, and maintenance personnel must read and understand all manuals associated with this product before installation, operation, or maintenance.

The manual provides information on the recommended installation, operation, and maintenance of this product. Failure to read and follow the information provided could cause harm to yourself or others and/or cause product damage. No one should install, operate, or attempt maintenance of this product prior to familiarizing themselves with the information in this manual.

Safety Messages

The following safety messages are used in this manual to alert you to specific and important safety related information.



CAUTION

- CAUTION indicates unsafe actions or situations that have the potential to cause injury, and/or minor equipment or property damage.



DANGER

- DANGER indicates hazards that have the potential to cause severe personal injury or death.



WARNING

- WARNING indicates unsafe actions or situations that have the potential to cause severe injury, death, and/or major equipment or property damage.

NOTE

- NOTE is used to alert you to installation, operation, programming, or maintenance information that is important, but not hazard related.

SECTION 1 - SAFETY

Electrical Warnings

This equipment should be properly grounded before use, in accordance with both the National Electric Code and local codes and ordinances.

The electrical power should be disconnected from the cable reel before any service functions are performed.

The cable reel must not be used for loads greater than the voltage and current rating of the cable. The ampacity rating of the cable reel shall be in accordance with the National Electric Code.

Operational Warnings

Exercise care when handling the cable reel during normal operation. This cable reel has a rotating spool powered by springs under tension.

Do not use cable different from that for which the reel is intended. Changes in diameter, weight per foot, length of cable or flexibility will affect the operation of the reel.

Mounting hardware and fasteners should be installed to maintain tightness under vibration and checked periodically to assure tightness.

Overhead installation mountings should be such that the reel is not supported by bolts in tension. A safety chain or cable is strongly recommended to minimize damage and/or possible injury in the event of a mounting failure.

Maintenance Warnings

WARNING: Modification of this equipment may cause excessive wear and will void the warranty. Contact the manufacturer regarding changes or modifications of equipment which could affect reliability or safety.

DO NOT DISASSEMBLE THE SPRING MOTOR FOR ANY REASON. Serious personal injury could result. This cable reel is equipped with springs under tension. Contact the factory for assistance.

US: 1-800-521-4888

Canada: 1-800-667-2487

Specifications & Listings

The following specifications apply to all 3200/3600 Series Cable Reels.

3200 / 3600 Series Cable Reels are intended for commercial / industrial use and are provided with a permanent mounting base.

3200 / 3600 Series Cable Reels are built to NEMA 4 Specifications and are suitable for indoor/ outdoor use.

Spring Motors for the 3200 / 3600 Series are sealed for safety and weather-tight for long life.

Ampere capacity of the 3200 / 3600 Series Reels range from 10 to 150 Amperes at 600 Volts maximum. Reels are available in 3 to 36 conductor configuration.

3200 / 3600 Series Cable Reels are available with optional features which increase serviceability. Options include: ratchet, pivot base, spool lock, junction box, and guide rails.

Custom power and signal circuit slip rings using silver plated rings and silver graphite brushes are available upon request.

Electrical Rating

Reels Not Equipped With Cable

Reels not equipped with flexible cable are rated in amperes and volts for the cable intended or the slip ring capacity. Consult tables on the following pages for appropriate cable/conductor combinations.

The rating of the cable should not be greater than the ampacity of the slip ring circuit. See Slip Ring Replacement Chart. Consult tables on the following pages for appropriate cable/conductor combinations.

Reels Equipped With Cable

Reels equipped with flexible cable should not be used at voltages and/or amperages above the rating of the reel or cable.

SECTION 1 - SAFETY

Labels & Marking

Every cable reel is marked with a label on the frame which includes the Conductix name and logo, the product catalog number and the individual product serial number.

Reels Equipped With Cable

The marking on reels equipped with a flexible cable shall include the current and voltage ratings.

Reels Not Equipped With Cable

The rating of the reel not equipped with cable is completed upon installation and is based on the wire size and number on conductors. (See Tables below). The marking shall include the following:

- ___# The type (SOW, W, G-GC, etc.),
- ___# The AWG cable size,
- ___# The maximum length of cable with which the reel is intended for use.

The maximum cable footage, amperage and voltage rating for every cable reel supplied without cable is marked on the Conductix Identification Label. The actual cable installed should not differ from what is indicated on the Conductix label. If the cable must be different please consult the factory prior to installing the cable to ensure the change will not affect the reliability of the reel or the safety of the people working with the reel.

Type W (90°C)	
Cable	Ampacity
W 8/2	50
W 8/3	50
W 8/4	45
W 6/2	65
W 6/3	65
W 6/4	55
W 4/2	75
W 4/3	75
W 4/4	65
W 2/2	110
W 2/3	110
W 2/4	100
W 1/2	140

Type G-GC(90°C)	
Cable	Ampacity
G 8/3	50
G 6/3	65
G 4/3	85
G 2/3	115

Type SOW-A, S00W-A (90° C)			
Cable	Ampacity	Cable	Ampacity
16/2	10	12/2	20
16/3	10	12/3	20
16/4	8	12/4	16
16/5	8	12/5	16
16/6	8	12/6	16
16/7	7	12/7	14
16/8	7	12/8	14
16/10	7	12/10	14
16/12	7	12/12	14
16/14	7	12/14	14
16/16	7	12/16	14
16/20	7	12/20	14
16/24	6	12/24	14
16/30	6	12/30	12
16/36	6	10/2	25
14/2	15	10/3	25
14/3	15	10/4	20
14/4	12	10/5	20
14/5	12	10/6	20
14/6	12	10/7	17.5
14/7	10.5	10/8	17.5
14/8	10.5	10/10	17.5
14/10	10.5	10/12	17.5
14/12	10.5	10/14	17.5
14/14	10.5	10/16	17.5
14/16	10.5	-	-
14/20	10.5	-	-
14/24	10.5	-	-
14/30	9	-	-
14/36	6	-	-

Color Code Chart		
Cond. No.	Base Color	Tracer Color
1	Green	-
2	Black	-
3	White	-
4	Red	-
5	Orange	-
6	Blue	-
7	White	Black
8	Red	Black
9	Green	Black
10	Orange	Black
11	Blue	Black
12	Black	White
13	Red	White
14	Green	White
15	Blue	White
16	Black	Red
17	White	Red
18	Orange	Red
19	Blue	Red
20	Red	Green
21	Orange	Green
22	Black	-
23	White	-
24	Red	-
25	Green	-
26	Orange	-
27	Blue	-
28	White	Black
29	Red	Black
30	Green	Black
31	Orange	Black
32	Blue	Black
33	Black	White
34	Red	White
35	Green	White
36	Blue	White

SECTION 2 - OVERVIEW

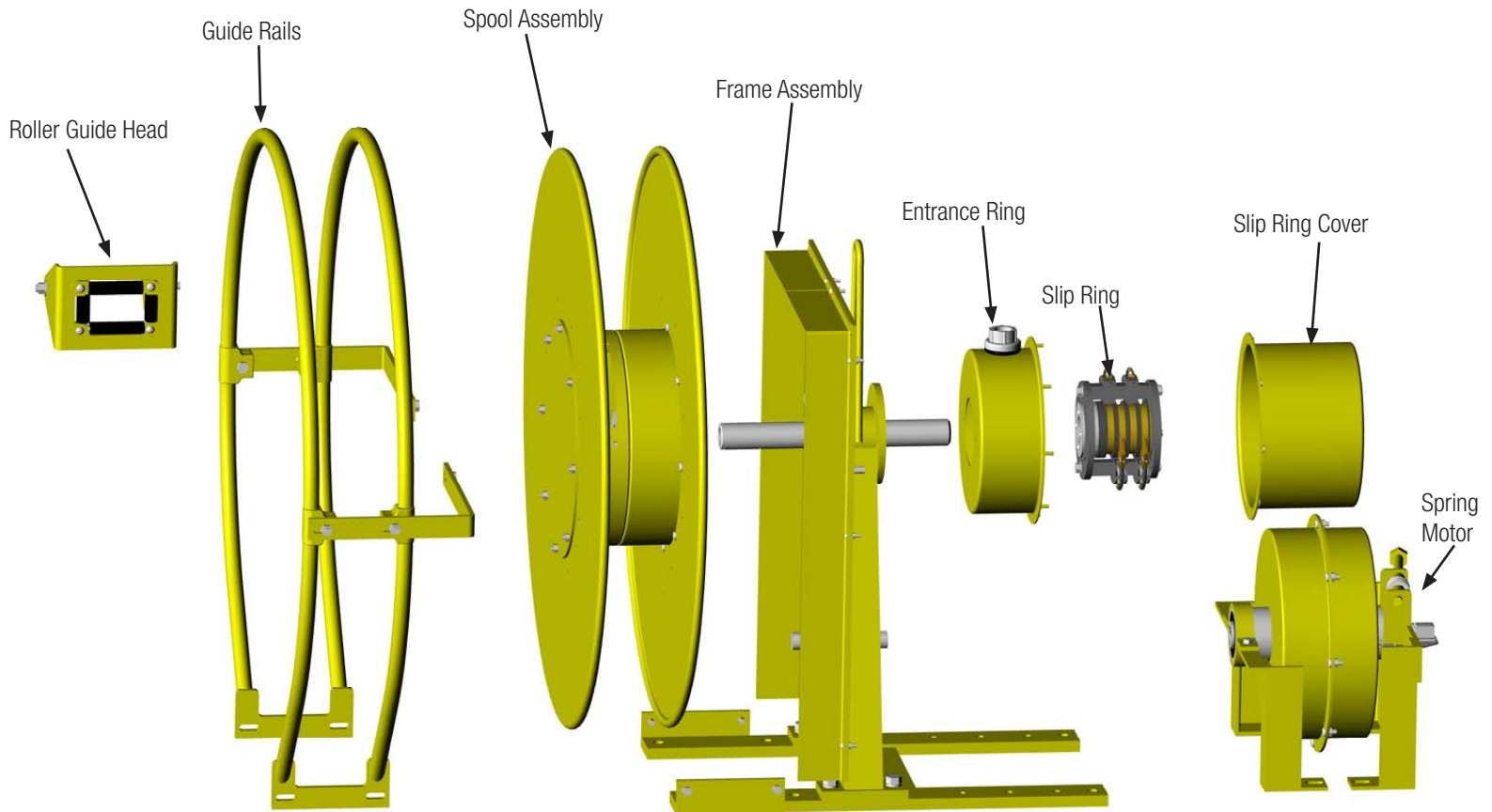

SECTION 3 - INSTALLATION

Application Types

Stretch Applications

The cable is suspended without any intermediate support. Stretch reels generally require a line pull equal to two times the weight of the cable, which allows approximately 10% sag at full extension. On long applications where sag cannot be tolerated, it is sometimes desirable to put supports at intervals of 5 to 10 feet. See **Figure 9-1**.

Lift Applications

The cable is lifted vertically in lift applications. The reel is normally designed to handle only the total weight of the cable. Some lift applications may require a ball stop and ratchet to control the length of cable to be retracted. See **Figure 9-2**.

Drag Applications

The reel is mounted on a stationary object and is required to drag the cable over the surface to the reel. The cable is supported by the ground or some type of cable tray. A ball stop may be required. See **Figure 9-3**.

Retrieve Applications

The reel is mounted on the moving object and winds up or pays out the cable as the machine approaches or moves away from the fixed end. See **Figure 9-4**.

Mounting

Standard Mounting

1. Mount the base of the reel to any flat surface which is structurally sound enough to support the reel and the forces of winding and unwinding the cable.
2. The spool drum must be mounted horizontally axis.
3. The cable should extend perpendicular to the rotation of the spool. The total cable deflection should not exceed 15° to either side of the centerline of the spool. See **Figure 9-5**.
4. If deflection is constant to either side of the reel and operation is impaired, re-mount the reel.
5. If the angle of deflection exceeds 30° , a Pivot Base or two way payout guide should be used, otherwise excessive cable wear and unreliable operation will result. See **Figure 9-5**.
6. A safety chain is recommended for all overhead installations. Attach the safety chain around the base plate bar.

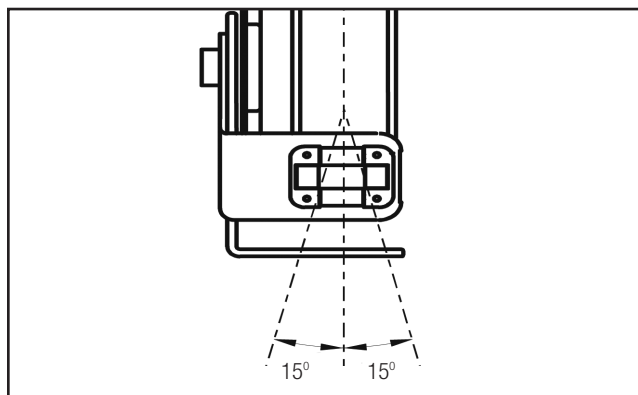

Figure 9-5 Cable Deflection with Roller Guide

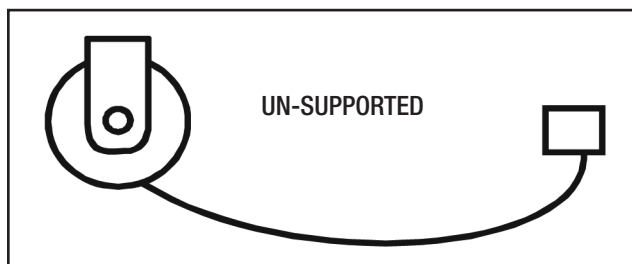

Figure 9-1

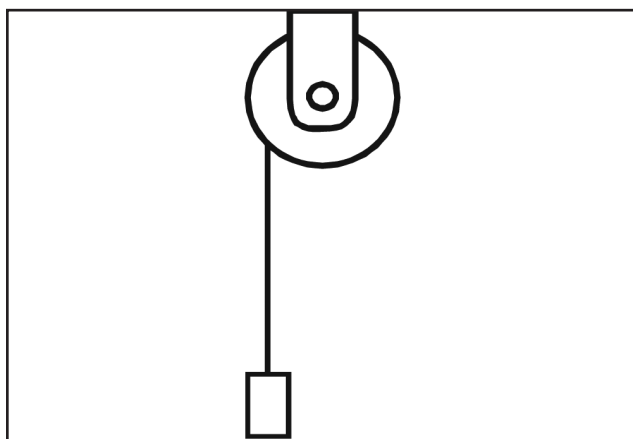

Figure 9-2

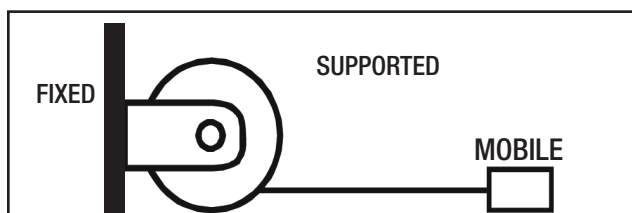

Figure 9-3

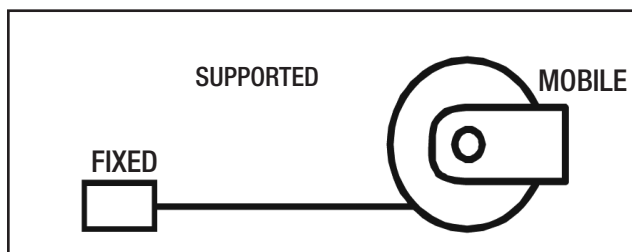

Figure 9-4

SECTION 3 - INSTALLATION

Pivot Base Mounting

All 3200 / 3600 Series Cable Reels can be furnished with a pivot base to allow the reel to rotate and keep the extended cable perpendicular to the application. See **Figure 10-1**.

Pivot Bases rotate up to 345°. If 360° rotation is required contact the factory.

A pivot base is required in carousel or loop-track applications.

When a pivot base is used the reel must be mounted horizontally (“ceiling” or “floor” mounted).

The Roller Guide should be mounted to require the cable to travel perpendicular to the axis of pivot base rotation. This will guard against cable twisting and ensure effective swivel action from the pivot base.

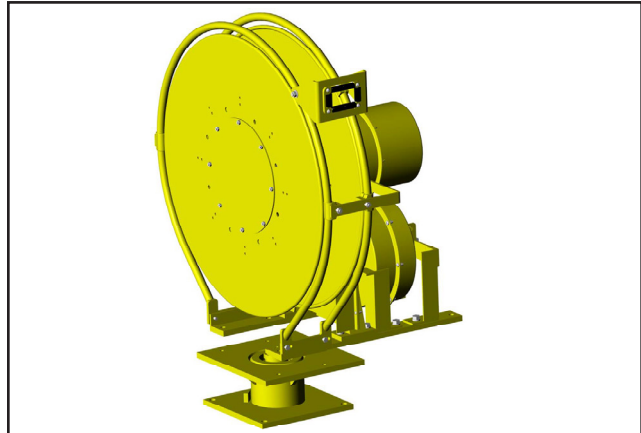

Figure 10-1

Guide Rails

Guide Rails provide a barrier between the cable and the rotating spool flange rim. They also act as a safety barrier for installations where human contact with the rotating spool flange is likely to occur. See **Figure 10-1**.

Guide Rails provide additional assurance that the cable will wrap efficiently on the spool for applications involving rigorous motion.

Guide Rails can act as a substitute for the roller guide in applications that require a two-way pay-out.

Roller Guides

All 3200 / 3600 Series Cable Reels are equipped with an adjustable roller guide. The guide's function is to center the cable on the spool and to help the reel wrap cable more evenly. See **Figure 10-2**.

Level winding is inhibited by the cable bearing against either of the spool flanges during operation. The Roller Guide helps to alleviate this condition.

The guide consists of the guide head. The guide must be adjusted and secured prior to terminating any electrical connections.

The guide should be secured at the position that causes the least change of cable direction to occur at the guide; otherwise, cable life will be reduced.

The guide head is mounted to the guide rails with the use of four clamp halves and two 3/8 - 16 carriage bolts. Mount the guide head on the guide rails in the desired position by placing one half clamp on each side of each rail and placing the guide head around the outside of the clamps. Insert the carriage bolts from the inside outward such that the carriage head is towards the center of the spool. This will prevent the cable from rubbing on any square edges. Install lock washers and nuts. The guide head may be tipped through 90° of travel to allow for minimum cable drag through the roller guide. See **Figure 10-3**.

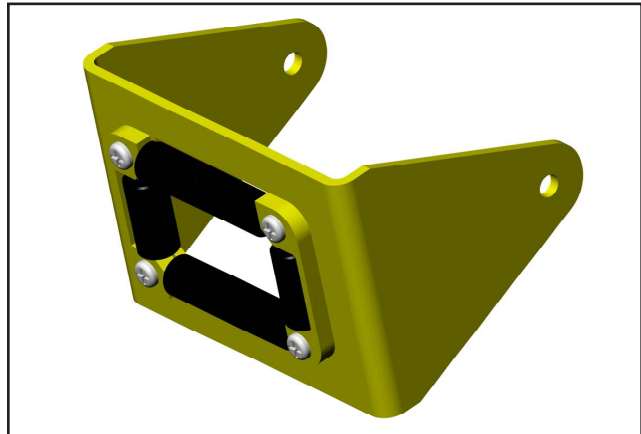

Figure 10-2



Figure 10-3

SECTION 3 - INSTALLATION

Ratchet

The ratchet option allows the extended cable to be pulled out and held from retraction by spring tension; generally appropriate for operator attended applications. See **Figure 11-1**.

The ratchet for the 3200 / 3600 Series Cable Reels is spring loaded. It is designed to function in all acceptable mounting configurations.

The ratchet option can be installed at the time of purchase or later added to reels that have already been introduced to service.

Ratchet Option Installation

WARNING

- Power should be disconnected from the reel before beginning any service or maintenance functions. Follow lock-out/tag-out procedures appropriate to the installation.

Ratchet Pawl Installation

The ratchet pawl assembly is attached to the reel frame as a unit. The holes provided for the attachment of the ratchet pawl assembly are located in the lower middle area of the frame.

1. Insert the (1) provided 3/8 - 16 bolts in the frame.
2. Position the ratchet pawl assembly over the protruding bolt shaft.
3. Secure using the two (2) provided sets of 3/8-16 hex nuts & lock washers.

Ratchet Plate Installation

The cable must be extended far enough to allow the removal of the two or four frame side flange bolts. See **Figure 11-2**.

1. Substitute the provided longer flange bolts and nuts for the removed bolts and nuts.
2. Position the ratchet plate over the bolts on the outside of the frame side flange. The ratchet teeth should be oriented as in the figure below (for standard rotation reels).
3. Secure the ratchet plate to the spool by tightening the nuts to approximately 7 (seven) ft-lbs.

Additional ratchet plates may be installed but will increase the likelihood of spool lock-up at full cable extension.

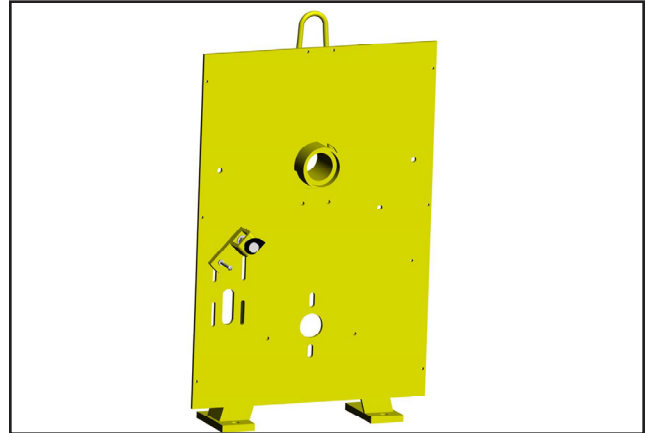

Figure 11-1

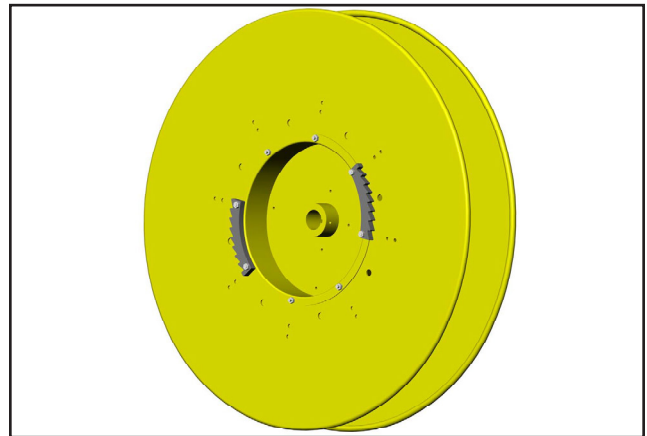

Figure 11-2

SECTION 3 - INSTALLATION

Spool Lock

All 3200 / 3600 Series Cable Reels can be equipped with an optional Spool Lock.

The Spool Lock allows the power spring tension to be locked out from the cable spool. Applications that often require cable replacement would benefit from the addition of the Spool Lock.

The cam action design of the Spool Lock maintains engagement under conditions of shock & vibration. This is good for applications which require the cable to remain extended and are subject to severe service conditions. See **Figure 12-2**.

Cable Installation & Replacement

Cable Removal

If an existing cable is being replaced you must first remove the old cable. See **Figure 12-1**.

1. Disconnect all power as per Lock-Out / Tag-Out procedures as outlined in OSHA section 1910.147.
2. Remove Spool Drum Cover Plate.
3. Mark existing cable connections.
4. Disconnect wires at the Drum Terminals.
5. Loosen the cable clamp and release the cable.
6. Loosen strain relief/watertight in the recessed Inlet Box on the spool.
7. Pull out and discard old cable.

Cable Installation

1. Prepare the cable to be loaded on to the reel. Support the cable as shown, or lay the full length of cable out in the direction of travel. Make sure the cable will lay flat by removing any twist from the cable.
2. Insert the end of the cable to be connected to the slip ring through the guide and through the recessed inlet box on the spool. Pull enough cable through the inlet box and cable clamp to allow unrestrained connections to the terminals. See **Figure 12-3**.
3. Unscrew the two parts of the strain relief / watertight and slide both sections and the neoprene grommet over the end of the cable as shown. Be sure to keep the fastening end last. See **Figure 12-3**.

Cable Connections

1. Connect the cable to the terminals (16AWG to 8AWG).
2. Secure the watertight connector. Jacketed cable should intrude 1-2 inches into the drum.

Cable Loading

1. Wind the cable onto the spool by rotating the spool counterclockwise, as viewed from the spool side (for standard rotation reels). See **Figure 12-4**.
2. Follow Spring Tensioning Procedure to adjust the spring tension as required by the application.
3. Verify all connections before initiating or restoring electrical power to the cable reel.
4. Visually inspect both reel and cable after initial electrification.

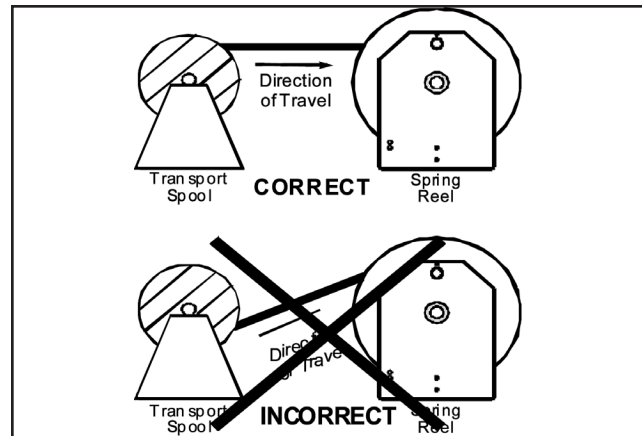

Figure 12-1

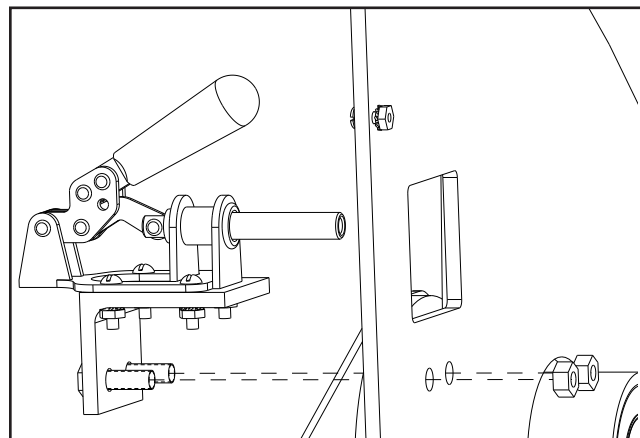

Figure 12-2

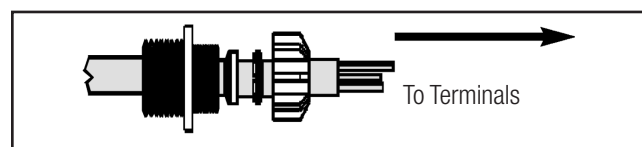

Figure 12-3

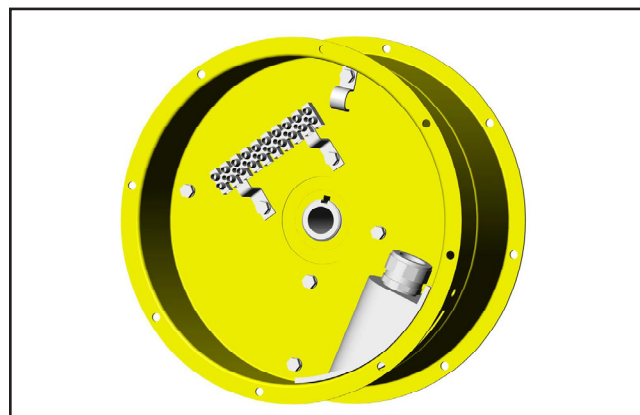

Figure 12-4

SECTION 3 - INSTALLATION

Slip Ring Replacement

1. Disconnect and secure the electrical power as per Lock-Out/Tag-Out procedure outlined in OSHA 1910.147, Appendix A.
2. Remove the Slip Ring cover.
3. Disconnect the Feeder Cable Connections from the Slip Ring Brush Terminals. Mark/Note the existing cable connections. See **Figure 13-1**.

CAUTION

- Incorrect connection of lead terminals will result in unit failure.

4. Disconnect the Slip Ring Core Leads from the spool terminals.
5. Loosen the two 1/4-20 Set Screws in the drive collar using a 1/8" Hex (Allen) Wrench.
6. Remove the Slip Ring from the end of the spool shaft.
7. After removing the Slip Ring use a file or emery cloth to remove the set screw burrs from the spool shaft. If the burrs are not removed the Slip Ring may not slide on the shaft. Be sure to clean out all filings and dust from inside the enclosure.
8. Install the new Slip Ring on the shaft.
9. Be sure the hole in the Slip Ring Outboard Bearing closest to Brush #2 fits over the Drive Pin. The Drive Pin must extend through the hole. See **Figure 13-3**.
10. Secure Set Screws to 7 ft-lbs.
11. Connect the new Slip Ring to both the Spool Cable and Feeder Wire Connections.

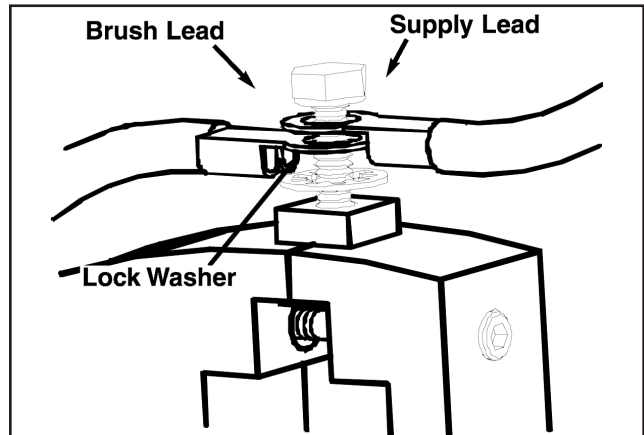

Figure 13-1

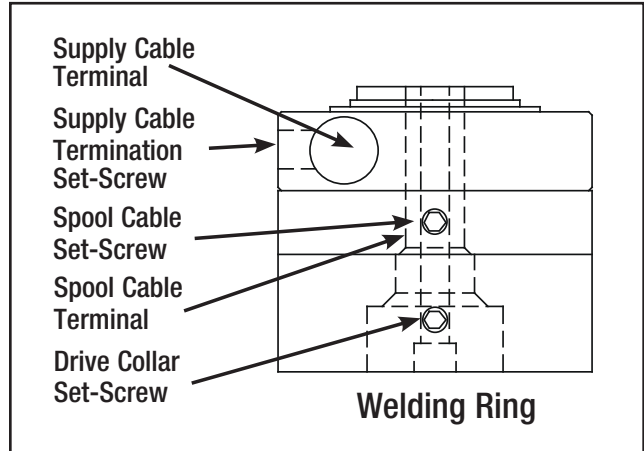

Figure 13-2

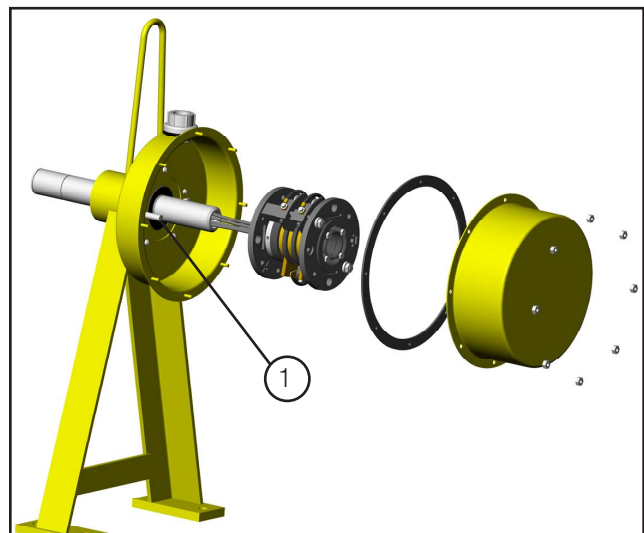

Figure 13-3 1. Drive Pin

SECTION 3 - INSTALLATION

Electrical Connections

Electrical Warnings

Electrical connections are determined by the requirements of the application and the configuration of the reel.

All electrical work should be performed by a qualified electrician.

Factory installed cable is wired with ring one (the ring closest to the drive collar) designated as ground, wired with the green cable conductor.

A continuity check should be performed prior to energizing the reel to verify electrical connections.

Spool Cable Connections

See Cable Installation Section for information on connecting the cable from the spool to the slip ring.

Supply Cable Connections

Supply cable connections are made to the brush leads of the slip ring using crimp ring connectors.

Connections made at the slip ring require adequate clearance.

Spring Tension Adjustment

Spring Tension Warnings

More demanding applications may require spring tension adjustments for proper cable retraction.

WARNING: Do not allow cable to retract without restraining the retraction speed. Walk the cable back to the reel. The retraction speed should not exceed 150 ft / min (approximately 1.7 mi / hr).

Spring Cycling

The spring should be cycled after mounting but before terminating the free end to assure that the cable will retract properly and operate under the correct tension.

This is accomplished by pulling the cable out the required distance and allowing it to rewind. This procedure should be performed five to ten (5-10) times.

Spring Pre-Tensioning

The proper pre-tensioning required for effective operation varies by cable diameter and cable weight. Trial and error is the most effective means of setting the proper spring pre-tension. Pre-tensioning is achieved by pre-loading the spring with setup turns (reel revolutions).

Pre-tensioning is not required on the 3200, 3600 Series Cable Reels prior to termination. However, pre-tension must be applied to operation; a minimum of two turns for each spring in order to avoid premature spring failure. See **Figure 14-1**.

Adjusting Spring Tension

Set-up turns can be installed on the 3200, 3600 Series Cable Reels after installation of the reel and termination of the cable ends. Spring tension should be adjusted so that the cable reel retracts the cable through the entire travel length and at the desired travel speed.

To add tension to the cable reel use a 15/16 wrench or socket and turn the shaft on the end of the spring motor(s). Rotate the shaft in the direction that causes the motor housing to rotate in the same direction as the spool would rotate to retract the cable.

Watch the counter, mounted on the tail end of each motor, to read the number of turns added to the spring. It will take 32 turns of the input shaft to install 1 turn on the spring. On units equipped with two spring motors only apply one turn to each motor at a time. Most reels are sized to work with 2 set-up turns per spring in each motor however trial and error is the best means to determine the total number of set-up turns required in your application. Use caution not to apply too many set-up turns. This will result in excessive tension on the cable. There should be no less than two turns left on each spring motor when reel is paid out all the way. Consult factory for the maximum number of set-up turns allowed on your reel model number.

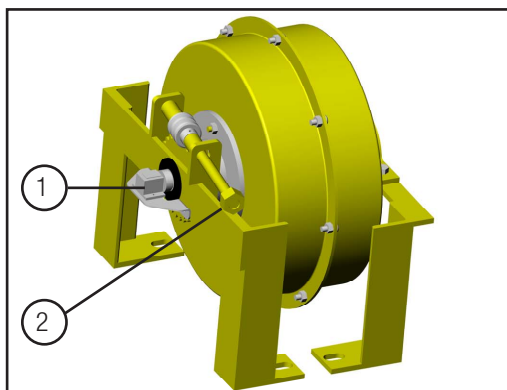

Figure 14-1
1. Counter
2. Adjusting Shaft

SECTION 4 - OPERATION

- Do not exceed the voltage or ampere rating of the cable. Do not exceed the voltage or ampere rating of the reel. Overheating, fire, damage to equipment or personal injury could result. Do not allow cable to retract without restraining the retraction speed.
- Operate the reel within the cable size and length and spring tensioning limits for which it was intended.
- Two wraps of cable should remain on the reel at maximum extension to avoid excessive tension on the cable entrance watertight and slip ring terminations.
- The spring should not be wound to the last two turns at maximum payout. This prevents over-stressing the spring(s), thus reducing it's life or damaging the reel.
- Keep the reel and cable clean to avoid excessive wear and damage.
- Arrange for maintenance service if damage is found on the cable or reel.
- To maximize spring life, cable should be fully retracted when not in use.

SECTION 5 - MAINTENANCE

Maintenance Warnings

- Be sure the power is off for maintenance.
- Follow lock-out/tag-out procedures as outlined in OSHA section 1910.147

Lubrication

- All springs and bearings are lubricated for life at the factory. Additional lubrication should not be required.
- Do not apply any lubricants or solvent cleaning agents to the slip ring, brush or insulator surfaces.
- Inspect the ring surface for dirt, oxidation, or other contaminants. A properly operating ring will have a film that appears burnished in color with a darker surrounding color where the brushes track. If the ring requires cleaning, order Slip Ring Polishing Kit #41286.

Inspections

- Check the reel every 200-400 operating hours for any loose or missing fasteners. Tighten or replace as necessary.
- The slip ring assembly should be checked periodically as follows:
 - Clean and remove any accumulated dust or dirt from the slip ring housing area.
 - Check all brush and ring surfaces in the slip ring assembly and remove any accumulated dust.
 - Brushes should be centered on the slip rings and brush springs should be seated in the slot on top of the brush. Terminal screw connections should be tight.
 - Replace Brushes when the brush spring is within 0.09" of the ring insulator.

Spring Motor Replacement

1. Carefully adjust reel to the fully retracted position.
2. Take note of the counter reading on the faulty spring motor. Remove all set-up turns from faulty spring motor by turning input shaft on the tail end of the motor in the direction that rotates the motor housing in the direction that the spool would rotate to pay the cable out. This will cause the counter to reduce in numbers. Adjust until all spring tension is removed from the motor.
3. Remove the (4) 1/2-13 bolts from the motor mounting legs and slide motor straight back away from frame. This will disengage the spring motor shaft from the sprocket stub shaft.
4. Set new motor on frame and slide forward. Align the tang in the motor shaft to the slot in the sprocket shaft and slide motor into place. Bolt motor down with the four (4) 1/2-13 bolts removed from the old motor.
5. If it is known that the tension was never changed from the initial installation, reset the set-up turns to the same number as read from the old motor. If tension was changed during the life of the reel follow procedure to adjust reel from scratch.

SECTION 5 - MAINTENANCE

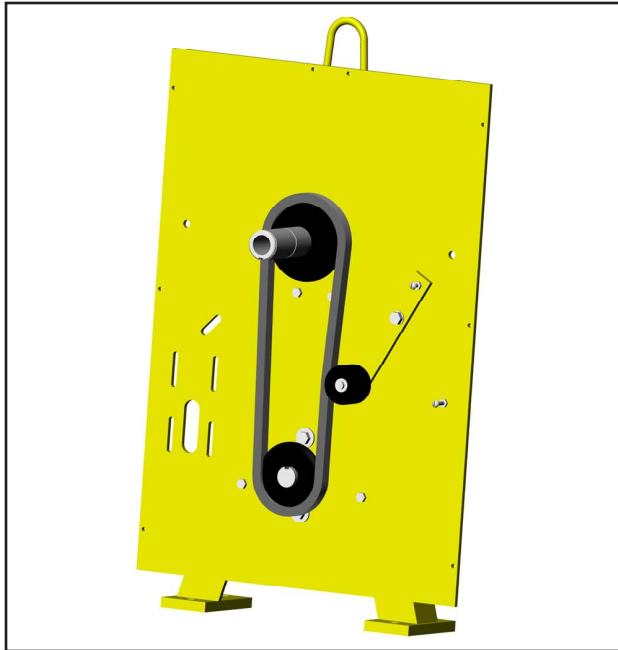

Figure 17-1 Single Motor Chain Configuration

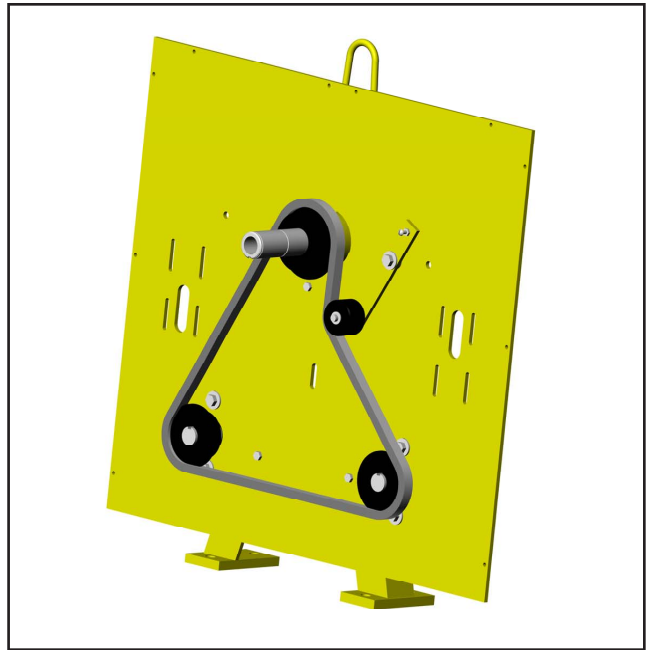

Figure 17-2 Dual Motor Mount

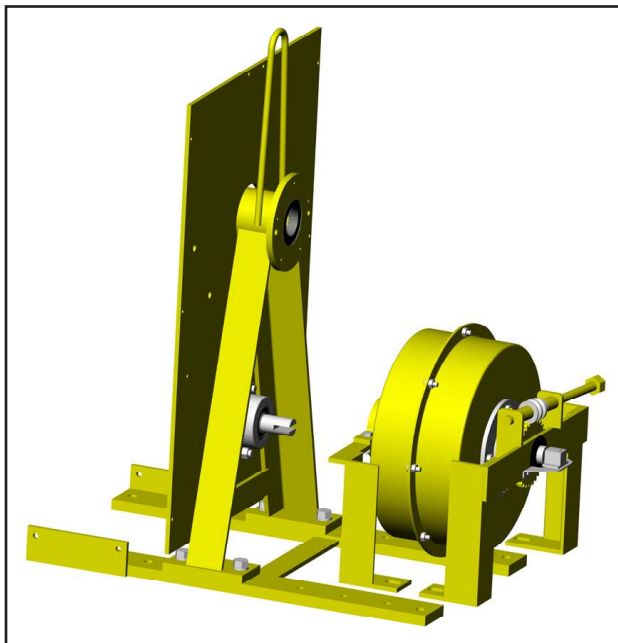

Figure 17-3 Single Motor Mount

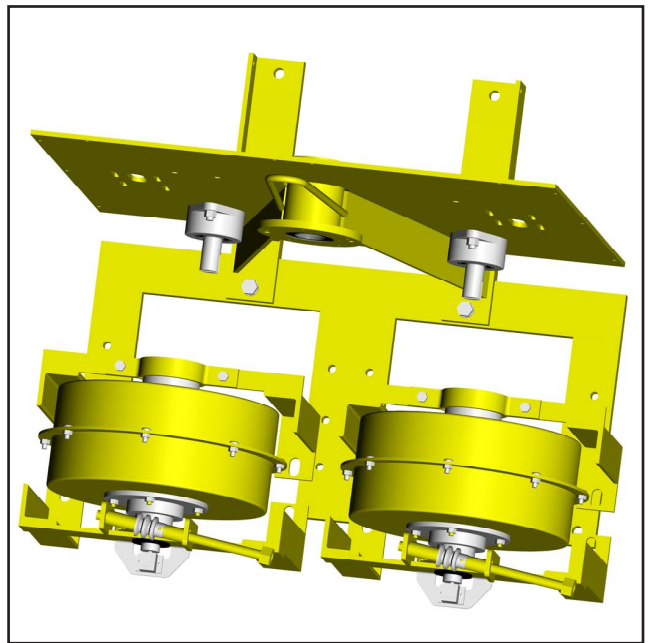

Figure 17-4 Dual Motor Mount

SECTION 6 - REPLACEMENT PARTS

R-Series Slip Rings for 3200, 3600 Series Cable Reels

In order to get the correct replacement slip ring parts for your 3200, 3600 Series Cable reel, you must first determine which slip ring is in the reel. To do this use the following steps:

1. Determine the bore size of the slip ring using method described below.
2. Look at the tag located on the frame of the reel to determine the amperage and voltage ratings of the slip ring.
3. Use the chart below to determine the appropriate replacement component.



Slip Ring Bore Size	Amp / Volt Rating	Brush Holders		Brushes	
		Single	Double	Single	Double
1.5"	35 AMP / 600V	02801	02808	30068A	30068A (x2)
1.5"	75 AMP / 600V	02802	02809	30069A	30069A (x2)
1.5"	110 AMP / 600V	02803	02810	02840	02840 (x2)
1.5"	150 AMP / 600V	02804	02811	02841	02841 (x2)
2.5"	225 AMP / 600V	02805	02805 (x2)	02847	02847 (x2)
2.5"	300 AMP / 600V	02806	02806 (x2)	02848	02848 (x2)
2.5"	200 AMP / 600V	DRA3-20A-2500		Brushes and Holders are sold as a single unit in this range	
2.5"	400 AMP / 600V	DRA3-20A-2500 (x2)			
2.5"	600 AMP / 600V	DRA3-20A-2500 (x3)			
2.5"	35 AMP / 600V	02801	02808	30068B	30068B (x2)
2.5"	75 AMP / 600V	02802	02809	30069B	30069B (x2)
2.5"	110 AMP / 600V	02803	02810	02845	02845 (x2)
2.5"	150 AMP / 600V	02804	02811	02846	02846 (x2)

To determine the bore size, measure the diameter of the slip ring enclosure.

A 1.5" bore slip ring will have an enclosure with a diameter of 11 5/8"

A 2.5" bore slip ring will have an enclosure with a diameter of 17 7/8"

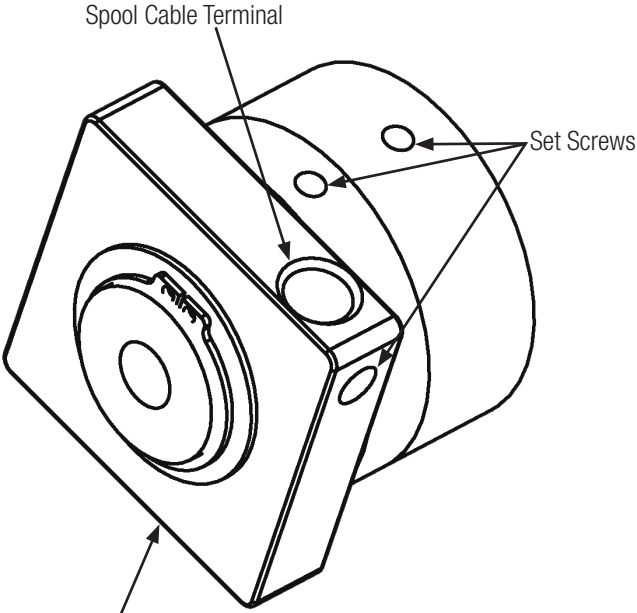
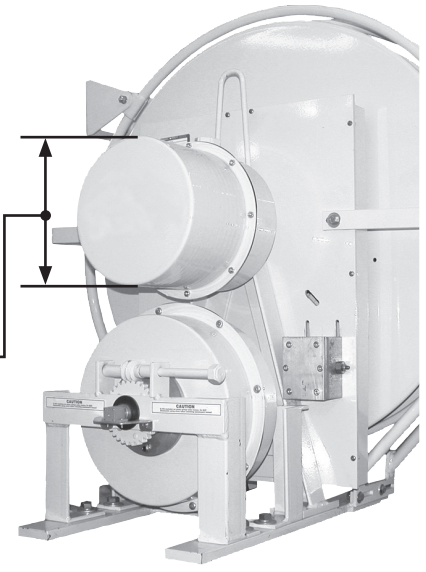

Welding Reel Ring Part No: 41190

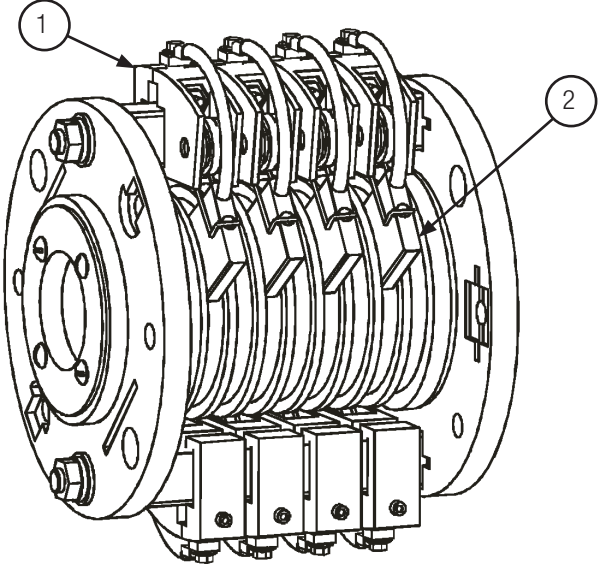

SECTION 6 - REPLACEMENT PARTS

Spring Reel Descriptive Numbering System for 3200, 3600 Series Cable Reels

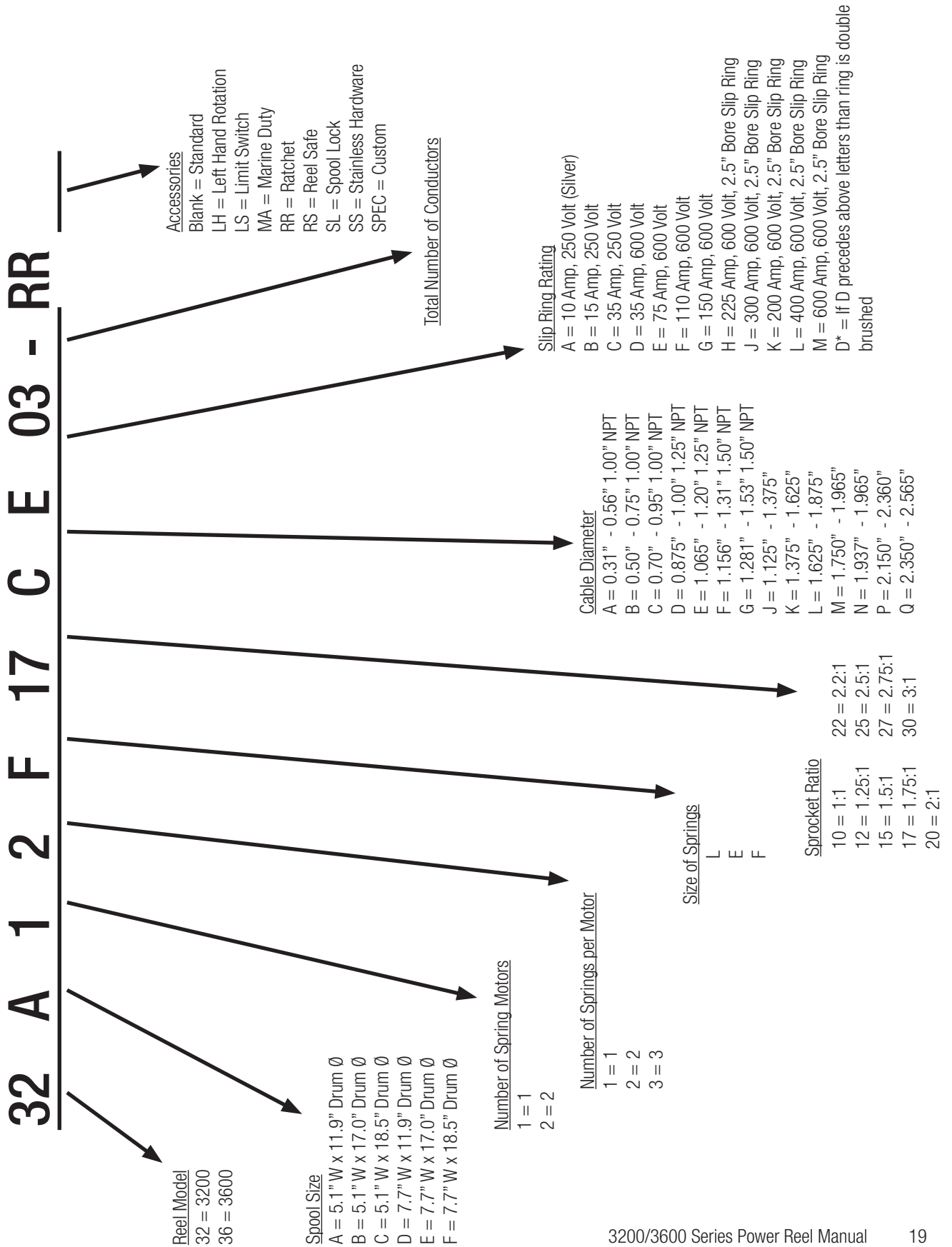

SECTION 7 - TROUBLESHOOTING

PROBLEM	POSSIBLE CAUSE	SOLUTION
Reel will not retract cable but has some tension.	<ol style="list-style-type: none"> 1) Improper pretension 2) Incorrect reel for application (lift vs. stretch). 3) Improper cable or cable length installed. 	<ol style="list-style-type: none"> 1) See Tension Adjustment section. 2) Quantify application vs. reel selection. 3) Install correct cable type and length.
Reel does not have spring tension.	<ol style="list-style-type: none"> 1) Broken spring. *Quantify application to prevent reoccurrence. 	<ol style="list-style-type: none"> 1) Replace spring motor.
Ratchet will not engage.	<ol style="list-style-type: none"> 1) Broken ratchet pawl spring. 	<ol style="list-style-type: none"> 1) Replace ratchet pawl spring.
Ratchet will not disengage.	<ol style="list-style-type: none"> 1) Over-extension of reel. 	<ol style="list-style-type: none"> 1) Manually rotate reel spool to disengage ratchet. To prevent lockup, two wraps of cable should remain on spool at all times.
Cable wraps improperly (uneven wrapping, wraps above or jumps flange).	<ol style="list-style-type: none"> 1) Reel mounting not level. 2) Cable retraction rate too high. 3) Cable guide out of adjustment. 	<ol style="list-style-type: none"> 1) Mount reel on level surface. 2) Maintain steady retraction rate. 3) Properly adjust cable guide.
Cable twisting or knotting.	<ol style="list-style-type: none"> 1) Improperly installed cable. 2) Cable rubbing on or bending around fixed object. 3) Excessive spring tension. 4) Inadequate anchoring of cable. 	<ol style="list-style-type: none"> 1) See Cable Install section on IOM. 2) Check roller guide for function and cable pay out path. 3) Quantify application vs. reel selection. Also check pretension. 4) Adjust anchoring method. ie. add strain relief.
Open or intermittent circuit.	<ol style="list-style-type: none"> 1) Inadequate connection. 2) Brush loses contact with slip ring. 3) Cable defective. 	<ol style="list-style-type: none"> 1) Check all termination points. 2) Check brush wear, spring tension & alignment. 3) Perform continuity check on cable.
Circuit trips and/or Pitted, burned rings or brushes.	<ol style="list-style-type: none"> 1) Inadequate amp rating of reel. 	<ol style="list-style-type: none"> 1) Quantify application requirements vs. reel & cable rating.
Circuit arcing	<ol style="list-style-type: none"> 1) Amp or voltage above rating of reel. 2) Excessive carbon dust accumulation. 3) Water or moisture in slip ring. 	<ol style="list-style-type: none"> 1) Quantify application requirements vs. reel & cable rating. 2) Clean dust from inside slip ring. 3) Check gasket seal. 4) Replace brush spring.
Spring failing prematurely.	<ol style="list-style-type: none"> 1) Reel may not have been setup with adequate set up turns. 	<ol style="list-style-type: none"> 1) When the reel is fully retracted, ensure a minimum of two turns per spring.



www.conductix.us

USA / LATIN AMERICA

10102 F Street
Omaha, NE 68127

Customer Support
Phone +1-800-521-4888

Phone +1-402-339-9300
Fax +1-402-339-9627

info.us@conductix.com
latinamerica@conductix.com

CANADA

18450 J.A. Bombardier
Mirabel, QC J7J 0H5

Customer Support
Phone +1-800-667-2487

Phone +1-450-565-9900
Fax +1-450-851-8591

info.ca@conductix.com

MÉXICO

Calle Treviño 983-C
Zona Centro
Apodaca, NL México 66600

Customer Support
Phone (+52 81) 1090 9519
(+52 81) 1090 9025
(+52 81) 1090 9013

Fax (+52 81) 1090 9014

info.mx@conductix.com

BRAZIL

Rua Luiz Pionti, 110
Vila Progresso
Itu, São Paulo, Brasil
CEP: 13313-534

Customer Support
Phone (+55 11) 4813 7330

Fax (+55 11) 4813 7357

info.br@conductix.com

Contact USA for our Global Sales Offices

