

Hose Reel Manual

Series 1400

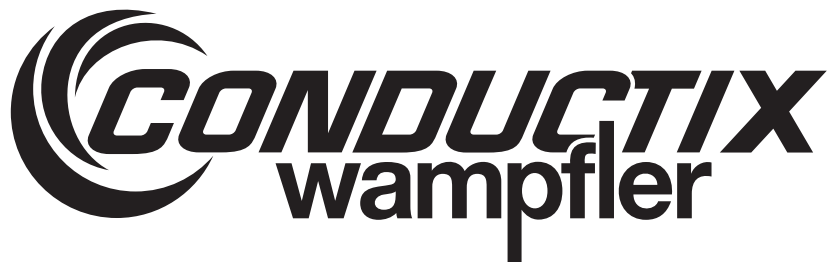
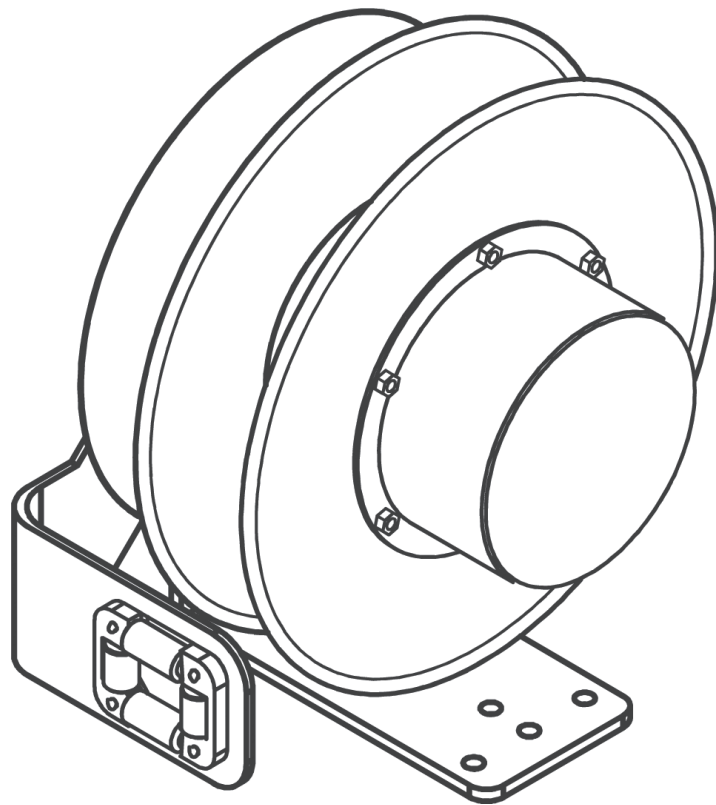

CONDUCTIX INCORPORATED

The technical data and images which appear in this manual are for informational purposes only. **NO WARRANTIES, EXPRESS OR IMPLIED, INCLUDING WARRANTIES OF MERCHANTABILITY OR FITNESS FOR A PARTICULAR PURPOSE, ARE CREATED BY THE DESCRIPTIONS AND DEPICTIONS OF THE PRODUCTS SHOWN IN THIS MANUAL.** Conductix makes no warranty (and assumes no liability) as to function of equipment or operation of systems built according to customer design or of the ability of any of its products to interface, operate or function with any portions of customer systems not provided by Conductix.

Seller agrees to repair or exchange the goods sold hereunder necessitated by reason of defective workmanship and material discovered and reported to Seller within one year after shipment of such goods to Buyer.

Except where the nature of the defect is such that it is appropriate, in Seller's judgment, to effect repairs on site, Seller's obligation hereunder to remedy defects shall be limited to repairing or replacing (at Seller's option) FOB point of original shipment by Seller, any part returned to Seller at the risk and cost of Buyer. Defective parts replaced by Seller shall become the property of Seller.

Seller shall only be obligated to make such repair or replacement if the goods have been used by Buyer only in service recommended by Seller and altered only as authorized by Seller. Seller is not responsible for defects which arise from improper installation, neglect, or improper use or from normal wear and tear.

Additionally, Seller's obligation shall be limited by the manufacturer's warranty (and is not further warranted by Seller) for all parts procured from others according to published data, specifications or performance information not designed by or for Seller.

Seller further agrees to replace or at Seller's option to provide a refund of the sales price of any goods that do not conform to applicable specifications or which differ from that agreed to be supplied which non-conformity is discovered and forthwith reported to Seller within thirty (30) days after shipment to the Buyer. Seller's obligation to replace or refund the purchase price for non-conforming goods shall arise once Buyer returns such goods FOB point of original shipment by Seller at the risk and cost of Buyer. Goods replaced by Seller shall become the property of Seller.

There is no guarantee or warranty as to anything made or sold by Seller, or any services performed, except as to title and freedom from encumbrances and, except as herein expressly stated and particularly, and without limiting the foregoing, **there is no guarantee or warranty, express or implied, of merchantability or of fitness for any particular purpose or against claim of infringement or the like.**

Seller makes no warranty (and assumes no liability) as to function of equipment or operation of systems built to Buyer's design or of the ability of any goods to interface, operate or function with any portions of Buyer's system not provided by Seller.

Seller's liability on any claim, whether in contract, tort (including negligence), or otherwise, for any loss or damage arising out of, connected with, or resulting from the manufacture, sale, delivery, resale, repair, replacement or use of any products or services shall in no case exceed the price paid for the product or services or any part thereof which give rise to the claim. In no event shall Seller be liable for consequential, special, incidental or other damages, nor shall Seller be liable in respect of personal injury or damage to property not the subject matter hereof unless attributable to gross misconduct of Seller, which shall mean an act or omission by Seller demonstrating reckless disregard of the foreseeable consequences thereof.

Seller is not responsible for incorrect choice of models or where products are used in excess of their rated and recommended capacities and design functions or under abnormal conditions. Seller assumes no liability for loss of time, damage or injuries to property or persons resulting from the use of Seller's products. Buyer shall hold Seller harmless from all liability, claims, suits and expenses in connection with loss or damage resulting from operation of products or utilization of services, respectively, of Seller and shall defend any suit or action which might arise there from in Buyer's name - provided that Seller shall have the right to elect to defend any such suit or action for the account of Buyer. The foregoing shall be the exclusive remedies of the Buyer and all persons and entities claiming through the Buyer.

INDEX

1.0 Safety

- 1.1 Pressure Warnings
- 1.2 Operational Warnings
- 1.3 Maintenance Warnings
- 1.4 Specifications and Listings
- 1.5 Pressure and Temperature Rating
- 1.6 Labels and Markings

2.0 Installation

- 2.1 Application Types
- 2.2 Mounting
- 2.3 Roller Guides
- 2.4 Ratchet
- 2.5 Hose Installation and Replacement
- 2.6 Spring Tension Adjustment

3.0 Operation

4.0 Maintenance

- 4.1 Maintenance Warning
- 4.2 Lubrication
- 4.3 Inspections
- 4.4 Swivel Joint Assembly Replacement
- 4.5 Spring Motor Replacement

5.0 Troubleshooting

6.0 Replacement Parts

- 6.1 Part Descriptions

RECORD

The catalog number of the reel and the serial number of the reel are required when ordering replacement parts or discussing the reel with the factory. Please record this information now in the spaces provided below.

CATALOG NO. OF REEL: _____

SERIAL NO: _____

DATE INSTALLED: _____

BASIC COMPONENT IDENTIFICATION

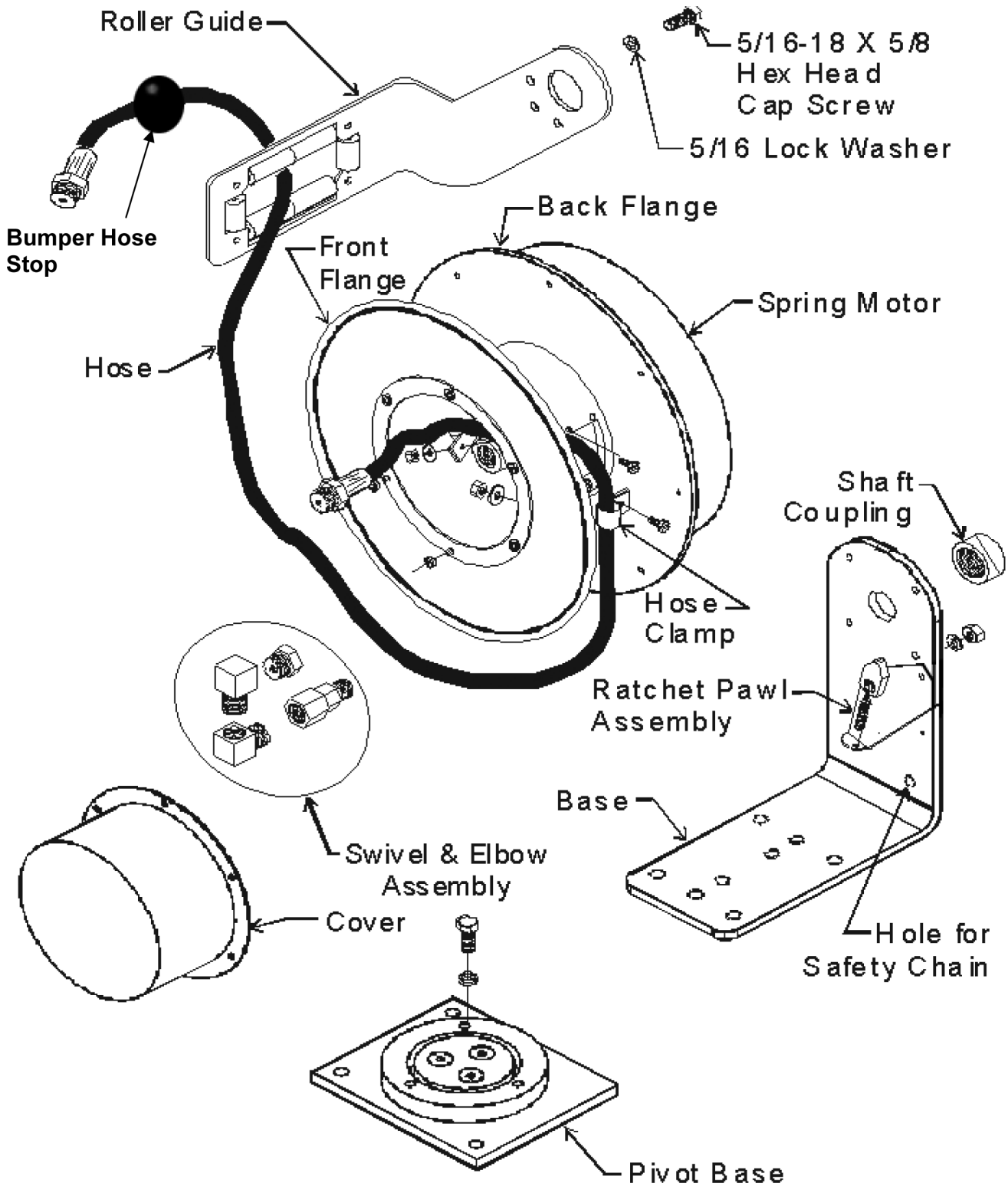

1.0 SAFETY

1.1 Pressure Warnings

- 1.1.1 This equipment should be properly installed before use in accordance with local codes and ordinances.
- 1.1.2 The pressure from the hose reel should be disconnected from the hose reel before any service functions are performed.
- 1.1.3 This hose reel must not be used for pressure greater than the rating listed on the label. See Section 1.5 for Pressure & Temperature Ratings.

1.2 Operational Warnings

- 1.2.1 Exercise care when handling the hose reel during normal operation. This hose reel has a rotating spool powered by springs under tension.
- 1.2.2 Do not use hose different from that for which the reel is intended. Changes in diameter, weight per foot, length of hose or flexibility will affect the operation of the reel.
- 1.2.3 Mounting hardware and fasteners should be installed to maintain tightness under vibration and checked periodically to ensure tightness.
- 1.2.4 Overhead installation mountings should be such that the reel is not supported by bolts in tension. A safety chain or cable is strongly recommended to minimize damage and/or possible injury in the event of mounting failure.

1.3 Maintenance Warnings

- 1.3.1 **WARNING:** Modification of this equipment may cause excessive wear and will void the warranty. Contact the manufacturer regarding changes or modifications of equipment which could affect reliability or safety.
- 1.3.2 **DO NOT DISASSEMBLE THE SPRING MOTOR FOR ANY REASON.** Serious personal injury could result. This hose reel is equipped with springs under tension. Contact the factory for assistance.

US: 1-800-452-0052

Canada: 1-800-667-2487

1.4 Specifications & Listings

- 1.4.1 1400 Series Hose Reel products are not certified or listed by any independent certifying or regulatory body.
- 1.4.2 The following specifications apply to all 1400 Series Hose Reels:
 - 1.4.2.1 1400 Series Hose Reels are intended for industrial use and are provided with permanent mounting means.
 - 1.4.2.2 1400 Series Hose Reels provide a 1/2 inch NPT female pipe thread for the stationary connection.
 - 1.4.2.3 1400 Series Hose Reel Spring Motors are weather-tight and self-contained.

1.5 Pressure & Temperature Rating

- 1.5.1 All Conductix 1400 Series Hose Reels with or without hose installed are rated at 300 P.S.I. Reels should not be used at pressures greater than the rating of the hose.
- 1.5.2 Installed hose is suitable for delivery of both air & water.
- 1.5.3 Operational temperature ranges for hose reels with hose delivering air are between -20°F through +150°F. Operational temperature ranges for hose reels with hose delivering water are between +32°F through +150°F. Hose Reels should not be used at temperatures below or above the rating of the hose.
- 1.5.4 The operational rating of a reel not equipped with hose is determined by the capacity of the installed hose. The pressure rating of the reel without hose must not be greater than 300 psi. Variations in the OD of higher rated hose will affect the operational capacity of the reel.

1.6 Labels & Markings

1.6.1 Hose Reels with and without Hose

- 1.6.1.1 The marking of the hose reel provided with or without hose includes the following:
 - 1.6.1.1.1 The label on the frame includes the Conductix name and logo, the product catalog number, the individual product serial number, PSI rating, description of the reel, what type and length of hose intended for use on the reel.
 - 1.6.1.1.2 The maximum pressure rating for every hose reel supplied without hose is marked on the Conductix Identification Label. Actual rating is determined by the installed hose and is not to exceed the indicated maximum rating. The pressure rating of the hose installed on reels provided without hose must be marked on the label upon installation.

2.0 INSTALLATION

2.1 Application Types

2.1.1 Stretch Applications



2.1.1.1 The hose is suspended without any intermediate support. Stretch reels generally require a line pull equal to two times the weight of the hose, which allows approximately 10% sag at full extension. On long applications where sag cannot be tolerated, it is sometimes desirable to put supports at intervals of 5 to 10 feet.

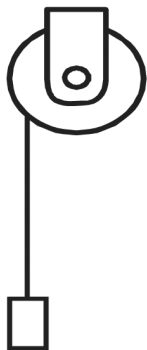

2.1.2 Lift Applications

2.1.2.1 The hose is lifted vertically in lift applications. The reel is normally designed to handle only the total weight of the hose with fluid. Some lift applications may require ball stops to control the length of hose to be retracted.

Note: Ball stops are provided with all hose reels.

2.1.3 Drag Applications

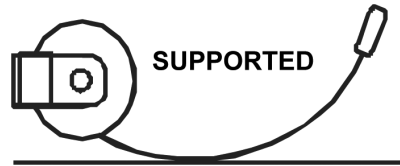

2.1.3.1 The reel is mounted on a stationary object and is required to drag the hose over the surface to the reel. The hose is supported by the ground or some type of hose tray.

2.1.4 Retrieve Applications

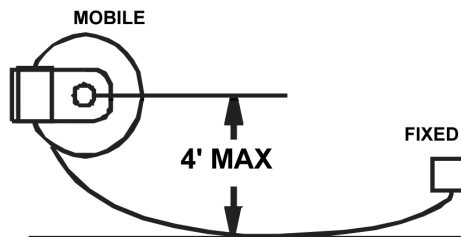

2.1.4.1 The reel is mounted on the moving object and winds up or pays out the hose as the machine approaches or moves away from the fixed end. Retrieve applications can be elevated up to 4 feet from the hose support surface.

2.2 Mounting

2.2.1 Standard Mounting

2.2.1.1 The reel is mounted by bolting the base to any flat surface which is structurally sound enough to support it and the forces of winding and unwinding the hose.

2.2.1.2 The spool drum must rotate on a horizontal axis.

2.2.1.3 The reel should be oriented so that hose extends perpendicular to the rotation of the spool. The total hose deflection should not exceed 15° to either side of the guide. Installations without a roller guide have no tolerance for deflection.

2.2.1.4 If deflection is constant to either side of the reel and operation is impaired re-mount the reel.

2.2.1.5 A Pivot Base should be used if the angle of deflection is not constant and exceeds 15° to either side. Otherwise, excessive hose wear and unreliable operation will result.

2.2.1.6 We recommend a safety chain for all overhead installations. Attach the safety chain using the 0.39 hole provided in the base. See pages 3 or 7 for location of hole for safety chain installation.

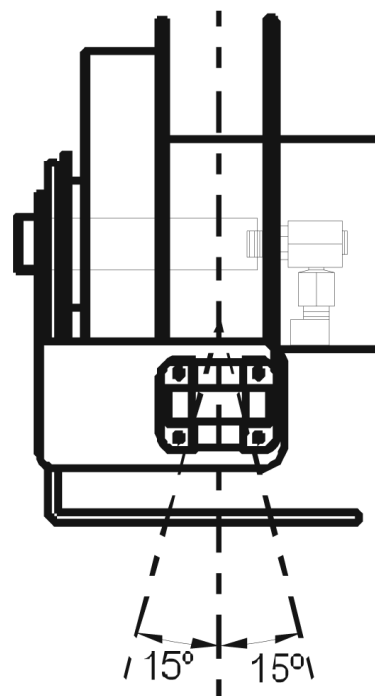

Hose Deflection w/ Guide

2.0 INSTALLATION

2.2.2 Pivot Base Mounting

- 2.2.2.1 All 1400 Series Hose Reels can be furnished with a pivot base to allow the reel to rotate and keep the extended hose perpendicular to the application.
- 2.2.2.2 The PVB Pivot Base has the ability to rotate up to 345°. Travel can be limited to 90°, 180°, or 270° by installing an additional roll pin in the appropriate available hole. This Pivot Base is not suitable for applications requiring continuous rotation.
- 2.2.2.3 A pivot base is required in carousel or loop-track applications.
- 2.2.2.4 When a pivot base is used the reel must be mounted horizontally (“ceiling” or “floor” mounted).
- 2.2.2.5 The Roller Guide should be mounted to require the hose to travel perpendicular to the axis of rotation. This will guard against the hose twisting and ensure effective swivel action from the pivot base.
- 2.2.2.6 Selection of mounting holes should be such that spool center is in line with center point of pivot base. Note: PA, PB or PC can be found in the description of the Conductix Label.

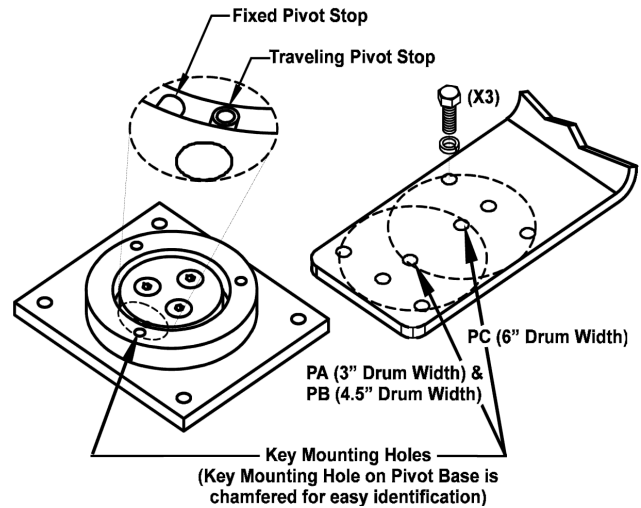

2.3 Roller Guides

- 2.3.1 All 1400 Series Hose Reel units are equipped with a roller guide (PR87). The guide's function is to center the hose on the spool and to help the reel wrap hose more evenly.
- 2.3.2 The guide must be located and secured prior to making any hose connections.
- 2.3.3 The hose should not bear against either of the spool flanges during winding as this will tend to inhibit level winding of the hose.
- 2.3.4 The guide should be secured at the best of twelve possible positions so that a minimum change of direction occurs at the guide; otherwise, hose life will be reduced and reel operation will be impaired. The illustration shows four of the twelve possible positions.
- 2.3.4.1 Mount the guide to the reel over the entrance coupling on the frame. Secure using the provided 5/16-18 hex head cap screw, including the spring-type lock washer.

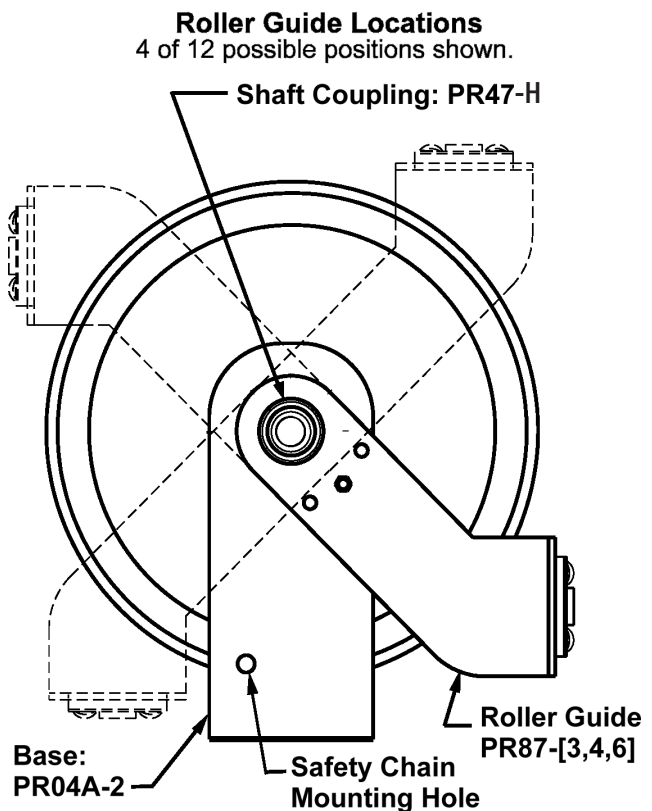

2.0 INSTALLATION

2.4 Ratchet

2.4.1 Ratchet Lock

2.4.1.1 The ratchet lock can be engaged or disengaged, depending upon the application.

2.4.2 Operation with Ratchet

2.4.2.1 The ratchet on the 1400 Series Hose Reel is spring loaded. It is designed to function in all acceptable mounting configurations.

2.4.3 Operation without Ratchet

2.4.3.1 Deactivate the ratchet by pivoting the lockbar to the lower position. To do so place a screwdriver or punch in the hole covered by the bar and push in until dimple is disengaged from hole. Push up on the end of bar with spring attached to rotate bar until dimple engages in the hole provided for the deactivated condition. This will remove the ratchet pawl from the path of the ratchet plate.

2.4.3.2 **WARNING:** Do not engage the ratchet abruptly. Sudden engagement may cause excessive shock loads to the ratchet pawl which may cause lock-up and/or breakage.

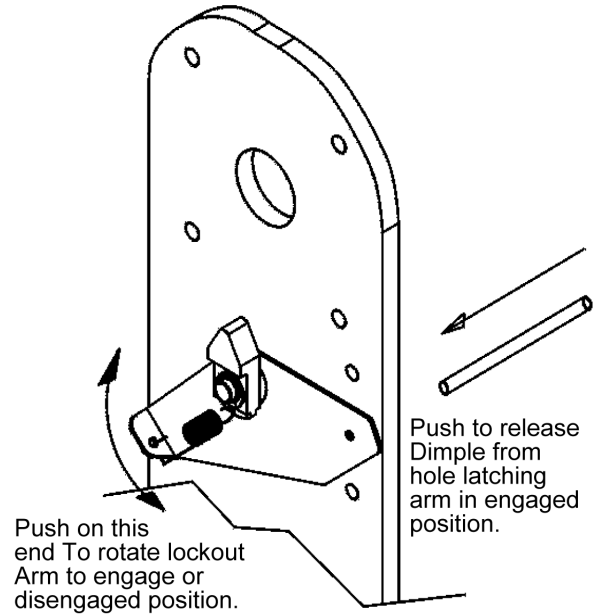

2.5 Hose Installation and Replacement

2.5.1 Hose Installation Warnings

2.5.1.1 If an existing hose is being replaced you must first remove the old hose. Replacement hose should be the same size and length as the existing hose. Any variations to existing hose specifications should be pre-approved by the factory.

2.5.1.2 Variations in inner and outer hose diameters will significantly impact reel performance. Factory specifications should be matched as closely as possible. Do not exceed any of the specifications listed in the hose specifications table. Contact Conductix Sales for further information.

2.5.1.3 Shut-off and relieve the fluid pressure to the reel before attempting to disconnect the hose. Disconnect all pressure as per Lock-Out/Tag-Out procedures outlined in OSHA section 1910.147.

Hose Specifications			
Hose ID	1/4"	3/8"	1/2"
HOSE OD	1/2"	41/64"	52/64"
PSI	300	300	300
NPT	1/4-18	3/8-18	1/4-14
Min. Bend Radius		6 1/4"	

2.0 INSTALLATION

2.5.2 Hose Removal

- 2.5.2.1 Remove the ball stop and or all of the spring tension on the reel. Make sure that the hose end is through the roller guide arm and back on the hose drum.
- 2.5.2.2 Remove the cover and the roller guide arm.
- 2.5.2.3 Remove the hose from the drum by looping it over the front flange.
- 2.5.2.4 Unscrew and detach the two hose clamps.

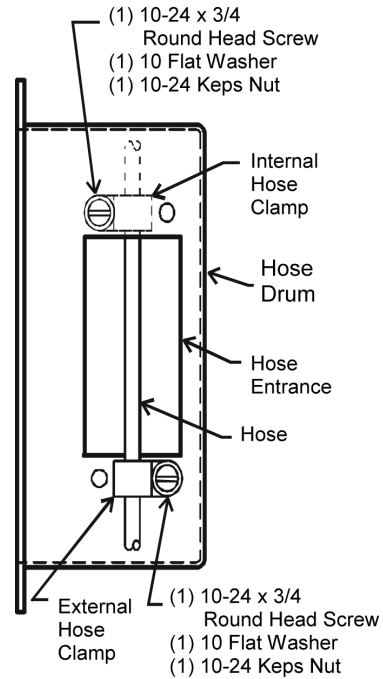

2.5.3 Hose Installation and Connections

- 2.5.3.1 Prepare the hose to be loaded onto the reel. Support the hose as shown, or lay the full length of hose out in the direction of travel. Make sure the hose will lay flat by removing any twist from the hose.
- 2.5.3.2 Apply pipe joint compound to all NPT connections and connect the hose to the elbow assembly. Thread the elbow assembly onto the end of the hose until hand-tight. Use the appropriate wrench to tighten two or three more full turns to secure.
- 2.5.3.3 Insert the end of the hose to be connected to the swivel assembly through the drum hose entrance. Hose should intrude 8-10 inches into the drum.

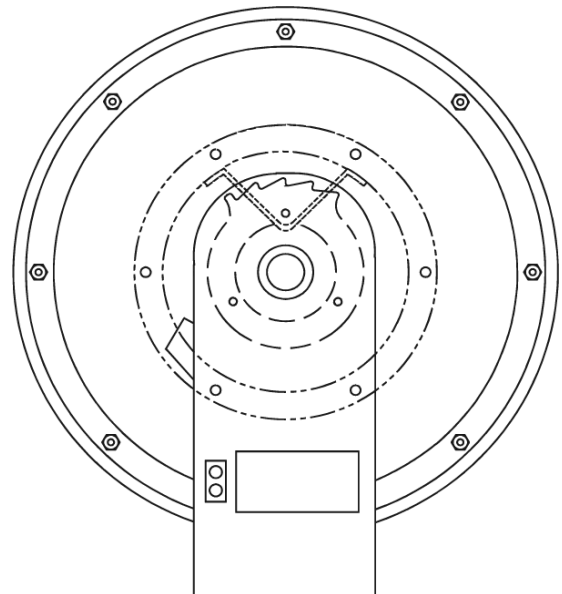
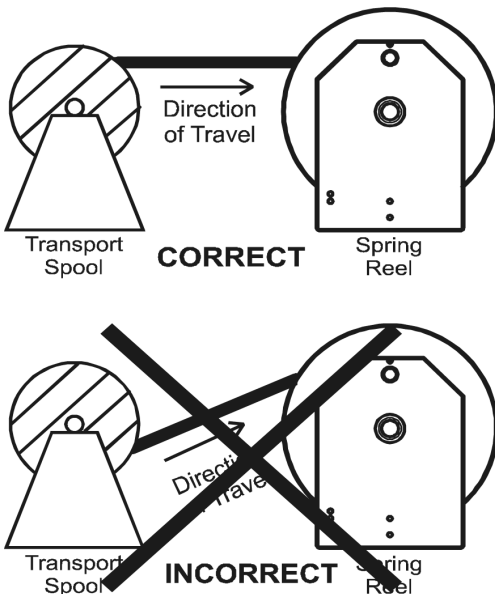

2.0 INSTALLATION

- 2.5.3.4 Attach the hose and elbow assembly into the end of the swivel until hand tight. Use the appropriate tools to tighten two to three more full turns to secure.
- 2.5.3.5 Verify that the hose end connection to the swivel assembly is offset to the appropriate angle. See Swivel Offset Illustration below.
- 2.5.3.6 Locate the Interior Hose Clamp on the Hose and tighten using one each of the provided 10-24 x 3/4 Round Head Screws, #10 Flat Washers, the appropriately sized Hose Clamps, and 10-24 Hex Nuts. The heads of the screws must be to the outside of the drum to avoid damaging the hose.
- 2.5.3.7 Locate the Exterior Hose Clamp on the Hose and tighten using the remaining provided hardware.
- 2.5.3.8 Be sure to maintain a 180° angle between the Hose/Swivel connection and the Drum Opening, as shown in Illustration. This will maintain the minimum bend radius required by the hose.

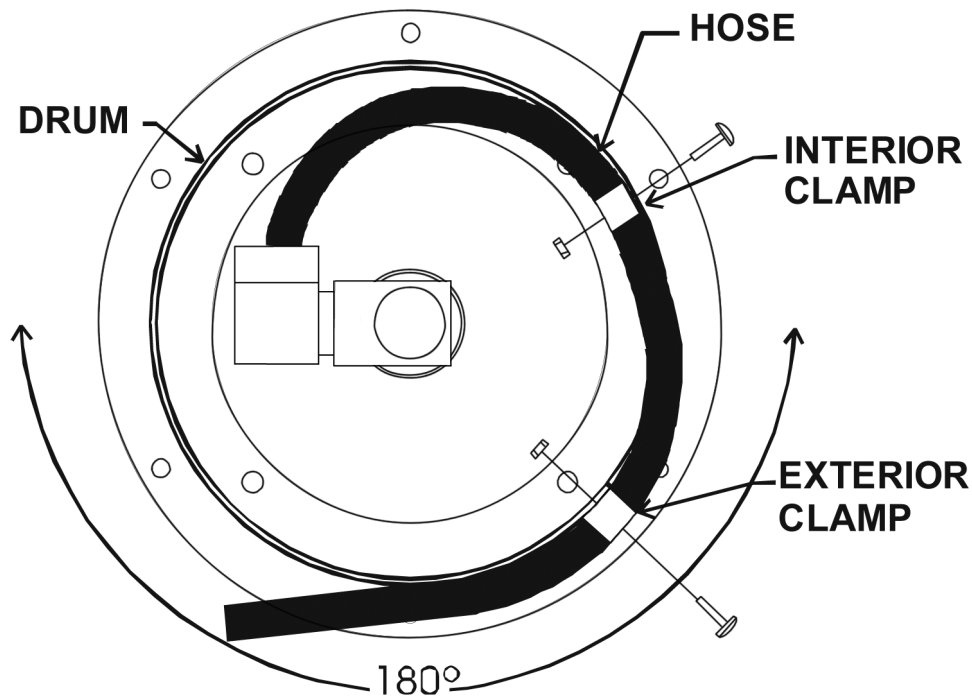

Maintain 180° Loop from Center of Opening to Swivel Inlet

- 2.5.3.9 Secure the Hose Clamp fasteners.
- 2.5.3.10 Wind the hose onto the spool by rotating the spool counterclockwise, as viewed from the cover. Reattach the roller guide arm and end cover
- 2.5.3.11 Follow Spring Tensioning Procedure to adjust the spring tension as required by the application.

2.5.4 Hose Pressurization

- 2.5.4.1 Verify all connections before pressuring the hose reel.
- 2.5.4.2 Fully extend the hose before pressurizing the line. The hose will tend to expand and may become wedged between the flanges.
- 2.5.4.3 Inspect both the reel and the hose for leaks (using soap & water for air applications) at the joints after initial pressurization.

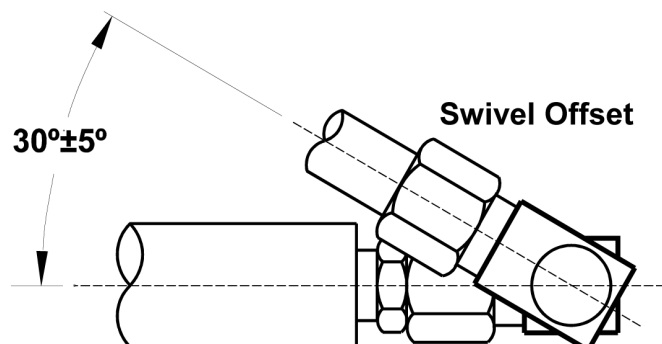

2.0 INSTALLATION

2.6 Spring Tension Adjustment

2.6.1 Spring Tension Warnings

2.6.1.1 This adjustment may require mechanical assistance in more demanding applications and installations.

2.6.1.2 **WARNING:** Do not allow hose to retract without restraining the retraction speed. Walk the hose back to the reel during the spring tension adjusting process.

2.6.2 Spring Pre-Tensioning

2.6.2.1 The proper pre-tensioning required for effective operation varies by hose diameter and hose weight. Trial and error is the most effective means of setting the proper spring pre-tension. Pre-tensioning is achieved by pre-loading the spring with setup turns (reel revolutions).

2.6.2.2 Relieve the reel of all spring tension before putting on setup turns. Grasp the end of the hose and the spool and rotate both spool and hose together in the payout direction until you feel the spring catch engage and the spring tension starts.

2.6.2.3 The number of setup turns for pre-tensioning is determined by hose diameter. Generally one to two (1-2) turns for 1/4" & 3/8" ID hose. Use three to four (3-4) turns for 1/2" ID hose.

2.6.2.4 Feed the end of the hose through the roller guide (if present) and test the Spring Tension. Pull the hose out the required distance and allow it to rewind.

2.6.3 Adjusting Spring Tension

2.6.3.1 One additional setup turn may be added to provide increased tension if the fully retracted hose is less than 30 spool revolutions. One setup turn can be removed if the torque tension is too high.

2.6.3.2 Do not add or remove setup turns on the reel after the hose has been terminated. The resulting twist may kink the hose and shorten hose life.

2.6.3.3 Disconnect the terminated end of the hose and/or remove the ball stop if applicable.

2.6.3.4 Add one wrap of hose to the spool by pulling the end of the hose through the roller guide and winding the hose around the spool. The hose should then be fed back through the roller guide.

2.6.3.5 Relocate the ball stop if applicable.

2.6.4 Spring Cycling

2.6.4.1 The spring should be cycled after mounting but before terminating the free end. This will verify the tension adjustment and assure that the hose will retract properly.

2.6.4.2 Spring Cycling is accomplished by pulling the hose out the required distance and allowing it to rewind. This procedure should be performed five to ten (5-10) times. See warning in 2.6.1.2 on this page

2.6.4.3 Secure the end of the hose using the appropriate fittings and sealant.

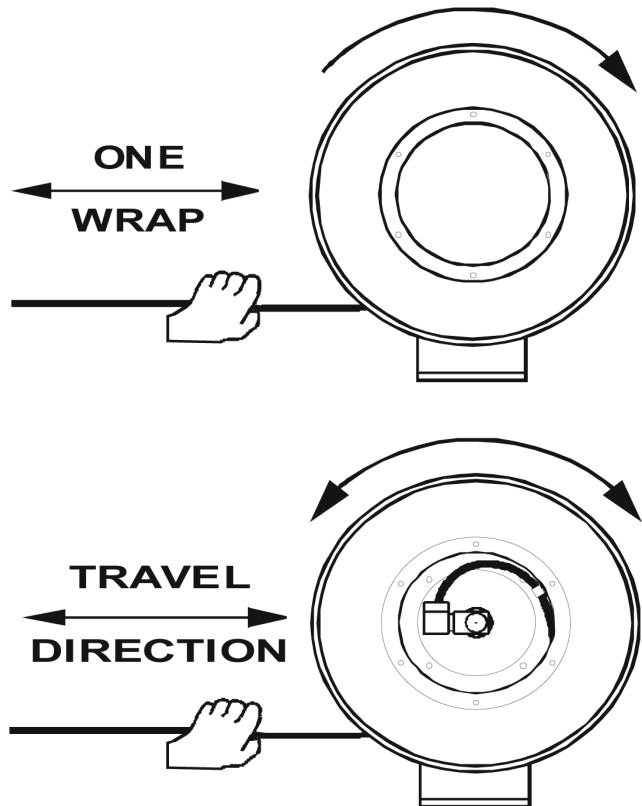

3.0 OPERATION

- 3.1 Do not exceed the pressure or temperature rating of the hose. Do not exceed the pressure or temperature rating of the reel. Pressure and temperature above the rated capacity could cause damage to equipment and personal injury could result.
- 3.2 Operate the reel within the hose size, length and spring tensioning limits for which it was intended.
 - 3.2.1 Note: Two wraps of hose should remain on the reel at maximum extension to avoid excessive tension on the hose clamps.
 - 3.2.2 The spring should not be wound to the last two turns at maximum payout to avoid over-stressing the spring, thus reducing spring life or damaging the reel. See Section 2.6.3.1 for details.
- 3.3 Keep the reel and hose clean to avoid excessive wear and damage.
- 3.4 Arrange for maintenance service if damage is found on the hose or reel.
- 3.5 Hose should be fully retracted when not in service to maximize spring life.

4.0 MAINTENANCE

4.1 Maintenance Warnings

- 4.1.1 Be sure all pressure is off for maintenance.
- 4.1.2 Follow lock-out/tag-out procedures as outlined in OSHA section 1910.147 where appropriate.

4.2 Lubrication

- 4.2.1 All springs and bearings are lubricated for life at the factory. Additional lubrication should not be required.

4.3 Inspections

- 4.3.1 Periodically check the reel for any loose or missing fasteners. Tighten or replace as necessary.

4.4 Swivel Joint Assembly Replacement

- 4.4.1 The swivel joint should be replaced, not rebuilt, if it becomes damaged.
- 4.4.2 Follow steps 2.5.2.1 through 2.5.3.4 to disconnect the hose and elbow assembly from the reel.
- 4.4.3 Separate the swivel joint from the shaft and dispose of the damaged swivel joint.
- 4.4.4 Re-assemble the reel as outlined in Section 2.5.3: Hose Installation using the replacement swivel joint.

4.0 MAINTENANCE

4.5 Spring Motor Replacement

4.5.1 Spring Motor Warnings

4.5.1.1 CAUTION: Do not open the spring motor or personal injury may result.

4.5.1.2 The spring replacement process is determined by the spring configuration and cannot be performed in the field. The entire spring motor must be replaced as a unit.

4.5.1.3 For further instructions, consult the factory.

In the USA call: 1-800-452-0052.

In Canada call: 1-800-667-2487.

4.5.2 Spring Motor Life

4.5.2.1 Spring life is determined by duty cycle and application requirements. Spring life can vary depending on operating environment, application range, and duty cycle. Actual performance and maintenance scheduling can only be determined by individual factors in the application.

4.5.3 Spring Motor Removal & Replacement

4.5.3.1 Relieve all gas/fluid pressure to the reel before beginning any maintenance or service.

4.5.3.2 Disconnect the terminated end of the hose.

4.5.3.3 Follow the steps listed in Section

4.5.3.4 Remove the elbow assembly from the shaft by using the appropriately sized wrench.

4.5.3.5 Remove the shaft coupling (PR47-H).

4.5.3.6 Remove the spring motor (PR89-H) by unscrewing the shaft from the mounting base (PR04A-2).

4.5.3.7 Remove packing material from the replacement spring motor. Attach the replacement spring motor to the mounting base.

4.5.3.8 Re-assemble the spring reel by following the previous steps in reverse order. Be sure to engage the ratchet mechanism as outlined in Section 2.4.

4.5.3.9 Adjust spring tension by following the procedure in section 2.6.

5.0 TROUBLESHOOTING

PROBLEM	POSSIBLE CAUSE	SOLUTION
Reel will not retract hose but has some tension.	<ol style="list-style-type: none"> 1) Improper pretension. 2) Incorrect reel for application (lift vs. stretch) 3) Improper hose or hose length installed. 4) Roller 'hose' guide adjustment. 5) Ratchet is engaged in constant tension application. 	<ol style="list-style-type: none"> 1) See Sec. 2.6 Spring Tension Adjustment. 2) Quantify supplication vs. reel selection. 3) Install correct hose type and length. 4) Check guide alignment (see Sec. 2.2 and 2.3) 5) Disengage (lock out) ratchet feature.
Reel does not have any spring tension.	<ol style="list-style-type: none"> 1) Broken spring. *Quantify application to prevent recurrence. 	<ol style="list-style-type: none"> 1) Replace spring motor (See Sec. 4.5)
Ratchet will not engage.	<ol style="list-style-type: none"> 1) Broken ratchet pawl spring. 2) Lock-out option arm deactivated. 	<ol style="list-style-type: none"> 1) Replace ratchet pawl spring. 2) Activate lock-out arm (See Sec. 2.4)
Ratchet will not deactivate.	<ol style="list-style-type: none"> 1) Over-extension of reel. 	<ol style="list-style-type: none"> 1a) Manually rotate reel spool to deactivate ratchet. <u>Do not</u> over-extend or adjust guide to prevent lockup when reel is over-extended. 1b) Readjust ball stop if applicable. 1c) (Preventative) Keep 2 wraps of hose on the reel.
Hose wraps improperly (uneven wrapping, wraps above or jumps flange).	<ol style="list-style-type: none"> 1) Improper hose or hose length installed. 2) Hose guide adjustment. 	<ol style="list-style-type: none"> 1) Install hose for which reel was intended. 2) Check & adjust guide alignment.
Hose twisting or knotting.	<ol style="list-style-type: none"> 1) Improperly installed hose. 2) Hose rubbing on or bending around fixed object. 3) Excessive spring tension. 4) Inadequate anchoring of hose. 	<ol style="list-style-type: none"> 1) See hose installation section of IOM. 2) Check roller guide for function and hose payout path. 3) Quantify application vs. reel selection. 4) Adjust anchoring method. i.e. add strain relief (kelloms grip)
System leak, loses or does not transfer fluids/gas.	<ol style="list-style-type: none"> 1) Faulty hose or connections. 2) Worn swivel joint. 	<ol style="list-style-type: none"> 1) Inspect and repair. 2) Replace.

6.0 REPLACEMENT PARTS

6.1 Part Descriptions

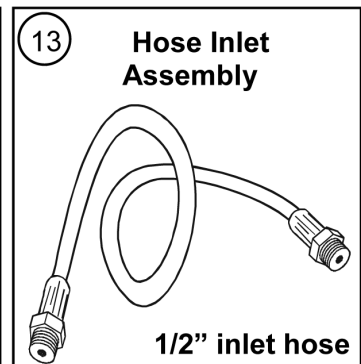
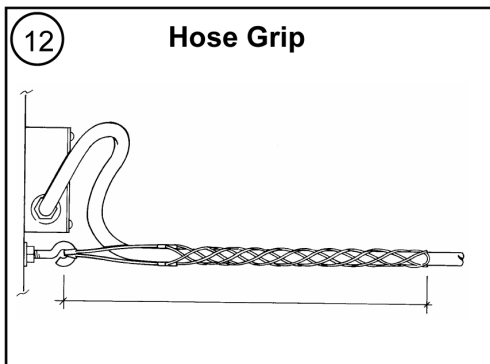
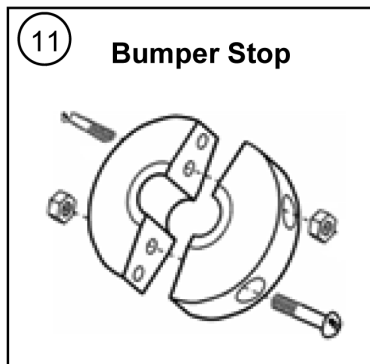
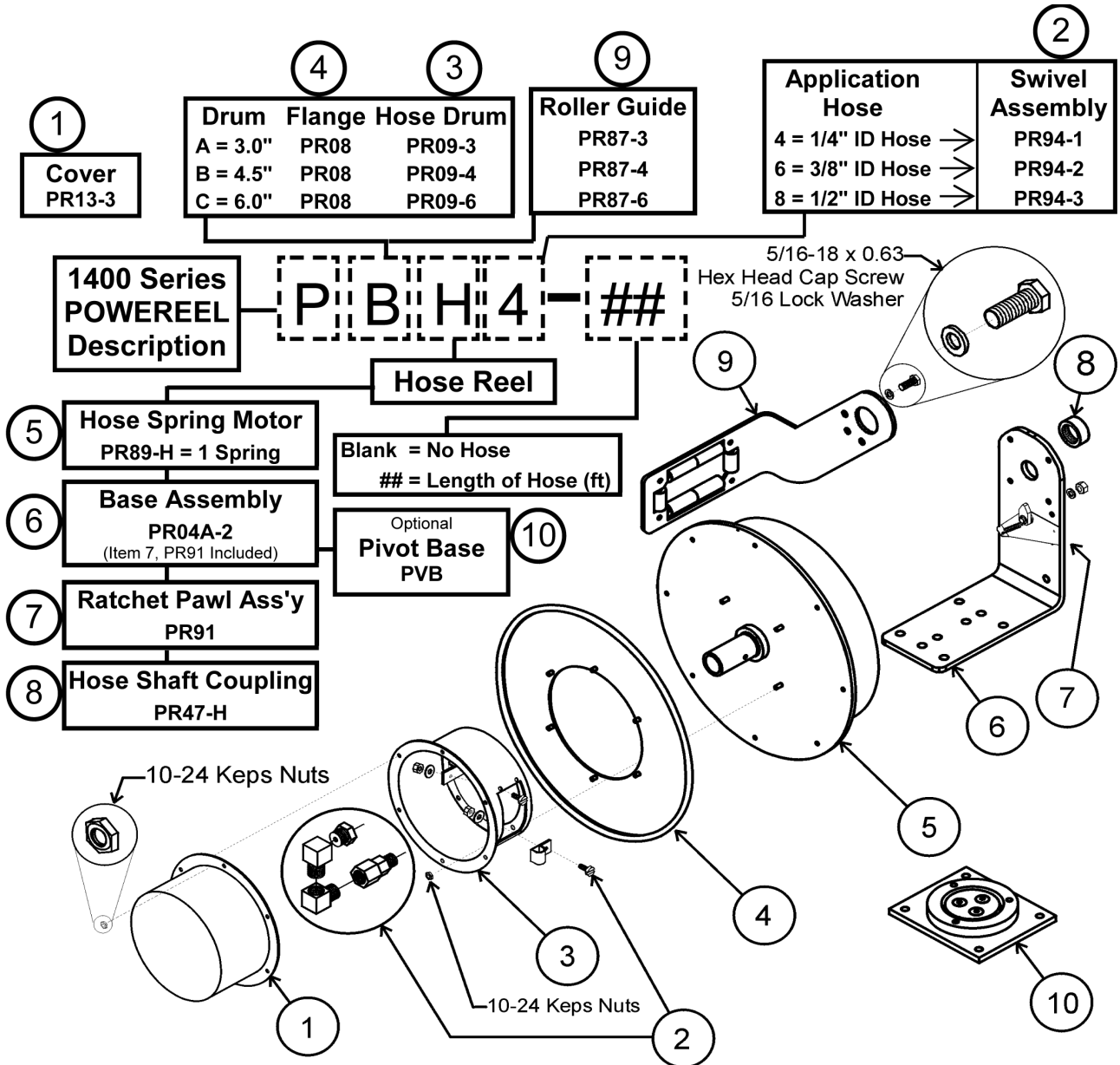

www.conductix.us

USA / LATIN AMERICA

10102 F Street
Omaha, NE 68127

Customer Support

Phone +1-800-521-4888

Phone +1-402-339-9300

Fax +1-402-339-9627

info.us@conductix.com

latinamerica@conductix.com

CANADA

1435 Norjohn Court
Unit 5
Burlington, ON L7L 0E6

Customer Support

Phone +1-800-667-2487

Phone +1-450-565-9900

Fax +1-450-851-8591

info.ca@conductix.com

MÉXICO

Calle Treviño 983-C
Zona Centro
Apodaca, NL México 66600

Customer Support

Phone (+52 81) 1090 9519

(+52 81) 1090 9025

(+52 81) 1090 9013

Fax (+52 81) 1090 9014

info.mx@conductix.com

BRAZIL

Rua Luiz Pionti, 110
Vila Progresso
Itu, São Paulo, Brasil
CEP: 13313-534

Customer Support

Phone (+55 11) 4813 7330

Fax (+55 11) 4813 7357

info.br@conductix.com

Contact us for our Global Sales Offices

