

DMX GafferReel Manual

1200 Series

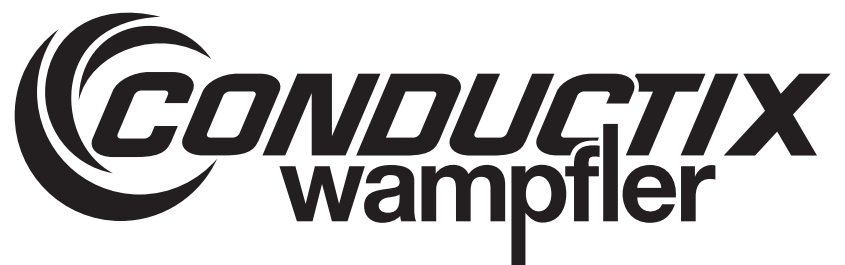
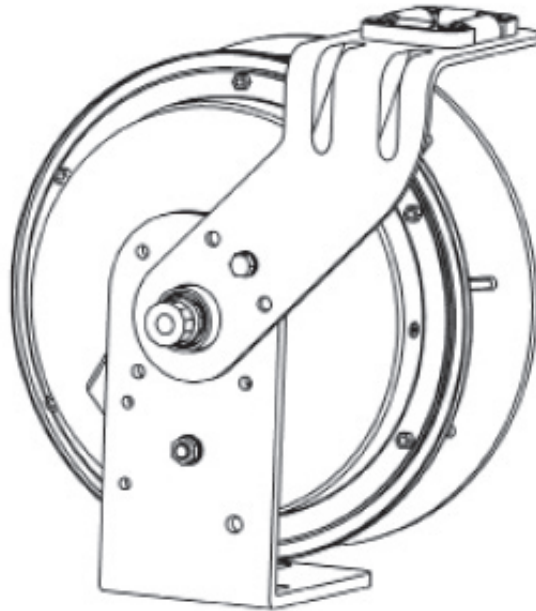

CONDUCTIX INCORPORATED

The technical data and images which appear in this manual are for informational purposes only. **NO WARRANTIES, EXPRESS OR IMPLIED, INCLUDING WARRANTIES OF MERCHANTABILITY OR FITNESS FOR A PARTICULAR PURPOSE, ARE CREATED BY THE DESCRIPTIONS AND DEPICTIONS OF THE PRODUCTS SHOWN IN THIS MANUAL.** Conductix-Wampfler makes no warranty (and assumes no liability) as to function of equipment or operation of systems built according to customer design or of the ability of any of its products to interface, operate, or function with any portions of customer systems not provided by Conductix-Wampfler.

Seller agrees to repair or exchange the goods sold hereunder necessitated by reason of defective workmanship and material discovered and reported to Seller within one year after shipment of such goods to Buyer.

Except where the nature of the defect is such that it is appropriate, in Seller's judgment, to effect repairs on site, Seller's obligation hereunder to remedy defects shall be limited to repairing or replacing (at Seller's option) FOB point of original shipment by Seller, any part returned to Seller at the risk and cost of Buyer. Defective parts replaced by Seller shall become the property of Seller.

Seller shall only be obligated to make such repair or replacement if the goods have been used by Buyer only in service recommended by Seller and altered only as authorized by Seller. Seller is not responsible for defects which arise from improper installation, neglect, or improper use or from normal wear and tear.

Additionally, Seller's obligation shall be limited by the manufacturer's warranty (and is not further warranted by Seller) for all parts procured from others according to published data, specifications or performance information not designed by or for Seller.

Seller further agrees to replace or at Seller's option to provide a refund of the sales price of any goods that do not conform to applicable specifications or which differ from that agreed to be supplied which non-conformity is discovered and forthwith reported to Seller within thirty (30) days after shipment to the Buyer. Seller's obligation to replace or refund the purchase price for non-conforming goods shall arise once Buyer returns such goods FOB point of original shipment by Seller at the risk and cost of Buyer. Goods replaced by Seller shall become the property of Seller.

There is no guarantee or warranty as to anything made or sold by Seller, or any services performed, except as to title and freedom from encumbrances and, except as herein expressly stated and particularly, and without limiting the foregoing, **there is no guarantee or warranty, express or implied, of merchantability or of fitness for any particular purpose or against claim of infringement or the like.**

Seller makes no warranty (and assumes no liability) as to function of equipment or operation of systems built to Buyer's design or of the ability of any goods to interface, operate, or function with any portions of Buyer's system not provided by Seller.

Seller's liability on any claim, whether in contract, tort (including negligence), or otherwise, for any loss or damage arising out of, connected with, or resulting from the manufacture, sale, delivery, resale, repair, replacement, or use of any products or services shall in no case exceed the price paid for the product or services or any part thereof which give rise to the claim. In no event shall Seller be liable for consequential, special, incidental, or other damages, nor shall Seller be liable in respect of personal injury or damage to property not the subject matter hereof unless attributable to gross misconduct of Seller, which shall mean an act or omission by Seller demonstrating reckless disregard of the foreseeable consequences thereof.

Seller is not responsible for incorrect choice of models or where products are used in excess of their rated and recommended capacities and design functions or under abnormal conditions. Seller assumes no liability for loss of time, damage, or injuries to property or persons resulting from the use of Seller's products. Buyer shall hold Seller harmless from all liability, claims, suits, and expenses in connection with loss or damage resulting from operation of products or utilization of services, respectively, of Seller and shall defend any suit or action which might arise there from in Buyer's name - provided that Seller shall have the right to elect to defend any such suit or action for the account of Buyer. The foregoing shall be the exclusive remedies of the Buyer and all persons and entitles claiming through the Buyer.

TABLE OF CONTENTS

SECTION 1 - SAFETY	5
Safety Information Responsibility	5
Safety Messages	5
Electrical Warnings	6
Operational Warnings	6
Maintenance Warnings	6
Rating	6
Electrical Rating	6
Labels & Marking	6
SECTION 2 - OVERVIEW	7
SECTION 3 - INSTALLATION	8
Application Types	8
Stretch Applications	8
Lift Applications	8
Drag Applications	8
Retrieve Applications	8
Mounting	8
Standard Mounting	8
Pivot Base Mounting (Optional Accessory)	9
Roller Guides	9
Ratchet	10
Cable Installation	10
Feeder Cord Connection	12
Spring Tension Adjustment	12
SECTION 4- OPERATION	13
SECTION 5 - MAINTENANCE	14
Lubrication	14
Inspections	14
Slip Ring & Feeder Cord Replacement	14
Cable Replacement	14
Spring Motor Replacement	15
SECTION 6 - TROUBLESHOOTING	16
SECTION 7 - REPLACEMENT PARTS	17

CONDUCTIX-WAMPFLER FIELD SERVICE

Need Field Service for our products? We Can Handle It!

Ask us for a quote on expert system installations, inspections, preventative maintenance, and repairs/retrofits.

As the world's largest single source manufacturer of mobile electrification products, Conductix-Wampfler has the unique ability to offer a degree of service not found anywhere else. Conductix-Wampfler's team of highly qualified service technicians and engineers have years of experience servicing our complete line of products.

We can provide:

- **Annual service contracts**
- **Installation**
- **Commissioning**
- **Installation supervision** to ensure your installers avoid common mistakes.
- **Troubleshooting** to get you up and running.
- **Pre-planned inspections** to complement your preventive maintenance program.

Call 1.800.521.4888 for further details.



SECTION 1 - SAFETY

Safety Information Responsibility

All owner, operator, and maintenance personnel must read and understand all manuals associated with this product before installation, operation, or maintenance.

The manual provides information on the recommended installation, operation, and maintenance of this product. Failure to read and follow the information provided could cause harm to yourself or others and/or cause product damage. No one should install, operate, or attempt maintenance of this product prior to familiarizing themselves with the information in this manual.

Safety Messages The following safety messages are used in this manual to alert you to specific and important safety.



CAUTION

- CAUTION indicates unsafe actions or situations that have the potential to cause injury, and/or minor equipment or property damage.



DANGER

- DANGER indicates hazards that have the potential to cause severe personal injury or death.



WARNING

- WARNING indicates unsafe actions or situations that have the potential to cause severe injury, death, and/or major equipment or property damage.

NOTE

- NOTE is used to alert you to installation, operation, programming, or maintenance information that is important, but not hazard related.

SECTION 1 - SAFETY

Electrical Warnings

Properly ground this equipment before use in accordance with both the National Electric Code and local electrical codes and ordinances.

Disconnect the electrical power from the cable reel before any service functions are performed.

Do not use this cable reel for loads greater than the current rating listed on the label and voltage greater than 250V.

Electrical wiring on the reel must be done by a qualified electrician.

Operational Warnings

Exercise care when handling the cable reel during normal operation. This cable reel has a rotating spool powered by springs under tension.

Do not allow cable to retract without restraining the retraction speed.

Do not disassemble the spring motor for any reason. Serious personal injury could result. This cable reel is equipped with springs under tension. Contact the factory for assistance:

In the US call: 1 800-521-4888

In the Canada call: 1 800-667-2487

Maintenance Warnings

Do not use cable different from that for which the reel is intended. Changes in diameter, weight per foot, length of cable or flexibility will affect the operation of the reel.

Mounting hardware and fasteners should be installed to maintain tightness under vibration and checked periodically to assure tightness.

Overhead installation mountings should be such that the reel is not suspended by bolts in tension. A safety chain or cable is strongly recommended to minimize damage and/or possible injury in the event of mounting failure.

WARNING

- Modification of this equipment may cause excessive wear and will void the warranty. Contact the manufacturer regarding changes or modifications of equipment which could affect reliability or safety.

Rating

The 1200 SERIES POWEREEL® products are built to UL/CSA NEMA 4 specifications. Reels supplied with plugs and/or attachments have a NEMA 2 rating. However 1200 series gaffer reels are not third party listed.

Electrical Rating

Reels equipped with or without cable.

Reels equipped with cable are rated and should not be used at voltages and/or amperes above the rating on the reel. Please consult factory prior to making any changes in volts and amps of cable, as a change could affect reliability or safety.

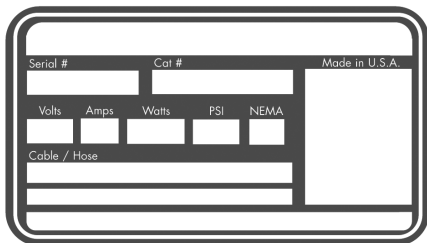

Labels & Marking

Every cable reel is marked with a label which includes the Conductix name and logo, the product catalog number, the individual product serial number, NEMA rating, Amps, Volts, Watts and Cable Footage.

The maximum cable footage, amperage and voltage rating for every cable reel supplied without cable is marked on the Conductix Identification Label. The actual cable installed should not differ from what is indicated on the Conductix label. If the cable must be different please consult the factory prior to installing the cable to ensure the change will not affect the reliability of the reel or the safety of the people working with the reel.

SECTION 2 - OVERVIEW

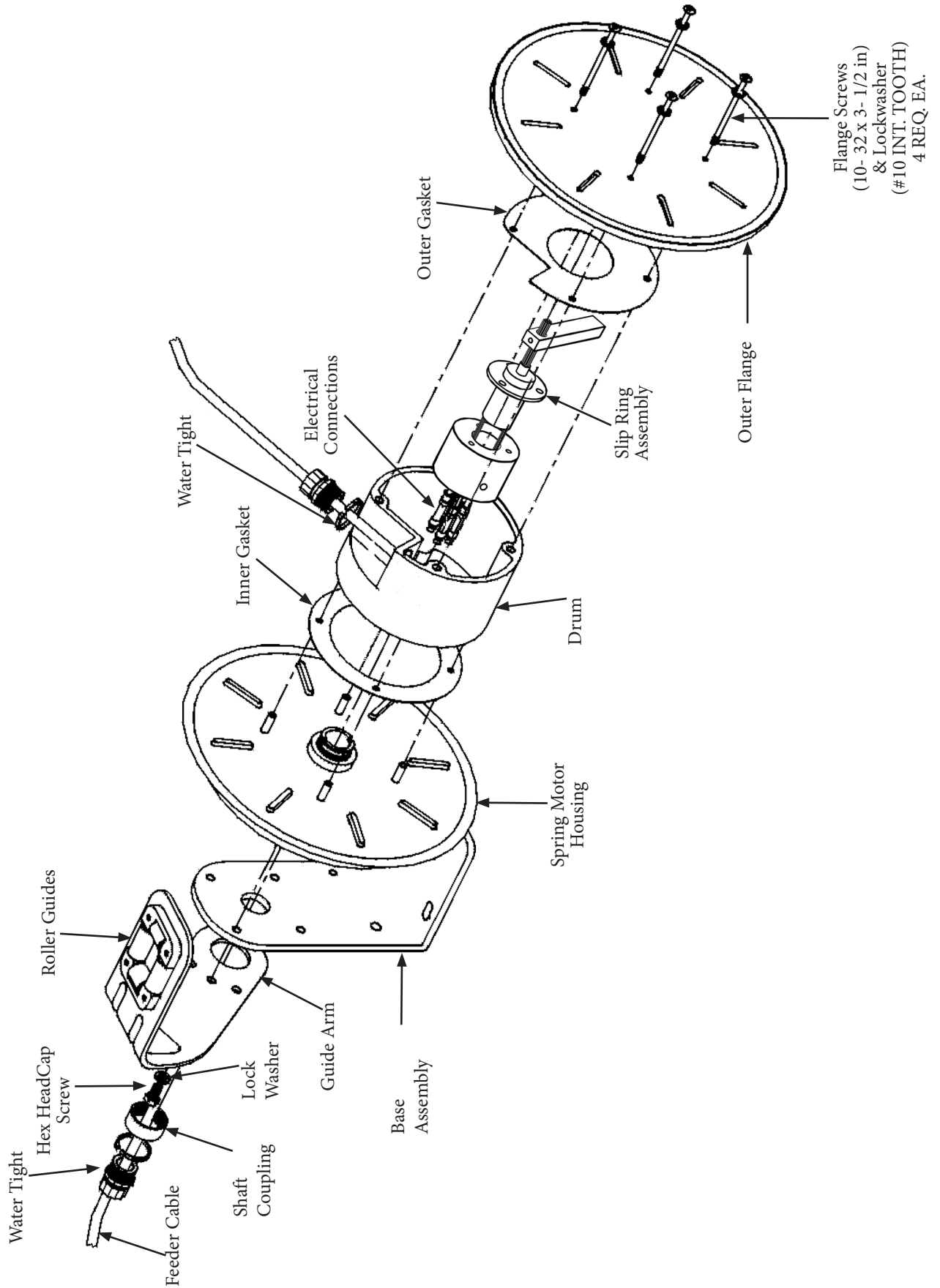

SECTION 3 - INSTALLATION

Application Types

Stretch Applications

The cable is suspended without any intermediate support. Stretch reels generally require a line pull equal to two times the weight of the cable, which allows approximately 10% sag at full extension. On long applications where sag cannot be tolerated, it is sometimes desirable to put supports at intervals of 5 to 10 feet. See **Figure 8-1**.

Reels intended for stretch applications will be supplied with a ratchet that can be disabled for constant tension.

Lift Applications

The cable is lifted vertically in lift applications. The reel is normally designed to handle only the total weight of the cable. Some lift applications may require a ball stop and ratchet to control the length of cable to be retracted. See **Figure 8-2**.

Drag Applications

The reel is mounted on a stationary object and is required to drag the cable over the surface to the reel. The cable is supported by the ground or some type of cable tray. A ball stop may be required. See **Figure 8-3**.

Retrieve Applications

The reel is mounted on the moving object and winds up or pays out the cable as the machine approaches or moves away from the fixed end. See **Figure 8-4**.

Mounting

Standard Mounting

The reel may be mounted by bolting the base to any flat surface which is structurally sound enough to support it and the forces of winding and unwinding the cable.

- The spool drum must rotate on a horizontal axis.
- The reel should be oriented so that the cable extends perpendicular to the rotation of the spool. The cable deflection should not exceed 15° to either side of the center line. See **Figure 8-5**.
- If deflection is constant to either side of the reel and operation is impaired, re-mount the reel.
- If the total angle of deflection exceeds 30° a Pivot Base should be used, otherwise excessive cable wear and unreliable operation will result.
- We recommend a safety chain for all overhead

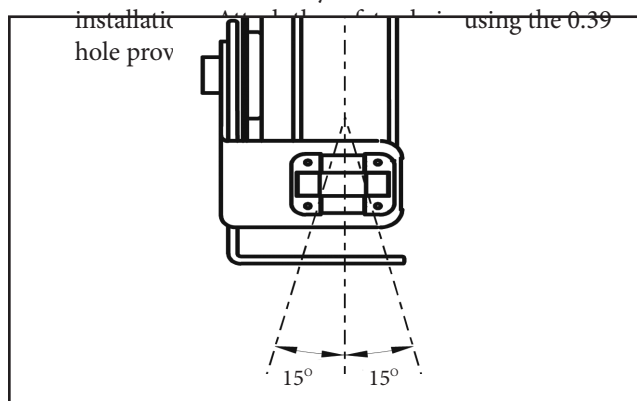

Figure 8-5 Cable Deflection with Roller Guide

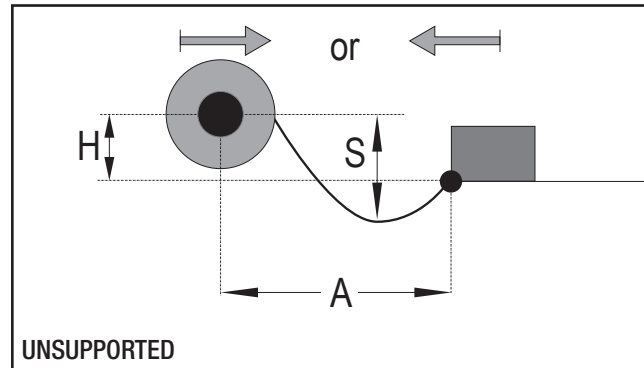

Figure 8-1 Stretch Application

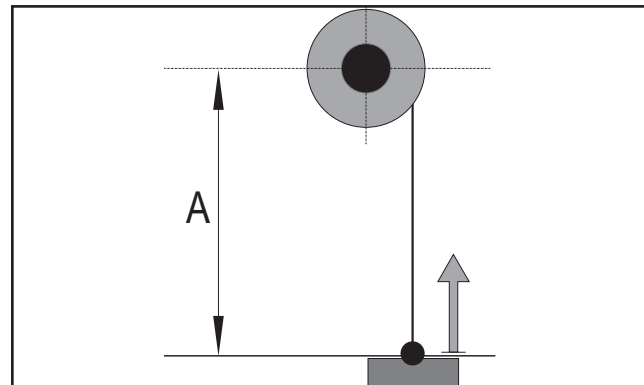

Figure 8-2 Lift Application

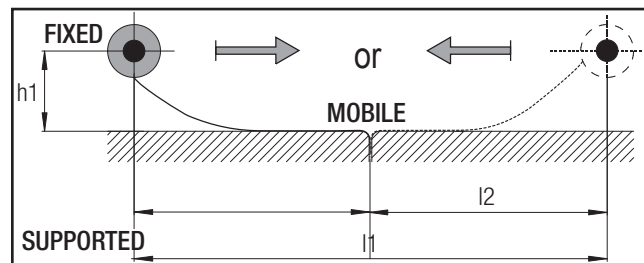

Figure 8-3 Drag Application

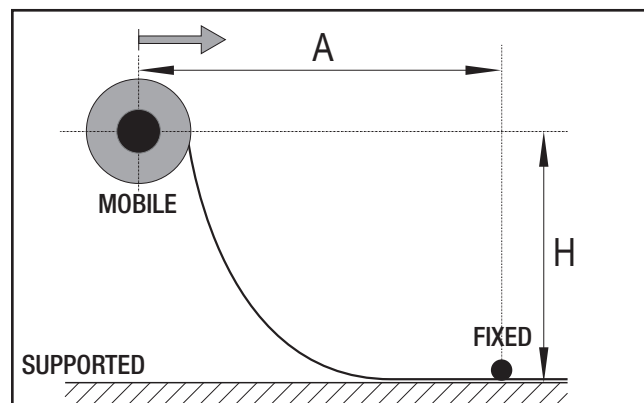

Figure 8-4 Retrieve Application

SECTION 3 - INSTALLATION

Pivot Base Mounting (Optional Accessory)

All 1200 Series Reels can be furnished with a pivot base to allow the reel to rotate and keep the extended cable perpendicular to the application. See **Figure 9-1**.

The PVB Pivot Base will rotate up to 345°. Travel can be limited to 90°, 180°, or 270° by installing an additional roll pin in the appropriate available hole.

A pivot base is required in carousel or loop track applications.

When a pivot base is used the reel must be mounted horizontally (“ceiling” or “floor” mounted).

The Roller Guide should be mounted so the cable travels perpendicular to the axis of rotation. This will guard against cable twisting and ensure effective swivel action from the pivot base.

Swing mount base available, consult factory.

Roller Guides

All 1200 Series units are equipped with a roller guide. The guide’s function is to center the cable on the spool and to help the reel wrap cable more evenly. See **Figure 9-2**.

1. The cable should not bear against either end of the spool during winding as this will inhibit level winding of the cable.
2. The guide should be secured at the best of twelve possible positions so that a minimum change of direction occurs at the guide; otherwise, cable life will be reduced.
3. The guide arm is shipped attached to the reel. The guide must be located and secured in the most appropriate position with the 5/16-18 hex head screw and lockwasher provided, prior to making any electrical connections.

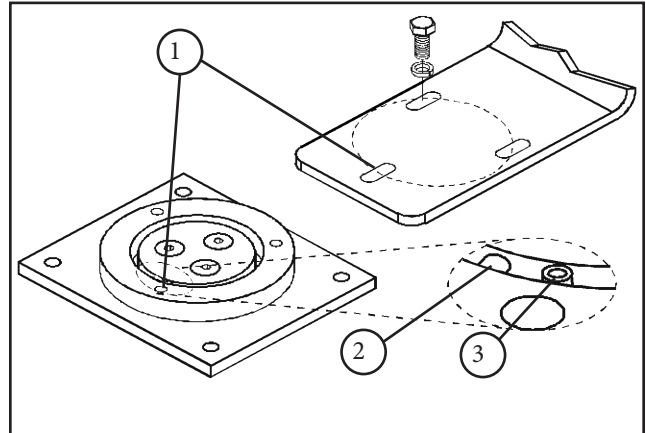

Figure 9-1

1. Key Mounting Hole
2. Fixed Pivot Stop
3. Traveling Pivot Stop

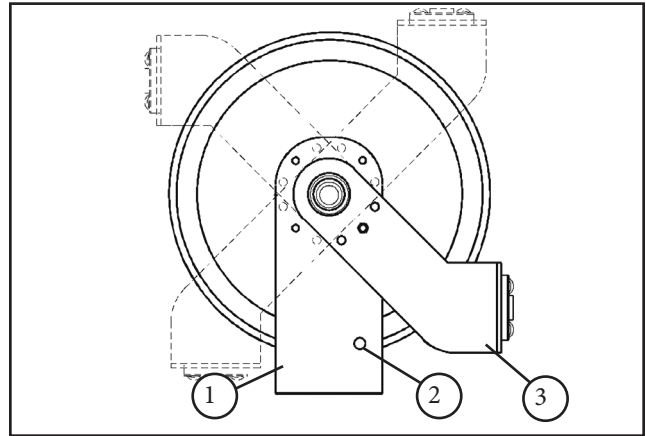

Figure 9-2

Roller Guide Locations

(4 of 12 possible positions shown)

Shaft Coupling XA-PR47-H

1. Base XA-41022BLK
2. Safety Chain Mounting Hole
3. Roller Guide XA-41012BLK

SECTION 3 - INSTALLATION

Ratchet

A ratchet option is available for 1200 Series DMX Gaffer Reels. See **Figure 10-1**.

A ratchet is used to lock the spool when used in hand operated situations. Consult factory for more information.

Cable Installation

Either of two methods for installing cable on the reel may be used. **The first method** is to simply lay the cable out straight along the path of travel and wrap onto the reel. **The second method** requires using a support for the cable being wrapped (see **Figure 11-1**). In either method, it is important that the cable not twist or loop.

1. Remove the four screws securing the outer flange. Remove outer flange, gasket and drum from the remaining assembly.
2. Strip back approximately 4" of cable jacketing.
3. Feed cable through the watertight and the drum, so that 1" of the jacket is through the watertight. Secure a cable-tie 1/4" from the end of the jacket and tighten watertight. Replace inner flange gasket if damaged. See **Figure 11-3**.
4. Strip and connect leads, using 24awg butt splices, to appropriate slip ring shaft lead. See Color Code Chart (**Table 10-1**).
5. Perform a continuity check to verify circuits.
6. Attach outer flange gasket and outer flange to drum (replace outer flange gasket if damaged) Attach with 10-32 x 3-1/2" screws. Longer screws will damage the reel.
7. Wrap new cable on drum spool.
8. Adjust spring tension by following the procedure.

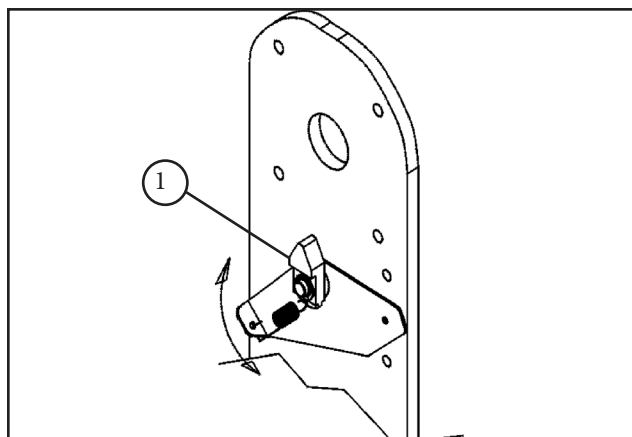

Figure 10-1 1. Ratchet

Color Code Chart		
Pin No.	Wire Color	Slip Ring Lead Color
1	All Drains	Brown
2	Black	Black
3	Red	Red
4	White	Yellow
5	Green	Green
		Orange

Table 10-1

SECTION 3 - INSTALLATION

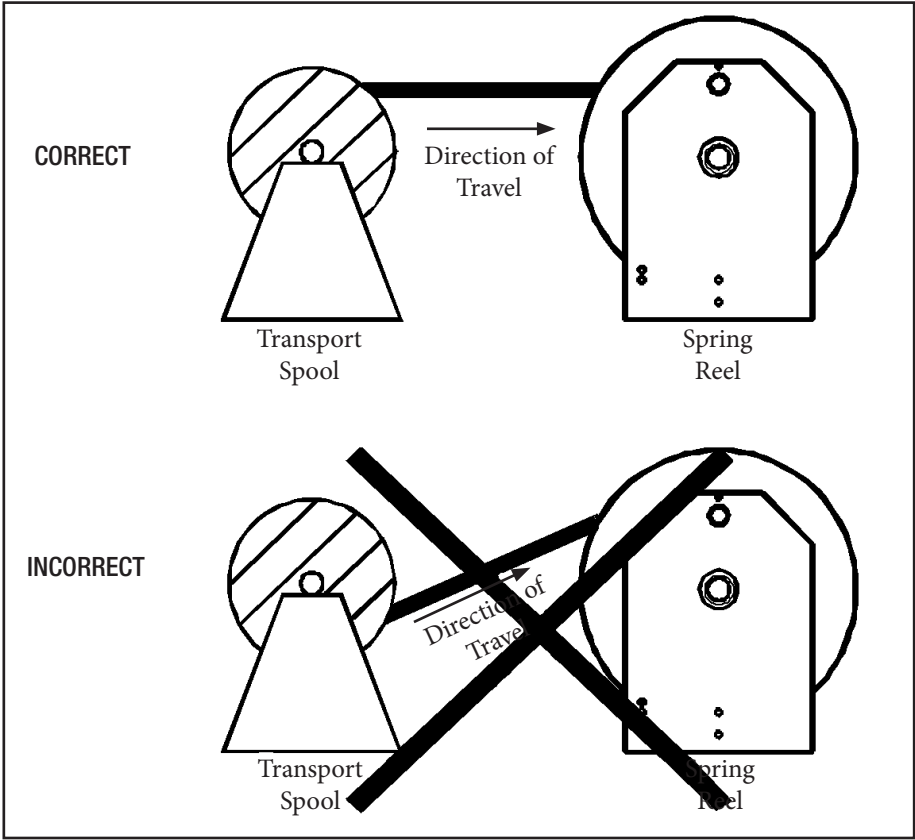

Figure 11-1

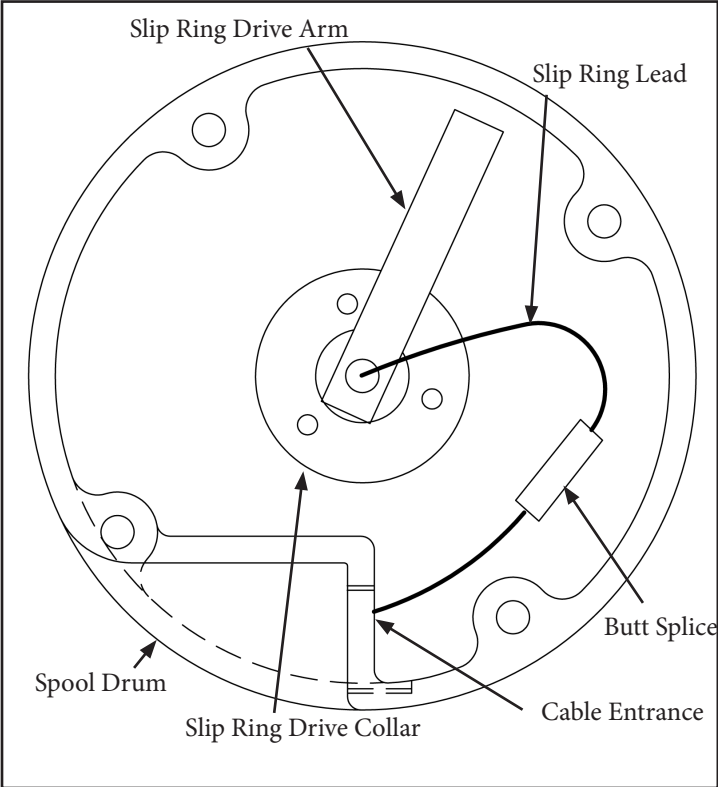

Figure 11-2 Proper Drum Orientation

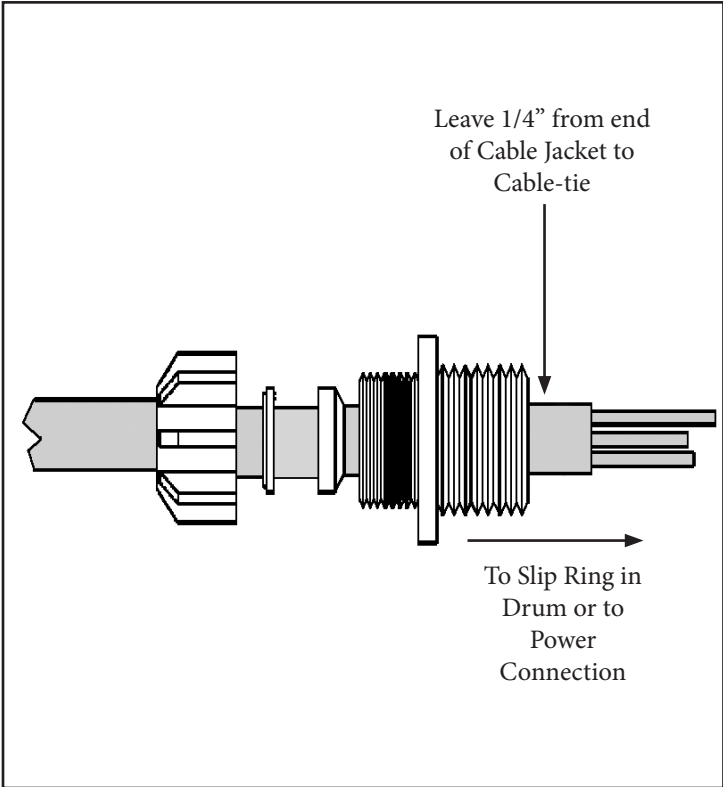

Figure 11-3 Watertight

SECTION 3 - INSTALLATION

Feeder Cord Connection

Power supply should have overcurrent protection to prevent overheating of the reel and cable.

1. Follow procedure in Slip Ring & Feeder Cord Replacement Section if feeder cord is not installed on reel.
2. Connect feeder cord to power supply, per NEC and local codes.

Spring Tension Adjustment

To assure that the cable will retract properly and operate under the correct tension, the reel should be tested. Install cable on drum but do not connect the free end of cable. Securely mount reel before testing. See **Figure 12-1**.

1. Pull the cable out approximately 20 - 30 feet and allow it to rewind. This procedure should be repeated five (5) to ten (10) times in order to set the spring. Walk the cable back to the reel during the spring tension adjusting process.

WARNING

- Do not allow cable to retract without restraining the retraction speed. Always maintain two full cable wraps on drum at maximum cable extension, size cable accordingly.

2. With all the cable wound on the reel, grasp the end of the cable and rotate the drum and cable together in a clockwise direction in order to pre-tension the spring. Generally, (1) full turn is adequate for most applications. Use no more than (2) full turns for pre-tension.
3. Feed the end of the cable through the cable guide and pull the cable out the required length. Note: the number of spool revolutions including the pre-tension turns should not exceed 30 turns. Consult factory or your representative if number of spool turns are not within parameter.
4. Repeat steps if necessary to add or decrease tension.

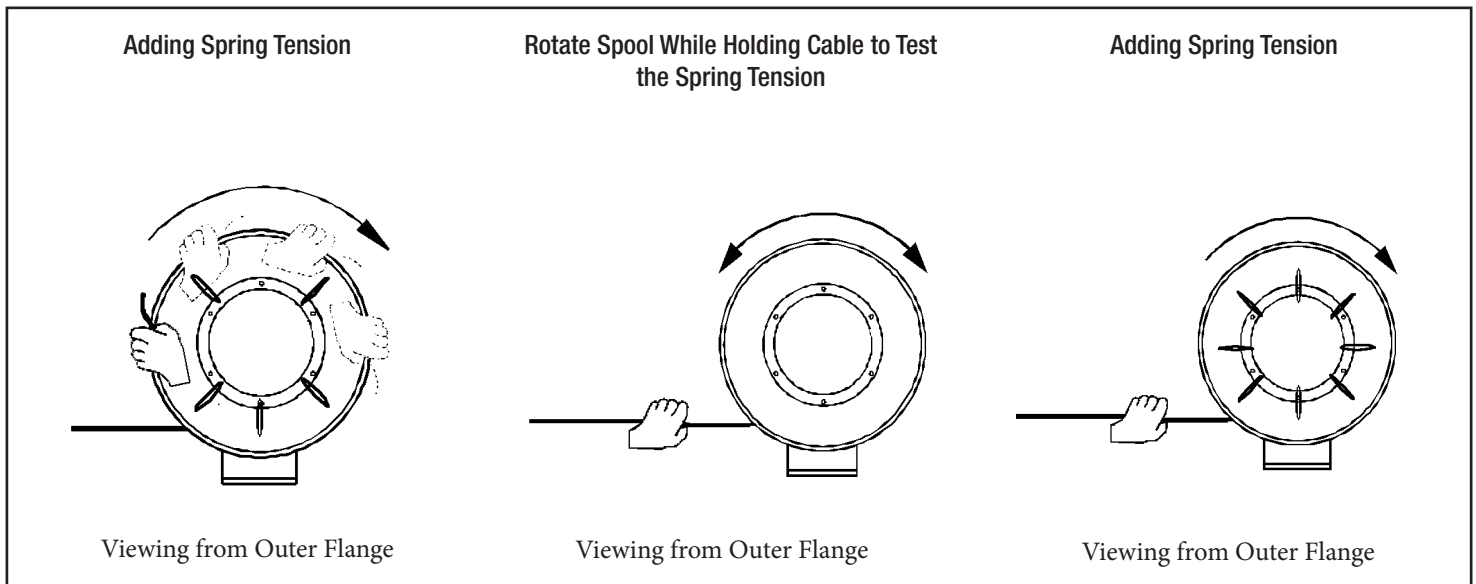

Figure 12-1

SECTION 4- OPERATION

- Do not exceed the voltage or ampere rating of the cable. Do not exceed the voltage or ampere rating of the reel. Overheating, fire, damage to equipment or personal injury could result.
- Do not allow cable to retract without restraining the retraction speed.
- Operate the reel within the cable size and length and spring tensioning limits for which it was intended.
- Two wraps of cable should remain on the reel at maximum extension to avoid excessive tension on the cable entrance watertight.
- The spring should not be wound to its last two turns at maximum payout to avoid overstressing the spring, thus reducing its life or damaging the reel.
- Keep the reel and cable clean to avoid excessive wear and damage.
- Arrange for maintenance service if damage is found on the cable or reel.
- Cable should be fully retracted when not in service to maximize spring life.

SECTION 5 - MAINTENANCE

WARNING

- Be sure all power is off for all maintenance.

Lubrication

- All springs and bearings are lubricated for life at the factory. Additional lubrication should not be required.
- Do not apply any lubricants or solvent cleaning agents to slip ring, brush or insulator surfaces.

Inspections

- Periodically check the reel for any loose or missing fasteners. Tighten or replace as necessary.

NOTE

- Do not over tighten, this will cause fasteners to snap.

- The slip ring assembly should be checked periodically as follows:
- Clean to remove dust and dirt from the slip ring housing area and slip ring assembly.

WARNING: Chemicals will damage rings, Scotch Brite Pads are recommended.

- Inspect cable for damage or wear which would make it unsafe to use.

Slip Ring & Feeder Cord Replacement

NOTE

- The slip ring assembly should be replaced, not rebuilt, if it becomes damaged.

1. Remove the (4) screws securing the outer flange. Remove outer flange and gasket from remaining assembly. Slide cable off the drum and lay next to the reel.
2. Pull drum off reel and lay on side next to slip ring. Disconnect wires.
3. Loosen feeder cord watertight located at the shaft end.
4. Loosen the set screw located in the black plastic hub on the shaft.
5. Remove the slip ring from the shaft while feeding in the feeder cord through the shaft. Cut wires as close to connections as possible.
6. Carefully and thoroughly clean the inside surfaces of both flanges and the drum. Inspect both gaskets for damage and replace as necessary.
7. Remove old feeder cord and Insert approximately 5” -10” of new feeder cord through the watertight and shaft.
8. Install inner gasket.
9. Connect the slip ring leads to the feeder cord with the provided connectors and install new slip ring. Feed feeder cord back through shaft and place slip ring on the shaft.
10. Tighten the set screw in the hub and tighten the watertight at the feeder cord end.
11. For remaining assembly, follow procedure in Cable Installation Section and then adjust spring tension.

Cable Replacement

Replacement cable should be the same size and length as existing cable. Any variations to cable specifications should be pre-approved by the factory.

1. Disconnect all electrical service to the reel before replacing the cable as per Lock-Out/Tag-Out procedures outlined in OSHA section 1910.147.
2. Disconnect the terminated service end of the cable and allow the cable to retract onto spool. Make sure the end of the cable is through the roller guide. Ensure all spring tension has been relieved by manually rotating the spool counter clockwise as viewed from outer flange.
3. Follow procedures outlined in Slip Ring & Feeder Cord Replacement and then remove cable.
4. Carefully and thoroughly clean the inside surfaces of both flanges and the drum. Inspect both gaskets for damage and replace as necessary.
5. Install new cable.
6. Follow procedure in Cable Installation Section and then adjust spring tension.

SECTION 5 - MAINTENANCE

Spring Motor Replacement



CAUTION

- Do not open the spring motor or personal injury may result.

The spring replacement process is determined by the spring configuration and cannot be performed in the field. The entire spring motor assembly must be replaced as a unit.

1. Disconnect all electrical power to the reel before beginning any maintenance or service.
2. Remove the slip ring and feeder cord from the reel by following the Slip Ring & Feeder Cord Replacement procedure.
3. Remove the watertight and coupling from the shaft.
4. Remove the spring motor by unscrewing the shaft from the mounting base.
5. Re-assemble spring reel in reverse order with the new spring motor. Note the following:
 - A. Shaft must be fully seated on base before installing coupling and watertight.
 - B. Adjust spring tension by following the spring tension procedure.

SECTION 6 - TROUBLESHOOTING

PROBLEM	POSSIBLE CAUSE	SOLUTION
Reel will not retract cable but has some tension.	<ol style="list-style-type: none"> 1) Improper pretension 2) Incorrect reel for application (lift vs. stretch). 3) Improper cable or cable length installed. 4) Cable guide adjustment 	<ol style="list-style-type: none"> 1) See Tension Adjustment section. 2) Quantify application vs. reel selection. 3) Install correct cable type and length. 4) Check guide alignment.
Reel does not have spring tension.	<ol style="list-style-type: none"> 1) Broken spring. *Quantify application to prevent reoccurrence. 	<ol style="list-style-type: none"> 1) Replace spring motor.
Ratchet will not engage.	<ol style="list-style-type: none"> 1) Broken ratchet pawl spring. 2) Lock out option arm disengaged. 	<ol style="list-style-type: none"> 1) Replace ratchet pawl spring. 2) Engage lock-out arm.
Ratchet will not disengage.	<ol style="list-style-type: none"> 1) Over-extension of reel. 	<ol style="list-style-type: none"> 1) Manually rotate reel spool to disengage ratchet. Do not over-extend (guide adjustment may prevent lock-up when over- extended). 2) Adjust ball stop.
Cable wraps improperly (uneven wrapping, wraps above or jumps flange).	<ol style="list-style-type: none"> 1) Reel mounting not level. 2) Cable retraction rate too high. 3) Cable guide out of adjustment. 4) Improper cable or cable length installed. 	<ol style="list-style-type: none"> 1) Mount reel on level surface. 2) Maintain steady retraction rate. 3) Properly adjust cable guide. 4) Install correct cable type and length.
Cable twisting or knotting.	<ol style="list-style-type: none"> 1) Improperly installed cable. 2) Cable rubbing on or bending around fixed object. 3) Excessive spring tension. 4) Inadequate anchoring of cable. 	<ol style="list-style-type: none"> 1) See Cable Install section in IOM. 2) Check roller guide for function and cable pay out path. 3) Quantify application vs. reel selection. Also check pretension. 4) Adjust anchoring method. ie. add strain relief.
Open or intermittent circuit.	<ol style="list-style-type: none"> 1) Inadequate connection. 2) Brush loses contact with slip ring. 3) Cable defective. 	<ol style="list-style-type: none"> 1) Check all termination points. 2) Replace ring assembly. 3) Perform continuity check on cable termination points.
	<ol style="list-style-type: none"> 1) Inadequate amp rating of reel selection. 2) Overloaded ring rating 	<ol style="list-style-type: none"> 1) Quantify application requirements vs. reel & cable rating. 2) Replace ring.

SECTION 7 - REPLACEMENT PARTS

Part Number	Description
XA-41012BLK	Roller Guide Arm Assembly
XA-PR47-H	Shaft Coupling
XA-41013	Outer Drum Gasket
XA-41005	Spool Drum
XA-41023	Inner Drum Gasket
XA-41003BLK	Outer Flange
XA-103456	Cable
XA-41028BLK G50	Spring Motor Assembly
XA-41017BLK	Base
XA-03666	Watertight
XA-103347	Slip Ring Capsule
*See exploded view on page 7 for more detailed information.	



CONDUCTIX-WAMPLER FIELD SERVICE

Need Field Service for our products? We Can Handle It!

Ask us for a quote on expert system installations, inspections, preventative maintenance, and repairs/retrofits.

As the world's largest single source manufacturer of mobile electrification products, Conductix-Wampfler has the unique ability to offer a degree of service not found anywhere else. Conductix-Wampfler's team of highly qualified service technicians and engineers have years of experience servicing our complete line of products.

We can provide:

- **Annual service contracts**
- **Installation**
- **Commissioning**
- **Installation supervision** to ensure your installers avoid common mistakes.
- **Troubleshooting** to get you up and running.
- **Pre-planned inspections** to complement your preventive maintenance program.

Call 1.800.521.4888 for further details.



www.conductix.us

USA / LATIN AMERICA

10102 F Street
Omaha, NE 68127

Customer Support
Phone +1-800-521-4888

Phone +1-402-339-9300
Fax +1-402-339-9627

info.us@conductix.com
latinamerica@conductix.com

com

CANADA

18450 J.A. Bombardier
Mirabel, QC J7J 0H5

Customer Support
Phone +1-800-667-2487

Phone +1-450-565-9900
Fax +1-450-851-8591

info.ca@conductix.com

MÉXICO

Calle Treviño 983-C
Zona Centro
Apodaca, NL México
66600

Customer Support
Phone (+52 81) 1090 9519
(+52 81) 1090 9025
(+52 81) 1090 9013

Fax (+52 81) 1090 9014

info.mx@conductix.com

BRAZIL

Rua Luiz Pionti, 110
Vila Progresso
Itu, São Paulo, Brasil

CEP: 13313-534
Customer Support
Phone (+55 11) 4813 7330

Fax (+55 11) 4813 7357
info.br@conductix.com

Contact USA for our Global Sales Offices

