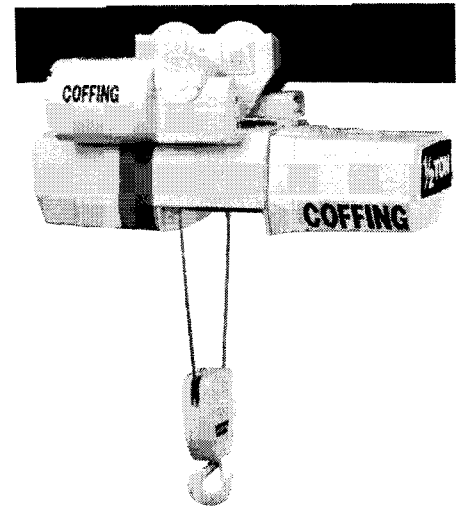


COFFING®

HOISTS

OPERATING & MAINTENANCE INSTRUCTIONS WITH PARTS LIST

Publication Part No. WR-1-680-3



WR-1 - Small Frame Electric Wire Rope Hoist

For Capacities:

1/2 - 1 Ton

IMPORTANT—CAUTION

To safeguard against the possibility of personal injury or property damage, follow the recommendations and instructions of this manual. This manual contains important information for the correct installation, operation, and maintenance of this equipment. All persons involved in the installation, operation, and maintenance of this equipment should be thoroughly familiar with the contents of this manual. Keep this manual for reference and further use.

⚠ WARNING

To prevent personal injury, do not use the equipment shown in this manual to lift, support, or otherwise transport people, or to suspend unattended loads over people.

TABLE OF CONTENTS

	Page		Page
Section I		Section IV Cont'd.	
Introduction.....	3	4-2. Frequent Inspection	9
1-1. General Information	3	4-3. Periodic Inspection.....	9
1-2. Safety Standards	3	4-4. Load Brake Function Check.....	11
1-3. Hoist Construction and Features.....	3	4-5. Wire Rope Inspection	12
1-4. Basic Hoist Data.....	3	4-6. Hook Throat Opening	12
1-5. Application Information	3	Section V	
1-6. Warranty.....	3	Maintenance and Report	13
Section II		5-1. General.....	13
Installation.....	4	5-2. Limit Switch Adjustment.....	13
2.1. Safety Notes.....	4	5-3. Motor Brake Adjustment	13
2.2. Trolley Installation	4	5-4. Wire Rope Replacement	13
2-3. Power Supply Connection	4	5-5. Lubrication.....	15
2-4. Vent Plug.....	4	Section VI	
2-5. Wire Rope Lubrication	4	Troubleshooting.....	17 & 18
2-6. Testing.....	4	Section VII	
Section III		Wiring.....	19
Operation.....	8	7-1. Voltage Conversion	19
3-1. General.....	8	7-2. Wiring Diagrams	19
3-2. Safety Notes.....	8	Section VIII	
3-3. Handling The Load.....	8	Illustrated Parts List.....	32
3-4. Overload Limiting Protection	8	8-1. General.....	32
Section IV		8-2. How To Use The Parts List	32
Inspection	9	8-3. How To Order Replacement Parts.....	32
4-1. General.....	9		

SECTION I

INTRODUCTION

1-1. General Information

This manual provides information for the safe operation and maintenance of Coffing WR-1 Series Hoists. All persons operating or maintaining these hoists should be familiar with the information contained herein. Adherence to the precautions, procedures, and maintenance practices described should ensure long reliable operation. Suggestions for improvements to this manual are solicited.

1-2. Safety Standards

All persons concerned with the installation, operation, inspection and maintenance of these hoists are urged to read American National Standard (ANSI) B30.16. That Standard contains valuable guidelines concerning practices designed to minimize hazards associated with the use of overhead hoisting equipment. ANSI B30.16 also contains detailed procedures for establishing hoist inspection and maintenance programs and can be of significant assistance in maintaining compliance with OSHA regulations.

1-3. Hoist Construction and Features

This hoist has a steel drum and center frame for strength in the load-bearing areas. Strong, lightweight aluminum alloy castings provide a compact, protective enclosure for the mechanical and electrical components.

Heat-treated alloy steel gearing operates in an oil bath to provide the most reliable lubrication and effective heat dissipation.

WR-1 Series Hoists incorporate the following features:

- a. Overload limiting clutch.
- b. Completely independent mechanical and electrical brakes.
- c. Adjustable limit switches.
- d. Tough, nylon, weatherproof pushbutton stations.
- e. Steel strain cable inside pushbutton cord.
- f. Transformer isolated, low-voltage pushbutton controls.
- g. Quick voltage conversion on dual-voltage units.

1-4. Basic Hoist Data

The basic hoist models covered by this manual are listed in Table 1-1.

TABLE 1-1. BASIC HOIST DATA

Model Number	Rated Load (Lbs)	Lift Speed At Rated Load (Ft. Per Min.)	Motor HP
WR-1010	1000	10	1/2
WR-1016	1000	16	1/2
WR-1021	1000	21	3/4
WR-1032	1000	32	1
WR-2010	2000	10	3/4
WR-2016	2000	16	1

1-5. Application Information

This hoist is intended for general industrial use in the lifting and transporting of freely suspended material loads within its rated load. Prior to installation and operation, the user should review his application for abnormal environmental or handling conditions and to observe the applicable recommendations as follows:

- a. **Adverse Environmental Conditions.** Do not use the hoist in areas containing flammable vapors, liquids, gases or any combustible dusts or fibers. Refer to Article 500 of *The National Electric Code*. Do not use this hoist in highly corrosive, abrasive or wet environments. Do not use this hoist in applications involving extended exposure to ambient temperatures below -10°F or above 130°F .
- b. **Lifting of Hazardous Loads.** This hoist is not recommended for use in lifting or transporting hazardous loads or materials which could cause wide-spread damage if dropped. The lifting of loads which could explode or create chemical or radioactive contamination if dropped requires fail-safe redundant supporting devices which are not incorporated into this hoist.
- c. **Lifting of Guided Loads.** This hoist is not recommended for use in the lifting of guided loads, including dumbwaiters and non-riding elevators. Such applications require additional protective devices which are not incorporated into this hoist. Refer to your state and local regulations governing the requirements for elevator and dumbwaiter installations.

1-6. Warranty

Every hoist is thoroughly inspected and tested prior to shipment from the factory. Should any problems develop, return the complete hoist prepaid to your nearest Coffing Authorized Warranty Repair Station. If inspection reveals that the problem is caused by defective workmanship or material, repairs will be made without charge and the hoist will be returned, transportation prepaid.

This warranty does not apply where: (1) deterioration is caused by normal wear, abuse, improper or inadequate power supply, eccentric or side loading, overloading, chemical or abrasive actions, improper maintenance or excessive heat; (2) problems resulted from repairs, modifications or alterations made by persons other than factory or Coffing Authorized Warranty Repair Station personnel; (3) the hoist has been abused or damaged as a result of an accident; (4) repair parts or accessories other than those supplied by Coffing are used on the hoist. Equipment and accessories not of the seller's manufacture are warranted only to the extent that they are warranted by the manufacturer. EXCEPT AS STATED HEREIN, COFFING MAKES NO OTHER WARRANTIES, EXPRESS OR IMPLIED, INCLUDING WARRANTIES OF MERCHANTABILITY AND FITNESS FOR A PARTICULAR PURPOSE.

SECTION II

INSTALLATION

2-1. Safety Notes

- a. Inspect the hoist for any evidence of shipping damage or loose parts.
- b. The supporting structure and load attaching devices should have a load rating at least equal to that of the hoist.
- c. This hoist is not suitable for use in uncovered outdoor locations or areas containing explosive dust, vapors or gases.
- d. The installation area must provide safe operating conditions for the operator, including sufficient room for the operator and other personnel to stand clear of the load at all times.

2-2. Trolley Installation

Coffing trolleys can be mounted on American Standard I Beams from 6 to 18 inches high. Adjustment for different beam dimensions is accomplished with the proper placement of spaced washers as described below.

- a. **“I”-Beam Adjustment.** Adjustment for “I” beam sizes and tolerances is accomplished by locating the spacer washers as shown in Figures 2-1, 2-2, and 2-3. Tables 2-1, 2-2, and 2-3 provide an approximate guide to washer placement. Be sure to use the proper Table, based on lift and trolley-type of the particular installation.

BEAM MANUFACTURING TOLERANCES ALLOW WIDE VARIATIONS FROM HANDBOOK FLANGE WIDTHS, AND SLIGHT CHANGES TO RECOMMENDED WASHER DISTRIBUTION MAY BE NECESSARY TO SUIT SPECIFIC INSTALLATIONS.

The particular beam on which your hoist is to be installed should be measured and trolley spacer washers adjusted as required to achieve a clearance of $\frac{3}{32}$ " to $\frac{1}{8}$ ".

Trolleys can be mounted on beam radii as small as 4 feet. Slightly increased spacing may be required when the trolley is mounted on curved beams to maintain freedom of movement.

The load pin nuts for the trolleys require a tightening torque of 100 ft. lbs. Refer to Figures 2-1, 2-2, and 2-3 for nut identification.

- b. **Periodic Inspection.** The trolley should be inspected periodically for evidence of excess wear or overload. Parts should be replaced as required.
- c. **Lubrication.** Trolley wheels are equipped with sealed, life-time lubricated, precision ball bearings which should not require lubrication for the normal service of the trolley.

2-3. Power Supply Connection

- a. Disconnect power before making connections.
- b. Voltage supplied to the hoist should be within plus or minus 10% of the voltage specified for the hoist. Hoists are tagged at the factory with a tag indicating the voltage for which the hoist is wired. Standard single-phase hoists are convertible from 115 to 230 volts. Standard single-speed, three-phase hoists are convertible from 460 volts to 230 volts. See the Wiring section (paragraph 7-1) for voltage conversion instructions.
- c. National Electrical Code (ANSI C1) and local electrical codes should be consulted and proper disconnects, branch circuit protectors, and wiring provided.

- d. Power cables furnished with the hoist have a green colored ground wire which must be securely connected to the electrical system ground.
- e. When installing a three-phase hoist, make only temporary connections at the power line. Push the “UP” button and observe the direction of the hook. If it raises, the phasing is correct and permanent connections may be made at the power line. If the load block lowers when the “UP” button is pushed, release the button immediately since the limit switches will not operate to protect the hoist from over-travel. Reverse the red and black wires at the power line connection to correct the hook direction.

CAUTION

Do not change connections in the hoist or the pushbutton assembly.

2-4. Vent Plug

This hoist has an oil-bath transmission. For shipping purposes, a non-vented fill plug (39, Figure 8-4) was installed at the factory. A vented plug is located in an envelope tied to one of the hoist end covers and must be installed in place of the non-vented shipping plug before operating the hoist.

2-5. Wire Rope Lubrication

It is important that the wire rope is lubricated before the hoist is put into service. Wire rope lubricant is packed with each hoist. For lubrication instructions, see paragraph 5-5a. Additional lubricant is available from your Duff-Norton distributor. Specify Part No. 14J49.

2-6. Testing

- a. Before placing the hoist into operation, check for proper limit switch operation. Push the “UP” button and verify that the hook block stops at least 2 inches from the bottom of the hoist. Run the hoist down to its lower limit. At least 2 wraps of wire rope should remain on the drum. If either switch is not correct, adjust according to the procedure outlined in paragraph 5-2.

NOTE

The upper and lower limit switches are factory set to provide the maximum allowable hook travel. **This travel adjustment should not be increased.** However, the switches may be adjusted to stop the hook sooner at either end of its travel.

- b. Wire rope life can be extended by a short breaking-in period before the hoist is put into service. During this breaking-in period, a small amount of twist may show up in the rope. This twist should be removed as described below. This break-in can be done at the time of hoist testing:

1. Attach a light load to the hook and run the hoist through its full lift stroke for a few lifting and lowering cycles. Check for hook drift. The hook should not drift more than one inch.

2. If brake operation is normal with a light load, repeat the above procedure with approximately one-half rated load, again running the hoist through its full lift stroke for a few cycles. Check again for hook drift.

3. If brake operation is normal with one-half rated load, attach rated load to the hook and continue the break-in procedure. The hoist shall operate smoothly and the brake should prevent hook drift in excess of one inch at rated load. See paragraph 5-3 if motor brake adjustment is required.

4. Set the load on the floor. Disconnect the dead end of the wire rope as described in paragraph 5-4.a.8. Allow the dead end to rotate, in order to remove all twist from the rope. Reconnect the dead end and be sure to replace and tighten the anchor screws.

**WR-1 HOISTS ON COFFING TROLLEYS
FOUR-WHEEL TROLLEY ON 3" SUSPENSION YOKE
(Applies to hoists with a single trolley.)**

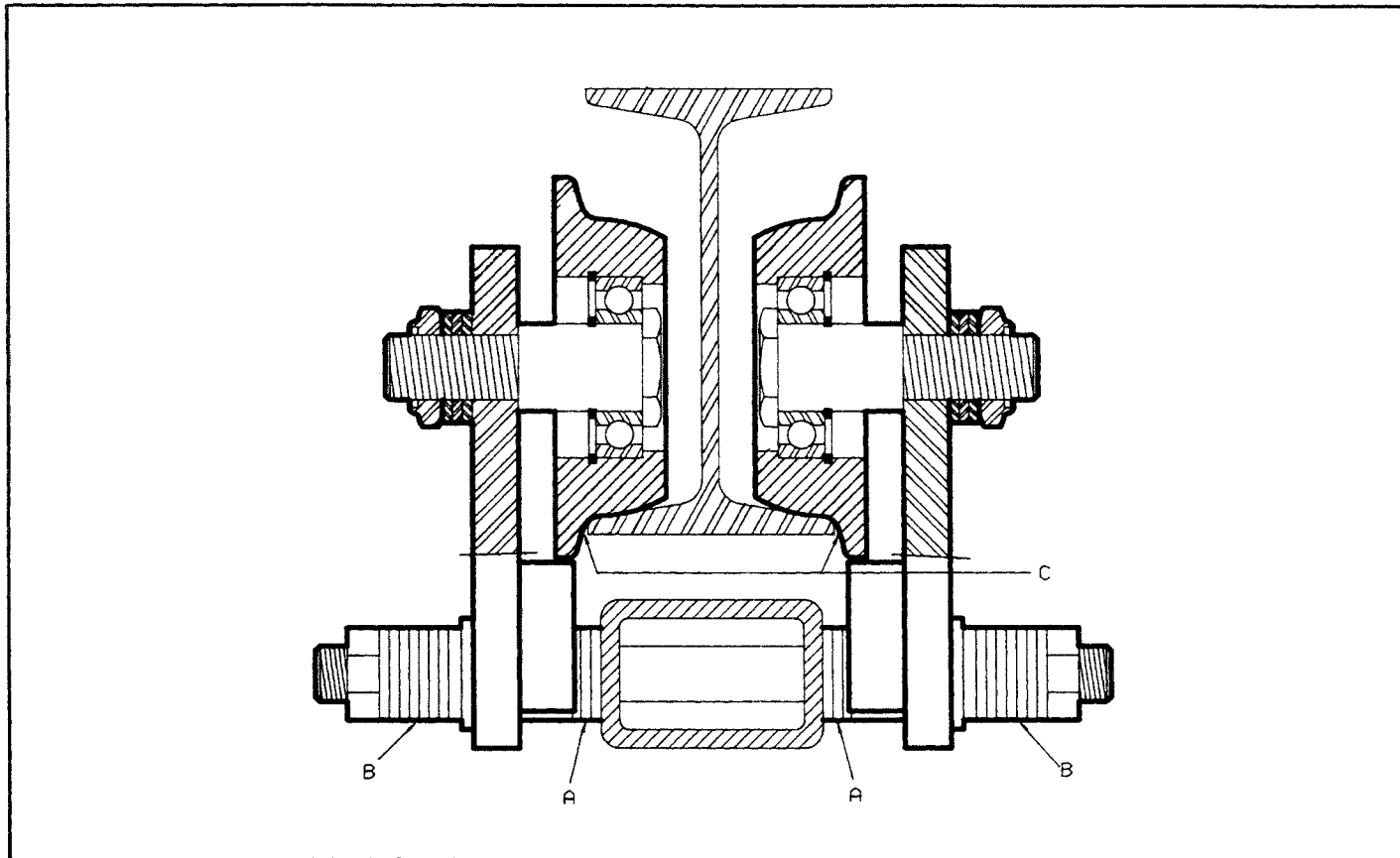


FIGURE 2-1

TABLE 2-1. TROLLEY I-BEAM ADJUSTMENT DATA

I-Beam* Size & Weight	Flange Width	Point A Washer Between Susp. Yoke & Sleeve		Point B Washers Between Sideplate & Nut		Actual Spacing Susp. Lug to Sleeve	Point C Clearance Wheel to Beam
		.135 Thick	.075 Thick	.135 Thick	.075 Thick		
6" - 12.5 #	3.330	0	5	8	8	.375	.099
6" - 17.25 #	3.565	2	3	6	10	.495	.102
8" - 18.4 #	4.000	3	4	5	9	.705	.094
8" - 23.0 #	4.171	2	7	6	6	.795	.099
10" - 25.4 #	4.660	1	12	7	1	1.035	.094
10" - 35.0 #	4.944	6	5	2	8	1.185	.102
12" - 31.8 #	5.000	4	9	4	4	1.215	.104
12" - 35.0 #	5.078	7	4	1	9	1.245	.095
15" - 42.9 #	5.500	7	7	1	6	1.470	.109
15" - 50.0 #	5.640	8	6	0	7	1.530	.099
18" - 54.7 #	6.000	6	12	2	1	1.710	.099

*American Standard I-Beam

NOTE: All dimensions are in inches unless otherwise specified.

**FOUR-WHEEL TROLLEY ON 3⁵/₈" SUSPENSION ADAPTER
(Applies to hoists with dual trolleys.)**

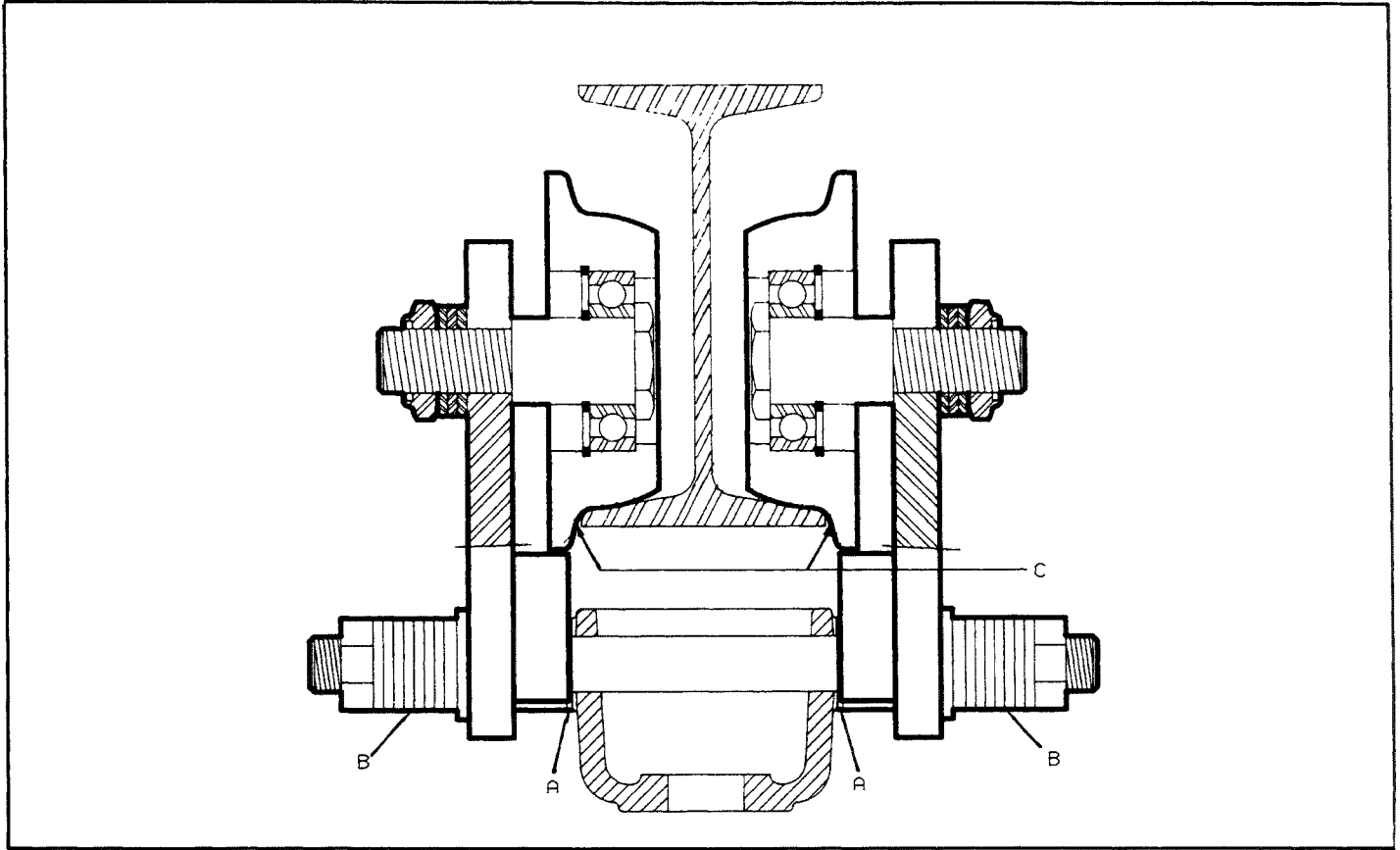


FIGURE 2-2

TABLE 2-2. TROLLEY I-BEAM ADJUSTMENT DATA

I-Beam* Size & Weight	Flange Width	Point A Washer Between Susp. Adaptor & Sleeve		Point B Washers Between Sideplate & Nut		Actual Spacing Susp. Adaptor to Sleeve	Point C Clearance Wheel to Beam
		.135 Thick	.075 Thick	.135 Thick	.075 Thick		
6" - 12.5#	3.330	0	1	7	8	.075	.111
6" - 17.25#	3.565	1	1	6	8	.210	.129
8" - 18.4#	4.000	3	0	4	9	.405	.106
8" - 23.0#	4.171	3	1	4	8	.480	.096
10" - 25.4#	4.660	1	8	6	1	.735	.106
10" - 35.0#	4.944	2	8	5	1	.870	.099
12" - 31.8#	5.000	4	5	3	4	.915	.116
12" - 35.0#	5.078	3	7	4	2	.930	.092
15" - 42.9#	5.500	7	3	0	6	1.170	.121
15" - 50.0#	5.640	4	9	3	0	1.215	.096
18" - 54.7#	6.000	6	8	1	1	1.410	.111

*American Standard I-Beam

NOTE: All dimensions are in inches unless otherwise specified.

**TWO-WHEEL TROLLEY ON 3⁵/₈" SUSPENSION ADAPTER
(Applies to hoists with dual trolleys.)**

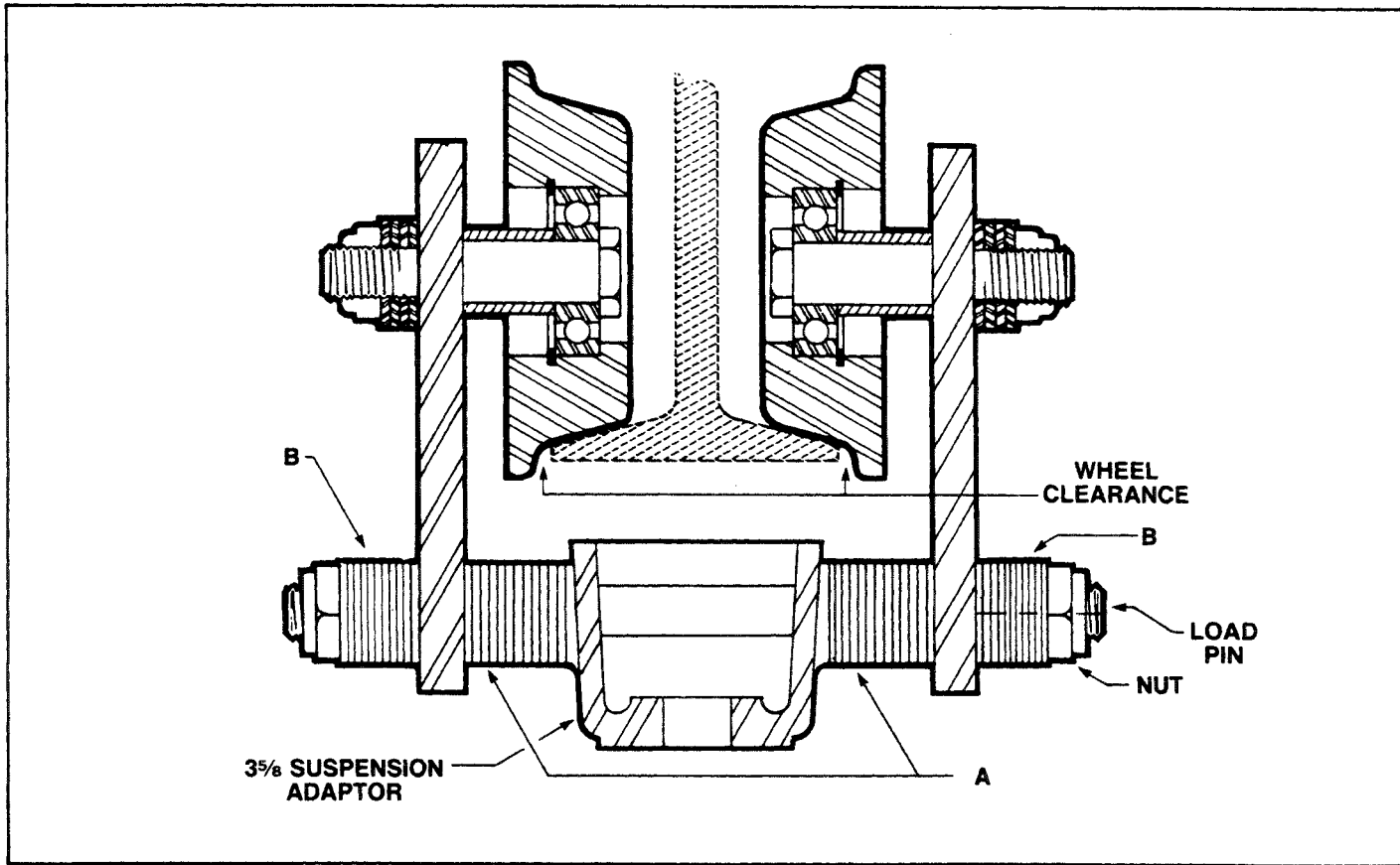


FIGURE 2-3

TABLE 2-3. TROLLEY I-BEAM ADJUSTMENT DATA

I-Beam* Size & Weight	Flange Width	Point A Washer Between Sus. Adaptor & Sideplate		Point B Washers Between Sideplate & Nut		Actual Spacing Susp. Lug to Sideplate	Point C Clearance Wheel to Beam
		.135 Thick	.075 Thick	.135 Thick	.075 Thick		
6" - 12.5#	3.330	3	5	8	5	.780	.097
6" - 17.25#	3.565	5	3	6	7	.900	.100
8" - 18.4#	4.000	5	6	6	4	1.125	.107
8" - 23.0#	4.171	5	7	6	3	1.200	.097
10" - 25.4#	4.660	8	5	3	5	1.455	.107
10" - 35.0#	4.944	9	5	2	5	1.590	.100
12" - 31.8#	5.000	7	9	4	1	1.620	.102
12" - 35.0#	5.078	10	4	1	6	1.650	.093
15" - 42.9#	5.500	11	5	0	5	1.860	.092
15" - 50.0#	5.640	11	6	0	4	1.935	.097
18" - 54.7#	6.000	11	9	0	1	2.160	.142

* American Standard I-Beam

NOTE: All dimensions are in inches unless otherwise specified.

SECTION III OPERATION

3-1. General

This section presents information concerning the proper operation on the Coffing Electric Wire Rope Hoist. It is not intended to serve as a handbook on rigging. Rigging, the process of moving heavy loads using mechanical devices, requires special knowledge and equipment. For information on the safe use of slings and similar rigging gear, users are urged to consult a textbook on rigging.

3-2. Safety Notes

- a. Inspect the hoist for any sign of loose, broken, or malfunctioning parts (see Section IV). Any malfunctioning hoist should be tagged as “out of order” and removed from service until the defect is corrected.
- b. Before starting the hoist, the operator should be certain that all personnel are clear.
- c. Do not lift more than the rated load of the hoist.
- d. Do not lift people or loads over people.
- e. Avoid jogging controls or quick reversals of suspended loads.
- f. Do not leave a suspended load unattended.
- g. The operator should have a clear view of the load anytime it is moving and should be sure that the load does not contact any obstructions.
- h. Read ANSI B30.16 Safety Standard for Overhead Hoists.

3-3. Handling The Load

- a. Align hoist directly over load. Avoid side pull, since this can cause the wire rope to jump grooves, or overwrap itself. This condition will quickly damage the wire rope.

- b. The wire rope should not be wrapped around the load. Use proper slings.
- c. Be sure the wire rope is properly seated in the drum groove and in the bottom block sheave.
- d. Bring the hook into engagement with the load and make sure it is well seated before proceeding to lift the load. Be sure that the load is equalized on all supporting ropes.
- e. Lift the load just clear of its supports and stop the hoist to check for proper brake operation.
- f. Avoid letting the hook or load swing excessively while moving a trolley suspended hoist.

3-4. Overload Limiting Protection

This hoist is equipped with a factory-calibrated overload limiting clutch, which permits lifting loads within rated capacity and prevents lifting excessive loads which could damage the hoist. If the load exceeds the lifting capability of the overload clutch, the hoist will not lift the load, but the motor will run as long as the “UP” button is pressed. Repeated attempts to lift an excessive load will overheat the overload clutch and cause permanent damage to the clutch.

CAUTION

The overload limiting clutch is an emergency protection device. It should not routinely be used to measure the maximum load to be lifted.

SECTION IV

INSPECTION

4-1. General

A scheduled inspection routine should be established for this hoist based upon severity of use and environmental conditions. Some inspections should be made frequently (daily to monthly) and others periodically (monthly to yearly). It is suggested that an Inspection and Maintenance Check List and an Inspector's Report similar to those shown in Figures 4-1 and 4-2 be used and filed for reference. All inspections should be made by a designated inspector. Special inspections should be made after any significant repairs or any situation causing suspicion that the hoist may have been damaged. Any hoist which has been removed from service for an extended time should receive an inspection as described under Periodic Inspections. ANSI B30.16, Safety Standard for Overhead Hoists, provides guidelines for hoist operation and inspection.

CAUTION

Any unsafe condition disclosed by any inspection must be corrected before operation of the hoist is resumed.

4-2. Frequent Inspection

- a. Check pushbutton station, brake, and limit switches for proper operation.
- b. Check hooks for deformation, chemical damage, or cracks. Bent hooks or hooks damaged from chemicals, deformation, cracks, or having excessive throat opening (see paragraph 4-6) should be replaced. Visible deformation of any hook may be evidence of hoist abuse and overloading and indicates that a thorough inspection of the complete hoist should be made.
- c. Check that bottom hook swivels freely.
- d. Check for missing, bent or otherwise damaged hook latches.
- e. Check pushbutton and power cord for cuts or other damage.
- f. Check wire rope for wear, twist, distortion or kinks.

4-3. Periodic Inspection

The exact period for the following inspections will depend on the anticipated severity of hoist use. Determination of this period should be based on the user's experience. It is recommended that the user begin with a monthly inspection and extend the periods to quarterly, semi-annually, or annually, based on his monthly inspection experience.

- a. Clean hoist of any dirt or foreign material. Inspect bottom block for accumulation of debris.
- b. Perform all frequent inspections listed above.
- c. Check for loose bolts, screws and nuts.
- d. Check housings, load block, and other parts for wear, corrosion, cracks or distortion. Check for abnormal openings between housing sections.
- e. Check motor brake for worn discs, oil contamination or excessive clearance (see paragraph 5-3).
- f. Check mechanical load brake function (see paragraph 4-4).
- g. Inspect the entire length of wire rope for deficiencies. See WIRE ROPE INSPECTION, paragraph 4-5.
- h. Inspect hooks and suspension parts for cracks, distortion or extreme wear.
- i. Inspect hooks for cracks using magnetic particle, dye penetrant or other crack detecting methods.
- j. Check limit switch set points and reset if necessary (see paragraph 5-2).
- k. Inspect all wiring for defective insulation, and check to be sure all electrical connections are tight. Check motor reversing contactor or relay for burned contacts.
- l. Inspect for oil leaks. Check oil level.
- m. Inspect for missing or illegible capacity or warning labels.
- n. Inspect the supporting structure for continued ability to support the hoist rated load.

**INSPECTION & MAINTENANCE CHECK LIST
ELECTRIC POWERED OVERHEAD WIRE ROPE HOIST**

TYPE OF HOIST _____ CAPACITY (TONS) _____
 LOCATION _____ ORIGINAL INSTALLATION DATE _____
 MANUFACTURER _____ MANUFACTURER'S SERIAL NO. _____

ITEM	FREQUENCY OF INSPECTION			POSSIBLE DEFICIENCIES	OK	ACTION REQUIRED
	FREQUENT		PERIODIC 1-12 MO.			
	DAILY	MONTHLY				
Operating Controls	•	•	•	Any deficiency causing improper operation		
Limit Switches	•	•	•	Any deficiency causing improper operation Pitting or deterioration		
Disc (Motor) Brake	•	•	•	Slippage or excessive wear Glazing, contamination or excessive wear		
Load Brake (Mechanical)			•	Failure to support load with disc brake open (see Figure 4-8)		
Hooks	•	•	•	Excessive throat opening, bent or twisted more than 10 degrees, damaged hook latch, wear, chemical damage, worn hook bearing • Cracks (use dye penetrant, magnetic particle or other suitable detection method)		
Suspension Lug			•	Cracks, excessive wear or other damage which may impair the strength of the lug • Cracks (use dye penetrant, magnetic particle or other suitable detection method)		
Wire Rope	•	•	•	Inadequate lubrication, wear, twist, distortion, improper dead-ending, deposits of foreign substance • Deterioration or wear resulting in appreciable loss of original strength		
Suspension Lug Connections			•	Cracks, bending, stripped threads, damaged suspension studs		
Pins, Bearings, Bushings, Shafts Couplings, Gears			•	Excessive wear, corrosion, cracks, distortion		
Nuts, Bolts, Rivets			•	Looseness, stripped and damaged threads, corrosion		
Sheave, Drum			•	Distortion, cracks, and excessive wear Build up of foreign substances		
Housings, Load Block			•	Cracks, distortion, excessive wear, Internal build up of foreign substances.		
Wiring and Terminals			•	Fraying, defective insulation		
Contact Block, Magnetic Hoist Control Switch, Other Electrical Apparatus			•	Loose connections, burned or pitted contacts		
Supporting Structure and Trolley (if used)			•	Damage or wear which restricts ability to support imposed loads		
Nameplates, Decals, Warning Labels			•	Missing, damaged or illegible		
Transmission Lubricant			•	Low Level, Requires Changing		

NOTE: Refer to Maintenance and Inspection Sections of the Hoist Maintenance Manual for further details.

FREQUENCY OF INSPECTION:

Frequent— Indicates items requiring inspection daily to monthly. Daily inspections may be performed by the operator if properly designated.

Periodic— Indicates items requiring inspection monthly to yearly. Inspections to be performed by or under the direction of a properly designated person. The exact period of inspection will depend on frequency and type of usage. Determination of this period will be based on the user's experience. It is recommended that the user begin with a monthly inspection and extend the periods to quarterly, semi-annually or annually based on his monthly experience.

FIGURE 4-1. RECOMMENDED INSPECTION AND MAINTENANCE CHECK LIST

INSPECTOR'S REPORT	
ITEM	REMARKS (LIST DEFICIENCIES AND RECOMMENDED ACTION)
INSPECTOR'S SIGNATURE	DATE INSPECTED APPROVED BY DATE

FIGURE 4-2. RECOMMENDED INSPECTOR'S REPORT

4-4. Load Brake Function Check

To check the functioning of the mechanical load brake, proceed as follows:

- a. Attach a light load to the hoist and lift it several inches.
- b. **DISCONNECT HOIST FROM POWER SUPPLY** and remove short end brake cover (see Figure 8-1, Index No. 1).
- c. Referring to Figure 4-3 and Figure 8-9, place screwdrivers No. 1 and No. 2 behind the plate and armature assembly and prepare to pry against the transmission cover.

NOTE

Do not allow either screwdriver to contact brake disc (see Figure 8-9, Index No. 7).

- d. Carefully pry open motor brake (close solenoid gap) and observe action of load. If the load accelerates, the mechanical load brake is malfunctioning and must be repaired.

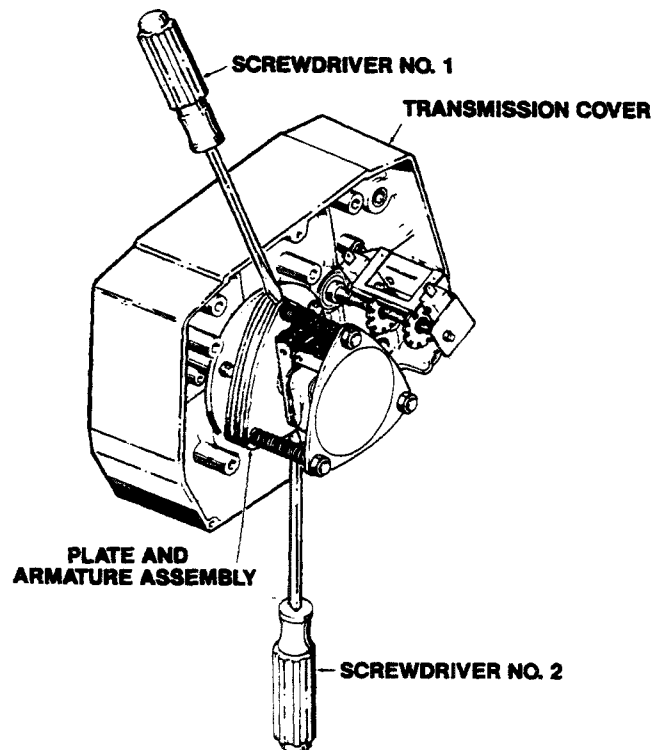


FIGURE 4-3. LOAD BRAKE FUNCTION CHECK LIST

4-5. Wire Rope Inspection

a. Make a thorough inspection of the wire rope at least once each month and keep a written, dated and signed report of rope condition on file. Any deterioration, resulting in appreciable loss of original strength, such as described below, shall be carefully noted and determination made as to whether further use of the rope would constitute a safety hazard. See Figure 4-4 for identification of wire rope components.

1) Reduction of rope diameter below nominal due to loss of core support, internal or external corrosion or wear of outside wires.

2) A number of broken outside wires and the degree or distribution or concentration of such broken wires.

3) Worn outside wires.

4) Sections of rope which are normally hidden during inspection or maintenance procedures, such as parts passing over sheaves, should be given close inspection as these are points most subject to deterioration.

5) Corroded or broken wires at end connections.

6) Corroded, cracked, bent, worn or improperly applied end connections.

7) Kinking, crushing, cutting or unstranding.

b. No precise rules can be given for determination of exact time for replacement of wire rope, since many variable factors are

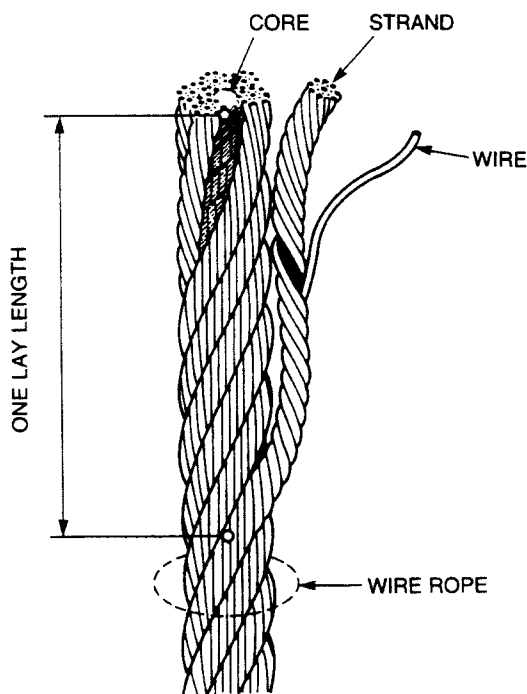


FIGURE 4-4. BASIC COMPONENTS OF WIRE ROPE

involved. Safety in this respect depends largely upon the use of good judgment in evaluating remaining strength in the used rope after allowance for deterioration disclosed by inspection. Safety of rope operation depends upon this remaining strength. Conditions such as the following should be sufficient reason for questioning rope safety and consideration of replacement.

1) Twelve randomly distributed broken wires in one rope lay length or four broken wires in one strand in one rope lay length. One lay is the length, parallel to the longitudinal axis, in which a strand makes one complete turn about the axis of the rope. See Figure 4-4.

2) Two wires broken adjacent at the end fittings.

3) Wear of one-third of the original diameter of outside individual wires.

4) Kinking, crushing, birdcaging or any other damage resulting in distortion of the rope structure.

5) Evidence of any heat damage from any cause.

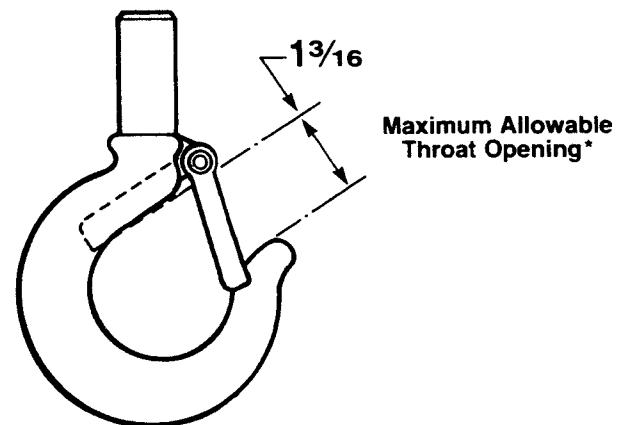
6) Reductions from nominal $\frac{1}{4}$ inch diameter to $\frac{15}{64}$ inch.

CAUTION

Use only wire rope assemblies supplied by our company since replacement rope assemblies must be of the same size, grade and construction rope and have the same swaged end fittings as the original rope assembly.

4-6. Hook Throat Opening

Check throat opening as indicated in Figure 4-5. Replace hook if measurement exceeds the allowable.



*Dimension of throat opening with internal latch.
NOTE: Add $\frac{1}{16}$ " if measured without hook latch.

FIGURE 4-5. HOOK THROAT OPENING

SECTION V

MAINTENANCE AND REPAIR

5-1. General

This section provides instructions for the most common routine maintenance and adjustments. Major repairs are not within the scope of this manual and should be referred to qualified service facilities.

SAFETY NOTE

Always remove load and disconnect hoist from power supply before removing end covers or making repairs.

5-2. Limit Switch Adjustment

Limit switches are provided to protect the hoist against damage resulting from overtravel. For easy identification the upper (No. 2, Figure 5-1) and lower (No. 3, Figure 5-1) limit switch adjusting nuts are colored brass and zinc respectively. Each limit switch nut has ten slots for adjustment, and the increment of adjustment is such that one slot is equivalent to approximately $\frac{3}{4}$ " of hook travel. Care should be exercised when adjusting either limit of travel.

a. Adjusting Upper Limit (Brass Nut).

- 1) Carefully raise the load block to a point where its top is 2" or more from the hoist housing.
- 2) DISCONNECT POWER from the hoist and remove the short end cover.
- 3) With a screwdriver, pry the spring guide plate (No. 1, Figure 5-1) out of the slots in the colored limit switch nuts (Nos. 2 and 3).

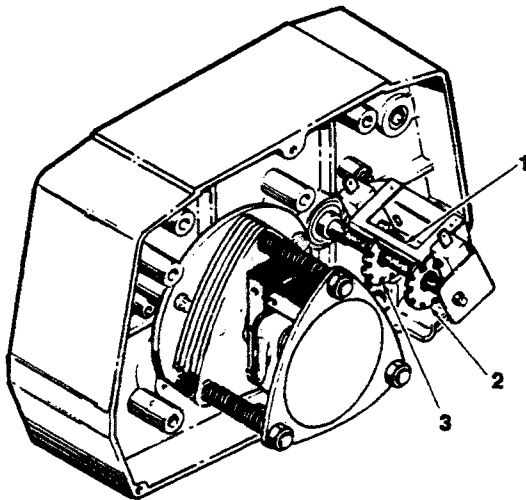


FIGURE 5-1. LIMIT SWITCH ADJUSTMENT

- 4) Turn the slotted brass nut (No. 2) toward its limit switch until the switch clicks.
- 5) Release the spring guide plate and be sure it snaps back into the slots in both nuts. Do not disturb the other slotted nut if it has been previously set.
- 6) Replace the short end cover and reconnect power to the hoist.
- 7) Carefully raise the load block to its upper limit and observe to see if it stops automatically at the desired point. Do not allow the load block to run into the hoist drum. The stopping point should be at least 2" below the hoist drum.

b. Adjusting Lower Limit (Zinc Nut)

- 1) Carefully lower the load block to a point where at least 2 wraps of wire rope remain on the drum.
- 2) DISCONNECT POWER from the hoist and remove the short end cover.
- 3) Adjust the zinc limit switch nut in the same manner described above for the brass nut.
- 4) Replace the short end cover and reconnect power to the hoist.
- 5) Carefully lower the load block to its lower limit and observe if it stops automatically at the desired level. At least 2 wraps of wire rope should remain on the drum.

NOTE

If upper and lower limits are not operating satisfactorily, repeat adjustment.

5-3. Motor Brake Adjustment

When properly adjusted, the multiple disc motor brake should release promptly, operate without noticeable chatter, and stop the load with no more than one inch of drift. If the hoist hesitates to lift the load promptly when the pushbutton is depressed, the brake should be adjusted per the following procedure.

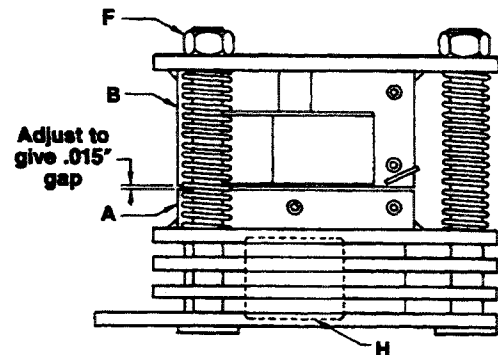


FIGURE 5-2. MOTOR BRAKE ADJUSTMENT

- a. Remove any load and DISCONNECT POWER from hoist.
- b. Remove the short end cover.
- c. Referring to Figure 5-2, check the gap between armature (A) and frame (B). The correct gap is .015".
- d. Adjust the gap by turning the three lock nuts (F) and check with a feeler gauge to be sure the gap is the same on both ends of the solenoid.

CAUTION

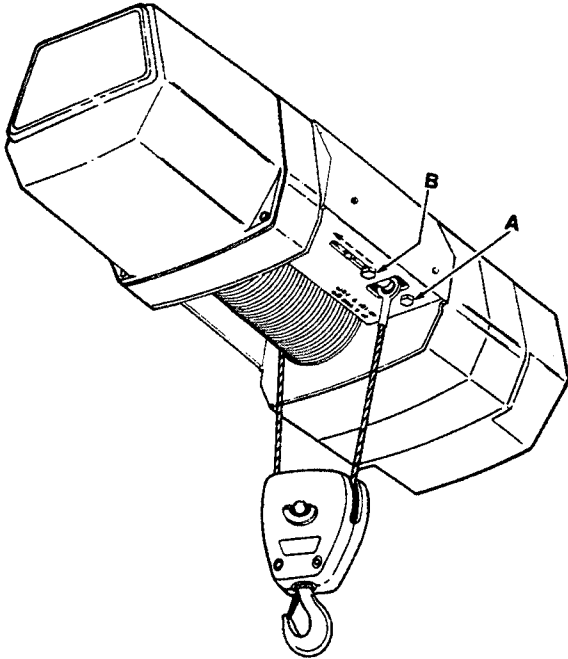
Be sure the bottom of the armature does not touch the splined adapter (H). As wear occurs, the original clearance will be reduced. When this clearance is gone, THE BRAKE DISCS MUST BE REPLACED.

- e. Replace short end cover and reconnect power. If the brake still chatters or is hesitant to release, refer to Section VI, Troubleshooting.

5-4. WIRE ROPE REPLACEMENT

For hoists reeved Two Part Single, see paragraph 5-4a. For hoists reeved Two Part Double see paragraph 5-4b.

- a. **HOISTS REEVED TWO PART SINGLE:** Refer to Figure 5-3 for parts identification and proper rope reeving.



**FIGURE 5-3. TWO PART SINGLE REEVING:
STANDARD HEADROOM MODELS**

- 1) Push "DOWN" button and run old rope out until stopped by lower limit switch.
- 2) Disassemble the load block by removing the screws (9, Figure 8-9A) and one spring pin (3, Figure 8-9A). Clean and inspect the block, hook, sheave, bearings, and pin for wear, damage, etc. Replace parts as necessary. Do not reassemble the load block at this point.
- 3) **DISCONNECT POWER** from the hoist and remove the short end cover.
- 4) With a screwdriver, push the spring guide plate (1, Figure 5-1) out of the slots in the limit switch nuts. Turn the zinc slotted nut (3) back to about the center of the threaded screw. **DO NOT DISCONNECT THE WIRES FROM THE LIMIT SWITCHES.**
- 5) With the end cover off, connect hoist to power supply. Be sure the green wire is grounded.
- 6) Carefully jog the "DOWN" button until all the old rope is run off and the drum socket opening is accessible.
- 7) **DISCONNECT POWER** from the hoist.
- 8) Disconnect old rope dead end eye by removing one dead end anchor screw (A, Figure 5-3) and loosening the other screw (B) approximately three turns. Lift the dead end eye up and slide the anchor pin back by grasping the head of screw (B).
- 9) Slide the sleeve fitting out of the drum socket. Remove and discard the old rope.

10) Place paper on floor to protect the new wire rope from dirt and grit. Stretch the new rope out on the paper with the sleeve fitting end toward the hoist. Relieve any twist in the new rope.

11) Insert the new rope's sleeve fitting into the drum socket, making sure the fitting is properly seated.

12) Push the "UP" button until about half of the new rope is wound onto the drum. Apply slight tension to the rope with a gloved hand to wind rope evenly on the drum.

13) Attach the dead end by placing the new rope's eye fitting over the anchor pin, while making sure there are no twists in the rope. Be sure to replace and tighten both anchor pin screws.

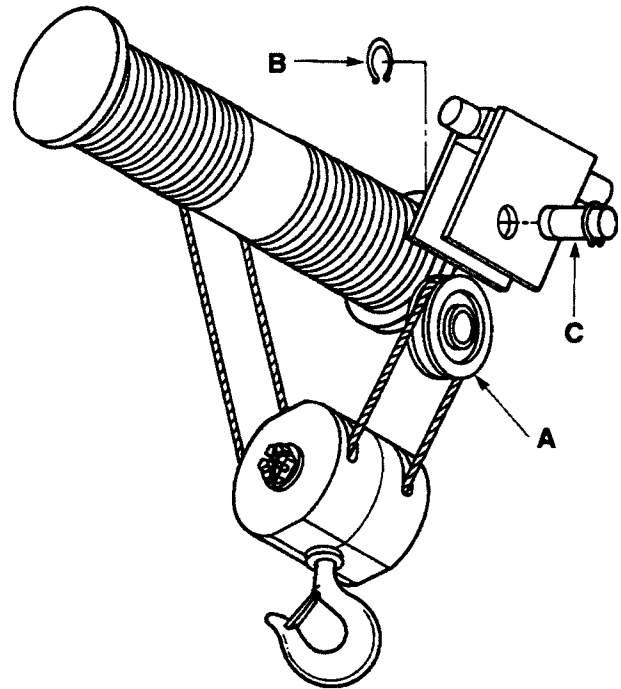
14) Reassemble the load block onto the new wire rope. See Figure 8-9A for aid in reassembly. Refer to Figure 5-3 to make sure that the rope is reeved correctly.

15) Adjust the limit switches per paragraph 5-2.

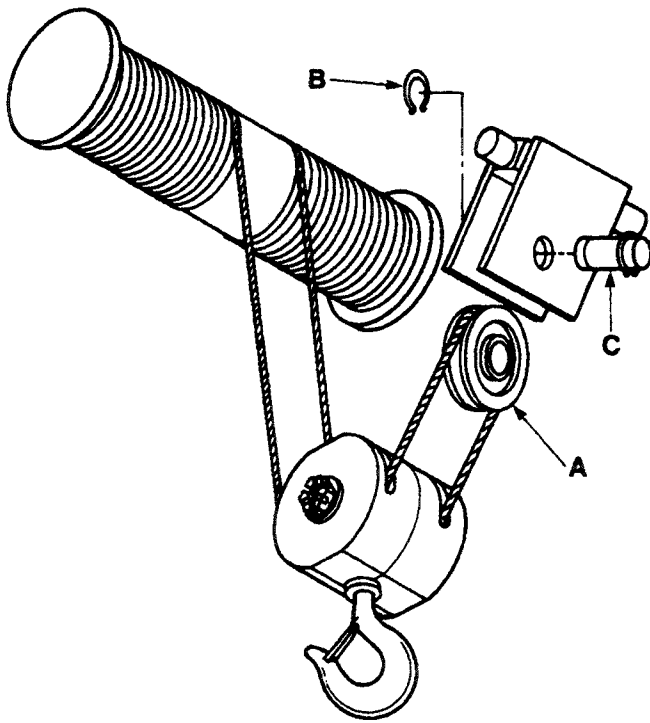
16) Lubricate the wire rope per paragraph 5-5a. Test the hoist and break-in the wire rope per paragraph 2-6b.

- b. **HOISTS REEVED TWO PART DOUBLE:**

Refer to Figures 5-4 or 5-5 for parts identification and proper rope reeving.

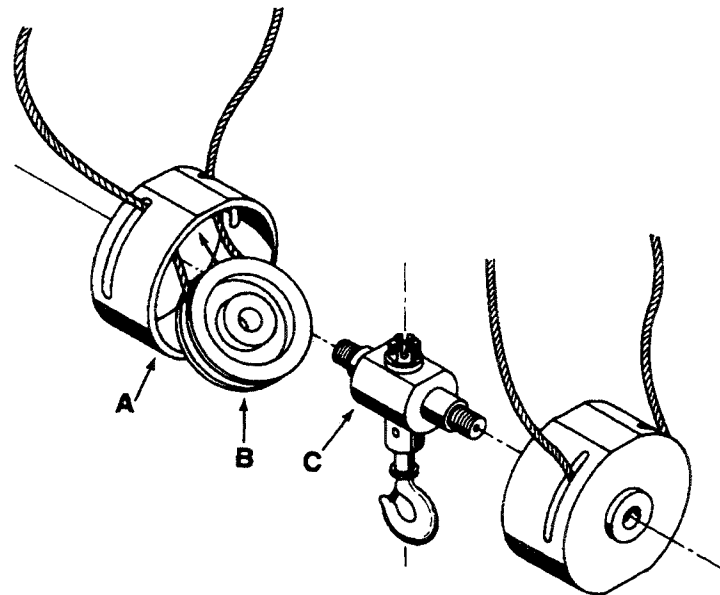


**FIGURE 5-4. TWO PART SINGLE REEVING:
TRUE VERTICAL LIFT MODELS**



**FIGURE 5-5. TWO PART SINGLE REEVING:
LOW HEADROOM MODELS**

- 1) Push "DOWN" button and run old rope out until stopped by lower limit switch.
- 2) Disassemble the load block by removing the spring pins (12, Figure 8-9B) and the slotted nuts (9, Figure 8-9B). The block covers (11, Figure 8-9B) will still be captured by the rope. Clean and inspect the hook, sheaves, bearings, and yoke for wear, damage, etc. Replace parts as necessary. Do not reassemble the load block yet.
- 3) **DISCONNECT POWER** from the hoist and remove the short end cover.
- 4) With a screwdriver, push the spring guide plate (1, Figure 5-1) out of the slots in the limit switch nuts. Turn the zinc slotted nut (3) back to about the center of the threaded screw. **DO NOT DISCONNECT THE WIRES FROM THE LIMIT SWITCHES.**
- 5) With the end cover off, connect hoist to power supply. Be sure the green wire is grounded.
- 6) Carefully jog the "DOWN" button until all the old rope is run off and the drum socket openings are accessible.
- 7) **DISCONNECT POWER** from the hoist.
- 8) Remove the equalizer sheave (A, Figure 5-4 or 5-5) by removing one retaining ring (B) and the sheave pin (C). Clean and inspect these parts.
- 9) Slide the sleeve fittings out of the drum sockets and out of the block covers. Remove and discard the old rope.
- 10) Place paper on floor to protect the new wire rope from dirt and grit. Stretch the new rope out in one length and relieve any twist. The double the rope by bringing the two sleeve fittings together.
- 11) Pass each sleeve fitting through the rope openings in the block covers only. The block should remain disassembled at this point.



**FIGURE 5-6. ASSEMBLY OF LOAD BLOCK —
TWO PART DOUBLE REEVED**

- 12) Insert each sleeve fitting into the drum sockets, making sure the fittings are properly seated.
- 13) Push the "UP" button until a few wraps of rope are wound onto the drum. Apply slight tension to the ropes with gloved hands to wind the rope evenly on the drum.
- 14) Place the looped end over the equalizer sheave and return the sheave to its frame. Reinstall the sheave pin and retaining ring.
- 15) At this point, only the block covers will be hanging from the two loops of rope.

- 16) Refer to Figure 5-6 for assembly of load block. Pull a loop of rope to the inside of the block cover (A), and place a sheave (B) in this loop. Angle the top of the sheave into the cover, while keeping the rope seated in the sheave groove. The sheave will now drop to the inside wall of the cover. Place the sheave and cover, as one unit, over the yoke (C), and hand-tighten the slotted nut. Repeat for the other side. Tighten both slotted nuts and install the spring pins. Refer to Figure 5-4 or 5-5 to make sure that the rope is reeved correctly.
- 17) Adjust the limit switches per paragraph 5-2.
- 18) Lubricate the wire rope for paragraph 5-5a. Test the hoist and break-in the wire rope per paragraph 2-6b.

5-5. Lubrication

Proper lubrication is necessary for long, trouble-free hoist operation. Refer to the following and to Table 5-1, Recommended Lubrication Schedule, for lubrication points, type of lubricant, and frequency of lubrication.

- a. **Wire Rope:** Lubrication of the wire rope is important. The action within the rope as it moves over the drum or around the sheave is for the strands to slide one against the other. Lubrication will reduce this friction and prevent the entrance

of moisture which can cause corrosion. Frequent light applications of lubricant are better than infrequent heavy applications. For best results, use Coffing Wire Rope Lubricant (Part No. 14J49), or other wire rope lubricant. As alternative, use SAE 30 motor oil.

- b. **Gearing:** The gear case of the hoist is filled at assembly with 46 oz. of a gear oil containing special friction-reducing additives.

WARNING

The use of gear oils other than that recommended in Table 5-1 can cause brake chatter or can render the load brake incapable of holding a load. A 46 oz. container of this oil is available from the Duff-Norton Co. (Part No. 14J1).

- a. To check the oil level, remove the 1/8" pipe plug from the side of the hoist. With the hoist hanging level, transmission oil should be even with the edge of the tapped plug hole.
- b. The length of time between necessary oil changes will depend on the severity of use the hoist receives. In general, the oil should be changed every 12 months of normal operation, or every 200 hours of actual hoist on-time. Very heavy use or

operation in high ambient temperatures (over 105°F) will require that oil be changed more often. An indication of the need for oil replacement is load brake noise. If an erratic tapping sound is made when lowering a load, the oil should be changed.

- c. **Limit Switch Shaft:** To prevent rust, the threaded limit switch shaft should be given a light coat of grease or sprayed with a general purpose lubricant.
- d. **Hook Bearing:** Apply a few drops of SAE 30 oil around the edge of the bearing.
- e. **Sheave Bearings:** At periodic inspections (see Figure 4-1), and when the wire rope is replaced, wash out the old grease with solvent and pack with new grease.
- f. **Trolley Gear Box:** At periodic inspections (see Figure 4-1) check grease level by removing end cap (22, Figure 8-11). The gear box should be approximately half full of grease. In general, the trolley gear box lubricant does not require changing.
- g. **Trolley Wheel Gears:** Apply a light coat of grease to the pinion and both gears.

TABLE 5-1. RECOMMENDED LUBRICATION SCHEDULE* MODEL WR-1 ELECTRIC WIRE ROPE HOIST

Figure And Index No.	Component	Type of Lubricant	Type of Service And Frequency of Lubrication		
			Heavy	Normal	Infrequent
Figure 8-5A, No. 17 Figure 8-5B, No. 44 Figure 8-5C, No. 26	Wire Rope	Coffing Wire Rope Lubricant (Kit No. 14J49 contains 8 fl. oz.) or SAE 30 Gear or Motor Oil	Daily	Weekly	Monthly
Figure 8-4	Hoist Gearing	Coffing No. H-7813 transmission oil (Kit No. 14J1 contains quantity of oil sufficient for one oil change)	At periodic inspection (see Figure 4-1, paragraph 5-5b)		
Figure 8-6, No. 9	Limit Switch Shaft	"WD-40" or general purpose spray lubricant.	Monthly	Yearly	Yearly
Figure 8-9A, No. 11 Figure 8-9B, No. 5	Load Hook Bearing	SAE 30 Gear or Motor Oil	Weekly	Monthly	Yearly
Figure 8-9A, No. 7 Figure 8-9B, No. 3	Sheave Bearings	NLGI #2 multipurpose lithium-base grease. (Coffing No. H-7610)	At periodic inspection (see Figure 4-1)		
Figure 8-11	Trolley Gear Box	NLGI #2EP lithium-base grease. (Coffing No. H-7610)	At periodic inspection (see Figure 4-1)		
Figure 8-10A, No. 17 Figure 8-10B, No. 23	Trolley Wheel Gears	NLGI #2 multipurpose lithium-base grease (Coffing No. H-7610)	Weekly	Monthly	Yearly

NOTE: All bearings except hook and sheave bearings are prelubricated and sealed.

*This lubrication schedule is based on a hoist operating in normal environmental conditions. Hoists operating in adverse atmospheres containing excessive heat, corrosive fumes or vapors, abrasive dust, etc., should be lubricated more frequently.

SECTION VI TROUBLESHOOTING

6-1. General

Use the following table as an aid to troubleshoot your hoist. If you do not have an experienced machinist-electrician to

do your repair work, we recommend that you send your hoist to an approved service center for repairs.

TROUBLE	REMEDY
---------	--------

Hook Fails to Stop at End of Travel.

<ol style="list-style-type: none"> 1. Limit switches not operating. 2. Limit switch nuts not moving on shaft. 3. Magnetic reversing switch malfunction. 	<ol style="list-style-type: none"> 1. Check adjustment. See paragraph 5-2. Check connections against wiring diagram. Tighten loose connections or replace. 2. Check for stripped threads or bent nut guide. 3. Remove electrical cover and check reversing switch.
--	---

Hoist Does Not Respond to Pushbutton.

<ol style="list-style-type: none"> 1. Power failure in supply lines. 2. Wrong voltage or frequency. 3. Improper connections in hoist or pushbutton station. 4. Motor brake does not release. 5. Faulty magnetic hoist control switch. 	<ol style="list-style-type: none"> 1. Check circuit breakers, switches and connections in power supply lines. 2. Check voltage and frequency of power supply against the rating on the nameplate of the hoist. 3. Check all connections at line connectors and on terminal block. Check terminal block on dual-voltage hoists for proper voltage connections. 4. Check connections to the solenoid coil. Check for open or short circuit. Check for proper adjustment. See paragraph 5-3. 5. Check coils for open or short circuit. Check all connections in control circuit. Check for burned contacts. Replace as needed.
--	--

Hook Does Not Stop Promptly.

<ol style="list-style-type: none"> 1. Hoist overloaded. 2. Brake not holding. 	<ol style="list-style-type: none"> 1. Reduce load to within rated capacity of hoist. 2. Check motor brake adjustment (see paragraph 5-3) and load brake (Figure 4-4).
---	---

Hook Moves in Wrong Direction.

<ol style="list-style-type: none"> 1. Three-phase reversal. 2. Improper connections. 	<ol style="list-style-type: none"> 1. Reverse any two wires (except the green ground wire) at the power source (see paragraph 2-3). 2. Check all connections against Wiring Diagram.
--	--

Hoist Hesitates to Lift When Energized.

<ol style="list-style-type: none"> 1. Hoist overloaded. 2. Motor brake requires adjustment. 3. Worn overload limiting clutch. 4. Low voltage. 5. Faulty SINPAC starting switch or start capacitor (single phase hoists only). 	<ol style="list-style-type: none"> 1. Reduce load within rated capacity of hoist. 2. Check motor brake adjustment. See Figure 5-3. 3. Replace clutch. 4. Check voltage at hoist power cord with hoist starting. Voltage should be no less than 90% of voltage specified on hoist. 5. Replace faulty component.
--	---

Hook Raises But Will Not Lower. (Motor not running)

<ol style="list-style-type: none"> 1. "Down" circuit open. 2. Broken conductor in pushbutton cable. 3. Faulty magnetic hoist control switch. 	<ol style="list-style-type: none"> 1. Check circuit for loose connections. Check "Down" limit switch for malfunction. 2. Check each conductor in the cable. If one is broken, replace entire cable. 3. Check coils for open or short circuit. Check all connections in control circuit. Check for burned contacts. Replace as needed.
---	--

TROUBLE**REMEDY****Hook Raises But Will Not Lower When Motor Is Operating.**

Consult Factory Or Authorized Duff-Norton Warranty Repair Station.
--

Hook Lowers But Will Not Raise.

<ol style="list-style-type: none"> 1. Hoist overloaded. 2. Low voltage. 3. "UP" circuit open. 4. Broken conductor in pushbutton cable. 5. Faulty magnetic hoist control switch. 6. Faulty capacitor (single-phase hoists only). 7. Worn overload limiting clutch. 	<ol style="list-style-type: none"> 1. Reduce load to within rated capacity. 2. Determine cause of low voltage and bring up to at least 90% of the voltage specified on hoist. Line voltage should be measured while holding or lifting load. 3. Check circuit for loose connections. Check "UP" limit switch for malfunction. 4. Check each conductor in the cable. If one is broken, replace entire cable. 5. Check coils for open or short circuit. Check all connections in control circuit. Check for burned contacts. Replace as needed. 6. Check starting capacitor in motor. Replace if necessary. 7. Replace clutch.
--	---

Lack Of Proper Lifting Speed.

<ol style="list-style-type: none"> 1. Hoist overloaded. 2. Motor brake is dragging. 3. Low voltage. 4. Overload limiting clutch intermittently slipping. 	<ol style="list-style-type: none"> 1. Reduce load to within rated capacity of hoist. 2. Check for proper brake adjustment or other defects. See paragraph 5-3. 3. Bring up voltage to plus or minus 10% of voltage specified on hoist. Line voltage should be measured while hoist is lifting load. 4. Replace clutch.
--	--

Load Brake "Noise." (Erratic tapping sounds or squeals)

<ol style="list-style-type: none"> 1. Need transmission oil change or improper lubricant has been used. 2. Load brake malfunctioning. 	<ol style="list-style-type: none"> 1. Change transmission oil. See Table 5-1. Note: Hoist Warranty is void if unapproved oil is used. 2. Check load brake operation. See paragraph 4-4.
---	---

Motor Brake Noise Or Chatter. (While starting hoist)

<ol style="list-style-type: none"> 1. Brake needs adjustment. 2. Low voltage. 	<ol style="list-style-type: none"> 1. Adjust as per paragraph 5-3. 2. Check voltage at hoist power cord with hoist starting. Voltage should be no less than 90% of the voltage specified. 115 volt hoists are particularly subject to voltage drop problems due to their high current draw. Conversion to 230 volt operation is suggested in extreme cases.
---	---

Motor Brake "Buzz." (Anytime hoist is running)

<ol style="list-style-type: none"> 1. Brake needs adjustment. 2. Broken shading coil on brake frame. 	<ol style="list-style-type: none"> 1. Adjust as per paragraph 5-3. 2. Replace shading coil or complete brake frame assembly.
--	--

SECTION VII

WIRING

Safety Notes

Disconnect power from hoist before removing end covers.

7-1. Voltage Conversion

Standard single phase units are convertible from 115 to 230 volts and standard single speed three phase units are convertible from 460 to 230 volts. Conversion to the alternate voltage can be accomplished with the following procedure.

- a. Be sure power is disconnected from hoist. Remove long end cover.
- b. **SINGLE PHASE HOISTS (With SINPAC™ switch):** Transfer leads 2, H2, H3, T2, S1, and T3 per the appropriate terminal block schematic.

- c. **THREE PHASE HOISTS:** Transfer leads T4, T5, T6, T7, T8, T9, H2, H3, S1, and S2 per the appropriate terminal block schematic.

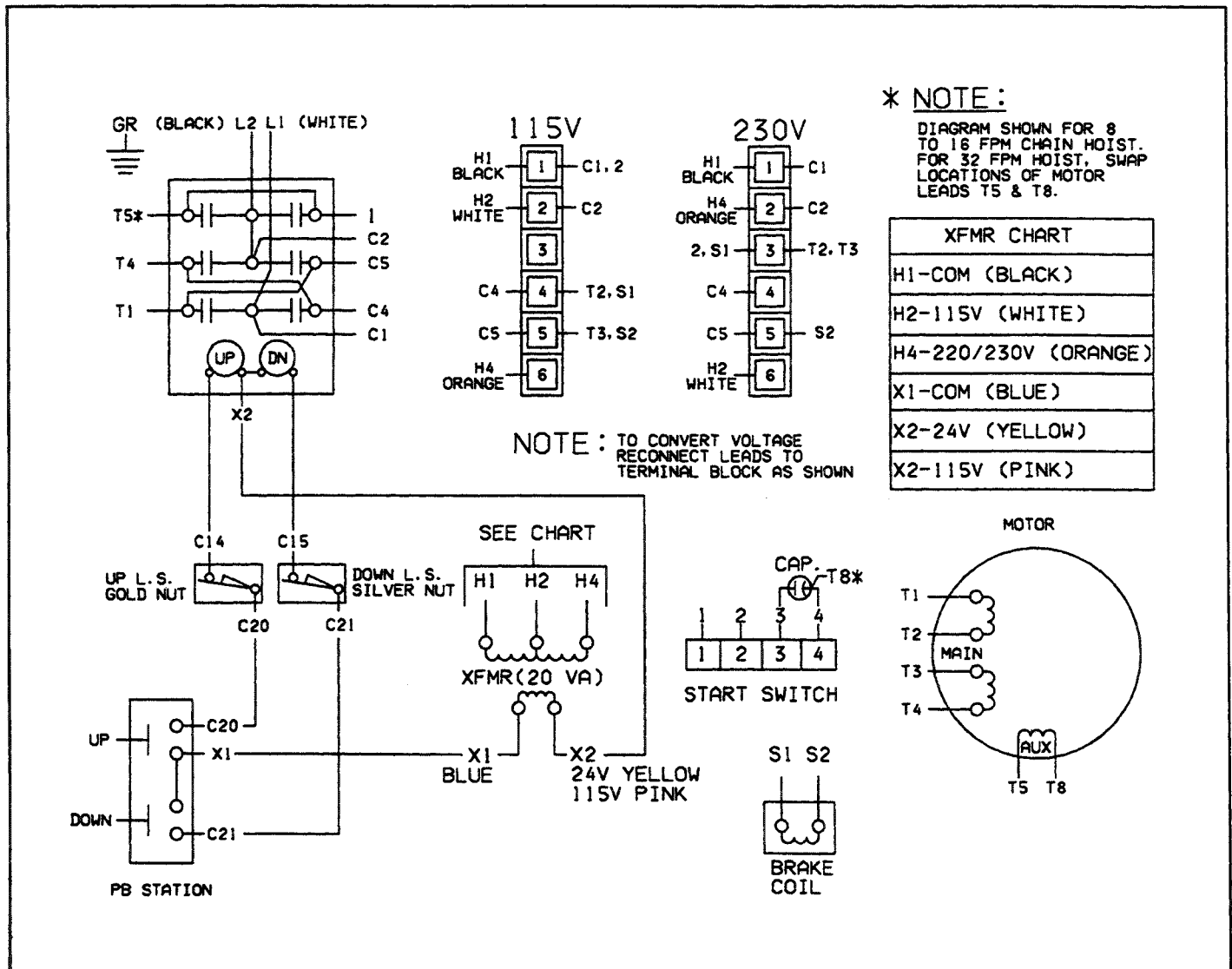
CAUTION

Do not move any wires or make any changes to the wiring except at the terminal block.

- d. After converting voltage, check for proper phasing of three phase units and check for proper limit switch operation.

7-2. Wiring Diagrams

The wiring diagrams for standard hoist models are reproduced on the following pages. In addition, every hoist should have a wiring diagram located inside the long end cover.



**FIGURE 7-1. WIRING DIAGRAM
 115/230V, 1 Phase, Single Speed Hoist
 with SINPAC Switch**

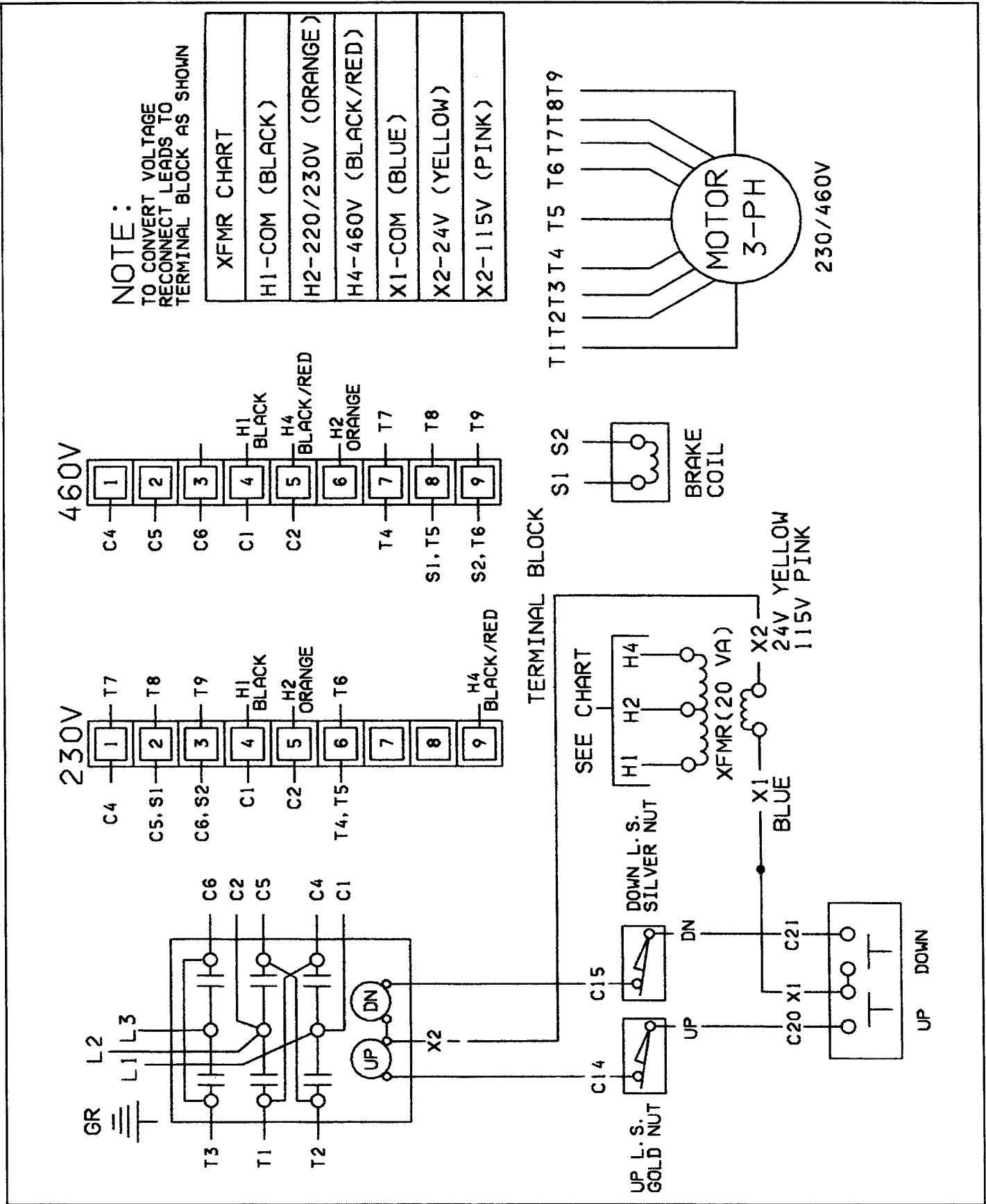


FIGURE 7-2. WIRING DIAGRAM
230/460V, 3 Phase, Single Speed Hoist

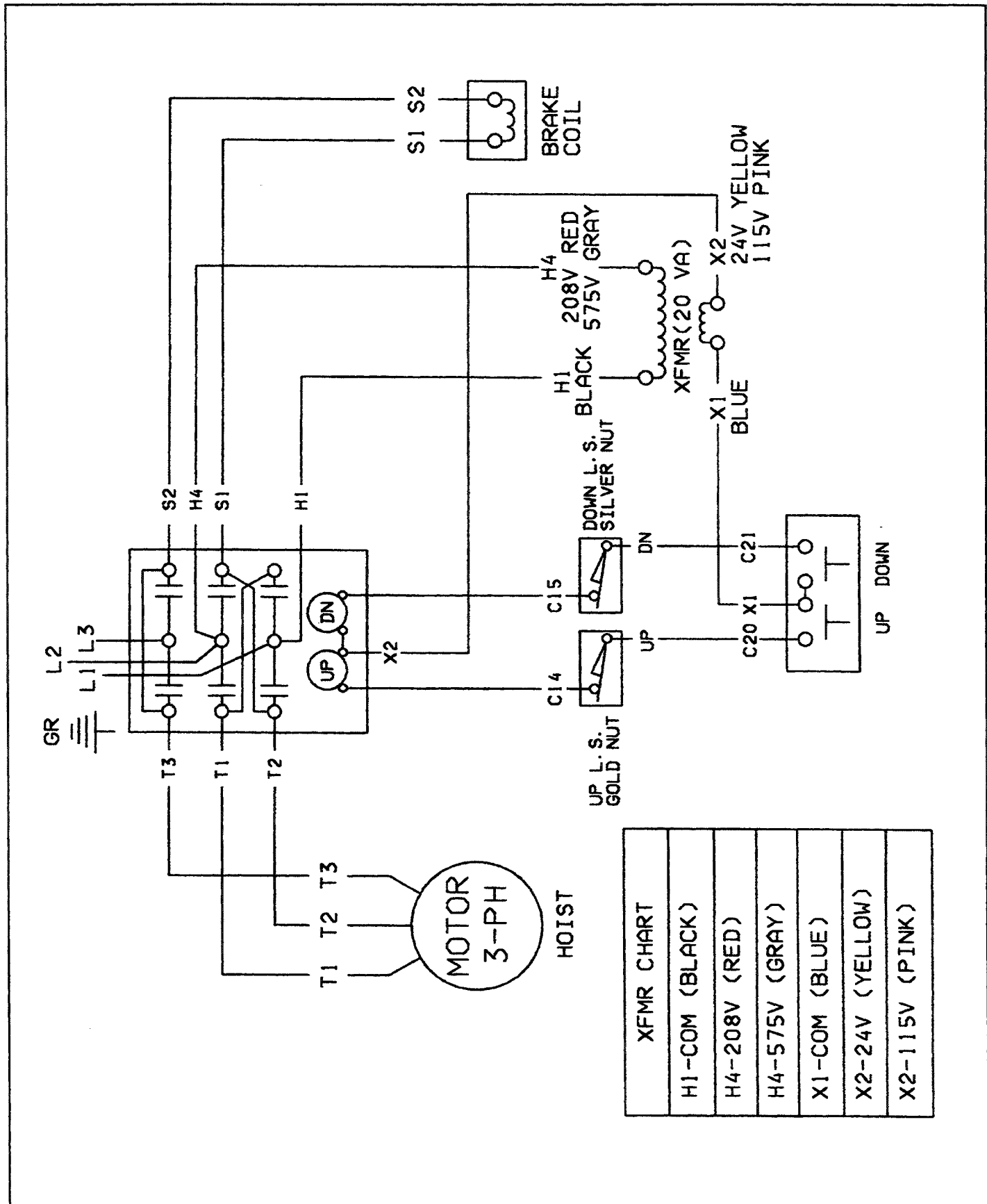


FIGURE 7-3. WIRING DIAGRAM
208V or 575V, 3 Phase, Single Speed Hoist

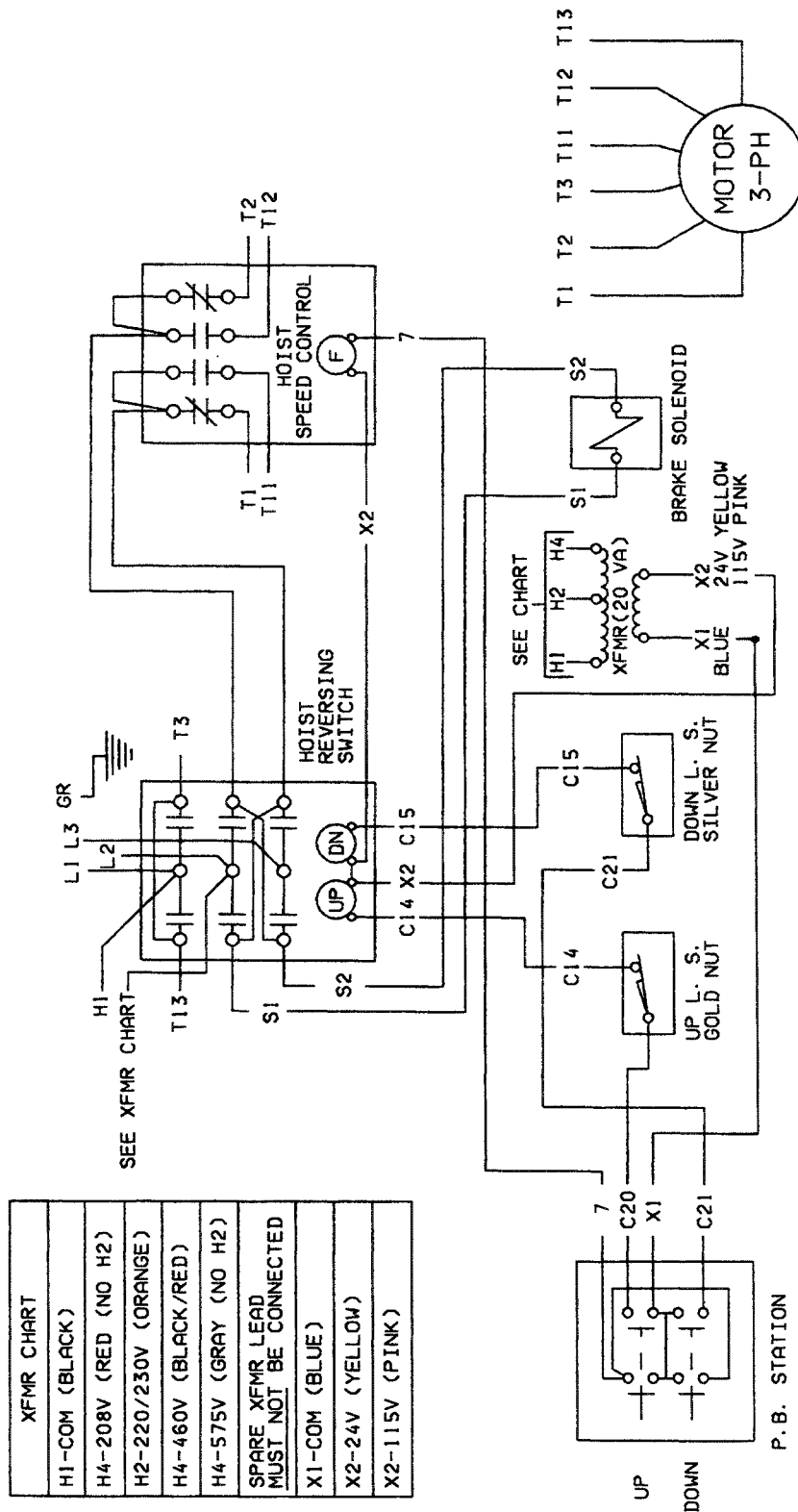
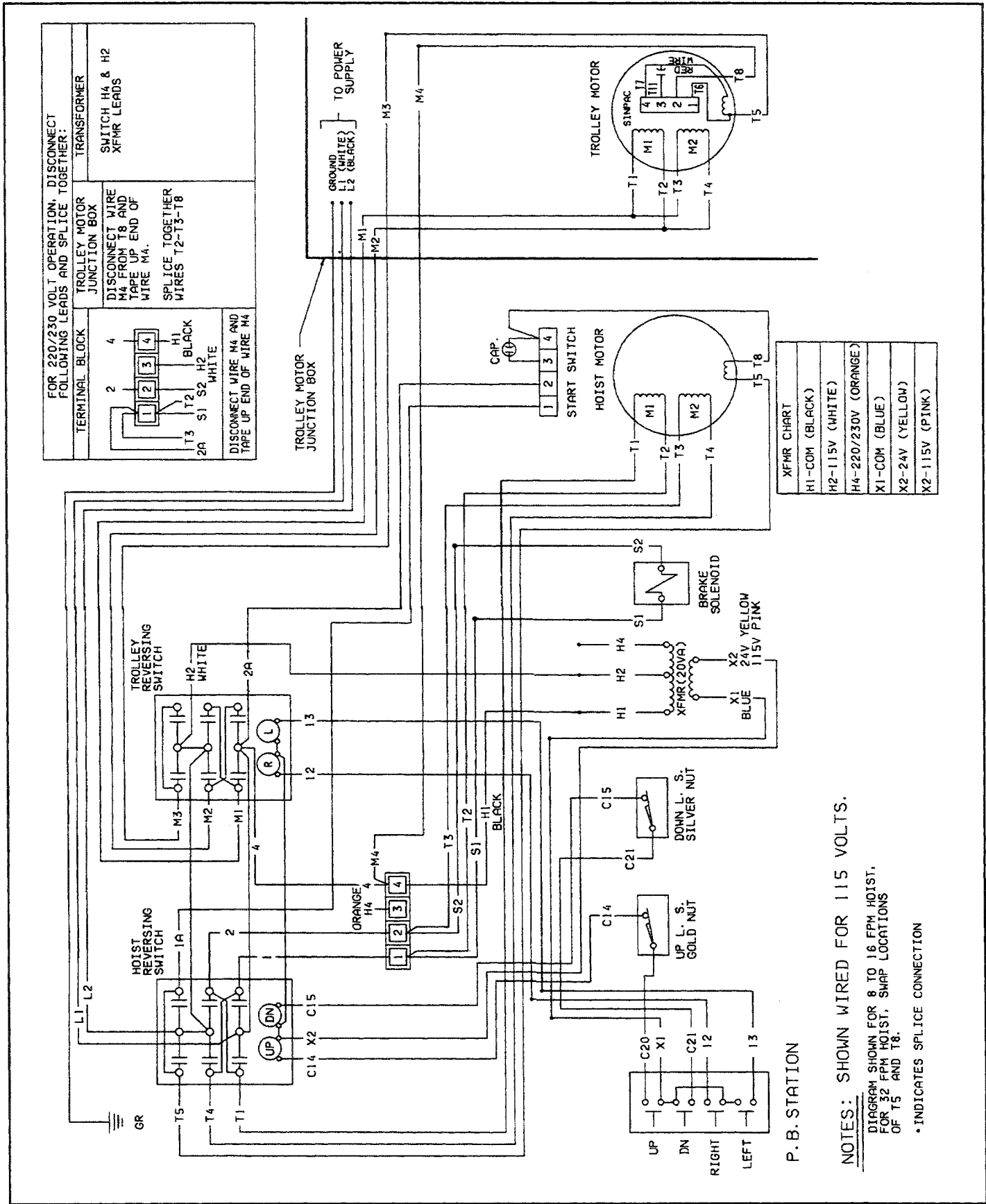


FIGURE 7-4. WIRING DIAGRAM
208V, 230V, 460V or 575V, 3 Phase, Two Speed Hoist



NOTES: SHOWN WIRED FOR 115 VOLTS.

DIAGRAM SHOWN FOR 8 TO 16 FPM HOIST, FOR 32 FPM HOIST, SWAP LOCATIONS OF T5 AND T8.

• INDICATES SPLICE CONNECTION

FIGURE 7-5. WIRING DIAGRAM
115/230V, 1 Phase, Single Speed Hoist & Single Speed Trolley

SPLICE CONNECTIONS		
HOIST	460V	TROLLEY
220/230V	208/575V	208-230V
T1-T1-S1	T1	M1-T1-T1
T2-T2-S2	T2	M2-T2-T2
T3-T3	T3	M3-T3-T3
T4-T5-T6	(NO T4-T5)	T4-T5-T6
T5-T8-S1		T5-T8
T6-T9-S2		T6-T9

XFMR CHART	
H1-COM	(BLACK)
H4-208V	(RED (NO H2))
H2-220/230V	(ORANGE)
H4-460V	(BLACK/RED)
H4-575V	(GRAY (NO H2))
SPARE XFMR LEAD MUST NOT BE CONNECTED	
X1-COM	(BLUE)
X2-24V	(YELLOW)
X2-115V	(PINK)

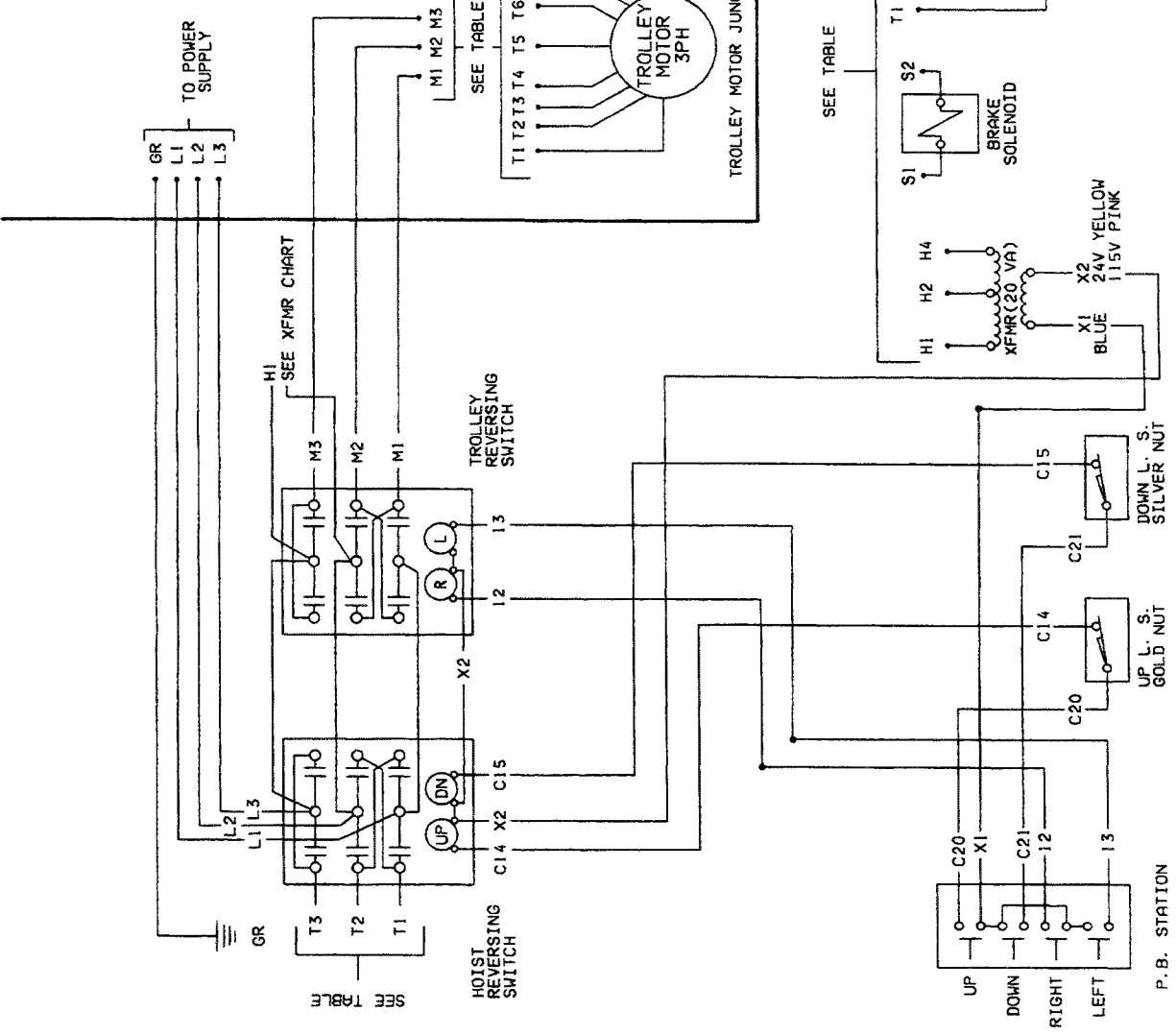


FIGURE 7-6. WIRING DIAGRAM
208V, 230/460V or 575V, 3 Phase
Single Speed Hoist & Single Speed Trolley

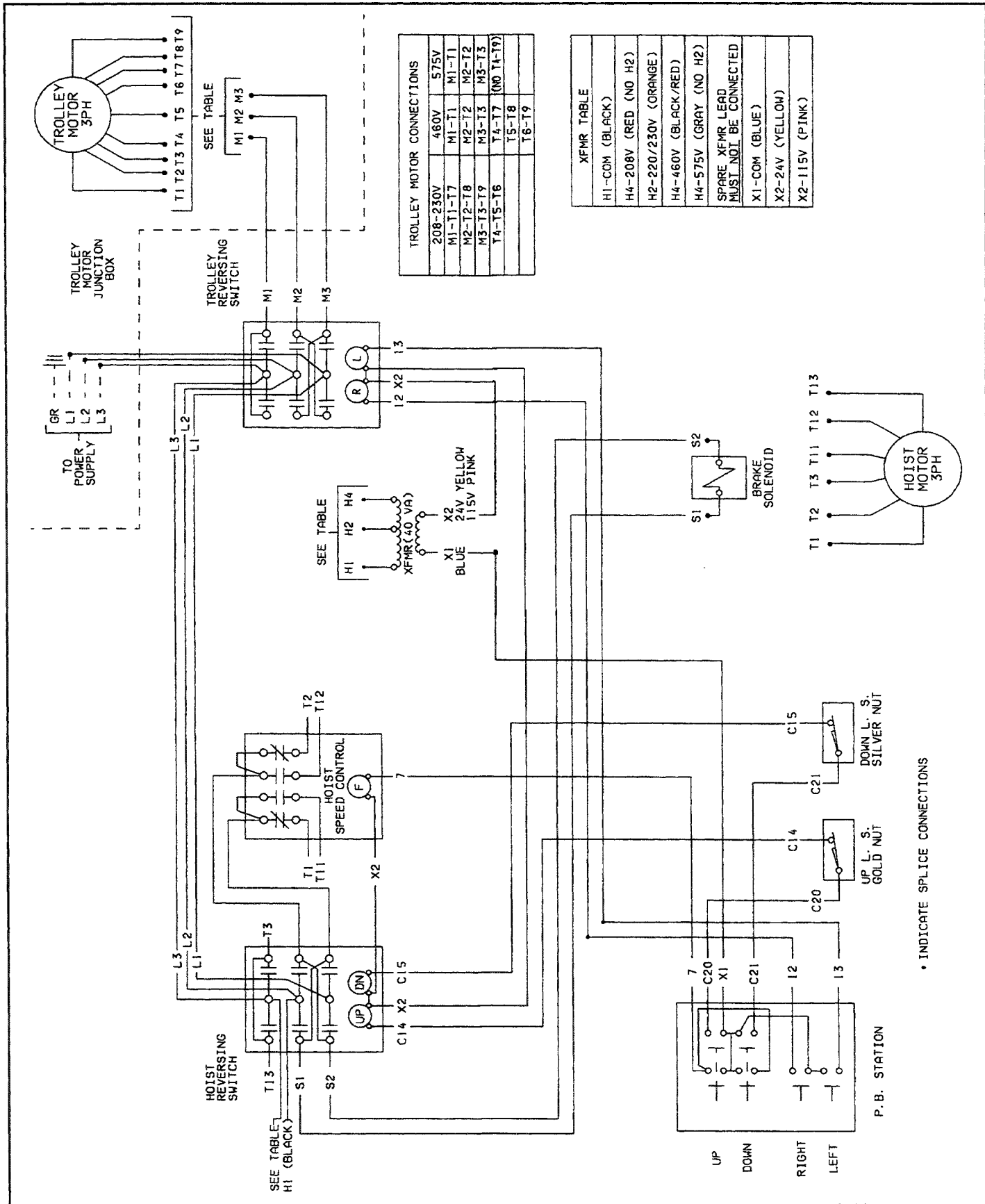


FIGURE 7-7. WIRING DIAGRAM
208V, 230V, 460V or 575V, 3 Phase
Two Speed Hoist & Single Speed Trolley

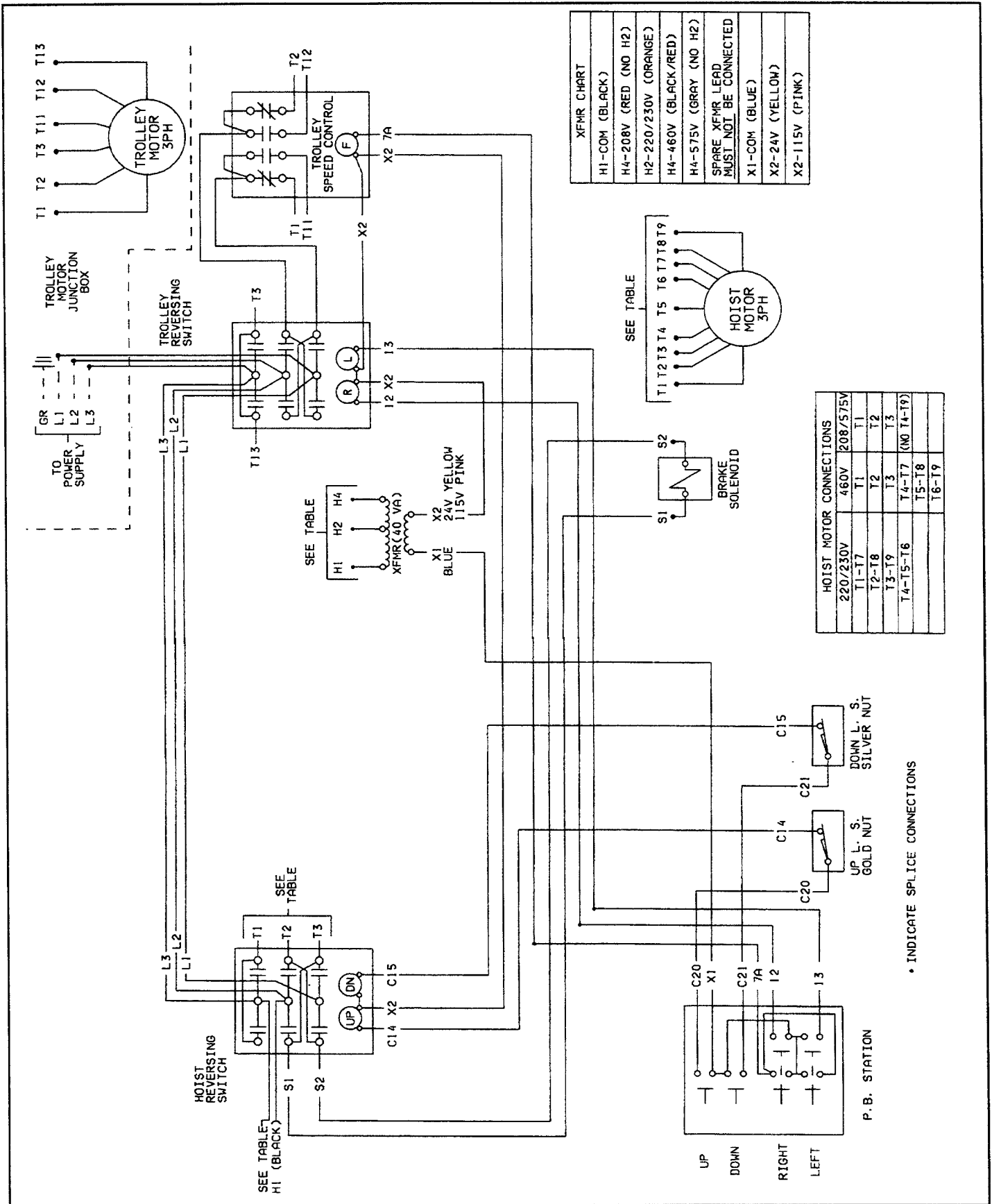


FIGURE 7-8. WIRING DIAGRAM
208V, 230V, 460V or 575V, 3 Phase
Single Speed Hoist & Two Speed Trolley

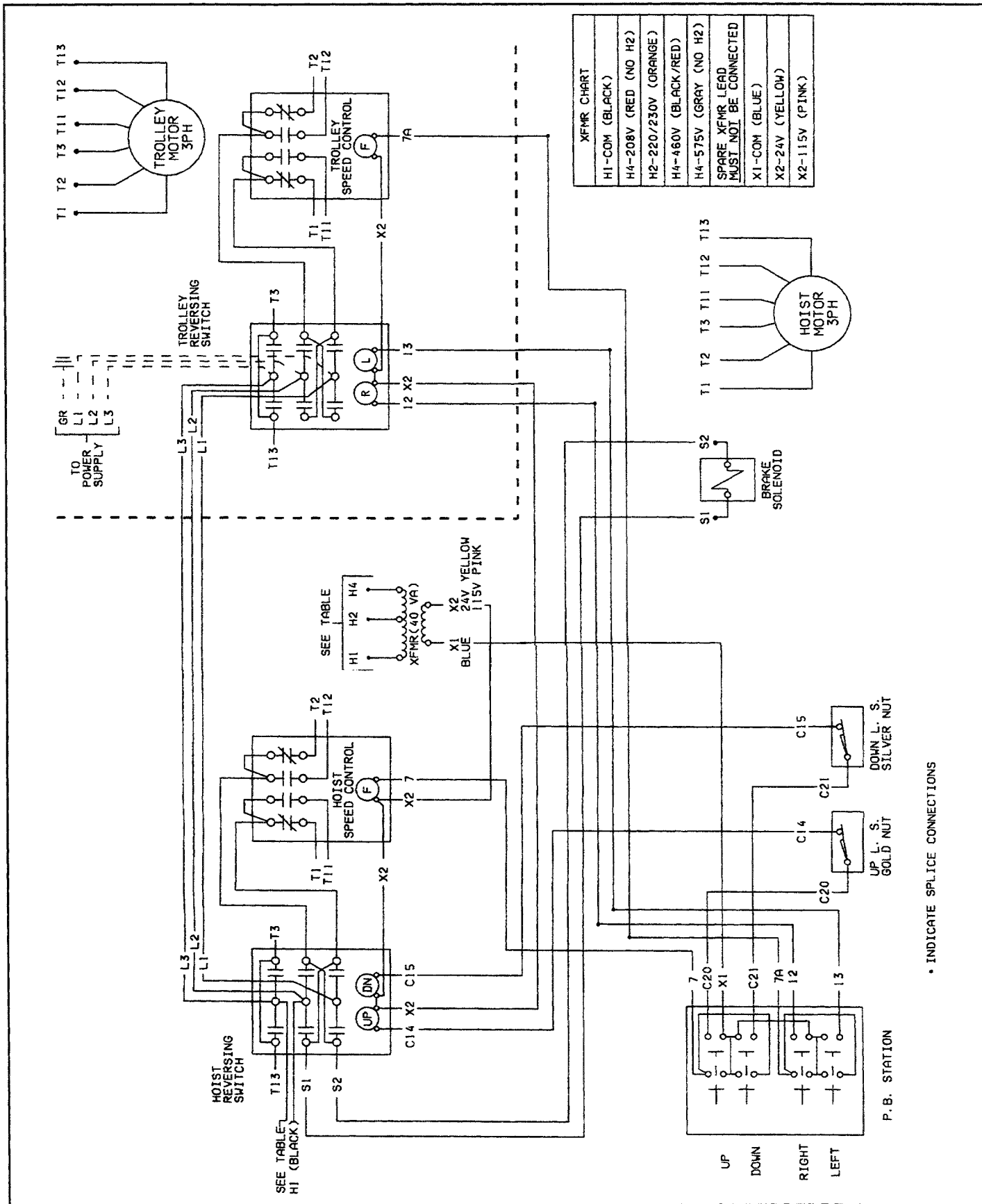


FIGURE 7-9. WIRING DIAGRAM
208V, 230V, 460V or 575V, 3 Phase
Two Speed Hoist & Two Speed Trolley

SECTION VIII

ILLUSTRATED PARTS LIST

8-1. General

The following exploded drawings provide a complete list of parts used in the standard WR-1 hoist models (shown in Table 1-1, page 3). Since several different models of hoists are covered by this manual, differences may be noted between the appearance of your hoist part and the reference illustration. If this is the case, the parts list will show several different part numbers with sufficient information to allow the selection of the correct part number.

8-2. How To Use The Parts List

The parts list consists of three columns as follows:

- 1) Index Number
 - 2) Part Name, and additional descriptions which are essential for choosing the correct part number when more than one is listed.
 - 3) Part Number
- b. How to determine proper part number.
- 1) Locate the index number in the corresponding figure of the parts list.
 - 2) If only one part number is listed for the index number, that part number should be ordered.
 - 3) If more than one part number is listed, the information under "part name" will determine the correct part number.

EXAMPLE

Index No.	Part Name	Part No.
5	Transformer: (1 PH) Pri . 115/230V, Sec . 24V, 50/60 Hz	JL-821-212
	Pri. 115/230V, Sec. 115V, 50/60 Hz	JL-821-211

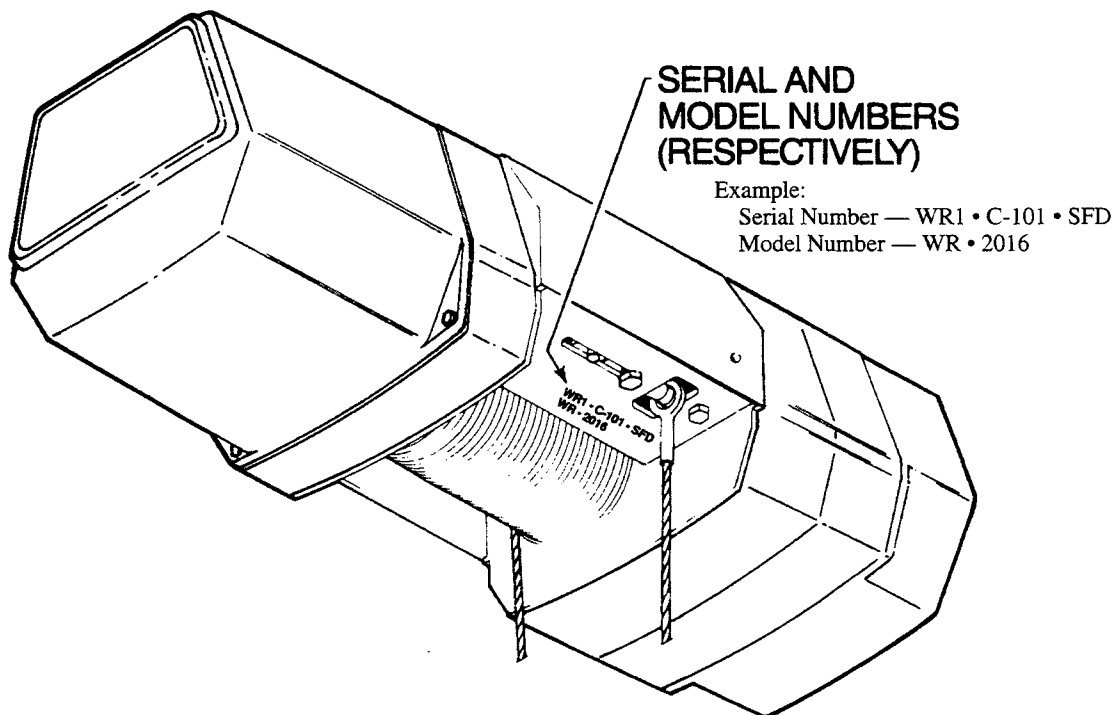
8-3. How To Order Replacement Parts

When ordering parts or requesting information concerning your WR-1 hoist, always include the hoist model number and serial number. Both numbers are permanently stamped on the bottom of the center frame, on the rectangular tube member.

When ordering motor parts, please provide complete motor nameplate data, including motor "ref." number or model number.

NOTE

Repair parts are available only from Coffing distributors or authorized repair facilities. It is recommended that repair part orders be directed to the authorized repair facility near you.



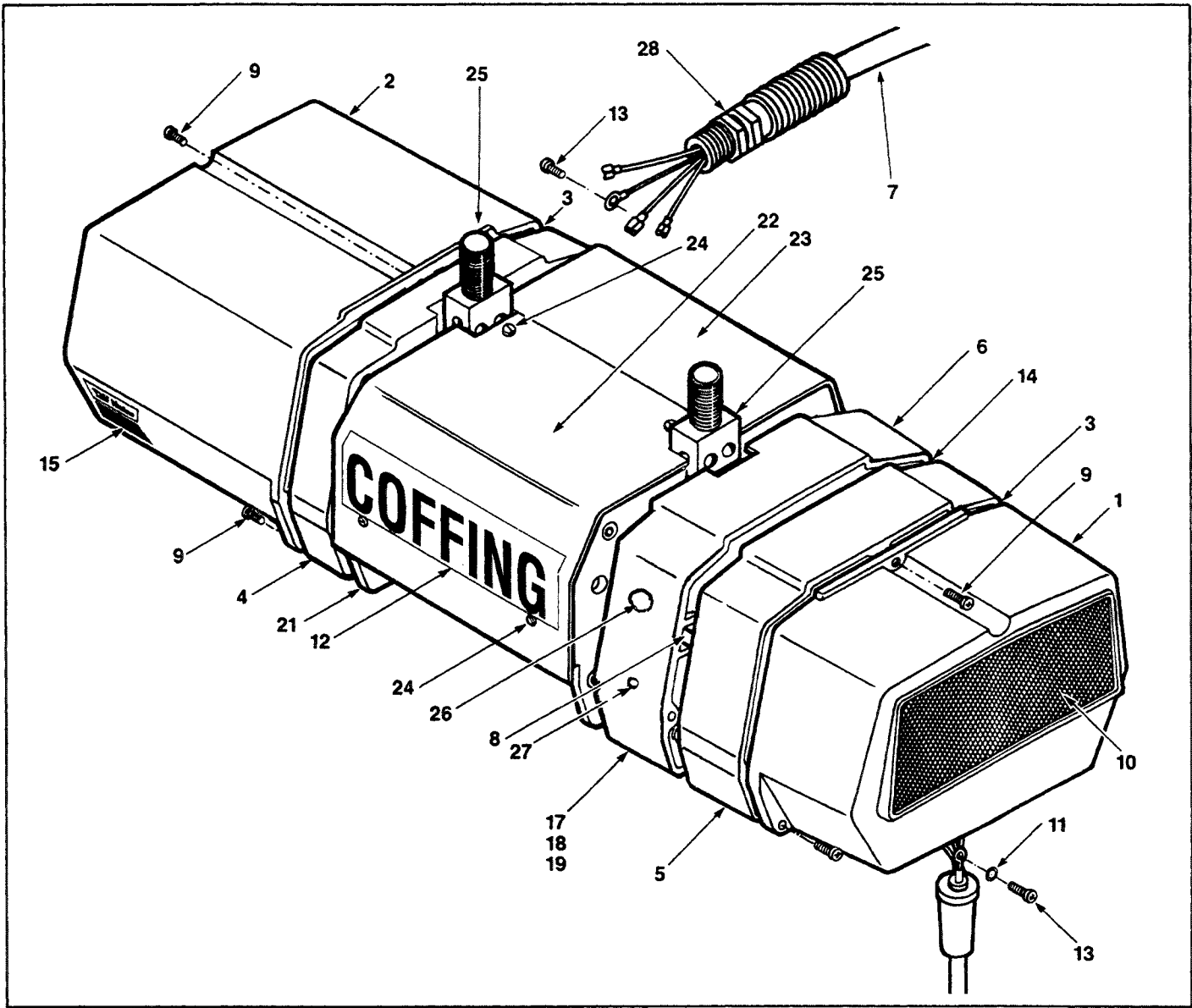


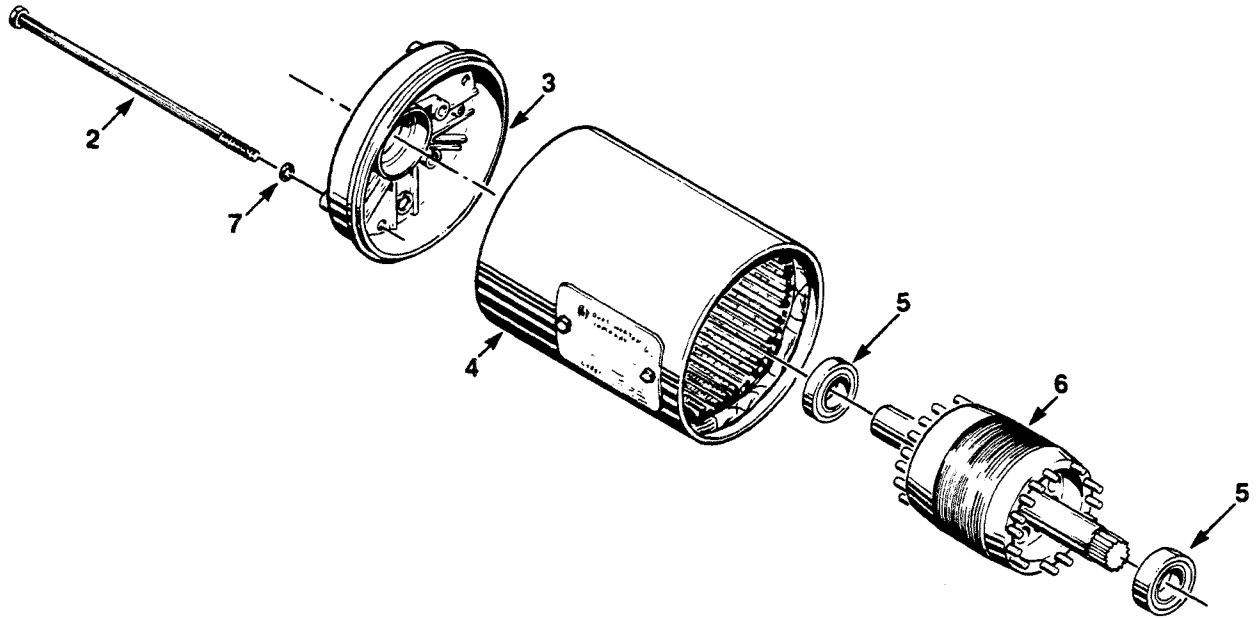
FIGURE 8-1. BASIC HOIST

Index No.	Part Name	Part No.
1	Brake Cover	36J1
2	Electrical Cover	36J2
3	Gasket Cover	560J4
4	Motor Adapter:	
	WR-1010	39J3-1
	WR-1016	39J3-1
	WR-1021	39J3
	WR-1032	39J3
	WR-2010	39J3-1 (Single Speed)
	WR-2010	39J3 (Two Speed & 1 Phase)
	WR-2016	39J3
5	Transmission Cover	34J16
6	Transmission Housing	35J6
7	Power Cables:	
	1 Phase	951KG1-15
	3 Phase	953KG1-15
8	Wiring Harness:	
	15 ft. Lift, Single Speed Hoist	940J5
	15 ft. Lift, Two Speed Hoist	940J5-1
	25 ft. Lift, Single Speed Hoist	940J6
	25 ft. Lift, Two Speed Hoist	940J6-1
	Lifts Greater Than 25 Ft.	Consult Factory
9	Screw, End Covers	H-2923-P
10	Decal, Capacity:	
	1/2 Ton	675J2-B
	1 Ton	675J3-B
11	Flat Washer	H-4002-P
12	Decal, Coffing	677J2
13	Screw	H-2981-P

Index No.	Part Name	Part No.
14	Gasket, Transmission	560J5
15	Decal	676J2-B
16*	Decal, Power Requirements:	
	115/230 Volt, 1 Phase	679J1
	230/460 Volt, 3 Phase	679J2
	230 Volt, 3 Phase	679J3
	460 Volt, 3 Phase	679J4
	575 Volt, 3 Phase	679J5
	208 Volt, 3 Phase	679J36
21	Suspension Assembly:	
	15 ft. Lift	33JG14-1
	25 ft. Lift	33JG15-1
	35 ft. Lift	33JG26-4
	50 ft. Lift	33JG26-2
	65 ft. Lift	33JG26-3
22	Cover:	
	15 ft. Lift	270J1-1
	25 ft. Lift	270J1-2
	Lifts Greater Than 25 ft.	Not Available
23	Cover:	
	15 ft. Lift	270J2-1
	25 ft. Lift	270J2-2
	Lifts Greater Than 25 ft.	Not Available
24	Screw, Covers	H-2970
25	Suspension Lug:	
	1 5 ft. Lift	50J31-1
	25, 35, 50 & 65 ft. Lift	50J48
26	Fill Plug, Vented	H-6258
27	Level Plug	S-25-13
28	Cord Grip	H-7641
29	Label (Lug Mount Unit Only)	687K9

* Not illustrated.

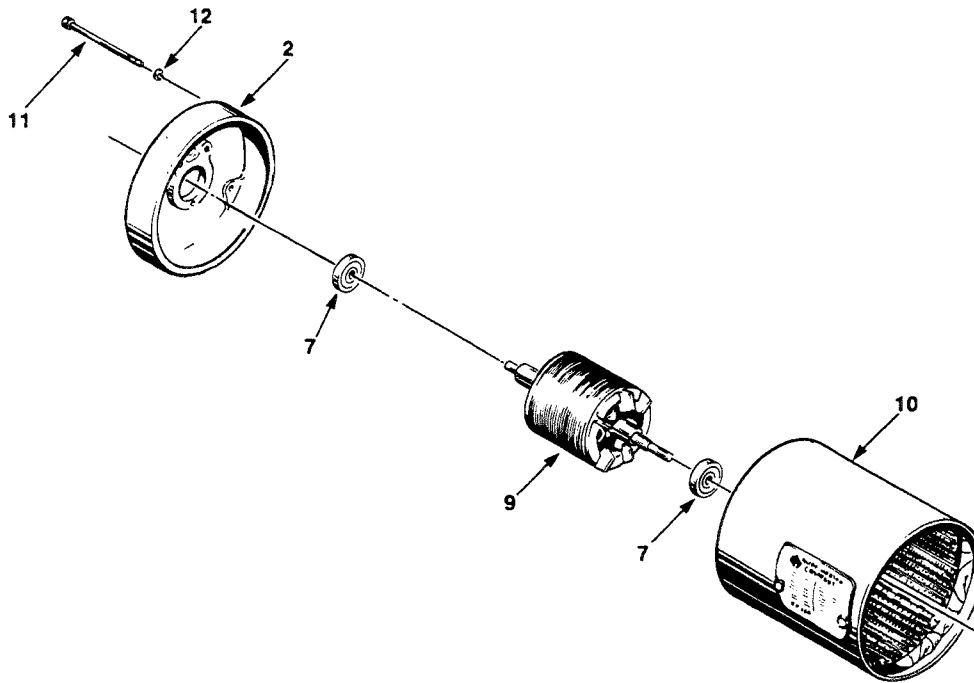
FIGURE 8-1. BASIC HOIST



Index No.	Part Name	Part No.
1	Motor, Complete (1/2 HP):	
	WR-1010	
	WR-1016	
	Single Speed - 230/460V	863J202
	Single Speed - 575V	863J205
	Single Speed - 208V	863J208
	Two Speed - 230V	873J202
	Two Speed - 460V	873J205
	Two Speed - 575V	873J208
	Two Speed - 208V	873J209
	Motor, Complete (1 HP):	
	WR-1032	
	WR-2016	
	Single Speed - 230/460V	863J104
Single Speed - 575V	863J108	
Single Speed - 208V	863J109	
Two Speed - 230V	873J104	
Two Speed - 460V	873J108	
Two Speed - 575V	873J112	
Two Speed - 208V	873J115	

Index No.	Part Name	Part No.
	Motor, Complete (3/4 HP):	
	WR-1021	
	WR-2010	
	Single Speed 230/460V	863J203
	Single Speed 575V	863J206
	Single Speed 208V	863J209
	Two Speed 230V	873J103
	Two Speed 460V	873J107
	Two Speed 575V	873J111
	Two Speed 208V	873J116
2	Thru Bolt	Contact Factory with Length Required.
3	End Shield	Contact Factory.
4	Stator	Not Available Separately.
5	Bearing	500K3
6	Rotor and Shaft Assembly	Contact Factory with Complete Motor Nameplate Data for Availability.
7	Lock Washer	H-4082-P

FIGURE 8-2A. HOIST MOTOR PARTS (3 PHASE)

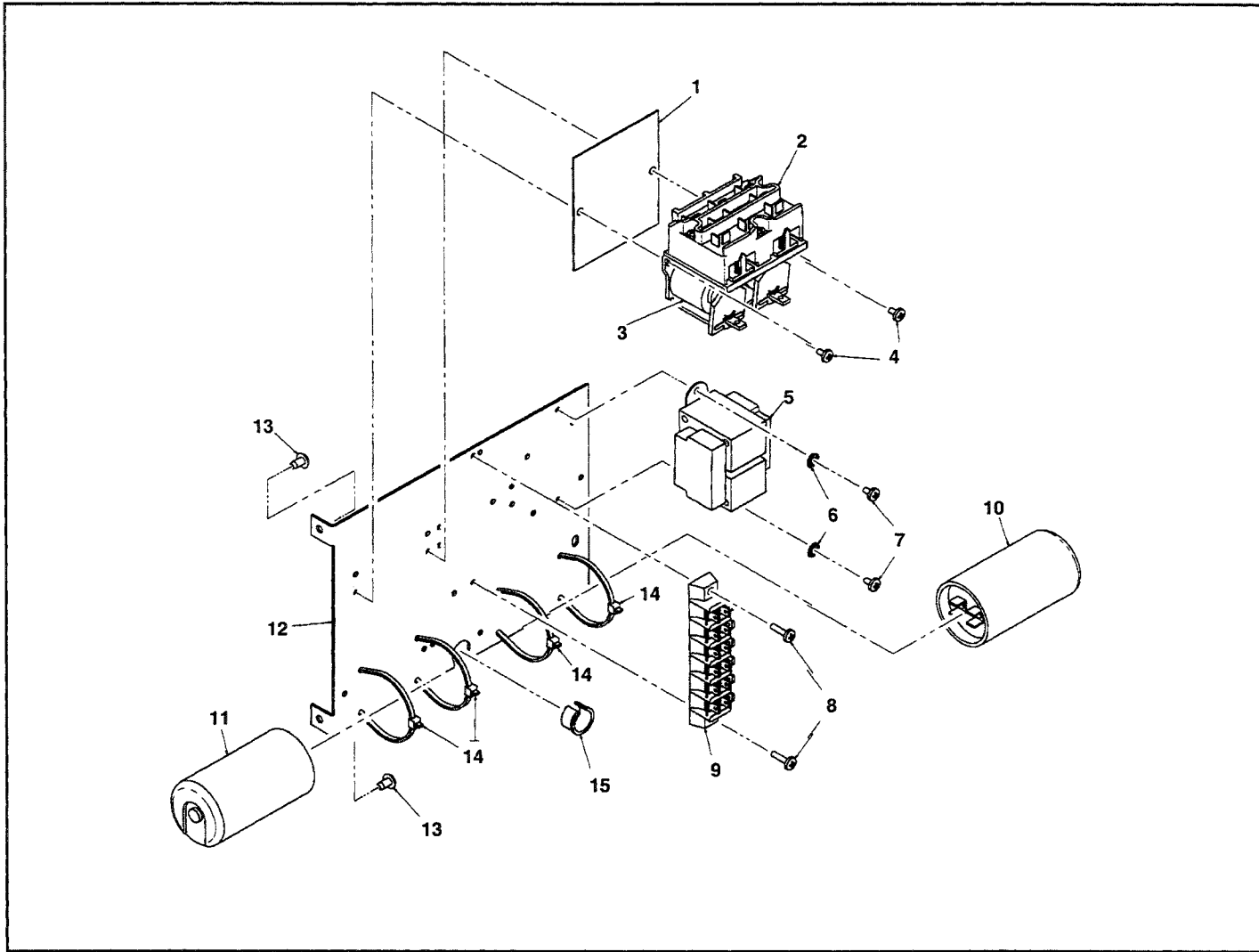


PARTS LIST FOR SINGLE PHASE HOIST MOTOR (SINPAC® SWITCH)

Index No.	Part Name	Part No.
1	Motor, Complete: 1/2 HP, 115/230 Volt 1 HP, 115/230 Volt 3/4 HP, 115/230 Volt	861J222 861J124 861J123
2	End Shield	Contact Factory
7	Bearing	500K3
9	Rotor & Shaft	Contact Factory with complete nameplate data for availability.

Index No.	Part Name	Part No.
10	Stator	Not available separately.
11	Thru Bolt	Contact Factory with Length Required.
12	Lockwasher	H-4082-P

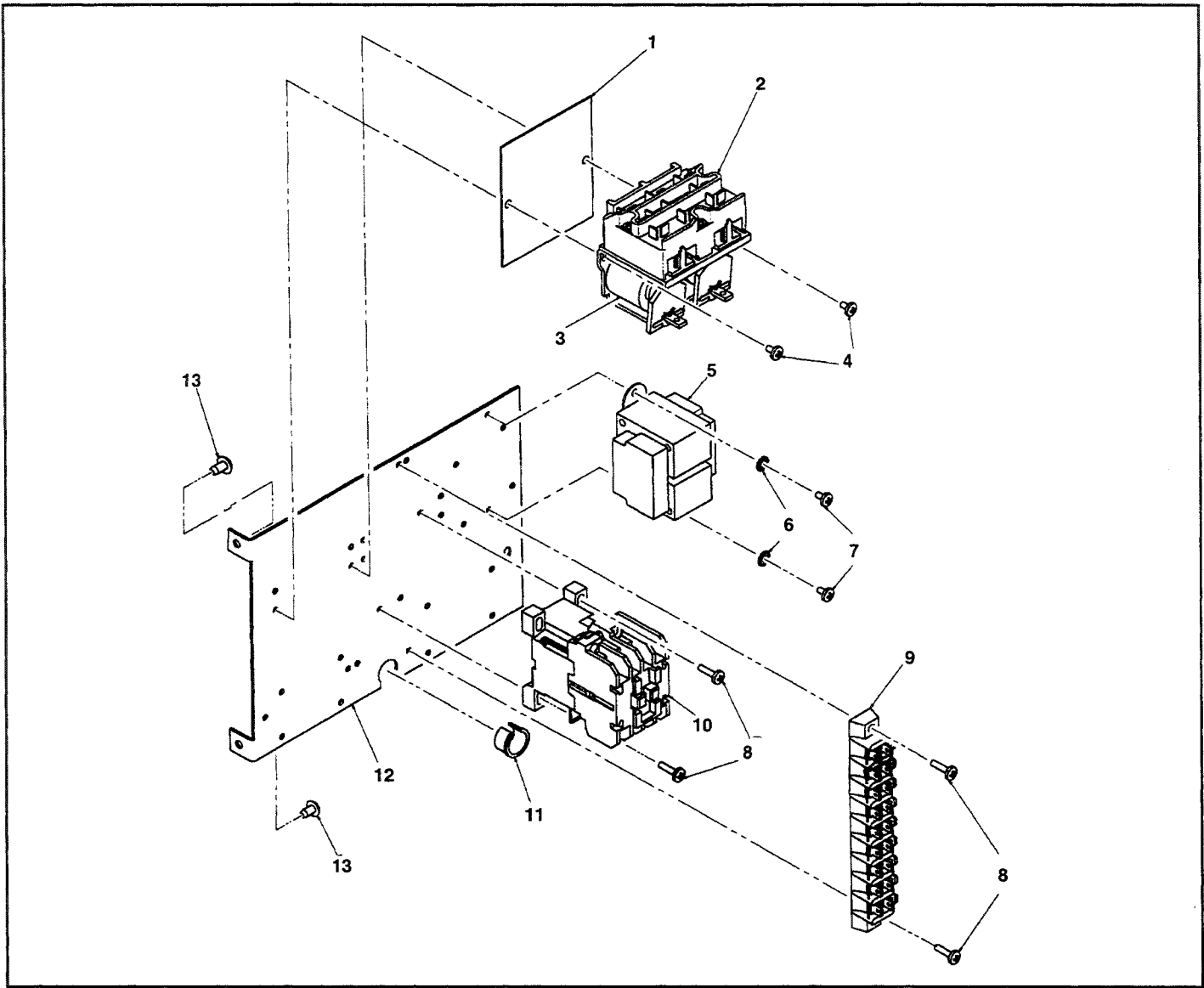
FIGURE 8-2B. HOIST MOTOR PARTS (1 PHASE)



Index No.	Part Name	Part No.
1	Insulator	JF-759-3
2	Reversing Contactor 24V. Coils	JF-829-1
	Reversing Contactor 115V. Coils	JF-829
3	Coil (24V.)	JF-37916-25
	Coil (115V.)	JF-37916-32
4	Screw	H-2742-P
5	Transformer:	
	Pri.: 115/230V., Sec.: 24V.	JL-821-212
	Pri.: 115/230V., Sec.: 115V.	JL-821-211
6	Lockwasher	H-4158
7	Screw	H-2751

Index No.	Part Name	Part No.
8	Screw	H-2752
9	Terminal Block	909K6
10	Capacitor, 216-259 mfd. (1 ¹³ / ₁₆ Dia.)	JL-810-3
	Capacitor, 400-480 mfd. (1 ¹³ / ₁₆ Dia.)	JL-810-4
11	SINPAC® Switch	839J2
12	Panel Plate	257J1B
13	Screw	H-2981-P
14	Cable Tie	H-9006
15	Bushing	H-7956

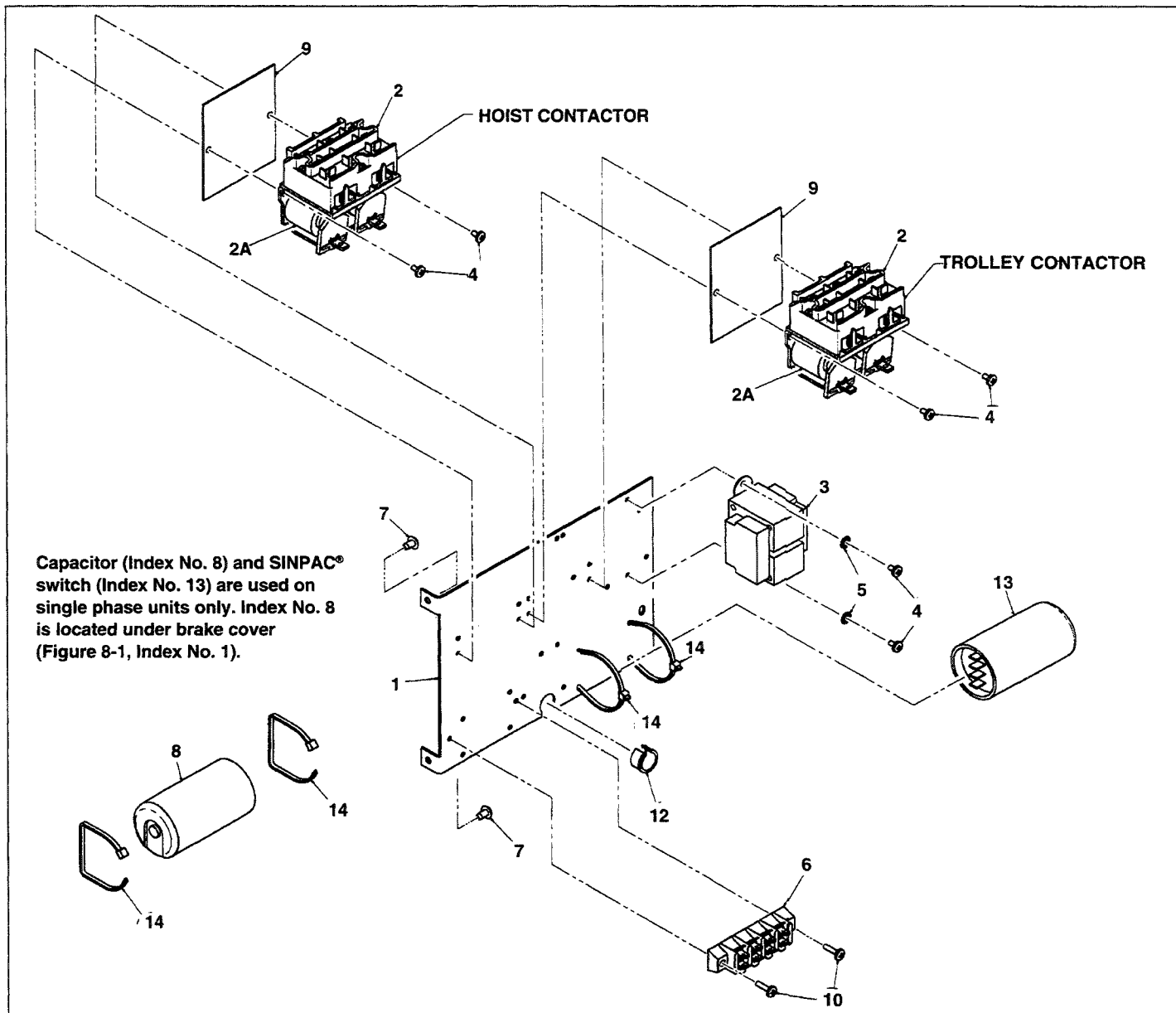
**FIGURE 8-3A. CONTROLLER AREA
SINGLE PHASE HOIST (ONLY)**



Index No.	Part Name	Part No.
1	Insulator	JF-759-3
2	Reversing Contactor 24V. Coils	JF-829-1
	Reversing Contactor 115V. Coils	JF-829
3	Coil (24V.)	JF-37916-25
	Coil (115V.)	JF-37916-32
4	Screw	H-2742-P
5	Transformer: (Single Speed)	
	Pri.: 208V, Sec.: 24V.	JL-821-272
	Pri.: 208V, Sec.: 115V.	JL-821-271
	Pri.: 230/460V, Sec.: 24V.	JL-821-232
	Pri.: 230/460V, Sec.: 115V.	JL-821-231
	Pri.: 575V, Sec.: 115V.	JL-821-252
	Pri.: 575V, Sec.: 115V.	JL-821-251
	Transformer: (Two Speed)	
	Pri.: 208V, Sec.: 24V.	JL-821-272
	Pri.: 208V, Sec.: 115V.	JL-821-271
	Pri.: 230V, Sec.: 24V.	JL-821-232
	Pri.: 230V, Sec.: 115V.	JL-821-231

Index No.	Part Name	Part No.
5	Transformer: (Two Speed)	
(cont.)	Pri.: 460V, Sec.: 24V.	JL-821-232
	Pri.: 460V, Sec.: 115V.	JL-821-231
	Pri.: 575V, Sec.: 115V.	JL-821-252
	Pri.: 575V, Sec.: 115V.	JL-821-251
6	Lockwasher	H-4158
7	Screw	H-2751
8	Screw	H-2752
9	Terminal Block	
	(Single Speed Only)	909K9
10	Two Speed Models Only	
	Speed Relay (24V. Coil)	820J3
	Speed Relay (115V. Coil)	820J4
11	Bushing	H-7956
12	Panel Plate	257J1B
13	Screw	H-2981-P

**FIGURE 8-3B. CONTROLLER AREA
THREE PHASE HOIST (ONLY)
SINGLE OR TWO SPEED MODELS**



Index No.	Part Name	Part No.
1	Panel Plate	257J1B
2	Reversing Contactor 24V. Coils	JF-829-1
	Reversing Contactor 115V. Coils	JF-829
2A	Coil (24V.)	JF-37916-25
	Coil (115V.)	JF-37916-32
3	Transformer:	
	Pri.: 115/230V, Sec.: 24V.	JL-821-212
	Pri.: 115/230V, Sec.: 115V.	JL-821-211
	Pri.: 208V, Sec.: 24V.	JL-821-272
	Pri.: 208V, Sec.: 115V.	JL-821-271
	Pri.: 230/460V, Sec.: 24V.	JL-821-232
	Pri.: 230/460V, Sec.: 115V.	JL-821-231
	Pri.: 575V, Sec.: 115V.	JL-821-252
	Pri.: 575V, Sec.: 115V.	JL-821-251

Index No.	Part Name	Part No.
4	Screw	H-2742-P
5	Lockwasher	H-4158
6	Single Phase Only Terminal Block	909K4
7	Screw	H-2981-P
8	Single Phase Only (1 ³ / ₁₆ " Dia.) Hoist Capacitor, 216-259 mfd. Hoist Capacitor, 400-480 mfd.	JL-810-3 JL-810-4
9	Insulator	JF-759-3
10	Screw	H-2752
11*	Splice Connector	H-5757
12	Bushing	H-7956
13	Single Phase Only Hoist SINPAC® Switch	839J2
14	Cable Tie	H-9006

Note: See Figure 8-12B for Trolley Capacitor & SINPAC® Switch.

**FIGURE 8-3C. CONTROLLER AREA
SINGLE SPEED HOIST WITH SINGLE SPEED TROLLEY
(SINGLE OR THREE PHASE)**

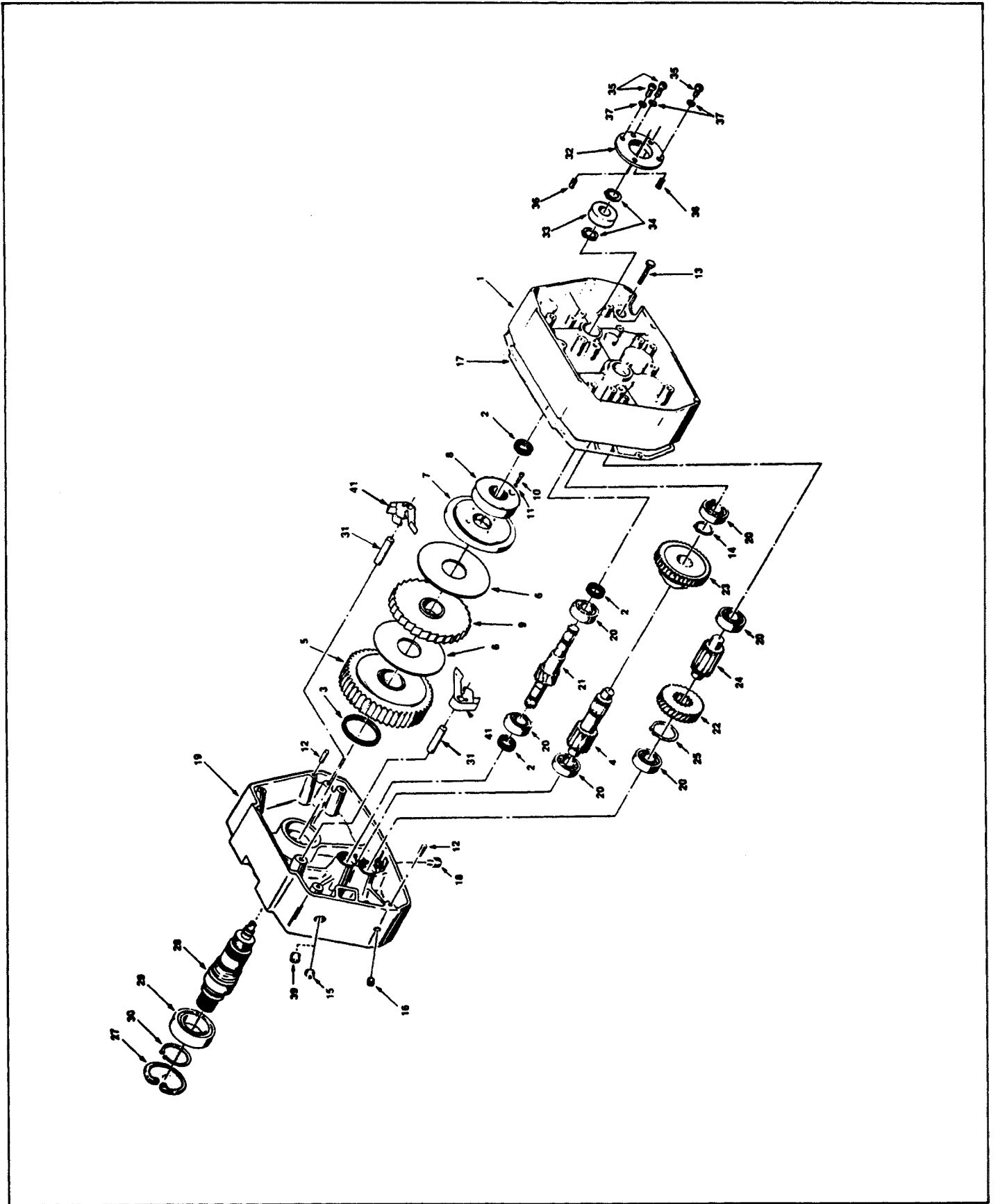


FIGURE 8-4. HOIST TRANSMISSION

Index No.	Part Name	Part No.
1	Transmission Cover	34J16
2	Seal	561K2
3	Seal	MA-562
4	Output Pinion	404J1
5	Output Gear Assembly	407JG26
6	Brake Disc	580J8
7	Pressure Plate	5J6
8	Nut	130J3
9	Ratchet and Bushing Assembly	7JG15-2
10	Screw	H-2255
11	Lock Washer	H-4133
12	Dowel Pin (Housing)	H-5382
13	Screw (Housing)	H-2978-P
14	Retaining Ring	H-5503
15	Fill Plug, Vented	H-6258
16	Level Plug	S-25-13
17	Gasket	560J5
18	Drain Plug	H-6268
19	Transmission Housing	35J6
20	Bearing	500K7
21	Input Pinion:	
	WR-1010	400J9
	WR-1016	400J1
	WR-1021	400J2
	WR-1032	400J3
	WR-2010	400J9
	WR-2016	400J1
22	Input Gear:	
	WR-1010	401J9
	WR-1016	401J5
	WR-1021	401J11
	WR-1032	401J3
	WR-2010	401J9
	WR-2016	401J5
23	Load Equalizer Assembly:	
	WR-1010	591JG20
	WR-1016	591JG4
	WR-1021	591JG5
	WR-1032	591JG5
	WR-2010	591JG6
	WR-2016	591JG7

Index No.	Part Name	Part No.
24	Intermediate Pinion:	
	WR-1010	402J1
	WR-1016	402J2
	WR-1021	402J3
	WR-1032	402J3
	WR-2010	402J1
	WR-2016	402J2
25	Retaining Ring:	
	WR-1010	H5553
	WR-1016	H5549
	WR-1021	H5530
	WR-1032	H5530
	WR-2010	H5553
	WR-2016	H5549
26*	Transmission Replacement Oil Kit	14J1
27	Retaining Ring	H-5566
28	Output Shaft	132J23
29	Bearing	500K29
30	Retaining Ring	H-5539
31	Dowel Pin (Pawl)	H-5493
32	Bearing Adapter	32J2
33	Bearing	500K3
34	Retaining Ring	H-5536
35	Screw	H-2694-P
36	Dowel Pin	H-5383
37	Washer	H-4082-P
38*	Seal Kit (Includes three 561K2 seals, one MA-562 seal and one 560J5 gasket)	14J2
39	Shipping Plug (Non-Vented)	S-25-4
41	Pawl Assembly	25JG4-2

*Not illustrated.

FIGURE 8-4. HOIST TRANSMISSION

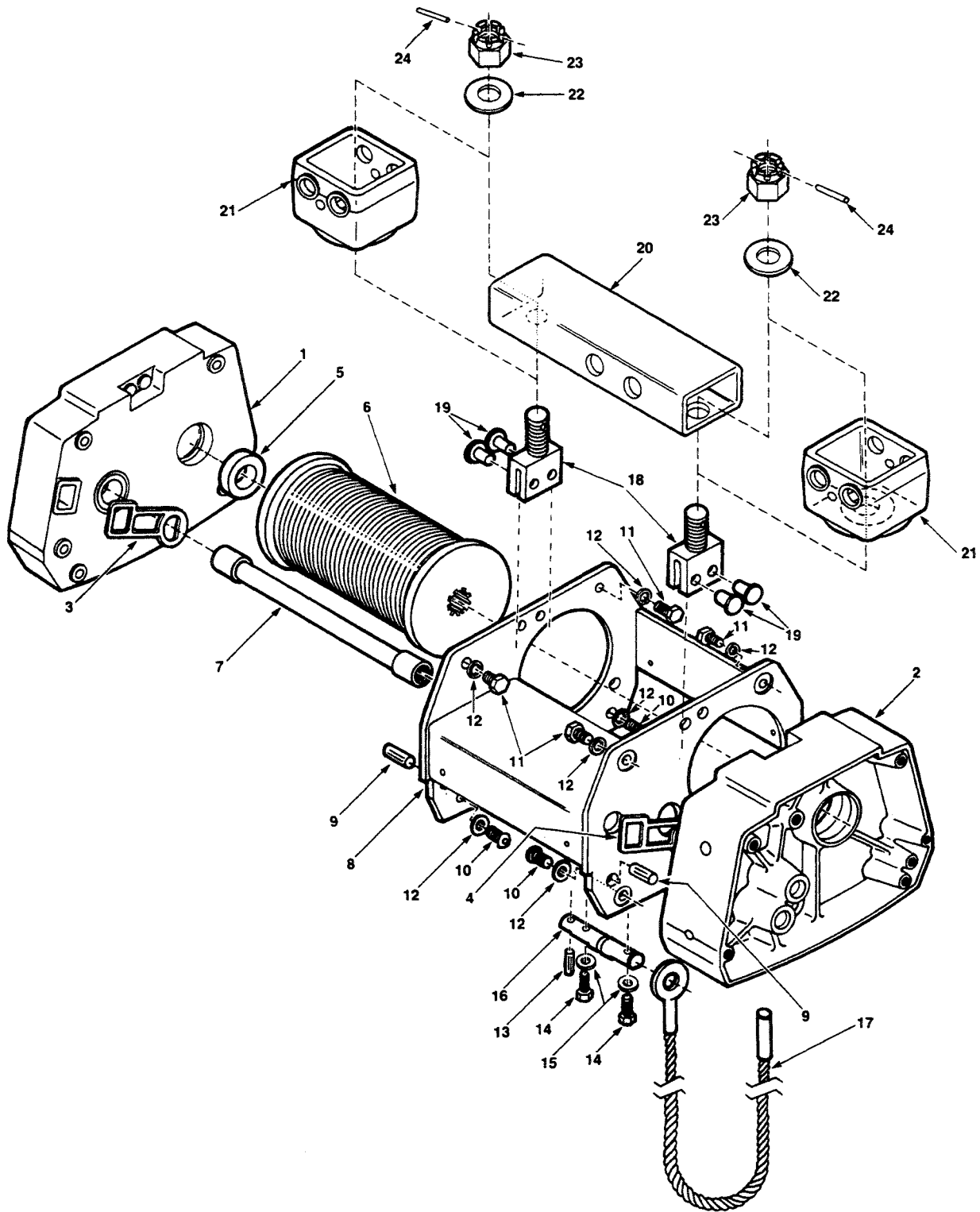
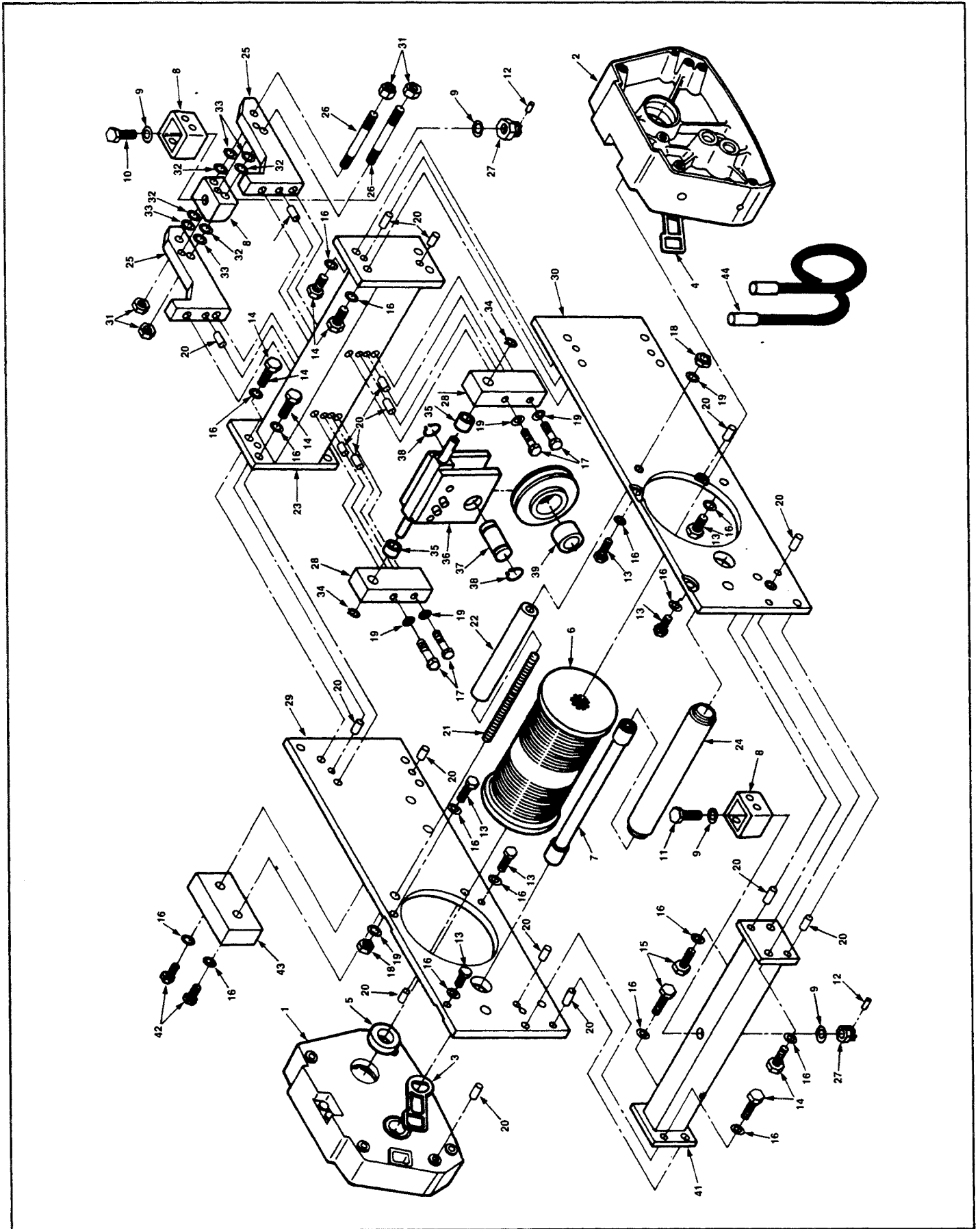


FIGURE 8-5A. DRUM AREA, STANDARD HEADROOM MODELS
2 PART SINGLE, PARALLEL MOUNT

Index No.	Part Name	Part No.
1	Motor Adapter:	
	1/2 HP	39J3-1
	1 HP	39J3
	3/4 HP Single Speed 3 Phase	39J3-1
	3/4 HP Two Speed 3 Phase	39J3
	3/4 HP Single Phase	39J3
2	Transmission Housing	35JG6
3	Gasket	560J12-1
4	Gasket	560J12-2
5	Bearing	500K5
6	Drum:	
	15 ft. Lift	16JG13-1
	25 ft. Lift	16JG13-2
	35 ft. Lift	16JG13-9
	50 ft. Lift	16JG13-6
	65 ft. Lift	16JG13-8
7	Motor Coupling:	
	15 ft. Lift	107JG7-1
	25 ft. Lift	107JG7-2
	35 ft. Lift	107JG7-9
	50 ft. Lift	107JG7-6
	65 ft. Lift	107JG7-8
8	Suspension Assembly:	
	15 ft. Lift	33JG14-1
	25 ft. Lift	33JG15-1
	35 ft. Lift	33JG26-4
	50 ft. Lift	33JG26-2
	65 ft. Lift	33JG26-3

Index No.	Part Name	Part No.
9	Driv-Lok Pin	H-5230-5
10	Screw, Button Head	H-2999-22
11	Screw, Hex Head	S44-21
12	Lock Washer	H-4066-P
13	Spring Pin	S-50-43
14	Screw, Hex Head	S-44-41
15	Lock Washer	H-4157
16	Anchor Pin	18J13
17	Wire Rope Assembly:	
	15 ft. Lift	19J101
	25 ft. Lift	19J102
	35 ft. Lift	19J110
	50 ft. Lift	19J107
	65 ft. Lift	19J109
18	Suspension Lug:	
	15 ft. Lift	50J31-1
	25, 35, 50 & 65 ft. Lift	50J48
19	Clevis Pin	103J10
20	Yoke	
	(Used on 15 ft. Lift Only)	190J11
21	Suspension Adaptor	
	(Used on 25, 35, 50 & 65 ft. Lift)	50J33
22	Washer	H-4012-P
23	Slotted Hex Nut	H-3928-P
24	Driv-Lok Pin	H-5190

**FIGURE 8-5A. DRUM AREA, STANDARD HEADROOM MODELS
2 PART SINGLE, PARALLEL MOUNT**

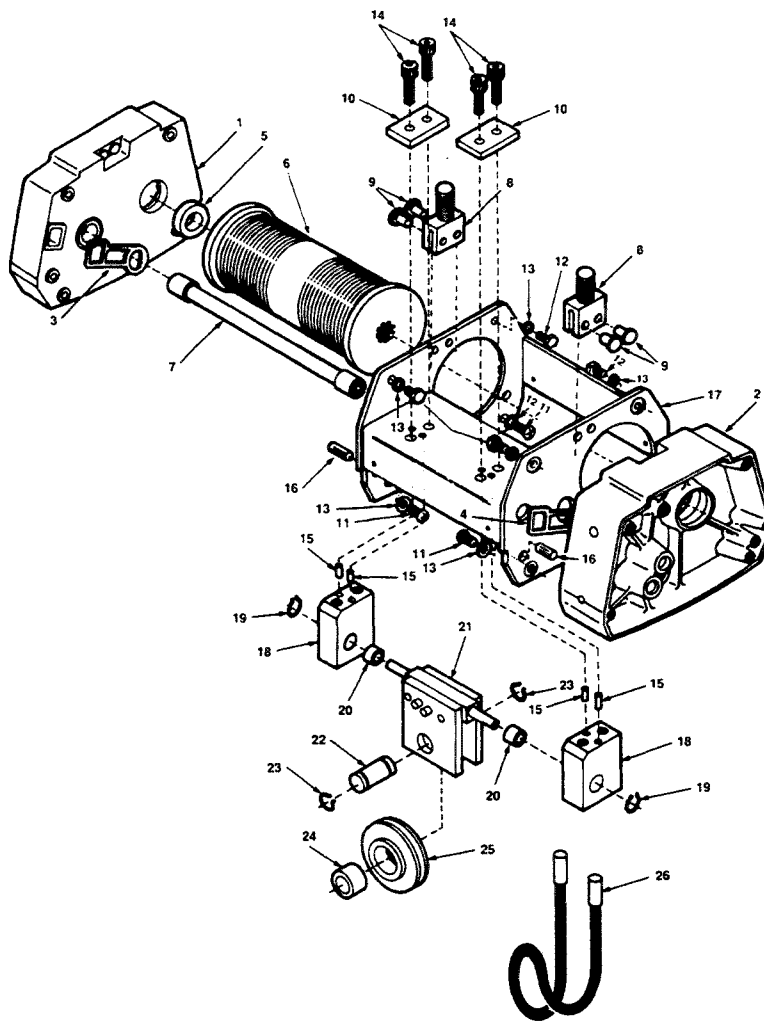


**FIGURE 8-5B. DRUM AREA, LOW HEADROOM MODELS
2 PART DOUBLE, CROSS MOUNT**

Index No.	Part Name	Part No.
1	Motor Adapter: 1/2 HP 1 HP 3/4 HP Single Speed 3 Phase 3/4 HP Two Speed 3 Phase 3/4 HP Single Phase	39J3-6 39J3-2 39J3-6 39J3-2 39J3-2
2	Transmission Housing	35JG6
3	Gasket	560J12-1
4	Gasket	560J12-2
5	Bearing	500K5
6	Drum Assembly: 15 ft. Lift 30 ft. Lift	16JG13-3 16JG13-7
7	Drive Coupling: 15 ft. Lift 30 ft. Lift	107JG7-3 107JG7-7
8	Suspension Adaptor	50J33
9	Washer	H-4012-P
10	King Bolt	7009J-2
11	King Bolt	700J9-1
12	Pin	H-5190
13	Screw	S-44-21
14	Screw	S-44-23
15	Screw	S-44-68
16	Washer	H-4066P
17	Bolt	H-2356
18	Nut	S12-27
19	Washer	H-4083P
20	Pin	H-5230-5
21	Tie Rod: 15 ft. Lift 30 ft. Lift	931J1-3 931J1-4
22	Tie Rod Spacer: 15 ft. Lift 30 ft. Lift	200J28-3 200J28-4

Index No.	Part Name	Part No.
23	Tube Assembly: 15 ft. Lift 30 ft. Lift	200JG33-1A 200JG33-2A
24	Coupling Guard: 15 ft. Lift 30 ft. Lift	200J31-1 200J31-2
25	Suspension Plate	296J8
26	Load Pin	103K14
27	Nut	H-3928P
28	Pillow Block	503J6
29	Side Frame	48J8
30	Side Frame	48J9
31	Nut	H-3945
32	Washer (.075 Thick)	H-4210
33	Washer (.135 Thick)	H-4209
34	Retaining Ring	H-5526
35	Bushing	SK-6415-96W
36	Equalizer Sheave Assembly (Includes Index No. 37-40)	113JG2
37	Sheave Pin	122J20
38	Retaining Ring	H-5527
39	Bushing	MA-532
40	Sheave	28J16
41	Tube Assembly: 15 ft. Lift 30 ft. Lift	200JG32-1A 200JG32-2A
42	Screw	S-44-169
43	Counterweight	52J6
44	Wire Rope Assembly: 15 ft. Lift 30 ft. Lift	19J303 19J305

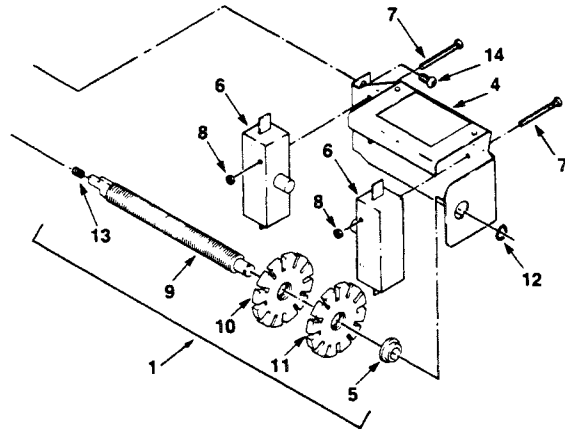
**FIGURE 8-5B. DRUM AREA, LOW HEADROOM MODELS
2 PART DOUBLE, CROSS MOUNT**



Index No.	Part Name	Part No.
1	Motor Adaptor: 1/2 HP Single Speed 3 Phase 1 HP Single Speed 3 Phase 3/4 Single Speed 3 Phase 3/4 Two Speed 3 Phase 3/4 HP Single Phase	39J3-1 39J3 39J3-1 39J3 39J3
2	Transmission Housing	35JG6
3	Gasket	560J12-1
4	Gasket	560J12-2
5	Bearing	500K5
6	Drum Assembly: 15 ft. Lift 30 ft. Lift	16JG13-3 16JG13-7
7	Drive Coupling: 15 ft. Lift 30 ft. Lift	107JG7-3 107JG7-7
8	Suspension Lug	50J48
9	Clevis Pin	103J10
10	Support Plate	296J9
11	Screw	H2999-22

Index No.	Part Name	Part No.
12	Screw	S-44-21
13	Lock Washer	H-4066-P
14	Screw	S-49-19
15	Pin	H-5210
16	Pin	H-5230-5
17	Suspension Assembly: 15 ft. Lift 30 ft. Lift	33JG25-1 33JG25-2
18	Pillow Block	503J8
19	Retaining Ring	H-5526
20	Bushing	SK-6415-96
21	Equalizer Sheave Assembly (Includes Index No. 22-25)	113JG2
22	Sheave Pin	122J20
23	Retaining Ring	H-5527
24	Bushing	MA-532
25	Sheave	28J16
26	Wire Rope Assembly: 15 ft. Lift 30 ft. Lift	19J303 19J305

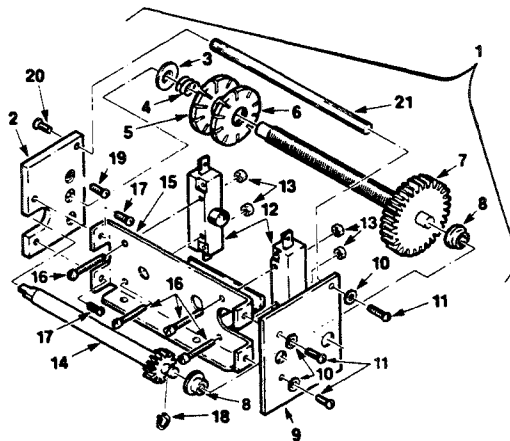
**FIGURE 8-5C. DRUM AREA, TRUE VERTICAL LIFT MODELS
2 PART DOUBLE, PARALLEL MOUNT**



Index No.	Part Name	Part No.
1	Limit Switch & Shaft Assembly (Consists of Index Nos. 4 thru 12)	918JG7
4	Limit Switch Bracket Assembly (Includes Index No. 5)	JF-900-3
5	Limit Switch Bushing	JF-531-4
6	Microswitch, Limit	815J1
7	Screw	H-1402-P

Index No.	Part Name	Part No.
8	Nut	H-3944
9	Limit Switch Shaft	JF-117-3
10	Limit Switch Nut (Brass)	SK6000-63W
11	Limit Switch Nut (Zinc)	SK6000-63Z
12	Retaining Ring	H-5520
13	Spring	JF-343-3
14	Screw	H-2694-P

FIGURE 8-6A. LIMIT SWITCH PARTS (All Lifts Except 65 Ft.)



Index No.	Part Name	Part No.
1	Long Lift Limit Switch Assembly (all items except No.19)	944JG6WR
2	Mounting Plate	129J1
3	Thrust Washer	255K16
4	Spring	PB-287
5	Zinc Nut	SK6000-63Z
6	Brass Nut	SK6000-63W
7	Shaft and Gear Assembly	117JG2
8	Bushing	JF-531-4
9	End Plate	258J8
10	Lock Washer	H-4158

Index No.	Part Name	Part No.
11	Screw	H-2741-P
12	Switch	815J1
13	Locknut	H-3944
14	Drive Pinion	427J1
15	Frame and Guide Assembly	258JG7
16	Screw	H-1402-P
17	Screw	854823
18	Retaining Ring	H-5520
19	Mounting Screw	H-2981-P
20	Flat Head Screw	H-1210
21	Post	110J14

**FIGURE 8-6B. LONG LIFT LIMIT SWITCH PARTS
(Used on 65 Ft. Lift Only)**

Index No.	Part Name	Part No.
1	Disc Brake Assembly:	
	WR-1010 & WR-1016:	
	Single Speed	
	115-230V	854JG6
	230/460V	854JG7
	575V	854JG9
	208V	854JG10
	Two Speed	
	230V	
	460V	854JG7
	575V	854JG8
	208V	854JG9
	WR-1021, WR-1032, WR-2010, WR-2016:	854JG10
	Single Speed	
	115/230V	854JG1
	230/460V	854JG2
	575V	854JG4
	208V	854JG5
	Two Speed	
	230V	854JG2
460V	854JG3	
575V	854JG4	
208V	854JG5	
2	Plate & Frame Assembly	857JG1

Index No.	Part Name	Part No.
3	Plate & Armature Assembly	858JG1
4	Plate & Stud Assembly	859JG1
5	Brake Plate	291J1
6	Spring	344J6
7	Brake Disc	581J1A
8	Retainer	JF-710
9	Locking Nut	H-3978
10	Coil:	
	115V (For Brake 854JG6, 854JG1)	JF-853-1
	230V (For Brake 854JG7, 854JG2)	JF-853-2
	460V (For Brake 854JG8, 854JG3)	JF-853-3
	575V (For Brake 854JG9, 854JG4)	JF-853-4
	208V (For Brake 854JG10, 854JG5)	JF-853-5
11	Spacer (1/2 HP Models Only)	141J2
12	Screw	H-2976-P
13	Brake Adapter	142J1
14	Retaining Ring	H-5501
15	Transmission Cover (Reference — Figure 8-1)	34J16
16**	Shading Coil Element	860J1
17*	Adhesive (1 oz. Tube)	H-7812
18	Decal, Load Equalizer	676J1
19	Lock Washer	H-4134
20	Bearing Adapter (Reference — See Figure 8-4)	32J2

* Not illustrated.

** Replacement requires use of adhesive.

FIGURE 8-7. MOTOR BRAKE PARTS

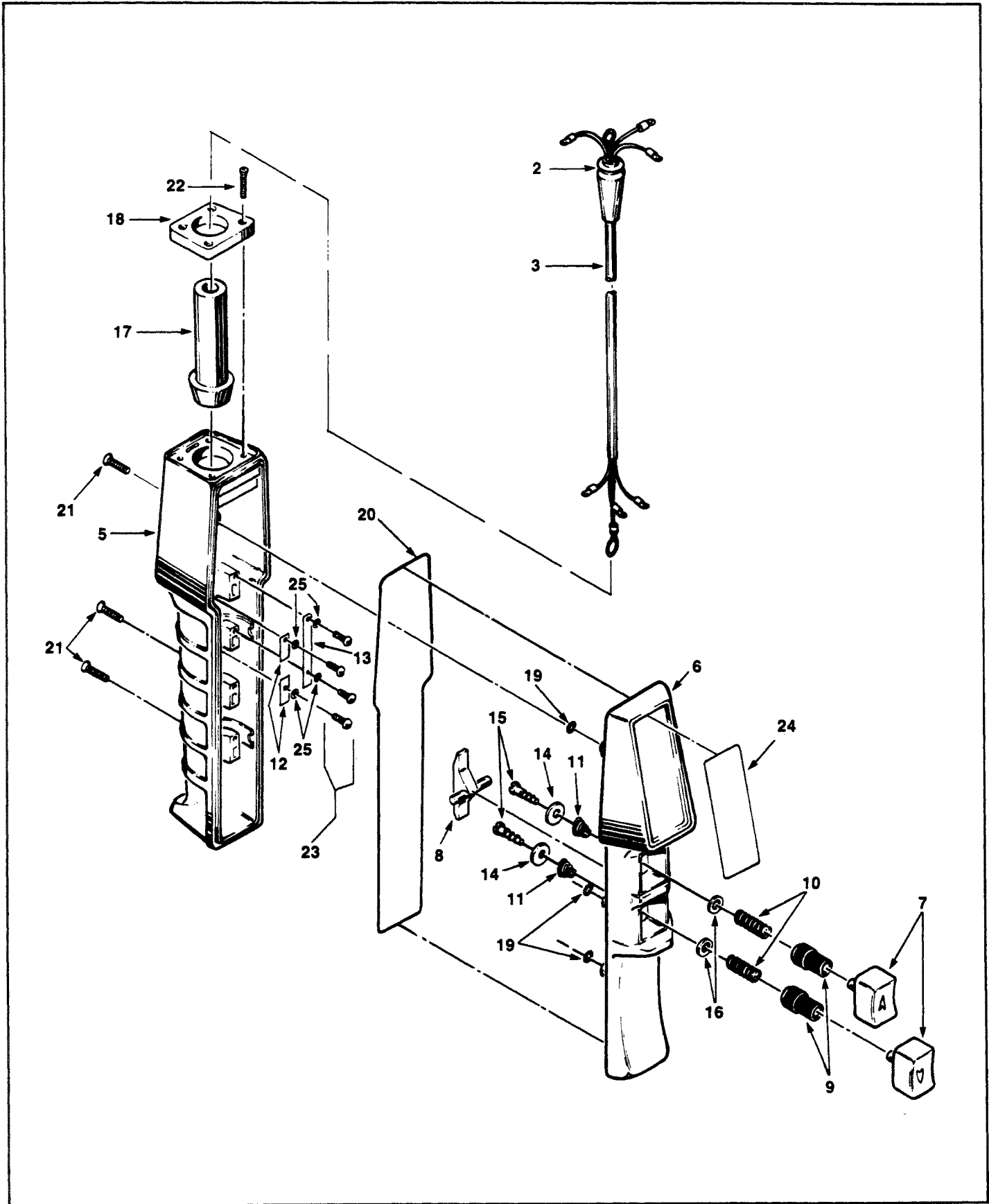


FIGURE 8-8A. PUSHBUTTON (SINGLE SPEED HOISTS)

Index No.	Part Name	Part No.
1	Pushbutton and Cable Assembly: (Consists of Index Nos. 2 thru 25) PB Drop Length: 11 Ft. 21 Ft. 26 Ft. 31 Ft. 46 Ft. 61 Ft. Special PB Drop Length	PB-299-11B PB-299-21B PBS-299-26B PB-299-31B PBS-299-46B PBS-299-61B PBS-299-*B
2	Rubber Grommet	JF-761
3	Pushbutton Cable Assembly: PB Drop Length: 11 Ft. 21 Ft. 26 Ft. 31 Ft. 46 Ft. 61 Ft. Special PB Drop Length	PB-299-11 PB-299-21 PBS-299-26 PB-299-31 PBS-299-46 PBS-299-61 PBS-299-*
4	Pushbutton Assembly: (Consist of Index Nos. 5 thru 25)	534K97-B
5	Enclosure	PB-282-4
6	Cover	PB-298
7	Pushbutton	PB-284-2
8	Interlock	PB-285
9	Boot	PB-286
10	Spring, Compression	PB-287
11	Spring, Conical	PB-288
12	Contact Plate	PB-289
13	Contact Plate, Common	PB-290
14	Washer, Contact	PB-291
15	Screw	PB-301
16	Washer, Boot	PB-293
17	Grommet	PB-294-1
18	Cap, Enclosure	PB-295
19	"O" Ring	X-6477-1
20	Rubber Seal	H-7851
21	Screw	H-2991
22	Screw	H-2992
23	Screw	H-2993
24	Warning Tab	PB-296
25	Lock Washer	H-4160

(* Equal To P.B. Drop)

**FIGURE 8-8A. PUSHBUTTON
(SINGLE SPEED HOISTS)**

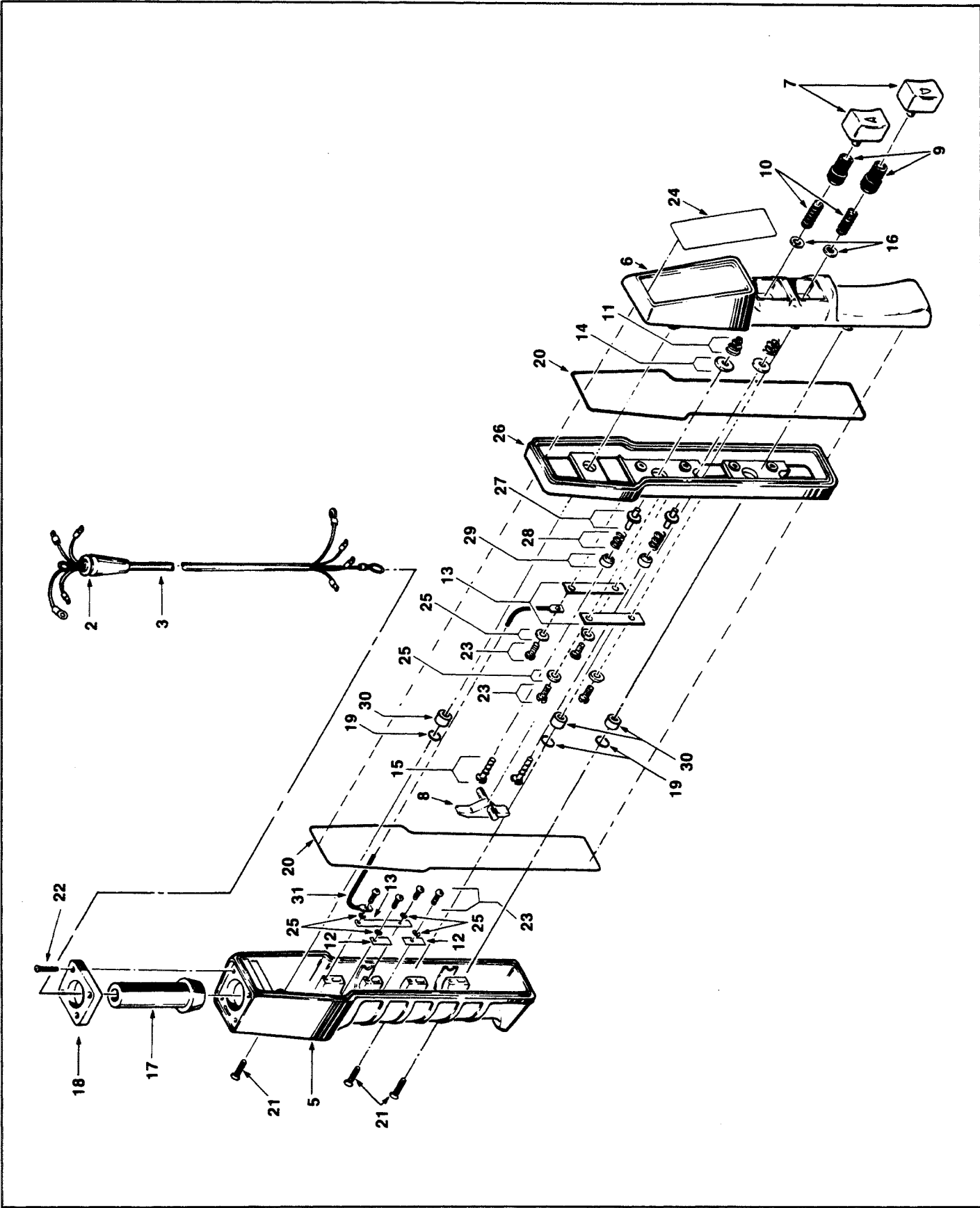


FIGURE 8-8B. PUSHBUTTON (TWO SPEED HOISTS)

Index No.	Part Name	Part No.
1	Pushbutton and Cable Assembly: (Consists of Index Nos. 2 thru 31) PB Drop In Feet:	
	11 Ft.	534JG4-11
	21 Ft.	534JG4-21
	26 Ft.	534JG4-26
	31 Ft.	534JG4-31
	46 Ft.	534JG4-46
	61 Ft.	534JG4-61
	Special PB Drop	534JG4-*
2	Rubber Grommet	JF-761
3	Pushbutton Cable Assembly: PB Drop In Feet:	
	11 Ft.	PB-300-11
	21 Ft.	PB-300-21
	26 Ft.	PBS-300-26
	31 Ft.	PB-300-31
	46 Ft.	PBS-300-46
	61 Ft.	PBS-300-61
	Special PB Drop	PBS-300-*
4	Pushbutton Assembly: (Consist of Index Nos. 5 thru 31)	534JG4
5	Enclosure	PB-282-4
6	Cover	PB-298
7	Pushbutton	PB-284-22
8	Interlock	PB-285-1
9	Boot	PB-286
10	Spring, Compression	PB-287
11	Spring, Conical	PB-288
12	Contact Plate	PB-289
13	Contact Plate, Common	PB-290
14	Washer, Contact	PB-291
15	Screw	H-1852-P
16	Washer, Boot	PB-293
17	Grommet	PB-294-1
18	Cap, Enclosure	PB-295
19	"O" Ring	X-6477-1
20	Rubber Seal	H-7851
21	Screw (Enclosure)	H-2925
22	Screw (Cap)	H-2992
23	Screw (Plates)	H-2993
24	Warning Tab	PB-296
25	Lock Washer	H-4160
26	2-Speed Adapter	PB-308
27	Insulating Bushing	755J1
28	Spring, Lower	344J5
29	Contact Button	201J1
30	Bushing	200J16
31	Jumper Wire	JF-940-42

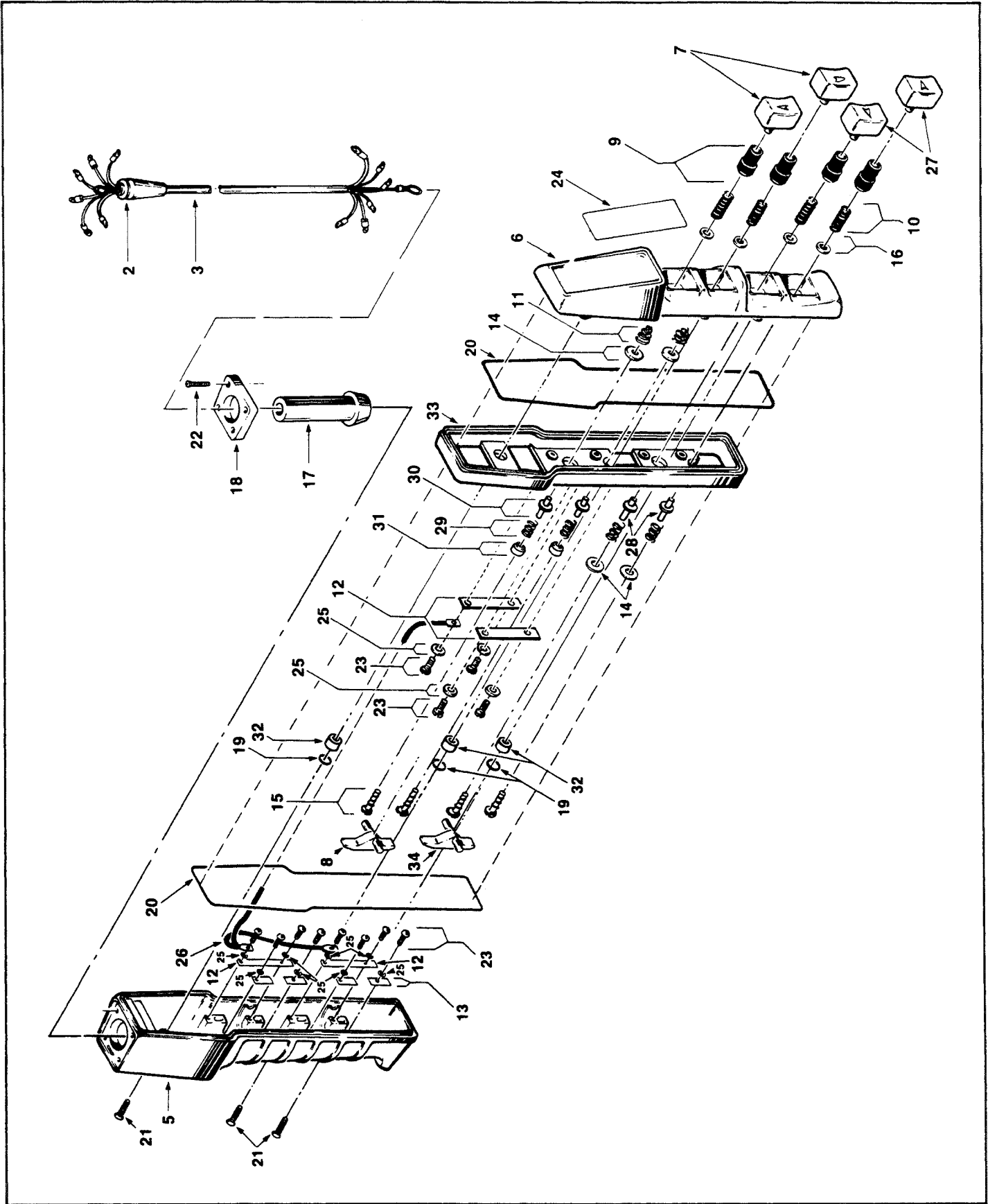
(* Equal To P.B. Drop)

**FIGURE 8-8B. PUSHBUTTON
(TWO SPEED HOISTS)**

Index No.	Part Name	Part No.
1	Pushbutton and Cable Assembly: (Consists of Index Nos. 2 thru 27) PB Drop In Feet:	
	11 Ft.	PB-300-11A
	21 Ft.	PB-300-21A
	26 Ft.	PBS-300-26A
	31 Ft.	PB-300-31A
	46 Ft.	PBS-300-46A
	61 Ft.	PBS-300-61A
	Special PB Drop	PBS-300-*A
2	Rubber Grommet	JF-761
3	Pushbutton Cable Assembly: PB Drop In Feet:	
	11 Ft.	PB-300-11
	21 Ft.	PB-300-21
	26 Ft.	PBS-300-26
	31 Ft.	PB-300-31
	46 Ft.	PBS-300-46
	61 Ft.	PBS-300-61
	Special PB Drop	PBS-300-*
4	Pushbutton Assembly: (Consist of Index Nos. 5 thru 27)	534K98
5	Enclosure	PB-282-4
6	Cover	PB-283
7	Pushbutton (Hoist)	PB-284-2
8	Interlock	PB-285
9	Boot	PB-286
10	Spring, Compression	PB-287
11	Spring, Conical	PB-288
12	Contact Plate, Common	PB-290
13	Contact Plate	PB-289
14	Washer, Contact	PB-291
15	Screw	PB-301
16	Washer, Boot	PB-293
17	Grommet	PB-294-2
18	Cap, Enclosure	PB-295
19	"O" Ring	X-6477-1
20	Seal	H-7851
21	Screw	H-2991
22	Screw	H-2992
23	Screw	H-2993
24	Warning Tab	PB-296
25	Lock Washer	H-4160
26	Jumper (Common)	JF-940-42
27	Pushbutton (Trolley)	PB-284-1

(* Equal To P.B. Drop)

**FIGURE 8-8C. PUSHBUTTON
(SINGLE SPEED HOIST - SINGLE SPEED TROLLEY)**

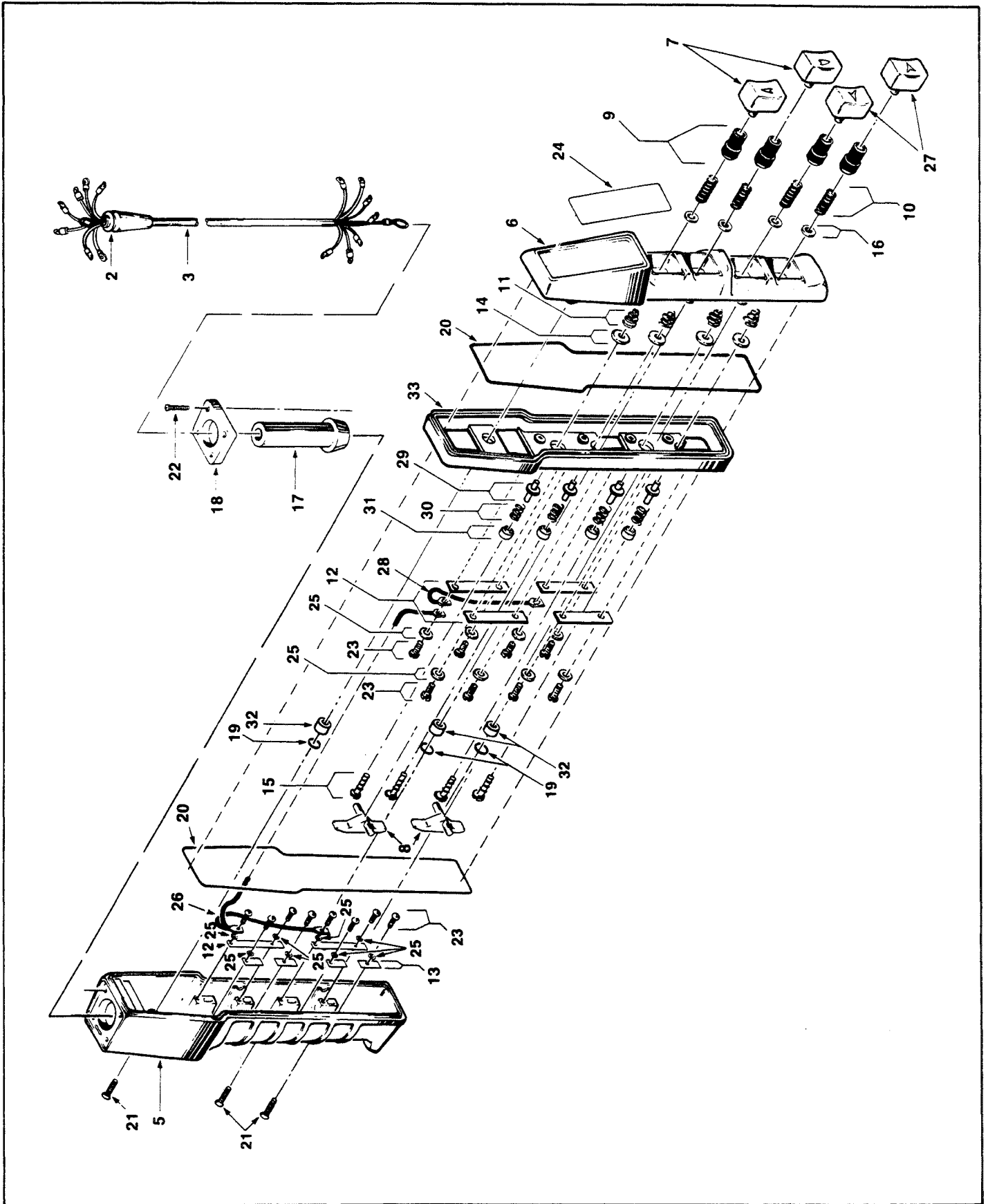


**FIGURE 8-8D. PUSHBUTTON
 (TWO SPEED HOIST, SINGLE SPEED TROLLEY;
 SINGLE SPEED HOIST, TWO SPEED TROLLEY)**

Index No.	Part Name	Part No.	Index No.	Part Name	Part No.
1	Pushbutton and Cable Assembly: (Consists of Index Nos. 2 thru 34)		4	Pushbutton Assembly: (Consist of Index Nos. 5 thru 34)	
	Two Speed Hoist, Single Speed Trolley			Two Speed Hoist, Single Speed Trolley	534JG5
	PB Drop In Feet:			Single Speed Hoist, Two Speed Trolley	534JG6
	11 Ft.	534JG5-11	5	Enclosure	PB-282-4
	21 Ft.	534JG5-21	6	Cover	PB-283
	26 Ft.	534JG5-26	7	Pushbutton (Hoist)	PB-284-22
	31 Ft.	534JG5-31	8	Interlock (Black)	PB-285-1
	46 Ft.	534JG5-46	9	Boot	PB-286
	61 Ft.	534JG5-61	10	Spring, Compression	PB-287
	Special PB Drop	534JG5-*	11	Spring, Conical	PB-288
	Single Speed Hoist, Two Speed Trolley		12	Contact Plate, Common	PB-290
	PB Drop In Feet:		13	Contact Plate	PB-289
	11 Ft.	534JG6-11	14	Washer, Contact	PB-291
	21 Ft.	534JG6-21	15	Screw	H-1852-P
	26 Ft.	534JG6-26	16	Washer, Boot	PB-293
	31 Ft.	534JG6-31	17	Grommet	PB-294-2
	46 Ft.	534JG6-46	18	Cap, Enclosure	PB-295
	61 Ft.	534JG6-61	19	"O" Ring	X-6477-1
	Special PB Drop	534JG6-*	20	Seal	H-7851
2	Rubber Grommet	JF-761-1	21	Screw	H-2925
3	Pushbutton Cable Assembly:		22	Screw	H-2992
	PB Drop In Feet:		23	Screw	H-2993
	11 Ft.	PB-309-11	24	Warning Tab	PB-296
	21 Ft.	PBS-309-21	25	Lock Washer	H-4160
	26 Ft.	PBS-309-26	26	Jumper	940J111
	31 Ft.	PB-309-31	27	Pushbutton (Trolley)	PB-284-21
	46 Ft.	PBS-309-46	28	Spacer	755J2
	61 Ft.	PBS-309-61	29	Spring, Lower	344J5
	Special PB Drop	PBS-309-*	30	Insulating Bushing	755J1
			31	Lower Contact	201J1
			32	Bushing	200J16
			33	Two-Speed Adapter	PB-308
			34	Interlock (Red)	PB-285

(* Equal To P.B. Drop)

**FIGURE 8-8D. PUSHBUTTON
(TWO SPEED HOIST, SINGLE SPEED TROLLEY;
SINGLE SPEED HOIST, TWO SPEED TROLLEY)**

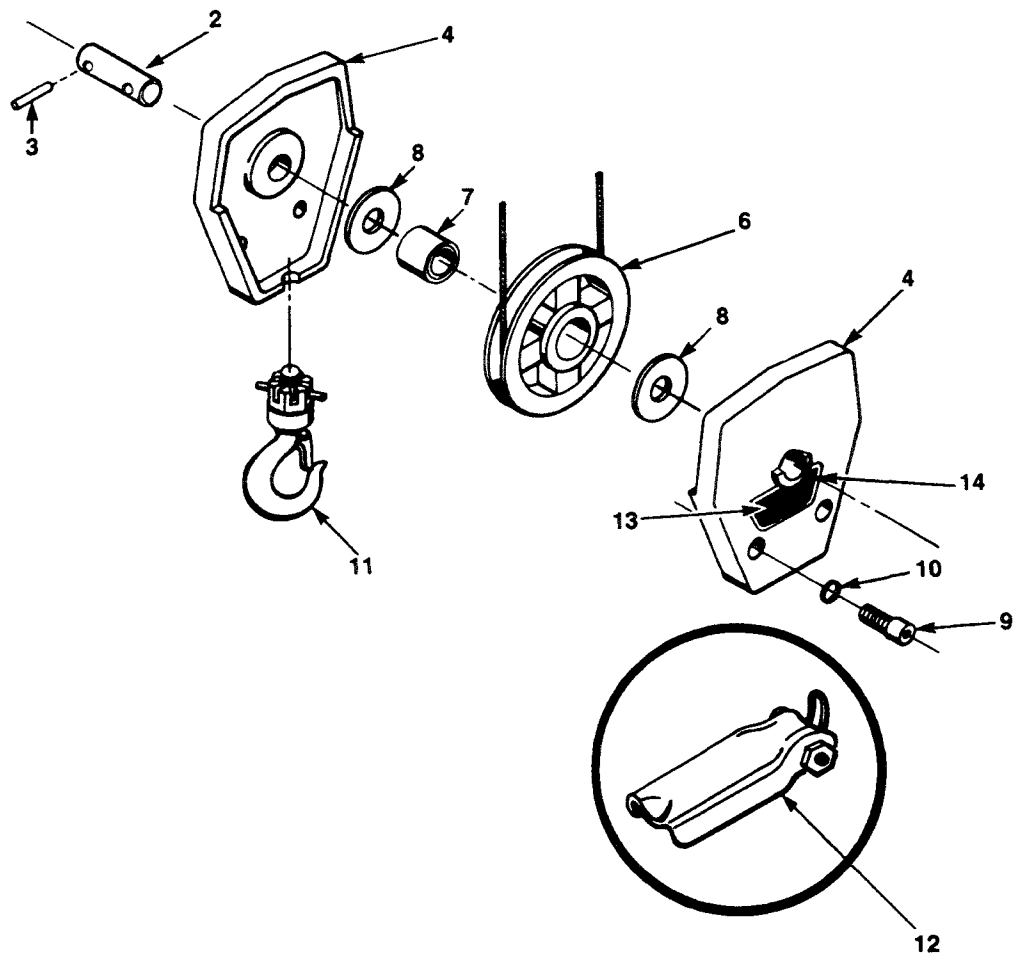


**FIGURE 8-8E. PUSHBUTTON
(TWO SPEED HOIST, TWO SPEED TROLLEY)**

Index No.	Part Name	Part No.	Index No.	Part Name	Part No.
1	Pushbutton and Cable Assembly: (Consists of Index Nos. 2 thru 33)		7	Pushbutton (Hoist)	PB-284-22
	PB Drop In Feet:		8	Interlock (Black)	PB-285-1
	11 Ft.	534JG7-11	9	Boot	PB-286
	21 Ft.	534JG7-21	10	Spring, Compression	PB-287
	26 Ft.	534JG7-26	11	Spring, Conical	PB-288
	31 Ft.	534JG7-31	12	Contact Plate, Common	PB-290
	46 Ft.	534JG7-46	13	Contact Plate	PB-289
	61 Ft.	534JG7-61	14	Washer, Contact	PB-291
	Special PB Drop	534JG7-*	15	Screw	H-1852-P
2	Rubber Grommet	JF-761-1	16	Washer, Boot	PB-293
3	Pushbutton Cable Assembly:		17	Grommet	PB-294-2
	PB Drop In Feet:		18	Cap, Enclosure	PB-295
	11 Ft.	PB-309-11	19	"O" Ring	X-6477-1
	21 Ft.	PB-309-21	20	Seal	H-7851
	26 Ft.	PBS-309-26	21	Screw	H-2925
	31 Ft.	PBS-309-31	22	Screw	H-2992
	46 Ft.	PBS-309-46	23	Screw	H-2993
	61 Ft.	PBS-309-61	24	Warning Tab	PB-296
	Special PB Drop	PBS-309-*	25	Lock Washer	H-4160
4	Pushbutton Assembly: (Consist of Index Nos. 5 thru 33)	534JG7	26	Jumper	940J111
5	Enclosure	PB-282-4	27	Pushbutton (Trolley)	PB-284-21
6	Cover	PB-283	28	Jumper (Two-Speed Common)	JF-940-42
			29	Insulating Bushing	755J1
			30	Spring, Lower	344J5
			31	Lower Contact	201J1
			32	Bushing	200J16
			33	Two-Speed Adapter	PB-308

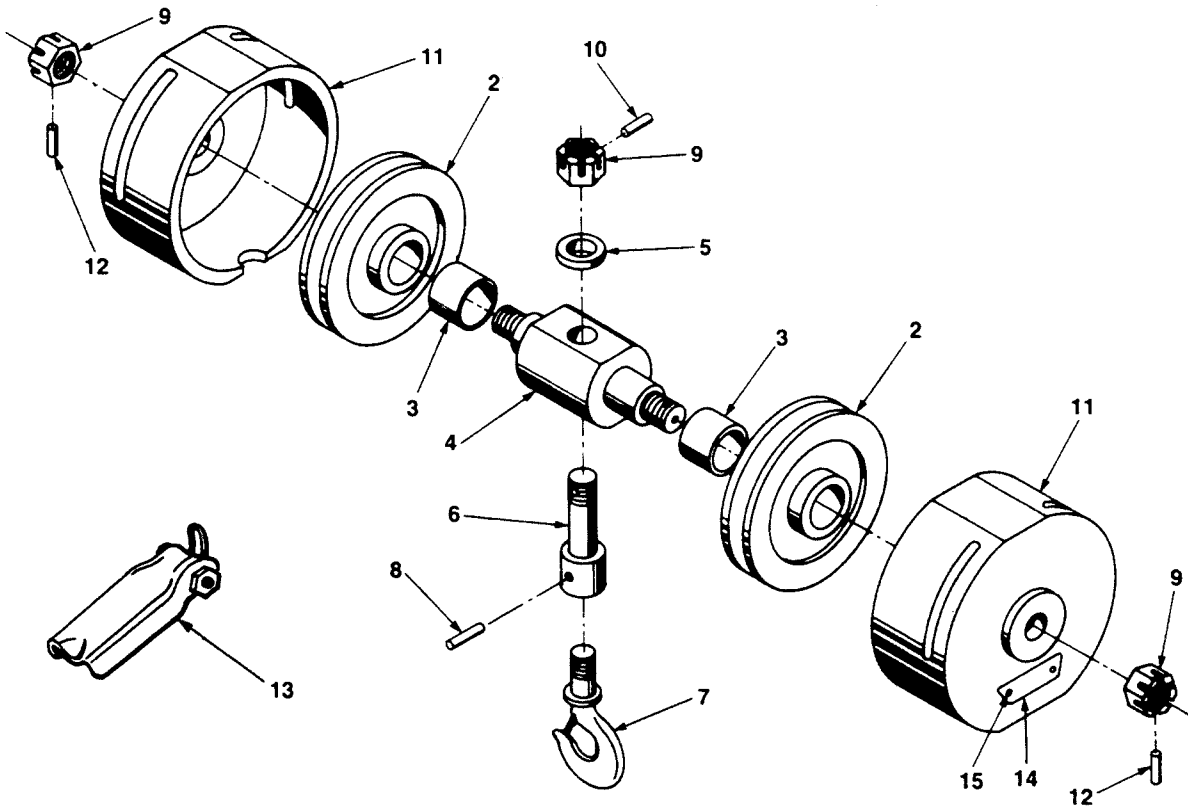
(* Equal To P.B. Drop)

**FIGURE 8-8E. PUSHBUTTON
(TWO SPEED HOIST, TWO SPEED TROLLEY)**



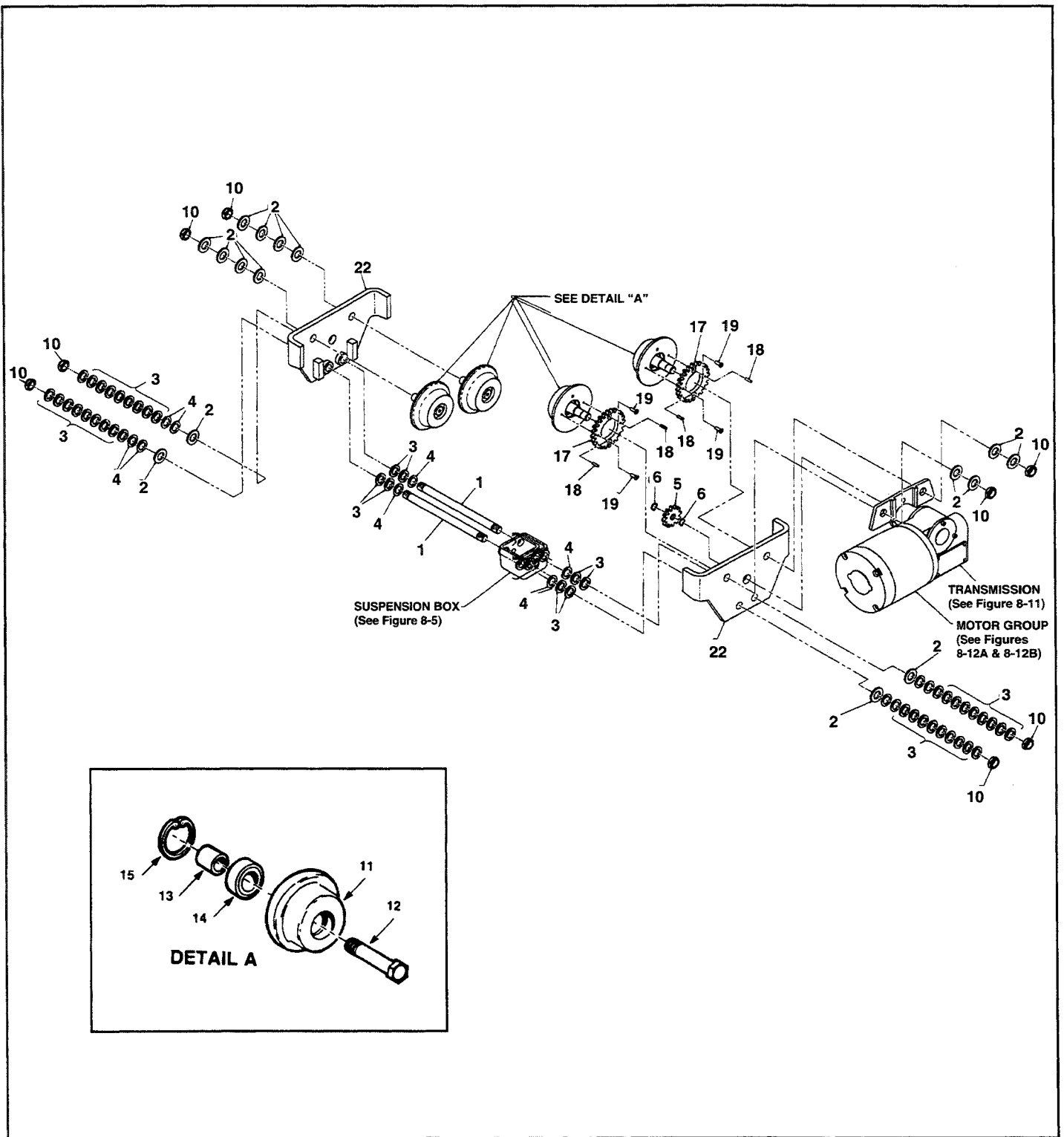
Index No.	Part Name	Part No.
1	Bottom Block Assembly, Complete (Consists of Index Nos. 2 thru 11)	30KG28
2	Bottom Block Shaft	100K2
3	Spring Pin	H-5235
4	Side Frame	30K1
5	Sheave Assembly (Includes Bearing)	28KG1
6	Sheave	28K1
7	Bearing	521K1
8	Thrust Washer	CB-255
9	Allen head Screw	S-49-19
10	Lock Washer	H-4139
11	Hook Assembly with Latch	3JG20S
12	Latch Kit	H-7540
13	Capacity Plate: 1/2 Ton	675K26
	1 Ton	675K28
14	Drive Rivet	H-2861-P

FIGURE 8-9A. BOTTOM BLOCK, STANDARD HEADROOM MODELS



Index No.	Part Name	Part No.
1	Bottom Block Assembly, Complete (Consists of Index No. 2 thru 12)	914JG27
2	Sheave	28K1
3	Bushing	530K14
4	Yoke	122J19
5	Bearing	JF-510
6	Shank Extension	124J11
7	Hook & Latch Assembly	3J20S
8	Driv-Lok Pin ($\frac{3}{16} \times 1\frac{1}{4}$)	H-5219
9	Slotted Nut	H-3986-P
10	Driv-Lok Pin ($\frac{3}{16} \times \frac{7}{8}$)	H-5159
11	Cover	30J24
12	Spring Pin	H-5260
13	Latch Kit	H-7540
14	Capacity Plate:	
	$\frac{1}{2}$ Ton	675K26
	1 Ton	675K28
15	Drive Rivet	H-2861-P

FIGURE 8-9B. BOTTOM BLOCK, LOW HEADROOM & TRUE VERTICAL LIFT MODELS

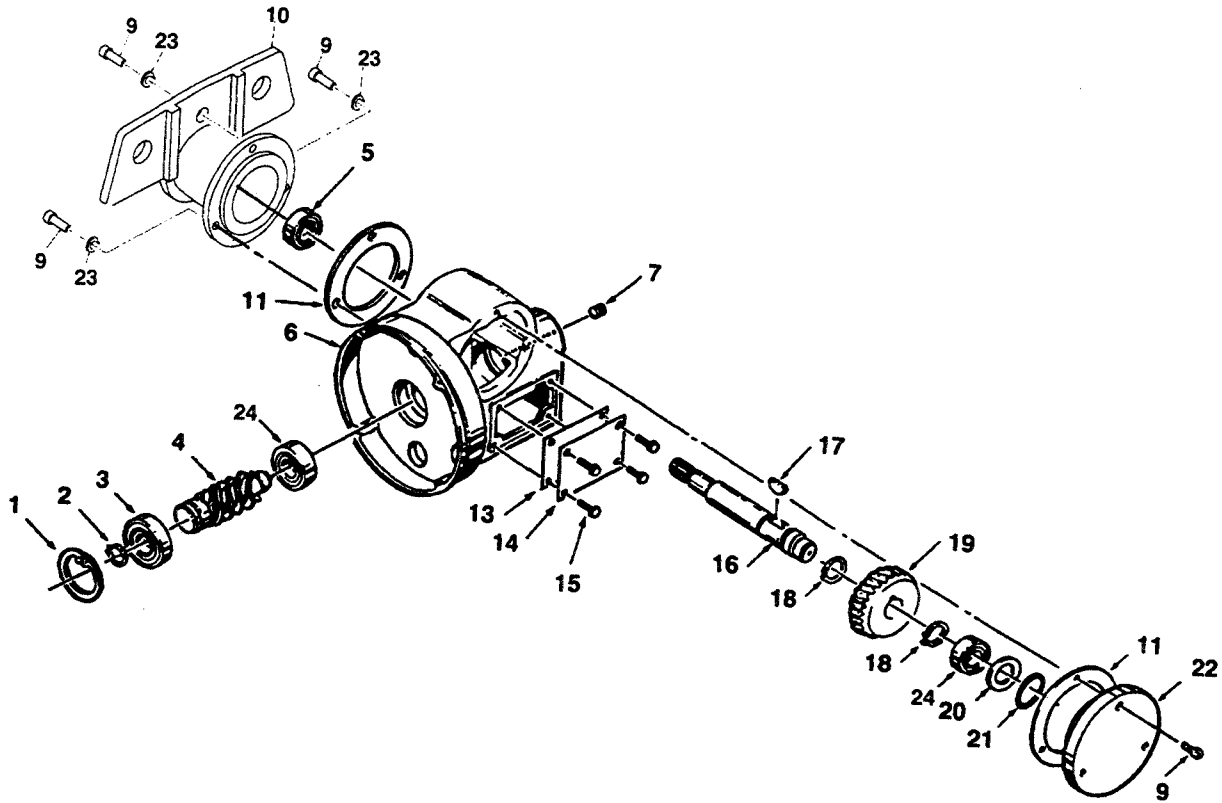


**FIGURE 8-10A. MOTORIZED TROLLEY
(SINGLE SPEED HOIST, SINGLE SPEED TROLLEY)**

Index No.	Part Name	Part No.
1	Pin, Load	103K1
2	Washer (1/8 thick)	H-4211
3	Washer (10 gal.)	H-4209
4	Washer (14 gal.)	H-4210
5	Pinion	420K1
6	Ring, Retaining	H-5501
7*	Cable Assembly, Tie 15 ft. Lift:	
	3-Phase, All HP	955JG33
	Single Phase, 1/2 HP	955JG31
	Single Phase, 3/4 & 1 HP	955JG35
	25 ft. Lift:	
	3-Phase, All HP	955JG34
	Single Phase, 1/2 HP	955JG32
	Single Phase, 3/4; 1 HP	955JG36
	Lifts Greater Than 25 ft.	Consult Factory
8*	Cap, Splice	H-7519
9*	Insulator, Splice Cap	H-7520
10	Nut, Elastic Stop	H-3945
11	Wheel:	
	Plain	45K10
	Drive	45K1
12	Axle	102K1
13	Spacer	200K1
14	Bearing	500K4
15	Ring, Retaining	H-5528
16	Washer (1/8 thick)	H-4211
17	Gear	420K2
18	Pin, Dowel	H-5531
19	Screw, Machine	H-2165
20*	Decal Coffing	677J7
22	Side Plate Weldment	5KG4

* Not Shown

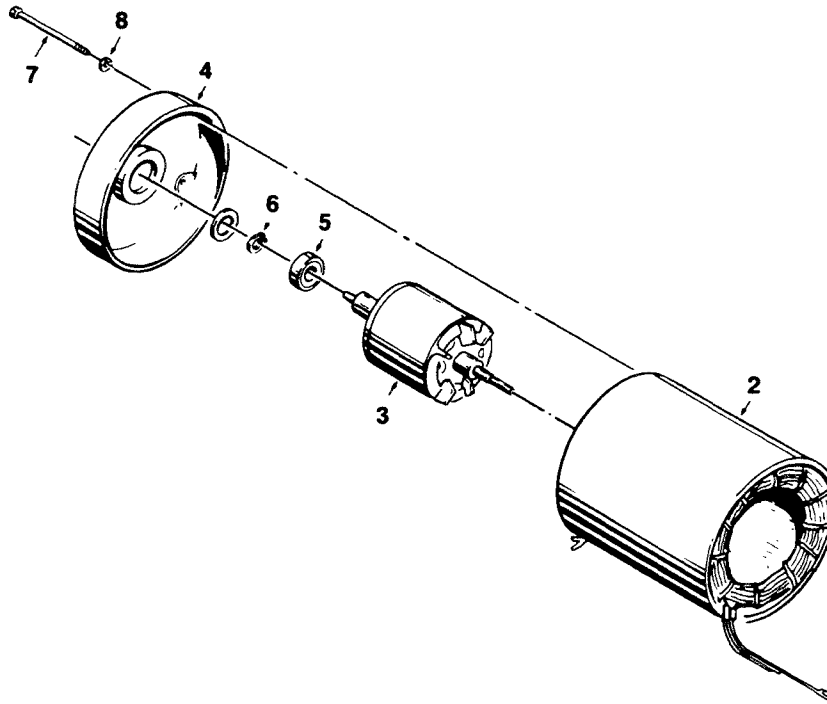
**FIGURE 8-10A. MOTORIZED TROLLEY
(SINGLE SPEED HOIST, SINGLE SPEED TROLLEY)**



Index No.	Part Name	Part No.
1	Retaining Ring	SK2658-6W
2	Retaining Ring	H-5549
3	Bearing	JF-504-2
4	Worm:	
	35 FPM	485K21
	75 FPM	485K22
5	Bearing	500K3
6	Gear Housing	39K22
7	Plug	S-25-13
9	Screw	H-2215
10	Adapter Housing	38K60A
11	Gasket	560K2

Index No.	Part Name	Part No.
13	Gasket	560K3
14	Splice Plate	295K1
15	Screw	H-1009-P
16	Shaft	100K12
17	Woodruff Key	S-23-15
18	Retaining Ring	H-5527
19	Worm Gear:	
	35 FPM	487K4
	75 FPM	487K3
20	Shim Washer	202K1
21	"O" Ring	H-5069
22	End Cap	32K3
23	Lockwasher	H-4084P
24	Bearing	500K7

FIGURE 8-11. TROLLEY TRANSMISSION



Index No.	Part Name	Part No.
1	Motor Complete:	
	Single Speed	
	208, 230/460V, 3-PH, 60 Hz, ¼ HP	JL-863-1M
	575V, 3-PH, 60Hz, ¼ HP	JL-863-5M
	Two Speed	
	208, 230V, 3-PH, 60 Hz, ¼ HP	JL-873-1M
460V, 3-PH, 60 Hz, ¼ HP	JL-873-5M	
575V, 3-PH, 60 Hz, ¼ HP	JL-873-9M	

Index No.	Part Name	Part No.
2	Stator (Not Available Separately)	*
3	Rotor & Shaft	*
4	End Shield	*
5	Bearing	*
6	Ring, Retaining	*
7	Screw, Motor Mount	*
8	Lock Washer	*

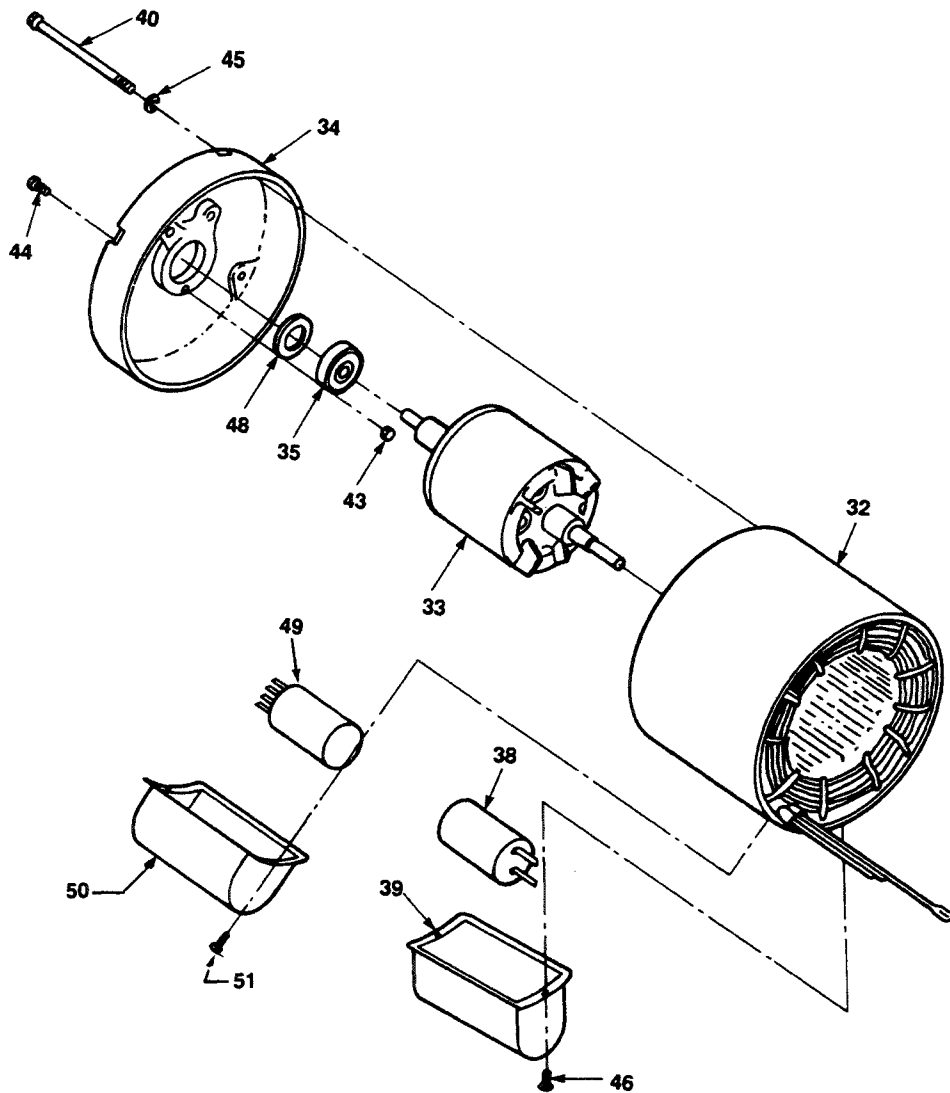
* For individual motor parts, contact your Duff-Norton Distributor and supply complete motor nameplate data.

**FIGURE 8-12A. TROLLEY MOTOR PARTS
(3 PHASE, SINGLE AND TWO SPEEDS)**

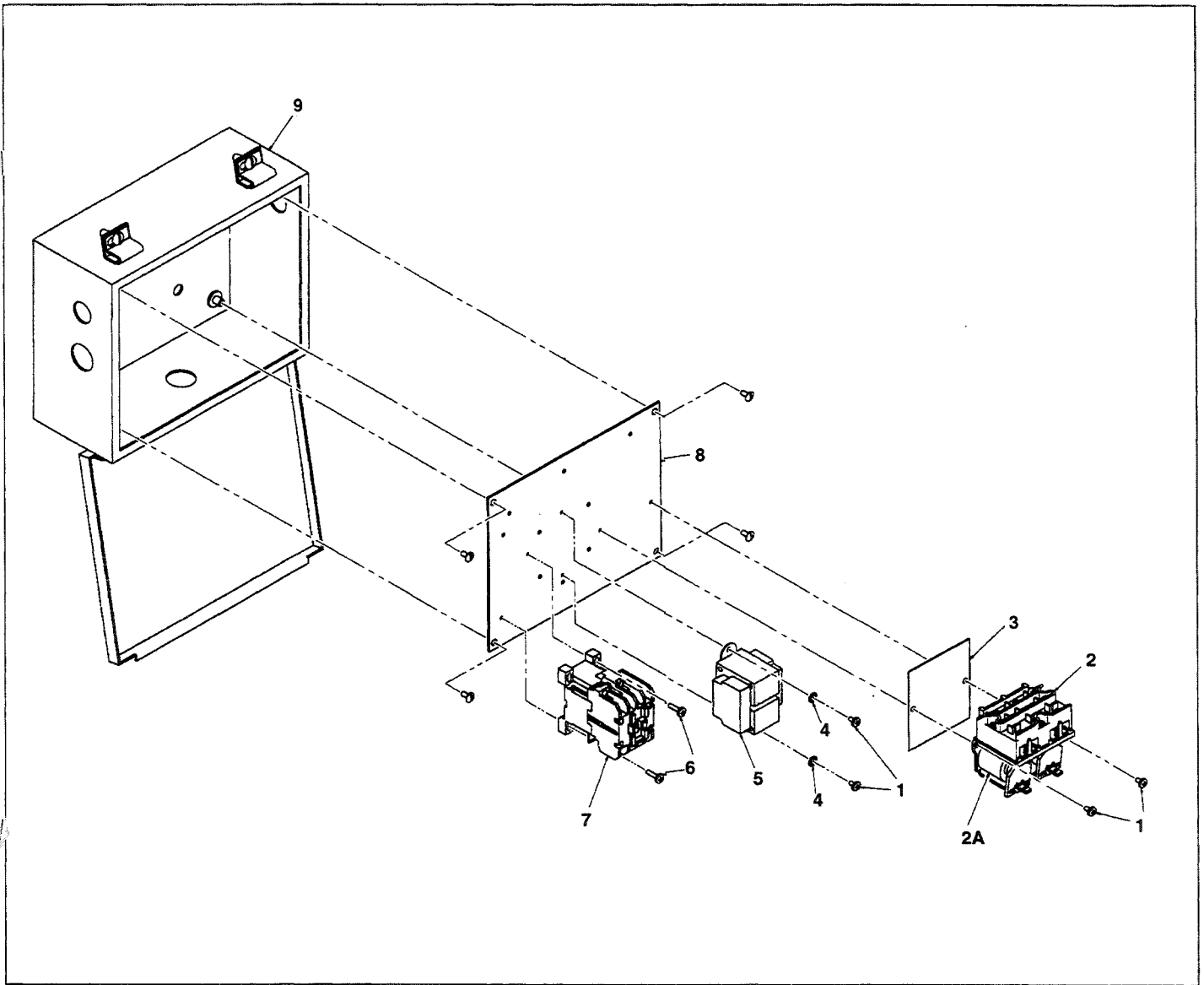
Index No.	Part Name	Part No.
31	JL-861-12	Motor, Complete: 1/2 HP, 115/230V, 60 Hz
31	JL-861-11M	Motor, Complete: 1/4 HP, 115/230V, 60 Hz
32	—	Stator (Not Available Separately)
33	*	Rotor & Shaft Assembly: 1/2 HP, 115/230V, 60 Hz 1/4 HP, 115/230V, 60 Hz
34	*	End Shield
35	500K3	Bearing
38	*	Capacitor: 1/2 HP
38	*	1/4 HP

Index No.	Part Name	Part No.
39	*	Capacitor Cover
40	*	Screw
42	732012	Rear Bearing
43	*	Nut Flange
44	*	Screw
45	H-4062-P	Lock Washer
46	*	Screw
48	*	Shim Washer
49	839J2	SINPAC® Switch
50	*	Cover
51	*	Screw

* Contact factory with complete electric motor nameplate data.



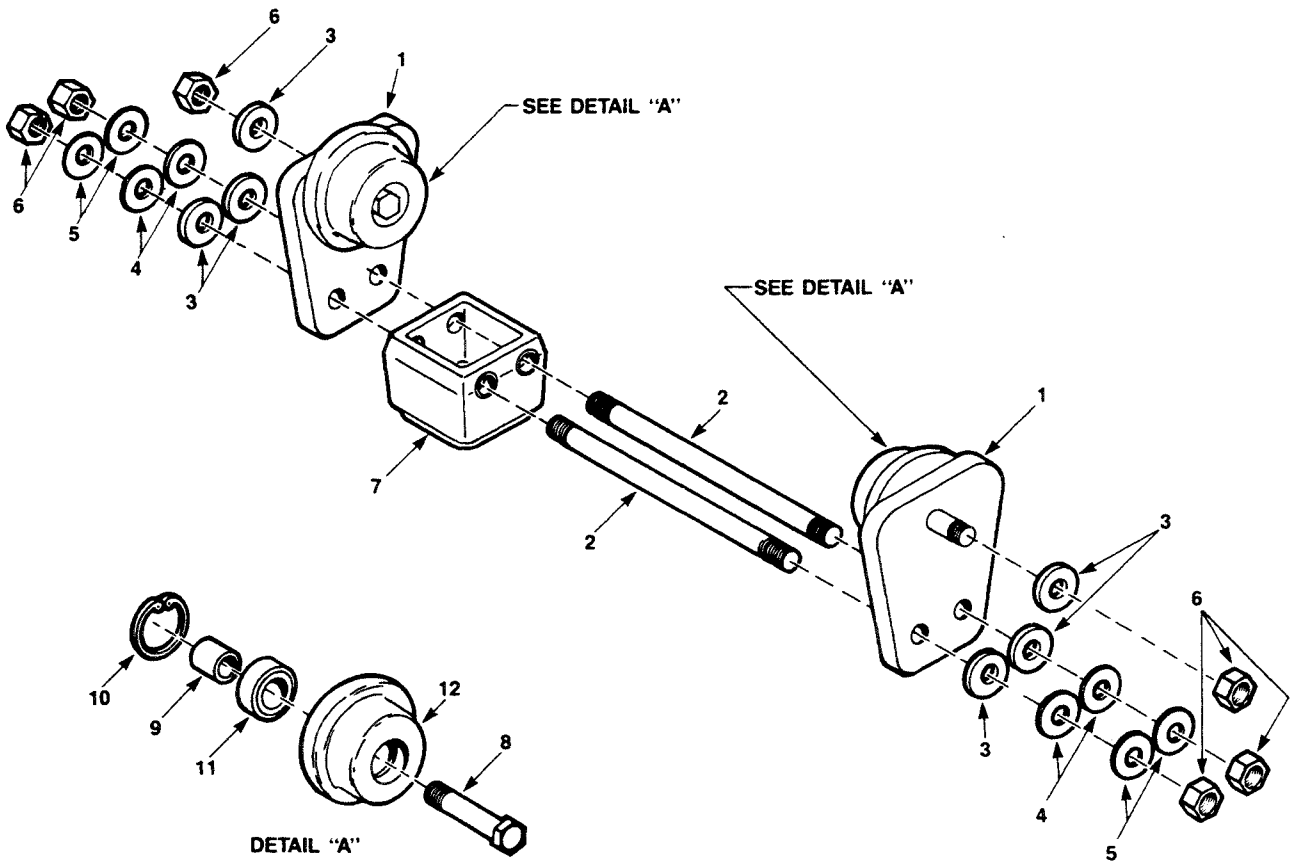
**FIGURE 8-12B. TROLLEY MOTOR PARTS
(1 Phase, Single Speed)**



Index No.	Part Name	Part No.
1	Screw	H-2742-P
2	Contactor (24V. Coils)	JF-829-1
	Contactor (115V. Coils)	JF-829
2A	Coil (24V.)	JF-37916-25
	Coil (115V.)	JF-37916-32
3	Insulator	JF-759-3
4	Lockwasher	H-4158
5	Transformer: (Single Speed)	
	Pri.: 230/460V, Sec.: 24V.	JL-821-432
	Pri.: 230/460V, Sec.: 115V.	JL-821-431
	Pri.: 575V, Sec.: 115V.	JL-821-452
	Pri.: 575V, Sec.: 115V.	JL-821-451
	Pri.: 208V, Sec.: 24V.	JL-821-472
	Pri.: 208V, Sec.: 115V.	JL-821-471

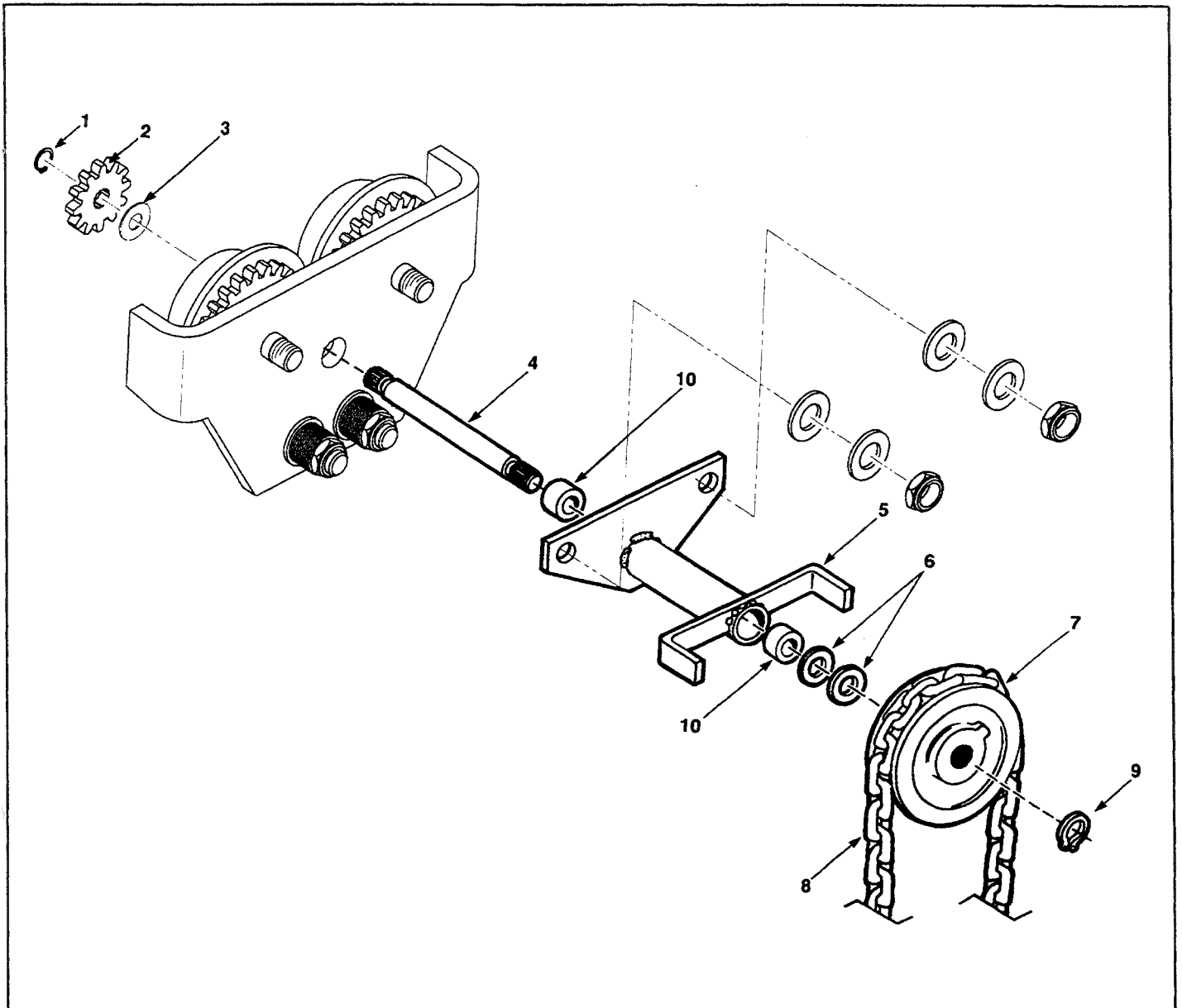
Index No.	Part Name	Part No.
5	Transformer: (Two Speed)	
(cont.)	Pri.: 230 or 460V, Sec.: 24V.	JL-821-432
	Pri.: 230 or 460V, Sec.: 115V.	JL-821-431
	Pri.: 575V, Sec.: 115V.	JL-821-452
	Pri.: 575V, Sec.: 115V.	JL-821-451
	Pri.: 208V, Sec.: 24V.	JL-821-472
	Pri.: 208V, Sec.: 115V.	JL-821-471
6	Screw	H-2752
7	Speed Relay (Two Speed)	
	Speed Relay (24V. Coil)	820J3
	Speed Relay (115V. Coil)	820J4
8	Speed Relay (24V. Coil)	257K615
9	Control Box	260K100-1

**FIGURE 8-13A. TROLLEY CONTROLS
(Single Speed or Two Speed Trolley)**



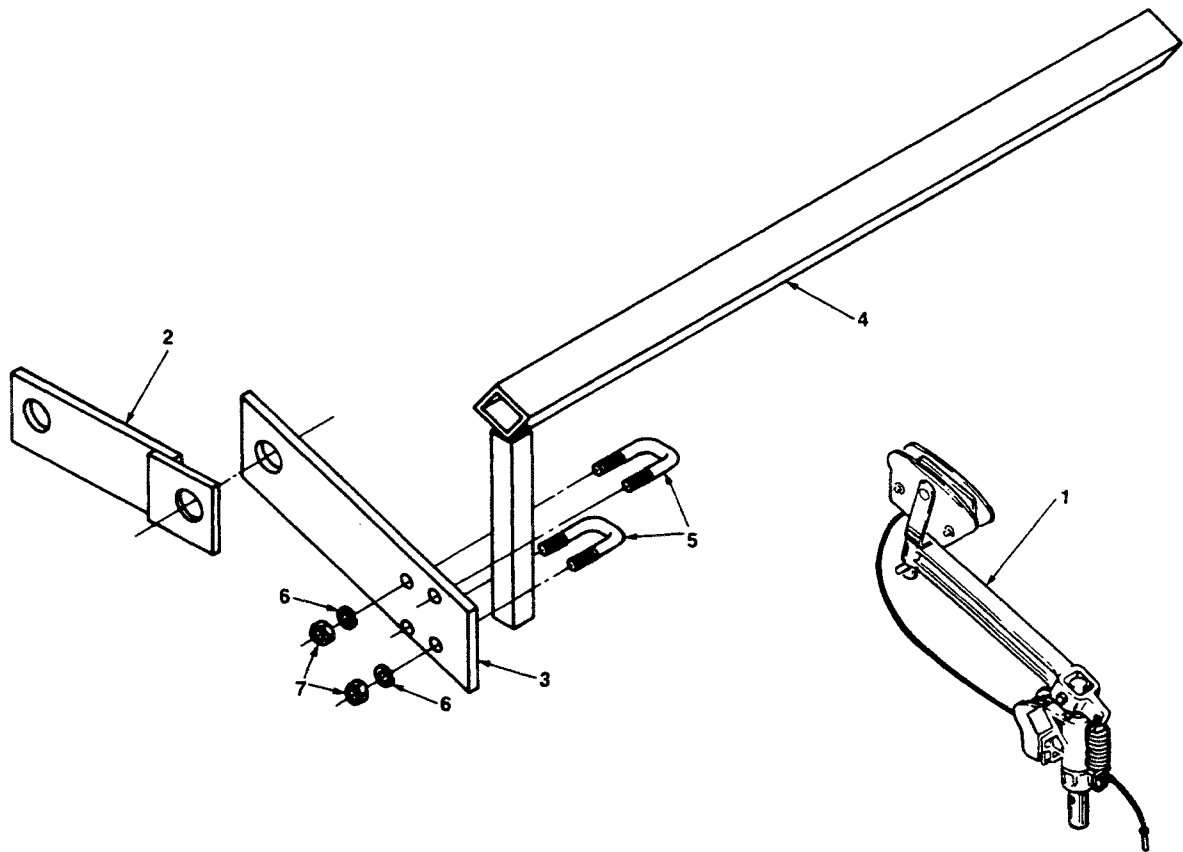
Index No.	Part Name	Part No.
1	Side Plate	5K56
2	Load Pin	103K1
3	Washer (1/8 thick)	H-4211
4	Washer (10 ga.)	H-4209
5	Washer (14 ga.)	H-4210
6	Nut	H-3945
7	Suspension Box (Ref. See Figure 8-5)	50J33
8	Axle	102K1
9	Spacer	200K1
10	Retaining Ring	H-5528
11	Bearing	500K4
12	Wheel	45K10

FIGURE 8-14. TWO-WHEEL TROLLEY



Index No.	Part Name	Part No.
1	Ring, Retaining	H-5501
2	Pinion	420K1
3	Spacer Bearing	525K2
4	Gear Shaft	100K14
5	Sleeve & Adapter Assembly	51KG1
6	Spacer Bearing	525K1
7	Hand-Chain Wheel	33K23
8	Hand-Chain (Specify Length)	53A
9	Retaining Ring	H-5527
10	Sleeve Bushing	530K6

FIGURE 8-15. GEARED TROLLEY



Index No.	Part Name	Part No.
1	Swivel Collector Assembly: Insul-8 Type	804K1
2	Brace Plate	802K12
3	Plate, Mounting	802K1
4	Arm, Mounting (20" long)	803KG8
5	Shackle, Mounting	806K1
6	Lock Washer	H-3561-P
7	Nut	H-3561
8	Collector Arm Kit Includes Index No's 2 thru 7	CCK2

FIGURE 8-16. CURRENT COLLECTOR GROUP

COFFING[®]

HOISTS

WARRANTY

Every hoist is thoroughly inspected and tested prior to shipment from the factory. Should any problem develop, return the complete hoist prepaid to your nearest Coffing Hoists Authorized Warranty Repair Station. If inspection reveals that the problem is caused by defective workmanship or material, repairs will be made without charge and the hoist will be returned, transportation prepaid. This warranty does not apply where: **(1)** deterioration is caused by normal wear, abuse, improper or inadequate power supply, eccentric or side loading, overloading, chemical or abrasive actions, improper maintenance, or excessive heat; **(2)** problems resulted from repairs,

modifications, or alterations made by persons other than factory or Coffing Authorized Warranty Repair Stations personnel; **(3)** the hoist has been abused or damaged as a result of an accident; **(4)** repair parts or accessories other than those supplied by Coffing Hoists are used on the hoist. Equipment and accessories not of the seller's manufacture are warranted by the manufacturer.

Except as stated herein, Coffing Hoists makes no other warranties, express or implied, including warranties or merchantability and fitness for a particular purpose.

⚠ WARNING

Overloading and Improper Use Can Result In Injury

To Avoid Injury:

- Do not exceed working load limit, load rating, or capacity.
- Do not use to lift people or loads over people.
- Use only alloy chain and attachments for overhead lifting.
- Read and follow all instructions.

Coffing Hoists • Country Club Road • P.O. Box 779 • Wadesboro, NC 28170 USA
Customer Service: Tel. (800) 477-5003 (704) 694-2156 • FAX (800) 374-6853 (704) 694-6829