

COFFING[®]

HOISTS

OPERATING & MAINTENANCE INSTRUCTIONS WITH PARTS LIST

Publication Part No. ESC-680-1

ESC - Electric Chain Hoists

For Capacities:

500 and 1000 Lbs. Capacity

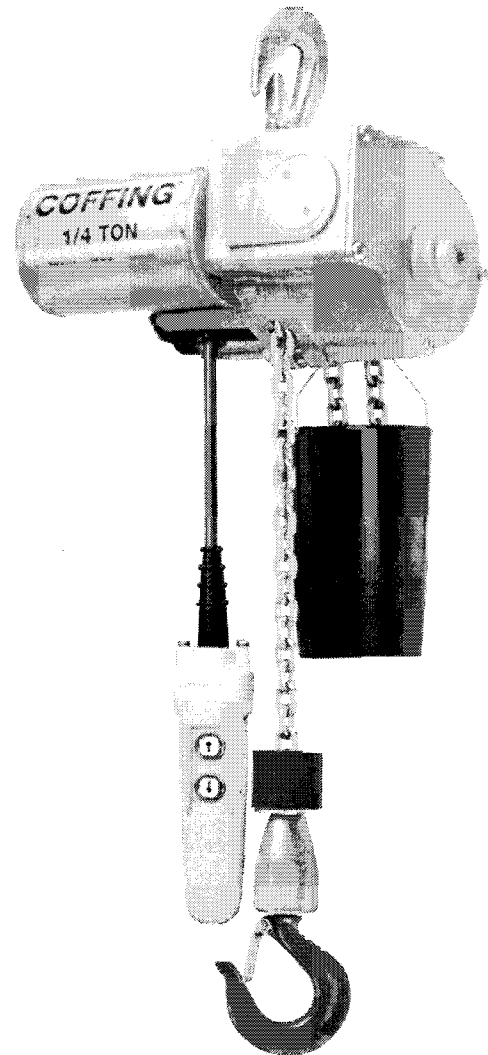

IMPORTANT—CAUTION

To safeguard against the possibility of personal injury or property damage, follow the recommendations and instructions of this manual. This manual contains important information for the correct installation, operation, and maintenance of this equipment. All persons involved in the installation, operation, and maintenance of this equipment should be thoroughly familiar with the contents of this manual. Keep this manual for reference and further use.

⚠ WARNING

To prevent personal injury, do not use the equipment shown in this manual to lift, support, or otherwise transport people, or to suspend unattended loads over people.

INDEX

Do's and Do Not's	2
Specifications	3
Description	3
General Safety Information	3
Installation	3
Operation	4
Maintenance	4
Recommended Inspection and Maintenance Check List	5
Recommended Inspector's Report	6
Exploded Illustration of Electric Chain Hoist	7
Replacement Parts List	8-10
Wiring Diagram	11
Warranty	Back Cover

DO'S AND DO NOT'S

Electric and Air Powered Hoists

The following warnings and operating practices have been taken from American National (Safety) Standards ANSI B30.16 and are intended to avoid unsafe hoisting practices which might lead to personal injury or property damage.

These recommendations apply to all electric and air powered hoists for vertical lifting service involving material handling of freely suspended unguided loads.

⚠ WARNING – TO AVOID INJURY

1. **DO** read ANSI B30.16 Safety Standard for Overhead Hoists and Hoist Manufacturer's Operating and Maintenance Instructions.
2. **DO** be familiar with hoist operating controls, procedures and warnings.
3. **DO** make sure hook travel is in the same direction as shown on controls.
4. **DO** make sure hoist limit switches function properly.
5. **DO** maintain firm footing when operating hoist.
6. **DO** make sure that load slings or other approved sling attachments are properly sized and seated in the hook saddle.
7. **DO** make sure that the hook latch, if used, is closed and not supporting any part of the load.
8. **DO** make sure that load is free to move and will clear all obstructions.
9. **DO** take up slack carefully, check load balance, lift a few inches and check load holding action before continuing.
10. **DO** avoid swinging of load or load hook.
11. **DO** make sure that all persons stay clear of the suspended load.
12. **DO** warn personnel of an approaching load.
13. **DO** protect wire rope and load chain from weld spatter or other damaging contaminants.
14. **DO** promptly report any malfunction, unusual performance, or damage of the hoist.
15. **DO** inspect hoist regularly, replace damaged or worn parts, and keep appropriate records of maintenance.
16. **DO** use the hoist manufacturer's recommended parts when repairing a hoist.
17. **DO** use hook latches wherever possible.
18. **DO** apply lubricant to the wire rope or load chain as recommended by the hoist manufacturer.
19. **DO NOT** lift more than rated load.
20. **DO NOT** use the hoist load limiting device to measure the load.
21. **DO NOT** use damaged hoist or hoist that is not working correctly.
22. **DO NOT** use the hoist with twisted, kinked, damaged or worn wire rope or chain.
23. **DO NOT** lift a load unless wire rope is properly seated in its groove(s) or unless chain is properly seated in chain wheel(s) or sprocket(s).
24. **DO NOT** use load rope or load chain as a sling or wrap rope or chain around the load.
25. **DO NOT** lift a load if any binding prevents equal loading on all supporting ropes or chains.
26. **DO NOT** apply the load to the tip of the hook.
27. **DO NOT** operate unless load is centered under hoist.
28. **DO NOT** allow your attention to be diverted from operating the hoist.
29. **DO NOT** operate the hoist beyond limits of load rope or load chain travel.
30. **DO NOT** use limit switches as routine operating stops unless recommended. They are emergency devices only.
31. **DO NOT** use hoist to lift, support or transport people.
32. **DO NOT** lift loads over people.
33. **DO NOT** leave a suspended load unattended unless specific precautions have been taken.
34. **DO NOT** allow sharp contact between two hoists or between hoist and obstructions.
35. **DO NOT** allow the rope, chain or hook to be used as a ground for welding.
36. **DO NOT** allow the rope, chain or hook to be touched by a live welding electrode.
37. **DO NOT** remove or obscure the warnings on the hoist.
38. **DO NOT** adjust or repair a hoist unless qualified to perform hoist maintenance.
39. **DO NOT** attempt to lengthen the load rope or chain or repair damaged load rope or chain.

SPECIFICATIONS

Model Number	Rated Load (lbs.)	Standard Lift (ft.)	Lifting Speed (FPM)	Voltage	Horse-power	Amp. Draw	Limit Switches	Head-room (in.)	Overall Dimensions (in.)	Net Weight (lbs.)
0512-10	500	10	12	115V	.3	4.0	Upper & Lower	15	4 ¹ / ₄ H x 5 ¹ / ₄ W x 9 ³ / ₄ L	16
0512-10 (230)	500	10	12	230V	.3	4.0	Upper & Lower	15	4 ¹ / ₄ H x 5 ¹ / ₄ W x 9 ³ / ₄ L	26
0512-20	500	20	12	115V	.3	4.0	Upper & Lower	15	4 ¹ / ₄ H x 5 ¹ / ₄ W x 9 ³ / ₄ L	18
0512-20 (230)	500	20	12	230V	.3	4.0	Upper & Lower	15	4 ¹ / ₄ H x 5 ¹ / ₄ W x 9 ³ / ₄ L	28
1006-10	1000	10	6	115V	.3	4.0	Upper & Lower	15	4 ¹ / ₄ H x 5 ¹ / ₄ W x 9 ³ / ₄ L	20
1006-10 (230)	1000	10	6	230V	.3	4.0	Upper & Lower	15	4 ¹ / ₄ H x 5 ¹ / ₄ W x 9 ³ / ₄ L	30

Push button drop is approximately 4 feet less than lift.

A transformer is supplied for 230 volt applications.

4 mm link chain (welded and heat treated) minimum breaking strength 3,400 lbs.

OPERATING INSTRUCTIONS

Description

This electric chain hoist features self-locking, hardened steel gears that also function as a brake. The hoist is equipped with electronic overload protection, adjustable upper and lower limit switches, permanently lubricated and hardened steel gear train, and three-wire pendant control.

General Safety Information

This hoist is designed for safe operation within the limits of its rated capacity. There are safety features built into the hoist to protect the operator and others from injury due to failure of the hoist itself. However, listed below are safety precautions which must be followed in order to protect personnel and property.

1. Align hoist for straight line pull. Avoid side pulls and pulling horizontally.
2. Limit switches are emergency devices only. Do not use limit switches to stop the hoist in normal operation. Repeated actuation of these limit switches under load could damage the hoist.
3. Do not operate hoist with twisted, kinked, or damaged chain.
4. Do not operate a damaged or malfunctioning hoist until adjustments or repairs have been made.
5. Do not use hoist to lift people or carry loads over people.
6. Do not lift more than rated capacity of the hoist.
7. Do not leave a load suspended in the air unattended.
8. Avoid jogging controls or quick reversals of load.
9. Always remove load and disconnect hoist from power supply before making repairs.
10. Read ANSI Safety Standard B30.16

⚠ WARNING DO NOT USE HOIST FOR MOVEMENT OF PERSONNEL OR LOADS OVER PERSONNEL. DO NOT OPERATE HOIST IN AN EXPLOSIVE ATMOSPHERE OR CORROSIVE ENVIRONMENT.

11. Do not replace chain supplied with hoist with any other type.
12. Do not attempt to operate hoist on any other power supply other than 115 volt, 50/60 Hz, single phase.

INSTALLATION

Mounting

The hoist must be hung by the upper hook only, and should not be mounted by any other means. The mounting support must be capable of handling loads in excess of hoist rating. Suggested locations are on a support beam or trolley.

Electrical Connection

This hoist is to be connected to a 115-volt A.C., single phase, 50/60 Hz current only. The outlet must be grounded.

Limit Switches

The hoist is equipped with an upper and lower limit switch. The upper switch is intended as an emergency shut-off to limit the upward travel of the load hook and should not be used during normal operation of the hoist. The lower limit switch is also intended as an “emergency only” stop and should not be used during normal operation of the hoist. Repeated use of the upper and lower limit switch under load can cause shock loads that could damage the hoist.

If one of the limit switches has been activated, do not attempt to continue hoist movement in the same direction. Hoist must be reversed. Continued attempts to operate the hoist in the direction of the activated limit will break limit switch arm. A broken arm on limit switch is not covered by warranty.

Chain Bucket

A chain bucket is standard equipment and may be used when slack chain hanging from hoist is not desired. Note how the hook is fastened to the bucket before removing it for installation on the hoist. To install, feed the hook through the third link down of the fixed chain end. Attach hook to the bucket by inserting hook ends through the **TOP** of the tabs at the bucket rim.

OPERATION

This hoist is operated by the pendant station at the end of the control cord.

To raise a load, press the button marked “▲” (up). To lower a load, press the button marked “▼” (down). The load will stop and hold from either direction by releasing the button.

A load, whether being raised or lowered, will stop in approximately 1/8 inch when the push button is released. At this point, the motor and face gears are locked and the load will remain in position until the control switch is again activated.

Duty Cycle

This is an intermittent duty hoist. Exceeding this duty cycle will cause overheating of the gear box and the motor. Overheated gears thin out the lubricant causing excessive wear on the gears. An overheated motor breaks down insulation on the winding causing premature motor failure. A temperature sensing device built into the hoist will indicate if the duty cycle has been exceeded. **EXCEEDING THE DUTY CYCLE VOIDS THE WARRANTY.** Therefore, it is very important to allow sufficient time for the motor and gear box to cool down after each usage. The following chart gives recommended rest periods for varying amounts of usage. Do not operate the hoist over 2 minutes at full load.

Motor “On” Time (Minutes)	Vertical Travel Distance (Feet)		Cool Down Period (Minutes)	
	500 lb. Hoist	1,000 lb. Hoist	Full Rated Load	Half Rated Load
1/4	3	1 1/2	1	1/2
1/2	6	3	3	1 1/2
1	12	6	7	3 1/2
2*	24	12	15	7 1/2

*Do Not Exceed 2 Minutes “on” Time

Trouble Shooting

If hoist operates in one direction only, check for a jammed limit switch arm. This can be done by removing the limit switch cover.

If hoist starts to lift a heavy load and then stops, check the overload light while pressing the “▲” button. If the light comes on, then lower and reduce the load and repeat the procedure.

MAINTENANCE

On a daily basis, the following should be checked:

1. Controls — Check all controls and operating mechanisms for proper function.
2. Safety Devices — Check upper and lower limit switches for proper function.

3. Hooks — Check for cracks or deformation.
4. Chain — Inspect for wear, distortion, and proper attachment at each end. Check for dirt and foreign matter on chain that can be carried back into hoist.

On a periodic basis (suggested intervals of one to three months, depending on service), the following should be checked:

1. Bolts, screws, and connections for any loosening.
2. Pocket wheel for wear.
3. Wear of chain, including chain stretch. Chain stretch can be checked by measuring 11 links (inside to inside) of a section of chain that normally runs over the pocket wheel.

This hoist is equipped with a 4 MM welded link chain with a .472 nom. pitch; therefore, 11 links of a new chain should measure 5.197 +.016 –.008 inches.

If any 11 links of chain measure more than 5.275 inches, then stretch and wear is excessive and the chain must be replaced.

4. Hooks — Check for cracks with dye penetrants, magnetic particles, or other suitable methods at least once a year.
5. Check electrical components for corrosion or other signs of deterioration.
6. Check hook retaining pins for wear and secureness.

Testing

After repair, check to see that the welds on each chain link face away from the pocket wheel. After repair or modification of a hoist, it must be tested for proper operation. Begin test with a light load and increase to rated capacity. Test should also include operation of upper and lower limit switch.

Lubrication

If lubrication of the gearbox is required because of unusual conditions, then use only grease Part No. 911502000. This is the only grease approved for use in the hoist.

The chain should be lubricated with SAE 20-30 grade motor oil.

Hook Throat Opening

Use the table below to check hook throat opening (with latch).

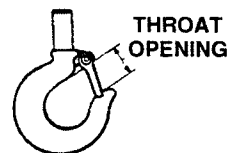

Maximum Allowable Hook Throat Opening

Hoist Load Rating (ton)	Top Hook (in.)		Bottom Hook (in.)	
	Normal	Reject	Normal	Reject
1/4 & 1/2	0.8	1.0	0.8	1.0

INSPECTION & MAINTENANCE CHECK LIST ELECTRIC POWERED OVERHEAD CHAIN HOIST

Type of Hoist _____
 Location _____
 Manufacturer _____

Capacity (Tons) _____
 Original Installation Date _____
 Manufacturer's Serial No. _____

Item	Frequency of Inspection			Possible Deficiencies	OK	Action Required
	Frequent		Periodic 1-12 Mo.			
	Daily	Monthly				
Operating Controls	•	•	•	Any deficiency causing improper operation		
Limit Switches	•	•	•	Any deficiency causing improper operation Pitting or deterioration		
Hooks	•	•	•	Excessive throat opening, bent or twisted more than 10 degrees, damaged hook latch, wear, chemical damage, worn hook bearing Cracks (use dye penetrant, magnetic particle or other suitable detection method)		
Chain	•	•	•	Inadequate lubrication, excessive wear or stretch, cracked, damaged or twisted links, corrosion or foreign substance		
Hook & Suspension Connections			•	Cracks, bending, stripped threads, loose mounting screws		
Pins, Bearing, Bushings, Shafts, Couplings, Chain Guides			•	Excessive wear, corrosion, cracks, distortion		
Nuts, Bolts, Rivets			•	Looseness, stripped and damaged threads, corrosion		
Sheaves			•	Distortion, cracks, and excessive wear Build up of foreign substances		
Housings, Load Block			•	Distortion, cracks, and excessive wear Internal build up of foreign substances		
Wiring & Terminals			•	Fraying, defective insulation		
Contact Block, Magnetic Hoist Control Switch, Other Electronic Apparatus			•	Loose connections, burned or pitted contacts		
Supporting Structure & Trolley (if used)			•	Damage or wear which restricts ability to support imposed loads		
Nameplates, Decals, Warning Labels			•	Missing, damaged or illegible		
Transmission Lubricant			•	Low level, contamination, improper grease		

NOTE: Refer to Maintenance and Inspection Sections of the Hoist Maintenance Manual for further details.

FREQUENCY OF INSPECTION

Frequent - Indicates items requiring inspections daily to monthly. Daily inspections may be performed by the operator if properly designated.

Periodic - Indicates items requiring inspection monthly to yearly. Inspections to be performed by or under the direction of a properly designated person. The exact period of inspection will depend on frequency and type of usage. Determination of this period will be based on the user's experience. It is recommended that the user begin with a monthly inspection and extend the periods to quarterly, semi-annually, or annually based on his monthly experience.

RECOMMENDED INSPECTION AND MAINTENANCE CHECK LIST

ELECTRIC CHAIN HOIST

1000 POUND
RATED LOAD

500 POUND
RATED LOAD

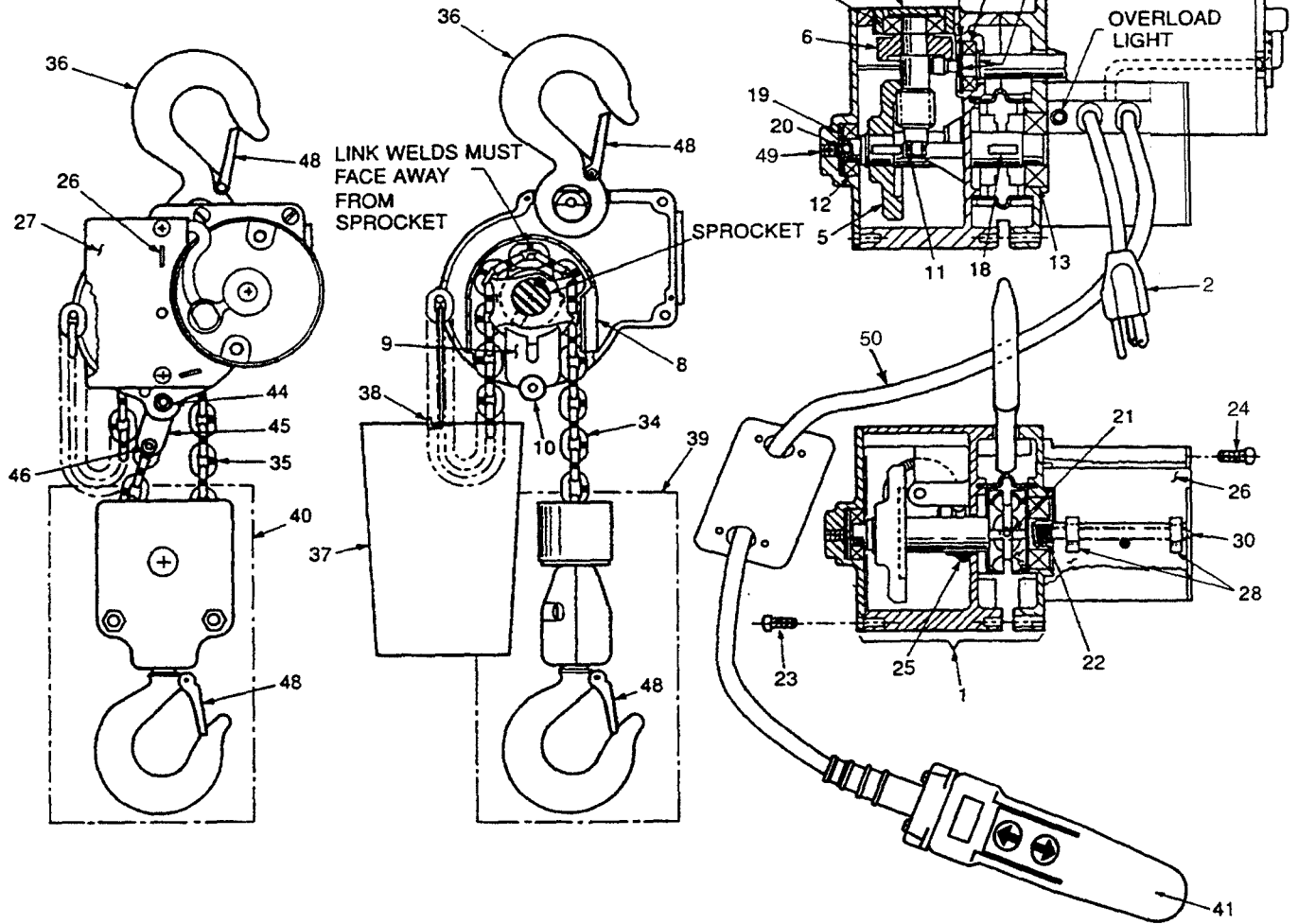

REPLACEMENT PARTS LIST

Key No.	Part No.	Description	Quantity Required
1	914500400	Housing & Sprocket Cover	1
2	912307401	Power Cord	1
5	912501300	Sprocket Shaft & Gear Ass'y.	1
6	912501200	Primary Gear & Pinion Ass'y.	1
7	911500200	Adjusting Plug	1
8	911500902	Chain Guide	1
9	911501000	Chain Stripper	1
10	911501200	Spacer (500 Lb. Hoist)	1
11	912304115	Needle Bearing	1
12	912307904	Ball Bearing	1
13	912307905	Ball Bearing	1
14	912307906	Ball Bearing	1
15	912307903	Ball Bearing	1
16	912302912	Retaining Ring	1
17	912302910	Retaining Ring	2
18	912303502	Woodruff Key	2
19	911501100	Spacer (Gear Cover)	1
20	911500800	Shaft Adj. Ball	1
21	912316403	Set Screw 1/4 - 20 x 1/4	1
22	912316402	Set Screw 1/2 - 13 - 3/8	1
23	912303002	Screw 10-32 x 1/2	5
24	H2708	Screw 10-32 x 1 3/4	2
25	912500901	Checkseal	1
26	89L1	Guide Plate	1
27	36L1	Limit Switch Housing Cover	1
28	911501603	Limit Switch Arm	2
30	117L1	Limit Switch Drive Screw	1
32	913204600	Motor	1
34	912501804	Chain (4 MM x 11 Ft.)	1
35	912501805	Chain (4 MM x 21 Ft.)	1
36	3C302C01S	Top Hook (with Safety Latch)	1
37A	912502000	Chain Bucket	1
37B	912502100	Chain Bag	1
38A	911501700	Hanger, Chain Bucket	1
38B	911502400	Hanger, Chain Bag	1
39	*912502200	Clevis & Hook Ass'y. 500 Lb. Hoist	1
39A	3M002C02S	Hook & Latch Ass'y. (Part of Key #39)	1
39B	912501700	Clevis Half (Part of Key #39)	2
39C	911232500	Bumper (Part of Key #39)	1
39D	932312014	Flat Washer (Part of Key #39)	1
39E	912306604	Dowel Pin (Part of Key #39)	1
40	*913500500	Pulley Block Ass'y. 1000 Lb. Hoist	1
40A	3M002C02S	Hook & Latch Ass'y. (Part of Key #40)	1
40B	911500100	Sprocket (Part of Key #40)	1
40C	911501800	Pin Pulley Block (Part of Key #40)	1
40D	913500300	Block Half (Part of Key #40)	2
41	534L1	Pendant Station	1
42	911502000	Synco TFE Grease (Not Shown)	3 cu/in
43	912305802	Cable Tie (Not Shown)	1
44	912305505	Screw, Hex Socket Hd. Cap	1
45	911503100	Clevis	1
46	912305504	Screw, Hex Socket Hd. Cap	1
47	912307303	Hex Nut Prevailing Torque (Not Shown)	1
48	123J002	Hook Latch Kit	2
49	912316408	Screw 5/16 - 24 x 3/8	1
50A	H6041	Pushbutton Cord For 10 Ft. of Lift	6.5 ft.
50B	H6041	Pushbutton Cord For 20 Ft. of Lift	16.5 ft.

*See Assembly Breakdown for Individual Parts List.

REPLACEMENT PARTS LIST

Part Number	Description
901244400	Label (Destruction of This Seal)
3M002C01S	Bottom Hook & Latch Assembly
124K2	Hook Collar
911234700	Label (500 Lbs. Capacity)
911236800	Label (1000 Lbs. Capacity)
911501500	Strain Relief Bracket
911501900	Temperature Monitoring Dot — 170°F
911502500	Corrugated Insert
911502900	Tag (Designed For Intermittent Use)
911503000	Stainless Steel Hoop Canvas Chain Bag
H5159	Roll Pin
912302711	Thrust Washer
912302909	Retaining Ring
912303001	Screw
912303101	Carton
912303212	Grounding Screw
912303302	Thrust Bearing
H3561P	Hex Nut
912304603	Electrical Wire (TFFN Black 18 GA)
912305503	Socket Head Cap Screw
912305706	Lock Washer
912306601	Dowel Pin
912307506	Strain Relief Bushing
912307611	Terminal Ring #8
912325401	Rubber Grommet
912500100	Motor Pinion
912500200	Gear #1 Small Helical
912500300	Secondary Pinion Gear
912500400	Secondary Gear
912500500	Sprocket Shaft
849L1	Potting Capsule Container
*534LG1	Pendant & Cable Assembly (10 Ft. Lift)
*534LG1-2	Pendant & Cable Assembly (20 Ft. Lift)
687K3	Tag (Warning: When Operating Hoist)
912502700	Transformer (230V in/115V out)
839LG1	Control Module with Potting Capsule
914500200	Housing
914500300	Sprocket Cover
130039	Motor Brushes (2 per motor)
951LG1	Power Cord

*See Assembly Breakdown for Individual Parts List.

ASSEMBLY BREAKDOWN LIST

Part Number	Assembly Description	Consists Of	Description	Qty.
3M002C02S	Bottom Block Hook Assembly	3M002C01S	Bottom Hook & Latch Assembly	1
		124K2	Hook Collar	1
		H5159	Roll Pin	1
		912302711	Thrust Washer	1
		912303302	Thrust Bearing	1
912501200	Gear #1 & Secondary Pinion Assembly	912500200	Gear #1	1
		912500300	Secondary Pinion Gear	1
912501300	Sprocket Shaft & Secondary Gear Ass'y.	912302909	Retaining Ring	1
		912303502	Woodruff Key	2
		912500400	Secondary Gear	1
		912500500	Sprocket Shaft	1
		912500901	Checkseal	1
912502200	500 Lb. Swivel Clevis & Hook Ass'y.	912303001	Screw	2
		912306604	Dowel Pin	1
		3M002C02S	Bottom Block Hook Ass'y.	1
		912312014	Plated Flat Washer	1
		912501700	Swivel Clevis Half	2
		911232500	Bumper	1
534LG1	Pendant & Cable Ass'y. (10 Ft. Lift)	534L1	Pendant Station	1
		687K3	Tag (Warning)	1
		H6041	Electrical Cable	6.5 ft.
		H5814	Terminal	3
		H5813	Terminal	3
534LG1-2	Pendant & Cable Ass'y. (20 Ft. Lift)	534L1	Pendant Station	1
		687K3	Tag (Warning)	1
		H6041	Electrical Cable	16.5 ft.
		H5814	Terminal	3
		H5813	Terminal	3
913500500	Pulley Block Ass'y. (1000 Lbs. Capacity)	911500100	Sprocket Wheel	1
		911501800	Pulley Block Pin	1
		H3561P	Hex Nut	2
		912305503	Socket Head Cap Screw	2
		912305706	Lock Washer	2
		3M002C02S	Bottom Block Hook Ass'y.	1
		913500300	Block Half (1000 Lbs. Capacity)	2

WIRING DIAGRAM — SINGLE SPEED HOIST

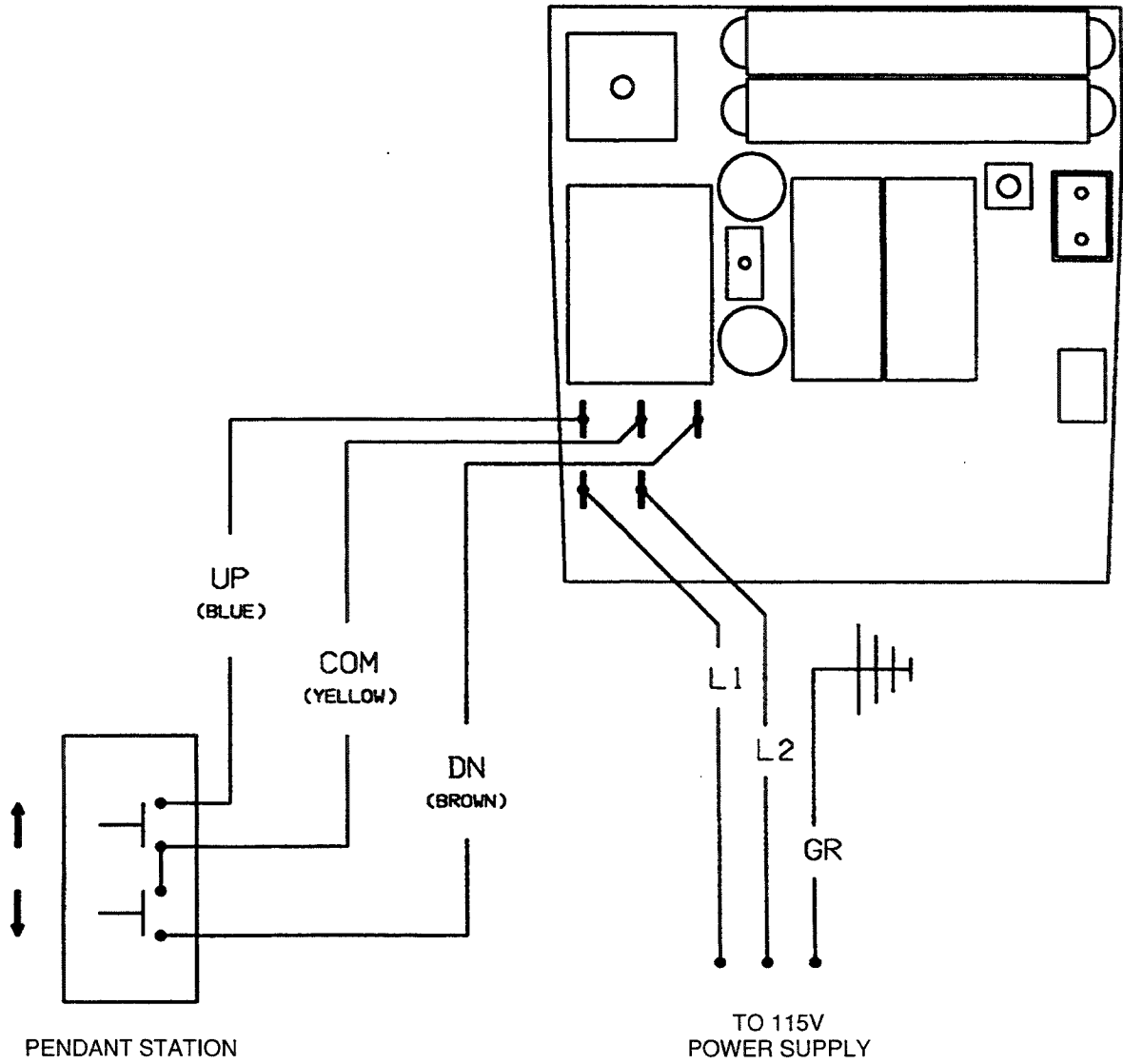

COFFING[®]

HOISTS

WARRANTY

Every hoist is thoroughly inspected and tested prior to shipment from the factory. Should any problem develop, return the complete hoist prepaid to your nearest Coffing Hoists Authorized Warranty Repair Station. If inspection reveals that the problem is caused by defective workmanship or material, repairs will be made without charge and the hoist will be returned, transportation prepaid. This warranty does not apply where: **(1)** deterioration is caused by normal wear, abuse, improper or inadequate power supply, eccentric or side loading, overloading, chemical or abrasive actions, improper maintenance, or excessive heat; **(2)** problems resulted from repairs,

modifications, or alterations made by persons other than factory or Coffing Authorized Warranty Repair Stations personnel; **(3)** the hoist has been abused or damaged as a result of an accident; **(4)** repair parts or accessories other than those supplied by Coffing Hoists are used on the hoist. Equipment and accessories not of the seller's manufacture are warranted by the manufacturer.

Except as stated herein, Coffing Hoists makes no other warranties, express or implied, including warranties or merchantability and fitness for a particular purpose.

WARNING

Overloading and Improper Use Can Result In Injury

To Avoid Injury:

- Do not exceed working load limit, load rating, or capacity.
- Do not use to lift people or loads over people.
- Use only alloy chain and attachments for overhead lifting.
- Read and follow all instructions.

Coffing Hoists • Country Club Road • P.O. Box 779 • Wadesboro, NC 28170 USA
Customer Service: Tel. (800) 477-5003 (704) 694-2156 • FAX (800) 374-6853 (704) 694-6829