

The Powerstar Electric Chain Hoist models have been expanded to include 7 1/2, 9, 10 and 12 ton capacity, multi-reeved units. This supplement contains information on, and a parts list of, the additional components for these multi-reeved units, and it should be used in conjunction with Operating, Maintenance and Parts Manual No. 670.

The 7 1/2, 9 and 10* ton capacity hoists are 3-part single reeved units and the 12 ton hoist is a 4-part single reeved unit. The frames, gears, chain, brake, covers, shroud, limit switches and electrical components are similar to those shown and described in Manual Number 670. In addition the electrical data, wiring diagrams and trouble shooting data of Manual Number 670 also apply to these multi-reeved units.

The multi-reeved units are furnished with plain, geared or motor driven trolleys. The basic components for these trolleys are similar to those shown in Manual Number 670.

When ordering repair parts, use the part list and drawings in this supplement. If the particular part is not listed in this supplement, then refer to the Manual Number 670. To ensure that the correct parts are furnished, always specify the capacity, lift, serial number and power supply of the unit on your repair part order. The parts used in the multi-reeved units are not always the same as those used in the 2 thru 6 ton capacity units shown in Manual Number 670.

Before attempting to install or use the hoist, all persons who will install, operate or maintain the unit should read Manual Number 670 as well as this supplement thoroughly to avoid damage or injury.

This supplement follows the general format of Manual Number 670 and provides superseding or additional information to cover the multi-reeved units.

*A 10 ton hoist rated in metric tons is a 4-part single reeved unit.

INSTALLATION

Follow the general instructions for installing trolley supported hoists in Manual Number 670. However, use Table 1 to determine the arrangement of the spacer washers. It should be noted that spacer washers must also be used at the

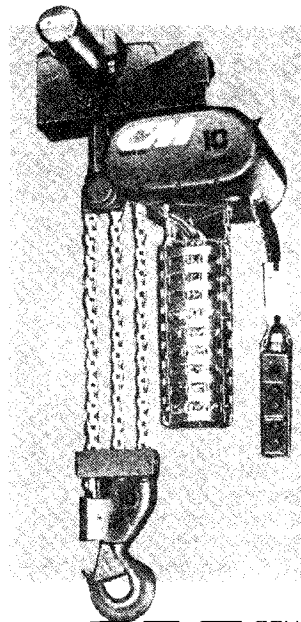

CM COLUMBUS MCKINNON CORPORATION
INDUSTRIAL PRODUCTS DIVISION
140 JOHN JAMES AUDUBON PARKWAY
AMHERST, NEW YORK 14228-1197
716/689-5500 FAX, 716/689-5644

CAUTION - IMPORTANT:

If not properly installed, operated and maintained, the use of all mechanical equipment presents the possibility of personal injury or property damage. Before hoist use, all persons who will install, operate and maintain should read this manual thoroughly. For safe, dependable and economical performance, follow all instructions and recommendations contained herein. It is also important to retain this manual for current and future use.

sheave hanger (3 and 4-part reeved units) and at the dead end hanger (4-part reeved units only). The arrangements of the spacer washers at these locations must be the same as those at the hoist suspension bolts.

Table 1. Trolley Spacer Washer Arrangement

Capacity	7 1/2 Ton								9 or 10 Ton								10 or 12 Ton							
	3-Part Single								3-Part Single								4-Part Single							
	Plain				Geared or Motor Driven				Plain				Geared or Motor Driven				Plain				Geared or Motor Driven			
Type of Trolley	No. of Washers								No. of Washers								No. of Washers							
*Flange Width (In.)	A	B	C	D	A	B	C	D	A	B	C	D	A	B	C	D	A	B	C	D	A	B	C	D
5-1/2	10	0	0	0	10	8	0	0	8															
5-5/8	10	0	1	9	8	0	1	7																
6	9	1	2	8	7	1	2	6	10	0	0	10	8	0	0	8								
6-1/4	8	2	3	7	6	2	3	5	9	1	1	9	7	1	1	7								
6-3/8	7	3	3	7	5	3	3	5	8	2	1	9	6	2	1	7								
7	5	5	5	5	3	5	5	3	6	4	3	7	4	4	3	5	10	0	0	10	8	0	0	8
7-1/8	5	5	6	4	3	5	6	2	6	4	4	6	4	4	4	4	9	1	0	10	7	1	0	8
7-1/4	4	6	6	4	2	6	6	2	5	5	4	6	4	4	5	3	9	1	1	9	7	1	1	7
7-3/8	4	6	7	3	2	6	7	1	5	5	5	5	3	5	5	3	8	2	1	9	6	2	1	7
7-1/2	3	7	7	3	1	7	7	1	4	6	5	5	3	5	6	2	8	2	2	8	6	2	2	6
7-5/8									4	6	6	4	2	6	6	2	7	3	2	8	5	3	2	6
7-7/8									3	7	7	3	2	6	7	1	6	4	3	7	4	4	3	5
8									2	8	7	3	1	7	7	1	6	4	4	6	4	4	4	4
8-1/4																	5	5	5	5	3	5	5	3
8-1/2																	4	6	6	4	2	6	6	2
8-3/4																	3	7	7	3	2	6	7	1
9																	2	8	8	2	1	7	7	1

Minimum Radius Curve = 10' 0"

*American Standard "S" beams for flange widths up to 8". Wide flange beams for flange widths over 8".

Operating, Maintenance and Parts Manual Powerstar

Electric Chain Hoist Capacities:
7 1/2, 9,
10 & 12 Ton

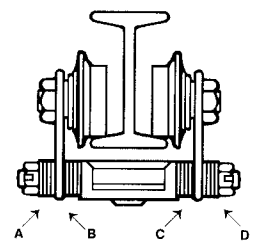

Plain Trolley

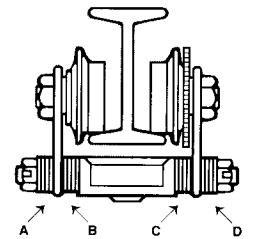

Geared and Motor Driven Trolleys

Checking for Twist in Load Chain

Do not operate if twisted.

On the 3-part single reeved units, the load chain is dead ended on the hook block. On the 4-part single reeved unit, the load chain is dead ended on a hanger suspended from the trolley. If the chain has been properly installed, the only way a twist can occur is if the lower hook block has been capsized between the strands of the load chain. If this has occurred, the strands of chain will be wrapped around each other, and to remove this, reverse the capsizes.

Chain Container

Each hoist is furnished with a chain container that must be attached to the hoist at installation. An "X" frame and chute are attached to the bottom of the hoist at the factory and the chain container, along with attaching hardware, are shipped loose. After the hoist and trolley are installed and the electrical connections are properly completed, operate the hoist in the down direction until the lower limit switch stops the downward motion.

Disregard the chain container installation instructions in Manual Number 670 and attach the 8 chain container support chains to the four legs of the "X" frame as illustrated in Figure 1.

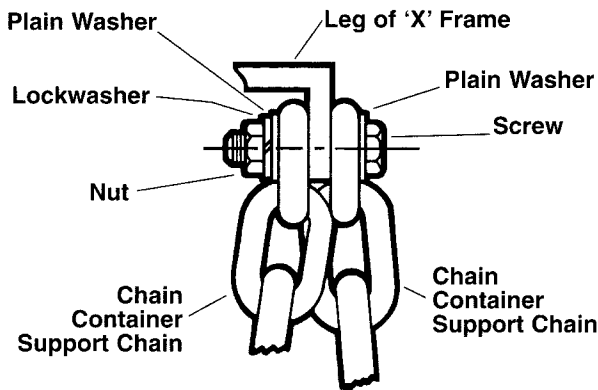

Figure 1. Support Chain Attachment

After the chain container is installed, use the instructions in Manual Number 670 to reset the upper limit switch so that the uppermost point of the hook travel is just below the bottom of the chain container.

Under no condition should the hook or load be permitted to come in contact with the chain container. If this occurs, the chain container may be damaged. The function of the chain container may be interfered with and/or the support bracket and fasteners may be imperiled.

NOTE: On units with very long lifts auxiliary supports may be provided for the chain container. For such units, separate installation instructions will be provided.

OPERATION

Refer to Manual Number 670 for information and safety procedures.

MAINTENANCE

Refer to Manual Number 670 for information on frequent and periodic inspections. The periodic inspections on the 3 and 4-part single reeved units should also include items in Table 2.

Hooks

The 3 and 4-part single reeved units are equipped with latch type hooks. Hooks damaged from chemicals, overloads, deformation or cracks, or that have a 10 degree twist from the plane of the unbent hook, or excessive throat opening, or excessive seat wear, must be replaced. Also, hooks that are opened and allow the latch to disengage the tip, must be replaced.

Any hook that is twisted or has excessive throat opening indicates abuse or overloading of unit. Other load sustaining components of the hoist should be inspected for damage and replaced if the hook shows evidence of any of the above.

Check to ensure the latch is not damaged or bent and that it operates properly. Depress the latch and release to make sure the it springs back to engage the tip and close throat opening. If it does not spring back, replace the latch and spring.

The information in Figure 2 should be used to determine when the hook must be replaced. Remove the latch to measure the opening. be sure to replace the latch after measurements are completed.

Latch Type Hook:

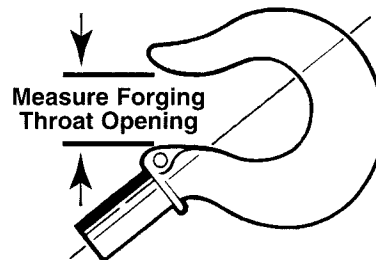

Hook Throat Openings

Hoist Capacity (Tons)	Opening (In.) Replace Hook When Opening Is Greater Than:
7 1/2	2-7/8
9, 10, 12	3-7/8

Figure 2. Latch Hook Opening

Table 2 Minimum Periodic Inspections

TYPE OF SERVICE			ITEM
Norman	Heavy	Severe	
↑ Yearly ↓	↑ Every 6 Months ↓	↑ Every 3 Months ↓	<ol style="list-style-type: none"> 1. Check snubber block(670-235) for wear or damage. Replace snubber block if worn or damaged. 2. Inspect chain guide area of idler wheel hanger (670-227) for wear. Replace idler wheel hanger if severely worn. 3. Dead end pin (670-449) and clevis portion of chain hanger (670-152) for wear. Replace worn or damaged parts.

Load chain Removal & Installation

In general, follow the instructions in Manual Number 670. However, it is recommended that when only load chain is to be replaced, method 1 be used. To use this method, energize the hoist in the down direction until the lower limit switch stops the downward motion. Remove the chain container from the hoist. Remove the shroud access cover and **disengage** the limit switch guide plate from the traveling nuts.

On the 3-part single reeved units, attach the coupling link to the loose end of the chain. The coupling link should be an upstanding link. Attach the new chain to the old chain so that the first link of the new chain is a flat link, and the upstanding links of the new chain have the welds away from the liftwheel. Remove the dead end pin from the hook block and remove the snubber block. Energize the hoist in the down direction to feed the new chain up around the liftwheel, down around the hook block sheave, up around the idler hanger sheave and down to the hook block.

Continue to operate the hoist in the down direction until there are 8 to 12 links of new chain hanging free from the bottom of the chute. Remove the coupling link and attach the new chain to the hook block using the dead end pin, making sure there are no twists in the chain between the idler wheel hanger and the hook block. Re-install the snubber block, attach the chain container to the bottom of the hoist and **re-adjust** the limit switches.

On the 4-part single reeved units, attach the coupling link to the loose end of the chain. The coupling link should be a flat link. Attach the new chain to the old chain so that the first link of the new chain is an upstanding link with the welds of all upstanding links away from the liftwheel. Remove the snubber block. Remove the dead end pin from the dead end hanger assembly to release the spring container. Disassemble the spring container and disengage the dead end of the old chain from the half link. Energize the hoist in the down direction to feed the new chain up around the liftwheel, down around the first hook block sheave, up around the idler hanger sheave and down around the second hook block sheave. When one or two feet of new chain has exited from the second hook block sheave, stop the hoist. Install the half link in the dead end of the new chain and then assemble these into the spring container.

Energize hoist in the down direction until there are 8 to 12 links of new chain hanging free from the bottom of the chute. Attach the spring container to the dead end hanger assembly using the dead end pin, making sure there are no twists in the chain between the hook block and the spring container. Reinstall the snubber block, attach the chain container to the bottom of the hoist and **re-adjust** the limit switches.

NOTE: For reeving of the chain, refer to the parts list drawings included in this supplement.

Protector

On the 3 and 4-part single reeved units the Protector is adjusted so that the hoist will refuse to lift approximately 125% of its rated capacity. If the periodic inspections indicate that the Protector is slipping at other than 125% rate of capacity, it should be adjusted as described in Manual Number 670 but using the following slip points in Table 3.

Hoist Capacity (Tons)	Slip Point of Protector (Pounds)
7½	18,750
9	22,500
10	25,000
12	30,000

CAUTION: The Protector must not, under any circumstances, be at set values beyond those specified, or used at any set value as a scaling device.

Adjustable Screw Limit Switch

The adjustable screw limit switch is not to be used as a normal means of stopping the hoist.

The 3 and 4-part single reeved hoists are equipped with a double reduction type adjustable screw limit switch. As such, the maximum lift and hook travel per notch on the standard units shown in Table 4.

Table 4. Screw Limit Switch

Reeving	Length of Max. Lift (Feet)	Hook Travel Per Notch (In.)
3 part, single 4 part, single	42'-4" 31'-9"	0.67 0.50

NOTE: Longer lifts are obtainable by using a special limit switch gearing from the factory on a special basis.

For proper operation, the upper screw limit switch should be adjusted to stop the hoist when the top of the snubber block is in line with the bottom of the chain container. The lower screw limit switch should be adjusted to stop the hoist when from 8 to 12 chain links are remaining between the loose end link and the bottom of the chute.

Trouble Shooting & Electrical Data

Refer to Manual Number 670 for trouble shooting, electrical data and wiring diagrams.

REPLACEMENTS PARTS LIST

Manual Number 670 contains exploded views and parts lists for the basic hoist and trolleys. This supplement provides drawings and parts lists for the 3 and 4-part single reeved units. When ordering repair parts, use the parts lists and drawings in this supplement. If a particular part is not listed in the supplement, then order a part by using the exploded views and parts lists in Manual Number 670. Since many parts are not directly interchangeable, always specify the capacity, lift, serial number and power supply of the hoist and/or trolley for which the repair part is required.

The parts list appears on the back cover.

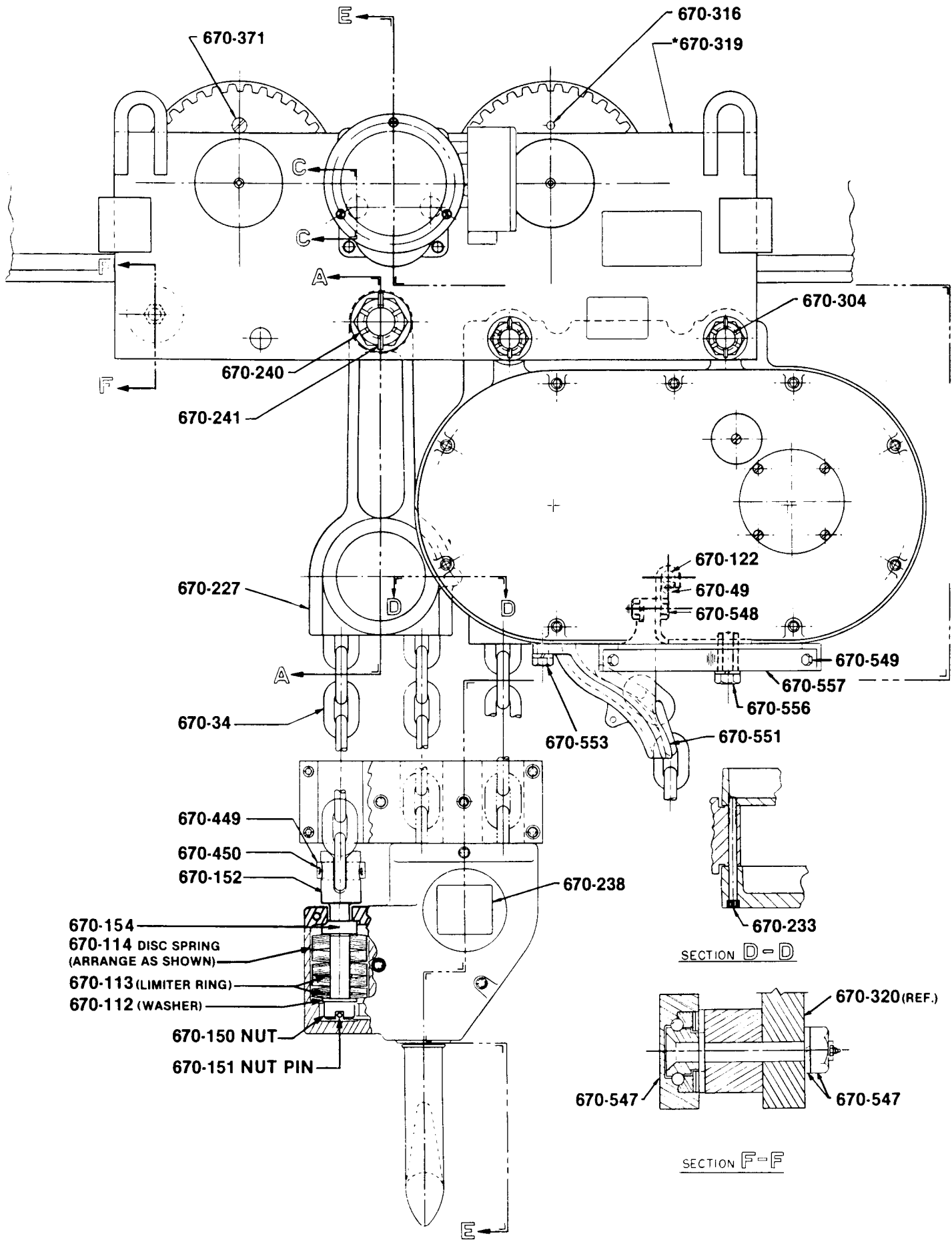

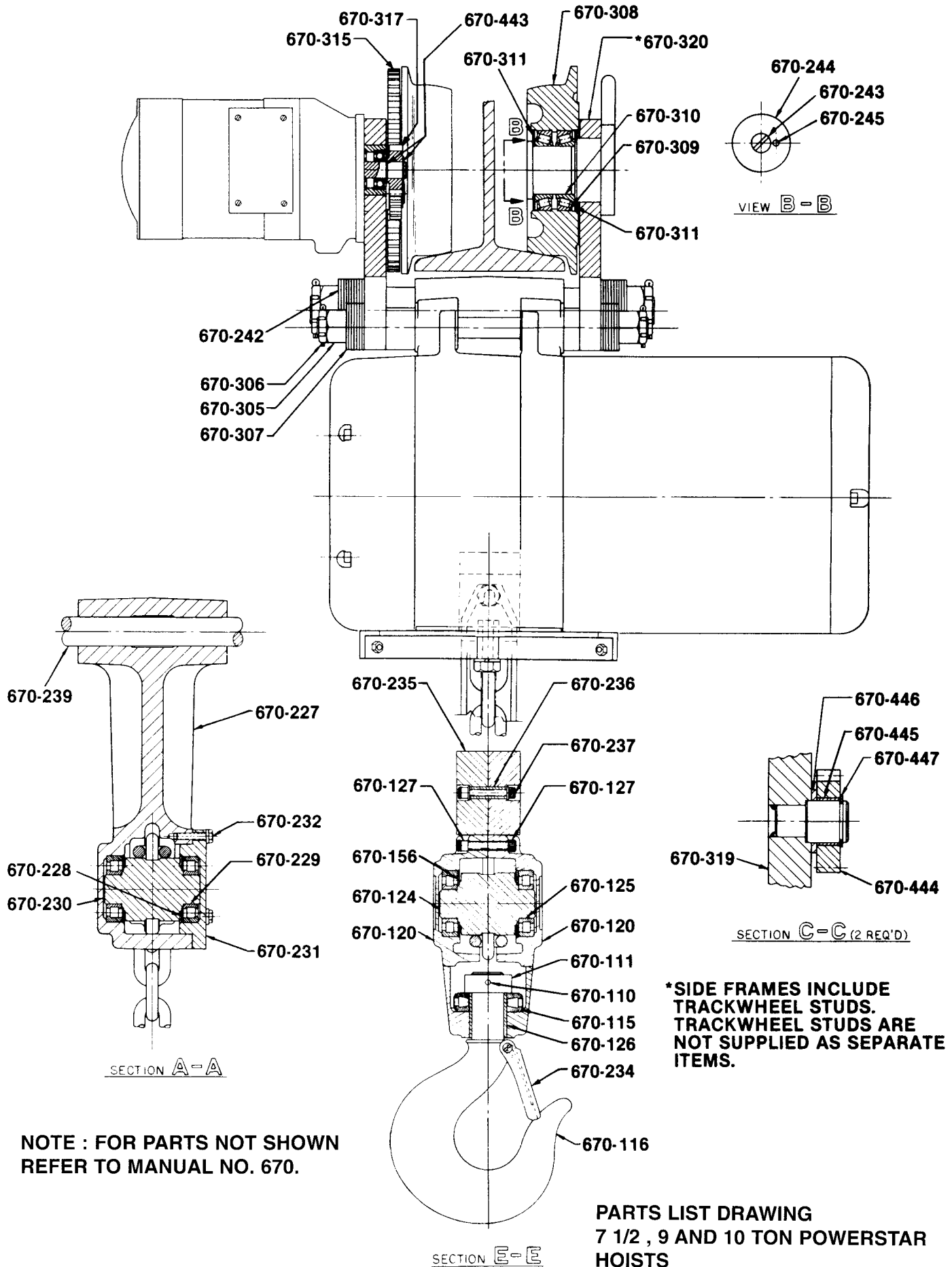

NOTE : FOR PARTS NOT SHOWN
REFER TO MANUAL NO. 670.

*SIDE FRAMES INCLUDE
TRACKWHEEL STUDS.
TRACKWHEEL STUDS ARE
NOT SUPPLIED AS SEPARATE
ITEMS.

PARTS LIST DRAWING
7 1/2 , 9 AND 10 TON POWERSTAR
HOISTS
3 PART SINGLE REEVED.

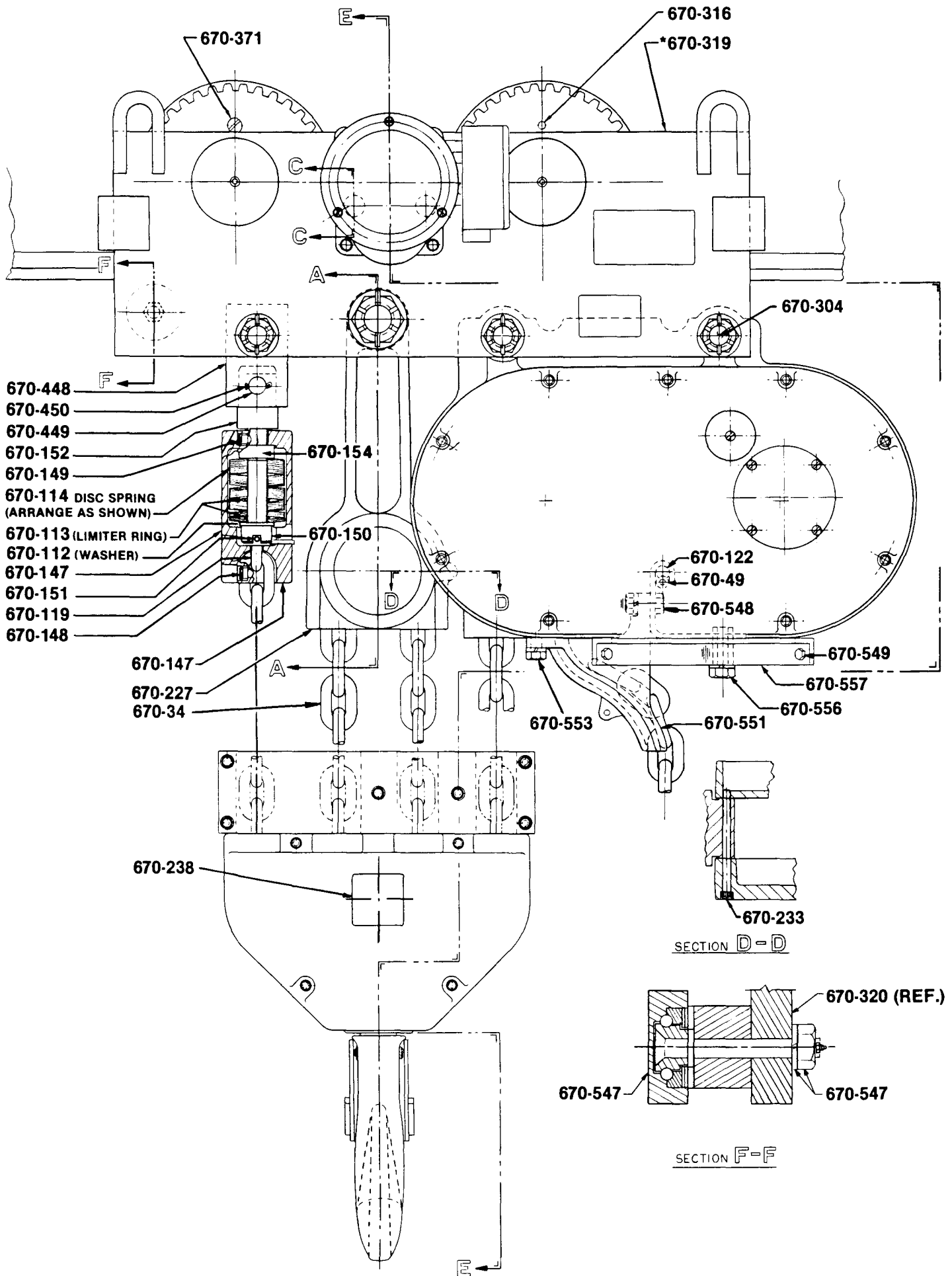

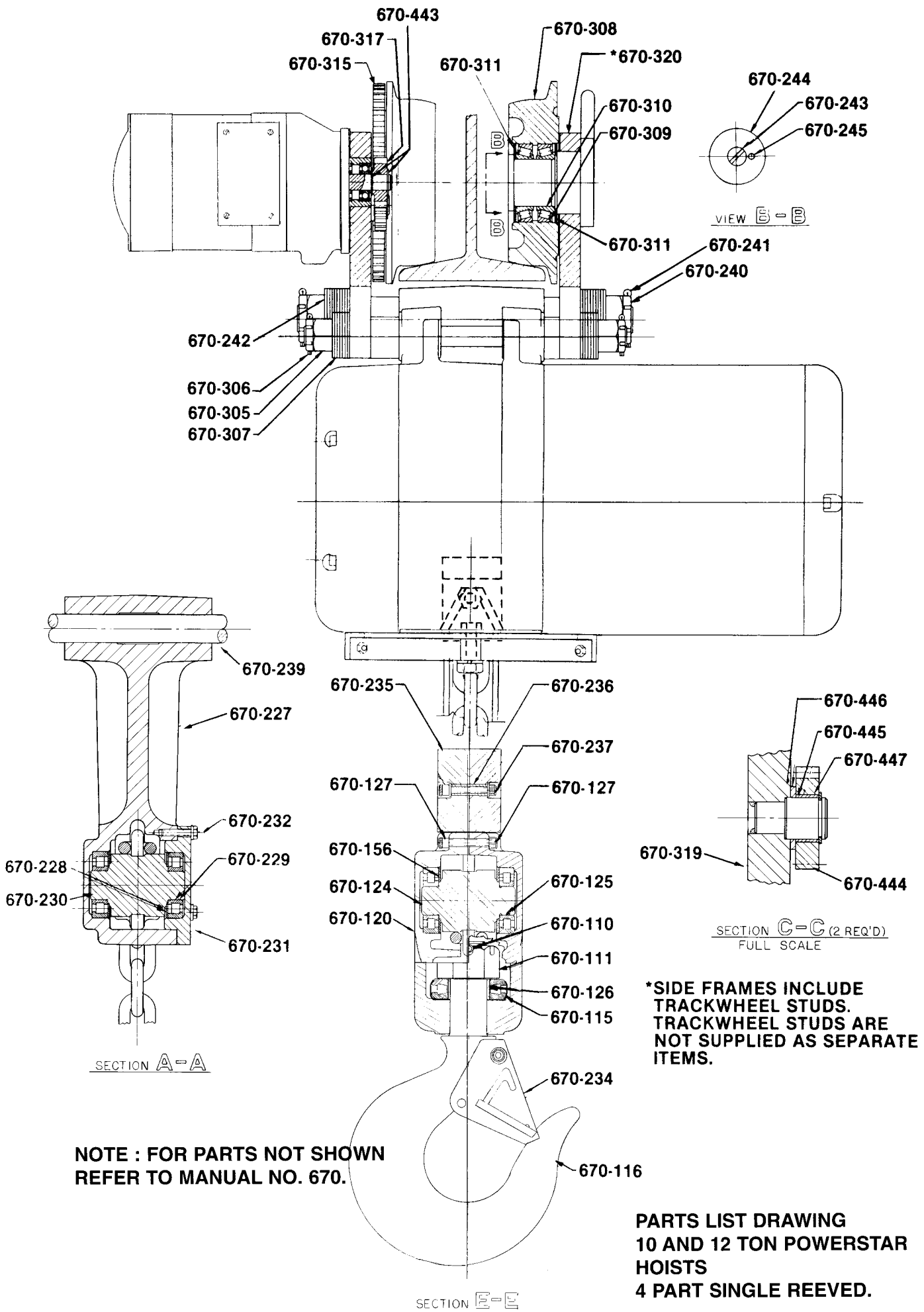

**NOTE : FOR PARTS NOT SHOWN
REFER TO MANUAL NO. 670.**

***SIDE FRAMES INCLUDE
TRACKWHEEL STUDS.
TRACKWHEEL STUDS ARE
NOT SUPPLIED AS SEPARATE
ITEMS.**

**PARTS LIST DRAWING
10 AND 12 TON POWERSTAR
HOISTS
4 PART SINGLE REEVED.**

*PART LIST		
Key No.	Part Name	No. Req'd
670-124	Hook block sheave (1 req'd on 3 part reeved, 2 req'd on 4-part reeved)	-
670-125	Hook block sheave bearing (2 req'd on 3-part reeved, 4 req'd on 4 part reeved)	-
670-127	Hook Block screw and nut	4
670-156	Bearing Shield (2 req'd on 3 part reeved; 4 req'd on 4-part reeved)	-
670-227	Idler wheel hanger	1
670-228	Bearing shield (idler wheel hanger)	2
670-229	Bearing (idler wheel hanger)	2
670-230	Sheave (idler wheel hanger)	1
670-231	Bearing cap (idler wheel hanger)	1
670-232	Bearing cap screw with lockwasher	3
670-233	Hanger attaching screw	1
670-234	Latch kit	1
670-235	Snubber block	2
670-236	Snubber block spacer	6
670-237	Snubber block hardware kit	6
670-238	Hook block capacity insert	2
670-239	Suspension bolt (Idler wheel hanger)	1
670-240	Suspension bolt nut (Idler wheel hanger)	2
670-241	Suspension bolt cotter pin (Idler wheel hanger)	2
670-242	Spacer Washer (specify no. req'd)	-
670-243	Trackwheel clamp screw	4
670-244	Trackwheel clamp screw washer	4
670-245	Trackwheel clamp screw washer pin	4
670-371	Trackwheel screw	4
670-443	Trackwheel pinion shaft snap ring	2
670-444	Idler pinion	2
670-445	Idler bushing	2
670-446	Thrust bushing	2
670-447	Idler pinion retaining ring	2
670-448	Dead end hanger assembly	1
670-449	Dead end pin	1
670-450	Dead end pin cotter pin	2
670-547	Anti-tipping wheel with nut and lockwasher	1
670-548	Chute mounting screw, lockwasher and nut	1
670-549	Chain container screw, washers, lockwasher and nut	4
670-556	Bracket mounting screw, washer and lockwashers	1
670-557	Bracket	1

*For parts not listed, see Manual Number 670.