

## Budgit Electric Hoists



<b>Capacities</b>	1/4 to 3 tons
<b>Lift</b>	10 foot, longer lifts available
<b>Lift speeds</b>	5 to 64 FPM
<b>AC Power</b>	115/230 1-60HZ; Reconnectable; 230/460 3-60; Reconnectable 208 and 575 3-60 single voltage
<b>Control</b>	Push button control voltages of 115 volts standard on all 3 phase models, single speed, two speed and single phase models. 24 volt control optional
<b>Suspension</b>	Hook, lug, plain, geared and motorized trolleys
<b>Options</b>	Load brake, weather proofing & waterproof covers, corrosion resistant, plating service, explo- sion proof div. 2, food service, spark resistant

### What's **NEW** with **BUDGIT** Electric Hoists



NEW Limit Switch



NEW Motor Brake

- ~~All hoists are provided with a high tech electronic upper & lower limit switch, easily adjustable by the press of a button.~~ **This is now an option not standard**
- New heavy duty motor brake is an AC spring set disc brake for positive braking action and long life with minimal maintenance. Easy 1-step adjustment procedure. **Now includes poly rather than mesh**
- ~~Nylon mesh fabric chain container included as standard for lifts up to 20'~~
- New design allows easy change out of either hook or lug suspension.
- Powdercoat finish

**There's a **BUDGIT** Hoist Solution for Every job**

# Budgit Electric Hoists

## Hook Mounted Hoists

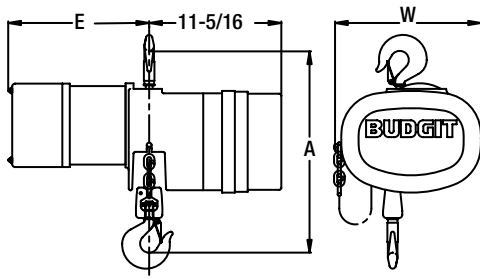

## Lug Mounted Hoist with push Trolley

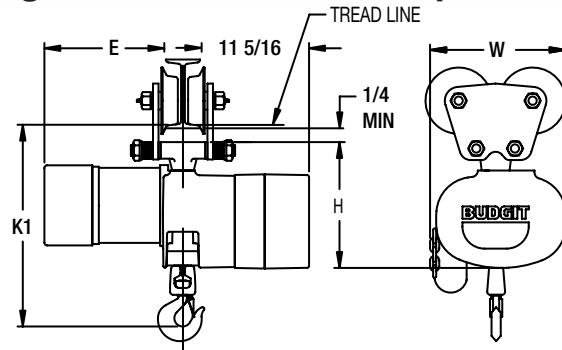

## Lug Mounted Hoists with Motor-Driven Trolley

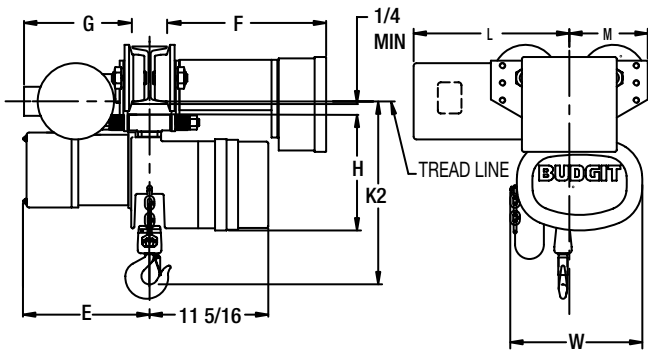

1/4 to 2 Ton

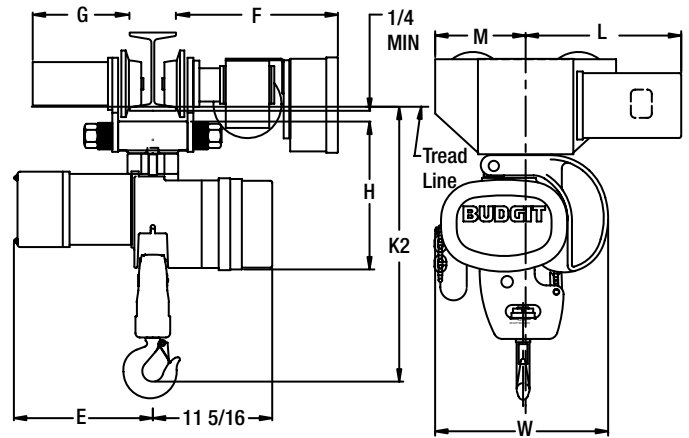

3 Ton

Capacity	Lift Speed	Motor	Parts of Chain	Hoist Catalog Number	Headroom (in)			H	W	E** Max.	F Max.	G Max.	L Max.	M Max.
					A	K1	K2							
tons	FPM	H.P.			in	in	in	in	in	in	in	in	in	in
1/4	16	1/4*	1	BEHC2516	16-3/4	16-13/16	17	10-3/16	11-7/16	12-1/4	16-13/16	12-3/8	10-3/16	8-9/16
	32	1/2		BEHC2532										
	64	1		BEHC2564										
1/2	16	1/2	1	BEHC5016	16-3/4	16-13/16	17	10-3/16	11-7/16	12-1/4	16-13/16	12-3/8	16-13/16	8-9/16
	32	1		BEHC5032										
1	8	1/2	1	BEHC0108	17-1/2	17-3/8	17-3/8	10-3/16	11-7/16	14-3/16	16-13/16	12-3/8	16-13/16	8-9/16
	16	1		BEHC0116										
	32	2-1/2		BEHC0132										
2	4	1/2	2	BEHC0204	23	22-1/16	22-1/4	11-1/8	11-7/16	14-3/16	16-7/8	10-1/4	16-3/4	9-5/16
	8	1		BEHC0208										
	16	2-1/2		BEHC0216										
3	5	1	3	BEHC0305	25-7/8	26-3/8	25-9/16	12-7/8	15	14-3/16	16-9/16	8-1/2	17-3/4	9-9/16
	10	2-1/2		BEHC0310										

\*Two speed hoist has a 1/2 H.P. motor

\*\* "E" Dimensions listed represent maximum length between one and two speed model hoists. Consult factory for exact dimensions.

There's a **BUDGIT Hoist** Solution for Every job



Lift-Tech International  
 414 West Broadway Ave • P.O. Box 729  
 Muskegon, MI 49443-0769  
 Phone 800-742-9269 • Fax 800-742-9270  
 www.budgithoists.com

**BUDGIT**<sup>®</sup>  
**Hoists**

BHF-BEH1206