



Operation, Service & Parts Manuals

This owners manual also applies to the following
hoists: CM AirStar, Coffing CAH, and Yale YAL

BUDGIT® SERIES 2200 AIR HOIST

**FOR USE WITH MODEL
115325**

FOREWORD

This book contains important information to help you install, operate and maintain your new **BUDGIT** Air Hoist. We recommend that you study its contents thoroughly before putting your hoist to use. Through proper installation, application of correct operating procedures, and by practicing the recommended maintenance suggestions you will be assured maximum service from your hoist.

Complete inspection, maintenance and overhaul service is available for **BUDGIT** Air Hoists at authorized **BUDGIT** Repair Stations. Refer to your telephone directory yellow pages under "HOISTS." They are staffed by qualified factory-trained

servicemen and stock approved **BUDGIT** replacement parts.

Replacement parts information is also included in this book for your convenience. Since it will likely be a long time before parts information is needed, we suggest that, after you have become familiar with operation and preventive maintenance procedures, this book be carefully filed for future reference.

EQUIPMENT ILLUSTRATED AND DESCRIBED HEREIN IS NOT DESIGNED OR SUITABLE FOR LIFTING OR LOWERING PERSONS.

INDEX

SECTION I	GENERAL DESCRIPTION	PAGE
Paragraph	1-1 General	3
Paragraph	1-2 Basic Construction	3
Paragraph	1-3 Differences Between Models and Sizes	3
Paragraph	1-4 Hoist Data	3
SECTION II	INSTALLATION	
Paragraph	2-1 General	4
Paragraph	2-2 Suspending Hoist	4
Paragraph	2-3 Connecting Hoist to Air Service	4
Paragraph	2-4 Hoisting and Lowering Speed Adjustments	5
SECTION III	OPERATION	
Paragraph	3-1 General	5
Paragraph	3-2 Pre-Operational Checks	5
Paragraph	3-3 Operating Hoist	5
Paragraph	3-4 Pulling and Pivoting Hoist and Load	6
Paragraph	3-5 Upper and Lower Limit Stops	6
Paragraph	3-6 Operating Precautions	6
SECTION IV	LUBRICATION	
Paragraph	4-1 General	7
Paragraph	4-2 Service Air Line Lubricator	7
Paragraph	4-3 Gearcase	7
Paragraph	4-4 Lubricate Load Chain	7
Paragraph	4-5 Lubricate Upper Hook and Lower Block Assembly	7
Paragraph	4-6 Lubricate Control Shaft, Brake Cam and Valve Shifter	7
Paragraph	4-7 Lubricate Trolley Wheel Bearings	7
SECTION V	MAINTENANCE	
Paragraph	5-1 General	7
Paragraph	5-2 Thirty-Day Inspection	7
Paragraph	5-3 Annual Inspection	9
SECTION VI	TROUBLE SHOOTING	10
SECTION VII	DISASSEMBLY AND REASSEMBLY	
Paragraph	7-1 General	11
Paragraph	7-2 Disassembly	11
Paragraph	7-3 Cleaning and Inspection	14
Paragraph	7-4 Reassembly	14
Paragraph	7-5 Testing Hoist	16
Paragraph	7-6 Pendant Throttle Control Assembly	17
SECTION VIII	PARTS LIST	
Paragraph	8-1 Introduction	17
Paragraph	8-2 Parts List	17
Figure	8-1 Frame and External Parts (Coil Chain)	18
Figure	8-2 Frame and External Parts (Roller Chain)	20
Figure	8-3 Gearing, Sprocket and Load Brake Parts	22
Figure	8-4 Control Head Parts	23
Figure	8-5 Air Motor Parts	24
Figure	8-6 Control Cylinder and Pendant Throttle Parts	25
Figure	8-7 Special Parts Table - Spark Resistant Models	26

Notice: Information contained in this book is subject to change without notice.

SECTION I - GENERAL DESCRIPTION

1-1. GENERAL. BUDGIT Air Hoists are precision built chain type hoists which are built in three rated loads, 1/4, 1/2, and 1 ton. Each size is available in pull cord control and pendant throttle control models. In addition, there are model variations with coil type or roller type load chains and hook or lug type suspensions. Coil chain hoists are also provided in spark resistant models. (Note: Spark resistant models have rated loads of 3/8 and 3/4 ton.)

1-2. BASIC CONSTRUCTION. All sizes and models are of the same basic design, having many common and interchangeable parts. They consist primarily of an aluminum alloy frame which houses a vane type air motor, chain sprocket wheel, and gearing. A shoe-type brake is mounted on one end of frame and is encased in an aluminum alloy end cover. A control head assembly with built-in muffler and air inlet swivel connection is mounted on opposite end of frame. An upper suspension hook or lug bracket is attached to the top of the frame. Either a special nickel steel roller type load chain or an alloy steel coil type load chain with spring-latch type lower block assembly is employed to raise and lower loads. A block and chain operated limit stop lever is mounted at bottom of frame and is pinned to throttle valve control shaft. Hoist operation is controlled by either pull cords or a pendant throttle control assembly.

1-3. DIFFERENCES BETWEEN MODELS AND SIZES. The main differences between hoist models are in the type of control, type load chain and type suspension employed. These are described in paragraphs (a.) through (c.) below. Differences between sizes are in reeving of the load chain. On 1/4 and 1/2 ton hoists, the load chain is single reeved (one part of chain); on 1 ton hoists, the chain is double reeved (two parts of chain).

Standard lift is 10' though increased lifts may be ordered.

a. Control differences are in methods employed for operating hoist. There are two types, pull cord control and pendant throttle control. These are further described in Section III, paragraphs 3-1 and 3-3.

b. Two types of load chains are used as the lifting medium, roller chain and coil chain. The roller type chain is a special precision manufactured nickel steel chain. The coil type chain is full-flexing, electric welded, link chain; carburized alloy steel on standard models and surface hardened chrome-nickel stainless steel on spark resistant models. Both types are especially designed for use in hoisting.

c. Suspension differences include a conventional hook type mounting and a lug type mounting. Hook suspension allows portability, permitting hoist to be easily moved from job to job. Lug suspension allows rigid trolley mounting of hoist on an overhead I-beam to permit traversing hoist and load. Rigid mounting of trolley on hoist affords maximum headroom advantage, saving up to 3-3/16" compared to a hoist hook-suspended on a trolley.

1-4. HOIST DATA.

*Rated Loads: 1/4, 1/2 and 1 ton
Air Pressure (recommended): 90 psi
Air Consumption: 48 cfm at 90 psi
Net Weight (basic hoist): 36 pounds
Suspension: Hook or lug
Control: Pull Cord or Pendant Throttle

*For standard models. Spark resistant models are rated at 3/8 and 3/4 ton.



Figure 1-1. Views of Various Air Hoist Models

SECTION II - INSTALLATION

2-1. GENERAL. BUDGIT Air Hoists are completely lubricated and load tested before being shipped from the factory. To place hoist in service, attach to a suitable overhead suspension (Paragraph 2-2) in area to be used; connect hoist to nearest air supply (paragraph 2-3); and check and adjust hoist speed (paragraph 2-4).

2-2. SUSPENDING HOIST.

a. On hook suspended hoists, select a suitable overhead support in area hoist is to be used (one capable of holding combined weight of hoist and its rated load) and hang hoist up. **Be certain that upper hook is firmly seated in center of hook saddle and that the spring safety latch is properly closed over hook opening.** In some cases, it may be necessary to first remove spring latch before hook will fit over a support. Reinstall latch after hook is engaged.

b. On lug suspended hoists, select a suitable overhead support in area hoist is to be used (one capable of holding combined weight of hoist and its rated load). Mount hoist using through bolts of appropriate size to fit mounting holes in suspension lug at top of hoist. Use only suspension bolts provided by Yale•Lift-Tech. (See table below.)

⚠ CAUTION

The structure used to suspend hoist must be of sufficient strength to withstand reasonable forces to which hoist and support may be subjected. Hoist must be aligned with load to avoid side pulls.

SUSPENSION LUG BOLT SIZE AND HOLE SPACING

Dimension (in)	Hoist Rated Load (ton)	
	1/4, 3/8 & 1/2	3/4 & 1
Bolt Size	5/8	5/8
Center Distance Between Bolt Holes	3-1/8	3-1/8
Suspension Lug Widths	3-5/8	4

c. On rigid mount trolley suspended hoists, the trolley side plates must be properly spaced so trolley will fit (beam on which hoist will operate). Adjustment for various I-beam sizes is accomplished by rearrangement of spacer washers on through bolts which connect trolley side plates to hoist suspension lug. Refer to instruction sheet furnished with **BUDGIT** Rigid Mount Trolleys for complete instructions.

⚠ WARNING

If trolley is mounted on an open-end beam, end stops must be installed to prevent trolley from running off the end of the beam resulting in injury to operator and other and damages to load and other property.

d. If chain container is to be used on hoist, install it following instructions furnished with container.

2-3. CONNECTING HOIST TO AIR SERVICE.

a. Connect hoist to nearest filtered and lubricated air source using minimum 1/2" I.D. air hose assembly (see Figure 2-1). Avoid use of reducing bushing and nipple or hose assemblies of smaller diameters which may cause restrictions.

b. If hoist is suspended by trolley, provide sufficient hose to reach from air source to farthest point of trolley travel. **BUDGIT** Hose Trolleys are recommended to keep hose up out of the way (see Figure 2-2).

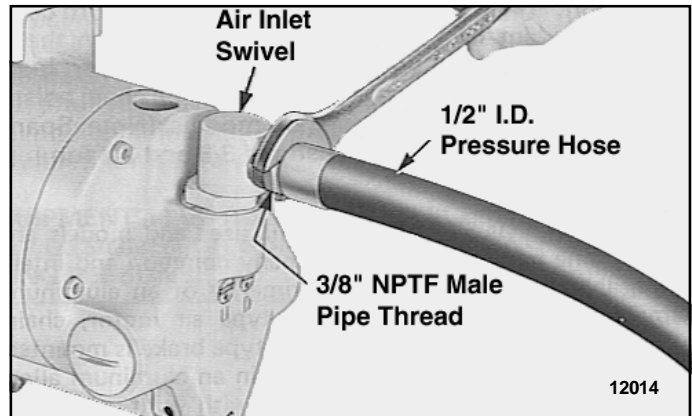

Figure 2-1. Connecting Air Hose to Hoist.

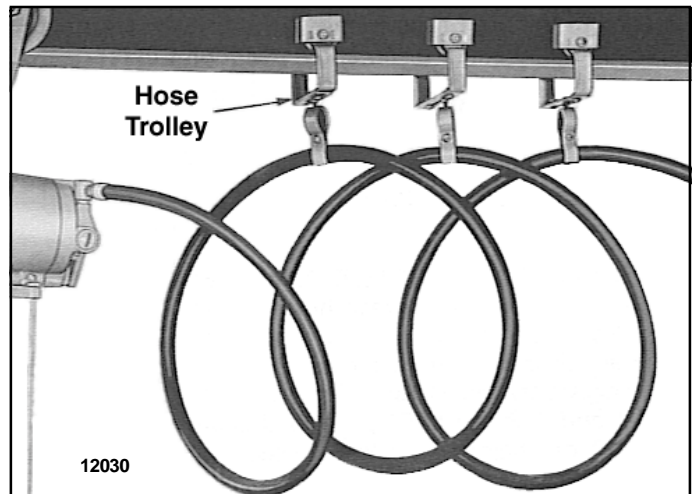

Figure 2-2. Air Hoist Supported by **BUDGIT** Hoist Trolleys.

c. A filter and lubricator unit (Figure 2-3) must be installed between air source and air hose leading to hoist. These keep air flowing to hoist free of dirt and add lubricant to air so internal parts of motor are constantly lubricated. Use Air Hoist Motor Oil or good grade IOW machine oil (approximately viscosity 150 SSU at 100°F.) Multi-viscosity, detergent type engine oil is not recommended. Feed one drop of oil for every 50 to 75 cubic feet of air going through the air motor.

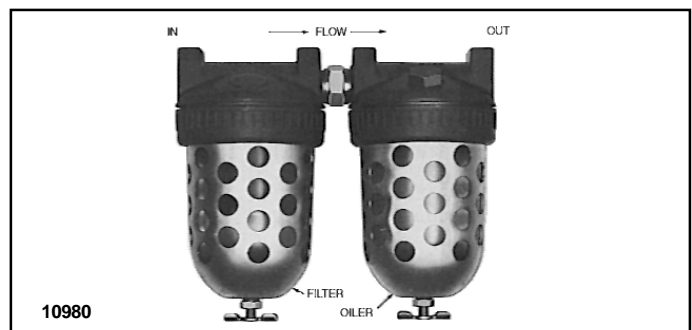

Figure 2-3. Air Filter and Lubricator Unit.

d. The recommended operating air pressure for all capacities of **BUDGIT** Air Hoists is 90 psi. When line pressure exceeds

100 psi (while hoist is operating), it is recommended that a pressure regulator valve be provided in the air supply line to maintain proper pressure. However, there is a wide range of pressures within which the hoists will operate. Refer to "Performance Charts." See Figure 2-5.

2-4. HOISTING AND LOWERING SPEED ADJUSTMENTS.

a. Hoist speed is adjusted at the factory to give maximum lifting speed and is set at average between minimum and maximum lowering speed.

b. To adjust the hoisting or lowering speed, turn appropriate regulator screw (Figure 2-4) in either direction a little at a time while operating hoist under load.

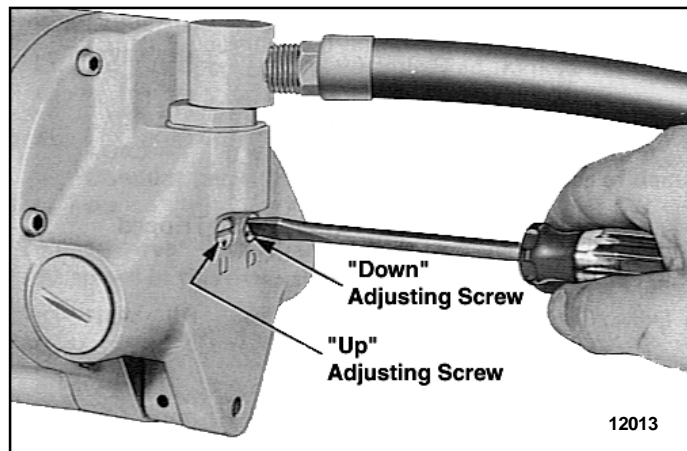

Figure 2-4. Hoisting and Lowering Speed Adjustment.

CAUTION

Maximum lowering speed with rated load is very high. Adjust with care. Heads of adjusting screws should not extend beyond outer surface of housing.

c. When the screwdriver slots on ends of adjusting screws are horizontal (hoist in normal suspended position), the hoist speeds will be at either minimum speed or maximum speed. Rotating the screws 180° in either direction will give a full adjustment between minimum and maximum speed limits. **Note:** Screws have arrow stamped on end to assist operator with adjustment.

1/4 TON RATED LOAD HOIST

Load	125 lbs.		250 lbs.		500 lbs.							
	Up	Down	Up	Down	Up	Down						
	Min.	Max.	Min.	Max.	Min.	Max.						
0	0	0	5	8	0	0	15	40	0	0	25	65
60	35	70	30	75	30	65	35	85	20	50	40	95
70	40	75	30	80	35	70	35	85	25	60	40	95
80	40	80	35	80	35	75	35	85	30	60	40	95
90	40	80	35	80	35	80	35	85	30	65	40	95
100	40	80	35	80	40	80	35	85	30	65	40	95

1/2 TON RATED LOAD HOIST

Load	250 lbs.		500 lbs.		1000 lbs.							
	Min.	Max.	Min.	Max.	Min.	Max.						
0	0	0	15	40	0	0	25	65	0	0	45	125
60	30	65	35	85	20	50	40	95	0	20	45	125
70	35	70	35	85	25	60	40	95	0	30	50	120
80	35	75	35	85	30	60	40	95	10	40	55	120
90	35	80	35	85	30	65	40	95	15	45	55	120
100	40	80	35	85	30	65	40	95	20	50	55	120

1 TON RATED LOAD HOIST

Load	500 lbs.		1000 lbs.		2000 lbs.							
	Min.	Max.	Min.	Max.	Min.	Max.						
0	0	0	8	20	0	0	13	33	0	0	25	65
60	15	32	16	42	10	25	20	50	0	10	25	65
70	16	35	17	42	12	30	20	50	0	15	25	60
80	17	37	18	42	14	31	20	48	5	20	30	60
90	18	40	18	42	15	32	20	47	7	23	30	60
100	20	40	18	42	15	34	20	45	10	25	30	60

Note: Hoist Speeds are shown in feet per minute (f.p.m.)

Figure 2-5. Hoist Performance Charts.

SECTION III - OPERATION

3-1. GENERAL. Operation of BUDGIT Air Hoists is controlled by either pull cords or a pendant throttle control, depending upon the model. Pull Cord Control models have pull type control cords (Figure 3-1) suspended from a rocker type lever at bottom of hoist that actuates the throttle control valve. Pendant Throttle Control models have a convenient lever type control valve handle (Figure 3-2) suspended from the control cylinders on sides of control head housing.

WARNING

Do not lift more than rated load except for test purposes. Overloading hoist can result in chain breakage, hook deformation and other failures which can cause serious injury and damage. A test at greater than rated load should be a properly supervised official test only, not an operator test. If any load sustaining parts have been altered, replaced or repaired, hoist should be load tested at 125% of rated load by a designated, qualified person, with a written report recording test load, as recommended in ANSI B30.16 Safety Standards.

3-2. PREOPERATIONAL CHECKS. Check the following before operating hoist with load:

a. Inspect chain anchor connections at side of hoist frame and at upper hook or lug mounting bracket on 3/4 and 1 ton double reeved models. Anchor screw or pin should be secure and not bent or broken. Chain should be solidly anchored.

b. Check hoist brake for proper adjustment and operation. Refer to Section V, paragraph 5-2, d.

c. Check hooks. They should not be bent or distorted and should not be opened beyond the correct opening sizes given in Figure 5-3. Hook latches should not be bent or damaged and springs not broken.

d. Check chain to make sure it is not twisted or kinked. Be sure lower block (3/4 and 1 ton, double reeved models) has not been capsized.

WARNING

Never operate hoist with defective chain anchor pins, brake or hooks.

e. Lubricate chain per paragraph 4-4.

3-3. OPERATING HOIST. With hoist installed and air pressure

turned on, hoist is operated in the following manner:

a. Pull Cord Control.

- (1) Pull top handle (marked with arrow pointing up) down to raise load.
- (2) Pull bottom handle (marked with arrow pointing down) down to lower load.
- (3) Release handle being used to stop either lifting or lowering.
- (4) Speed of lifting and lowering is varied between slowest (inching) to full speed by the pull exerted on control handle being used.

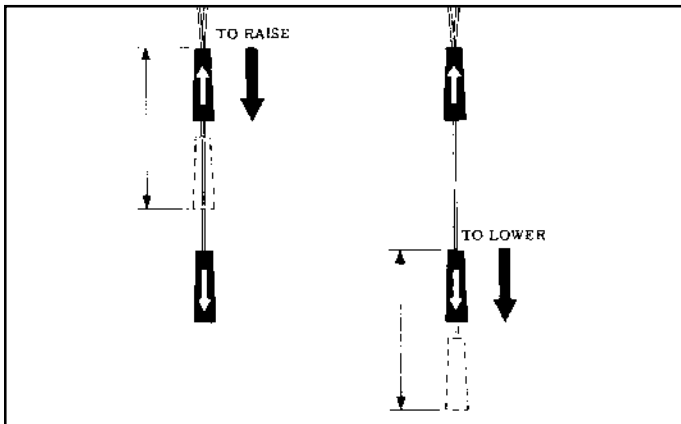

Figure 3-1. Pull Cord Control Handles.

load, thus reducing side thrust.

3-5. UPPER AND LOWER LIMIT STOPS. A lower block and chain operated limit stop is provided to guard against over travel of load in either raising or lowering direction, which can cause damage to hoist. When highest position is reached, the lower block trips the control lever (Figure 3-3). When lowest position is reached, the tail end of load chain trips the control lever (Figure 3-4). The control lever is connected to the control shaft which actuates inlet valves controlling air pressure to air motor. Limit stops are intended as safety devices and should not be used as a routine basis to stop travel of lower block or shut off hoist.

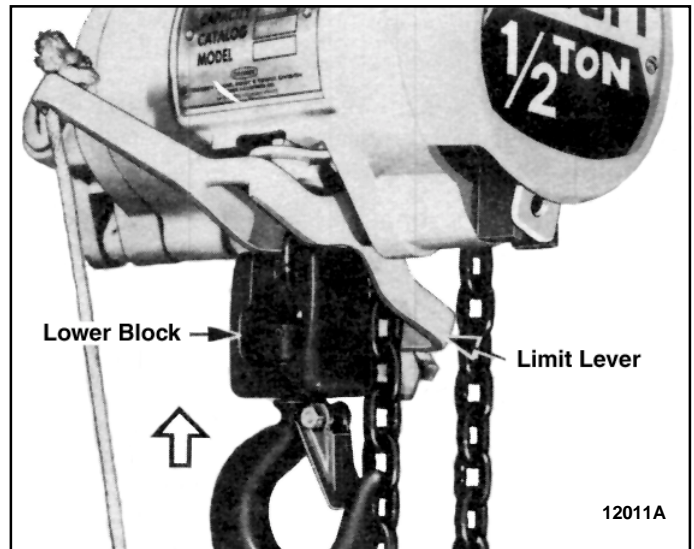

Figure 3-3. Control Lever Being Tripped by Lower Block.

b. Pendant Throttle Control.

- (1) Depress throttle valve lever marked "UP" to raise load. See Figure 3-2.
- (2) Depress throttle valve lever marked "DOWN" to lower load.
- (3) Release lever being depressed to stop either lifting or lowering.
- (4) Speed of lifting and lowering is varied by the position of the throttle valve lever being depressed.

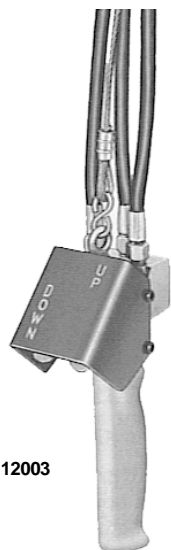

Figure 3-2. Pendant Throttle Control Handle

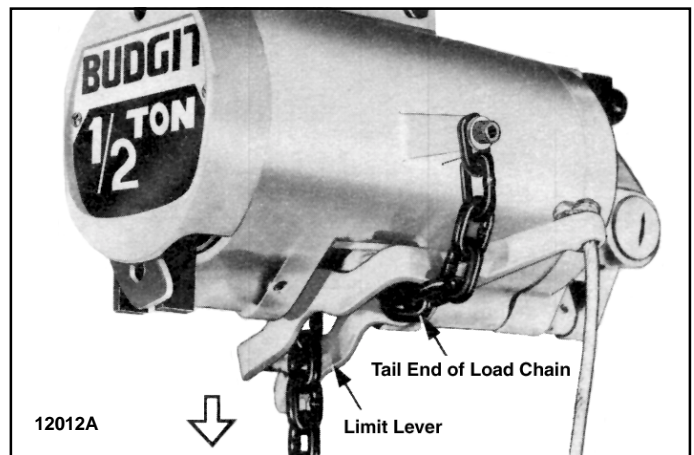

Figure 3-4. Control Lever being Tripped by Tail End of Load Chain.

3-4. PULLING AND PIVOTING HOIST AND LOAD.

a. On Pendant Throttle Control models, the valve handle is supported by a strain cable that is suitable for pulling trolley suspended hoists **when empty or lightly loaded**. Use a tag line or pole to pull or push loads to traverse heavily loaded hoists. Observe caution to stay clear of loads.

b. To pivot load, push on one corner of load. Lower hook will swivel through 360 to permit load to be swung to the desired position. The upper hook (hook suspension models) is also designed to rotate so that side pulls will swing hoist to face the

⚠ WARNING

Equipment covered herein is not designed or suitable as a power source for lifting or lowering persons.

Safe operation of an overhead hoist is the operator's responsibility. Listed below are some basic rules that can make an operator aware of dangerous practices to avoid and precautions to take for his own safety and the safety of others. Observance of these rules in addition to frequent examinations

and periodic inspection of the equipment may save injury to personnel and damage to equipment.

- a. Operate hoist cautiously to become familiar with its performance.
- b. Do not load hoist beyond rated load.
- c. Take up chain slack carefully to avoid jerking load.
- d. Never use hoist load chain as a sling.
- e. Always be sure there is no twist in coil load chain. On 3/4 and 1 ton hoists, check to see that lower block is not capsized between strands of chain.
- f. Check both upper and lower limit stop operation by raising or lowering empty hook to limit of travel. Hoist must shut off.
- g. When lifting load, make certain it is free to move and will clear all obstructions.
- h. Stand clear of all loads and never lift or travel loads over people.
- j. Avoid operating hoist when hook is not centered under hoist. Be sure that hoist trolley or other support mechanism is correctly positioned for handling the load before lifting.
- k. Guide load so as to have it under control at all times.
- l. Do not operate hoist with twisted, kinked or damaged chain.
- m. Do not operate damaged or malfunctioning hoist.
- n. Conduct periodic visual inspection for signs of damage or wear.
- o. Observe inspection and maintenance procedures described in this manual.
- p. Never lift or transport a load until all personnel are clear. Never lift people on hook or load.
- q. Do not divert attention from load while operating hoist. Never leave a suspended load unattended.
- r. Do not use limit stop as normal operating stop. This is a safety device only.
- s. Do not "jog" unnecessarily.
- t. Personnel not physically fit or properly qualified, shall not operate hoist.
- u. Do not remove or obscure warning labels.
- v. Use common sense and best judgement whenever operating a hoist. Observe American National Standard Safety Standard, ANSI B30.16 latest issue.

SECTION IV - LUBRICATION

4-1. GENERAL. The lubrication services outlined in paragraphs 4-2 through 4-7 should be performed at regular intervals to maintain top hoist performance and insure long life. Frequency of lubrications will depend on type of hoisting service hoist is subjected to and should coincide with preventive maintenance inspections. See Section V - Maintenance.

4-2. SERVICE AIR LINE LUBRICATOR. Servicing air line filter and lubricator unit is of primary importance since it is the only source of lubrication for control valves and air motor. Fill lubricator with Air Hoist Motor Oil or good grade 10W machine oil (approximate viscosity 150 SSU at 100°F.). Multi-viscosity, detergent type engine oil is not recommended.

4-3. GEARCASE. The gearcase is grease packed at the factory

and requires no further greasing unless the gearcase is for any reason disassembled. Then, at reassembly, the parts should be washed clean (using commercial fluid) and repacked with NLGI EP-2 Grease.

4-4. LUBRICATE LOAD CHAIN. A small amount of lubricant will greatly increase load chain life; therefore, chain should not be allowed to run dry. Chain should be cleaned and lubricated as directed in paragraphs a. and b. below, depending upon type of chain. User should set up a regular schedule for chain lubrication after observing operating conditions for a few days. Use Bar and chain Oil (LUBRIPLATE or equal) on load chain.

a. **Coil Chain.** Under ordinary conditions, only weekly attention will be necessary for alloy steel chain. Under hot and dirty conditions, it may be necessary to clean chain at least once a day and lubricate it several times between cleanings. Thoroughly clean chain with an oil solvent and relubricate by coating it lightly with penetrating oil and graphite. Make sure that lubricant coats wear surfaces between links.

Stainless steel load chain must be well lubricated at all times and must be inspected daily when in use.

b. **Roller Chain.** Under ordinary conditions, only monthly attention will be necessary. Under hot and dirty conditions, weekly attention may be required. Thoroughly clean chain with an oil solvent and apply a good grade of S.A.E. 20 motor oil. Wipe off excess oil. When subjected to excessive moisture or corrosive atmospheres, DO (dripless oil) lubricant from American Grease Stick Company is recommended for use on roller chain in place of regular motor oil.

4-5. LUBRICATE UPPER HOOK AND LOWER BLOCK ASSEMBLY.

a. On 3/4 and 1 ton hoists, apply a few drops of S.A.E. 60 oil on shank of upper hook where it enters suspension bracket.

b. On single line hoists (1/4, 3/8 and 1/2 ton) disassemble upper and lower hooks as described in 7-2.b.(4) and grease thrust bearings with a good grade of bearing grease.

c. On double line hoists (3/4 and 1 ton) lower blocks, disassemble as described in 7-2.b.(5) and grease needle bearings for sprocket shaft and hook with a good grade of bearing grease.

4-6. LUBRICATE CONTROL SHAFT, BRAKE CAM AND VALVE SHIFTER.

a. Apply a few drops of S.A.E. 60 oil on control shaft at bearing points.

b. Apply graphite grease on valve shifter and on brake cam.

4-7. LUBRICATE TROLLEY WHEEL BEARINGS. If hoist is mounted on a trolley, apply light grease to wheel bearings as recommended by trolley literature.

WARNING

Before performing any internal work on hoist, remove load and be certain air is shut off.

SECTION V - MAINTENANCE

5-1. GENERAL. Preventive maintenance services required on

BUDGIT Air Hoists are for the most part simple periodic inspection procedures to determine condition of hoist components. Below are suggested inspection procedures, based on daily average hoist usage.

Hoist subjected to severe service or to adverse environments should be examined weekly or as conditions warrant.

5-2. THIRTY-DAY INSPECTION. Hoist may be left suspended.

a. Inspect Load Chain.

(1) Operate hoist under load and observe operation of chain over sprocket in both directions of chain travel. Chain should feed smoothly into and away from the sprocket. If chain binds, jumps or is noisy, first see that it is clean and properly lubricated. If trouble persists, inspect chain and mating parts for wear, distortion or other damage.

(2) **Coil Type Load Chain.** Clean chain for inspection. Examine visually for gouges, nicks, weld splatter, corrosion or distorted links. Slacken chain and check bearing surfaces between links for wear, Figure 5-1. Greatest wear will often occur at sprocket at high or low point of lift, particularly when hoist is subjected to repetitive lifting cycles. Case hardness of chain is about .015" deep. Chain must be replaced before the case is worn through. Also check chain for elongation using a vernier caliper (Figure 5-2). Select an unworn, unstretched section of chain (usually at slack or tail end) and measure and record the length over the number of chain links (pitches) indicated in Figure 5-2. Measure and record the same length of a worn section in the load side of the chain. Obtain the amount of wear by subtracting the measurement of the unworn section from the measurement of the worn section. If the result (amount of wear) is greater than the amount specified in the "ALLOWABLE CHAIN WEAR" table, the chain has elongated beyond the maximum allowable length and must be replaced. Chain with excessively pitted, corroded, nicked, gouged, twisted or worn links should be replaced using only factory approved chain. **Never weld or attempt to repair coil chain.**

Load chain for spark resistant models is made of stainless steel. Surface hardness treatment is no more than .001" deep and the core is lower in hardness than standard alloy steel load chain. For these reasons the rated capacity of spark resistant models is lower than that of standard models as follows:

Lines of Load Chain	Rated Load for Standard Model	Rated Load for Spark Resistant Model
1	1/4 Ton	—
1	1/2 Ton	3/8 Ton
2	1 Ton	3/4 Ton

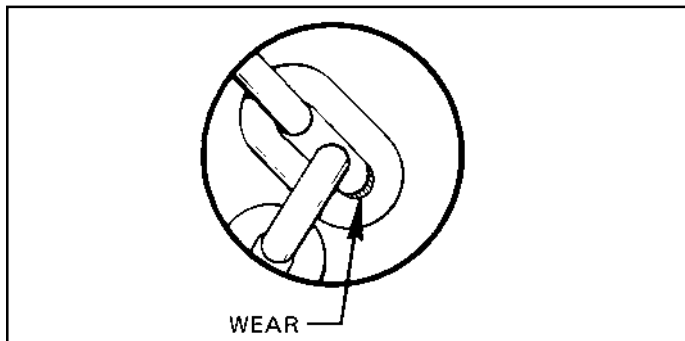

Figure 5-1. Check Chain Wear at Bearing Surfaces Between Links.

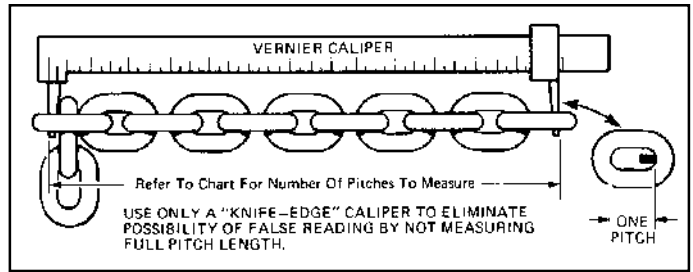

Figure 5-2. Checking Coil Chain Using Vernier Caliper.

ALLOWABLE CHAIN WEAR - ELONGATION

Chain Size (Wire Dia.)	No. of Pitches to Measure	Maximum Wear Limit
1/4"	13	.145"

⚠ CAUTION

Do not assume that load chain is safe because it measures below replacement points given herein. Other factors, such as those mentioned in visual checks above, may render chain unsafe or ready for replacement long before elongation replacement is necessary.

⚠ WARNING

When replacing coil load chain, use only factory approved chain conforming to factory specifications for material, hardness, strength and link dimensions. Chain not conforming to BUDGIT hoist specifications may be dangerous as it will not fit in the load sprocket and chain guide correctly, causing damage to hoist and it will wear prematurely, deform and eventually break.

(3) **Roller Type Load Chain.** Visually check for possible twists, broken links, wear or elongation. Check roller chains for elongation from wear by pulling chain taut and measuring as follows: On RC-625 or H-5 size chain (5/8" pitch), measure distance over a length of 20 pitches (center-to-center distance between 21 rivets) - it must not exceed 12-3/4 inches. If chain exceeds this limit, replace damaged section or install new load chain assembly. Check chain for twist. If twist in any 5' extension exceeds 15° replace chain. Check chain for camber. If any section has side bow exceeding 1/4" in five feet, replace chain. Use only factory approved chain. If chain is to be spliced to replace damaged section, it is recommended that this be done by a recognized **BUDGIT** Repair Station, since splicing link must have a spun head requiring special tools. Spring link must not be used except to secure the tail chain to the hoist frame. (See Figure 7-1.)

⚠ CAUTION

It must not be assumed that load chain is safe because it measures below replacement points given herein. Other factors, such as those mentioned in visual checks above, may render chain unsafe or ready for replacement long before elongation replacement is necessary.

(4) Check anchor end of chain at side of hoist frame for damage to last link, also connecting link on roller chain hoists. Replace damaged parts.

(5) Check connection of chain to lower block on 1/4, 3/8 and 1/2 ton hoists. Replace parts showing evidence of damage, twisting or elongation.

(6) Check connection of chain to anchor on side of suspension bracket on double reeved, 3/4 and 1 ton hoists. Replace parts showing evidence of damage, twisting or elongation.

(7) Lubricate load chain if required. See paragraph 4-4, Section IV.

b. Inspect Lower Block.

(1) Check for bent or distorted hook. If hook is opened beyond the dimension given in Figure 5-3, it must be replaced. Also check to see that hook swivels, and is free to pivot on roller chain models. Lubricate these points if necessary.

(2) On 3/4 and 1 ton hoists, check sprocket and bearings in lower block for freedom of movement and signs of damage. Lubricate if necessary. Replace damaged parts.

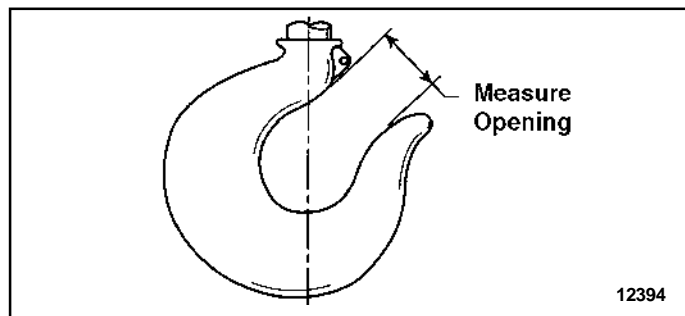

Hoist Rated Load (tons)		Hook Throat Opening	
		Normal Opening	Replace Hook if Opening is Greater Than
Std.	S.R.		
1/4	—	1-1/8"	1-9/32"
1/2	3/8	1-1/8"	1-9/32"
1	3/4	1-1/4"	1-7/16"

Figure 5-3. Upper Lower Hook Openings. (Shown with latch removed for clarity.)

(3) Check hook latches. Replace damaged or bent latches or broken springs.

▲WARNING

Hooks, upper or lower, damaged from chemicals, deformation or cracks or having more than 15 percent in excess of normal throat opening or more than 10 degrees twist from the plane of the unbent hook, or opened, allowing the hook latch to bypass hook tip must be replaced.

Any hook that is twisted or has excessive throat opening indicates abuse or overloading of the hoist. Other load bearing components of the hoist should be inspected for damage. (See Section V, paragraph 5-3 below.)

c. Inspect Upper Suspension.

(1) On hook suspended models, check for bent or distorted hook. If hook is opened beyond the dimension given in Figure 5-3, it must be replaced. Also check to see that hook swivels. Lubricate if necessary.

(2) On push trolley suspended models, check condition of trolley parts and lug bracket. Replace bracket or any trolley parts which are damaged or cracked.

(3) Check hook latch. Replace damaged or bent latch or broken spring.

d. Check Brake Operation.

(1) With air turned on and with rated load attached to lower hook, operate hoist to raise load, applying pressure to pull cord handle or throttle control lever. If load drifts down before the motor starts to actuate, the brake is out of adjustment.

(2) To adjust brake, insert hex key through hole in brake cover. Turn screw counterclockwise to tighten brake or clockwise to loosen brake (see Figure 7-15).

5-3. ANNUAL INSPECTION. Hoist must be disconnected from air service and removed from overhead suspension. **Hoists subjected to severe service or to adverse environments should be examined weekly or as conditions warrant.**

a. Hoist should be partially disassembled as necessary to inspect hoist parts noted in paragraphs b. through h. below. Refer to Section VII for disassembly and reassembly steps as noted.

b. **Inspect Brake.** Remove brake housing cover and brake shoes as outlined in paragraph 7-2.c. Check brake shoe linings and brake wheel for wear and scoring. Replace badly worn or scored parts. Check condition of brake cam and spring. Replace any damaged parts.

c. **Inspect Internal Load Gears.** Remove gear plate and intermediate gears as outlined in paragraph 7-2.f. Check condition of gear teeth on internal gear, intermediate gears, and motor shaft pinion. Replace worn or damaged parts.

d. **Inspect Chain Sprocket and Bearings.** Remove sprocket and internal gear as a unit, paragraph 7-2.f. Check condition of teeth or pockets on chain sprocket and inspect ball bearing assemblies. Replace worn or damaged parts.

e. **Inspect Throttle Valve Shifter.** Remove valve shifter and control shaft (paragraph 7-2.c.) and shifter pin (paragraph 7-2.d.). Check condition of shifter, pin and shaft bearings. Replace worn or damaged parts.

f. **Inspect Throttle Valve Housing.** Remove throttle housing assembly (paragraph 7-2.d.) and disassemble it as outlined. Check condition of throttle valve, valve bushing (in housing) and "O" rings on valves. Replace worn or damaged parts.

g. **Inspect Air Motor.** Remove air motor assembly from hoist (paragraph 7-2.e.). Check motor for condition of bearings, possible rotor rubbing on body or end plates, blade freedom in rotor slots, shaft and gear. If motor appears to be in good condition, do not service other than lubricating well with light oil.

h. **Reassemble and Test Hoist.** Reassemble hoist as outlined in Section VII, paragraph 7-4. After reassembly, test hoist in accordance with paragraph 7-5.

SECTION VI - TROUBLE SHOOTING

Trouble	Probable Cause	Remedy
6-1. Hoist does not operate.	<ol style="list-style-type: none"> 1. Insufficient air pressure at source. 2. Brake improperly adjusted. 3. Clogged air intake screen. 4. Excessive overload. 5. Clogged valve. 6. Valve shifter not functioning. 7. Motor failure. 	<ol style="list-style-type: none"> 1. Check air pressure and adjust 2. Adjust brake. 3. Shut off air - disconnect air hose - clean inlet swivel screen. 4. Reduce load. 5. Remove valve caps - remove any obstructions, clean and lubricate valve. 6. Check for proper installation of drive pin in valve shifter and control lever and also that shifter pin is assembled solidly to throttle valve. 7. Disassemble motor and check rotor blades. Replace defective parts.
6-2. Hoist will not hold load in suspension.	<ol style="list-style-type: none"> 1. Brake out of adjustment 2. Brake lining oily, glazed or badly worn. 3. Excessive overload. 	<ol style="list-style-type: none"> 1. Adjust Brake. 2. Remove brake arms and replace with new. 3. Reduce load
6-3. Control lever does not return to horizontal position.	<ol style="list-style-type: none"> 1. Control shaft bent. 2. Foreign material, rust or corrosion causing it to bind 3. Foreign material, rust or corrosion in control cylinders or pendant throttle control. 4. Brake improperly adjusted. 	<ol style="list-style-type: none"> 1. Remove shaft and straighten or replace. 2. Remove shaft and clean. Lubricate bearings brake cam and valve shifter. 3. Clean control cylinders. 4. Adjust brake
6-4. Hoist loses power.	<ol style="list-style-type: none"> 1. Insufficient air pressure. 2. Clogged air intake screen. 3. Clogged muffler screen. 4. Worn or broken rotor blades. 	<ol style="list-style-type: none"> 1. Check air pressure and adjust. 2. See this Section, paragraph 1. 3. Remove throttle valve housing. Clean screen and muffler. 4. Replace rotor blades.
6-5. Cannot regulate speed by control handles.	<ol style="list-style-type: none"> 1. Brake improperly adjusted. 2. Speed adjustment screws improperly set. 	<ol style="list-style-type: none"> 1. Adjust brake. 2. Readjust screws.
6-6. Cannot regulate speed by pendant handle.	<ol style="list-style-type: none"> 1. Brake improperly adjusted. 2. Control cylinders improperly adjusted. 	<ol style="list-style-type: none"> 1. Adjust brake. 2. Adjust control cylinder set screws.
6-7. Hoist lifting or lowering speed differs from rated speed at full load.	<ol style="list-style-type: none"> 1. Valve shifter or control shaft bent or damaged. 2. Incorrect air pressure or inadequate air supply. 3. Speed adjustment screws improperly set. 4. Loss of power. 	<ol style="list-style-type: none"> 1. Repair or install new parts, and lubricate. 2. Check pressure near hoist when hoist is operating. 3. Readjust screws. See Figure 2-4. 4. See paragraph 6-4.

SECTION VII DISASSEMBLY AND REASSEMBLY

7-1. GENERAL.

a. The following disassembly and reassembly instructions apply to all models of **BUDGIT** Air Hoists. Where needed, variations to instructions are provided to cover differences between models (suspensions, controls, load chain, capacity sizes) with applicable models specifically noted.

b. A complete tear down procedure is given. However, if only certain parts require repair or replacement, a partial teardown may be performed, using applicable portions of the instructions.

c. For easier handling during disassembly, the following disassembly steps may, where conditions permit, be completed before hoist is removed from its overhead suspension or disconnected from its air supply: Remove chain container, if hoist is so equipped. Remove lower block and load chain assembly, following procedure outlined in paragraph 7-2.b.

d. These hoists contain precision machined parts and should be handled with care at disassembly and reassembly. When removing or installing parts with press fits, be careful to apply pressure evenly. On ball bearings, apply pressure to face of inner or outer race, whichever is adjacent to mating part. This will avoid damage to bearing races from brinelling by pressing through bearing balls. Apply a thin film of oil to parts having a tight fit when installed.

7-2. DISASSEMBLY.

a. Removal of Hoist from Overhead Suspension.

- (1) Turn off air at source.
- (2) Operate control to bleed air from hoist.
- (3) Disconnect air hose at inlet swivel.
- (4) Remove hoist from overhead suspension.

b. Removal of Lower Block and Load Chain Assembly.

(1) On models with single reeved load chains (1/4, 3/8 and 1/2 ton), disconnect end of load chain from tail end anchor boss at side of hoist frame. Remove chain anchor by prying off spring clip and remove connecting link, attaching chain to anchor boss on roller chain models (Figure 7-1). Remove socket head cap screw, holding end link to tail end anchor on coil chain models. If hoist is connected to air service, run chain out of hoist by operating control in "lowering" direction. If hoist is not connected to air service, the chain can be pulled out of hoist by hand while holding brake open by pulling down on control lever.

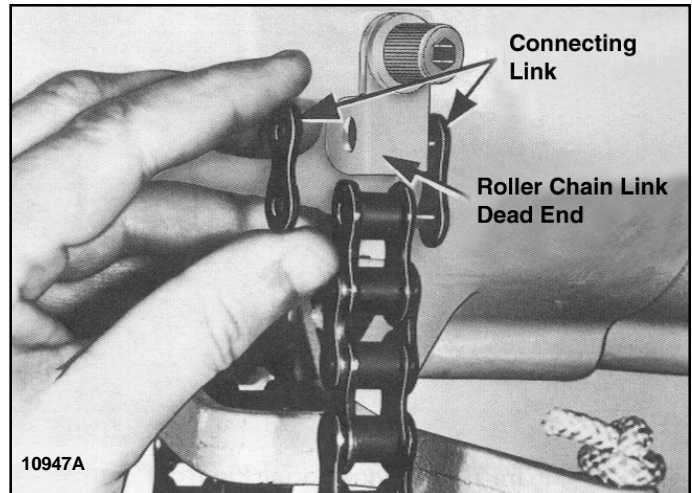

Figure 7-1. Removing Connecting Link at Tail End of Load Chain (Roller Chain Models).

(2) On models with double reeved chains (3/4 and 1 ton), disconnect end of chain as in paragraph (1) above, run chain out of hoist by operating it in "lowering" direction, and disconnect opposite end of chain from anchor at side of upper suspension bracket.

(3) On single reeved 1/4, 3/8 and 1/2 ton models, separate load chain (coil or roller type) from lower block assembly. Drive out small spring pin securing lower block pin in lower block and push out lower block pin to release chain. On roller chain models, an adapter is used to attach chain to lower block. This adapter is removed from end of chain by first driving out small spring pin and then pushing out adapter pin.

(4) Lower blocks (1/4, 3/8 and 1/2 ton) are of a pinned construction, permitting individual replacement of body, thrust bearing, or hook. To disassemble, drive spring pin from hook nut. With pin removed, hold hook nut from turning with drift punch and rotate hook to unscrew it from nut. Separate hook, bearing shield, needle bearing and two thrust washers from body. Hook and nut are drilled at assembly and are replaced only as an assembly.

(5) On 3/4 and 1 ton (double reeved) models, the lower block assembly is disassembled by removing socket head screws and nuts holding body halves together.

c. Removal of Brake Cover, Control Lever and Load Brake.

(1) On pendant throttle control models, for convenience, disconnect control hoses from air cylinders, open strain cable "S" hook at eye bolt on throttle housing and remove pendant throttle control assembly from hoist. Refer to paragraph 7-6 for disassembly and reassembly of pendant throttle control.

(2) Remove two screws securing brake housing cover to frame and lift off cover.

(3) To remove control lever and shaft, drive spring pins from control lever (Figure 7-2) and valve shifter at end of shaft using a drift punch. Lightly tap valve shifter end of shaft and withdraw shaft by pulling on brake cam end (Figure 7-3). As shaft is withdrawn, valve shifter and control lever will fall free.

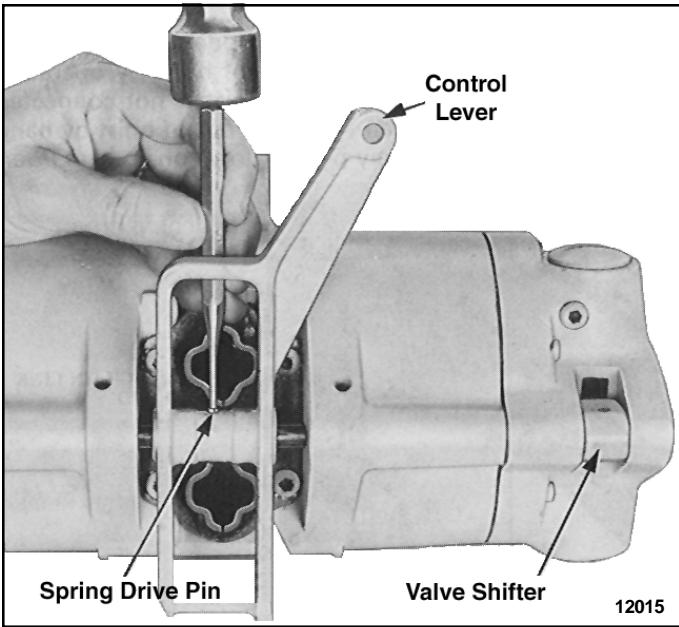

Figure 7-2. Driving Spring Pin from Control Lever and Shaft.

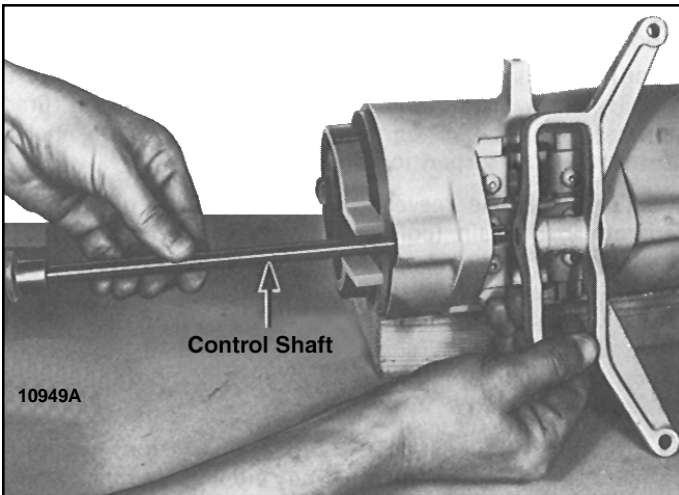

Figure 7-3. Removing Control Shaft.

(4) Remove brake spring by carefully prying it up evenly with a screwdriver until spring is about halfway off. Using brake spring spreader (Part No. 306989, Figure 7-4), remove spring from brake arms (Figure 7-5).



Figure 7-4. Special Tool for Removing Brake Spring.

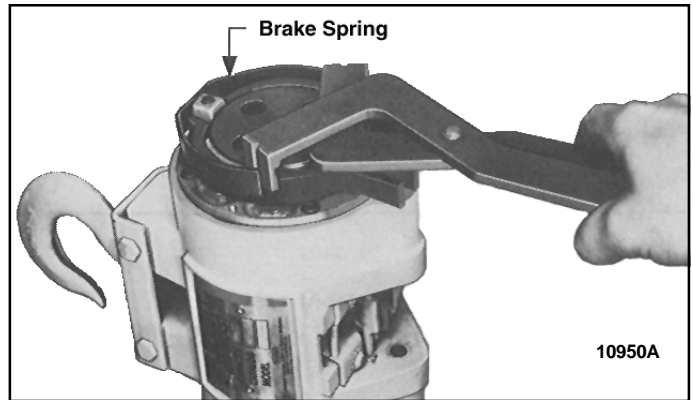

Figure 7-5. Removing Brake Spring Using Special Tool.

⚠ WARNING

Do not pry spring all the way off with screwdriver, since spring is apt to fly in most any direction with considerable force.

(5) Remove brake shoes. Be sure not to lose steel fulcrum balls.

(6) Remove steel balls from recesses in sides of upper brake boss.

d. Removal and Disassembly of Control Head Assembly.

(1) Remove control head assembly by taking out six socket head screws and lifting assembly from frame (Figure 7-6).

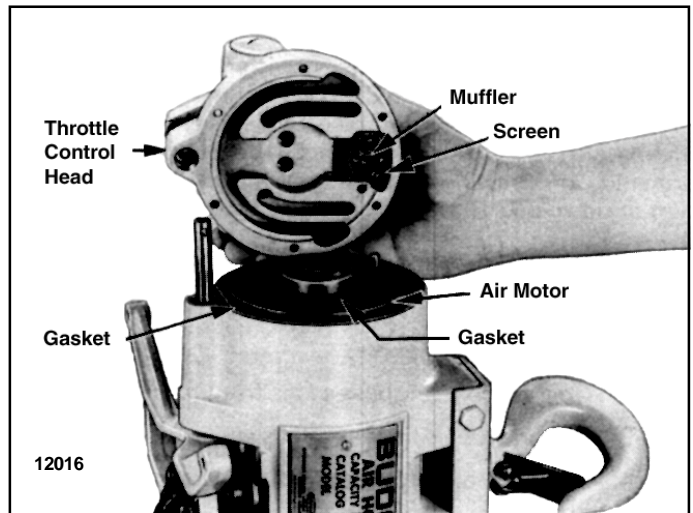

Figure 7-6. Removing Control Head Assembly.

(2) Lift muffler and screen from recess in control head housing.

(3) On pendant throttle control models, remove control cylinder assemblies from each side of control head housing (Figure 7-14). On pull cord control models, remove throttle valve spring retainer caps from each side of housing (Figure 7-13). Valve springs, spring guides and "O" ring seals can now be removed from valve bore at each side of housing.

(4) The throttle valve is retained in the control head by the valve shifter pin. The pin is assembled with LOCTITE on the threads and should not be removed for routine servicing. If valve is to be removed, use a hex key to remove pin from bottom of throttle valve. (See Figure 7-13.) The valve can now be removed from bushing in housing. The throttle valve bushing is pressed into place and honed to provide a .0001 to .0003 inch clearance with valve. If bushing is scored, worn, or otherwise damaged, the housing and bushing assembly should be replaced along with the valve.

(5) Remove air inlet swivel body and bushing from top of housing. Retain bushing gasket for reuse. Pull strainer screen from housing bore.

(6) Remove retaining ring from bottom of swivel body and pull off bushing. Remove "O" ring seal from its groove in bushing.

(7) Disassemble control cylinder (pendant throttle control models) by removing cylinder lock ring. Cylinder and cap will come off with lock ring. Lift out spring and then remove piston and seal assembly from cylinder. Piston shaft "O" ring seal and retainer washer will drop out as piston is removed.

e. Removal and Disassembly of Air Motor.

(1) Remove air motor from hoist frame by placing entire unit on motor end and lifting frame straight up as shown. **DO NOT** tap on end of motor shaft since this will destroy critical rotor alignment and damage motor. If necessary, motor may be grasped at bearing boss on the dead end plate to assist in removal.

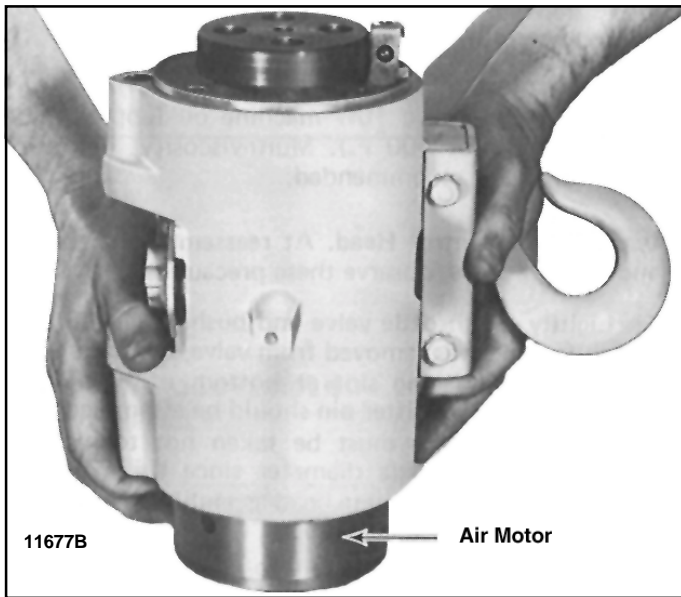

Figure 7-7. Removing Motor from Frame.

(2) Motor is a unit construction and generally should not be disassembled. However, if it is felt that the blades need replacing, the dead (opposite drive end) end plate can be removed to inspect the blades.

(3) Removal of dead end plate requires a puller to remove the end plate bearing from the shaft.

(4) Remove (3) button head cap screws from dead end plate. Attach puller to end plate with two 1/4-28 screws taking care **not** to turn them into end plate more than 1/4 inch, thus hitting

and damaging rotor. Remove end plate by turning puller screw against motor shaft.

(5) Inspect blades for wear or breakage. Inspect end plate, rotor and body for damage. Since the end plates and body are matched and doweled at assembly, they are not serviced separately. If there is significant damage, replace motor.

f. Removal of Brake Wheel, Internal Load Gears and Sprocket.

(1) Rotate brake wheel until holes in web are aligned with four socket head cap screws (Figure 7-8). Remove screws, then lift brake wheel off (Figure 7-9) after prying up lightly and evenly with screwdriver to free ball bearing. Ball bearing and clamp plate are pressed off after removing retaining ring from wheel hub.

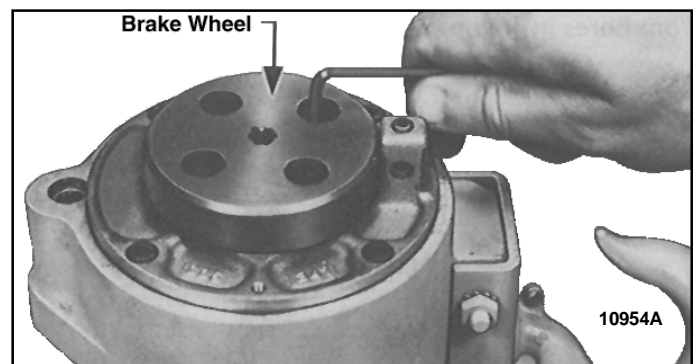

Figure 7-8. Removing Cap Screws Securing Bearing Clamp Plate.

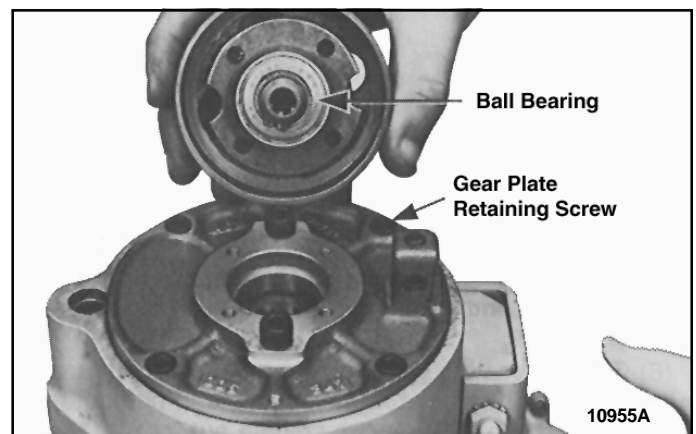

Figure 7-9. Removing Brake Wheel and Ball Bearing Assembly.

(2) Remove four socket head screws securing gear plate to frame and lift off plate and intermediate gears as a unit (Figure 7-10). Do not remove the two socket head screws from flange around brake wheel bearing hole (Figure 7-9) unless it is necessary to replace intermediate gears.

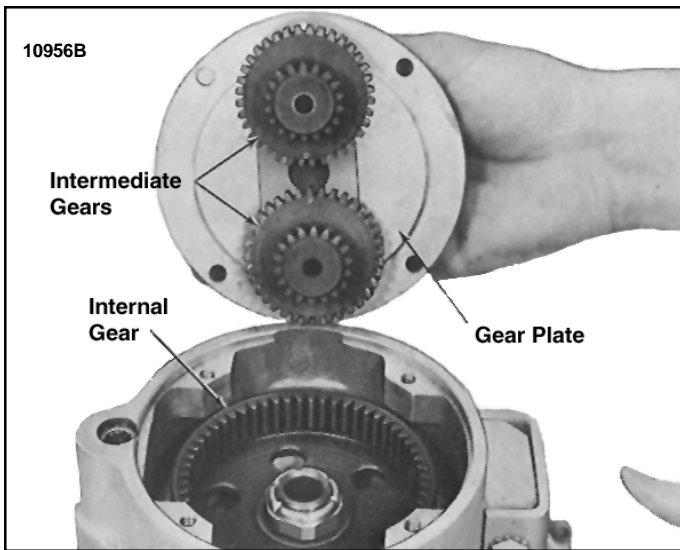

Figure 7-10. Removing Gear Plate and Intermediate Gears.

(3) On roller chain models, remove two fillister head screws attaching chain stripper to frame and lift out stripper. Chain stripper on coil chain models is integral with chain guide.

(4) On coil chain models, remove four fillister head screws attaching chain guide and stripper assembly to hoist frame. This will free guide to allow sprocket to be pulled through it as it is removed in step (5). Refer to Figure 7-11.

(5) Rotate internal gear (Figure 7-10) until holes in web align with six socket head screws securing bearing clamp plate to frame. Remove internal gear, chain sprocket and ball bearings as a unit (Figures 7-11 and 7-12). It may be necessary to tap sprocket to free ball bearings from bores in frame.

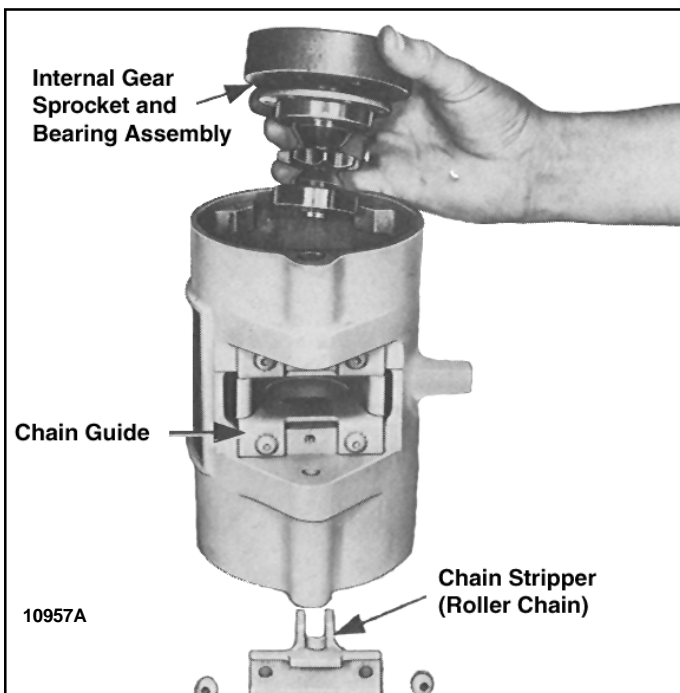

Figure 7-11. Removing Internal Gear, Chain Sprocket and Ball Bearing Assembly (Roller Chain Model).

(6) To disassemble intermediate gear, sprocket and ball bearing assembly, remove retaining ring and pull outer ball bearing from sprocket. Remove spindle nut from other end of sprocket and pull internal gear free of sprocket shaft. Remove clamp plate and pull off remaining ball bearing.

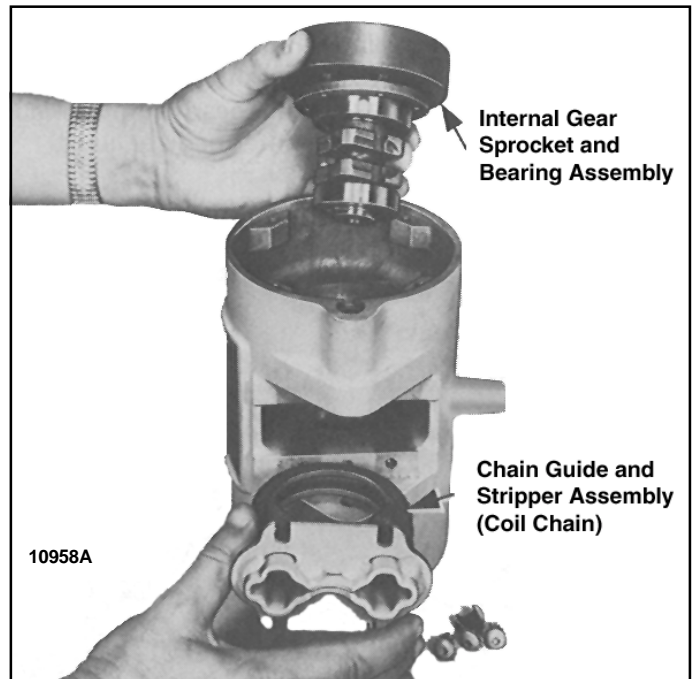

Figure 7-12. Removing Internal Gear, Chain Sprocket and Ball Bearing Assembly (Coil Chain Model).

7-3. CLEANING AND INSPECTION. Before reassembly, all parts should be thoroughly cleaned and inspected to determine their serviceability. Replace all parts that are excessively worn or damaged. Minor nicks and scratches should be filed to remove raised edges.

Note: Bearings that are sealed are lubricated at the factory for normal life of the bearing and must not be washed. If they are exposed to wash or infiltration with foreign matter, they must be replaced.

7-4. REASSEMBLY.

a. **General.** The procedure to be followed to reassemble hoist is in reverse order of the disassembly steps outlined in paragraph 7-2. Listed below are special assembly precautions which should be observed to assure proper assembly.

b. **Assembly of Motor.** When reassembling motor, observe the following precautions:

(1) If any blade replacement is required, the full set of blades should be replaced. Blades must be installed so that the edges with chamfered corners face down into the slots.

(2) Reassemble end plate and bearing as follows. Remove dowel pins locating end plate to body. Support shaft and press bearing onto shaft, using a drift that contacts both inner and outer race of bearing. Use a feeler gage between end plate and body to make sure the bearing is not pressed onto shaft so far as to bow the end plate. Align dowel pin holes in end plate with those in body and assemble pins. Assemble three button head cap screws.

(3) Rotor blade replacement is the only field service

recommended on air motors. See paragraph 7-2.e. For any other repairs the air motor should be returned for factory servicing.

(4) Lubricate motor with small amount of Air Hoist Motor Oil or good grade 10W machine oil (approximate viscosity 150 SSU at 100°F.). Multi-viscosity, detergent type engine oil is not recommended.

c. **Assembly of Control Head.** At reassembly of control head and throttle valve, observe these precautions:

(1) Lightly oil throttle valve and bushing with S.A.E. 20 oil. If shifter pin was removed from valve, assemble valve with threaded hole facing slot at bottom of bushing in housing (Figure 7-13). Shifter pin should be assembled with LOCTITE. Extreme care must be taken not to get any LOCTITE on valve outside diameter since this will lock up valve and scrap the complete head assembly.

Note: Apply lubricating oil to "O" rings and "U" seals before installing and take care during installation so as not to cut, pinch, or otherwise damage them.

(2) Use new "O" ring seals at each end of valve. Install spring guides and valve springs in bores on each side of housing and secure with spring retainer (pull cord models) or control cylinders (pendant throttle control models). Use new "O" ring gaskets.

(3) At reassembly of control cylinders (pendant throttle control models), use new "U" type seals on piston heads and "O" ring seals on piston stems. Be sure "U" type seals face direction illustrated in Figure 7-14.

(4) Use new "O" ring gaskets on adjusting screws. When installing screws in control head housing, turn them in until heads are flush or slightly below face of housing. Adjustment is accomplished during testing of hoist, paragraph 2-4.

(5) At reassembly of screen and air inlet swivel, install a new "O" ring seal inside swivel bushing.

(6) In mounting control head housing on hoist, use a new motor-to-head air seal gasket and a new head-to-frame gasket.

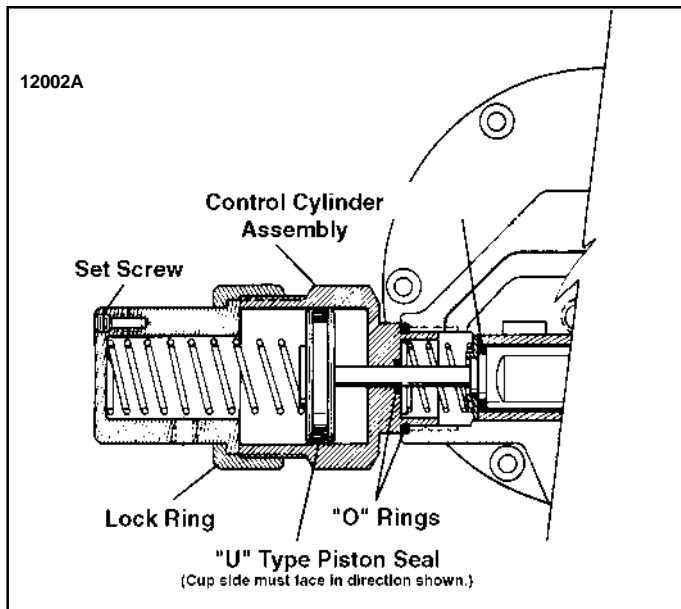

Figure 7-14. Section View Showing Assembly of Control Cylinder on Control Head (Pendant Throttle Control Models).

d. **Assembly of Brake.** If the brake linings show excessive wear, replace brake shoes. In reassembling the brake, the brake wheel assembly goes into position first and is fastened in place by the four screws referred to in paragraph 7-2.f.(1). (See Figures 7-8 and 7-9.) Now place the steel fulcrum balls in their receiving cup, using a small amount of thick grease to hold them in place. The balls should retract completely into the receiving cups. Now place the shoes up to the fulcrum balls and brake wheel. Replace the brake spring, using the spreader tool to start the spring over the shoes. (See Figures 7-4 and 7-5.) Tap the spring into place. Adjust brake shoes per instructions in Figure 7-15.

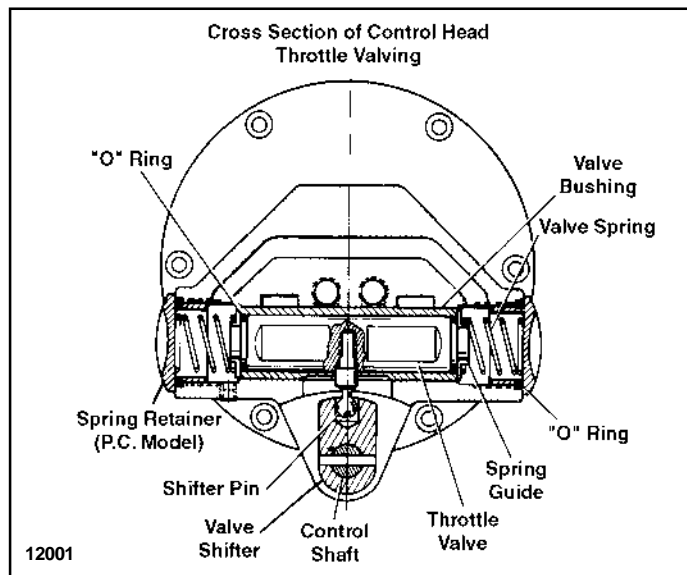

Figure 7-13. Section View Showing Assembly of Throttle Valve, Springs and Valve Shifter in Control Head.

Brake Adjustment at Reassembly:

Turn screw "A" in until arms pivot on fulcrum ball to make "C" = .010 - .015".

Checking Adjustment Without Load:

Without load, and with air turned off, open brake arms manually, by operating limit lever, to see if brake wheel can be turned freely by hand. If wheel refuses to turn, the brake may not be properly adjusted. Recheck adjustment, and then if the wheel does not turn freely, check for possible damage, such as bent brake arms, improper lining, brake cam slippage or other malfunctions in the unit.

Brake Adjustment With Load:

(1) With load on hook, pull "UP" control cord (or press "UP" lever), slowly! Load must not creep down before motor starts. Turn adjusting screw out as required.

(2) Brake must stop and hold load in both directions.

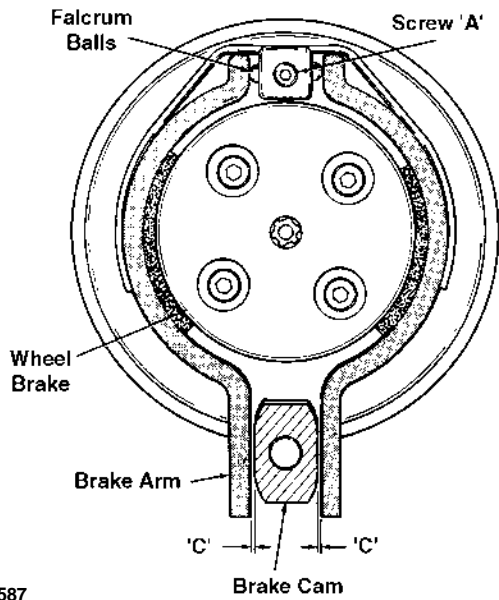

12587

Figure 7-15. Brake Adjustments.

e. Installation of Load Chain.

(1) To install roller type load chain, first temporarily install connecting link on tail end of load chain. Then, with the air off, brake cover removed, and brake shoes locked in "open" position (with wedge between control lever and hoist body), turn brake wheel in "hoist" direction and feed chain in through lever control into chain sprocket. Once chain is over sprocket, brake cover can be replaced, hoist connected to air, and the chain run through hoist under power until sufficient chain has been run through to allow tail end to be attached to boss on side of frame with chain anchor. On single reeved hoist, attach lower block to load end of chain. On double reeved hoist, run lower block assembly onto chain and attach load end of chain to lug suspension bracket.

(2) When installing coil chain on the hoist, make sure the weld on the second link faces "out" or away from the sprocket. (See Figures 7-16 and 7-17). Now, with the air off, brake cover removed, and brake shoes locked in "open" position (with wedge between control lever and hoist body), turn brake wheel in "hoist" direction and feed chain in through lever control into chain sprocket. Continue to feed the chain through until approximately 15" to 16" hangs through the tail chain side of

the hoist. Take the first link and swing it up (do not twist) (see Figure 7-16) to the frame boss and fasten in place. The rest of the chain can be pulled through, and then the lower block fastened in place (on single reeved hoist). On double reeved hoist, allow approximately 17" to 18" of chain to hang on the lifting direction side (Figure 7-17). Run the lower block assembly onto chain and swing (do not twist) the remainder of the chain up and attach to lug on suspension bracket. Remove wedge from between lever and frame and replace covers.

Note: Chain must not be twisted and link welds must be positioned as shown in Figure 7-17.

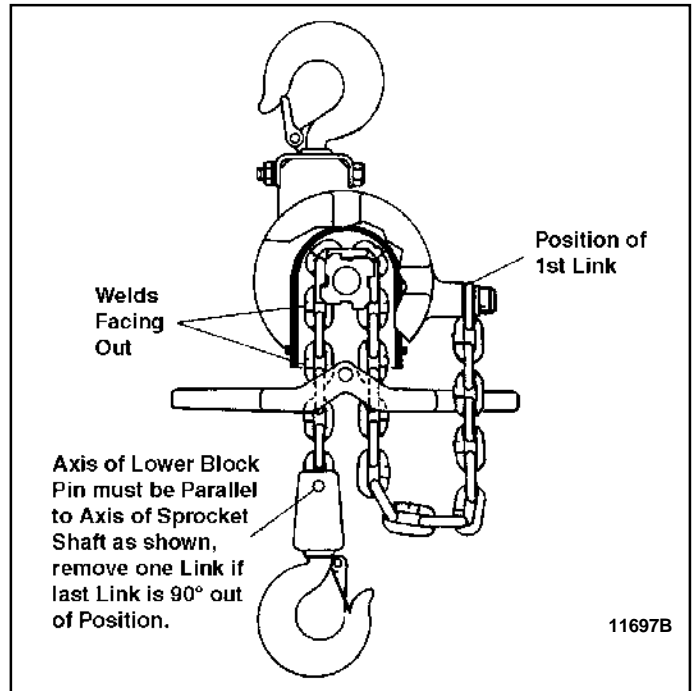

11697B

Figure 7-16. Installing Single Reeved Load Chain (1/4, 3/8 and 1/2 ton models).

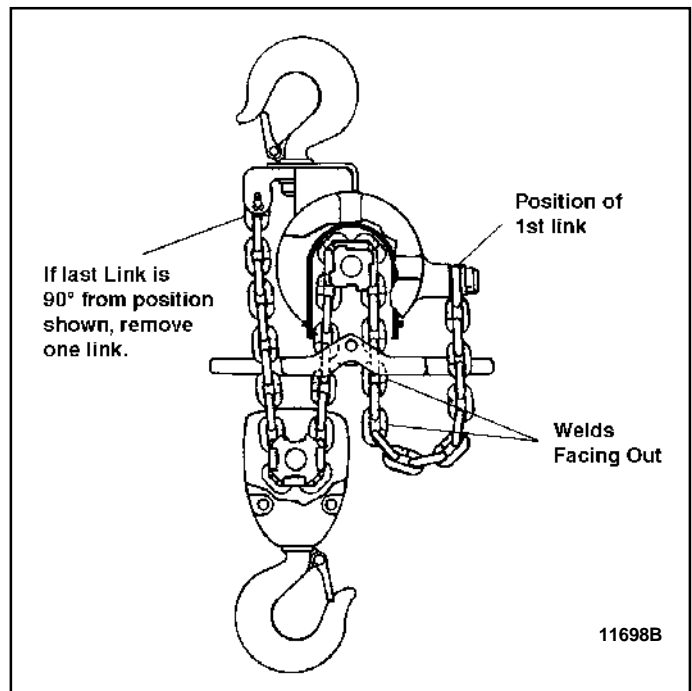

11698B

Figure 7-17. Installing Double Reeved Load Chain (3/4 and 1 ton models).

f. **Assembly of Control Cords.** On pull cord models, control cords must be attached to control lever as follows: Facing air inlet end of hoist, the cord to top handle (arrow pointing up) should be attached to right end of lever; cord to bottom handle (arrow pointing down) attached to left end of lever.

g. **Assembly of Pendant Throttle Control.** On pendant throttle control models, control hoses must be attached to cylinders on throttle valve housing as follows: Facing air inlet end of hoist, the hose to "DOWN" lever side of pendant handle should be connected to cylinder on right-hand side of housing; hose to "UP" lever side should be connected to cylinder on left-hand side of housing. The third hose connects to tapped hole in bottom left side of control head and at top rear of handle.

7-5. TESTING HOIST.

a. **General.** After completion of assembly and before placing hoist in service, hoist should be tested to insure proper operation. To test: Suspend hoist from an overhead supporting member of sufficient strength to carry combined weight of hoist and rated load; connect to air supply of correct pressure; and perform the following checks and adjustments:

b. **Check Control Operation.** Pull down on pull cord handle or depress lever on pendant control briefly to determine that hook travels in the direction to correspond with control being operated. If load hook travels in a direction opposite to control being operated, the pull cords or control hoses are improperly installed. With Pendant Control Hoists the control lever should attain a full throw when each lever on the handle is fully depressed. If full movement of control lever is not accomplished, the set screw in the corresponding control cylinder should be turned in. If full movement occurs before lever is fully depressed, the set screw should be turned out. The screw should not extend beyond end of cylinder.

c. **Check Hoist Under Rated Load.** Attach rated load to lower hook and check hoist operation.

(1) Operate hoist to raise load. When control is released, hoist should stop and hold load at that level.

(2) Operate hoist to lower load a short distance, then release control. Hoist should stop and hold load at that level.

(3) Operate hoist to lower load and observe rate of speed at which load descends. Adjust lowering and hoisting speeds to the desired rate of speed as outlined in paragraph 2-4.

7-6. PENDANT THROTTLE CONTROL ASSEMBLY.

a. **General.** After long periods of use, the pendant throttle control assembly will require some maintenance attention. To service the control handle assembly, shut off air supply, bleed air from hoist and control, and disconnect hoses and strain cable at control handle. Disassemble and reassemble control handle as outlined in paragraphs b. and c. below.

b. Disassembly.

(1) Remove four screws and lift control lever guard from handle.

(2) Drive lever pin from handle housing and separate two control levers from housing.

(3) Using a suitable spanner tool, unscrew bushings and valves from handle housing. Remove air seal gaskets from bushing seats in the handle assembly. Remove "O" ring seals from ends of valves and pull valves and valve springs from bushings. Remove "O" ring gaskets from bushings.

c. Reassembly.

(1) Clean all parts in cleaning solvent and carefully inspect for wear or damage before reassembly.

(2) Install new air seal gaskets on bushing seats in the handle housing.

(3) Install new "O" ring gaskets on valve bushings. Insert springs and valves in bushings and install new "O" ring seals on ends of valves. Valves and bushings can now be reinstalled in handle housing using spanner tool. "O" rings should be lubricated before reassembly.

(4) Position control levers on housing, align holes and install lever pin.

(5) Place guard over levers and secure to housing with four machine screws.

(6) Reinstall control handle assembly on hoist. Attach control hoses to handle housing as outlined in paragraph 7-4.g.

SECTION VIII - PARTS LIST

8-1. INTRODUCTION. Parts illustrations and parts lists covering **BUDGIT** Air Hoists bearing model number given on front cover will be found on following pages. When ordering replacement parts, include with order the exact Catalog Number and Model Number from hoist nameplate.

8-2. PARTS LIST. The parts lists consist of four columns. The first column, Ref. No., is the index number of the parts on the exploded view illustrations. The second column, Part Number, lists the number of the part for ordering purposes. The third column names and gives a brief description to help identify the part. The last column(s) list the total number of times the item is used in the assembly of which it is a part.

Notice: Information herein is subject to change without notice. Parts must be order from a recognized **BUDGIT** Repair Station or from a **BUDGIT** Hoist Distributor.

WARNING

Do not lift more than rated load except for test purposes. Overloading hoist can result in chain breakage, hook deformation and other failures which can cause serious injury and damage. A test at greater than rated load should be a properly supervised official test only, not an operator test. If any load sustaining parts have been altered, replaced or repaired, hoist should be load tested at 125% of rated load by a designated, qualified person, with a written report recording test load, as recommended in ANSI B30.16 Safety Standards.

 **WARNING**

NON-FACTORY AUTHORIZATIONS OR MODIFICATION OF EQUIPMENT AND USE OF NON-FACTORY REPAIR PARTS CAN LEAD TO DANGEROUS OPERATION AND INJURY.

TO AVOID INJURY:

- Do not alter or modify equipment without factory authorization.
- Do use only factory provided replacement parts.

The numbers assigned to the parts of our various assemblies in our parts lists are not the part numbers used in manufacturing the part. They are identification numbers, that when given with the catalog number, permit us to identify, select or manufacture, and ship the correct part needed.

NOTES

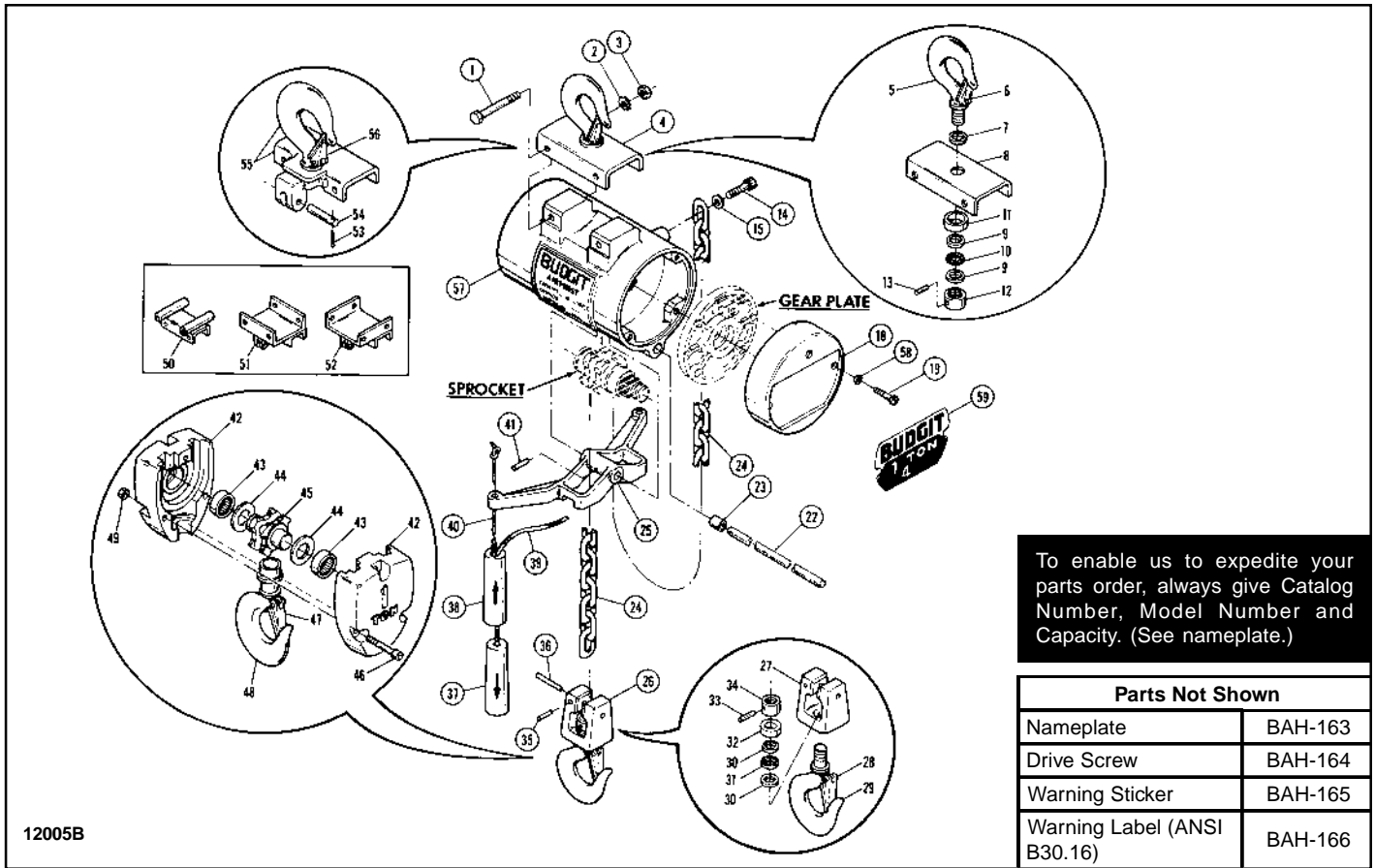

12005B

Figure 8-1. Frame and External Parts - Coil Chain Models

Ref. No.	Part Number	Description	Quantity Required		
			1/4 Ton	1/2 Ton	1 Ton
1	BAH-105	Bolt - Suspension Bracket	2	2	2
2	BAH-108	Lockwasher - Shakeproof, External	2	2	2
3	BAH-107	Nut - Hex, Cadmium Plated	2	2	2
† 4	BAH-106	Hook and Bracket Assembly - Suspension	1	1	—
† 5	BAH-145	Hook and Nut Assembly - Upper (Includes Ref. No. 6)	1	1	—
† 6	BAH-146	Latch Kit	1	1	—
7	BAH-147	Bushing - Machinery	1	1	—
8	BAH-148	Bracket - Suspension	1	1	—
9	BAH-149	Washer - Thrust, Bearing	2	2	—
10	BAH-150	Bearing Assembly - Needle	1	1	—
11	BAH-151	Shield - Bearing	1	1	—
12	*	Nut - Hook	1	1	—
13	BAH-152	Pin - Spring Drive	1	1	—
14	BAH-170	Screw - Hex Socket Head Cap	1	1	1
15	BAH-171	Washer - Flat	1	1	1
18	BAH-172	Cover - Brake Housing	1	1	1
19	BAH-113	Screw - Slotted Head	2	2	2
22	BAH-153	Shaft - Control	1	1	1
23	BAH-119	Bushing - Oilite, Control Shaft	3	3	3
† 24	BAH-115	**Chain - Load, Coil Type (11'-5" Lg.)	1	1	—
	BAH-116	**Chain - Load, Coil Type (22'-7" Lg.)	—	—	1
† 25	BAH-117	Lever - Control	1	1	1
† 26	BAH-154	Block Assembly - Lower (1/4 Ton)	1	—	—
	BAH-155	Block Assembly - Lower (1/2 Ton)	—	1	—
† 27	BAH-156	Body - Lower Block (1/4 Ton)	1	—	—
	BAH-157	Body - Lower Block (1/2 Ton)	—	1	—
† 28	BAH-158	Latch Kit	1	1	—

(Continued on following page)

Figure 8-1. Frame and External Parts — Coil Chain Models (Continued)

Ref. No.	Part Number	Description	Quantity Required		
			1/4 Ton	1/2 Ton	1 Ton
†29	BAH-160	Hook and Nut Assembly (With Latch)	1	1	–
30	BAH-149	Washer - Thrust, Bearing	2	2	–
31	BAH-150	Bearing Assembly - Needle	1	1	–
32	BAH-151	Shield - Bearing	1	1	–
33	BAH-152	Pin - Spring Drive	1	1	–
34	*	Nut - Hook	1	1	–
35	BAH-121	Pin - Spring Drive	1	1	–
†36	BAH-122	Pin - Connecting, Lower Block	1	1	–
	BAH-124	Cord Assembly - Control (Includes Ref. Nos. 37 thru 40)	1	1	1
37	BAH-125	Handle - Down Control	1	1	1
38	BAH-126	Handle - Up Control	1	1	1
39	BAH-128	Cord - Down Control	1	1	1
40	BAH-127	Cord - Up Control	1	1	1
	BAH-129	Clip - Cord, 1/4" (Not Shown)	1	1	1
41	BAH-161	Pin - Spring Drive, Control Lever	1	1	1
†	BAH-130	Block Assembly-Lower (1 Ton, Includes Ref. Nos. 42 thru 49)	–	–	1
†42	BAH-132	Body - Lower Block (Pair)	–	–	1
43	BAH-135	Bearing Assembly - Needle	–	–	2
†44	BAH-136	Washer	–	–	2
†45	BAH-137	Sprocket - Coil Chain	–	–	1
†46	BAH-131	Screw - Socket Head Cap	–	–	3
†47	BAH-146	Latch Kit - Lower Hook	–	–	1
†48	BAH-133	Hook, Bearing and Nut Assembly (With Latch)	–	–	1
49	BAH-134	Nut - Hex, Self-Locking	–	–	3
50	BAH-141	Bracket - Lug Suspension (Parallel Mount)	1	1	–
51	BAH-142	Bracket - Lug Suspension (Parallel Mount)	–	–	1
52	BAH-143	Bracket - Lug Suspension (Cross Mount)	–	–	1
53	BAH-138	Pin - Cotter	–	–	2
54	BAH-139	Pin - Chain Anchor (Continued on following page)	–	–	1
†55	BAH-140	Hook and Bracket Assembly (With Latch)	–	–	1
†56	BAH-146	Latch Kit	–	–	1
57	BAH-101	Frame Assembly (Includes Ref. No. 23)	1	1	1
58	BAH-162	Lockwasher - Spring	2	2	2
†59		Label - Rated Load			
	BAH-173	1/4 Ton	1	–	–
	BAH-174	1/2 Ton	–	1	–
	BAH-175	1 Ton	–	–	1

† See Special Parts Table (Figure 8-7) for Spark Resistant Models.

* Hook nut is drilled in place on hook shank and is not available separately.

** Load chain lengths listed are for standard 10 foot lifts. Longer chains are available on order.

NOTES

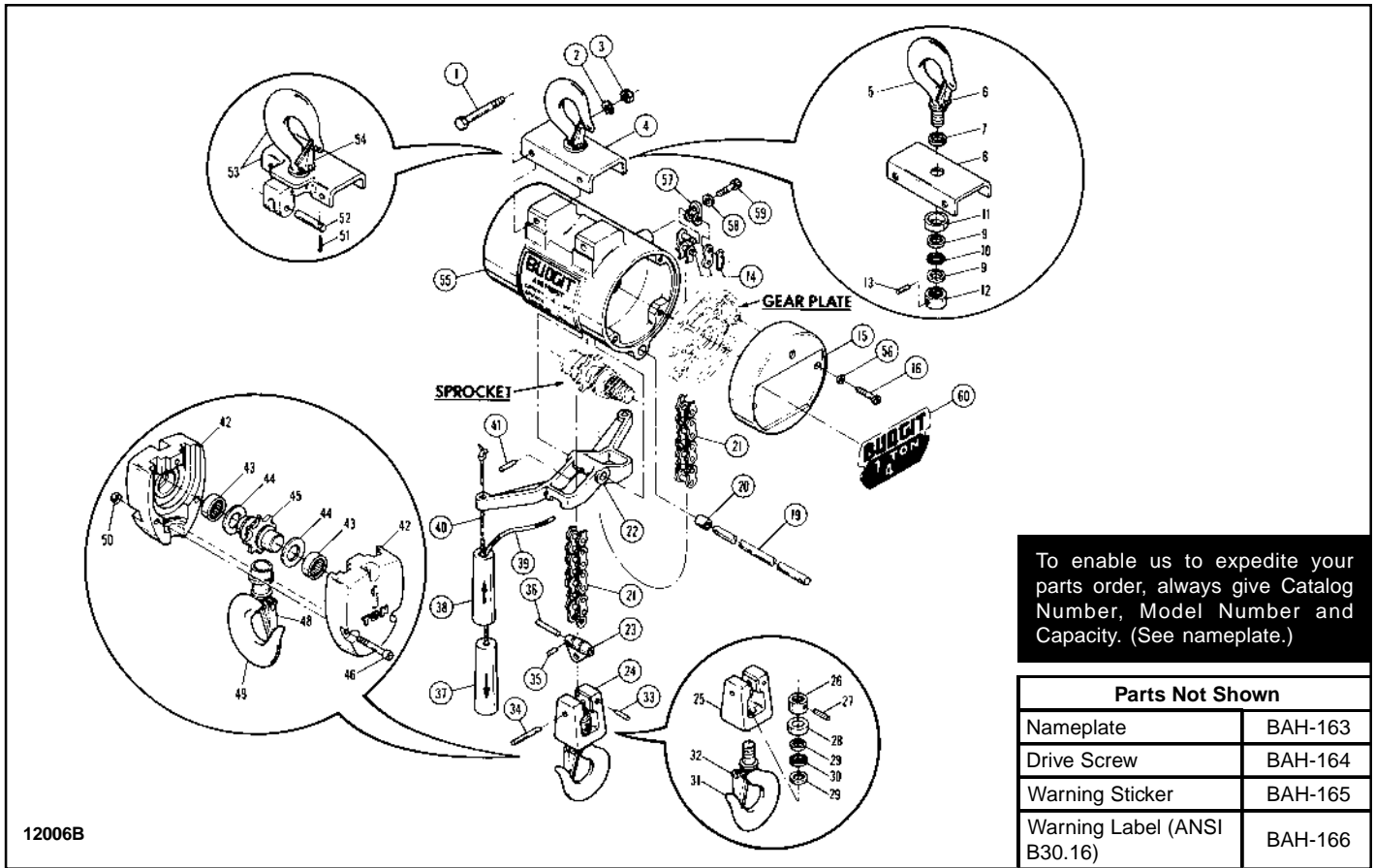

Figure 8-2. Frame and External Parts - Roller Chain Models

Ref. No.	Part Number	Description	Quantity Required		
			1/4 Ton	1/2 Ton	1 Ton
1	BAH-105	Bolt - Suspension Bracket	2	2	2
2	BAH-108	Lockwasher - Shakeproof, External	2	2	2
3	BAH-107	Nut - Hex, Cadmium Plated	2	2	2
4	BAH-106	Hook and Bracket Assembly - Suspension	1	1	1
5	BAH-145	Hook and Nut Assembly - Upper (Includes Ref. No. 6)	1	1	1
6	BAH-146	Latch Kit	1	1	1
7	BAH-147	Bushing - Machinery	1	1	-
8	BAH-148	Bracket - Suspension	1	1	1
9	BAH-149	Washer - Thrust, Bearing	2	2	1
10	BAH-150	Bearing Assembly - Needle	1	1	-
11	BAH-151	Shield - Bearing	1	1	-
12	*	Nut - Hook	1	1	1
13	BAH-152	Pin - Spring Drive	1	1	1
14	BAH-201	Link Assembly - Roller Chain (For Connecting Tail End of Chain Only. Must Not Be Used to Join Chain.)	1	1	1
15	BAH-172	Cover - Brake Housing	1	1	1
16	BAH-113	Screw - Slotted Head	2	2	2
19	BAH-153	Shaft - Control	1	1	1
20	BAH-119	Bushing - Oilite, Control Shaft	3	3	3
21	BAH-203	**Chain - Load, Roller Type (11'-1/2" Lg.)	1	1	-
	BAH-204	**Chain - Load, Roller Type (22'-1" Lg.)	-	-	1
22	BAH-117	Lever - Control	1	1	1
23	BAH-215	Adapter - Roller Load Chain	1	1	-
	BAH-216	Block Assembly - Lower, Complete (Includes Ref. Nos. 23, 24, 33, 34, 35 & 36)	1	-	-
	BAH-217	Block Assembly- Lower, Complete (Includes Ref. Nos. 23, 24, 33, 34, 35 & 36)	-	1	-

(Continued on following page)

Figure 8-2. Frame and External Parts - Roller Chain Models (Continued)

Ref. No.	Part Number	Description	Quantity Required		
			1/4 Ton	1/2 Ton	1 Ton
24	BAH-154	Block Assembly - Lower (Includes Ref. Nos. 25 thru 32)	1	-	-
	BAH-155	Block Assembly - Lower (Includes Ref. Nos. 25 thru 32)	-	1	-
25	BAH-156	Body - Lower Block (1/4 Ton)	1	-	-
	BAH-157	Body - Lower Block (1/2 Ton)	-	1	-
26	*	Nut - Hook	1	1	-
27	BAH-152	Pin - Spring Drive	1	1	-
28	BAH-151	Shield - Bearing	1	1	-
29	BAH-149	Washer - Thrust, Bearing	2	2	-
30	BAH-150	Bearing Assembly - Needle	1	1	-
31	BAH-160	Hook and Nut Assembly (With Latch)	1	1	-
32	BAH-158	Latch Kit	1	1	-
33	BAH-121	Pin - Spring Drive	1	1	-
34	BAH-122	Pin - Connecting, Lower Block	1	1	-
35	BAH-218	Pin - Spring Drive	1	1	-
36	BAH-219	Pin - Connecting, Roller Chain Adapter	1	1	-
	BAH-124	Cord Assembly - Control (Includes Ref. Nos. 37 thru 40)	1	1	1
37	BAH-125	Handle - Down Control	1	1	1
38	BAH-126	Handle - Up Control	1	1	1
39	BAH-128	Cord - Down Control	1	1	1
40	BAH-127	Cord - Up Control	1	1	1
	BAH-129	Clip - Cord, 1/4" (Not Shown)	1	1	1
41	BAH-161	Pin - Spring Drive, Control Lever	1	1	1
	BAH-207	Block Assembly-Lower (1 Ton, Includes Ref. Nos. 42 thru 50)	-	-	1
42	BAH-220	Body - Lower Block (Pair)	-	-	1
43	BAH-135	Bearing Assembly - Needle	-	-	2
44	BAH-136	Washer	-	-	2
45	BAH-211	Sprocket - Roller Chain	-	-	1
46	BAH-131	Screw - Socket Head Cap	-	-	3
48	BAH-146	Latch Kit	-	-	1
49	BAH-133	Hook, Bearing and Nut Assembly (With Latch)	-	-	1
50	BAH-134	Nut - Hex, Self-Locking	-	-	3
51	BAH-138	Pin - Cotter	-	-	2
52	BAH-213	Pin - Chain Anchor	-	-	1
53	BAH-212	Hook and Bracket Assembly (With Latch)	-	-	1
54	BAH-146	Latch Kit	-	-	1
55	BAH-101	Frame Assembly (Includes Ref. No. 20)	1	1	1
56	BAH-162	Lockwasher - Spring	2	2	2
57	BAH-222	Dead End - Roller Chain Link	1	1	1
58	BAH-171	Washer - Flat	1	1	1
59	BAH-170	Screw - Hex Socket Head Cap	1	1	1
60		Label - Rated Load			
	BAH-173	1/4 Ton	1	-	-
	BAH-174	1/2 Ton	-	1	-
	BAH-175	1 Ton	-	-	1

* Hook nut is drilled in place on hook shank and is not available separately.

** Load chain lengths listed are for standard 10 foot lifts. Longer chains are available on order.

NOTES

To enable us to expedite your parts order, always give Catalog Number, Model Number and Capacity. (See nameplate.)

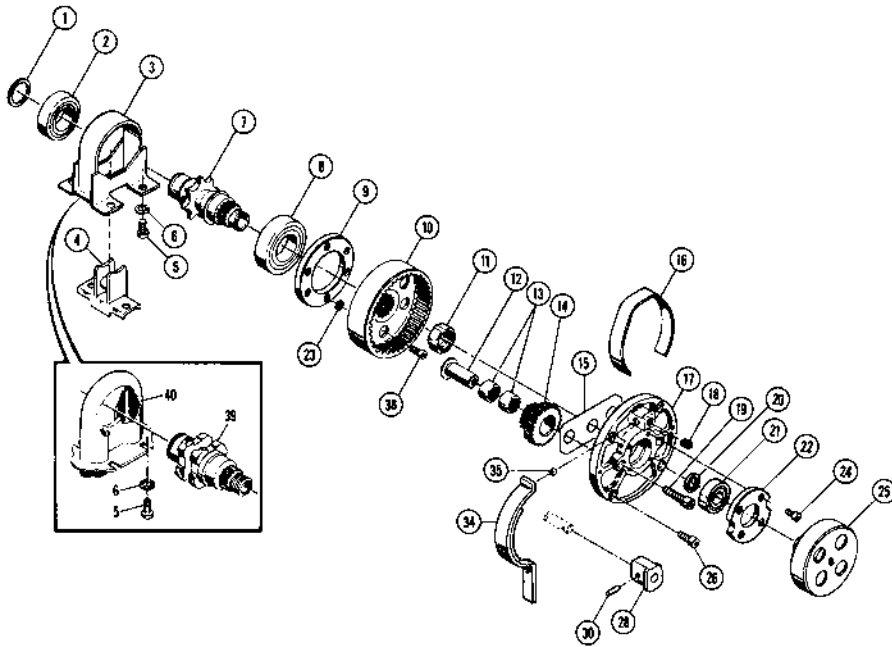

12007B

Figure 8-3. Gearing, Sprocket and Load Brake Parts - All Models.

Ref. No.	Part Number	Description	Qty. Req'd.
1	BAH-301	Ring - Retaining, External	1
2	BAH-302	Bearing Assembly - Ball, Sprocket	1
3	BAH-303	Guide Assembly - Chain (Roller Type Only)	1
4	BAH-304	Stripper - Chain (Roller Type Only)	1
5	BAH-305	Screw - Button Head	*6
6	BAH-306	Lockwasher - Shakeproof, Internal	*6
7	BAH-307	Sprocket - Chain (Roller Type Only)	1
8	BAH-308	Bearing Assembly - Ball, Sprocket	1
9	BAH-309	Plate - Clamp, Bearing	1
10	BAH-312	Gear - Internal	1
11	BAH-313	Nut - Spindle	1
12	BAH-314	Shaft - Intermediate Gear	2
13	BAH-315	Bearing Assembly - Needle	4
14	BAH-316	Gear - Intermediate	2
15	BAH-350	Thrust Plate	1
16	BAH-355	Spring - Brake Shoe	1
17	BAH-351	Plate - Gear	1
18	BAH-352	Screw	1
19	BAH-318	Screw - Socket Head (Self-Locking)	2
20	BAH-325	Ring - Retaining, External	1
21	BAH-326	Bearing Assembly - Ball, Brake Wheel	1
22	BAH-327	Plate - Clamp, Brake Wheel Bearing	1
23	BAH-311	Lockwasher - Shakeproof, Internal	6
24	BAH-360	Screw - Socket Head	4
25	BAH-328	Wheel - Load Brake	1
26	BAH-345	Screw - Socket Head (Self-Locking)	4
28	BAH-353	Cam - Brake Actuator	1
30	BAH-338	Pin - Spring Drive, Brake Cam	1
34	BAH-354	Shoe Assembly - Brake	2
35	BAH-321	Ball - Steel, Brake Fulcrum	2
38	BAH-347	Screw - Socket Head	6
†39	BAH-339	Sprocket - Chain (Coil Type Only)	1
†40	BAH-340	Guide and Stripper Assembly - Chain (Coil Type Only)	1

† See Special Parts Table (Figure 8-7) for Spark Resistant Models.

* Quantities shown are for roller chain models. Coil chain models require four (4) each.

To enable us to expedite your parts order, always give Catalog Number, Model Number and Capacity. (See nameplate.)

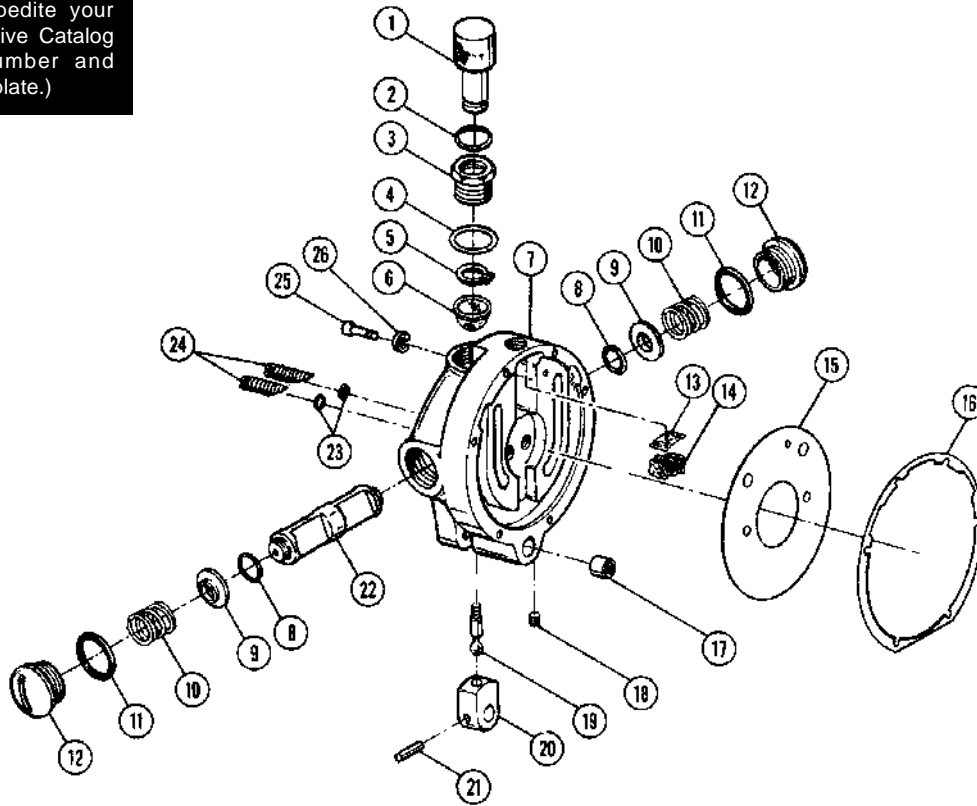

12008

Figure 8-4. Throttle Control Head Parts - All Models.

Ref. No.	Part Number	Description	Qty. Req'd.
1	BAH-1101	Body -Swivel, Inlet (3/8" - 18 N.P.T.)	1
2	BAH-1102	Seal - "O" Ring, Inlet Swivel	1
3	BAH-1103	Bushing - Inlet Swivel	1
4	BAH-1104	Gasket - Inlet Swivel Bushing (Brass)	1
5	BAH-1105	Ring - Retaining, External	1
6	BAH-1106	Screen - Inlet Swivel	1
7	BAH-1126	Housing Assembly - Control Head Includes Ref. No. 22 & Throttle Valve Bushing (Not Shown)	1
8	BAH-1108	Seal - "O" Ring, Throttle Valve	2
9	BAH-1109	Guide - Spring, Throttle Valve	2
10	BAH-1110	Spring - Throttle Valve	2
11	BAH-1111	Gasket - "O" Ring, Valve Spring Retainer	2
12	BAH-1112	Retainer - Spring, Throttle Valve	2
13	BAH-1113	Screen - Muffler	1
14	BAH-1114	Muffler - Exhaust	1
15	BAH-812	Gasket - Air Seal, Motor End Plate	1
16	BAH-813	Gasket - Control Head to Frame	1
17	BAH-1115	Bearing Assembly - Needle, Control Shaft	1
18	BAH-1116	Plug - Pipe, 1/8" N.P.T.	1
19	BAH-1117	Pin - Valve Shifter	1
20	BAH-1118	Shifter - Throttle Valve	1
21	BAH-161	Pin - Spring Drive	1
22	BAH-1125	Valve -Throttle	1
23	BAH-1120	Gasket - "O" Ring, Adjusting Screw	2
24	BAH-1121	Screw - Adjusting, Speed	2
25	BAH-1122	Screw - Hex Socket Cap	6
26	BAH-1123	Lockwasher - Spring	6

To enable us to expedite your parts order, always give Catalog Number, Model Number and Capacity. (See nameplate.)

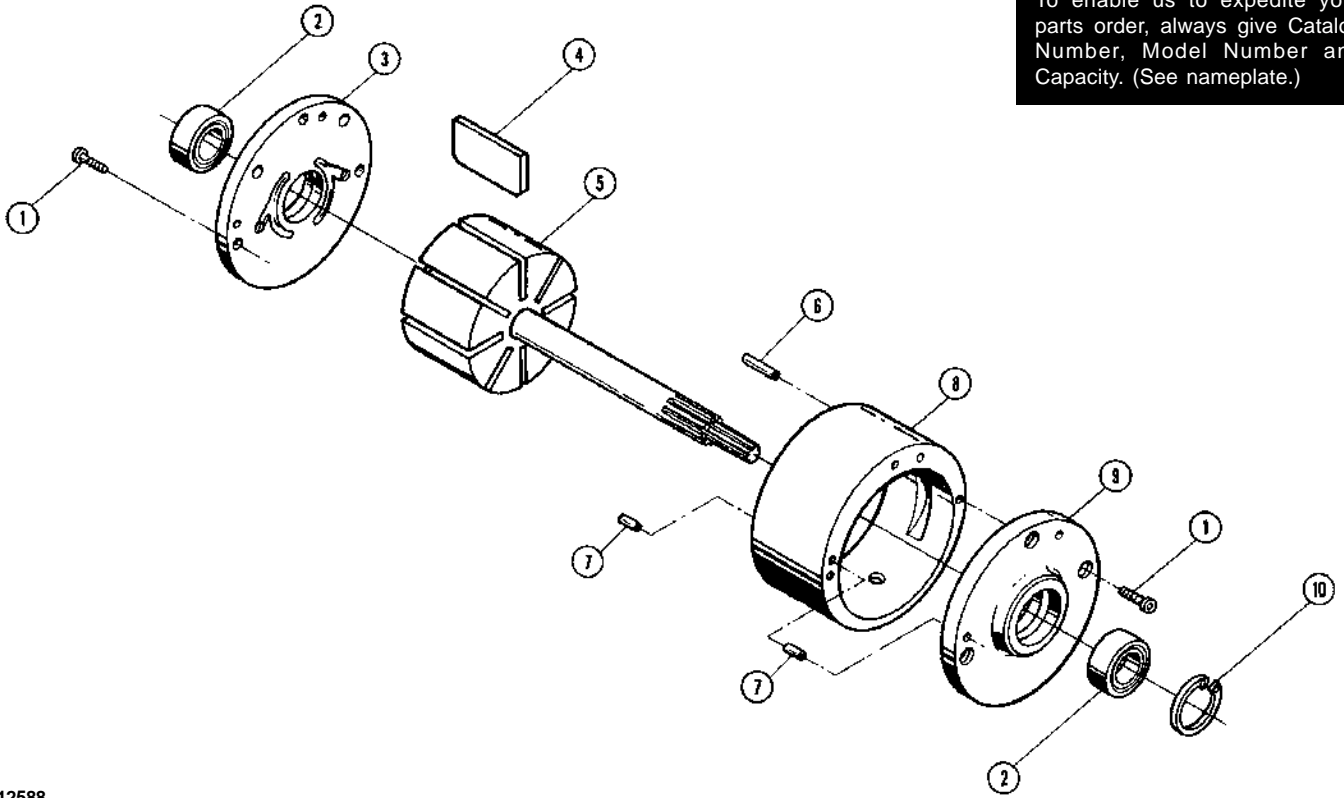

12588

Figure 8-5. Motor Parts - All Models.

Ref. No.	Part Number	Description	Qty. Req'd.
	BAH-950	Motor Assembly - Air	1
1	BAH-951	Screw - Hex Socket Button Head	6
2	BAH-952	Bearing - Ball	2
3	BAH-953	Plate - End, Dead	1
4	BAH-954	Blade - Rotor	8
5	BAH-955	Rotor and Shaft Assembly	1
6	BAH-956	Pin - Spring	1
7	BAH-957	Pin - Spring	3
8	BAH-958	Body	1
9	BAH-959	Plate - End, Drive	1
10	BAH-960	Ring - Retaining	1

NOTES

To enable us to expedite your parts order, always give Catalog Number, Model Number and Capacity. (See nameplate.)

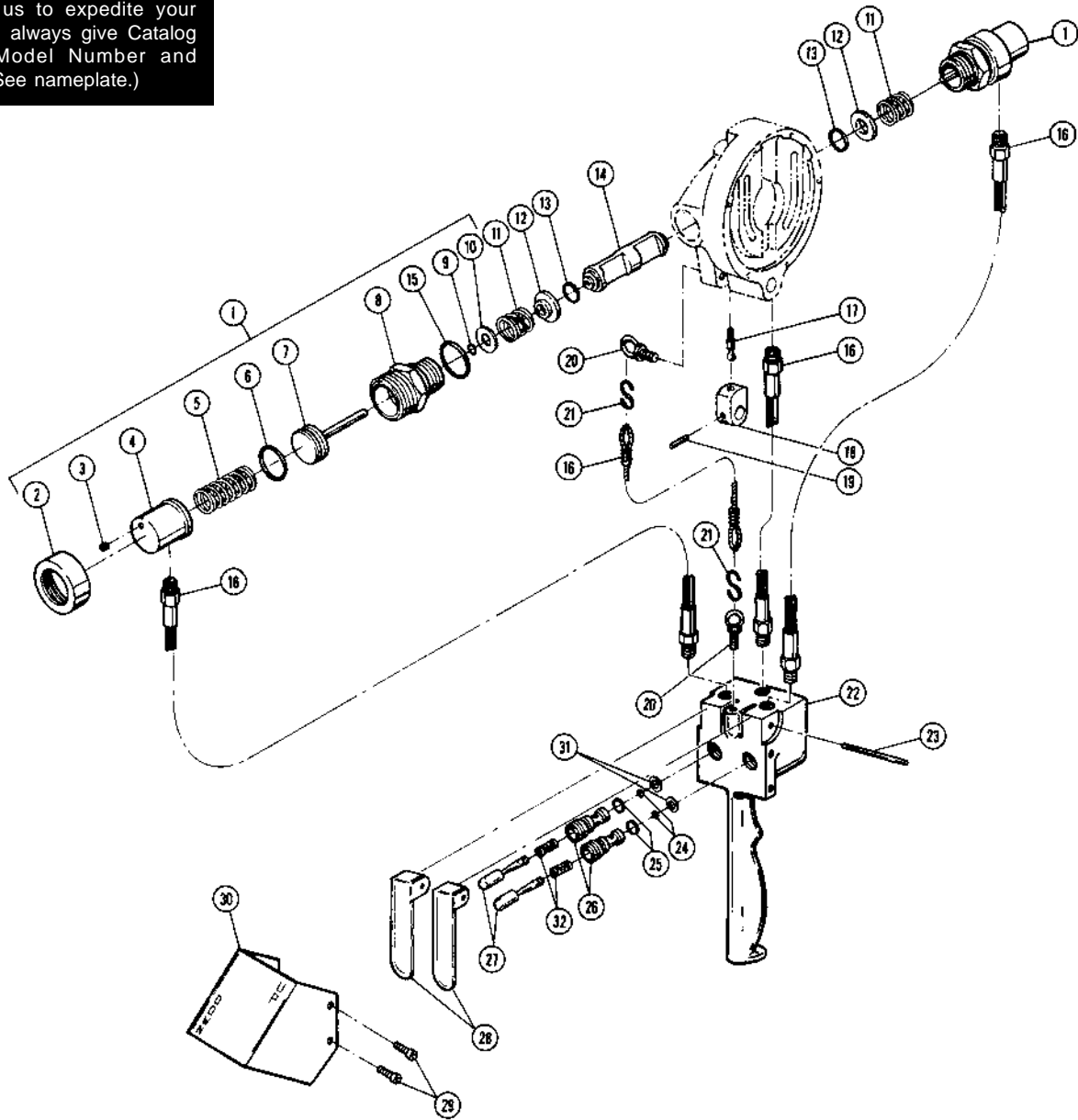

12010B

Figure 8-6. Control Cylinder and Pendant Throttle Control Parts.

Ref. No.	Part Number	Description	Qty. Req'd.
1	BAH-1201	Cylinder Assembly - Control, Pendant (Includes Ref. Nos. 2 thru 10 and 15)	2
2	BAH-1202	Ring - Lock, Cylinder	1
3	BAH-1203	Screw - Set, Hex Socket	1
4	BAH-1204	Cap - End, Cylinder	1
5	BAH-1205	Spring - Piston, Cylinder	1
6	BAH-1206	Seal - "U" Ring, Piston	1
7	BAH-1207	Piston - Control Cylinder	1
8	BAH-1208	Cylinder - Pendant Control	1
9	BAH-1209	Seal - "O" Ring, Piston Stem	1
10	BAH-1210	Retainer - "O" Ring Seal	1
11	BAH-1110	Spring - Throttle Valve	2
12	BAH-1109	Guide - Spring, Throttle Valve	2
13	BAH-1108	Seal - "O" Ring, Throttle Valve	2
14	BAH-1125	Valve - Throttle	1
15	BAH-1111	Gasket - "O" Ring, Control Cylinder	2

(Continued on following page)

Figure 8-6. Control Cylinder and Pendant Throttle Control Parts. (Continued)

Ref. No.	Part Number	Description	Qty. Req'd.
16	BAH-1211	Hose and Strain Cable Assembly - Pendant Throttle For 10' Lift	1
	BAH-1212	For 12' Lift	1
	BAH-1213	For 15' Lift	1
	BAH-1214	For 20' Lift	1
17	BAH-1117	Pin - Valve Shifter	1
18	BAH-1118	Shifter - Throttle Valve	1
19	BAH-161	Pin - Spring Drive	1
20	BAH-1231	Eye Bolt - Strain Cable	2
21	BAH-1232	"S" Hook - Wire, Strain Cable	2
	BAH-1217	Handle Assembly - Pendant Throttle Control (Includes Ref. Nos. 22 thru 32)	1
22	BAH-1218	Case - Control Handle	1
23	BAH-1219	Pin - Lever	1
24	BAH-1220	Gasket - "O" Ring, Valve	2
25	BAH-1221	Gasket - "O" Ring, Valve Bushing	2
26	BAH-1222	Bushing - Throttle Valve	2
27	BAH-1223	Valve - Throttle Control	2
28	BAH-1224	Lever - Throttle Control	2
29	BAH-1225	Screw - Machine, Round Slotted Head	4
30	BAH-1226	Guard - Control Lever	1
31	BAH-1227	Gasket	2
32	BAH-1230	Spring	2

Figure Number	Ref. Number	Part Number	Description	Quantity Required	
				3/8 Ton	3/4 Ton
8-1	4	BAH-1303	Hook and Bracket Assembly - Upper	1	-
8-1	5	BAH-1304	Hook, Nut and Latch Assembly - Upper	1	-
8-1	6	BAH-1305	Latch Kit - Upper Hook	1	-
8-1	24	BAH-1308	Chain - Coil Type, Load (11'-5" Lg.)	1	-
	24	BAH-1309	Chain - Coil Type, Load (22'-7" Lg.)	-	1
8-1	25	BAH-1310	Lever - Control	1	1
8-1	26	BAH-1315	Block Assembly - Lower, Complete	1	-
8-1	27	BAH-1318	Body - Lower Block	1	-
8-1	28	BAH-1320	Latch Kit - Lower Hook	1	-
8-1	29	BAH-1319	Hook, Nut and Latch Assembly - Lower	1	-
8-1	36	BAH-1312	Pin - Connecting, Lower Block	1	-
8-1		BAH-1322	Block Assembly - Lower, Coil Chain	-	1
8-1	42	BAH-1326	Body - Lower Block	-	1 Pair
8-1	44	BAH-1330	Washer	-	2
8-1	45	BAH-1332	Sprocket - Coil Chain, Lower Block	-	1
8-1	46	BAH-1324	Screw - Socket Head	-	3
8-1	47	BAH-1328	Latch Kit - Lower Hook	-	1
8-1	48	BAH-1327	Hook, Nut and Latch Assembly - Lower	-	1
8-1	55	BAH-1333	Hook and Bracket Assembly - Upper (Includes Latch)	-	1
8-1	56	BAH-1334	Latch Kit - Upper Hook	-	1
8-1	59	BAH-1340	Label - Rated Load	1	-
8-1	59	BAH-1341	Label - Rated Load	-	1
8-3	39	BAH-1335	Sprocket - Coil Chain	1	1
8-3	40	BAH-1336	Guide and Stripper Assembly - Coil Chain	1	1

Figure 8-7. Special Parts Table - Spark Resistant Models.

Recommended Spare Parts for Your Budget Series 2200 Air Hoist

Certain parts of your hoist will, in time, require replacement under normal wear conditions. It is suggested that the following parts be purchased for your hoist as spares for future use.

One Pair of Brake Shoes
One Set of Gaskets
One Set of Oil Seals and "O" Rings
One Set of Motor Blades

Note: When ordering parts always furnish Model Number and Catalog Number of Hoist and Lift of Hoist on which the parts are to be used.

Parts for your hoist are available from your local authorized **BUDGIT** repair station. For the location of your nearest repair station, write:

Yale•Lift-Tech
P.O. Box 769
Muskegon, MI 49443-0769

Phone: **800 742-9269**
Fax: **800 742-9270**

WARRANTY

WARRANTY AND LIMITATION OF REMEDY AND LIABILITY

A. Seller warrants that its products and parts, when shipped, and its work (including installation, construction and start-up), when performed, will meet applicable specifications, will be of good quality and will be free from defects in material and workmanship. All claims for defective products or parts under this warranty must be made in writing immediately upon discovery and in any event, within one (1) year from shipment of the applicable item unless Seller specifically assumes installation, construction or start-up responsibility. All claims for defective products or parts when Seller specifically assumes installation, construction or start-up responsibility and all claims for defective work must be made in writing immediately upon discovery and in any event, within one (1) year from completion of the applicable work by Seller, provided; however, all claims for defective products and parts made in writing no later than eighteen (18) months after shipment. Defective items must be held for Seller's inspection and returned to the original f.o.b. point upon request. THE FOREGOING IS EXPRESSLY IN LIEU OF ALL OTHER WARRANTIES WHATSOEVER, EXPRESS, IMPLIED AND STATUTORY, INCLUDING, WITHOUT LIMITATION, THE IMPLIED WARRANTIES OF MERCHANTABILITY AND FITNESS.

B. Upon Buyer's submission of a claim as provided above and its substantiation, Seller shall at its option either (i) repair or replace its product, part or work at either the original f.o.b. point of delivery or at Seller's authorized service station nearest Buyer or (ii) refund an equitable portion of the purchase price.

C. This warranty is contingent upon Buyer's proper maintenance and care of Seller's products, and does not extend to normal wear and tear. Seller reserves the right to void warranty in event of Buyer's use of inappropriate materials in the course of repair or maintenance, or if Seller's products have been dismantled prior to submission to Seller for warranty inspection.

D. The foregoing is Seller's only obligation and Buyer's exclusive remedy for breach of warranty and is Buyer's exclusive remedy hereunder by way of breach of contract, tort, strict liability or otherwise. In no event shall Buyer be entitled to or Seller liable for incidental or consequential damages. Any action for breach of this agreement must be commenced within one (1) year after the cause of action has accrued.

BUDGIT®