

IMPULSE®·VG+ *Series 2*

Flux Vector Crane Controls

Instruction Manual



Electromotive Systems

VG+S214912-05 Software #14912 May 2003

Part Number: 005-1068

© Copyright 2003 Electromotive Systems

For use with software versions 14908-14912

©2003 ELECTROMOTIVE SYSTEMS

All rights reserved. This notice applies to all copyrighted materials included with this product, including, but not limited to, this manual and software embodied within the product. This manual is intended for the sole use of the persons to whom it was provided, and any unauthorized distribution of the manual or dispersal of its contents is strictly forbidden. This manual may not be reproduced in whole or in part by any means whatsoever without the expressed written permission of Magnetek's Electromotive Systems division.

***DANGER, WARNING, CAUTION, and NOTE* Statements**

DANGER, WARNING, CAUTION, and Note statements are used throughout this manual to emphasize important and critical information. You must read these statements to help ensure safety and to prevent product damage. The statements are defined below.



DANGER

DANGER indicates an imminently hazardous situation which, if not avoided, will result in death or serious injury. This signal word is to be limited to the most extreme situations.



WARNING

WARNING indicates a potentially hazardous situation which, if not avoided, could result in death or serious injury.



CAUTION

CAUTION indicates a potentially hazardous situation which, if not avoided, could result in minor or moderate injury. It may also be used to alert against unsafe practices.

NOTE: A *NOTE* statement is used to notify people of installation, operation, programming, or maintenance information that is important, but not hazard-related.

Disclaimer of Warranty

Electromotive Systems hereafter referred to as Company, assumes no responsibility for improper programming of a drive by untrained personnel. A drive should only be programmed by a trained technician who has read and understand the contents of this manual. Improper programming of a drive can lead to unexpected, undesirable, or unsafe operation or performance of the drive. This may result in damage to equipment or personal injury. Company shall not be liable for economic loss, property damage, or other consequential damages or physical injury sustained by the purchaser or by any third party as a result of such programming. Company neither assumes nor authorizes any other person to assume for Company any other liability in connection with the sale or use of this product.



WARNING

Improper programming of a drive can lead to unexpected, undesirable, or unsafe operation or performance of the drive.

Contents:

| | |
|------------------------------|------|
| Disclaimer of Warranty | ii |
| Welcome!..... | vii |
| Identifying Your Drive..... | viii |

Chapter1: Introduction

| | |
|--|------|
| Introduction | 1-3 |
| Assessing the System Requirements..... | 1-4 |
| Assessing the Drive Environment..... | 1-4 |
| IMPULSE•VG+ Series 2 General Specifications | 1-6 |
| CDBM & CDBR Units..... | 1-8 |
| Minimum Resistor Ohmic Values | 1-8 |
| Installation/Wiring of CDBR/CDBM Braking Unit..... | 1-13 |
| AC Reactor Specifications | 1-16 |
| Interface Cards Specifications | 1-18 |
| Interface Card Specification | 1-18 |

Chapter 2: Installation

| | |
|---|-----|
| IMPULSE•VG+ Series 2 System Components And External Devices | 2-3 |
| Long Time Storage | 2-6 |
| Installing the Drive | 2-7 |
| IMPULSE•VG+ Series 2 Dimensions/Heat Loss—Open Chassis..... | 2-9 |

Chapter 3:Wiring

| | |
|---|------|
| IMPULSE•VG+ Series 2 Wiring Practices..... | 3-3 |
| IMPULSE•VG+ Series 2 Standard Connection Diagram | 3-5 |
| Suggested Circuit Protection Specifications and Wire Size | 3-6 |
| Power Circuit Wiring Procedures..... | 3-8 |
| Wiring the Control Circuit..... | 3-12 |
| Control Input..... | 3-12 |
| Additional Input Terminals..... | 3-12 |

| | |
|---|------|
| Control Output | 3-12 |
| Control Circuit Terminals..... | 3-13 |
| Control Circuit Wiring Procedures..... | 3-14 |
| Wiring the Encoder Circuit | 3-19 |
| Encoder Circuit Wiring Procedures | 3-19 |
| Encoder Wiring Diagrams and Information | 3-20 |

Chapter 4: Programming Basic Features

| | |
|---------------------------------------|------|
| Overview | 4-3 |
| Checks Before Powering | 4-3 |
| Precautions | 4-3 |
| Using the Keypad..... | 4-4 |
| Keypad LED and Button Functions | 4-5 |
| Parameters..... | 4-6 |
| Parameter Modes | 4-8 |
| Initialization Set-up..... | 4-9 |
| Auto-Tuning | 4-16 |

Chapter 5 : Programming Advanced Features

| | |
|--|------|
| Application | 5-3 |
| Preset Reference | 5-3 |
| Reference Limits | 5-5 |
| Sequence/Reference Source | 5-6 |
| Trim Control Level..... | 5-14 |
| Acceleration/Deceleration | 5-15 |
| Accel/Decel Time Switching Frequency | 5-16 |
| Torque Limit Accel/Decel | 5-18 |
| Phase Loss Detection | 5-19 |
| SVR (Speed Variation Error) | 5-19 |
| Jump Frequencies | 5-20 |
| Special Functions..... | 5-21 |
| Quick Stop™/Reverse Plug Simulation™ | 5-22 |

| | |
|---|-------------|
| Micro-Positioning Control™ | 5-24 |
| Travel Limits | 5-25 |
| Zero Servo | 5-27 |
| Load Check | 5-28 |
| Ultra-Lift | 5-30 |
| Torque Limit | 5-32 |
| No-Load Brake Start/Stop | 5-32 |
| Load Float PG Monitor | 5-35 |
| PG Monitor Count | 5-36 |
| Shaft Oscillation Gain | 5-37 |
| PG Monitor Fault Time | 5-37 |
| Optional Digital Input Set-up (G5IN4 Digital Multi-Function Inputs) | 5-45 |
| Weight Measurement | 5-49 |
| Slack Cable Detection | 5-52 |
| Delay Timers | 5-54 |
| Timer Function | 5-54 |
| Inching Control | 5-55 |
| Tuning | 5-56 |
| DC Injection | 5-56 |
| Automatic Slip Compensation | 5-58 |
| Automatic Speed Regulator (ASR) Tuning | 5-58 |
| Torque Control | 5-59 |
| Speed/Torque Control Switching | 5-61 |
| Droop Control | 5-62 |
| Dwell Function | 5-63 |
| S-Curve Acceleration/Deceleration | 5-64 |
| Carrier Frequency | 5-66 |
| Factory Tuning | 5-67 |
| Motor Parameters | 5-68 |
| Voltage/Frequency Pattern | 5-68 |
| Motor Set-up | 5-70 |
| Motor 2 Method | 5-71 |
| Motor 2 Voltage/Frequency Pattern | 5-71 |

| | |
|--|--------------|
| Motor 2 Set-up | 5-72 |
| Option Parameters | 5-73 |
| Encoder (PG) Option Set-up | 5-73 |
| AI-14 Set-up | 5-75 |
| Digital Input Option Set-up | 5-76 |
| Analog Output Option Set-up | 5-77 |
| DO-02 Digital Output Set-up | 5-78 |
| DO-08 Digital Output Set-up | 5-79 |
| PO-36F Set-up | 5-80 |
| Dual Port Ram | 5-81 |
| Terminal Parameters | 5-82 |
| Digital Inputs | 5-82 |
| Digital Outputs | 5-85 |
| Digital Outputs—Fault Annunciate (H2-01~03=40) | 5-88 |
| External Fault Response Selection | 5-90 |
| Analog Inputs | 5-91 |
| Analog Outputs | 5-93 |
| Serial Communication Set-up | 5-94 |
| Protection Parameters | 5-95 |
| Motor Overload | 5-95 |
| Stall Prevention | 5-96 |
| Reference Detection | 5-98 |
| Torque Detection | 5-100 |
| Hardware Protection | 5-103 |
| Automatic Reset | 5-104 |
| Example: | 5-105 |
| Operator Parameters | 5-106 |
| Monitor Selection | 5-106 |
| Keypad Key Selection | 5-108 |
| Clear History | 5-111 |
| Monitor Parameters | 5-112 |

Chapter 6: Troubleshooting IMPULSE•VG+ Series 2

| | |
|---|------|
| Troubleshooting the Drive | 6-3 |
| Maintenance and Inspection | 6-3 |
| Motor Faults and Corrective Actions | 6-4 |
| Drive Faults and Indicators | 6-4 |
| Troubleshooting Encoder Related Faults | 6-11 |
| Fault Code: Dev–Speed Deviation | 6-11 |
| Fault Code: PGO–Pulse Generator Signal Missing | 6-12 |
| Fault Code: PGO2–Pulse Generator Signal Monitor Fault | 6-13 |
| Fault Code: SVR–Noisy Encoder Fault | 6-14 |
| Fault Code: BE1–Torque Proving Fault | 6-15 |
| Fault Code: BE3–Brake Release Fault | 6-15 |
| Fault Code: BE6–Brake Proving Alarm | 6-16 |
| Fault Code: OC–Over Current Fault | 6-17 |
| Fault Display and Corrective Actions at Auto-tuning | 6-18 |
| Troubleshooting CDBR Faults | 6-19 |
| Power Section Check | 6-20 |
| Power Off Checks | 6-20 |
| Braking Circuit | 6-22 |

Appendix A: Chapter Servicing IMPULSE•VG+ Series 2

| | |
|--|-----|
| Service | A-3 |
| Service Policy For Small Drives, DBUs, and Other Electrical Components | A-3 |
| Service Policy for Large Drives | A-4 |
| Electromotive Systems Limited Warranty | A-5 |
| IMPULSE•VG+ Series 2 Parameter Listing | A-7 |

Appendix B: Chapter Differences in Software Versions

| | |
|---|-----|
| Important Product Upgrade Information | B-3 |
| Changes in Software from 14906 to 14908/14909 | B-3 |
| Changes in Software from 14908/14909 to 14911 | B-4 |
| Changes in Software from 14911 to 14912 | B-6 |

This page intentionally left blank.

Welcome!

IMPULSE•VG+ Series 2 represents the second generation of our high-performance flux vector crane controls. It goes far beyond the scalar (voltage and frequency control) drive designs by having *true torque-control* capabilities. The IMPULSE•VG+ Series 2, which is designed for a closed-loop system, is ideal for hoists without mechanical load brakes and for very high-performance traverse applications.

Incorporating a pulse-width-modulated (PWM), flux vector design, IMPULSE•VG+ Series 2 generates the optimum current waveform, which gives you impressive torque and speed motor control. The drive offers a 1000:1 speed range — compared to a 3:1 range for two-speed motors and a 10:1 range for wound-rotor motors.

Here's a sample of IMPULSE•VG+ Series 2's special features and how they can help you improve your overhead material handling performance:

- Distinct speed control (up to nine speeds) as well as infinitely variable speed control are provided; you can use pendant pushbutton stations, infrared or radio controls, or joysticks.
- An English, plain-language liquid crystal display (2 lines, 16 characters per line) makes programming, troubleshooting, and operating the drive easy.
- Built-in Serial Communication (9600-baud modbus) provides reliable digital linkage among the various crane system peripherals, including our line of PulseStar™ Remote Crane Controls.
- Micro-Positioning Control™ is used to place loads with a high degree of precision, eliminating the need to jog or plug your motors.
- A compact circuit design gives the drive a small footprint.
- Ultra-Lift™ capabilities enhance productivity by allowing the overspeeding of any load less than full load.
- Safe Operating Windows™ prevents you from programming the drive with unsafe parameters.
- Automatic Keypad Lockout™ and a snap-in, removable keypad helps you limit programming access and reduce the possibility of programming errors.
- Load Check™ prevents you from overstressing equipment by attempting to lift a load beyond the capacity of the crane or hoist.
- Weight Measurement enables you to weigh a load with an accuracy of ± 5 percent of full load.
- Phase Loss Detection causes the drive to fault and commands the electric brake to set if an input or output phase loss occurs.
- Quick Stop™ ensures a rapid deceleration to stop once a drive RUN command is removed, reducing the possibility of a crane collision.
- Reverse Plug Simulation™ allows you to change the direction of travel (motor's phase sequence) very rapidly before the electric brake can be set.
- Flash ROM stores the drive system's last four fault occurrences in the drive's memory—even after power-down—for diagnostic purposes.

- Slack Cable Detection identifies slack cable conditions and adjusts outputs to immediately stop lowering.
- Load Float Start & Stop, with the crane fully at rest (without electric brakes set), allows the precise placement of critical loads without rollback or delays because of electric brake operation.
- Motor Changeover Capability allows you to use one inverter for two motors (e.g., main and auxiliary hoists) with different motor characteristics.
- A 120V Control Voltage Interface Card gives you direct access to a 120V user input device (e.g., pendant) without adding electromechanical components.
- Elapsed Time Counter (with fault history) indicates actual operation time, total power-up time, and the elapsed time between fault occurrences.

Identifying Your Drive

If you ever have to contact Electromotive Systems about your drive, first determine the model and serial numbers of your drive by looking at the nameplate shown below.

| | | | | |
|--|--------------------|------------------|--------------------|------------------|
| <i>IMPULSE</i> <i>ELECTROMOTIVE SYSTEMS</i> <i>MILWAUKEE, WISCONSIN</i> | A.C. INPUT | | A.C. OUTPUT | |
| | VOLTS: | PHASE: 3 | VOLTS: | PHASE: 3 |
| | AMPS: | HZ: 50/60 | AMPS: | HZ: 0-400 |
| | SERIAL NO.: | | H.P.: | 1263 |
| MODEL NO.: | | | | |

This nameplate is located on the side of the drive nearest to the keypad.

c h a p t e r **1**

Introduction

This page intentionally left blank.



WARNING

- Do not touch any circuitry components while the main AC power is on. In addition, you must wait until the red “CHARGE” LED is out before performing any service on that unit. (As you look at the face of the circuitry, the “CHARGE” LED is located in the lower right corner of the board.) It may take as long as 10 minutes for the charge on the main DC bus capacitors to drop to a safe level.
- Do not check signals during operation.
- Do not connect the main output terminals (T1, T2, T3) to the incoming, three-phase AC source.
- Do not connect the control board terminals, which are the 27 two-tiered terminals, directly to the 120VAC user input device.
- Before executing Built-In Auto-Tuning, ensure that the motor is disconnected from the drive train and the electric brake is released. If the electric brake cannot be released, you must ensure that the brake is disengaged for the entire tuning process.

The instructions in the next three chapters apply to most IMPULSE•VG+ Series 2 crane, hoist, and monorail applications. However, you need to carefully evaluate your specific situation and ensure that you follow NEC codes and your local wiring practices.

These chapters tell you how to install IMPULSE•VG+ Series 2 and, to some extent, the components that it interconnects. It explains how to: assess the drive’s environment, mount the drive, and wire the drive circuits. It’s important to develop a “plan of attack” for both the mounting and wiring since each task has an effect on the other one. To assist you, “IMPULSE•VG+ Series 2 Wiring Practices” is included.

NOTE: If your IMPULSE•VG+ Series 2 is part of an Electromotive Systems, pre-engineered TCONTROLS® motor control panel, disregard this chapter and turn to Chapter 4.

Introduction

Assessing the System Requirements

You must know how you're going to use the drive before you start installation and wiring. You will need to know your requirements for the following components:

- Speed control method(s)
- Braking method(s)
- Power source voltage, number of phases, and kVA rating
- Power source location
- Wire size
- Grounding location and method

Assessing the Drive Environment

When you choose a location for IMPULSE•VG+ Series 2, perform the following steps:

1. Ensure that a 220V or 230V (-15% to +10%) three-phase power source is available for a 230V-rated drive, and that a 380V, 400V, 415V, 440V, or 460V (-15% to +10%) three-phase power source is available for a 460V-rated drive, and that a 500V, 575V, 600V (-15% to +10%) power source is available for a 575V Drive.
2. Ensure the encoder is supplied with +12VDC.
3. If the amperage requirement is greater than 200 mA, provide an auxiliary power supply to the encoder.
4. Ensure that the drive-to-motor wiring distance is less than 250 ft. unless appropriate reactors and/or filters are used.
5. If required, install reactors.

When connecting a drive (230V/460V/575V, Model 2033-FVG+/4034-FVG+/FVG+5032V and smaller) to a large-capacity power supply transformer (500kVA or greater or more than 10 times the inverter kVA rating), or when switching a phase-advancing capacitor, excessive peak current can flow through the input power supply circuit. To prevent damage to the rectifier section in such cases, install a DC reactor between drive Terminals 1 and 2, or an AC reactor on the input side. Installing reactors also improves the power factor on the power supply side.

6. Ensure that the encoder wiring is less than 300 feet, unless fiber optic cables are used.
7. Ensure that the encoder wiring is isolated from the power wiring.
8. Ensure that the encoder wiring shield is grounded at only one end (PG-X2 TA3).
9. Ensure that the drive circuit wiring is protected or isolated from:
 - Ambient temperatures outside the range of +14° F to +113° F (-10° C to +45° C). (Consult Electromotive Systems if you must exceed this temperature range.)
 - Rain or moisture
 - Corrosive gases or liquids
 - Direct sunlight
 - Severe mechanical vibration
10. Ensure that the drive is housed in an appropriate NEMA-rated enclosure.

11. For severe-duty applications (for example—long lifts) or with 75-Up-or-greater motors, ensure that the drive control system is adequately cooled, even though the ambient temperature limit is not exceeded. For more information, contact Electromotive Systems.

IMPULSE•VG+ Series 2 General Specifications

230V Class

| Specification | Specification Values and Information for Each 230V-Class Model (####-FVG+) | | | | | | | | | | | | |
|-------------------|--|------|------|------|------|------|------|------|------|------|------|------|------|
| | 2006 | 2008 | 2011 | 2017 | 2025 | 2033 | 2054 | 2068 | 2080 | 2130 | 2160 | 2224 | 2300 |
| Rated current (A) | 6 | 8 | 11 | 17.5 | 25 | 33 | 49 | 64 | 80 | 130 | 160 | 224 | 300 |
| Capacity (kVA) | 2.3 | 3.0 | 4.2 | 6.7 | 9.5 | 13 | 19 | 20 | 25 | 50 | 61 | 85 | 110 |

460V Class

| Specification | Specification Values and Information for Each 460V-Class Model (####-FVG+) | | | | | | | | | | | | | | | | | | | |
|-------------------|--|------|------|------|------|------|------|------|------|------|------|------|------|------|------|------|------|------|------|------|
| | 4001 | 4003 | 4005 | 4008 | 4011 | 4014 | 4021 | 4028 | 4034 | 4041 | 4052 | 4065 | 4080 | 4096 | 4128 | 4165 | 4224 | 4302 | 4450 | 4605 |
| Rated current (A) | 1.8 | 3.4 | 4.8 | 8 | 11 | 14 | 21 | 27 | 34 | 41 | 52 | 65 | 80 | 96 | 128 | 165 | 224 | 302 | 450 | 605 |
| Capacity (kVA) | 1.4 | 2.6 | 3.7 | 6.1 | 8.4 | 11 | 16 | 21 | 26 | 31 | 40 | 50 | 61 | 73 | 98 | 130 | 170 | 230 | 340 | 460 |

575V Class

| Specification | Specification Values and Information for Each 460V-Class Model (####-FVG+) | | | | | | | | | | | | | | | | | | |
|-------------------|--|------|------|------|------|------|------|------|------|------|------|------|------|------|------|------|------|--|--|
| | 5003 | 5004 | 5006 | 5009 | 5012 | 5017 | 5022 | 5027 | 5032 | 5041 | 5052 | 5062 | 5077 | 5099 | 5130 | 5172 | 5200 | | |
| Rated current (A) | 3.5 | 4.1 | 6.3 | 9.8 | 12.5 | 17 | 22 | 27 | 32 | 41 | 52 | 62 | 77 | 99 | 130 | 172 | 200 | | |
| Capacity (kVA) | 2 | 3 | 5 | 7.5 | 10 | 15 | 20 | 25 | 30 | 40 | 50 | 60 | 75 | 100 | 125 | 150 | 200 | | |

230V, 460V and 575V Classes

| Specification | Specification Value and Information for All Models |
|---------------------------------------|---|
| Certification | UL, CUL, CSA |
| Rated input power supply volts & freq | 3-phase 200/208/220/230V or 300/400/415/440/460V or 500/575/600V |
| Allowable input voltage fluctuation | +10% or -15% of nominal |
| Allowable input frequency fluctuation | ±5% of nominal |
| Control method | Fully digital, flux vector control; sine-wave, pulse-width-modulated |
| Maximum output voltage (VAC) | Max output voltage 3-phase, 200/208/220/230V; 380/400/415/440/460V; 500/575/600V (proportional to input voltage). |
| Rated frequency (Hz) | Up to twice motor nameplate RPM (Ultra-Lift) 150 Hz max |
| Output speed control range | 1000:1 |
| Output frequency accuracy | .01%—with digital reference command .1%—with analog reference command; 10 bits/10V |
| Frequency reference resolution | Digital: .01 Hz; analog: .03 Hz (at 60 Hz) |
| Output frequency resolution | .01 Hz |
| Overload capacity | 150% of rated load for 1 min |
| Remote frequency reference sources | 0–10VDC (20kΩ); 4–20mA (250Ω); ±10VDC (optional); serial (optional) |
| Accel/decel times | 0.1 to 25.5 sec—2 sets; 4 parameters are independently adjustable |

| Specification | Specification Value and Information for All Models |
|------------------------------------|---|
| Braking torque | Approximately 120% if motor and inverter are sized 1:1; 150% or more with dynamic braking (optional) |
| Motor overload protection | Electronic thermal overload relay; field-programmable |
| Overcurrent protection level (OC1) | 200% of rated current |
| Circuit protection | Ground fault and blown-fuse protection |
| Overvoltage protection level | 400/800/1000VDC |
| Undervoltage protection level | 190/380/546VDC |
| Heatsink overtemperature | Thermostat trips at 105° C |
| Torque limit selection | Separate functions for FORWARD, REVERSE, REGEN.; all selectable from 0–300%) |
| Stall prevention | Separate functions for accel, decel, at-speed, and constant horsepower region |
| Other protection features | Speed deviation, overspeed, mechanical brake failure, lost output phase, failed-oscillator, PG-disconnect, mechanical overload, and roll-back detection |
| DC bus voltage indication | Charge LED is on until DC bus voltage drops below 50VDC |
| Location | Indoors; requires protection from moisture, corrosive gases, and liquids |
| Ambient operating temperature | 14° to 113° F (-10° to 45° C) for open chassis |
| Storage temperature | -4° to 140° F (-20° to 60° C) |
| Humidity | 90% relative; noncondensing |
| Vibration | 1 G less than 20 Hz; 0.2 G for 20–50 Hz |
| Elevation | 3300 Ft. (1000M) or less |

CDBM & CDBR Units

The CDBM and CDBR are designed to pass regenerative energy from an inverter’s DC bus to a resistor bank. The CDBM/CDBR operate when the voltage on the DC bus reaches a specific level which turns on an internal transistor. This transistor stays on until the DC bus voltage drops to an appropriate level. The difference between the turn on and the turn off voltage is the hysteresis voltage.

The CDBM/CDBR, and its associated dynamic braking resistor, are used to help the inverter decelerate AC motors (dynamic braking) and to provide a path for motor regenerative energy under over hauling conditions, such as on a hoist.

Minimum Resistor Ohmic Values

The following chart should be used to determine minimum ohmic values for dynamic braking resistors for different supply voltages.

| | | Minimum Ohmic Value for Braking Resistor | | | | | | | |
|----------------|-----------------|--|------------|-----------|------------|------------|-----------|-----------|-----------|
| Supply Voltage | Turn On Voltage | CDBM-2015 | CDBM-2022 | CDBM-4030 | CDBM-4045 | CDBM-4090 | CDBM-4220 | CDBM-5037 | |
| | | CDBR-2015B | CDBR-2022B | CDBR-2110 | CDBR-4030B | CDBR-4045B | CDBR-4090 | CDBR-4220 | CDBR-5037 |
| 200V | 330V | 8.3 | 5.5 | 1.3 | — | — | — | — | |
| 208V | 345V | 8.6 | 5.8 | 1.4 | — | — | — | — | |
| 220V | 365V | 9.1 | 6.1 | 1.5 | — | — | — | — | |
| 230V | 380V | 9.5 | 6.3 | 1.5 | — | — | — | — | |
| 380V | 630V | — | — | — | 15.8 | 10.5 | 6.3 | 2.5 | |
| 400V | 660V | — | — | — | 16.5 | 11.0 | 6.6 | 2.6 | |
| 415V | 690V | — | — | — | 17.3 | 11.5 | 6.9 | 2.8 | |
| 440V | 730V | — | — | — | 18.3 | 12.2 | 7.3 | 2.9 | |
| 460V | 760V | — | — | — | 19.0 | 12.7 | 7.6 | 3.0 | |
| 500 | 825V | — | — | — | — | — | — | 20.6 | |
| 575 | 950V | — | — | — | — | — | — | 23.8 | |

CDBM & CDBR Braking Unit Specification

| Braking Unit Model | | 200V to 300V | | | 308V to 460V | | | | 500V to 575V |
|---------------------------------|--|---|------------|--------------|--|------------|-------------|--------------|---------------------------------|
| | | 2015 | 2022 | — | 4030 | 4045 | 4090 | 4220 | 5037 |
| CDBM | | 2015B | 2022B | 2110 | 4030B | 4045B | 4090 | 4220 | 5037 |
| Applicable Motor Output HP (kW) | | 20 (15) | 30 (22) | 150 (110) | 40 (30) | 60 (45) | 120 (90) | 300 (220) | 57 (37) |
| Output Characteristics | Max. Discharge Current (A (peak value))* | 40 | 60 | 250 | 40 | 60 | 100 | 250 | 40 |
| | Rated Discharge Current (A) | 15 | 20 | 80 | 15 | 18 | 30 | 80 | 15 |
| | Braking Start Voltage | 330/345/365/380V ±3V | | | 630/660/690/730/760V ±6V | | | | 825V/950V ±8V |
| | Max. Hysteresis Error | Approx. 8V | | | Approx. 16V | | | | Approx. 20V |
| Power Supply | VDC | 243 (1.35 x 200 x 0.9) to 400V peak | | | 460 (1.35 x 380 x 0.9) to 800V peak | | | | 607 (1.35 x 500 x 0.9) to 1000V |
| | VAC† | — Single phase 200 to 220V 50Hz 200 to 230V 60Hz | | | — Single phase 380 to 460V 50Hz/ 60Hz | | | | — |
| Protective Functions | Fin Overheat | Thermostat | | | | | | | |
| | Power Charge Indication | Charge lamp stays ON until bus voltage drops below 50V. | | | | | | | |
| Environmental Conditions | Location | Indoor (protected from corrosive gases and dust) | | | | | | | |
| | Ambient Temperature | +14° to 104°F (-10° to +40°C) (not frozen) | | | | | | | |
| | Storage Temperature | -4° to +140°F (-20° to +60°C) | | | | | | | |
| | Humidity | 90%RH (non-condensing) | | | | | | | |
| | Vibration | 1G at less than 20Hz, up to 0.2G at 20 to 50 Hz | | | | | | | |
| Protective Configuration | | Wall-mounted enclosed type | | | | | | | |
| Heat Loss (W) | | 32 | 38 | 129 | 54 | 59 | 94 | 135 | 70 |

* Loading time rate can be used below 10% ED (max. 10 min.)

† AC power supply for cooling fan is used only for models CDBR-2110 and CDBR-4220.

CDBM Braking Unit Dimensions

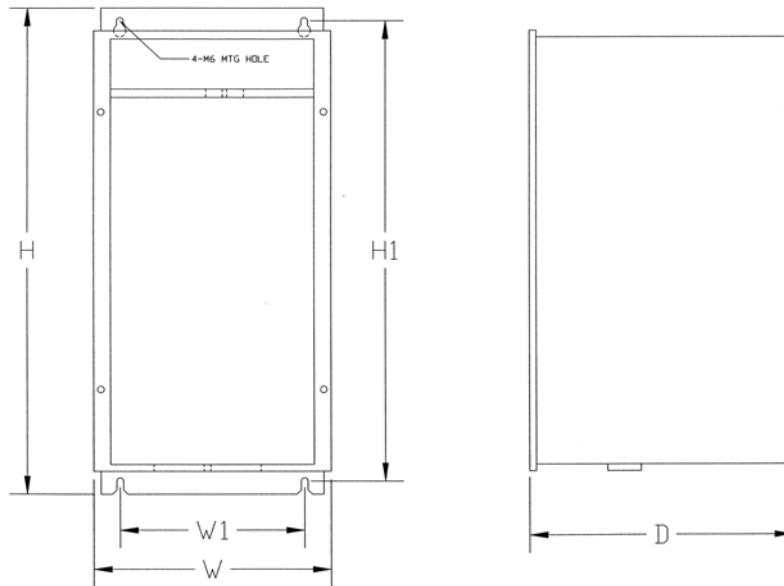

Figure 1-1: CDBM Dimensions

| Model Number | Dimensions in inches (mm) | | | | | |
|--------------|---------------------------|---------|-------|----------|-------|------|
| | Overall | | | Mounting | | |
| | W | H | D | W1 | H1 | d |
| CDBM-2015 | | | | | | |
| CDBM-2022 | 5.53 | 11.0 | 5.91 | 3.94 | 10.24 | |
| CDBM-4030 | (140.5) | (279.5) | (150) | (100) | (260) | |
| CDBM-4045 | | | | | | |
| CDBM-4090 | 8.50 | 14.50 | 5.94 | 7.09 | 13.98 | 0.24 |
| | (216) | (368) | (151) | (180) | (355) | (6) |
| CDBM-4220 | 10.63 | 14.50 | 7.25 | 8.27 | 13.98 | |
| | (270) | (368) | (184) | (210) | (355) | |
| CDBM-5037 | 5.53 | 11.0 | 5.91 | 3.94 | 10.24 | |
| | (140.5) | (279.5) | (150) | (100) | (260) | |

CDBR-B Braking Unit Dimensions

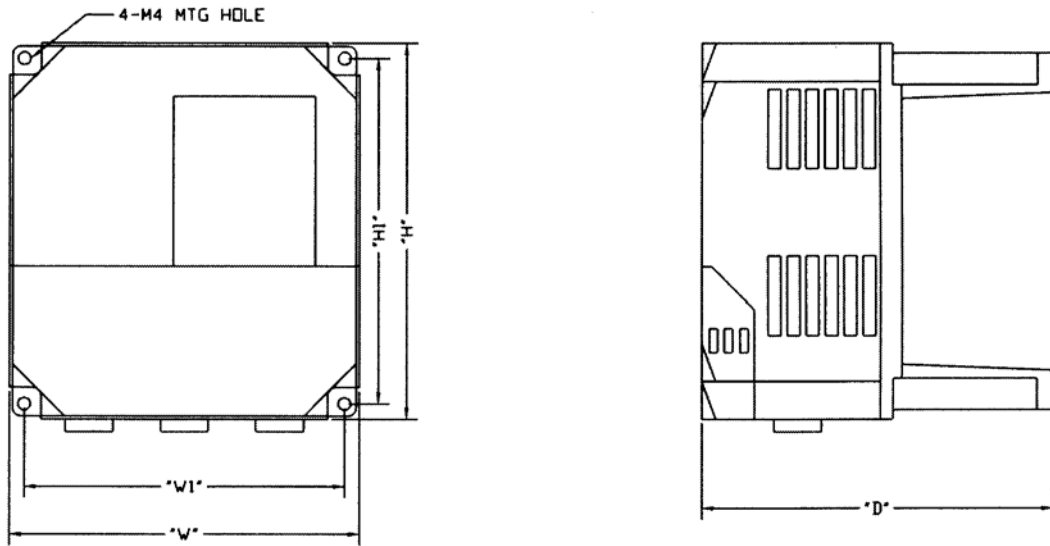

Figure 1-2: CDBR-B Dimensions

| Model Number | Dimensions in inches (mm) | | | | | | Wt. in lbs. (kg) |
|--------------|---------------------------|-------|---------|----------|-------|-----|---------------------|
| | Overall | | | Mounting | | | |
| | W | H | D | W1 | H1 | d | |
| CDBR-2015B | | | | | | | |
| CDBR-2022B | 5.51 | 5.91 | 5.45 | 5.04 | 5.43 | .16 | |
| CDBR-4030B | (140) | (150) | (138.5) | (128) | (138) | (4) | 7.79 |
| CDBR-4045B | | | | | | | (3.54) |

CDBR Braking Unit Dimensions

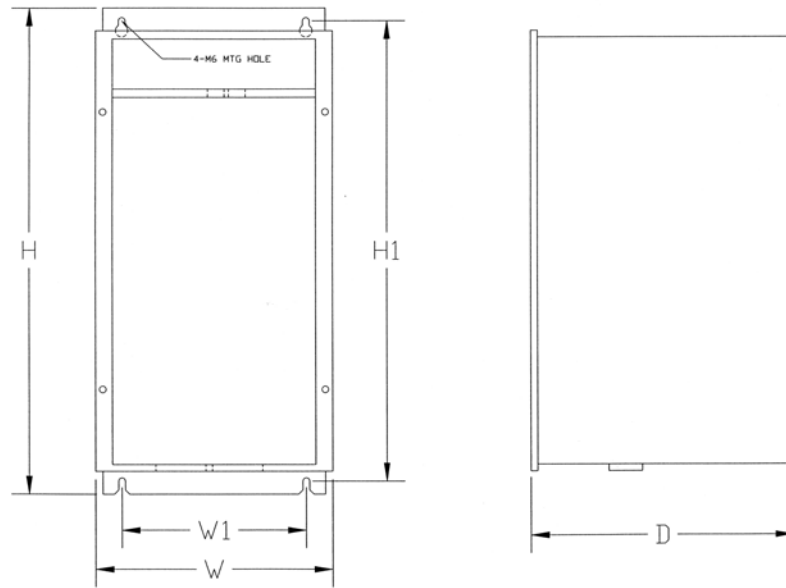

Figure 1-3: CDBR Dimensions

| Model Number | Dimensions in inches (mm) | | | | | |
|--------------|---------------------------|----------------|---------------|---------------|----------------|-------------|
| | Overall | | | Mounting | | |
| | W | H | D | W1 | H1 | d |
| CDBR-2110 | 7.09 (180) | 14.57 (370) | 7.87 (200) | 5.51 (140) | 13.78 (350) | |
| CDBR-4090 | 8.66 (220) | 14.76 (375) | 7.87 (200) | 7.09 (180) | 13.98 (355) | 0.24 (6) |
| CDBR-4220 | 9.84 (250) | 14.76 (375) | 7.87 (200) | 8.27 (210) | 13.98 (355) | |
| CDBR-5037 | 5.51 (140) | 11.02 (280) | 6.29 (160) | 3.94 (100) | 10.23 (260) | |

Installation/Wiring of CDBR/CDBM Braking Unit



WARNING

120 VAC is not needed for the control circuit to operate. If 120 VAC is applied to terminals 1, 2, 5 or 6, DAMAGE TO THE UNIT WILL RESULT.

NOTE:

- Some Braking units have only a symbol labeling the terminal.
- Most resistors do not have P_0 (r_0) and B (S_0) designators.
- Polarity does not matter on the resistor.

1. Wire N (S) on the CDBR/CDBM to N (S) on the drive.
2. Wire P (r) on the CDBR/CDBM to P(r) on the drive.
3. Wire the P_0 (r_0) on the CDBR/CDBM to the dynamic braking resistor.
4. Wire B (S_0) on the CDBR/CDBM to the dynamic braking resistor.
5. CDBR model #4220 has an internal fan. It requires terminals r and s to be wired to one phase of the 460V line voltage in order to power the fan.
6. Terminals 3 and 4 are the Cooling Fin Overheat Contact.
Thermoswitch contact rating: 250VAC, 1A max
30VDC, 1A max
7. Terminals 1, 2, 5 and 6 are used for **MASTER/SLAVE** Operation. Use twisted-pair wires of 14 AWG or smaller for connection between 5, 6, and 1, 2 on the braking units. Parallel connection is possible up to a maximum of 10 units. Refer to Figure 1-4 (page 1-14) for parallel connection of braking units.
8. Set the Voltage Selection Jumper to match the voltage of the incoming power source.
9. Set the Master/Slave Jumper to Master for single unit operation.
10. For further information, refer to CDBR/CDBM manual.

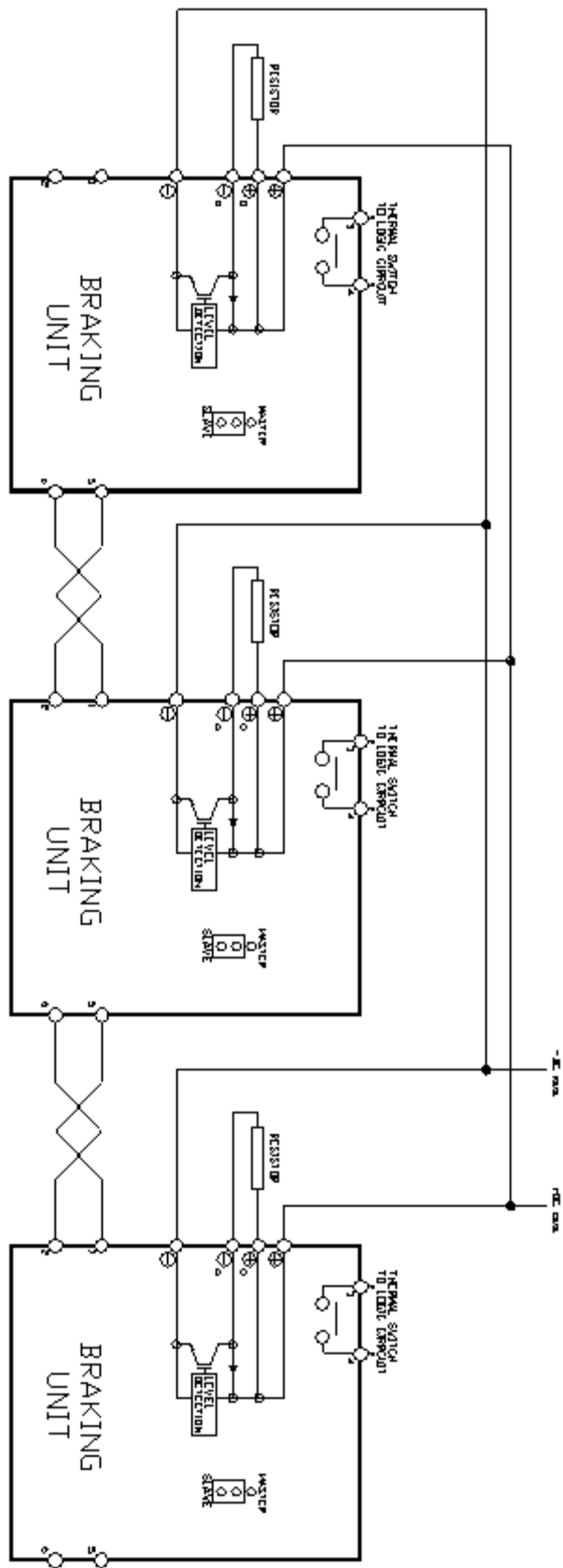

Figure 1-4: CDBR-B Parallel connection of Braking Unit

AC Reactor Specifications

Reactors, both as input (line) and output (load) devices, protect adjustable frequency drives, motors, and other load devices against excessive voltage and current.

The following guidelines may help determine input and output reactor requirements:

- Install an input reactor if the power source is greater than 500kVA.
- Install an output reactor if the distance between the drive and the motor exceeds 150 feet.
- Install an output reactor if a device, such as a power limit switch, is used to disconnect the motor from the drive.
- Install one output reactor per drive for a multiple-drive arrangement requiring reactor protection.
- For a multiple drive arrangement, an input reactor for each drive is recommended for optimal protection. However, if the drives are within two drive sizes of each other, a single input reactor can be used. The reactor must be rated at an amperage equal to or greater than the sum of the amperage for all the drives.

230V Class

| Model Number | 230V Part Number | Maximum Amps of Reactor |
|--------------|------------------|-------------------------|
| 2006-FVG+ | REA230-2 | 8 |
| 2008-FVG+ | REA230-2 | 8 |
| 2011-FVG+ | REA230-3 | 12 |
| 2017-FVG+ | REA230-5 | 18 |
| 2025-FVG- | REA230-7.5 | 25 |
| 2033-FVG+ | REA230-10 | 35 |
| 2054-FVG+ | REA230-20 | 55 |
| 2068-FVG+ | REA230-25 | 80 |
| 2080-FVG+ | REA230-30 | 80 |
| 2130-FVG+ | REA230-50 | 130 |
| 2160-FVG+ | REA230-60 | 160 |
| 2224-FVG+ | REA230-100 | 250 |
| 2300-FVG+ | REA230-125 | 320 |

460V Class

| Model Number | 460 V Part Number | Maximum Amps of Reactor |
|--------------|-------------------|-------------------------|
| 4001-FVG+ | REA460-1 | 2 |
| 4003-FVG+ | REA460-2 | 4 |
| 4005-FVG+ | REA460-5 | 8 |
| 4008-FVG+ | REA460-5 | 8 |
| 4011-FVG+ | REA460-7.5 | 12 |
| 4014-FVG+ | REA460-10 | 18 |
| 4021-FVG+ | REA460-15 | 25 |
| 4028-FVG+ | REA460-20 | 35 |
| 4034-FVG+ | REA460-25 | 35 |
| 4041-FVG+ | REA460-30 | 45 |
| 4052-FVG+ | REA460-40 | 55 |
| 4065-FVG+ | REA460-50 | 80 |
| 4080-FVG+ | REA460-60 | 80 |
| 4096-FVG+ | REA460-75 | 100 |
| 4128-FVG+ | REA460-100 | 130 |
| 4165-FVG+ | REA460-150 | 200 |
| 4224-FVG+ | REA460-200 | 250 |
| 4302-FVG+ | REA460-250 | 320 |
| 4450-FVG+ | REA460-400 | 500 |
| 4605-FVG+ | REA460-500 | 600 |

575V Class

| Model Number | 575V Part Number | Maximum Amps of Reactor |
|--------------|------------------|-------------------------|
| 5003-FVG+ | REA575-2 & 3 | 4 |
| 5004-FVG+ | REA575-2 & 3 | 4 |
| 5006-FVG+ | REA575-5 | 8 |
| 5009-FVG+ | REA575-10 | 12 |
| 5012-FVG+ | REA575-10 | 12 |
| 5017-FVG+ | REA575-15 | 18 |
| 5022-FVG+ | REA575-20 & 25 | 25 |
| 5032-FVG+ | REA575-30 | 35 |
| 5041-FVG+ | REA575-40 | 45 |
| 5052-FVG+ | REA575-50 | 55 |
| 5062-FVG+ | REA575-60 & 75 | 80 |
| 5077-FVG+ | REA575-60 & 75 | 80 |
| 5099-FVG+ | REA575-100 | 100 |
| 5130-FVG+ | REA575-150 | 160 |
| 5172-FVG+ | REA575-200 | 200 |
| 5200-FVG+ | REA575-200 | 200 |

Interface Cards Specifications

IMPULSE•VG+ Series 2 is designed to interface directly with 120VAC user input and output devices via G5IF, G5IN4, and G5OUT. This eliminates the need for an additional interface relay or isolation circuitry.

G5IF has eight optically isolated drive terminals which can be used to connect with the user input device. The Terminal 1 and 2 are always used for the directional run commands (Forward and Reverse, Up and Down). The rest of six terminals are multi-function terminals, and are used for speed control and other characteristics. With multi-function terminals you can assign various functions and performance characteristics without having to rewire the drive.

G5OUT has two 240VAC, 1.5 Amp solid state relays for output indication devices. It includes two programmable multi-function output terminals.

G5IN4 card has four additional input terminals, which can have a total of 14 sets of input selections. The individual terminals can be enabled/disabled within a set. For program information refer to Chapter 5, Programming Advanced Features.

Interface Card Specification

| Model Number | Rated Input Voltage (AC) | Rated Maximum Current |
|---------------------|---------------------------------|------------------------------|
| G5IF | 120V | 1.5 Amp |
| G5OUT | 240V | 1.5 Amp |
| G5IN4 | 120V | 1.5 Amp |

This page intentionally left blank.

c h a p t e r **2**

Installation

This page intentionally left blank.



WARNING

- When preparing to mount the IMPULSE•VG+ Series 2 drive, lift it by its base. Never lift it by the front cover.
- Mount the drive on nonflammable material.
- The IMPULSE•VG+ Series 2 drive generates heat. For the most effective cooling possible, mount it vertically. For more details, refer to the “IMPULSE•VG+ Series 2 Dimensions/ Heat Loss—Open Chassis” pages 2-9 through 2-11.
- When mounting units in an enclosure, install a fan or other cooling device to keep the enclosure temperature below 113°F (45°C).

Failure to observe these Warnings may result in equipment damage.

This chapter explains the following:

1. Choosing a location
2. IMPULSE•VG+ Series 2 components and external devices
3. Drive environment
4. Drive installation

In addition, this section will cover information on the components that interconnect with IMPULSE•VG+ Series 2.

Choosing a Location

Be sure that the drive is mounted in a location protected against the following conditions:

- Extreme cold and heat. Use only within the ambient temperature range:
Open Chassis: +14 to 113°F (-10 to 45°C)
- Direct sunlight (not for use outdoors)
- Rain, moisture
- High humidity
- Oil sprays, splashes
- Salt spray
- Dust or metallic particles in the air
- Corrosive gases (e.g. sulfurized gas or liquids)
- Radioactive substances
- Combustibles (e.g. thinner, solvents, etc.)
- Physical shock, vibration
- Magnetic noise (e.g. welding machines, power devices, etc.)

IMPULSE•VG+ Series 2 System Components And External Devices

Standard IMPULSE•VG+ Series 2 Drive Components

- G5IF 120V Control Voltage Interface Card
- G5OUT Control Output Card

Optional Drive Components

- G5IN4 Control Input Card
- D0-08 Control Output Board
- D0-02 Control Output Relay Board
- AI-14B Analog Input Card
- PO-36F Pulse Output Card

As-Required Drive Components

- AC reactor—line or load
- DC bus reactor
- External dynamic braking resistor(s) (See “Installation/Wiring of CDBR/CDBM Braking Unit” in Chapter 1, page 1-13.)
- External dynamic braking unit

Required External Devices

- Motor
- User input device (pendant, joystick, PC, PLC, radio, or infrared control)
- External circuit protection devices (fuses or circuit breakers) (See “Suggested Circuit Protection Specifications and Wire Size in Chapter 3, page 3-6.)
- R-C surge suppressors on contactor coils

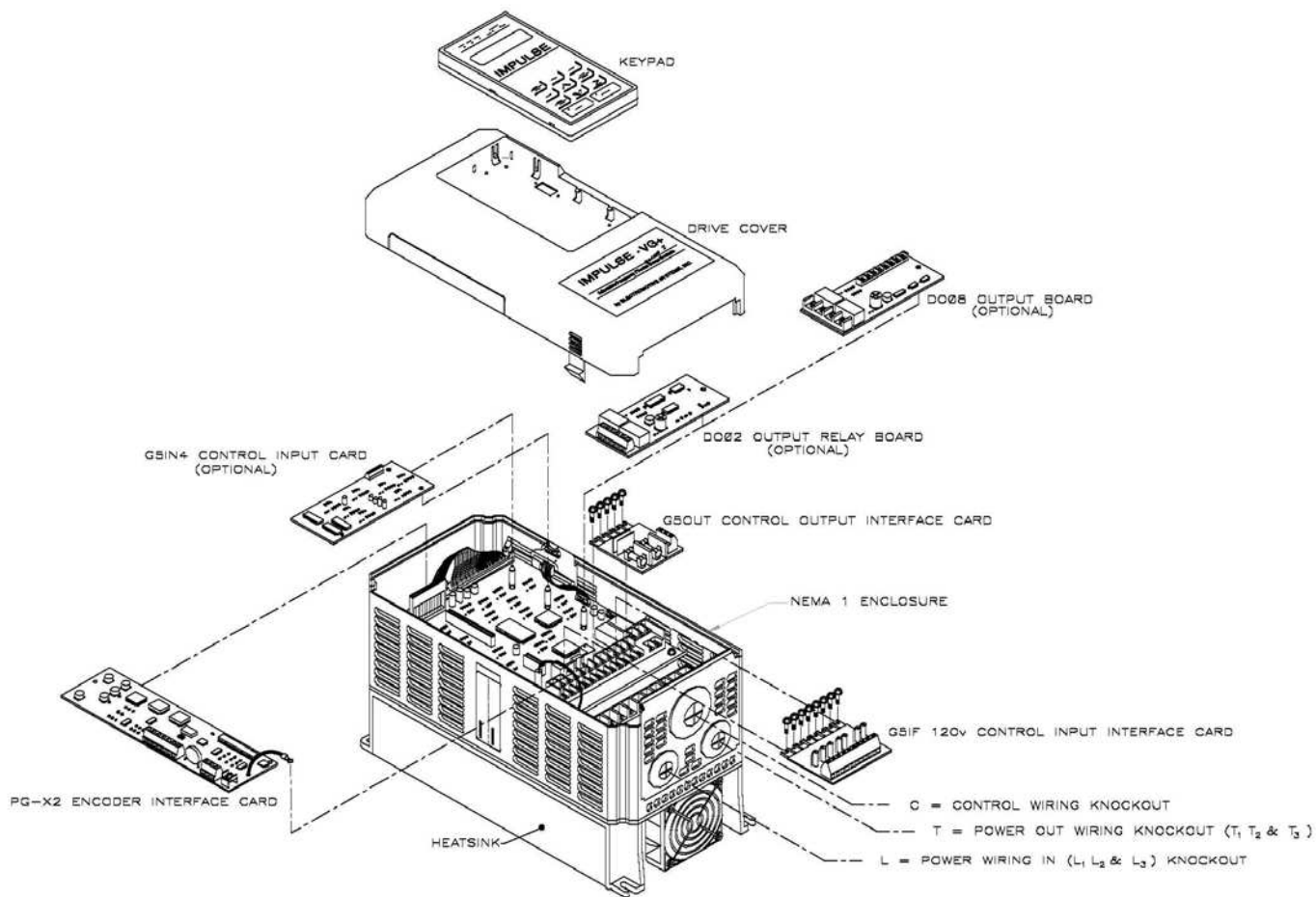

Figure 2-1: IMPULSE•VG+ Series 2 Components Diagram Installing the Drive

Long Time Storage

When an inverter stored for six months or more without operation, reforming of the main circuit electrolytic capacitor is required.

NOTE: If the procedure is not feasible, the drive may be powered up every six months using rated line voltage.

Execute the reforming as follows:

1. Connect a single or three phase variable AC supply to the inverter input terminals L1-L3.
2. Increase the voltage linearly to the rated input voltage for a period of three minutes.
3. Apply rated input voltage for 30-60 minutes or longer.

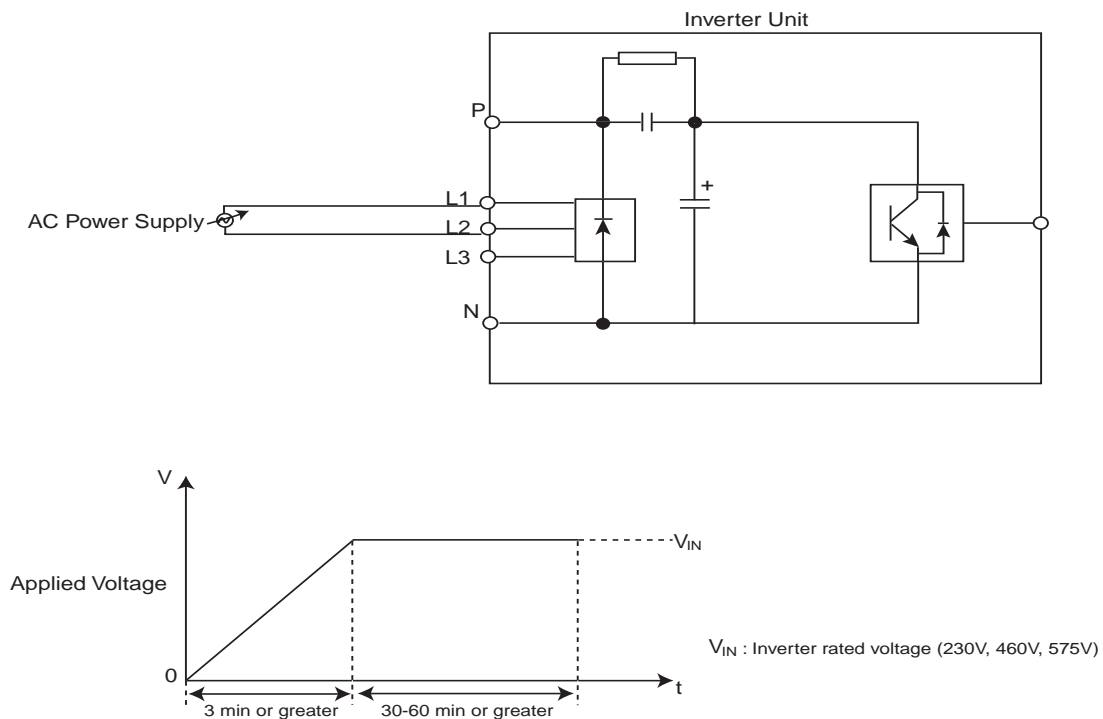

Figure 2-2: Long Time Storage

Installing the Drive

To install IMPULSE•VG+ Series 2:

1. Ensure the drive will be used in a proper environment. Refer to page 1-4.
2. Review “IMPULSE•VG+ Series 2 Components Diagram” on page 2-5 and “IMPULSE•VG+ Series 2 Terminal Diagram” on page 3-5.
3. Determine the sizes and connection locations for the drive components and external devices that need to be wired. Locate the ground. For exact dimensions, see pages 2-9 through 2-11.
4. Determine the position of the subpanel.
5. Ensure that the drive is positioned vertically so that the heat can dissipate properly.
6. Ensure that the air can flow freely around the heat sink as shown below in Figure 2-3.

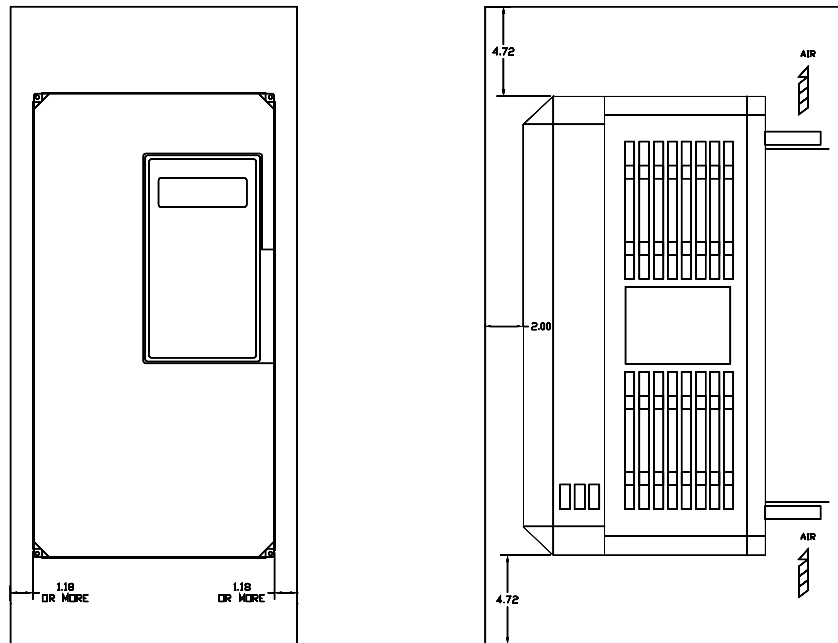

Figure 2-3

NOTE:

- *The recommended clearances at the top, bottom, and both sides of the inverter are the same for both open chassis and NEMA 1 enclosures.*
- *Allowable intake air temperature: 14°F to 104°F (-10°C to +40°C)*
- *If necessary, a heater or air conditioner must be used to maintain the temperature range listed above.*

7. Lay out the wire runs. Size the wire according to NEC Table 610-14(a). At a minimum, use #16 AWG for control wiring and #12 AWG for power wiring. When performing this step:
 - Ensure that the drive control circuit and power circuit wires are perpendicular to each other at any point they cross.
 - Keep power and control festoon wiring in separate cables.
 - Separate control drive circuit and power circuit wiring on the terminal block strip.
8. Obtain the appropriate hardware for mounting.
9. Mount the subpanel or surface to which you are mounting the drive. (Contact Electromotive Systems if you need advice on mounting, especially for larger drives.)
10. Fasten the drive and components to the subpanel.
11. Remove the keypad from the front cover by pushing the depression area and lifting the keypad as shown below in Figure 2-4.

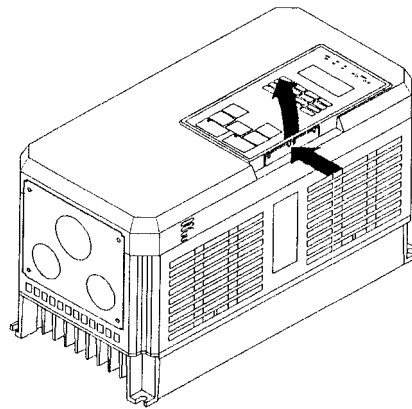

Figure 2-4

12. Remove the drive cover. For Models 2003-FVG+ through 2033-FVG+ and 4001-FVG+ through 4014-FVG+ and 5003-FVG+ through 5022-FVG+. See Figure 2-5. On larger size drives, the cover is attached with screws.

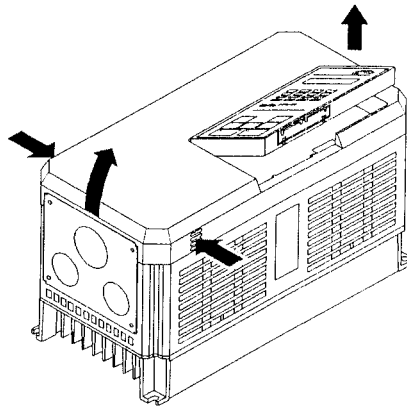

Figure 2-5

13. Remove the G5OUT Card (if used).
14. Remove the G5IF Card.
15. Follow the wiring practices outlined in Chapter 3.

IMPULSE•VG+ Series 2 Dimensions/Heat Loss—Open Chassis

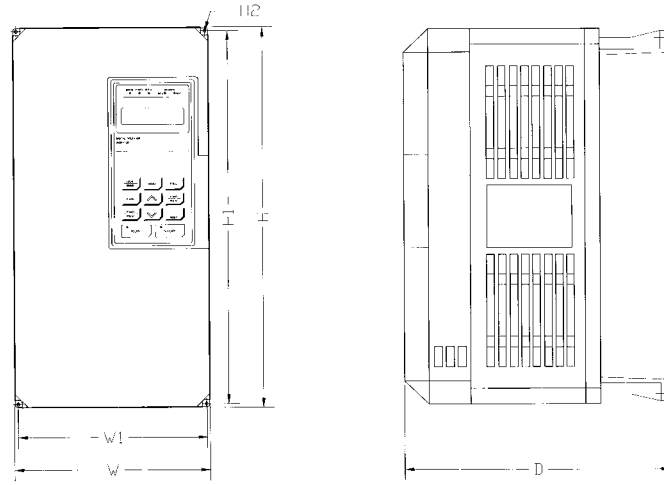

Figure 2-6: Open Chassis

NOTE: Some models are shipped with metal enclosures that can be removed and discarded.

230V Class

| Model | Overall Dimensions in inches and (mm) | | | Mounting Dimensions in inches and (mm) | | | Wt Lbs/(kg) | Heat Loss (W) |
|-----------|--|----------------|----------------|---|----------------|----------------|--------------|------------------|
| | W | H | D | W1 | H1 | H2 | | Total |
| 2006-FVG+ | 5.51 (140) | 11.02 (280) | 6.30 (160) | 4.95 (126) | 10.47 (266) | 0.28 (7) | 6.5 (3) | 90 |
| 2008-FVG+ | 5.51 (140) | 11.02 (280) | 6.30 (160) | 4.95 (126) | 10.47 (266) | 0.28 (7) | 6.5 (3) | 120 |
| 2011-FVG+ | 5.51 (140) | 11.02 (280) | 7.09 (180) | 4.95 (126) | 10.47 (266) | 0.28 (7) | 10 (4.5) | 140 |
| 2017-FVG+ | 5.51 (140) | 11.02 (280) | 7.09 (180) | 4.95 (126) | 10.47 (266) | 0.28 (7) | 10 (4.5) | 215 |
| 2025-FVG+ | 7.87 (200) | 11.81 (300) | 8.07 (205) | 7.32 (186) | 11.22 (285) | 0.31 (8) | 12 (5.5) | 300 |
| 2033-FVG+ | 7.87 (200) | 11.81 (300) | 8.07 (205) | 7.32 (186) | 11.22 (285) | 0.31 (8) | 13 (6) | 345 |
| 2054-FVG+ | 9.84 (250) | 14.96 (380) | 8.86 (225) | 9.29 (236) | 14.37 (365) | 0.30 (7.62) | 24 (10.8) | 585 |
| 2068-FVG+ | 9.84 (250) | 14.96 (380) | 8.86 (225) | 9.29 (236) | 14.37 (365) | 0.30 (7.62) | 24 (10.8) | 725 |
| 2080-FVG+ | 12.80 (325) | 17.72 (450) | 11.22 (285) | 10.83 (275) | 17.13 (435) | 0.30 (7.62) | 62 (28) | 885 |
| 2130-FVG+ | 16.73 (425) | 26.57 (675) | 13.78 (350) | 12.60 (320) | 25.59 (650) | 0.49 (12.5) | 134 (61) | 1370 |
| 2160-FVG+ | 16.73 (425) | 26.57 (675) | 13.78 (350) | 12.60 (320) | 25.59 (650) | 0.49 (12.5) | 137 (62) | 1730 |
| 2224-FVG+ | 18.70 (475) | 31.50 (800) | 13.78 (350) | 14.57 (370) | 30.51 (775) | 0.49 (12.5) | 176 (80) | 2630 |
| 2300-FVG+ | 22.64 (575) | 36.42 (925) | 15.75 (400) | 17.52 (445) | 35.24 (895) | 0.59 (15) | 298 (135) | 3210 |

460V Class

| Model | Overall Dimensions—in. & (mm) | | | Mounting Dimensions—in. & (mm) | | | Wt Lbs/(kg) | Heat Loss (W) |
|-----------|-------------------------------|-----------------|----------------|--------------------------------|-----------------|----------------|--------------|---------------|
| | W | H | D | W1 | H1 | H2 | | Total |
| 4001-FVG+ | 5.51 (140) | 11.02 (280) | 6.30 (160) | 4.95 (126) | 10.47 (266) | 0.28 (7) | 6.5 (3) | 60 |
| 4003-FVG+ | 5.51 (140) | 11.02 (280) | 6.30 (160) | 4.95 (126) | 10.47 (266) | 0.28 (7) | 6.5 (3) | 85 |
| 4005-FVG+ | 5.51 (140) | 11.02 (280) | 7.09 (180) | 4.95 (126) | 10.47 (266) | 0.28 (7) | 8.8 (4) | 110 |
| 4008-FVG+ | 5.51 (140) | 11.02 (280) | 7.09 (180) | 4.95 (126) | 10.47 (266) | 0.28 (7) | 10 (4.5) | 145 |
| 4011-FVG+ | 5.51 (140) | 11.02 (280) | 7.09 (180) | 4.95 (126) | 10.47 (266) | 0.28 (7) | 10 (4.5) | 200 |
| 4014-FVG+ | 7.87 (200) | 11.81 (300) | 8.07 (205) | 7.32 (186) | 11.22 (285) | 0.31 (8) | 13 (6) | 220 |
| 4021-FVG+ | 7.87 (200) | 11.81 (300) | 8.07 (205) | 7.32 (186) | 11.22 (285) | 0.31 (8) | 13 (6) | 360 |
| 4028-FVG+ | 9.84 (250) | 14.96 (380) | 8.86 (225) | 9.29 (236) | 14.37 (365) | 0.30 (7.5) | 24 (11) | 455 |
| 4034-FVG+ | 9.84 (250) | 14.96 (380) | 8.86 (225) | 9.29 (236) | 14.37 (365) | 0.30 (7.5) | 24 (11) | 570 |
| 4041-FVG+ | 12.80 (325) | 17.72 (450) | 11.22 (285) | 10.83 (275) | 17.13 (435) | 0.30 (7.5) | 60 (27) | 660 |
| 4052-FVG+ | 12.80 (325) | 17.72 (450) | 11.22 (285) | 10.83 (275) | 17.13 (435) | 0.30 (7.5) | 60 (27) | 880 |
| 4065-FVG+ | 12.80 (325) | 24.61 (625) | 11.22 (285) | 10.83 (275) | 24.02 (610) | 0.30 (7.5) | 97 (44) | 1020 |
| 4080-FVG+ | 12.80 (325) | 24.61 (625) | 11.22 (285) | 10.83 (275) | 24.02 (610) | 0.30 (7.5) | 97 (44) | 1245 |
| 4096-FVG+ | 12.80 (325) | 24.61 (625) | 11.22 (285) | 10.83 (275) | 24.02 (610) | 0.30 (7.5) | 97 (44) | 1385 |
| 4128-FVG+ | 17.91 (455) | 32.28 (820) | 13.78 (350) | 13.78 (350) | 31.30 (795) | 0.49 (12.5) | 174 (79) | 1820 |
| 4165-FVG+ | 17.91 (455) | 32.28 (820) | 13.78 (350) | 13.78 (350) | 31.30 (795) | 0.49 (12.5) | 176 (80) | 2320 |
| 4224-FVG+ | 22.64 (575) | 36.42 (925) | 14.76 (375) | 17.52 (445) | 35.24 (895) | 0.59 (15) | 298 (135) | 3030 |
| 4302-FVG+ | 22.64 (575) | 36.42 (925) | 15.75 (400) | 17.52 (445) | 35.24 (895) | 0.59 (15) | 320 (145) | 4190 |
| 4450-FVG+ | 37.40 (950) | 57.09 (1450) | 17.13 (435) | 29.53 (750) | 55.12 (1400) | 0.98 (25) | 794 (360) | 6850 |
| 4605-FVG+ | 37.80 (960) | 62.99 (1600) | 17.91 (455) | 29.53 (750) | 61.02 (1550) | 0.98 (25) | 926 (420) | 9730 |

575V Class

| Model | Overall Dimensions—in. & (mm) | | | Mounting Dimensions—in. & (mm) | | | Wt Lbs/(kg) | Heat Loss (W) |
|-----------|-------------------------------|-------------------|----------------|--------------------------------|-----------------|----------------|--------------|---------------|
| | W | H | D | W1 | H1 | H2 | | Total |
| 5003-FVG+ | 5.51 (140) | 11.02 (280) | 7.09 (180) | 4.96 (126) | 10.47 (266) | 0.28 (7) | 8.8 (4) | 90 |
| 5004-FVG+ | 5.51 (140) | 11.02 (280) | 7.09 (180) | 4.96 (126) | 10.47 (266) | 0.28 (7) | 8.8 (4) | 105 |
| 5006-FVG+ | 7.87 (200) | 11.81 (300) | 8.07 (205) | 7.32 (186) | 11.22 (285) | 0.31 (8) | 13 (6) | 140 |
| 5009-FVG+ | 7.87 (200) | 11.81 (300) | 8.07 (205) | 7.32 (186) | 11.22 (285) | 0.31 (8) | 14 (6.5) | 205 |
| 5012-FVG+ | 7.87 (200) | 11.81 (300) | 8.07 (205) | 7.32 (186) | 11.22 (285) | 0.31 (8) | 14 (6.5) | 220 |
| 5017-FVG+ | 9.84 (250) | 14.96 (380) | 8.86 (225) | 9.29 (236) | 14.37 (365) | 0.29 (7.5) | 28 (13) | 330 |
| 5022-FVG+ | 9.84 (250) | 14.96 (380) | 8.86 (225) | 9.29 (236) | 14.37 (365) | 0.29 (7.5) | 28 (13) | 460 |
| 5027-FVG+ | 15.75 (400) | 29.53 (750) | 11.22 (285) | 11.81 (300) | 28.74 (730) | 0.39 (10) | 97 (44) | 540 |
| 5032-FVG+ | 15.75 (400) | 29.53 (750) | 11.22 (285) | 11.81 (300) | 28.74 (730) | 0.39 (10) | 97 (44) | 730 |
| 5041-FVG+ | 22.64 (575) | 33.46 (850) | 11.81 (300) | 18.71 (475) | 32.48 (825) | 0.49 (12.5) | 156 (72) | 820 |
| 5052-FVG+ | 22.64 (575) | 33.46 (850) | 11.81 (300) | 18.71 (475) | 32.48 (825) | 0.49 (12.5) | 156 (72) | 1220 |
| 5062-FVG+ | 22.64 (575) | 33.46 (850) | 11.81 (300) | 18.71 (475) | 32.48 (825) | 0.49 (12.5) | 156 (72) | 1650 |
| 5077-FVG+ | 22.64 (575) | 41.34 (1050) | 12.80 (325) | 18.70 (475) | 40.35 (1025) | 0.49 (12.5) | 195 (90) | 1750 |
| 5099-FVG+ | 22.64 (575) | 41.97 (1066) | 12.80 (325) | 18.70 (475) | 40.35 (1025) | 0.49 (12.5) | 195 (90) | 2250 |
| 5130-FVG+ | 22.80 (579) | 57.68 (1465) | 12.99 (330) | 18.70 (475) | 48.23 (1225) | 0.49 (12.5) | 271 (125) | 2350 |
| 5172-FVG+ | 22.80 (579) | 77.43 (1966.5) | 13.98 (355) | 18.70 (475) | 61.81 (1570) | 0.59 (15) | 331 (153) | 3200 |
| 5200-FVG+ | 22.80 (579) | 77.43 (1966.5) | 13.98 (355) | 18.70 (475) | 61.81 (1570) | 0.59 (15) | 342 (158) | 4700 |

This page intentionally left blank.

c h a p t e r **3**

Wiring

This page intentionally left blank.

IMPULSE•VG+ Series 2 Wiring Practices



WARNING

Before you wire the drive, review the following practices to help ensure that your system is wired properly.

- **Do not** connect the main output terminals (T1, T2, and T3) to the incoming, three-phase AC source. This will damage the unit!
- Except for Terminals 18, 19, and 20, do not connect the control board terminals directly to the 120VAC user input device. This will damage the unit!
- Ensure that the drive-to-motor wiring distance is less than 150 ft unless appropriate reactors and/or filters are used.
- If a device that can interrupt power is installed between the drive and the motor, install a reactor on the output side of the drive.
- On external user input devices, use hard contact inputs rather than solid-state inputs.
- If the power source is 500 kVA or greater, or more than 10 times the inverter kVA rating, ensure that there is at least 3 percent impedance between the power source and the drive input. To accomplish this, you can install a DC reactor between inverter terminals ⊕1 and ⊕2, or use an AC line reactor on the input of the drive. If you don't provide enough impedance, excessive peak currents could damage the input power supply circuit.
- If the user input device is a PLC TRIAC output, use a 5-K Ω , 10-W resistor between the signal and L2 (X2).
- Comply with "Suggested Circuit Protection Specifications" on page 3-6.
- Use time delay fuses, which are sized at 150% of drive's continuous-rated current, for drive input protection.
- Use appropriate R-C or MOV type surge absorbers across the coil of all contactors and relays in the system. Failure to do so could result in noise-related, nuisance fault incidents.
- Use external dynamic braking resistors for all applications.
- Do not ground the drive with any large-current machines.
- Before you use any welding or high-current machines near the crane, disconnect all line and ground wiring.
- Do not use output contactors between the drive and the motor.
- Do not let the wiring leads come in contact with the drive enclosure.
- Do not connect power factor correction capacitors to the drive input or output.
- Hard-wire the drive and motor (e.g., festoon cable). Do not use sliding collector bars.
- If you have a user input device or interface board that is remote, use shielded cable between the drive input terminals and the interface output terminals or user input device(s).
- Before turning on the drive, check the output circuit (T1, T2 and T3) for possible short circuits and ground faults.

- Increase the wire size by one size for every 250 ft. between the drive and motor; suggested for center driven cranes, trolleys and bridges. (Voltage drop is especially significant at low frequencies.)
- When using more than one transformer for the drive's power, properly phase each transformer.
- To reverse the direction of rotation, interchange any two motor leads (T1, T2 or T3). (Changing L1, L2 or L3 will not affect the shaft rotation direction.)
- Use shielded cable for all low-level DC speed reference signals (0 to 10VDC, 4 to 20 mA). Ground the shield only at the drive side.
- Please observe National Electrical Code (NEC) guidelines when wiring electrical devices.

Failure to observe these warnings may result in equipment damage.

IMPULSE•VG+ Series 2 Standard Connection Diagram

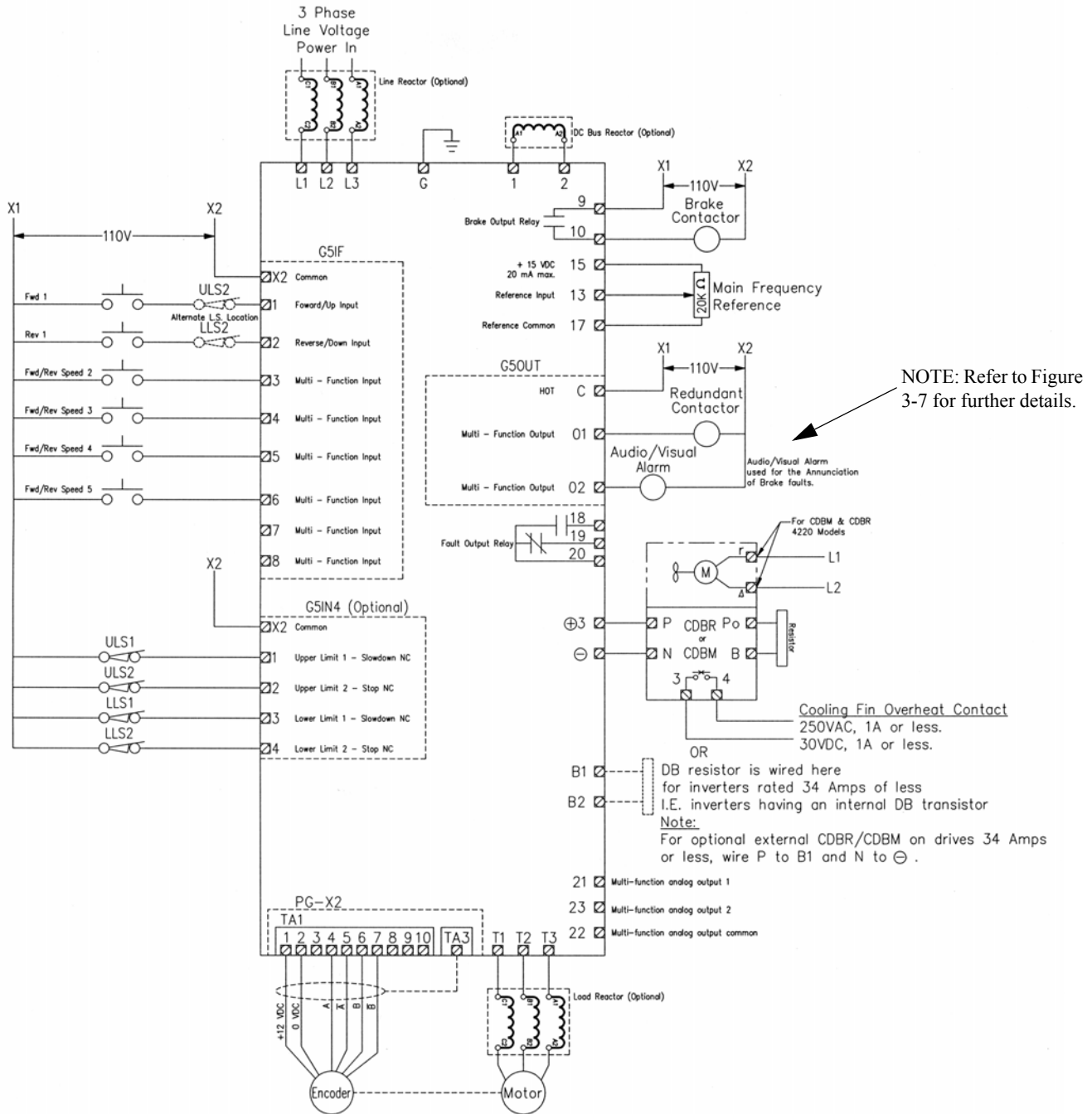

Figure 3-1: IMPULSE•VG+ Series 2 Terminal Diagram

NOTE: Wiring may vary between DBU and CDBR.

Suggested Circuit Protection Specifications and Wire Size

In order to comply with most safety standards, some circuit protective devices should be used between the incoming three-phase power supply and the IMPULSE•VG+ Series 2. These devices can be thermal, magnetic, or molded-case breakers (MCCB); or “slow-blow” type fuses such as “CCMR” or “J.”



CAUTION:

The following guidelines are only suggested values. Always conform to local electrical codes and wiring practices.

| Model # | Rated Current(A) Input Fuse | Inverse Time | | Wiring Size (AWG/KCMIL) | | |
|-------------------|--------------------------------|--------------------------------|--------------------------------|-----------------------------|-------------------|----------------------|
| | | Time Delay Input Fuse Class | Molded/Case Circuit Breaker | Power Circuit Wiring (1) | Control Wiring | Ground Copper (2) |
| 230V Class | | | | | | |
| 2006 -FVG+ | 9 | CC | 10 | 12 | 16/14 | 12 |
| 2008 -FVG+ | 12 | CC | 15 | 12 | 16/14 | 12 |
| 2011 -FVG+ | 17.5 | CC | 25 | 12 | 16/14 | 12 |
| 2017 -FVG+ | 25 | J | 35 | 12 | 16/14 | 10 |
| 2025 -FVG+ | 35 | J | 50 | 12 | 16/14 | 10 |
| 2033 -FVG+ | 45 | J | 60 | 10 | 16/14 | 10 |
| 2054 -FVG+ | 70 | J | 100 | 6 | 16/14 | 8 |
| 2068 -FVG+ | 90 | J | 125 | 4 | 16/14 | 8 |
| 2080 -FVG+ | 100 | J | 150 | 4 | 16/14 | 8 |
| 2130 -FVG+ | 175 | J | 250 | 1/0 | 16/14 | 6 |
| 2160 -FVG+ | 200 | J | 300 | 2/0 | 16/14 | 6 |
| 2224 -FVG+ | 300 | J | 450 | (2)1/0 | 16/14 | 4 |
| 2300 -FVG+ | 400 | J | 600 | (2) 1/0 | 16/14 | 2 |
| 460V Class | | | | | | |
| 4001 -FVG+ | 3 | CC | 10 | 12 | 16/14 | 12 |
| 4003 -FVG+ | 6 | CC | 10 | 12 | 16/14 | 12 |
| 4005 -FVG+ | 8 | CC | 10 | 12 | 16/14 | 12 |
| 4008 -FVG+ | 12 | CC | 15 | 12 | 16/14 | 12 |
| 4011 -FVG+ | 17.5 | CC | 25 | 12 | 16/14 | 12 |
| 4014 -FVG+ | 25 | CC | 30 | 12 | 16/14 | 10 |
| 4021 -FVG+ | 30 | J | 40 | 12 | 16/14 | 10 |
| 4028 -FVG+ | 40 | J | 50 | 10 | 16/14 | 10 |
| 4034 -FVG+ | 45 | J | 70 | 10 | 16/14 | 10 |
| 4041 -FVG+ | 60 | J | 80 | 8 | 16/14 | 10 |
| 4052 -FVG+ | 70 | J | 100 | 6 | 16/14 | 8 |
| 4065 -FVG+ | 90 | J | 125 | 4 | 16/14 | 8 |

| Model # | Rated Current(A) | Inverse Time | | | | |
|-------------------|------------------|-----------------------------|-----------------------------|--|----------------|-------------------|
| | Input Fuse | Time Delay Input Fuse Class | Molded/Case Circuit Breaker | Wiring Size (AWG/KCMIL) Power Circuit Wiring (1) | Control Wiring | Ground Copper (2) |
| 4080 -FVG+ | 100 | J | 150 | 4 | 16/14 | 8 |
| 4096 -FVG+ | 125 | J | 200 | 2 | 16/14 | 6 |
| 4128 -FVG+ | 175 | J | 250 | 1/0 | 16/14 | 6 |
| 4165 -FVG+ | 225 | J | 300 | 2/0 | 16/14 | 4 |
| 4224 -FVG+ | 300 | J | 450 | (2) 1/0 | 16/14 | 4 |
| 4302 -FVG+ | 400 | J | 600 | (2) 1/0 | 16/14 | 2 |
| 4450 -FVG+ | 600 | J | 900 | (2) 4/0 | 16/14 | 1/0 |
| 4605 -FVG+ | 800 | L | 1200 | (2) 300 KCMIL | 16/14 | 1/0 |
| 575V Class | | | | | | |
| 5003-FVG+ | 5 | CC | 10 | 12 | 16/14 | 12 |
| 5004-FVG+ | 7 | CC | 10 | 12 | 16/14 | 12 |
| 5006-FVG+ | 10 | CC | 10 | 12 | 16/14 | 12 |
| 5009-FVG+ | 15 | CC | 20 | 12 | 16/14 | 12 |
| 5012-FVG+ | 20 | CC | 25 | 12 | 16/14 | 12 |
| 5017-FVG+ | 25 | CC | 35 | 12 | 16/14 | 10 |
| 5022-FVG+ | 35 | J | 45 | 12 | 16/14 | 10 |
| 5027-FVG+ | 40 | J | 50 | 10 | 16/14 | 10 |
| 5032-FVG+ | 45 | J | 60 | 10 | 16/14 | 10 |
| 5041-FVG+ | 60 | J | 80 | 8 | 16/14 | 10 |
| 5052-FVG+ | 70 | J | 100 | 6 | 16/14 | 8 |
| 5062-FVG+ | 90 | J | 125 | 4 | 16/14 | 8 |
| 5077-FVG+ | 100 | J | 150 | 4 | 16/14 | 8 |
| 5099-FVG+ | 125 | J | 200 | 2 | 16/14 | 6 |
| 5130-FVG+ | 175 | J | 250 | 1/0 | 16/14 | 6 |
| 5172-FVG+ | 225 | J | 350 | 2/0 | 16/14 | 4 |
| 5200-FVG+ | 300 | J | 450 | 3/0 | 16/14 | 4 |

References:

1. NFPA 70 National Electrical Code 1999. Table 610-14(a) 90° C, 60-minute, copper
2. NFPA 70 National Electrical Code 1999. Table 250-122.

Power Circuit Wiring Procedures

To wire the power circuit for IMPULSE•VG+ Series 2:

1. Run the three-phase power supply wires through an appropriate enclosure hole.
2. Referring to “Suggested Circuit Protection Specifications—IMPULSE•VG+ Series 2” and the following two tables, connect the three-phase power supply wires to a circuit protection system.
3. Connect the three-phase power supply wires from the circuit protection Terminals L1, L2 and L3.
4. From Terminals T1, T2 and T3, connect the power output wires to the motor. If a load reactor is used, connect these output wires to the reactor input; then connect the reactor output to the motor.

NOTE: If a device that can interrupt power is installed between the drive and the motor, install a reactor on the output side of the drive.

5. For Models 4041-FVG+ and greater, ensure the jumper plug is inserted in the printed-circuit board (3PCB), which is underneath the control board, as follows:

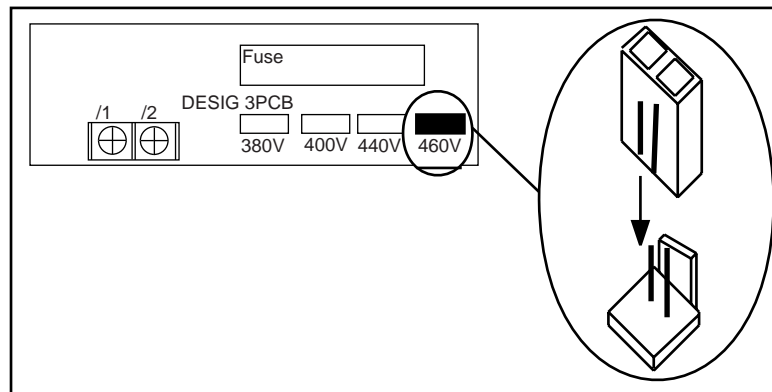

Figure 3-2: Models 4041-FVG+ to 4096-FVG+

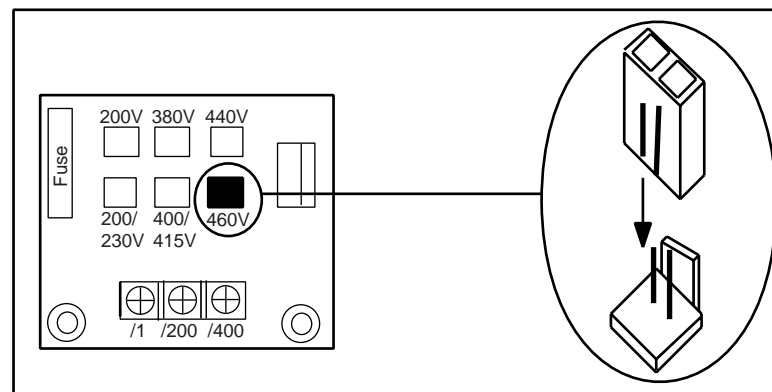



Figure 3-3: Models 4128-FVG+ to 4605-FVG+

230 V Class Terminal Functions

| | Model | 2006-FVG+ to 2033-FVG+ | 2054-FVG+ to 2068-FVG+ | 2080-FVG+ | 2130-FVG+ to 2300-FVG+ |
|---|--|--|---|---|------------------------|
| | <i>Rated Current</i> | 6 to 33 Amps | 54 to 68 Amps | 80 Amps | 130 to 300 Amps |
| Terminal | L1 | Main circuit input power supply | | | |
| | L2 | | | | |
| | L3 | | | | |
| | T1 | Inverter output | | | |
| | T2 | | | | |
| | T3 | | | | |
| | B1 | Braking resistor | n/a | | |
| | B2 | | | | |
| | θ | DC reactor (⊕1-⊕2) DC Power supply (⊕1-θ) | DC reactor (⊕1-⊕2) DC power supply (⊕1-⊕) Braking unit (⊕3-θ) | DC power supply (⊕1-θ) Braking unit (⊕3-θ) (⊕1 and ⊕2 terminals not provided) | |
| | ⊕1 | | | | |
| | ⊕2 | | | | |
| | ⊕3 | | | | |
| | r (l 1) | n/a | | Cooling fan power supply | |
| | s (l 2) | | | | |
|  | Ground terminal (Ground resistance: 100 Ω or less) | | | | |

460 V Class Terminal Functions

| | Model | 4003-FVG+ to 4034-FVG+ | 4041-FVG+ to 4096-FVG+ | 4128-FVG+ to 4302-FVG+ | 4450-FVG+ to 4605-FVG+ | |
|---|---|--|---|--|------------------------|--|
| | <i>Rated Current</i> | 3.6 to 34 Amps | 41 to 96 Amps | 128 to 302 Amps | 450 to 605 Amps | |
| Terminal | L1 | Main circuit input power supply | | | | |
| | L2 | | | | | |
| | L3 | | | | | |
| | T1 | Inverter output | | | | |
| | T2 | | | | | |
| | T3 | | | | | |
| | B1 | Braking resistor | n/a | | | |
| | B2 | | | | | |
| | θ | DC reactor (⊕1-⊕2) DC power supply (⊕1-θ) | DC reactor (⊕1-⊕2) DC power supply (⊕1-θ) Braking unit (⊕3-θ) | Braking unit (⊕3-θ) (⊕1 and ⊕2 terminals not provided) | | |
| | ⊕1 | | | | | |
| | ⊕2 | | | | | |
| | ⊕3 | | | | | |
| | s (l 1) | n/a | | Cooling fan power supply | n/a | |
| | r (l 2) | | | | | |
| s200 | n/a | | n/a | Cooling fan power supply (Control power supply) r-s200: 200 to 230VAC input r-s400: 380 to 460VAC input | | |
| s400 | | | | | | |
|  | Ground terminal (Ground resistance: 10 Ω or less) | | | | | |

575V Class Terminal Functions

| | <i>Model</i> | 5003-FVG+ to 5032-FVG+ | 5003-FVG+ to 5017-FVG+ | 5041-FVG+ to 5200-FVG+ |
|-----------------|---|---|---|--------------------------|
| | <i>Rated Current</i> | 3 to 32 Amps | 3 to 17 Amps | 41 to 200 Amps |
| Terminal | L1 (R) | Main circuit input power supply | | |
| | L2 (S) | | | |
| | L3 (T) | | | |
| | T1 (u) | Inverter output | | |
| | T2 (V) | | | |
| | T3 (W) | | | |
| | B1 | Braking resistor | | n/a |
| | B2 | | | |
| | θ | DC reactor (⊕1-⊕2) DC power supply (⊕-θ) Braking Unit(⊕1-θ) | DC power supply (⊕1-θ) Braking unit (⊕1-θ) (⊕2 terminal not provided) | |
| | ⊕1 | | | |
| | ⊕2 | | | |
| | I1 (r) | n/a | | Cooling fan power supply |
| | I2 (s) | | | |
| |  | Ground terminal (Ground resistance: 10 Ω or less) | | |

Grounding

6. Connect terminal G to the common panel ground. Use ground wiring as specified in “Suggested Circuit Protection and Wire Size” on page 3-6, and keep the length as short as possible.
 - Ground Resistance: 230V class; 100 Ω or less, 460V or greater class; 10 Ω or less.
 - Never run the IMPULSE•VG+ Series 2 drive ground wires in common with welding machines, or other high-current electrical equipment.
 - When more than one drive is used for the same system, ground each directly or daisy-chain to the ground pole. Do not loop the ground wires.

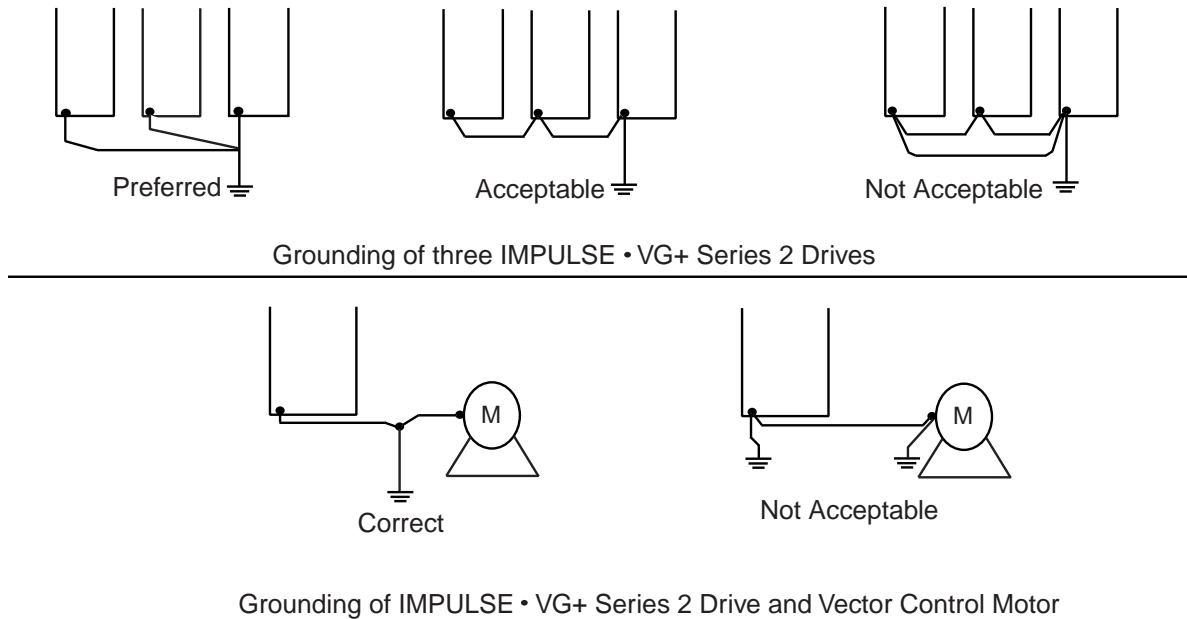

Figure 3-4: Grounding

Wiring the Control Circuit

Control Input

IMPULSE•VG+ Series 2 is designed to interface directly with a 120VAC user input device. User input devices include: pendant controls (pushbutton station), remote control transmitters (infrared and radio), master switches, programmable logic controls (PLC), and personal computers. This design feature eliminates the need for interface relays or isolation circuitry. The user interface device is connected to the G5IF 120V Control Interface Card, which includes Terminals 1, 2, 3, 4, 5, 6, 7, and 8. Four more terminals can be added with the optional G5IN4 120V Control Input Card.

NOTE: Terminal X2 is also on both control input cards, and should always be connected to X2 of the user input device.

For the G5IF, Terminals 1 and 2 are always used for the directional run commands (FORWARD, REVERSE, UP, DOWN, LEFT, RIGHT). The other terminals are multi-function terminals, and are used for speed control and other characteristics. With multi-function terminals you can assign entirely different functions and performance characteristics without having to rewire the drive.

Additional Input Terminals

Four additional digital input terminals can be added with the optional G5IN4 120V input card. To program the G5IN4 input card, please refer to Chapter 5; “Special Function Group, G5IN4 Digital Multi-Function Inputs” Sections (C9-XX) on page 5-45.

Control Output

The table below summarizes the control output terminal functions:

| Circuit Board | Terminal | Function |
|---------------------|----------|--|
| G5OUT | C | Connection to X1 of 120VAC power supply |
| G5OUT | 01 | Multi-function Output (See H2 constants) |
| G5OUT | 02 | Multi-function Output (See H2 constants) |
| Drive Control Board | 9 | Electric brake output; electric brake release signal |
| Drive Control Board | 10 | Electric brake output; electric brake release signal |
| Drive Control Board | 18 | Fault output—normally open; closed to COM at fault |
| Drive Control Board | 19 | Fault output—normally closed; open to COM at fault |
| Drive Control Board | 20 | Fault output—common |

Control Circuit Terminals

The table below outlines the functions of the control circuit terminals.

| Classification | Terminal | Signal Function | Description | | Signal Level |
|------------------------|--|--|--|--|---|
| Sequence Input Signal | 1 | Forward run/stop | Forward run when closed, stop when open | | Photo-coupler isolation Input: +24VDC 8mA |
| | 2 | Reverse run/stop | Reverse run when closed, stop when open | | |
| | 3 | Speed 2 | Multi-function contact inputs (H1-01 to H1-06) | | |
| | 4 | Speed 3 | | | |
| | 5 | Speed 4 | | | |
| | 6 | Speed 5 | | | |
| | 7 | External Fault | | | |
| | 8 | M-Speed Gain 1 | | | |
| 11 | Sequence control input common terminal | - | | | |
| Analog Input Signal | 15 | +15V Power supply output | For analog command +15V power supply | | +15V (Allowable current 20 mA max.) |
| | 33 | -15V Power supply output | For analog command -15V power supply | | -15V (Allowable current 20 mA max.) |
| | 13 | Master frequency reference | -10 to +10V/-100% to 100% 0 to +10V/0 to 100% | | -10 to +10V (20kΩ), 0 to +10V/(20kΩ) |
| | 14 | Multi-function analog reference | 4 to 20 mA/0 to 100% -10 to +10V/-100% to 100% 0 to 10 V/0 to 100% | Multi-function analog reference (H3-05) | 4 to 20mA (250Ω) -10 to +10V (20kΩ), 0 to +10V/(20kΩ) |
| | 16 | Multi-function analog input | -10 to +10V/-100% to +100% 0 to +10 V/0 to 100% | Auxiliary analog input (H3-05) | -10 to +10V (20kΩ), 0 to +10V/(20kΩ) |
| | 17 | Common terminal for control circuit | 0V | | - |
| | 12 | Connection to shield sheath of signal lead | - | | - |
| Sequence Output Signal | 9 | Brake output | Multi-function output (H2-01 to H2-03) | | Dry contact Contact capacity: 250VAC, 1A or less 30VDC, 1A or less |
| | 10 | | | | |
| | 25 | Brake output | | | Open collector output 48V, 50mA or less |
| | 26 | Fault annunciate | | | |
| | 27 | Open collector output common | | | - |
| | 18 | Fault contact output (NO/NC contact) | Terminals 18 & 20 N/O; closed at major faults Terminals 19 & 20 N/C open at major fault | | Dry contact Contact capacity: 250VAC 1A or less 30VDC 1A or less |
| | 19 | | | | |
| 20 | | | | | |
| Analog Output Signal | 21 | Multi-Function Analog Output 1 | 0 to ± 10V | Multi-function analog monitor (H4-01 to H4-03) | 0 to ±10V Max. ±5% 2mA or less |
| | 22 | Common | | | |
| | 23 | Multi-Function Analog Output 2 | 0 to ± 10V | Multi-function analog monitor 2 (H4-04 to H4-06) | 0 to ±10V Max. ±5% 2mA or less |

Control Circuit Wiring Procedures

To wire the drive control circuit for IMPULSE•VG+ Series 2:

1. While the G5IF 120V Control Voltage Interface and G5OUT Control Output Cards are already attached to the drive control terminals when the drive is shipped, the figure below is provided in case you have to reattach these boards.

Figure 3-5: Interface Cards

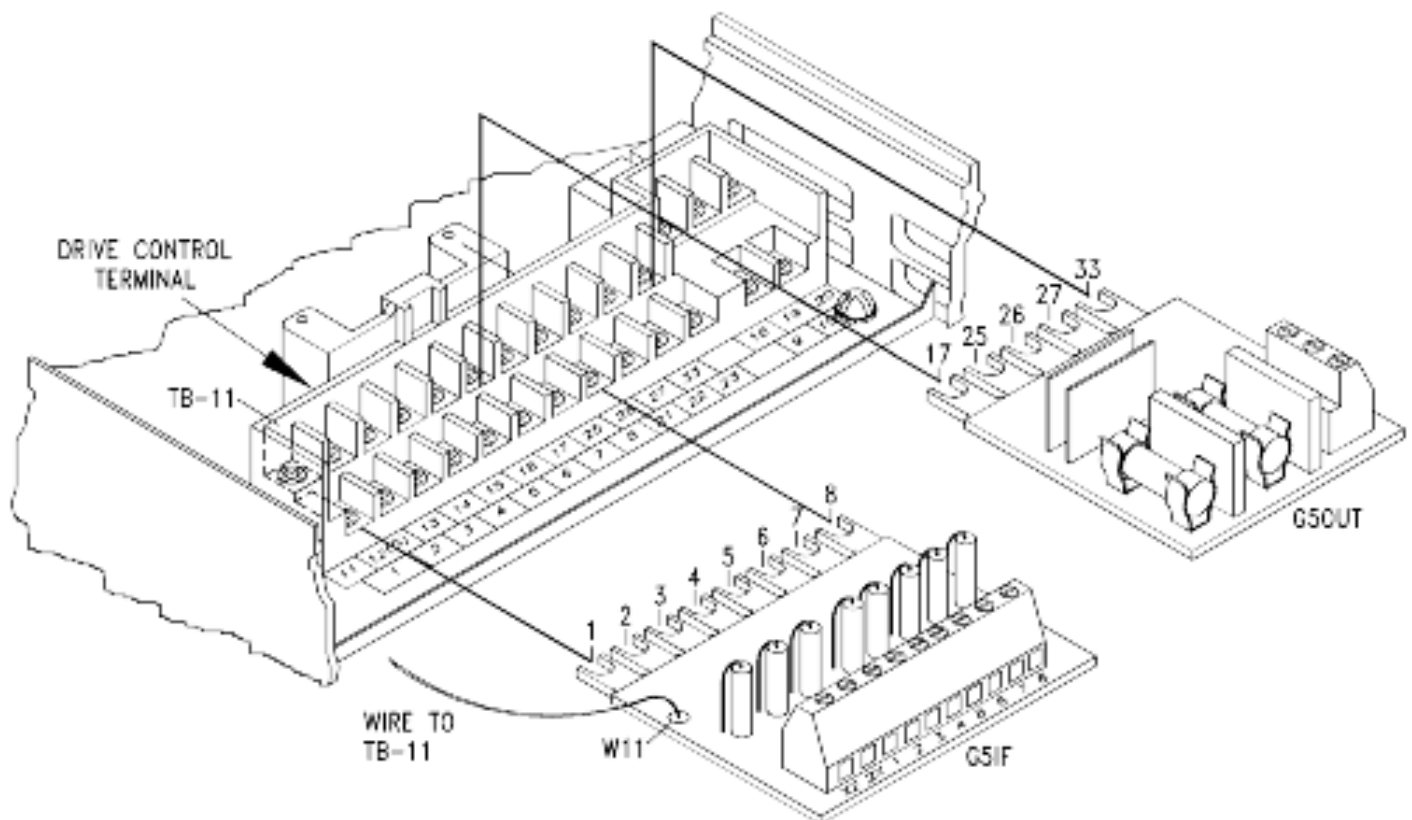

- Connect input terminals—X2, 1, 2, 3, 4, 5, 6 and 7 for G5IF and X2, 1, 2, 3 and 4 for G5IN4—to the user input device. The following drawing shows a typical five-speed interconnection and should help you understand how to wire any control circuit application. For more information on multi-function inputs, see **Terminal 3 Sel (H1-01)** through **Terminal 8 Sel (H1-06)** in Chapter 5 on page 5-82, Terminal Parameters Group, Digital Inputs Section.

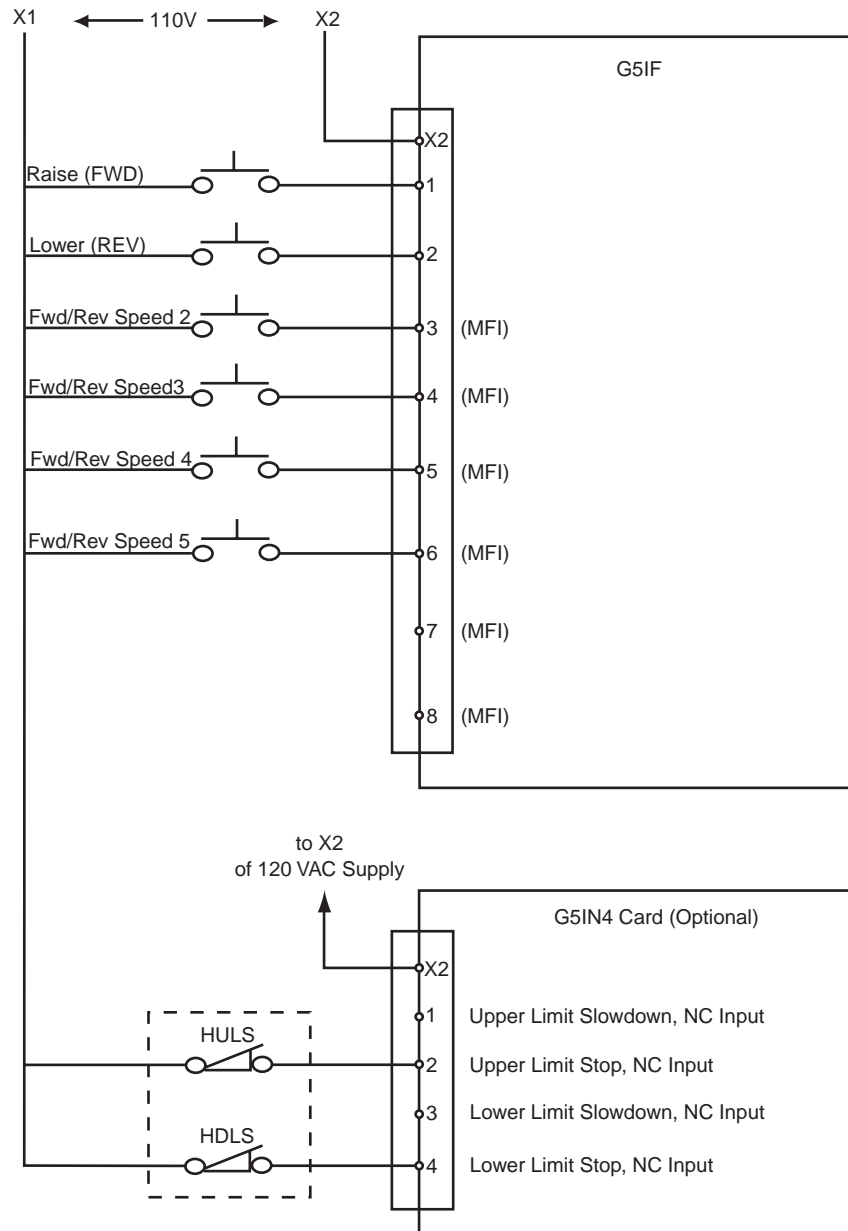

Figure 3-6: Five-Step Multi-Speed Terminal Diagram (Example)

- Install G5OUT card to the drive as indicated in Figure 3-5 “Interface Cards” on page 3-14.
- Connect the output terminals, as indicated in the following drawing, to the intended output device(s).

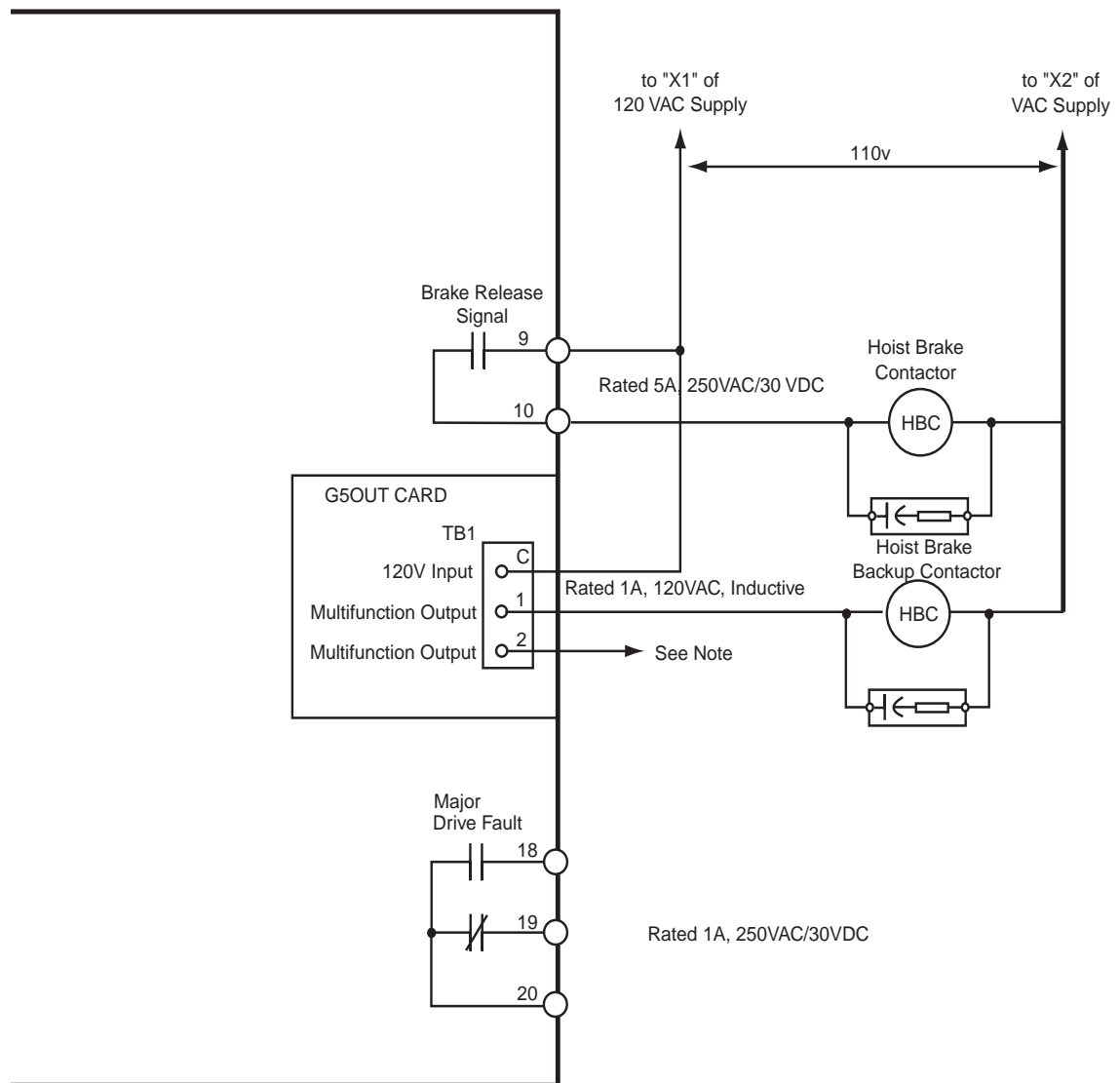

Figure 3-7: Output Terminals

5. Connect the G5IF common lead (blue wire W11) to Terminal 11 on the drive control terminal. Refer to Figure 3-5 “Interface Cards” on page 3-14.

NOTE: *If the drive is being applied in a no-load brake hoist application, Electromotive Systems recommends the use of an external warning device wired to terminal 2 of the G5OUT card to annunciate a brake failure alarm. Reference No-Load Brake Start/ Stop and Digital Outputs – Fault Annunciate in Chapter 5 on page 5-32 for more details.*

Surge Absorber Selection

6. Install appropriate R-C or MOV type surge absorbers across the coils of any contactors installed in the drive's control panel enclosure.

Electric Brake Coil and Reattachment

7. Connect 110VAC supply (X1) to Terminal 9, the electric brake contactor coil to Terminal 10, and the other side of the contactor coil to the 110V return (X2).
8. Reattach the G5IF card to the lower-level control board Terminals 1 through 8. (Refer to Figure 3-5 "Interface Cards" on page 3-14.)
9. Reattach the G5OUT card to top-level control board Terminals 17, 25, 26, 27, and 33. (Refer to Figure 3-5 "Interface Cards" on page 3-14.)

Cover and Keypad

NOTE: Before you perform the following step, wire the encoder circuit, which is explained in "Wiring the Encoder Circuit" in the following section.

10. Refasten the cover, inserting the top of the cover first.

11. Referring to the following drawing, reinsert the keypad in the keypad well of the cover by aligning the keypad with the claws and locking the keypad into place.

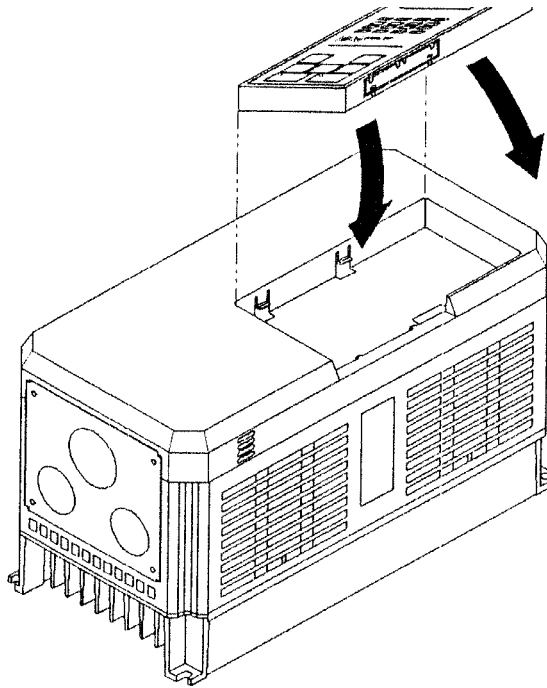

Figure 3-8: Cover and Keypad

Wiring the Encoder Circuit

A shaft-mounted encoder is required to provide speed and shaft position feedback to IMPULSE•VG+ Series 2. Without an encoder, a flux vector control cannot operate properly.

Before you wire the encoder circuit, refer to the specification tables in this section and to “Wiring Specifications.”

Encoder Circuit Wiring Procedures

Encoder Specifications

| | |
|------------------------|--|
| Power supply | +12VDC; if current demand is greater than 200 mA, an auxiliary power supply must be provided |
| Output Type | Quadrature (A and B channels; Z is not necessary) |
| Type of output circuit | High-speed, differential line drive |
| Resolution | 1024 PPR |
| Mounting method | Encoder must be direct-coupled to motor shaft, using a zero-backlash-type coupling. |

To wire the encoder circuit for IMPULSE•VG+ Series 2 (assuming the cover and keypad are detached):

1. Direct-couple the encoder to the motor shaft, using a zero-backlash-type coupling.
NOTE: Do not connect the encoder to the motor with roller chain or gear drive. If unable to direct-couple the encoder, use a timing belt to drive the encoder. (Contact Electromotive Systems for encoder kits.) Also, do not connect the encoder to the low-speed shaft of a speed reducer.
2. Connect the encoder to the PG-X2 Encoder Interface Card. Refer to Figure 3-9: “Generic Encoder” and Figure 3-10: “PG-X2 Interface Card Terminal Functions” on page 3-20.
NOTE: Use twisted-pair, shielded cable (Electromotive R-20/6, Belden 9730, or Brand Rex T-11651). Strip the encoder wires .25 in. (5.5 mm). Keep the wiring length less than 300 feet. (For cable lengths greater than 300 feet, contact Electromotive Systems for information on available fiber optic cable systems.)
3. Ground the shielded cable to Terminal TA-3 of the PG-X2 Encoder Interface Card. (Ground only one end of the shielded cable.)
NOTE: For LakeShore encoders, the shield connection is not considered “Ground.” The shield should be grounded at TA-3 and connected to the shield at the encoder.
4. Whenever possible, the encoder cable should be wired in a continuous run between the motor and drive. If it cannot be a direct run, the splice should be in its own junction box and isolated from the power wires.

Encoder Wiring Diagrams and Information

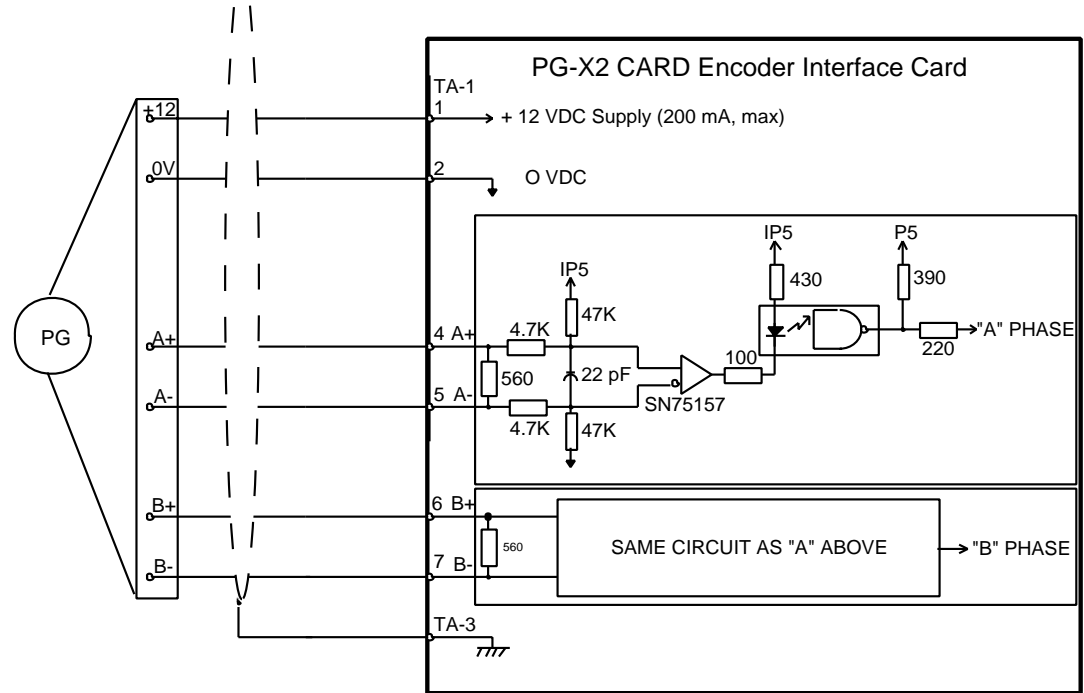

Figure 3-9: Generic Encoder

The following drawing and table shows you how to connect a LakeShore Model 8500 encoder to the PG-X2 Encoder Interface Card.

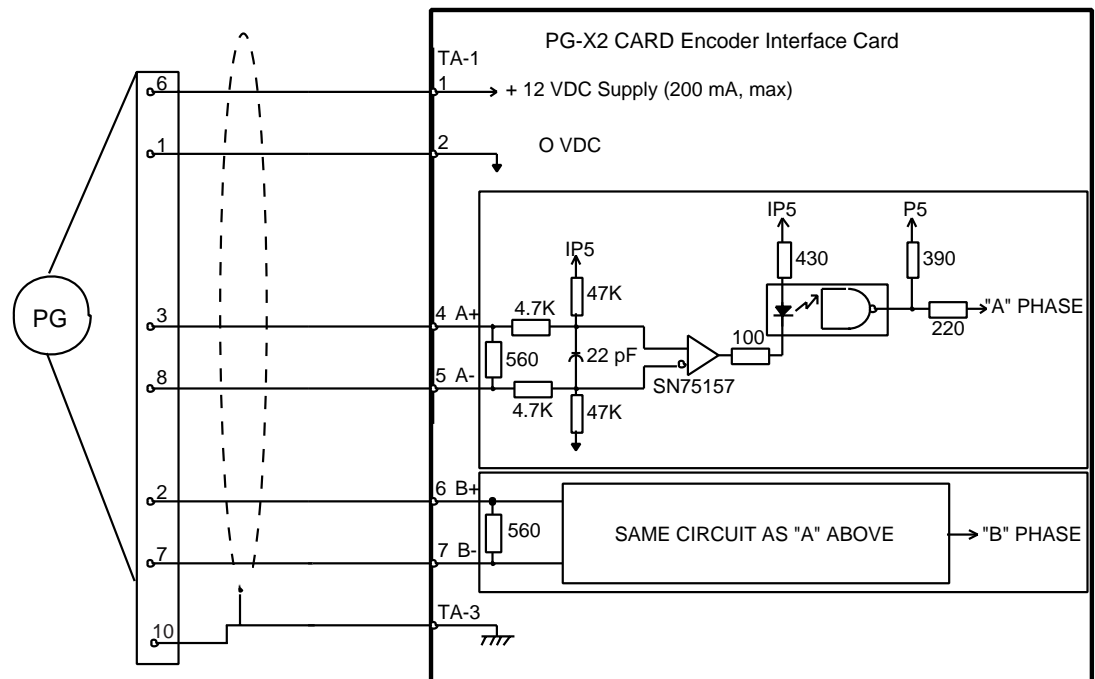

Figure 3-10: LakeShore Model 8500 Encoder

Heartsore Model SL56 Encoder Wiring Scheme

| Encoder Signal | Wire Color | PG-X2 Terminal (TA-1) |
|-----------------------|-------------------|------------------------------|
| +5 to 15VDC | Red | 1 |
| OV | Black | 2 |
| A+ | Blue | 4 |
| A- | Gray | 5 |
| B+ | Green | 6 |
| B- | Yellow | 7 |
| Shield | N/A | TA3 |

PG-X2 Encoder Interface Card Specifications

| | |
|---|--------------------------------|
| Power supply to encoder: | Dual; +12VDC; 200 mA maximum |
| Encoder input signal: | RS-422–level, line-driver-type |
| Pulse monitor output signal (repeater): | RS-422–level, line-driver-type |
| Pulse phases accepted: | Phases A and B (both + and -) |
| Maximum input frequency: | 300 kHz |
| Connector type: | Phoenix MKDS1 series |

PG-X2 Encoder Interface Card Terminal Functions

| Terminal Block | Pin # | Function |
|-----------------------|--------------|---|
| TA1 | 1 | +12VDC power supply; do not use Pins 1 and 3 together |
| TA1 | 2 | Power supply common |
| TA1 | 3 | Alternate 5VDC power supply for encoder; do not use Pins 1 and 3 together |
| TA1 | 4 | A+ pulse input |
| TA1 | 5 | A- pulse input |
| TA1 | 6 | B+ pulse input |
| TA1 | 7 | B- pulse input |
| TA1 | 10 | Ground |
| TA2 | 1 | A-pulse output |
| TA2 | 2 | A-pulse output |
| TA2 | 3 | B-pulse output |
| TA2 | 4 | B-pulse output |
| TA2 | 7 | Common signal ground terminal |
| TA3 | – | Shielded-sheath connection terminal |

This page intentionally left blank.

c h a p t e r **4**

Programming Basic Features

This page intentionally left blank.

Overview

With its easy-to-use keypad and X-Press Programming, IMPULSE•VG+ Series 2 makes it easy to get up and running right away. In addition to explaining the keypad and X-Press Programming, this chapter explains how to view the scroll settings, get into the programming mode, and program speeds.

Checks Before Powering

After mounting and interconnections are completed, verify:

- Correct connections.
- Correct input power supply. (No voltage drop or imbalance, source kVA \leq 500, unless a line reactor is used.)



WARNING

DO not power 230V-rated drives with 460V power.

- No short circuit conditions.
- No loose screw terminals. (Check especially for loose wire clippings.)
- Proper load conditions.

Precautions

- Only start the motor if motor shaft rotation is stopped.
- Even with small loading, never use a motor whose nameplate amperage exceeds the inverter rated current.



DANGER

Braking method selection as shipped from Electromotive Systems is set for Decelerate to Stop command. Extreme caution should be used. If deceleration time is too long, equipment could run into endoscope device, causing damage to equipment or injury to personnel.

Using the Keypad

With two 16-character lines available, the English keypad display makes it possible to view fault codes and change parameter settings. Parameter settings, with their parameter codes, are displayed in most cases. In addition, the parameter description is included on the top line of the display. The keypad enables you to:

- Program the various drive parameters.
- Monitor the functions of the drive.
- Read alpha-numeric fault-diagnostic indications.
- Operate the drive using the keypad (local operation).



WARNING

Because of the additional potential hazards that are introduced when any drive is operated locally, we advise you to avoid operating it this way. If you do operate the drive locally, be aware that the crane or hoist will move when you press the RUN button. If you have questions, contact Electromotive Systems.

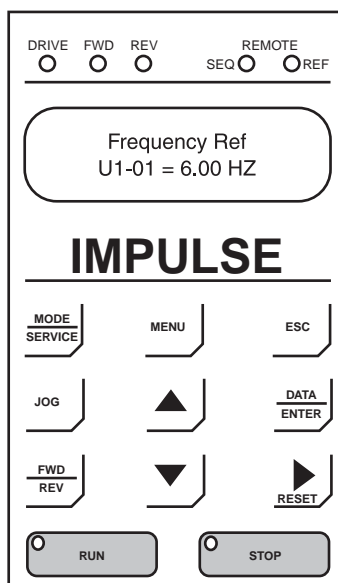

Keypad LED and Button Functions

Some of the keypad buttons, whose functions are described below, are dual-purpose. The dual-purpose keys have one function when used in a view-only mode, and another function when used in a programming mode.



This LED lights only when the drive is in the **Operation** mode, which includes when the drive is first powered up.



This LED lights when the FORWARD command is given.



This LED lights when the REVERSE command is given.



- The SEQ LED lights when selecting the RUN command from the control circuit terminals or serial communication.
- The REF LED lights when the **Speed Reference** is input through control circuit terminals or serial communication.



- Pressing this key toggles between the mode set-up display and the phone number for Electromotive Systems Service Department.
- Also toggles between REMOTE and LOCAL (Digital operator from keypad) operation when 02-1 is set to 1.



Displays to the Main Menu for mode selection.



Backs up to the previous display (before the DATA/ENTER key is depressed).



Jog run is enabled when local operation is selected.



Selects the next mode, parameter group, parameter function, parameter or parameter setting. It also increases the blinking digit of a parameter setting.



Selects the previous mode, parameter group, parameter function, parameter or parameter setting. It also decreases the blinking digit of a parameter setting.



Selects the digit—from left to right—to be changed (indicated by blinking). It also resets the operation at faults.



Selects mode, group, function or parameter. Displays each parameter's set value. By pressing this key again, the set value is entered.



Selects forward or reverse run when LOCAL operation is selected.



- Pressing this key initiates run command when LOCAL operation is selected.
- The red LED lights steadily.



- Pressing this key initiates Base Block stop command.
- The red LED lights steadily when drive is at stop; blinks when Run command is active but output frequency reference is zero, off when drive output is controlling motor speed.

Parameters

There are hundreds of parameters that determine how the drive functions. These parameters are programmed in the drive's software as measurable values or options—both of which will be referred to in this manual as *settings*. While some of these parameters are associated with one setting, others are tied to a number of possible settings.

NOTE: The terms “constant” and “parameter” have the same meaning.

Before shipping the drive to you, we programmed initial settings in the drive's software so that most, if not all, of your crane system requirements are supported. However, if you do find it necessary to change the initial settings, we recommend that you only allow qualified crane system technicians to program the drive. This can be accomplished by using the **Password Barrier** and **Access Level** features. For more information on these security features, see Initialization Set-up on page 4-9.

You also have the option of allowing personnel with limited crane system knowledge to program only certain parameters—**User Parameters**—that you select. To select these parameters, see “User Parameters (A2-XX)” on page 4-15.

Two other features to be aware of are **Initialize Parameters** (A1-05) and **User Defaults** (O2-03). Both these features are related and allow you to revert back to parameter settings that you save. This is especially helpful when you have made a number of programming changes, but want to get back to the settings you had before you made any changes. To program these features, see “Initialize Parameters (A1-05)” and “User Defaults (02-03)” on page 4-15.

IMPULSE•VG+ Series 2 Structure of Parameters

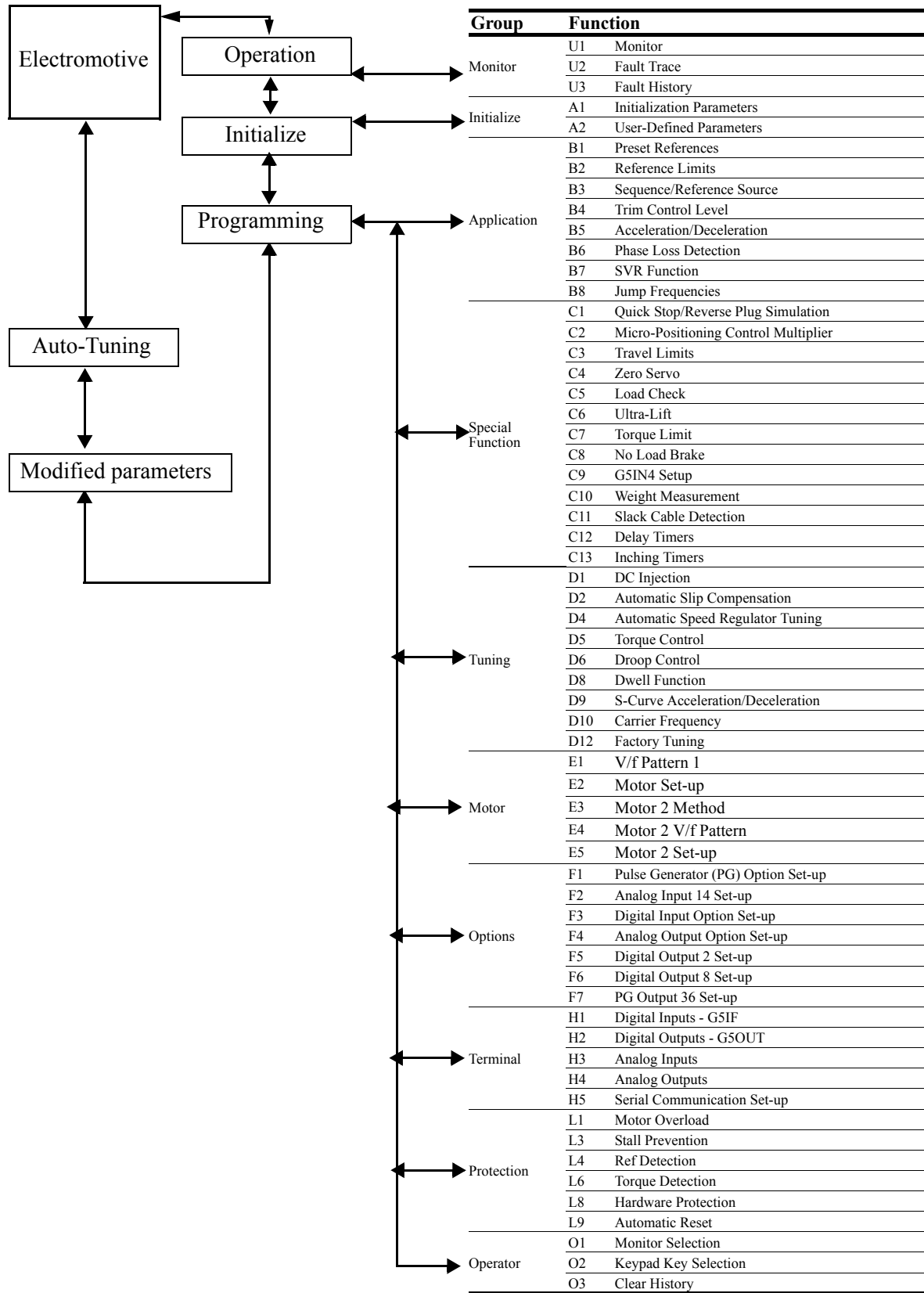

Parameter Modes

All parameters are organized under five modes:

Operation Mode

Drive operation is enabled. Drive status LED lights.

Initialize Mode

Parameter access levels, control method, motion, speed control mode, and passwords are selected.

Programming Mode

Parameters are set/read. Items to be set/read vary depending on the access level setting.

Auto-Tuning Mode

Motor parameters are automatically set by entering tuning data (motor nameplate values) when using open loop vector control method.

Modified Constants Mode

Only parameters that have been changed from the factory settings are set/read.

Initialization Set-up

Parameter Access Level (A1-01)

This parameter allows the “masking” of parameters according to user level. See the following table:

| Setting | Description |
|---------|--|
| 0 | Operation Only |
| 1 | User Program - Accesses parameters selected by OEM (A2-01 to A2-32). |
| 2 | Advanced Level - For advanced programming in special applications. |

Refer to the parameter code table in Chapter 5 for available parameters at each level.

Control Method Selection (A1-02)

Select the control method best suited for your application.

| Setting | Description |
|---------|-------------|
| 3 | Flux Vector |

NOTE: An auto-tune must be performed for all flux vector applications. Refer to the Auto-Tuning section on page 4-16.

Select Motion (A1-03)

Set this parameter to match the motion of application. See tables 4.1 through 4.12 (X-Press Programming) for details.

| Setting | Description |
|---------|--|
| 0 | Traverse - Decelerate to stop upon removal of RUN command. |
| 2 | No-Load Brake Hoist |

Speed Reference (A1-04)

This parameter will automatically define the input terminals for the selections listed below. See tables 4.1 through 4.12 (X-Press Programming) for details.

| Setting | Description |
|---------|---|
| 0 | 5-SPD Multi-step — Defines Terminals 3-6 as speeds 2-5. |
| 1 | 2-Step infinitely variable — Terminals 1 and 2 = b1-01 (Reference 1) and speed hold. Terminal 3 = Accelerate. |
| 2 | 3-Step infinitely variable — Terminals 1 and 2 = b1-01 (Reference 1). Terminal 3 = Speed Hold. Terminal 4 = Accelerate. |
| 3 | Uni-polar analog — Terminals 1 and 2 = A directional input. Terminal 13 = 0-10V. Terminal 14 = 4-20mA. |
| 4 | Bi-polar analog — Terminal 13 = -10 to +10V. An input on Terminal 1 is required, but direction is determined by the reference given on Terminal 13. |
| 5 | 2-SPD Multi-step — Defines Terminal 3 = 2nd speed. |
| 6 | 3-SPD multi-step — Defines Terminals 3 and 4 as speeds 2 and 3 respectively. |
| 7 | Not Used—Defines Terminals 3-8 as not used. Use this setting if using the G5IN4 option card for inputting speed references. |

Parameters Changed by X-Press Programming (Software Versions 14908-14911)

Table 4-1: A1-03=Traverse

| | Parameter | Description | B1-01 | B1-02 | B1-03 | B1-04 | B1-05 | B1-06* | B1-07* | B1-08* | B1-09 | B1-10 |
|-------|-----------|----------------------------|---------|---------|---------|---------|---------|---------|---------|---------|---------------|--------------------|
| | | | Speed 1 | Speed 2 | Speed 3 | Speed 4 | Speed 5 | Speed 6 | Speed 7 | Speed 8 | Jog Reference | Reference Priority |
| A1-04 | A1-04 | 5-Speed Multi-Step | 6.00 | 15.00 | 30.00 | 45.00 | 60.00 | 9999 | 9999 | 9999 | 6.00 | 0 |
| | A1-04 | 2-Step Infinitely Variable | 6.00 | 9999 | 9999 | 9999 | 60.00 | 9999 | 9999 | 9999 | 6.00 | 0 |
| | A1-04 | 3-Step Infinitely Variable | 6.00 | 9999 | 9999 | 9999 | 60.00 | 9999 | 9999 | 9999 | 6.00 | 0 |
| | A1-04 | Uni-Polar Analog | 9999 | 9999 | 9999 | 9999 | 9999 | 9999 | 9999 | 9999 | 6.00 | 1 |
| | A1-04 | Bi-Polar Analog | 9999 | 9999 | 9999 | 9999 | 9999 | 9999 | 9999 | 9999 | 6.00 | 1 |
| | A1-04 | 2-Speed Multi-Step | 20.00 | 60.00 | 9999 | 9999 | 9999 | 9999 | 9999 | 9999 | 6.00 | 0 |
| | A1-04 | 3-Speed Multi-Step | 15.00 | 30.00 | 60.00 | 9999 | 9999 | 9999 | 9999 | 9999 | 6.00 | 0 |
| | A1-04 | Not Used | 15.00 | 30.00 | 60.00 | 9999 | 9999 | 9999 | 9999 | 9999 | 6.00 | 0 |

*Applies only for software versions 14910 and 14911.

Note: Data 9999 denotes no change from previously programmed value.

Table 4-2: A1-03=Traverse (Continued)

| | Parameter | Description | B2-01 | B2-02 | B3-03 | B5-01* | B5-02* | C1-01* | C3-07 | D9-01* | D9-02* | D9-03* | E1-02 | E1-03 |
|-------|-----------|----------------------------|------------------|------------------|-----------------|--------------|--------------|----------------|------------------|------------------------|----------------------|------------------------|-----------------|---------------|
| | | | Ref. Upper Limit | Ref. Lower Limit | Stopping Method | Accel Time 1 | Decel Time 1 | Quick Stop 0/1 | Action @ LL2/UL2 | S-Curve Accel at Start | S-Curve Accel at End | S-Curve Decel at Start | Motor Selection | V/F Selection |
| A1-04 | A1-04 | 5-Speed Multi-Step | 100.00 | 2.0 | 0 | 10.0 | 10.0 | 0 | 0 | 1.50 | 1.50 | 1.50 | 0 | 0F |
| | A1-04 | 2-Step Infinitely Variable | 100.00 | 2.0 | 0 | 10.0 | 10.0 | 0 | 0 | 1.50 | 1.50 | 1.50 | 0 | 0F |
| | A1-04 | 3-Step Infinitely Variable | 100.00 | 2.0 | 0 | 10.0 | 10.0 | 0 | 0 | 1.50 | 1.50 | 1.50 | 0 | 0F |
| | A1-04 | Uni-Polar Analog | 100.00 | 2.0 | 0 | 10.0 | 10.0 | 0 | 0 | 1.50 | 1.50 | 1.50 | 0 | 0F |
| | A1-04 | Bi-Polar Analog | 100.00 | 2.0 | 0 | 10.0 | 10.0 | 0 | 0 | 1.50 | 1.50 | 1.50 | 0 | 0F |
| | A1-04 | 2-Speed Multi-Step | 100.00 | 2.0 | 0 | 10.0 | 10.0 | 0 | 0 | 1.50 | 1.50 | 1.50 | 0 | 0F |
| | A1-04 | 3-Speed Multi-Step | 100.00 | 2.0 | 0 | 10.0 | 10.0 | 0 | 0 | 1.50 | 1.50 | 1.50 | 0 | 0F |
| | A1-04 | Not Used | 100.00 | 2.0 | 0 | 10.0 | 10.0 | 0 | 0 | 1.50 | 1.50 | 1.50 | 0 | 0F |

* Applies only for software versions 14910 and 14911.

Table 4-3: A1-03=Traverse (Continued)

| | Parameter | Description | H1-01 | H1-02 | H1-03 | H1-04 | H1-05 | H1-06 | H2-01 | H2-02 | H2-03 | H3-01 |
|-------|-----------|----------------------------|-------------------|-------------------|-------------------|-------------------|-------------------|-------------------|-------------------|--------------------|--------------------|--------------------|
| | | | Terminal 3 Select | Terminal 4 Select | Terminal 5 Select | Terminal 6 Select | Terminal 7 Select | Terminal 8 Select | Terminal 9 Select | Terminal 25 Select | Terminal 26 Select | Terminal 13 Signal |
| A1-04 | A1-04 | 5-Speed Multi-Step | 00 | 01 | 02 | 03 | 24 | 0E | 00 | 00 | 7F | 0 |
| | A1-04 | 2-Step Infinitely Variable | 05 | 07 | 09 | 13 | 24 | 0E | 00 | 00 | 7F | 0 |
| | A1-04 | 3-Step Infinitely Variable | 04 | 05 | 07 | 09 | 24 | 0E | 00 | 00 | 7F | 0 |
| | A1-04 | Uni-Polar Analog | 07 | 09 | 13 | 16 | 24 | 0E | 00 | 00 | 7F | 0 |
| | A1-04 | Bi-Polar Analog | 07 | 09 | 13 | 16 | 24 | 0E | 00 | 00 | 7F | 1 |
| | A1-04 | 2-Speed Multi-Step | 00 | 07 | 09 | 13 | 24 | 0E | 00 | 00 | 7F | 0 |
| | A1-04 | 3-Speed Multi-Step | 00 | 01 | 07 | 09 | 24 | 0E | 00 | 00 | 7F | 0 |
| | A1-04 | Not Used | 0F | 0F | 0F | 0F | 0F | 0F | 00 | 00 | 7F | 0 |

Table 4-4: A1-03=No Load Brake Hoist (Software Versions 14908-14911)

| Parameter | Description | B1-01 | B1-02 | B1-03 | B1-04 | B1-05 | B1-06* | B1-07* | B1-08* | B1-09 | B1-10 | |
|-----------|-------------|----------------------------|---------|---------|---------|---------|---------|---------|---------|---------------|--------------------|---|
| | | Speed 1 | Speed 2 | Speed 3 | Speed 4 | Speed 5 | Speed 6 | Speed 7 | Speed 8 | Jog Reference | Reference Priority | |
| A1-04 | A1-04 | 5-Speed Multi-Step | 6.00 | 15.00 | 30.00 | 45.00 | 60.00 | 9999 | 9999 | 9999 | 6.00 | 0 |
| | A1-04 | 2-Step Infinitely Variable | 6.00 | 9999 | 9999 | 9999 | 60.00 | 9999 | 9999 | 9999 | 6.00 | 0 |
| | A1-04 | 3-Step Infinitely Variable | 6.00 | 9999 | 9999 | 9999 | 60.00 | 9999 | 9999 | 9999 | 6.00 | 0 |
| | A1-04 | Uni-Polar Analog | 9999 | 9999 | 9999 | 9999 | 9999 | 9999 | 9999 | 9999 | 6.00 | 1 |
| | A1-04 | Bi-Polar Analog | 9999 | 9999 | 9999 | 9999 | 9999 | 9999 | 9999 | 9999 | 6.00 | 1 |
| | A1-04 | 2-Speed Multi-Step | 20.00 | 60.00 | 9999 | 9999 | 9999 | 9999 | 9999 | 9999 | 6.00 | 0 |
| | A1-04 | 3-Speed Multi-Step | 15.00 | 30.00 | 60.00 | 9999 | 9999 | 9999 | 9999 | 9999 | 6.00 | 0 |
| | A1-04 | Not Used | 15.00 | 30.00 | 60.00 | 9999 | 9999 | 9999 | 9999 | 9999 | 6.00 | 0 |

* Applies only for software versions 14910 and 14911.
 NOTE: Data 9999 denotes no change from previously programmed value.

Table 4-5: A1-03=No Load Brake Hoist (Continued)

| Parameter | Description | B2-01 | B2-02 | B3-03 | B5-01* | B5-02* | C1-01* | C3-07 | D9-01* | D9-02* | D9-03* | E1-02 | E1-03 | |
|-----------|-------------|----------------------------|------------------|-----------------|--------------|--------------|----------------|------------------|------------------------|----------------------|------------------------|-----------------|---------------|----|
| | | Ref. Upper Limit | Ref. Lower Limit | Stopping Method | Accel Time 1 | Decel Time 1 | Quick Stop 0/1 | Action @ LL2/UL2 | S-Curve Accel at Start | S-Curve Accel at End | S-Curve Decel at Start | Motor Selection | V/F Selection | |
| A1-04 | A1-04 | 5-Speed Multi-Step | 100.00 | 2.0 | 1 | 5.0 | 3.0 | 0 | 0 | 0.0 | 0.0 | 0.0 | 0 | 0F |
| | A1-04 | 2-Step Infinitely Variable | 100.00 | 2.0 | 1 | 5.0 | 3.0 | 0 | 0 | 0.0 | 0.0 | 0.0 | 0 | 0F |
| | A1-04 | 3-Step Infinitely Variable | 100.00 | 2.0 | 1 | 5.0 | 3.0 | 0 | 0 | 0.0 | 0.0 | 0.0 | 0 | 0F |
| | A1-04 | Uni-Polar Analog | 100.00 | 2.0 | 1 | 5.0 | 3.0 | 0 | 0 | 0.0 | 0.0 | 0.0 | 0 | 0F |
| | A1-04 | Bi-Polar Analog | 100.00 | 2.0 | 1 | 5.0 | 3.0 | 0 | 0 | 0.0 | 0.0 | 0.0 | 0 | 0F |
| | A1-04 | 2-Speed Multi-Step | 100.00 | 2.0 | 1 | 5.0 | 3.0 | 0 | 0 | 0.0 | 0.0 | 0.0 | 0 | 0F |
| | A1-04 | 3-Speed Multi-Step | 100.00 | 2.0 | 1 | 5.0 | 3.0 | 0 | 0 | 0.0 | 0.0 | 0.0 | 0 | 0F |
| | A1-04 | Not Used | 100.00 | 2.0 | 1 | 5.0 | 3.0 | 0 | 0 | 0.0 | 0.0 | 0.0 | 0 | 0F |

* Applies only for software versions 14910 and 14911.

Table 4-6: A1-03=No Load Brake Hoist (Continued)

| Parameter | Description | H1-01 | H1-02 | H1-03 | H1-04 | H1-05 | H1-06 | H2-01 | H2-02 | H2-03 | H3-01 | |
|-----------|-------------|----------------------------|-------------------|-------------------|-------------------|-------------------|-------------------|-------------------|--------------------|--------------------|--------------------|---|
| | | Terminal 3 Select | Terminal 4 Select | Terminal 5 Select | Terminal 6 Select | Terminal 7 Select | Terminal 8 Select | Terminal 9 Select | Terminal 25 Select | Terminal 26 Select | Terminal 13 Signal | |
| A1-04 | A1-04 | 5-Speed Multi-Step | 00 | 01 | 02 | 03 | 24 | 0E | 00 | 00 | 7F | 0 |
| | A1-04 | 2-Step Infinitely Variable | 05 | 07 | 09 | 13 | 24 | 0E | 00 | 00 | 7F | 0 |
| | A1-04 | 3-Step Infinitely Variable | 04 | 05 | 07 | 09 | 24 | 0E | 00 | 00 | 7F | 0 |
| | A1-04 | Uni-Polar Analog | 07 | 09 | 13 | 16 | 24 | 0E | 00 | 00 | 7F | 0 |
| | A1-04 | Bi-Polar Analog | 07 | 09 | 13 | 16 | 24 | 0E | 00 | 00 | 7F | 1 |
| | A1-04 | 2-Speed Multi-Step | 00 | 07 | 09 | 13 | 24 | 0E | 00 | 00 | 7F | 0 |
| | A1-04 | 3-Speed Multi-Step | 00 | 01 | 07 | 09 | 24 | 0E | 00 | 00 | 7F | 0 |
| | A1-04 | Not Used | 0F | 0F | 0F | 0F | 0F | 0F | 00 | 00 | 7F | 0 |

Parameters Changed by X-Press Programming (Software Version 14912)

Table 4-7: A1-03=Traverse

| | Parameter | Description | B1-01 | B1-02 | B1-03 | B1-04 | B1-05 | B1-06 | B1-07 | B1-08 | B1-09 | B1-10 |
|-------|-----------|----------------------------|---------|---------|---------|---------|---------|---------|---------|---------|---------------|--------------------|
| | | | Speed 1 | Speed 2 | Speed 3 | Speed 4 | Speed 5 | Speed 6 | Speed 7 | Speed 8 | Jog Reference | Reference Priority |
| A1-04 | A1-04 | 5-Speed Multi-Step | 6.00 | 15.00 | 30.00 | 45.00 | 60.00 | 9999 | 9999 | 9999 | 6.00 | 0 |
| | A1-04 | 2-Step Infinitely Variable | 6.00 | 9999 | 9999 | 9999 | 60.00 | 9999 | 9999 | 9999 | 6.00 | 0 |
| | A1-04 | 3-Step Infinitely Variable | 6.00 | 9999 | 9999 | 9999 | 60.00 | 9999 | 9999 | 9999 | 6.00 | 0 |
| | A1-04 | Uni-Polar Analog | 9999 | 9999 | 9999 | 9999 | 9999 | 9999 | 9999 | 9999 | 6.00 | 1 |
| | A1-04 | Bi-Polar Analog | 9999 | 9999 | 9999 | 9999 | 9999 | 9999 | 9999 | 9999 | 6.00 | 1 |
| | A1-04 | 2-Speed Multi-Step | 20.00 | 60.00 | 9999 | 9999 | 9999 | 9999 | 9999 | 9999 | 6.00 | 0 |
| | A1-04 | 3-Speed Multi-Step | 15.00 | 30.00 | 60.00 | 9999 | 9999 | 9999 | 9999 | 9999 | 6.00 | 0 |
| | A1-04 | Not Used | 15.00 | 30.00 | 60.00 | 9999 | 9999 | 9999 | 9999 | 9999 | 6.00 | 0 |

Note: Data 9999 denotes no change from previously programmed value.

Table 4-8: A1-03=Traverse (Continued)

| | Parameter | Description | B2-01 | B2-02 | B3-03 | B5-01 | B5-02 | C1-01 | C3-07 | C8-10 | D9-01 | D9-02 | D9-03 | E1-02 | E1-03 |
|-------|-----------|----------------------------|------------------|------------------|-----------------|--------------|--------------|----------------|------------------|-----------------|------------------------|----------------------|------------------------|-----------------|---------------|
| | | | Ref. Upper Limit | Ref. Lower Limit | Stopping Method | Accel Time 1 | Decel Time 1 | Quick Stop 0/1 | Action @ LL2/UL2 | Load Float Time | S-Curve Accel at Start | S-Curve Accel at End | S-Curve Decel at Start | Motor Selection | V/F Selection |
| A1-04 | A1-04 | 5-Speed Multi-Step | 100.00 | 2.0 | 0 | 10.0 | 10.0 | 0 | 0 | 0 | 1.50 | 1.50 | 1.50 | 0 | 0F |
| | A1-04 | 2-Step Infinitely Variable | 100.00 | 2.0 | 0 | 10.0 | 10.0 | 0 | 0 | 0 | 1.50 | 1.50 | 1.50 | 0 | 0F |
| | A1-04 | 3-Step Infinitely Variable | 100.00 | 2.0 | 0 | 10.0 | 10.0 | 0 | 0 | 0 | 1.50 | 1.50 | 1.50 | 0 | 0F |
| | A1-04 | Uni-Polar Analog | 100.00 | 2.0 | 0 | 10.0 | 10.0 | 0 | 0 | 0 | 1.50 | 1.50 | 1.50 | 0 | 0F |
| | A1-04 | Bi-Polar Analog | 100.00 | 2.0 | 0 | 10.0 | 10.0 | 0 | 0 | 0 | 1.50 | 1.50 | 1.50 | 0 | 0F |
| | A1-04 | 2-Speed Multi-Step | 100.00 | 2.0 | 0 | 10.0 | 10.0 | 0 | 0 | 0 | 1.50 | 1.50 | 1.50 | 0 | 0F |
| | A1-04 | 3-Speed Multi-Step | 100.00 | 2.0 | 0 | 10.0 | 10.0 | 0 | 0 | 0 | 1.50 | 1.50 | 1.50 | 0 | 0F |
| | A1-04 | Not Used | 100.00 | 2.0 | 0 | 10.0 | 10.0 | 0 | 0 | 0 | 1.50 | 1.50 | 1.50 | 0 | 0F |

Table 4-9: A1-03=Traverse (Continued)

| | Parameter | Description | H1-01 | H1-02 | H1-03 | H1-04 | H1-05 | H1-06 | H2-01 | H2-02 | H2-03 | H3-01 |
|-------|-----------|----------------------------|-------------------|-------------------|-------------------|-------------------|-------------------|-------------------|-------------------|--------------------|--------------------|--------------------|
| | | | Terminal 3 Select | Terminal 4 Select | Terminal 5 Select | Terminal 6 Select | Terminal 7 Select | Terminal 8 Select | Terminal 9 Select | Terminal 25 Select | Terminal 26 Select | Terminal 13 Signal |
| A1-04 | A1-04 | 5-Speed Multi-Step | 00 | 01 | 02 | 03 | 0F | 0F | 00 | 00 | 7F | 0 |
| | A1-04 | 2-Step Infinitely Variable | 05 | 0F | 0F | 0F | 0F | 0F | 00 | 00 | 7F | 0 |
| | A1-04 | 3-Step Infinitely Variable | 04 | 05 | 0F | 0F | 0F | 0F | 00 | 00 | 7F | 0 |
| | A1-04 | Uni-Polar Analog | 0F | 0F | 0F | 0F | 0F | 0F | 00 | 00 | 7F | 0 |
| | A1-04 | Bi-Polar Analog | 0F | 0F | 0F | 0F | 0F | 0F | 00 | 00 | 7F | 1 |
| | A1-04 | 2-Speed Multi-Step | 00 | 0F | 0F | 0F | 0F | 0F | 00 | 00 | 7F | 0 |
| | A1-04 | 3-Speed Multi-Step | 00 | 01 | 0F | 0F | 0F | 0F | 00 | 00 | 7F | 0 |
| | A1-04 | Not Used | 0F | 0F | 0F | 0F | 0F | 0F | 00 | 00 | 7F | 0 |

Table 4-10: A1-03=No Load Brake Hoist(Software Versions 14912)

| Parameter | Description | B1-01 | B1-02 | B1-03 | B1-04 | B1-05 | B1-06* | B1-07* | B1-08* | B1-09 | B1-10 | |
|-----------|-------------|----------------------------|---------|---------|---------|---------|---------|---------|---------|---------------|--------------------|---|
| | | Speed 1 | Speed 2 | Speed 3 | Speed 4 | Speed 5 | Speed 6 | Speed 7 | Speed 8 | Jog Reference | Reference Priority | |
| A1-04 | A1-04 | 5-Speed Multi-Step | 6.00 | 15.00 | 30.00 | 45.00 | 60.00 | 9999 | 9999 | 9999 | 6.00 | 0 |
| | A1-04 | 2-Step Infinitely Variable | 6.00 | 9999 | 9999 | 9999 | 60.00 | 9999 | 9999 | 9999 | 6.00 | 0 |
| | A1-04 | 3-Step Infinitely Variable | 6.00 | 9999 | 9999 | 9999 | 60.00 | 9999 | 9999 | 9999 | 6.00 | 0 |
| | A1-04 | Uni-Polar Analog | 9999 | 9999 | 9999 | 9999 | 9999 | 9999 | 9999 | 9999 | 6.00 | 1 |
| | A1-04 | Bi-Polar Analog | 9999 | 9999 | 9999 | 9999 | 9999 | 9999 | 9999 | 9999 | 6.00 | 1 |
| | A1-04 | 2-Speed Multi-Step | 20.00 | 60.00 | 9999 | 9999 | 9999 | 9999 | 9999 | 9999 | 6.00 | 0 |
| | A1-04 | 3-Speed Multi-Step | 15.00 | 30.00 | 60.00 | 9999 | 9999 | 9999 | 9999 | 9999 | 6.00 | 0 |
| | A1-04 | Not Used | 15.00 | 30.00 | 60.00 | 9999 | 9999 | 9999 | 9999 | 9999 | 6.00 | 0 |

NOTE: Data 9999 denotes no change from previously programmed value.

Table 4-11: A1-03=No Load Brake Hoist (Continued)

| Parameter | Description | B2-01 | B2-02 | B3-03 | B5-01* | B5-02* | C1-01* | C3-07 | C8-10 | D9-01* | D9-02* | D9-03* | E1-02 | E1-03 | |
|-----------|-------------|----------------------------|------------------|-----------------|--------------|--------------|----------------|-------------------|-----------------|------------------------|----------------------|------------------------|-----------------|---------------|----|
| | | Ref. Upper Limit | Ref. Lower Limit | Stopping Method | Accel Time 1 | Decel Time 1 | Quick Stop 0/1 | Action @ LL2/ UL2 | Load Float Time | S-Curve Accel at Start | S-Curve Accel at End | S-Curve Decel at Start | Motor Selection | V/F Selection | |
| A1-04 | A1-04 | 5-Speed Multi-Step | 100.00 | 2.0 | 6 | 5.0 | 3.0 | 1 | 0 | 10 | .50 | .50 | .50 | 0 | 0F |
| | A1-04 | 2-Step Infinitely Variable | 100.00 | 2.0 | 6 | 5.0 | 3.0 | 1 | 0 | 10 | .50 | .50 | .50 | 0 | 0F |
| | A1-04 | 3-Step Infinitely Variable | 100.00 | 2.0 | 6 | 5.0 | 3.0 | 1 | 0 | 10 | .50 | .50 | .50 | 0 | 0F |
| | A1-04 | Uni-Polar Analog | 100.00 | 2.0 | 6 | 5.0 | 3.0 | 1 | 0 | 10 | .50 | .50 | .50 | 0 | 0F |
| | A1-04 | Bi-Polar Analog | 100.00 | 2.0 | 6 | 5.0 | 3.0 | 1 | 0 | 10 | .50 | .50 | .50 | 0 | 0F |
| | A1-04 | 2-Speed Multi-Step | 100.00 | 2.0 | 6 | 5.0 | 3.0 | 1 | 0 | 10 | .50 | .50 | .50 | 0 | 0F |
| | A1-04 | 3-Speed Multi-Step | 100.00 | 2.0 | 6 | 5.0 | 3.0 | 1 | 0 | 10 | .50 | .50 | .50 | 0 | 0F |
| | A1-04 | Not Used | 100.00 | 2.0 | 6 | 5.0 | 3.0 | 1 | 0 | 10 | .50 | .50 | .50 | 0 | 0F |

Table 4-12: A1-03=No Load Brake Hoist (Continued)

| Parameter | Description | H1-01 | H1-02 | H1-03 | H1-04 | H1-05 | H1-06 | H2-01 | H2-02 | H2-03 | H3-01 | |
|-----------|-------------|----------------------------|-------------------|-------------------|-------------------|-------------------|-------------------|-------------------|--------------------|--------------------|--------------------|---|
| | | Terminal 3 Select | Terminal 4 Select | Terminal 5 Select | Terminal 6 Select | Terminal 7 Select | Terminal 8 Select | Terminal 9 Select | Terminal 25 Select | Terminal 26 Select | Terminal 13 Signal | |
| A1-04 | A1-04 | 5-Speed Multi-Step | 00 | 01 | 02 | 03 | 0F | 0F | 00 | 00 | 7F | 0 |
| | A1-04 | 2-Step Infinitely Variable | 05 | 0F | 0F | 0F | 0F | 0F | 00 | 00 | 7F | 0 |
| | A1-04 | 3-Step Infinitely Variable | 04 | 05 | 0F | 0F | 0F | 0F | 00 | 00 | 7F | 0 |
| | A1-04 | Uni-Polar Analog | 0F | 0F | 0F | 0F | 0F | 0F | 00 | 00 | 7F | 0 |
| | A1-04 | Bi-Polar Analog | 0F | 0F | 0F | 0F | 0F | 0F | 00 | 00 | 7F | 1 |
| | A1-04 | 2-Speed Multi-Step | 00 | 0F | 0F | 0F | 0F | 0F | 00 | 00 | 7F | 0 |
| | A1-04 | 3-Speed Multi-Step | 00 | 01 | 0F | 0F | 0F | 0F | 00 | 00 | 7F | 0 |
| | A1-04 | Not Used | 0F | 0F | 0F | 0F | 0F | 0F | 00 | 00 | 7F | 0 |

Initial Parameters (A1-05)

Use this parameter to reset the inverter to its factory default settings.

| Setting | Description |
|----------------|--|
| 0 | No Initialization (factory default) |
| 1110 | User Initialization - resets the inverter to user-specified initial values. To set user-specified initial values, make all required changes to parameter settings, then set 02-03 to "1". The inverter will memorize all current settings as the user-specified initial values. Up to 50 changed parameters can be stored. |

Password Entry (A1-06)

This parameter will enable the user to set a password that will inhibit the programming of the *A1-01* to *A1-03* parameters. This function is useful when used in conjunction with the access level parameter *A1-01*. To set the password, press the MENU and RESET buttons at the same time and the display will change from *A1-06* to *A1-07*. Program in a password number, then when *A1-06* is not the same as *A1-07* parameter *A1-01* to *A1-03* cannot be changed. When *A1-06* is the same as *A1-07*, then *A1-01* to *A1-03* can be changed.

User Parameters (A2-01 through 30)

The user can select up to 30 parameters for quick-access programming. By setting the user access level (*A1-01*) to "User Program," only the parameters selected in function A2 can be accessed by the user. To assign a parameter as a user parameter go to the A2 level in the initialize menu. Once the A2 parameters are set and *A1-01* is programmed to "User Program," only the parameters visible in the program menu will be assigned to an A2 parameter.

Auto-Tuning



CAUTION

The brake output is not energized during auto-tune. The brake must be manually released and unreleased when Auto-Tuning is complete.



WARNING

Auto-tuning should only be performed on a motor that is not coupled to a gearbox.

The IMPULSE•VG+ Series 2 can adapt to all motors manufactured worldwide with its automatic tuning function. The inverter asks the user for minimal motor information, then guides the user through a quick simple tuning process. Refer to the Structure of Parameters on page 4-7 and the table below for the motor data required for automatic tuning.

NOTE: Contact Electromotive Systems service department if an auto-tune can not be performed.

| Display | Description | Default Setting |
|-----------------|-------------------------------------|-----------------|
| Rated Voltage | Sets motor rated voltage in VAC | KVA dependent |
| Rated Current | Sets motor rated current in Amps | KVA dependent |
| Rated Frequency | Sets motor rated frequency in Hertz | 60.0 Hz |
| Rated Speed | Sets motor rated speed in RPM | 1750 RPM |
| Number of Poles | Sets the number of motor poles | 4 |
| Select Motor | Selects between motor 1 or 2 | 1 |
| PG Pulses/Rev | Sets encoder PPR | 1024 PPR |

After scrolling through the tuning parameters using the Up Arrow key, depress the RUN key to begin auto-tuning. During tuning, “Tuning Proceeding” flashes on the digital operator display. When complete, “Tune Successful”, is displayed. Depress the Menu key to exit auto-tuning mode. Please refer to the “Fault Display and Corrective Actions at Auto-Tuning” section on page 6-19 if “Tune Successful” is not displayed.

NOTE: If the STOP key is depressed during tuning, auto-tuning is interrupted and the motor coasts to a stop. The data changed during tuning returns to its original values.

NOTE: If an auto-tune is unsuccessful, temporarily change D12-30=1 and D10-01 to at least 5.0KHz.

c h a p t e r **5**

**Programming Advanced
Features**

This page intentionally left blank.

Application

- B1 Preset References
- B2 Reference Limits
- B3 Sequence/Reference Source
- B4 Trim Control Level
- B5 Acceleration/Deceleration
- B6 Phase Loss Detection
- B8 Jump Frequencies

Preset Reference

| Parmtr Code | Display | Function | Range | Initial Value | V/F Access | Open Loop Vector Access |
|-------------|---|---|----------------|---------------|------------|-------------------------|
| B1-01* | Reference 1 | Sets the frequency of Minimum Speed/Speed 1. | 0.00–150.00 Hz | 15.00 | Adv | Adv |
| B1-02* | Reference 2 | Sets the Speed 2 frequency. | 0.00–150.00 Hz | 30.00 | Adv | Adv |
| B1-03* | Reference 3 | Sets the Speed 3 frequency. | 0.00–150.00 Hz | 60.00 | Adv | Adv |
| B1-04* | Reference 4 | Sets the Speed 4 frequency. | 0.00–150.00 Hz | 45.00 | Adv | Adv |
| B1-05* | Reference 5 | Sets the Speed 5 frequency. | 0.00–150.00 Hz | 60.00 | Adv | Adv |
| B1-06** | *Reference 6 | Sets the Speed 6 frequency. | 0.00–150.00 Hz | 0.00 | Adv | Adv |
| B1-07** | *Reference 7 | Sets the Speed 7 frequency. | 0.00–150.00 Hz | 0.00 | Adv | Adv |
| B1-08** | *Reference 8 | Sets the Speed 8 frequency. | 0.00–150.00 Hz | 0.00 | Adv | Adv |
| B1-09* | Jog Reference | Jog Control and Inching Control frequency reference. | 0.00–150.00 Hz | 6.00 | Adv | Adv |
| B1-10* | Ref Priority 0 Digital Ref Only 1 Analog Ref Only 2 Higher Ref Sel | Determines whether the digital or analog frequency reference is used. NOTE: When using Higher Reference Select, 2-Step Infinitely Variable should NOT be used for a Speed Reference setting in parameter A1-04. The two functions are not intended to work in conjunction. | | 0 | Adv | Adv |

* Initial value is determined by X-Press Programming (Table 4.1-4.12)

** Does not apply to software versions 14908-14909.

Table 5.1: 1-9 Step Multi-Step (Software Versions 14910-14912)

| Speed Reference | Forward/Reverse | Multi-Step Speed 2 | Multi-Step Speed 3 | Multi-Step Speed 4 | Multi-Step Speed 5 |
|------------------------|------------------------|---------------------------|---------------------------|---------------------------|---------------------------|
| STOP | 0 | — | — | — | — |
| B1-01 | 1 | 0 | 0 | 0 | 0 |
| B1-02 | 1 | 1 | 0 | 0 | 0 |
| B1-03 | 1 | 1 | 1 | 0 | 0 |
| B1-04 | 1 | 1 | 1 | 1 | 0 |
| B1-05 | 1 | 1 | 1 | 1 | 1 |
| B1-06 | 1 | 0 | 1 | 0 | 0 |
| B1-07 | 1 | 0 | 1 | 1 | 0 |
| B1-08 | 1 | 0 | 0 | 1 | 0 |
| B1-09 | 1 | 1 | 0 | 1 | 0 |

0 = Open or Not Selected

1 = Closed

— = Not Applicable

Reference Limits

These parameters will limit the frequency range as a percentage of maximum output frequency (E1-04). However, if the lower limit is below the zero speed level (D1-01), then operation will continue according to B3-05.

An alternate upper limit frequency can be used during operation when a Multi-Function Input (MFI) is set to 43 (Alt S-Ref UpLimit) and the MFI is on. Alternate Upper Limit Frequency = (B2-03)% x (E1-04).

| Parmtr Code | Display | Function | Range | Initial Value | V/F Access | Open Loop Vector Access |
|-------------|-----------------|---|----------|---------------|------------|-------------------------|
| B2-01 | Ref Upper Limit | Sets as a percentage of the maximum output frequency (E1-04), which determines the maximum frequency at which the drive is able to run. | 0.0–110% | 100.0 | Adv | Adv |
| B2-02 | Ref Lower Limit | Sets as a percentage of the maximum output frequency (E1-04), which determines the minimum frequency at which the drive is able to run. | 0.0–109% | 2.0 | Adv | Adv |
| B2-03 | Upper Lim Gain | A multiplier, sets an alternate upper limit frequency by a multi-function input = 43 | 0–255% | 100 | Adv | Adv |

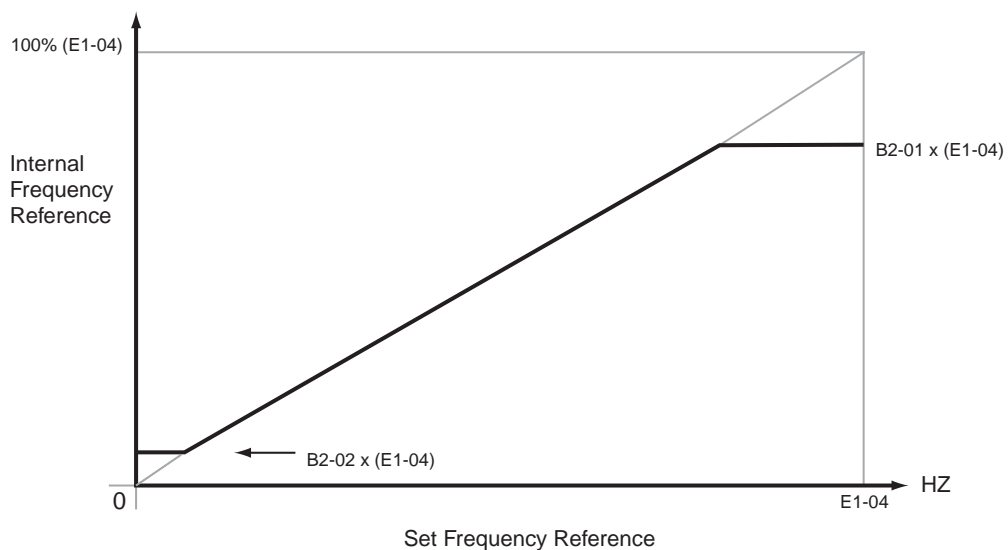

Figure 5-1: Setting Frequency Upper and Lower Limits

Sequence/Reference Source

B3-01 and B3-02 determine the source from where the frequency reference and RUN command are generated.

| Parmtr Code | Display | Function | Range | Initial Value | Access Level |
|--------------------|------------------|---|--------------|----------------------|---------------------|
| B3-01 | Reference Source | Source from where the frequency reference is generated. | | 1 | Adv |
| | 0 Operator | Digital operator (Keypad). | | | |
| | 1 Terminals | Control circuit terminal (G5IF card). | | | |
| | 2 Serial Com | Serial communication (Port 6CN). | | | |
| | 3 Option PCB | Optional card (Port 2CN). | | | |
| B3-02 | Run Source | Source from where the RUN command is generated. | | 1 | Adv |
| | 0 Operator | Digital operator (Keypad). | | | |
| | 1 Terminals | Control circuit terminal (G5IF card). | | | |
| | 2 Serial Com | Serial communication (Port 6CN). | | | |
| | 3 Option PCB | Optional card (Port 2CN). | | | |

Stop Method

B3-03 selects the stopping method suitable for the particular application.

| Parmtr Code | Display | Function | Range | Initial Value | Access Level |
|-------------|--|-------------------------|-------|---------------|--------------|
| B3-03 | Stop Method | Determines stop method. | | * | Adv |
| | 0 Ramp to Stop (A1-03=0) | (Fig 5-2) | | | |
| | 1 Coast to Stop (A1-03=1) | (Fig 5-3) | | | |
| | 4 Ramp with timer (Traverse mode only) | Fig (5-4) | | | |
| | 6 No Load Brake (A1-03=2) (See No-Load Brake Start/Stop) | | | | |

* Initial value is determined by X-Press Programming (Table 4.1-4.12)

Ramp to Stop (B3-03=0)

Upon removal of the FWD or REV run command, the motor decelerates at a rate determined by the time set in deceleration time 1 (B5-02) and DC injection braking is applied after the DC injection start frequency D1-01 has been reached. If the deceleration time is set too short or the load inertia is large, an overvoltage fault (OV) may occur during deceleration. In this case, increase the deceleration time or install an optional braking transistor and/or braking resistor.

Braking torque: without braking resistor, approximately 20% of motor rated torque; with braking option, approximately 150% of motor rated torque.

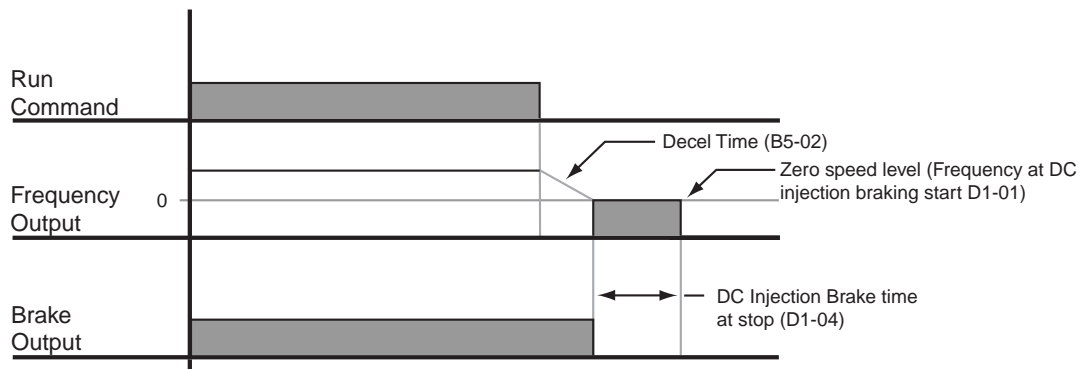

Figure 5-2: Ramp to Stop

Coast to Stop (B3-03=1)

Upon removal of the FWD or REV run command, the motor starts to coast and the electric brake sets.

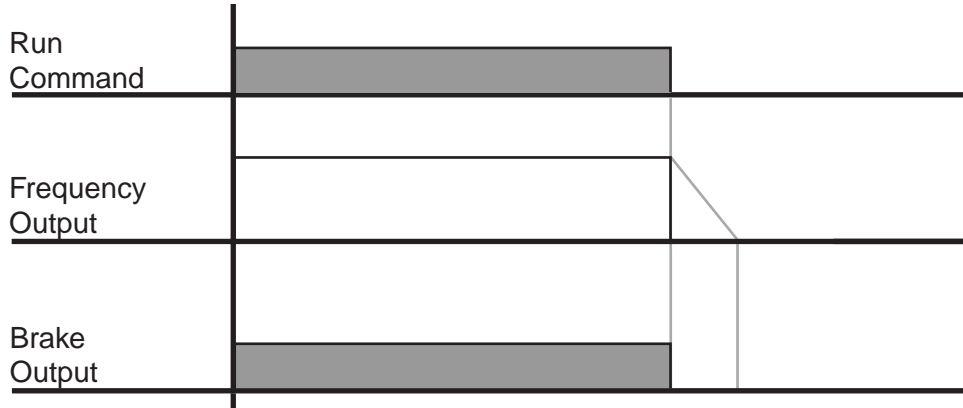

Figure 5-3: Coast to Stop

Ramp w/Timer (B3-03=4)

(This option is only available in traverse motion). Upon run command removal, the motor decelerates to stop. The brake delays for a time interval (C12-02) before it is set. This option reduces brake wear for applications that involve frequent stopping and starting.

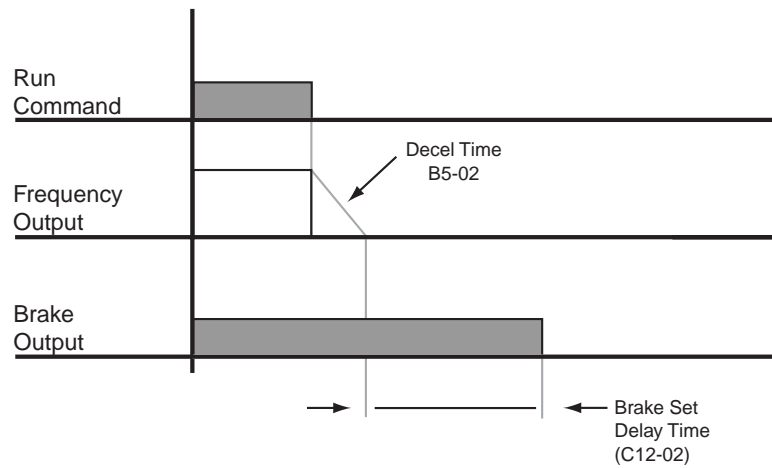

Figure 5-4: Ramp w/Timer

Zero-Speed Operation

This parameter sets the speed reference level at which Zero Speed mode operation will activate, in accordance with the selection programmed B3-05 (see the figures below).

| Parmtr Code | Display | Function | Range | Initial Value | Access Level |
|-------------|----------------------------|--|-------|---------------|--------------|
| B3-05 | Zero-Speed Oper | Operation Selection at Zero Speed. | | 0 | Adv |
| | 0 RUN at Freq Ref | Operate according to the Frequency Reference | | | |
| | 1 Stop | Coast when the Frequency Reference is below E1-09 | | | |
| | 2 RUN at Min. Freq (E1-09) | Output the Frequency set in E1-09 | | | |
| | 3 RUN at Zero RPM | Zero reference value when the frequency reference is below E1-09 | | | |

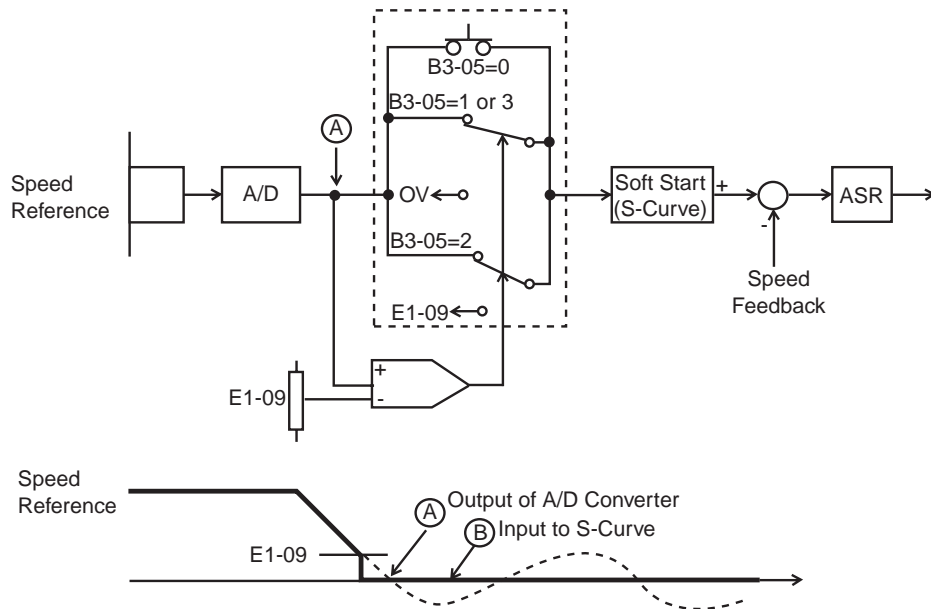

Figure 5-5: ASR Output with Analog Input

B3-05: 0 Run at Frequency Reference

E1-09: (Minimum Output Frequency) ineffective

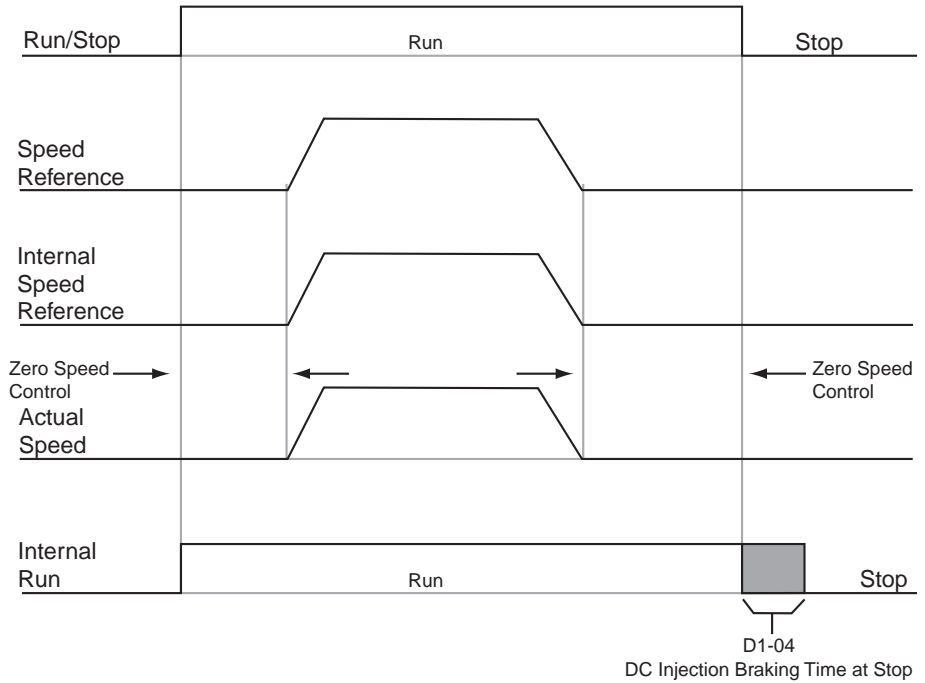

Figure 5-6: B3-05: 0 Run at Frequency Reference

B3-05: 1 STOP

E1-09: (Minimum Output Frequency) effective

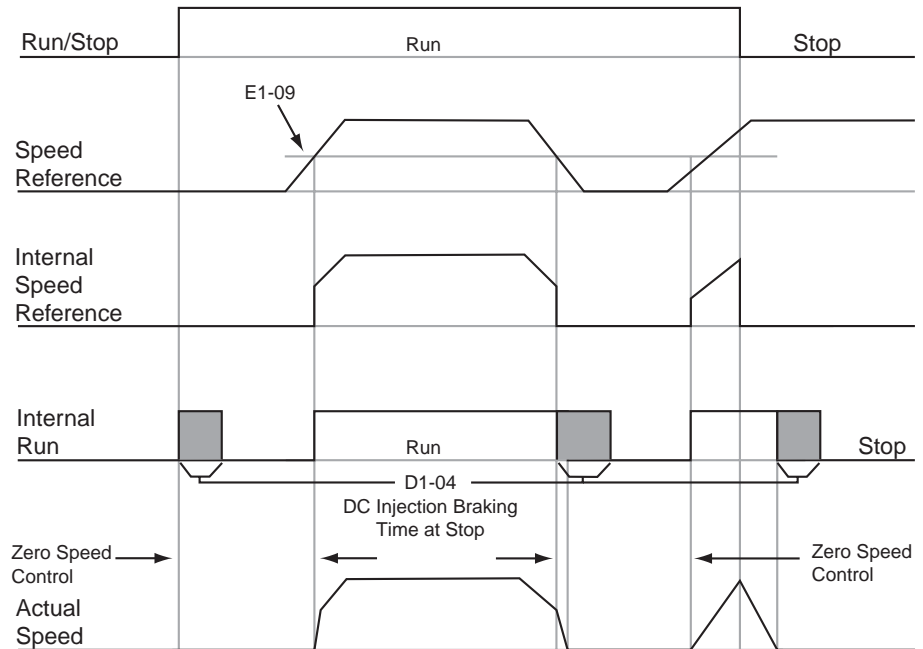

Figure 5-7: B3-05: 1 STOP

B3-05: 2 Run at Minimum Frequency

E1-09: (Minimum Output Frequency) effective

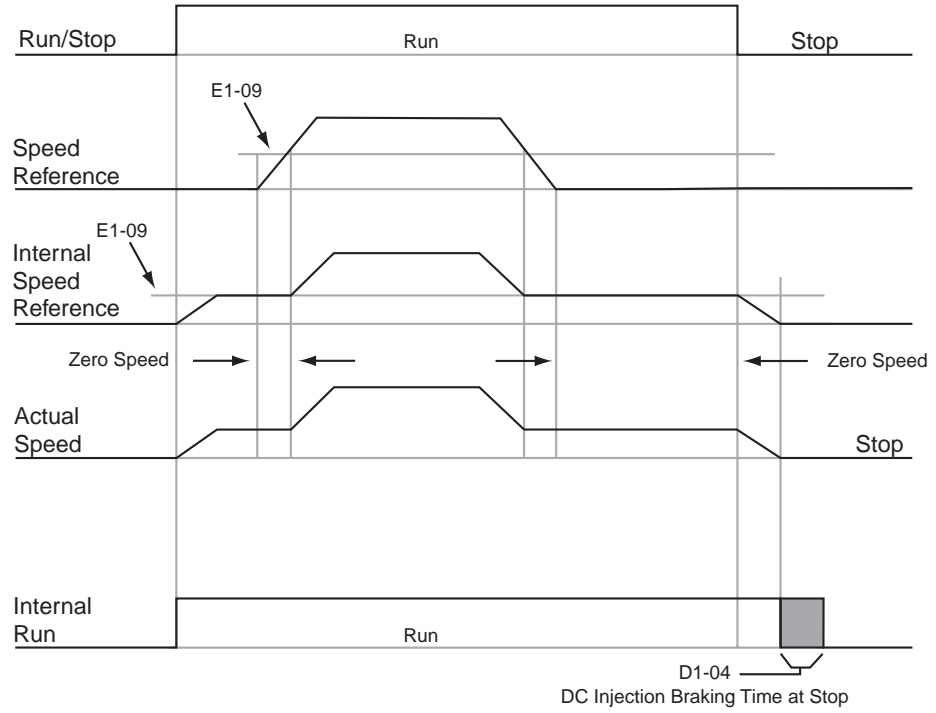

Figure 5-8: B3-05: 2 Run at Minimum Frequency

B3-05: 3 Run at Zero RPM

E1-09: (Minimum Output Frequency) effective

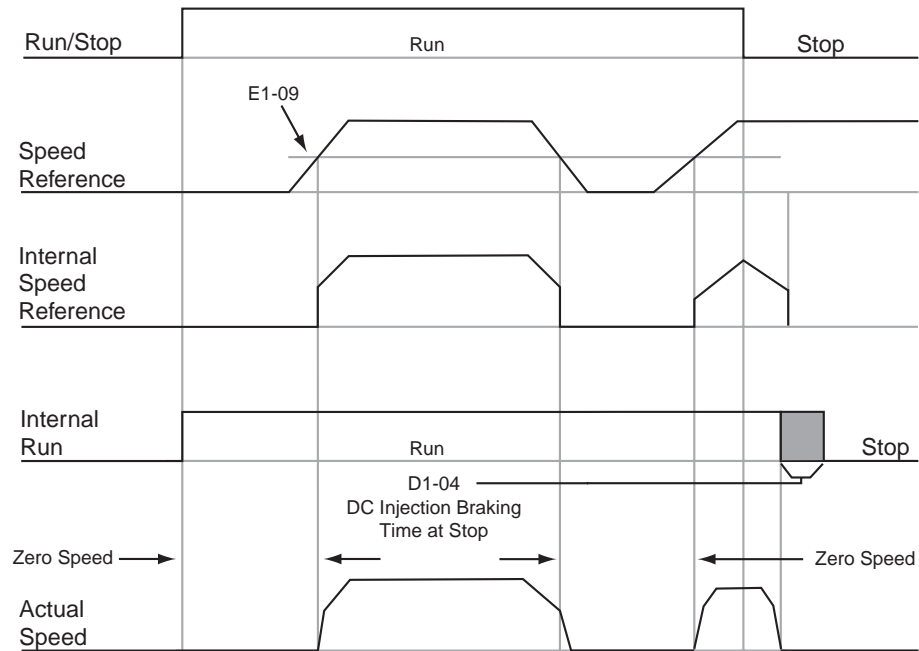

Figure 5-9: B3-05: 3 Run at Zero RPM

Input Scan Time

B3-06 selects the microprocessor scan time for reading sequence input data from the control circuit terminals. Set B3-06 to “0” when a quicker response is needed from the control circuit terminal.

| Parmtr Code | Display | Function | Range | Initial Value | V/F Access | Open Loop Vector Access |
|--------------------|------------------|--------------------------------------|--------------|----------------------|-------------------|--------------------------------|
| B3-06 | # of Input Scans | Selects the microprocessor scan time | | 1 | Adv | Adv |
| | 0 | <i>2ms–2 scans</i> | | | | |
| | 1 | <i>5ms–2 scans</i> | | | | |

LOC/REM Run Select

If the run reference/speed reference are switched between serial mode and drive terminal mode, B3-07 determines action after the switch.

| Parmtr Code | Display | Function | Range | Initial Value | V/F Access | Open Loop Vector Access |
|--------------------|-----------------|---|--------------|----------------------|-------------------|--------------------------------|
| B3-07 | LOC/REM Run Sel | Determines action after switching Run/Speed reference source. | | 0 | Adv | Adv |
| | 0 | <i>Cycle Extrn Run</i> | | | | |
| | | If the run command is present at the time when the Run/Speed reference source is switched, it requires the run command to be removed and then reapply the run command from the new source to resume the normal operation. | | | | |
| | 1 | <i>Accep Extrn Run</i> | | | | |
| | | If the run command is present at the time when the Run/Speed reference source is switched, it does not require the run command from the new source to be removed. The normal operation will continue. | | | | |

Trim Control Level

The trim control level is valid when the trim control increase command (setting: 34) or trim control decrease command (setting: 35) is set for a multi-function input (H1-01 to H1-06).

If the trim control increase command is ON when a frequency reference is input on the analog input, the trim control level will be added to the analog frequency reference and then that sum will be output as the output frequency. If the trim control decrease command is ON, the frequency reference will be decreased by the trim control level.

| Parmtr Code | Display | Function | Range | Initial Value | Access Level |
|--------------------|------------------|-------------------------------|--------------|----------------------|---------------------|
| B4-02 | Trim Control LVL | Sets Trim Control speed level | 0–100% | 10 | Adv |

Set the trim control level as a percentage of the maximum output frequency.

If the frequency reference minus the trim control level is less than zero, the output frequency will be zero.

Acceleration/Deceleration

Acceleration time sets the time necessary for the output frequency to accelerate from 0Hz to maximum output frequency (E1-04). Deceleration time sets the time necessary for the output frequency to decelerate from the maximum output frequency (E1-04) to 0Hz.

| Parmtr Code | Display | Function | Range | Initial Value | Access Level |
|-------------|--------------|---|----------------|---------------|--------------|
| B5-01* | Accel Time 1 | Sets acceleration time. | 0.0–25.5 sec | 5.0 | Adv |
| B5-02* | Decel Time 1 | Sets deceleration time. | 0.0–25.5 sec | 3.0 | Adv |
| B5-03 | Accel Time 2 | Sets alternate accel. time. Enabled by multifunction input=1B. | 0.0–6000.0 sec | 1.0 | Adv |
| B5-04 | Decel Time 2 | Sets alternate decel. time. Enabled by multi-function input=1B. | 0.0–6000.0 sec | 1.0 | Adv |

* Initial value is determined by X-Press Programming (Table 4.1 to 4.12).

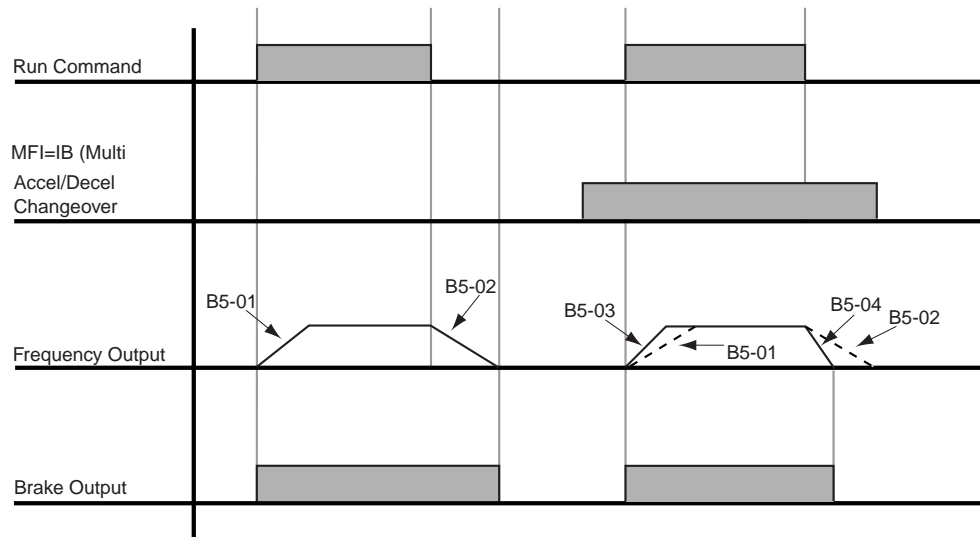

NOTE: Assume the constant B3-03 is set to "0" (Ramp to Stop).

Figure 5-10: Normal Accel/Decel Time and Multiple Accel/Decel Changeover

Accel/Decel Time Switching Frequency

Accel/Decel times can be changed automatically without using multi-function inputs. When multi-function contact inputs are set for Accel/Decel selection, this command has priority over automatic change of Accel/Decel.

| Parmtr Code | Display | Function | Range | Initial Value | Access Level |
|--------------------|------------------------------------|--|--------------|----------------------|---------------------|
| B5-05 | Accel Time N Chg | Sets acceleration time at Speed Switch frequency. | 0.0–25.5 sec | 1.0 | Adv |
| B5-06 | Dec Time N Chg | Sets deceleration time at Speed Switch frequency. | 0.0–25.5 sec | 1.0 | Adv |
| B5-07 | Hoist 2 Stop | Sets deceleration time for DOWN/REVERSE direction, when B3-03=5 (Hoist 2-Stop). | 0.0–25.5 sec | 0.3 | Adv |
| B5-08 | Fault Stop Time | Sets deceleration time for complete stop at external fault. See External Response Selection page 5-89. | 0.0–25.5 sec | 0.3 | Adv |
| B5-09 | Acc/Dec Units | Determines acceleration and deceleration time interval and range. | | 1 | Adv |
| | <i>0 0.01sec for 0.00–2.55 sec</i> | | | | |
| | <i>1 0.1sec for 0.0–25.5</i> | | | | |
| B5-10 | Acc/Dec SW Freq | Determines acceleration/ deceleration switching level | 0.0–150.0Hz | 120.0 | Adv |
| B5-11 | SW Freq Compare | Determines when Acceleration Time and Deceleration Time at Speed Switch Hz is enabled; | | 1 | Adv |
| | <i>0 lower SW Freq</i> | 0: B5-05/06 is enabled, N-out≤B5-10 | | | |
| | <i>1 upper SW Freq</i> | 1: B5-05/06 is enabled, N-out≥B5-10 | | | |

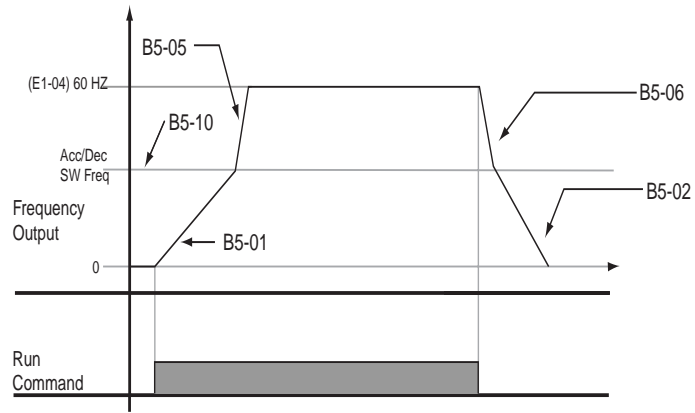

Figure 5-11: When B5-11=1 (Upper Switch Frequency)

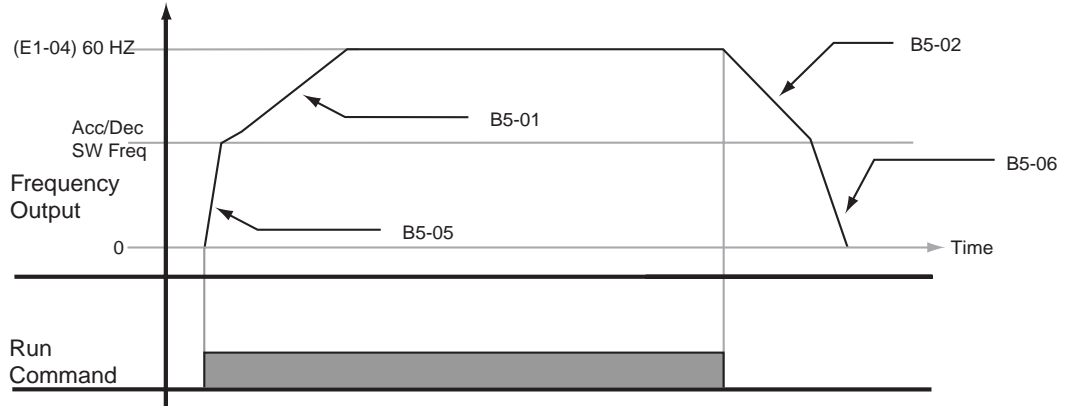

Figure 5-12: B5-11=0 (Lower Switch Frequency)

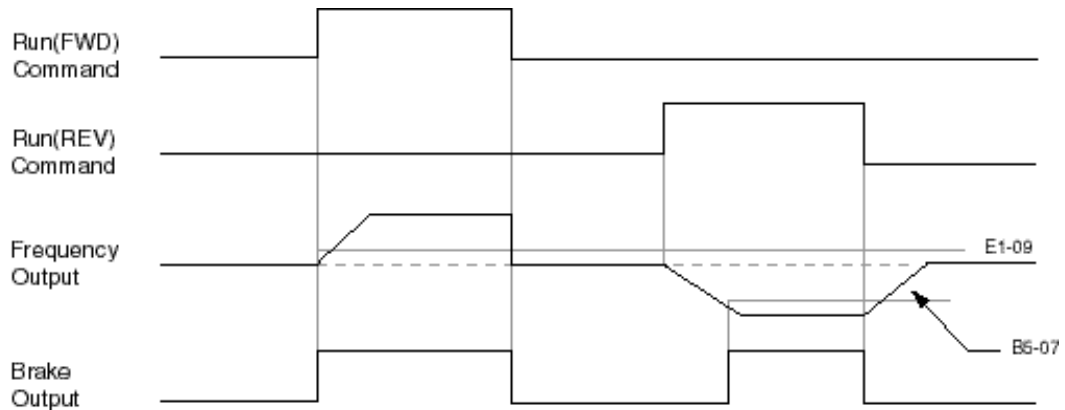

Figure 5-13: B5-07 = 3 (Hoist 2-Stop)

Torque Limit Accel/Decel

Determines Accel/Decel times when the multi-function input H1-01~H1-06 = 14 (Torque Limit Accel/Decel) is on.

| Parmtr Code | Display | Function | Range | Initial Value | Access Level |
|--------------------|-----------------|---|--------------|----------------------|---------------------|
| B5-12 | For T Lim Accel | Determines acceleration time at FORWARD when Torque Limit Acc/Dec is multi-function input = 14. | 0.0–25.5 sec | 0 | Adv |
| B5-13 | For T Lim Decel | Determines deceleration time at FORWARD when Torque Limit Acc/Dec is multi-function input = 14. | 0.0–25.5 sec | 0 | Adv |
| B5-14 | Rev T Lim Accel | Determines acceleration time at REVERSE when Torque Limit Acc/Dec is multi-function input = 14. | 0.0–25.5 sec | 0.5 | Adv |
| B5-15 | Rev T Lim Decel | Determines deceleration time at REVERSE when Torque Limit Acc/Dec is multi-function input = 14. | 0.0–25.5 sec | 0 | Adv |

Phase Loss Detection

Input Phase Loss Detection is provided to protect the main power rectifiers and capacitors in the IMPULSE•VG+ Series 2. If any of the three-phase input lines are lost, the DC Bus capacitors and rectifiers suffer approximately a 40% increase in current. This increase will cause a ripple on the DC Bus voltage. If this ripple becomes too great or one of the input phases is lost, the drive automatically shuts down and displays a fault code “PF”.

NOTE: When DC power is applied through the (+) and (-) terminals, input phase loss detection is disabled.

Output Phase Loss Detection compares the output current of each of the three phases to a preset level. If the output current of one phase falls below B6-04, a “LF” fault will appear on the display. The drive will immediately set the brake, thus retaining control of the load.

| Parmtr Code | Display | Function | Range | Initial Value | Access Level |
|--------------------|--|--|--------------|----------------------|---------------------|
| B6-01 | Ph Loss In Sel <i>0 Disabled</i> <i>1 Enabled</i> | Determines whether Phase Loss Detection Input is enabled. | | 0 | Adv |
| B6-02 | Ph Loss In Lvl | Determines Phase Loss Detection Input Level. | 0.0–25.0% | 7.5 | Adv |
| B6-03 | Ph Loss Out Sel <i>0 Disabled</i> <i>1 Enabled</i> | Determines whether Phase Loss Detection Output is enabled. | | 1 | Adv |
| B6-04 | Ph Loss Out Lvl | Determines Phase Loss Detection Output level. | 0.0–20.0% | 5.0 | Adv |

SVR (Speed Variation Error)

Increasing B7-01 decreases sensitivity to “noise” in the encoder circuit.

| Parmtr Code | Display | Function | Range | Initial Value | Access Level |
|--------------------|-----------------|----------------------------------|--------------|----------------------|---------------------|
| B7-01 | SVR Delay Timer | “Noisy” Encoder Signal Detection | 0–2000ms | 70 | Adv |

Jump Frequencies

This function allows the “jumping” of critical frequencies so that the motor can operate without resonant vibrations caused by some machine systems. This function is also used for deadband control. Setting the value to 0.0 Hz disables this function.

| Parmtr Code | Display | Function | Range | Initial Value | Access Level |
|-------------|----------------|-------------------------------------|--------------|---------------|--------------|
| B8-01 | Jump Freq 1 | First of three jump frequencies. | 0.0–150.0 Hz | 0.0 | Adv |
| B8-02 | Jump Freq 2 | Second of three jump frequencies. | 0.0–150.0 Hz | 0.0 | Adv |
| B8-03 | Jump Freq 3 | Third of three jump frequencies. | 0.0–150.0 Hz | 0.0 | Adv |
| B8-04 | Jump Bandwidth | Jump frequency reference bandwidth. | 0.0–20.0 Hz | 1.0 | Adv |

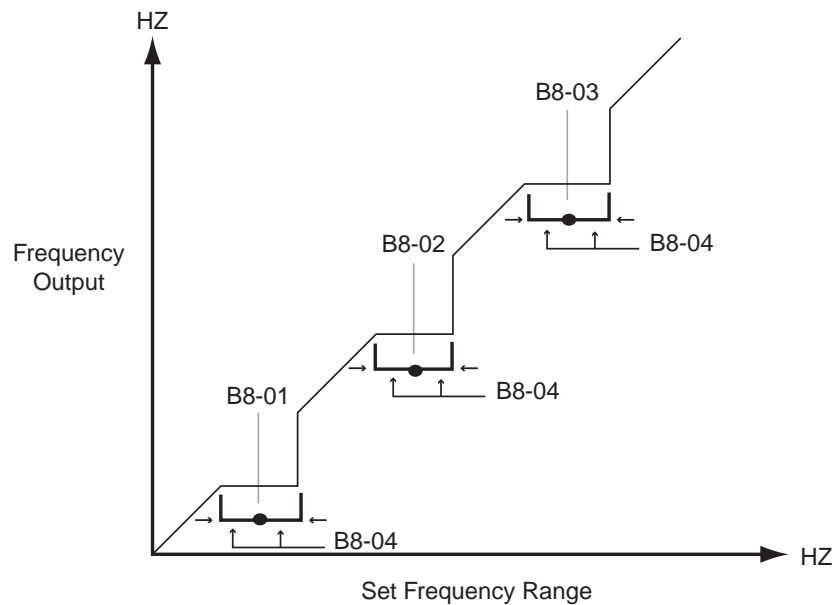

Figure 5-14: Jump Frequencies

Special Functions

- C1 Quick Stop/Reverse Plug Simulation
- C2 Micro-Positioning Control Multiplier
- C3 End of Travel Limit
- C4 Zero Servo
- C5 Load Check
- C6 Ultra-Lift
- C7 Torque Limit
- C8 No Load Brake
- C9 G5IN4 Setup
- C10 Weight Measurement
- C11 Slack Cable Detection
- C12 Delay Timers
- C13 Inching Control

| Special Function | Motion (A1-03) | |
|--|--------------------|-------------------------|
| | Traverse (A1-03=0) | No-Load Brake (A1-03=2) |
| C1: Quick Stop/Reverse Plug Simulation | Yes | Yes |
| C2: Micro Positioning | Yes | Yes |
| C3: End of Travel Limits | Yes | Yes |
| C4: Zero Servo | Yes | Yes |
| C5: Load Check | No | Yes |
| C6: Ultra Lift | No | Yes |
| C7: Torque Limit | Yes | Yes |
| C8: No-Load Brake Hoist | No | Yes |
| C9: G5IN4 Setup | Yes | Yes |
| C10: Weight Measurement | No | Yes |
| C11: Slack Cable Detection | No | Yes |
| C12: Delay Timers | Yes | No |
| C13: Inching Control | Yes | Yes |

Quick Stop™/Reverse Plug Simulation™

The **Quick Stop Function** provides an automatic Alternate Deceleration at Stop Command.

NOTE: The Quick Stop Deceleration time differs from the normal deceleration time and is applied only when the RUN command is removed.

| Parmtr Code | Display | Function | Range | Initial Value | Access Level |
|-------------|---|---|--------------|---------------|--------------|
| C1-01* | Quick Stop 0/1 0 Disabled 1 Enabled | Determines whether Quick Stop is enabled | | 0 | Adv |
| C1-02 | Quick Stop Time | Deceleration time during Quick Stop function. | 0.0–25.5 sec | 1.0 | Adv |

* Initial value is determined by X-Press Programming (Table 4.1 to 4.12).

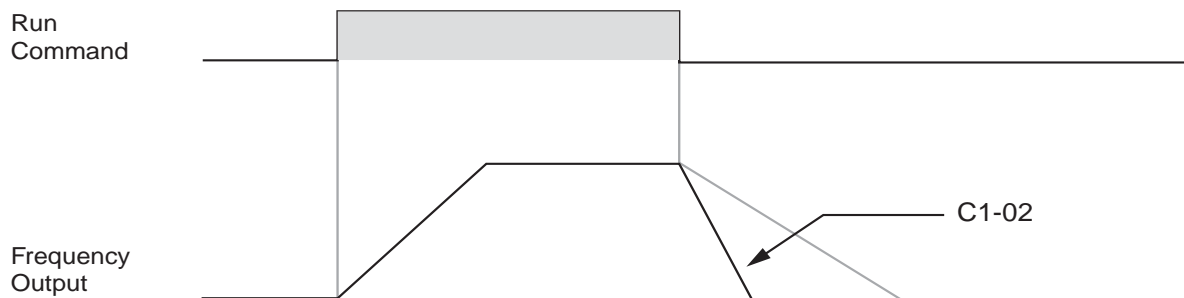

Figure 5-15: Quick Stop

The **Reverse Plug Simulation** provides an automatic alternate deceleration time/acceleration time at a change direction command. The deceleration time and the acceleration time are set independently of the normal acceleration and deceleration times.

| Parmtr Code | Display | Function | Range | Initial Value | Access Level |
|-------------|------------------|--|--------------|---------------|--------------|
| C1-03 | Reverse Plug 0/1 | Determines whether Reverse Plug Simulation is enabled. | | 0 | Adv |
| | 0 Disabled | | | | |
| | 1 Enabled | | | | |
| C1-04 | PlgRev Dec Time | Deceleration time during Reverse Plug Simulation. | 0.0–25.5 sec | 1.0 | Adv |
| C1-05 | PlgRev Acc Time | Acceleration time during Reverse Plug Simulation | 0.0–25.5 sec | 1.0 | Adv |

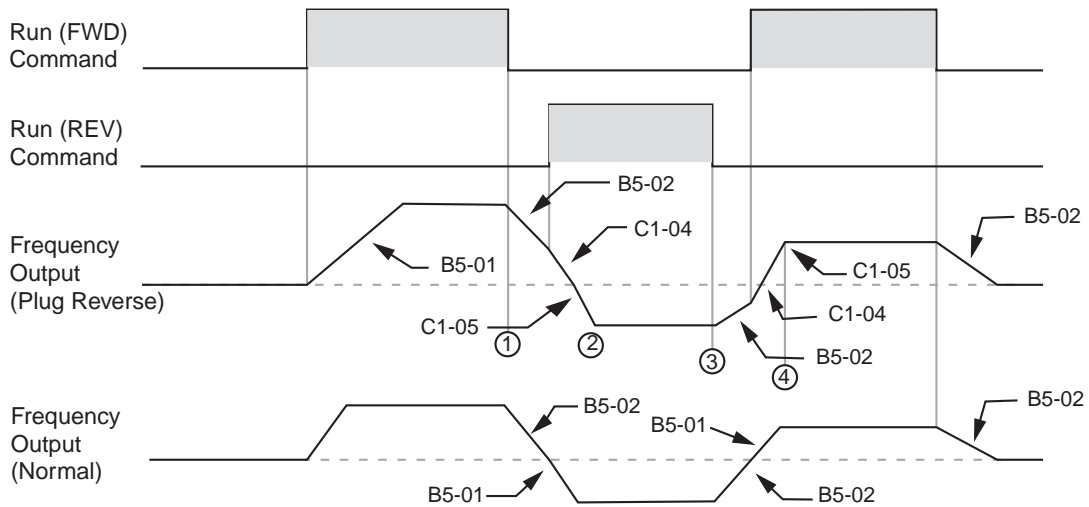

Figure 5-16: Reverse Plug Simulation

Micro-Positioning Control™

Micro-Positioning Control function can provide a reduced speed range operation for precise positioning. Enabled by a Multi-Function Input, it multiplies the normal speed reference by the Micro-Speed Gain. Two Micro-Speed Gains are available. MS Gain 1 (C2-01) and MS Gain 2 (C2-02). They can be adjusted and enabled independently.

| Parmtr Code | Display | Function | Range | Initial Value | Access Level |
|-------------|-----------|--|-----------|---------------|--------------|
| C2-01 | MS Gain 1 | For Micro-Positioning Control—the number multiplied by the Analog or Digital Speed Reference to achieve slow-speed operation. | 0.00–2.55 | 1.00 | Adv |
| C2-02 | MS Gain 2 | For Micro-Positioning Control—an alternate number multiplied by the Analog or Digital Speed Reference to achieve slow-speed operation. | 0.00–2.55 | 1.00 | Adv |

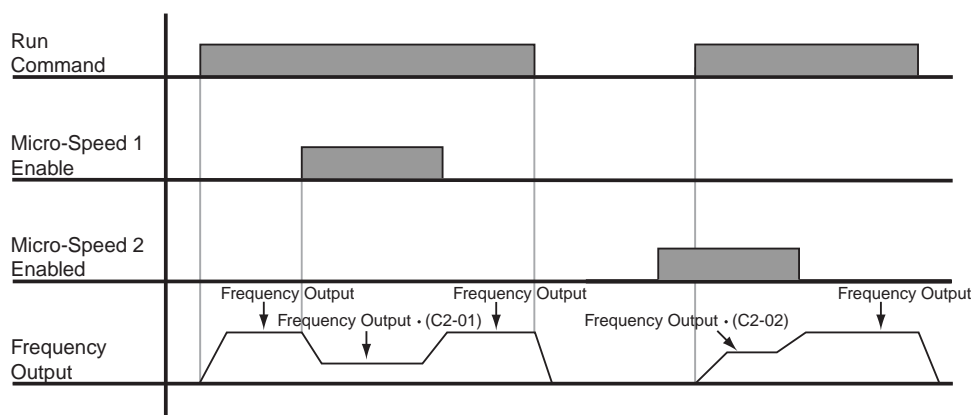

Figure 5-17: Micro-Positioning Control

NOTE: If both Micro-Speed 1 and Micro-Speed 2 are enabled. Micro-Speed 1 always takes higher priority over Micro-Speed 2.

Travel Limits

This function can automatically slow and stop a crane or hoist when it reaches the MS travel limits. Two types of limit inputs (slowdown and stop) are available in both travel directions. Inputs can be programmed through either G5IF and G5IN4 cards.

| Parltr Code | Display | Function | Range | Initial Value | Access Level |
|-------------|-------------------|---|--------------|---------------|--------------|
| C3-01 | Up Limit 1 Speed | Speed at Upper Limit input. | 0–150 Hz | 6 | Adv |
| C3-02 | UL 1 Decel Time | Decel time to Upper Limit Speed. | 0.0–25.5 sec | 1.0 | Adv |
| C3-03 | UL 2 Stop Time | Decel time to STOP when Upper Limit is Input. | 0.0–25.5 sec | 1.0 | Adv |
| C3-04 | Low Limit 1 Speed | Speed at Lower Limit input. | 0–150 Hz | 6 | Adv |
| C3-05 | LL 1 Decel Time | Decel time to Lower Limit Speed | 0.0–25.5 sec | 1.0 | Adv |
| C3-06 | LL 2 Stop Time | Decel time to STOP when Lower Limit is input. | 0.0–25.5 sec | 1.0 | Adv |
| C3-07* | Upper Action | Determine the stop method at Upper Limit 2 and Lower Limit 2 Input. | | 0 | Adv |
| | 0 | Decel to Stop | | | |
| | 1 | BB to Stop | Base Block | | |

* Initial value is determined by X-Press Programming (Table 4.1 to 4.12).

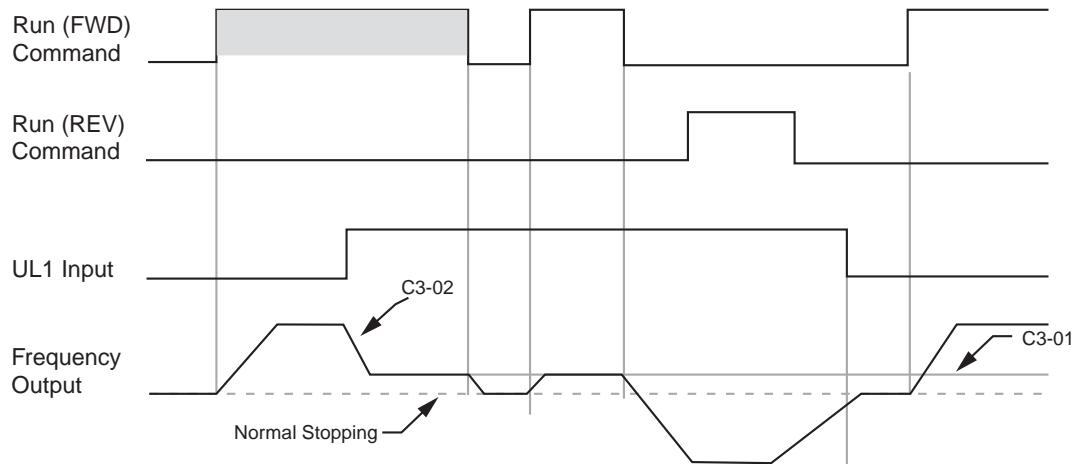

Figure 5-18: Upper Limit (UL1)

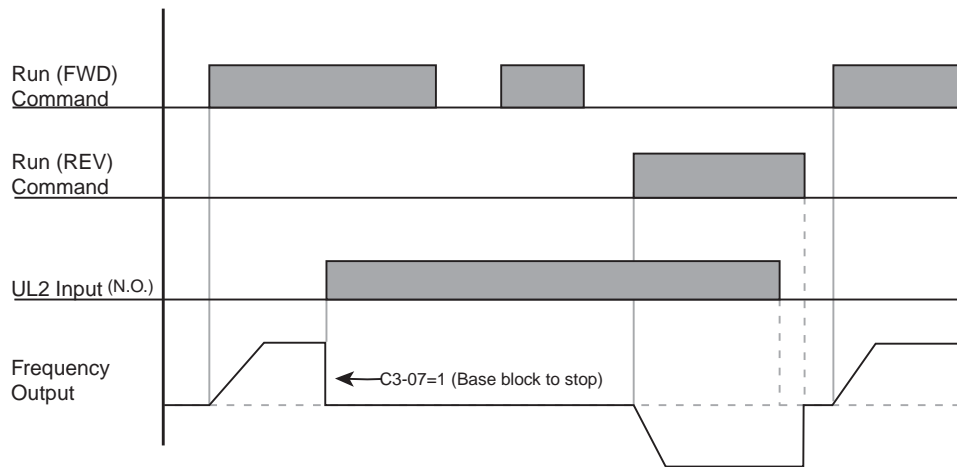

Figure 5-19: Upper Limit 2 (UL2)

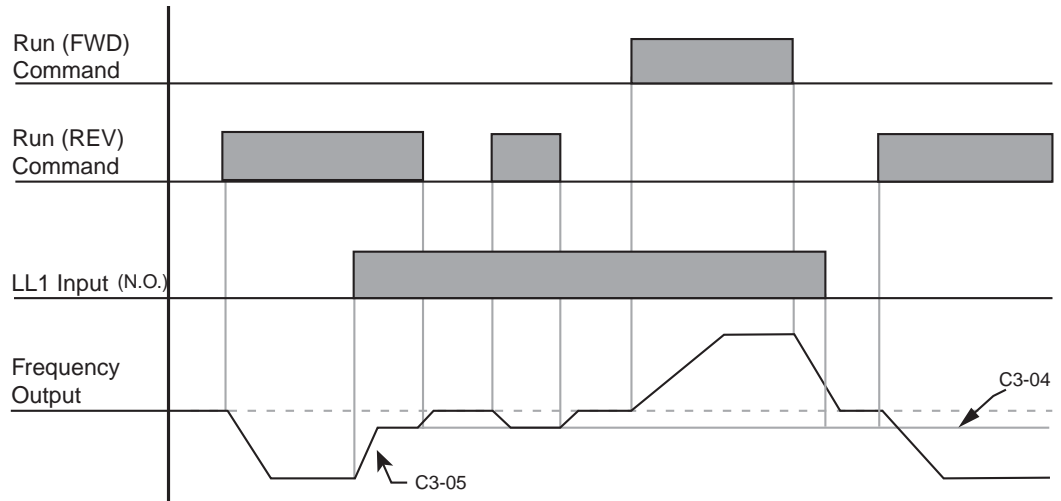

Figure 5-20: Lower Limit 1 (LL1)

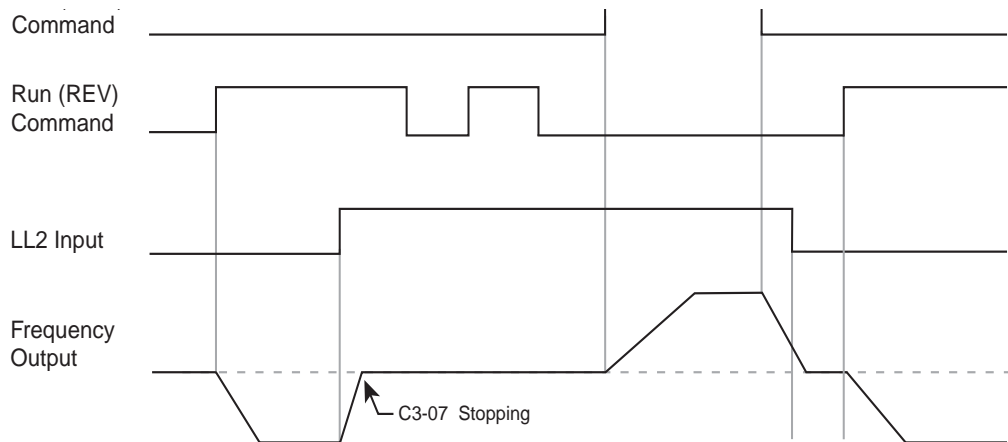

Figure 5-21: Lower Limit 2 (LL2)

Zero Servo

When Zero Servo is enabled, it maintains the motor shaft at a stationary position. This function is enabled by a MFI (Multi-Function Input) that is programmed as the digital input data 3A (H1-01~06=3A). If load float is being used, this time (C4-01) will be added to the standard load float time (C8-10).

| Parmtr Code | Display | Function | Range | Initial Value | Access Level |
|-------------|------------------|--|-----------|---------------|--------------|
| C4-01 | Zero Servo Timer | Maximum duration of Zero Servo action at multi-function input. | 0-255 sec | 10 | Adv |
| C4-02 | Zero Servo Gain | Zero Servo multiplier. | 0-100 | * | Adv |
| C4-03 | Zero Servo Count | Zero Servo completion width. | 0-16383 | 10 | Adv |

* For drive model #s 2006-2080, 4003-4041 and 5003-5032 with software versions 14912.0 - 14912.5, the Initial Value is 25. For drive model #s 2130-2300, 4052-4605 and 5041-5200 the Initial Value is 50.

* For drive model #s 2006-2080, 4003-4041 and 5003-5032 with software versions 14912.6 and greater, the Initial Value is 10. For drive model #s 2130-2300, 4052-4605 and 5041-5200 the Initial Value is 20.

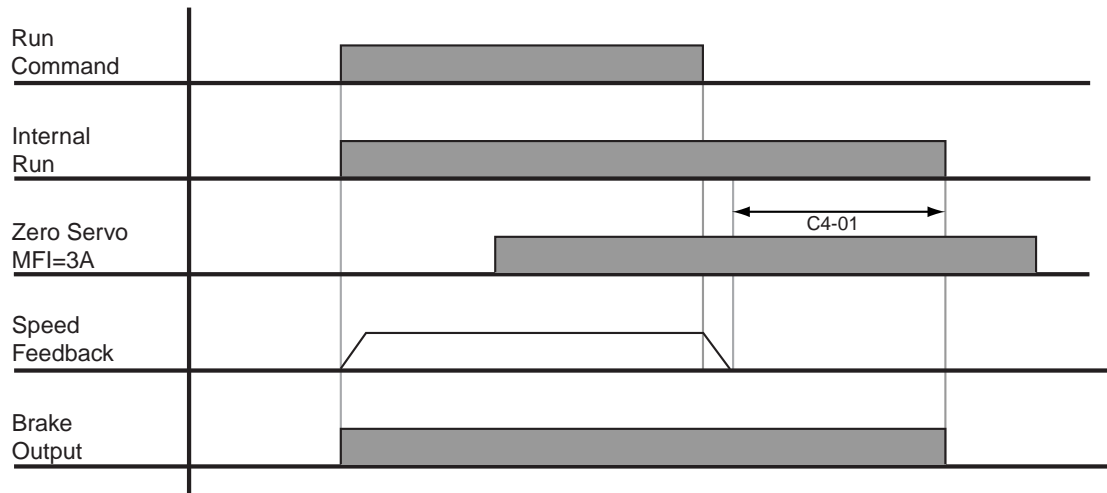

Figure 5-22: Zero Servo

Load Check

Load Check function is a load-limiting feature that ensures the programmed load limit of the hoist is not exceeded. It prevents the lifting (and potential loss) of a load that is overweight. When IMPULSE•VG+ Series 2 detects an overload condition, it prevents any further raising. However, the load can be lowered at the speed that is specified by constant C5-14 (Load Check Fault speeds).

NOTE: Precautions should be taken when using load check where two or more hoists are used to lift a single load.

Example: Use a normally closed relay from the load check output to break the raise (FWD Run) command to the other hoist(s). This will insure that all hoists stop lifting if one hoist is being overloaded.

| Parmtr Code | Display | Function | Range | Initial Value | Access Level |
|-------------|---|---|---------------|---------------|--------------|
| C5-01 | Load Check 0/1 0 Disabled 1 Enabled | Determines whether Load Check is enabled. | | 0 | Adv |
| C5-02 | LC Alarm Action 0 Alarm Only 1 Decel to Stop 2 Coast to Stop 3 Fault Stop | Action at Load Check alarm or fault. NOTE: 14912 software only; if C5-02=1 and B3-03=6, the stopping method will be No Load Brake. | | 1 | Adv |
| C5-03 | Min Torque Ref | Minimum current/torque reference during acceleration that triggers Load Check. | 0–100% | 60 | Adv |
| C5-04 | Look Speed 1 | First Load Check frequency reference. | 0–150 Hz | 6 | Adv |
| C5-06 | Vec Torque Ref | Torque reference at LS1, 2 and 3. | 0–300% | 125 | Adv |
| C5-07 | Look Speed 2 | Second Load Check frequency reference. | 0–150 Hz | 20 | Adv |
| C5-09 | Look Speed 3 | Third Load Check frequency reference. | 0–150 Hz | 60 | Adv |
| C5-11 | I Ref for > LS 3 | Load Check Current when Output Frequency > Look Speed 3. | 30–200% | 160 | Adv |
| C5-12 | LC Setting Time | Time for holding Output Frequency to stabilize Output Current. | 0.00–2.55 sec | 0.20 | Adv |
| C5-13 | LC Test Time | Time (after the LC Setting Time) for comparing Output Current with Reference Current | 0.00–2.55 sec | 0.10 | Adv |
| C5-14 | LC Fault Speed | Maximum lowering speed after Load Check fault | 0–150 Hz | 6 | Adv |

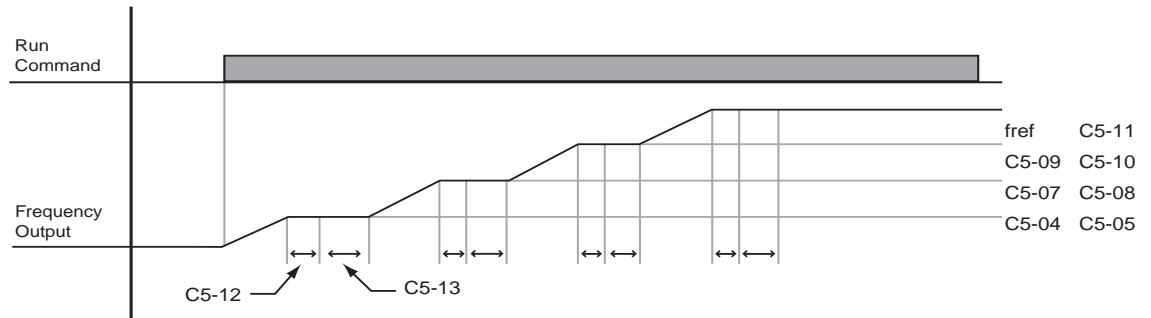

Figure 5-23: Load Check

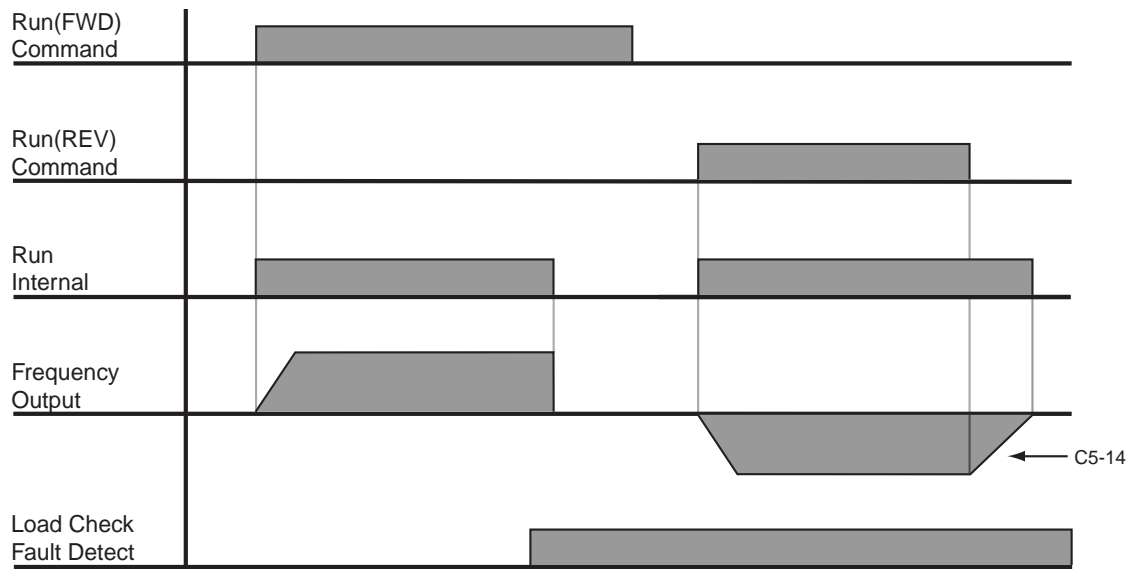

Figure 5-24: Example of Operation C5-02=2

Ultra-Lift

Ultra-Lift provides additional productivity by allowing a crane or hoist to quickly move into position. The feature enables the motor to over speed when the load is less than 100 percent of the rated capacity. Ultra-Lift determines the torque required for the load, calculates the maximum safe speed, and automatically accelerates to this speed. However, the maximum speed cannot exceed the lesser value of the Ultra-Lift Maximum Output Frequency-RAISE (C6-02), Ultra-Lift Maximum Output Frequency-LOWER (C6-03), and Maximum Frequency (E1-04).

NOTE: Note: Ultra-Lift is disabled when in traverse applications. Maximum Frequency (E1-04) must be \geq C6-02 and C6-03.

| Parmtr Code | Display | Function | Range | Initial Value | V/F Access | Open Loop Vector Access |
|--------------------|---|--|--------------|----------------------|-------------------|--------------------------------|
| C6-01 | Ultra Lift 0/1 0 Disabled 1 Enabled Automatic 2 Enabled by MFI | Determines whether Ultra Lift is enabled. | | 0 | Adv | Adv |
| C6-02 | Ultra Lift ForSpd | Maximum Output Frequency during Ultra Lift—FORWARD. | 0–150 Hz | 60 | Adv | Adv |
| C6-03 | Ultra Lift RevSpd | Maximum Output Frequency during Ultra Lift—REVERSE. | 0–150 Hz | 60 | Adv | Adv |
| C6-04 | Ultra Lift For T | Maximum output torque below which Ultra Lift—FORWARD is enabled. | 0–100% | 50 | Adv | Adv |
| C6-05 | Ultra Lift Rev T | Maximum output torque below which Ultra Lift REVERSE is enabled. | 0–255% | 30 | Adv | Adv |
| C6-06 | UL Enabling Spd | Threshold frequency at which Ultra Lift is enabled. | 0–150 Hz | 60 | Adv | Adv |
| C6-07 | UL Delay Time | Delay time at enabling speed prior to torque-compare function. | 0.0–30.0 sec | 2.0 | Adv | Adv |
| C6-08 | SFS Acc Gain | Speed feedback acceleration multiplier. | 0.1–9.9 | 1.0 | Adv | Adv |

Enable Ultra-Lift Function:

2,3,5-Speed Multi-Step (A1-04=0, 5, or 6):

1. Set C6-01=1 or 2 to enable the **Ultra-Lift Function**, 1= Enable Automatic, 2= Enable by Multi-Function Input (MFI).
2. Set C6-02 and C6-03 to determine **Ultra-Lift** maximum FWD/REV output frequency.
3. Set C6-04 and C6-05 to determine **Ultra-Lift** maximum enable output current.
4. Set the **Ultra-Lift Enabling Speed (C6-06)** one or two hertz below the maximum normal running speed reference.

For example: If the maximum normal running speed is at 60 Hz, set C6-06 to 59 Hz or 58 Hz as the **Ultra-Lift Enabling Speed**.

5. Ensure that the **Maximum Frequency (E1-04)** is increased from 60 Hz.

2, 3 Step Infinitely Variable (A1-04=1 or 2)

6. If the system is using **2-Step** or **3-Step Infinitely Variable** as the **Speed Control Method**, the following formula is used to adjust the constant **B2-01 (Reference Upper Limit)**.

$$B2-01=60 \text{ Hz} \times 100 / E1-04$$

Bi-Polar/Uni-Polar Analog (A1-04=3 or 4)

7. If the system is using **Bi-Polar Analog** or **Uni-Polar Analog** as the **Speed Control Method**, the following formula is used to adjust the constant **H3-02 (Gain Multiplier for Terminal 13 analog input signal)**. **H3-10 (Gain Multiplier for Terminal 14 analog input signal)**.

$$H3-02=60 \text{ Hz} \times 100 / E1-04 \text{ or } H3-10=60 \text{ Hz} \times 100/E1-04$$



WARNING

Motors and drive machinery must be capable of operating above motor base speed. Consult the motor/gearbox/hoist manufacturer before enabling Ultra Lift function. Failure to observe this warning may result in damage to equipment and possible injury or death to personnel.

Torque Limit

IMPULSE•VG+ Series 2 dynamically controls the torque output of the motor at all times. The Torque Limit Function limits the amount of motor torque on all four quadrants of vector control operation:

- Forward Motoring
- Reverse Motoring
- Forward Regenerating
- Reverse Regenerating

| Parmtr Code | Display | Function | Range | Initial Value | Access Level |
|-------------|--------------------|--|--------|---------------|--------------|
| C7-01 | Torque Limit Fwd | FORWARD torque limit | 0–300% | 150 | Adv |
| C7-02 | Torque Limit Rev | REVERSE torque limit | 0–300% | 150 | Adv |
| C7-03 | Torq Lmt Rgn | Regenerative torque limit at FORWARD | 0–300% | 180 | Adv |
| C7-04 | Torq Limit Rev Rgn | Regenerative torque limit at REVERSE | 0–300% | 180 | Adv |
| C7-07 | T-Lim Gain MFI | Used when H1-01~H1-06 = 15 and MFI is on | 0–2.55 | 1.25 | Adv |

No-Load Brake Start/Stop

The No-Load Brake Hoist mode provides a special start/stop sequence designed specifically for No-Load Brake Hoists. This mode is enabled automatically when the Motion is set to NLB Hoist (A1-03=2). This will also automatically set the Stopping Method to No-Load Brake (B3-03 = 6).

The NLB Sequence is comprised of a series of Timers and Counters that monitor certain feedback devices. The sequence is divided into two parts, NLB Start and NLB Stop.

The NLB Start Sequence begins by building up torque in the motor to a predefined level within the C8-01 (Torque Compensation Time) timer. This level is determined by several factors which are defined below. During the C8-01 time, the drive is monitoring current to motor. The internal current feedback equation must be satisfied within the time set in C8-02 (IFB OK Time). If it is not, a BE2 (No-Current) alarm will be displayed on the keypad and the drive will stop outputting voltage to the motor. The brake will remain closed.

Factor 1: On the first run command after power up, or after any major fault which causes the NLB Stop sequence to be skipped, the NLB Start sequence by default looks at the value programmed in C8-16, the Initial Brake Release torque.

Factor 2: Once the system has completed a successful NLB Start and NLB Stop, a new value is used. This value is one that has been memorized and stored into memory during the NLB Stop Sequence. It is equivalent to the amount of torque required for the motor to hold the load that is on the hook in Zero Servo (otherwise known as Load Float) with the brake released. Some benefits of memorized Load Float torque for the next brake release are:

- Faster response to run commands when drive is in Base Block Status.
- Upon brake release, shaft rotation begins in the direction of the run command.

If the memorized value is less than the programmed value in C8-03 (Minimum Brake Release torque), then C8-03 is used as the next brake release value. If the feature must be disabled, C8-03 will override C8-16 if it is a greater value than C8-16.

Once the brake has been commanded to release, the output remains in Zero Servo for the amount of time programmed into C8-04. During C8-04, the drive waits for the brake to completely open and watches encoder feedback. If the amount of feedback is less than the setting in C8-05 (Roll Back Count), then the drive proceeds to the BE3 check. If it is not, a BE1 alarm is displayed on the keypad and the sequence stops. For the BE3 check, if the brake opened mechanically, then the encoder feedback must be greater than or equal to the value programmed in C8-07 (BE3 Detect Count) within the time set in C8-06 (BE3/Alternate Torque Time). If it is not, then BE3 is displayed. By the time the drive has completed the BE3 check, there should be a significant amount of motor shaft movement and the NLB start sequence is complete.

The NLB Stop Sequence begins when the run command has been removed and the output frequency has decelerated to zero. Once at zero speed, the motor maintains a Zero Servo position or more commonly referred to as Load Float for the duration of C8-10 (Load Float Time). During the Load Float time, run commands in either direction are accepted and will begin accelerating immediately in the commanded direction thereby skipping the NLB Start Sequence entirely. The Load Float Timer is reset after each new run command. Once the Load Float Timer expires, the brake output command is removed (thereby closing the brake) and Zero Servo is maintained for the time set in C8-11 (Brake Delay Time) to allow the brake to fully close. Once the Brake Delay Time has expired, the BE6 check is executed. The BE6 check monitors encoder feedback and compares it to C8-13 (BE6 Max count). The encoder feedback must not exceed the number of counts in C8-13 within the C8-12 (BE6 Detect Timer) time. If it does (meaning the load slipped through the brake), a BE6 alarm is displayed on the keypad and the drive will reset its zero servo position and maintain its new position. Run commands will still be accepted with the exception of a reduced speed in the up direction set by C8-17 (BE6 Up speed) and the NLB stop sequence will begin again once the run command had been removed.

NOTE: All brake faults are annunciated by both the keypad, and via a programmed digital output. Since the keypad is not visible by the operator, an external warning device must be used to ensure proper safety of personnel and equipment. Annunciating a brake fault can be accomplished by using one, or both, of the following methods. 1) An indicating or strobe light that is continuously “ON”, indicating proper operation. If the light should turn “OFF”, this indicates that the light bulb has either burned out, or there is a drive or brake problem. Either scenario requires immediate corrective action. The use of an indicating light will require an additional relay, with a N/C contact, wired to the G5OUT Card 2) An audible warning device that will sound during a brake fault condition. A 120 VAC audible warning device can be wired directly to the G5OUT Card, provided that it’s ratings do not exceed the 1 Amp, 120 VAC, Inductive rating of the G5OUT Card.

If a brake fault is annunciated during a “Start” sequence, it is recommended that the crane be moved to a safe location with the load on the hook. The hoist should only be operated if absolutely necessary. In this type of alarm sequence, either the brake is seized or the drive cannot develop enough torque in the motor in the time allotted. To troubleshoot the hoist it will be necessary to monitor the keypad on the drive and operate the hoist at the same time. Two people are recommended for this procedure. With one person operating the hoist and the other person monitoring the keypad, run the hoist. The keypad should display one of the following alarms: BE1, BE2, BE3, BE4. For corrective action, refer to “Troubleshooting the Drive” in Chapter 6 of this manual.

If a brake fault is annunciated after the hoist has come to a complete stop, and Load Float (C8-10) has timed out, it would indicate that the drive has checked the brake and determined that the brake has insufficient torque available to hold the load, **DO NOT TURN OFF POWER**. This condition indicates that the brake has failed and the drive / motor combination is suspending the load. If, during this condition, the hoist is operated in the “Raise” direction, it will only be allowed to run at a speed equal to or less than the “BE6 Up Speed” setting in parameter C8-17 (C8-17 is 6Hz by default.) This is an additional indication that the brake has failed open, or the load is slipping through the brake. It is recommended that the crane be moved to a safe location and the load lowered to the ground. Corrective action should be taken to repair the brake. The keypad will be displaying one of two alarms during this condition: BE5 or BE6. Refer to “Troubleshooting the Drive” in Chapter 6 of this manual.



WARNING

DO NOT turn off power to the drive during a BE6 alarm. This may result in loss of control of the load if the brake has failed in the open position or is unable to hold the load.

To enable BE6 detection, C8-12 must be greater than 0. For more information on BE6 detection, reference Fig. 5-30, No Load Brake BE6 timing diagram.

| Parmtr Code | Display | Function | Range | Initial Value | Access Level |
|-------------|-----------------|---|----------------|---------------|--------------|
| C8-01 | Torq Comp Time | Time for torque to build to 300% at start. | 0.00–2.55 sec | * | Adv |
| C8-02 | IFB OK Timer | Sets the amount of time to look for the current feedback to be OK before posting a BE2 alarm. Setting this parameter to 0 (Zero) will disable torque proving at start & eliminate BE2 detection (Not recommended). | 0.00–2.55 sec | * | Adv |
| C8-03 | Brake Rel Torq | Minimum brake release torque. | 0–300% | 10 | Adv |
| C8-04 | Roll Back Timer | Sets the amount of time for the brake to release and for brake feedback to be received into the Brake Answer Back Multi-Function input at start before posting BE4 alarm. It is also the time period during which the amount of roll back is checked. | 0.00–2.55 sec | 0.70 | Adv |
| C8-05 | Roll Back Count | Detection counts for excessive roll back. | 0–16536 pulses | 400 | Adv |
| C8-06 | BE3/Alt Torq T | Time period during which C8-07 is measured. Also see C8-08. | 0.00–2.55 sec | 0.50 | Adv |
| C8-07 | BE3 Det Count | Detection count for Encoder/ Seized-Brake Fault (BE3). It is the minimum encoder pulse count, during the time period of C8-06, below which the BE3 alarm is triggered. | 0–16536 pulses | 50 | Adv |

| Parmtr Code | Display | Function | Range | Initial Value | Access Level |
|---|-------------------|---|----------------|----------------------|---------------------|
| C8-08 | Alt Rev T Limit | For a LOWER command in the NLB Hoist Motion Mode only—Torque limit for time of C8-06 to prevent driving through a brake that has failed closed with a load on the hook. | 0–100% | 10 | Adv |
| C8-09 | Zero Speed Level | Determines speed feedback at which Load Float activates. | 0–150 Hz | 1 | Adv |
| C8-10 | Load Float Time | After stop command time period during which the load is held at the zero-position and the electric brake is not set. | 0-255 sec | 10 | Adv |
| C8-11 | Brake Delay Time | Sets the amount of time for the brake to set and for brake feedback to be removed from the Brake Answer Back Multi-Function input at stop before posting a BE5 Alarm. | 0.0–25.5 sec | 0.7 | Adv |
| C8-12 | BE6 Detect Timer | Time period during which the electric brake is set and tested for sustaining the load. NOTE: To disable BE6 detection, set C8-12 to 0.0. | 0.0–25.5 sec | 5.0 | Adv |
| C8-13 | BE6 Max Count | Total pulse counts must be less than C8-13, during C8-12, otherwise BE6 alarm. | 0–16536 pulses | 250 | Adv |
| C8-15 | Load Float Ext. T | Load Float extension time enabled by MFI=46. | 0–255sec | 10 | Adv |
| C8-16 | Init Brk Release | Brake release torque at power up and after UL2, LL2, EF faults or MFI's which cause the output to base block. | 0-300% | 100 | Adv |
| C8-17 | BE6 Up Speed | Maximum up speed after BE6 is detected. | 0.00–150.00 Hz | 6.00 | Adv |
| * For drive model #s 2006-2080, 4003-4041 and 5003-5032 with software versions 14912.0 - 14912.5, the Initial Value is 1.5. For drive model #s 2130-2300, 4052-4605 and 5041-5200 the Initial Value is 2.5. | | | | | |
| * For drive model #s 2006-2080, 4003-4041 and 5003-5032 with software versions 14912.6 and greater, the Initial Value is 1.0. For drive model #s 2130-2300, 4052-4605 and 5041-5200 the Initial Value is 1.5. | | | | | |

Load Float PG Monitor

This parameter is used to enable encoder monitoring during Load Float. When it is disabled, Load Float will function using the same timers, but with no shaft movement or encoder monitoring.

NOTE: When C8-18 is disabled, parameter settings for C8-19–C8-21 have no effect on any other function.

| Parmtr Code | Display | Function | Range | Initial Value | Access Level |
|--------------------|--------------------|---|--------------|----------------------|---------------------|
| C8-18 | Load Float PG Moni | Enables encoder monitoring during Load Float. | 0 to 1 | <i>Disabled</i> | Adv |
| | 0 | <i>Disabled</i> | | | |
| | 1 | <i>Enabled</i> | | | |

PG Monitor Count

Parameter C8-19 is used to set the desired movement length in terms of motor shaft rotation. The counts are encoder pulses converted to a number. One motor revolution = F1-01 (PG Pulse/Rev) *4 (quadrature). For example, if F1-01=1024, then $1024*4=4096=1$ revolution. See Figure below.

| Parmr Code | Display | Function | Range | Initial Value | Access Level |
|------------|---------------|--|-------------|---------------|--------------|
| C8-19 | PG Moni Count | Sets the desired movement length in terms of motor shaft rotation. | 0 to 99 PPR | 20 | Adv |

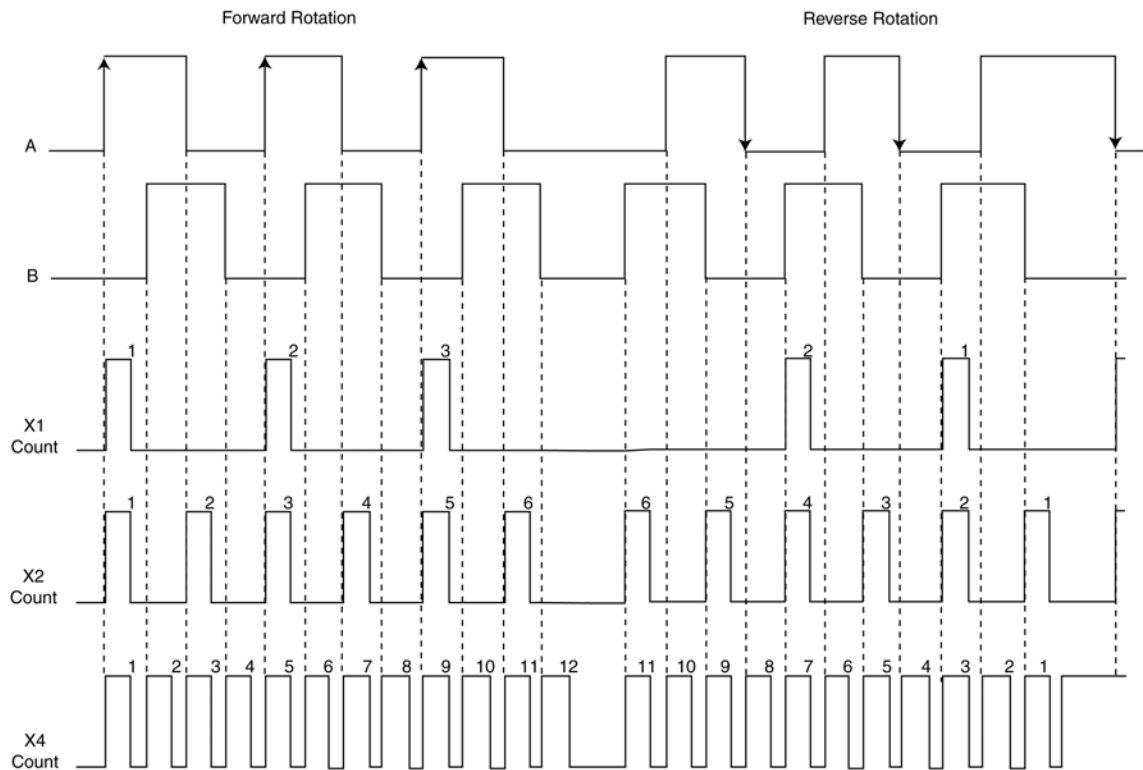

Figure 5-25: PG Monitor Count

For this function, 1 motor revolution would be undesirable so the range of the parameter setting has been limited. The motor shaft will rotate forward for the C8-19 counts and then rotate back to its start position and repeat for the duration of the Load Float Time (C8-10). The speed reference at which the drive commands the motor shaft to move at is partly derived by the distance at which it needs to travel. Increasing the distance, increases the frequency reference.

Shaft Oscillation Gain

This parameter will adjust the frequency at which the oscillations occur. As the gain increases, the output frequency increases and the motor will oscillate faster.

| Parmtr Code | Display | Function | Range | Initial Value | Access Level |
|--------------------|------------------|---|--------------|----------------------|---------------------|
| C8-20 | Shaft Osc. Gain | Adjusts the frequency which the oscillations occur. | 0 to 60 | 15 | Adv |
| C8-21 | PG Moni Flt Time | Sets the amount of time allowed for the oscillation to occur without a fault. | 0.00 to 8.00 | 1.00 | Adv |

PG Monitor Fault Time

This parameter sets the amount of time allowed for the oscillation to occur without a fault. E.g. If the motor shaft is told to move forward 15 pulses at a calculated frequency, the drive expects to see 15 counts forward in C8-21 time or less. If it does not, the drive sets a PGO2 fault indicating a problem with the PG circuit.

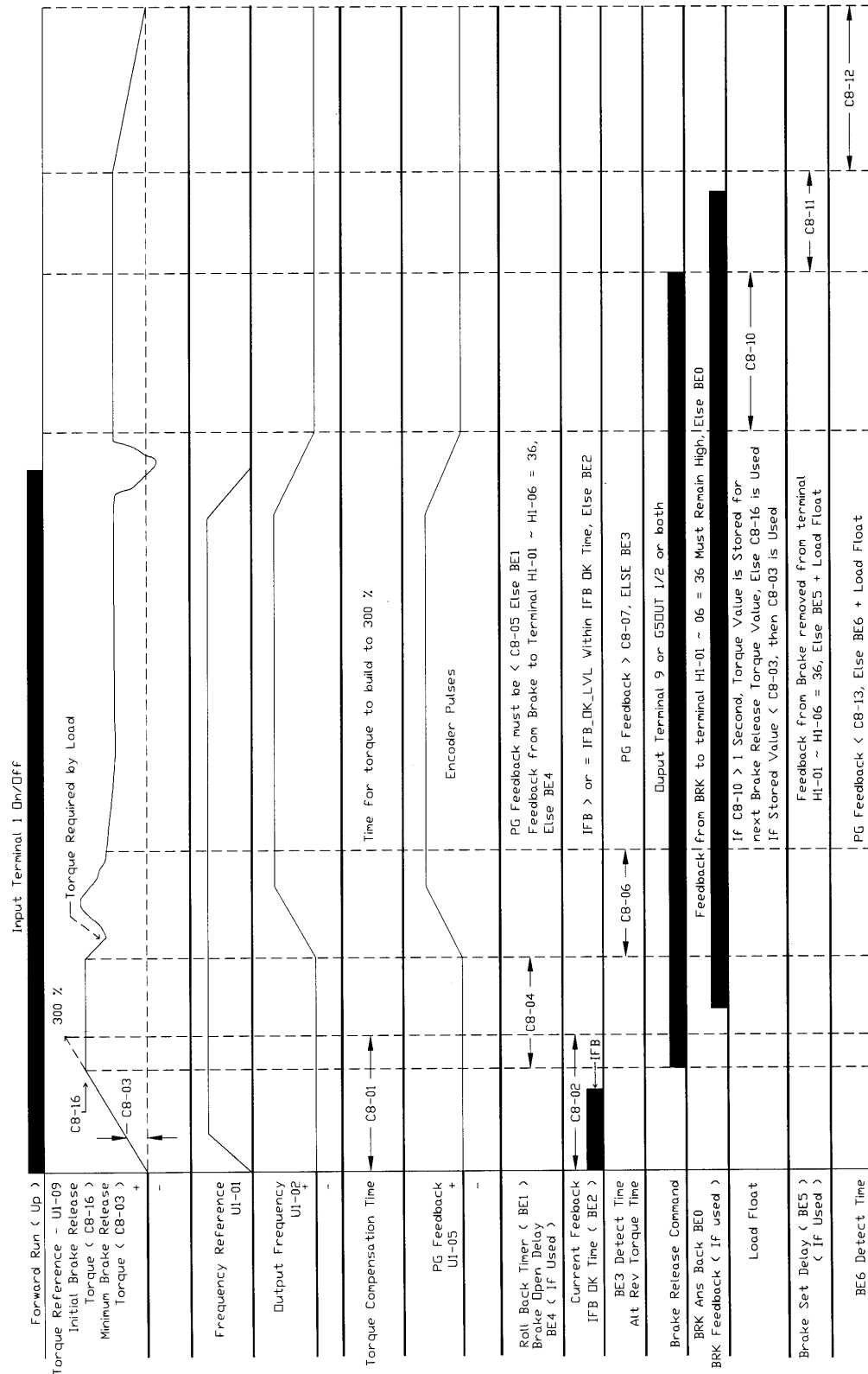

Figure 5-26: No Load Brake Up Timing Diagram
Applies to software versions 14908, 14909, 14911 and 14912

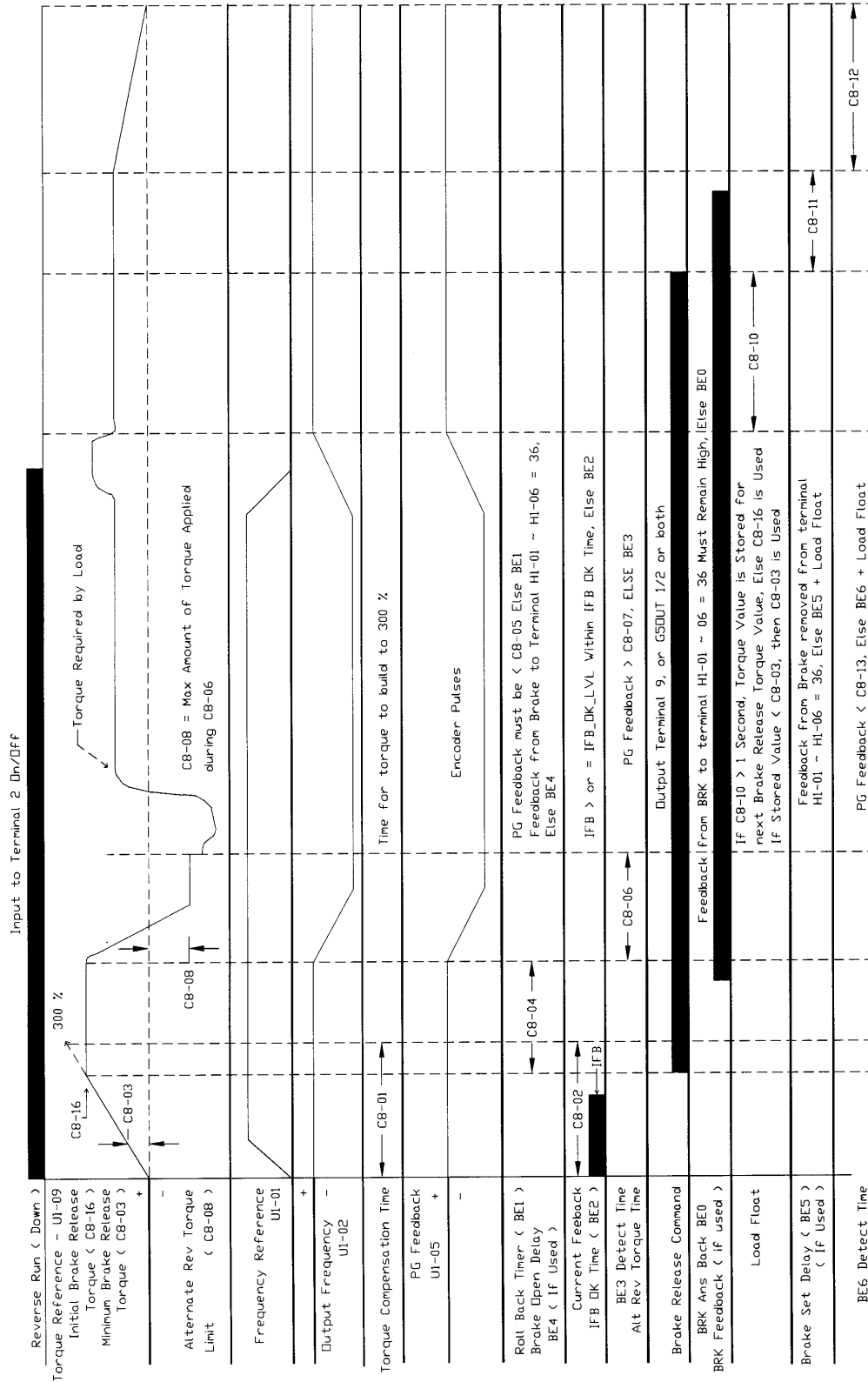

Figure 5-27: No Load Brake Down Timing Diagram
Applies to software versions 14908, 14909, 14911 and 14912

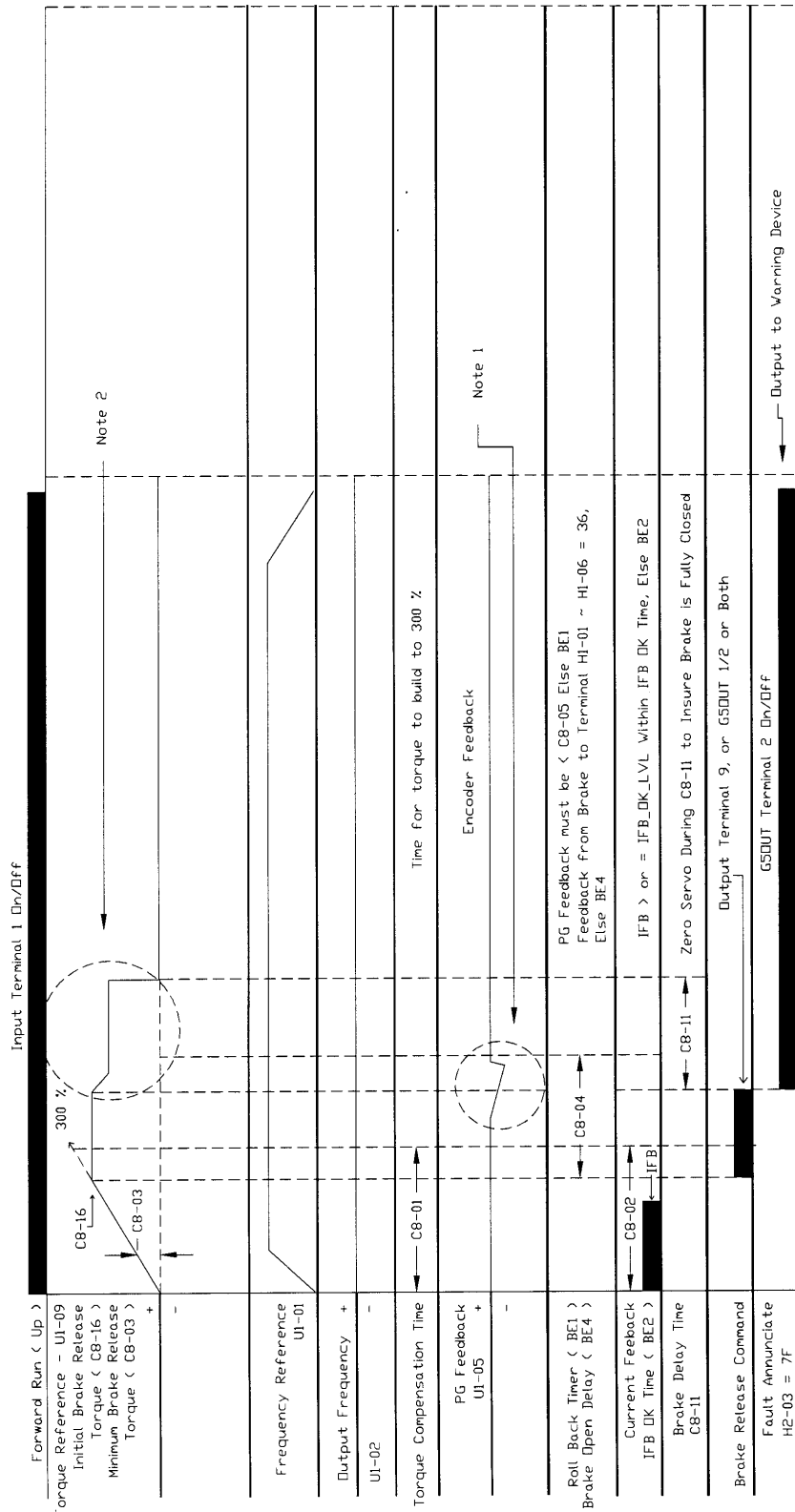
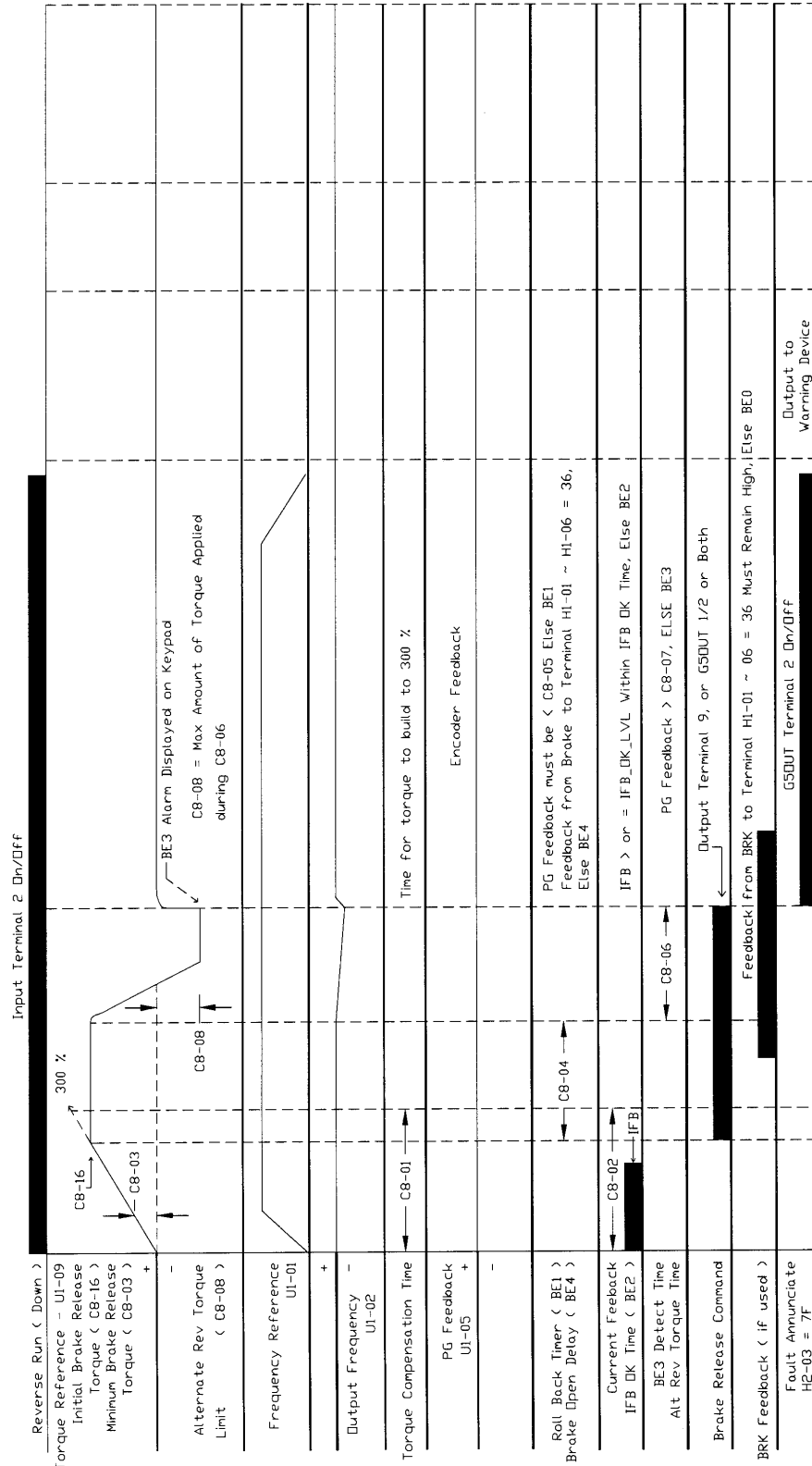

Figure 5-28: No Load Brake BE1 Timing Diagram
Applies to software versions 14908, 14909, 14911 and 14912

Notes:

1. Rollback is detected. PG Feedback is > CB-05. BE1 Alarm is displayed on Keypad until Run Command is removed, Then Reset.
2. When BE1 is detected, Zero Servo is Maintained During CB-11 Time to Insure Brake is Fully Closed.



Notes:

1. If Brake Feedback is used it should appear as drawn. If it does not, then BE4 is Display on Keypad.
2. If Brake Feedback is used it should appear as drawn. If it does but the PG Feedback is < C8-07 within C8-06 time, then BE3 is Displayed on Keypad.
3. If No Brake Feedback is used, and PG Feedback is < C8-07 within C8-06 time, then BE3 is Displayed on Keypad.

Figure 5-29: No Load Brake BE3 Timing Diagram
Applies to software versions 14908, 14909, 14911 and 14912

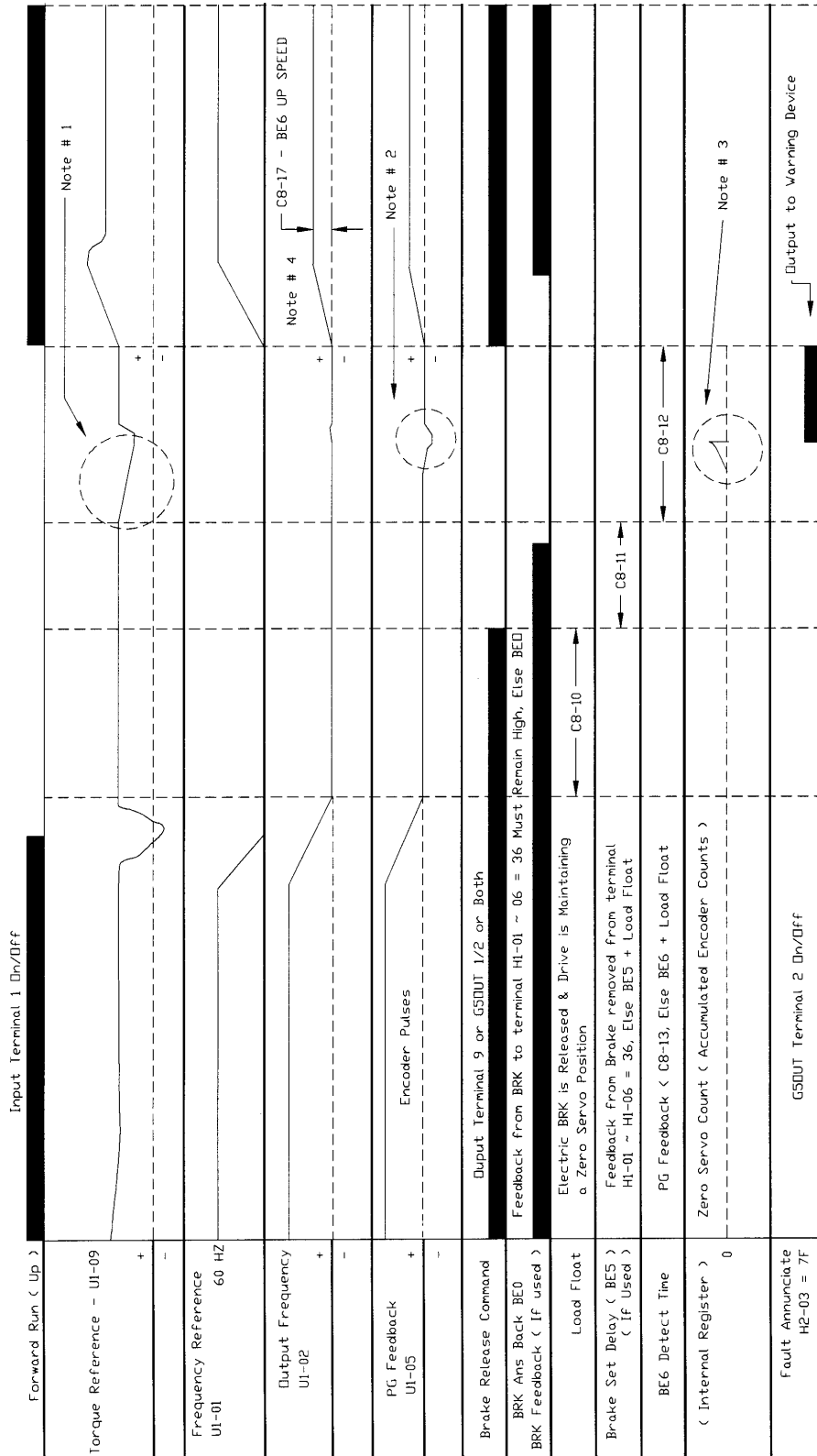

Notes:

1. Torque Slowly Decays During C8-12 To Check For Movement Through Electric Parking Brake.
2. Motor Shaft Movement Detected By Encoder Pulses.
3. Encoder Counts Are Stored And Compared To C8-13. If The Accumulated Counts are > than C8-13, Then A BE6 Alarm is Displayed On the Keypad + Drive Floats The Load.
4. After A BE6 is Detected, Up Speed is Limited to C8-17 until a Stop Sequence Is Successfully Completed.

Figure 5-30: No Load Brake BE6 Timing Diagram
Applies to software versions 14908, 14909, 14911 and 14912

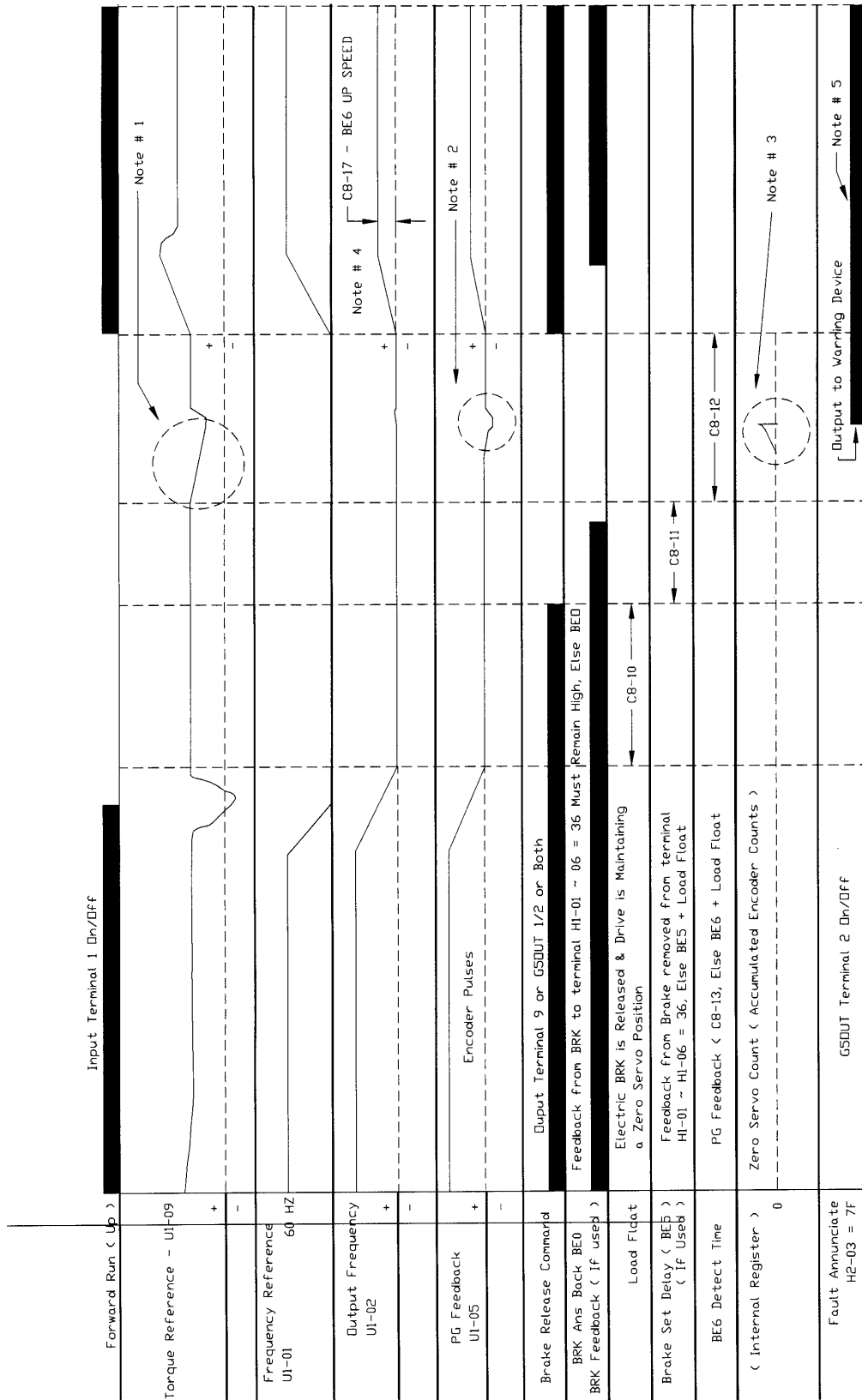

Figure 5-31: No Load Brake BE6 Timing Diagram
Applies to software versions 14910 and 14911 and 14912

No-Load Brake Sequence Faults

Table 5.2

| Fault Code | Fault or Indicator Name/Description |
|-------------------|--|
| BE0 | Brake Answer-Back Fault. During RUN, Brake Answer-Back is lost. Input from brake contactor or brake limit switch has been disconnected for more than 500 msec. |
| BE1 | Torque-Proving Fault. At START, pulse feedback, after brake release, is greater than C8-05 count. There is excessive roll-back at start. |
| BE2 | Current-Proving Fault. At START for Torque Proving Sequence only-Current IFB has not reached predetermined setting within C8-02 time at START. |
| BE3 | Brake Release Fault. For Brake Release-Check Sequence only-Pulse feedback is less than C8-07 counts. After electric brake release command is output-Electric brake is not released. |
| BE4 | Brake Answer-Back Fault. At Start, Brake Answer-back is not input within C8-04 time. |
| BE5 | Brake Answer-Back Fault. At Stop, Brake Answer-back signal is not removed within C8-11 time. |
| BE6 | Brake Set Fault. At Stop, Brake Proving Sequence only-Pulse feedback after brake command removed, is greater than C8-13 count-Excessive movement through brake at stop. |
| BE7 | Brake Answer-Back Fault. At Power Up, Brake Answer-back is on-Electric brake not closed. |

Optional Digital Input Set-up (G5IN4 Digital Multi-Function Inputs)

| Parmtr Code | Display | Function | Range | Initial Value | Access Level |
|-------------|-------------|---|-----------|---------------|--------------|
| C9-01 | G5IN4 0/1 | Determines whether the G5IN4 Digital Multi-Function Inputs are enabled. | | 0 | Adv |
| | 0 Disabled | | | | |
| | 1 Enabled | | | | |
| C9-02 | G5IN4 Setup | Determines the four settings for G5IN4 Digital Multi-Function Inputs. | 0000–FFFF | 0 | Adv |

The optional G5IN4 board accepts four additional multi-function inputs. The G5IN4 board has four terminals, each of which can be programmed to one of the fourteen sets of inputs. Each input in the set can be enabled or disabled.

1. Set C9-01 to 1.
2. Determine the parameter C9-02 setting by specifying the first digit (from left) and the fourth digit (from left) using tables 5.4 and 5.5. The second and third digit should always be “0”.
3. Set parameter C9-02.

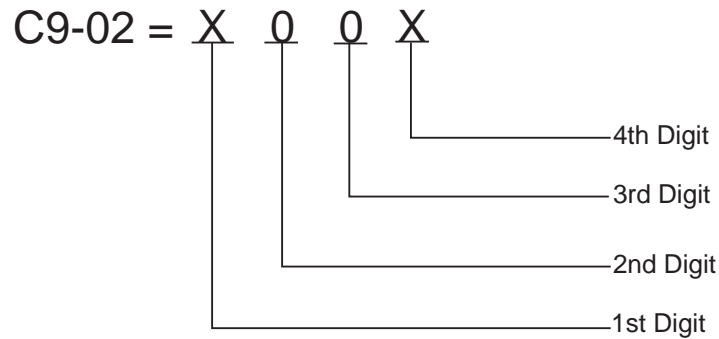

Table 5.3

1 = 120V is present on terminal
 0 = No voltage is present on terminal

| MONITOR | TERMINAL | | | |
|---------|----------|---|---|---|
| UI-25 | 1 | 2 | 3 | 4 |
| 1 | 1 | 0 | 0 | 0 |
| 2 | 0 | 1 | 0 | 0 |
| 3 | 1 | 1 | 0 | 0 |
| 4 | 0 | 0 | 1 | 0 |
| 5 | 1 | 0 | 1 | 0 |
| 6 | 0 | 1 | 1 | 0 |

| MONITOR | | TERMINAL | | | |
|---------|---|----------|---|---|---|
| 7 | 1 | 1 | 1 | 1 | 0 |
| 8 | 0 | 0 | 0 | 0 | 1 |
| 9 | 1 | 0 | 0 | 0 | 1 |
| A | 0 | 1 | 0 | 0 | 1 |
| B | 1 | 1 | 0 | 0 | 1 |
| C | 0 | 0 | 0 | 1 | 1 |
| D | 1 | 0 | 0 | 1 | 1 |
| E | 0 | 1 | 1 | 1 | 1 |
| F | 1 | 1 | 1 | 1 | 1 |

Table 5.4: G5IN4 Digital Multi-Function Input Sets (1 through E) (Software 14906, 14908, 14909)

| First Digit (From Left) You Enter | Multi-Function Input Assigned to Each Terminal | | | |
|-----------------------------------|--|---|---|---|
| | Terminal 1 | Terminal 2 | Terminal 3 | Terminal 4 |
| 1 | <i>Upper Limit—SLOW DOWN; Normally Closed</i> | <i>Upper Limit STOP; Normally Closed</i> | <i>Lower Limit SLOW; Normally Closed</i> | <i>Lower Limit STOP; Normally Closed</i> |
| 2 | <i>Upper Limit—SLOW DOWN; Normally Open</i> | <i>Upper Limit STOP; Normally Open</i> | <i>Lower Limit SLOW; Normally Open</i> | <i>Lower Limit STOP; Normally Open</i> |
| 3 | <i>Upper Limit STOP; Normally Closed</i> | <i>Lower Limit STOP; Normally Closed</i> | <i>Micro-Positioning Control Multiplier 1</i> | <i>Micro-Positioning Control Multiplier 2</i> |
| 4 | <i>Upper Limit STOP; Normally Open</i> | <i>Lower Limit STOP; Normally Open</i> | <i>Micro-Positioning Control Multiplier 1</i> | <i>Micro-Positioning Control Multiplier 2</i> |
| 5 | <i>Upper Limit STOP; Normally Closed</i> | <i>Lower Limit STOP; Normally Closed</i> | <i>Micro-Positioning Control Multiplier 1</i> | <i>Swift-Lift Enable</i> |
| 6 | <i>Upper Limit STOP; Normally Open</i> | <i>Lower Limit STOP; Normally Open</i> | <i>Micro-Positioning Control Multiplier 1</i> | <i>Swift-Lift Enable</i> |
| 7 | <i>Upper Limit STOP; Normally Closed</i> | <i>Lower Limit STOP; Normally Closed</i> | <i>Micro-Positioning Control Multiplier 1</i> | <i>Torque Limit Acceleration/Deceleration</i> |
| 8 | <i>Upper Limit STOP; Normally Closed</i> | <i>Lower Limit STOP; Normally Closed</i> | <i>Micro-Positioning Control Multiplier 1</i> | <i>Torque Limit Acceleration/Deceleration</i> |
| 9 | <i>Upper Limit STOP; Normally Closed</i> | <i>Lower Limit STOP; Normally Closed</i> | <i>Micro-Positioning Control Multiplier 1</i> | <i>Zero Servo Command</i> |
| A | <i>Upper Limit STOP; Normally Closed</i> | <i>Lower Limit STOP; Normally Closed</i> | <i>Micro-Positioning Control Multiplier 1</i> | <i>Weight Measurement Command</i> |
| B | <i>Swift-Lift Enable</i> | <i>Torque Limit Acceleration/Deceleration</i> | <i>Micro-Positioning Control Multiplier 1</i> | <i>Micro-Positioning Control Multiplier 2</i> |
| C | <i>Alternate Torque Limit</i> | <i>Torque Limit Acceleration/Deceleration</i> | <i>Micro-Positioning Control Multiplier 1</i> | <i>Upper Limit SLOW; Normally Closed</i> |
| D | <i>Zero Servo Command</i> | <i>Load Float Time Extension</i> | <i>Micro-Positioning Control Multiplier 1</i> | <i>Micro-Positioning Control Multiplier 2</i> |
| E | <i>Alternate Speed Reference Upper Limit</i> | <i>Serial/Inverter Command Changeover</i> | <i>Micro-Positioning Control Multiplier 1</i> | <i>Alternate Torque Limit</i> |

Table 5.5: G5IN4 Digital Multi-Function Input Sets (0 through F) (Software 14910, 14911)

| First Digit (From Left) You Enter | Multi-Function Input Assigned to Each Terminal | | | |
|-----------------------------------|---|---|---|---|
| | Terminal 1 | Terminal 2 | Terminal 3 | Terminal 4 |
| 0 | No function | No function | No function | No function |
| 1 | Upper Limit–SLOW DOWN; Normally Closed | Upper Limit–STOP; Normally Closed | Lower Limit–SLOW DOWN; Normally Closed | Lower Limit–STOP; Normally Closed |
| 2 | Upper Limit–SLOW DOWN; Normally Open | Upper Limit–STOP; Normally Open | Lower Limit–SLOW DOWN; Normally Open | Lower Limit–STOP; Normally Open |
| 3* | Multi-Step Speed 2 | Multi-Step Speed 3 | Multi-Step Speed 4 | Multi-Step Speed 5 |
| 4* | Hold function (2nd step of Three-Step Infinitely Variable). | Acceleration function (2nd step of Two-Step Infinitely Variable or 3rd step of Three-Step Infinitely Variable). | Micro-Positioning Control Multiplier 1 | Upper Limit–STOP; Normally Closed |
| 5 | Upper Limit–STOP Normally Closed | Upper Limit–SLOW DOWN; Normally Closed | Lower Limit–STOP; Normally Closed | Lower Limit–SLOW DOWN; Normally Closed |
| 6 | Upper Limit–STOP; Normally Open | Upper Limit–SLOW DOWN; Normally Open | Lower Limit–STOP; Normally Open | Lower Limit–SLOW DOWN; Normally Open |
| 7* | Multi-Step Speed 5 | Multi-Step Speed 4 | Multi-Step Speed 3 | Multi-Step Speed 2 |
| 8* | Upper Limit–STOP; Normally Closed | Micro-Positioning Control Multiplier 1 | Acceleration function (2nd step or Two-Step Infinitely Variable or 3rd step of Three-Step Infinitely Variable). | Hold function (2nd step of Three-Step Infinitely Variable). |
| 9 | Upper Limit–STOP; Normally Closed | Lower Limit–STOP; Normally Closed | Micro-Positioning Control Multiplier 1 | Zero Servo Command |
| A | Upper Limit–STOP; Normally Closed | Lower Limit–STOP; Normally Closed | Micro-Positioning Control Multiplier 1 | Weight Measurement Control |
| B | Ultra-Lift Enable | Torque Limit Acceleration/ Deceleration | Micro-Positioning Control Multiplier 1 | Micro-Positioning Control Multiplier 2 |
| C | Alternate Torque Limit Multiplier | Acceleration and Deceleration Changeover Time | Micro-Positioning Control Multiplier 1 | Upper Limit–SLOW DOWN; Normally Closed |
| D | Zero Servo Command | Torque Limit Acceleration/ Deceleration | Micro-Positioning Control Multiplier 1 | Micro-Positioning Control Multiplier 2 |
| E | Alternate Upper Limit Frequency Reference | Serial/Inverter Run and Speed Reference Changeover | Micro-Positioning Control Multiplier 1 | Alternate Torque Limit Multiplier |
| F | No function | No function | No function | No function |

* If using the G5IN4 to input speed references, A1-04 should be set for Data 7 (not used). This will help to avoid and OPE03 fault caused by having more than one terminal programmed with the same data.

Table 5.6: Enabling/Disabling Decision Table for C9-02

| Input for Terminal 1 | Input for Terminal 2 | Input for Terminal 3 | Input for Terminal 4 | Fourth Digit (From Left) You Enter |
|-----------------------------|-----------------------------|-----------------------------|-----------------------------|---|
| <i>E</i> | D | D | D | 1 |
| D | <i>E</i> | D | D | 2 |
| <i>E</i> | <i>E</i> | D | D | 3 |
| D | D | <i>E</i> | D | 4 |
| <i>E</i> | D | <i>E</i> | D | 5 |
| D | <i>E</i> | <i>E</i> | D | 6 |
| <i>E</i> | <i>E</i> | <i>E</i> | D | 7 |
| D | D | D | <i>E</i> | 8 |
| <i>E</i> | D | D | <i>E</i> | 9 |
| D | <i>E</i> | D | <i>E</i> | A |
| <i>E</i> | <i>E</i> | D | <i>E</i> | B |
| D | D | <i>E</i> | <i>E</i> | C |
| <i>E</i> | D | <i>E</i> | <i>E</i> | D |
| D | <i>E</i> | <i>E</i> | <i>E</i> | E |
| <i>E</i> | <i>E</i> | <i>E</i> | <i>E</i> | F |

Key Enable = *E*
 Disable = D

Weight Measurement Function Description and Analog Output/Display Device Calibration Procedure

Weight Measurement

The IMPULSE•VG+ Series 2 includes a Weight Calculation function that can be used in hoisting applications. The weight measurement calculation is based on motor torque at a constant speed. The drive must pause the acceleration, wait for the torque to stabilize and then perform the weight calculation based on the system tare values. The function takes a reading one time per lift (Raise Run command) when C10-01 = 1 or 3 (Automatic) or it can be configured to take a reading at any speed with a Multi-function input when C10-01 = 2 or 3 (Manual). The calculated weight can be displayed on the keypad of the hoist drive or by an external display device connected to an analog output of the hoist drive.

NOTE: Weight Calculations will be more consistent when a weight measurement is calculated at the same speed every time. Example: C10-01 = 1, Weight measurement is always calculated at C5-04 speed. It is important to note that after the load has been rigged, it should be suspended and the brakes should be set on the hoist. When the next raise command is given, the hoist is now ready to calculate the load weight. The function only works in the Raising motion (Fwd Run). If extreme accuracy is required, a load cell should be used. The Weight Measurement function of the hoist drive should be within 5% or better accuracy of the rated capacity.

| Parmtr Code | Display | Function | Range | Initial Value | Access Level |
|-------------|--|---|-------------|---------------|--------------|
| C10-01 | Load Weight 0/1 | Determines whether Load Weight is enabled. | 0~3 | 0 | Adv |
| | 0 Disabled | | | | |
| | 1 Enabled at C5-04 (Automatic for the duration of C5-12 + C5-13) | | | | |
| | 2 Enabled at MFI | | | | |
| | 3 Both Auto & MFI | | | | |
| C10-02 | TRQ Pri Delay | Torque Output Calculation primary delay time. | 0–1000 msec | 200 | Adv |
| C10-03 | LW Display Hold | | 0, 1 | 0 | Adv |
| | 0 Hold Display | Until next run command is on | | | |
| | 1 Hold Disp 3 sec | | | | |
| C10-04* ** | LW Conversion | Multiplier of torque output calculation for display. Data is n0000, so multiplier is 10000; “n” is decimal point. | 00000–39999 | 0 | Adv |
| C10-05 | Full Load TRQ | Percentage of Torque Output that is defined as Full-Load Torque Output. | 0.0–200.0% | 100.0 | Adv |
| C10-06 | No Load TRQ | Percentage of Torque Output that is defined as No-Load Torque Output. | 0.0–200.0% | 0.0 | Adv |
| C10-07** | Line 2 Display | Determines “weight” measurement units in which the parameter settings will be expressed. The unit abbreviations appear on line 2 of the display | 0~4 | 0 | Adv |
| | 0 tons | | | | |
| | 1 pounds | | | | |
| | 2 kilograms | | | | |
| | 3 metric tons | | | | |
| | 4 percent load | | | | |
| H1-01~06 | Terminal 3~8 = 44 | Weight Measurement enable by Multi-Function Input. | | | Adv |

*For an example, please refer to Table 5.19 on page 5-106.

** Used for keypad display; consult factory for assistance.

System Tare and Calibration

1. Attach all of the under hook attachments that are required during **normal** lifting (Chains, Slings, spreader beam, etc.). Remove the load from the bottom block. If there is a spreader beam or other lifting device that is **constantly** attached to the bottom block, it may be left in place. If the lifting device changes, it should be removed for this procedure and the known weight of the lifting device used for each lift should be manually subtracted from weight that is calculated by the hoist drive.
2. Run the **Unloaded** hoist in the raise direction at the speed that the weight will be calculated at. For example: If C10-01 = 1, then the hoist will automatically pause at the speed programmed in parameter C5-04 (6 Hz is the factory setting) while calculating the weight on the hook. This is the speed the hoist should be run at. An easy method would be to set the first speed point equal to C5-04 or, if using an analog speed reference, then program B2-02 (minimum speed) so that it is equal to C5-04.
3. Record the torque reading being displayed by the monitor parameter U1-09 (Torque Reference). Repeat this step several times and record the average “No Load Torque” in parameter C10-06 (No Load Torque).
4. Attach all of the under hook attachments that are required during **normal** lifting (Chains, Slings, spreader beam, etc.). Rig the **FULL** load that the hoist and weight measurement system will be expected to calculate. If the rigging used for the full load is different than that used in steps 2 and 3, it will need to be added to the known weight being lifted to obtain an accurate total weight at a later time.
5. Run the **Loaded** hoist in the raise direction at the speed that the weight will be calculated at. See Step 2 for an example.
6. Record the torque reading being displayed by the monitor parameter U1-09 (Torque Reference). Repeat this step several times and record the average “Full Load Torque” in parameter C10-05 (Full Load Torque).
7. The monitor parameter U1-29 should now be displaying a value when lifting a full load. This value is a raw number that could later be converted into a meaningful weight to be displayed on the keypad. For this procedure, it is not imperative that the number is converted to tons or pounds. Most importantly, it should read a value of zero or very close to zero when lifting no load and should be relatively consistent when lifting the same weight repeatedly.

Setting up an External Display Device

NOTE: This procedure assumes that the System Tare and Calibration procedure has been completed. The setup of parameter C10-03 and C10-07 should be returned to the factory default settings for this procedure or may be skipped entirely if the displayed weight does not need to be read on the keypad of the hoist drive. C10-03 and C10-07 = 0. The external display device should be configured to accept a 0 - 10VDC input where 0 V = no load and 10V - Full load or 125% load. (This may be site specific.)

1. Program the desired analog output terminal (21 or 23) for 'Load Weight'

Example: H4-01 = 29 (Terminal 21) or H4-04 = 29 (Terminal 23).

2. Remove the load from the bottom block. If there is a spreader beam or other lifting device that is constantly attached to the bottom block, it may be left in place. If the lifting device changes, it should be removed for this procedure and the weight of the lifting device used for each lift should be manually subtracted from weight that is calculated by the drive.
3. Lift **no-load** and monitor the 'Weight Measurement' on U1-29 on the keypad. The keypad digital display should read 0; however, if it does not, lower C10-06 until the keypad digital display reads zero. Re-test as necessary to get as close to 0 as possible.
4. After lifting **no-load** again, read the weight displayed on the display device. If the displayed weight is greater than 0, begin to add a **negative bias** to terminal 21 by adjusting H4-03 down from 0.00. It will be in -xx.x format. To switch from a positive bias to a negative bias, move the cursor to the far left digit and press the up arrow key, which will display the - sign. As the **negative bias** is increased, the weight displayed on the digital display device will decrease. Continue to add **negative bias** until the weight displayed on the digital display device reads as close to 0 as possible without going negative.
5. Pick up a known load of approximately 50% or greater and read the weight displayed on the display device. If the indicated weight does not match the actual weight, adjust H4-02 or H4-05 (Terminal 21 or 23 Gain) to obtain the required reading. H4-02 and H4-05 are gain multiplier parameters for the respective analog output and will raise or lower the 0-10V dc signal to the display device.
6. Re-test with no load. If the weight displayed on the display device does not equal zero, re-adjust the negative bias at H4-03.
7. This procedure may be repeated as many times as necessary until the correct combination of gain and bias is found to make the system within tolerance at the high and low end of maximum capacity of the hoist.

Slack Cable Detection

IMPULSE•VG+ Series 2 offers Slack Cable Detection in the hoist application. The Slack Cable condition is detected when the torque output is drastically reduced and has dipped below a set-point (C11-03) level. When Slack Cable condition occurs, the output action is defined by the C11-02 which has 6 selections.

The Slack Cable Detection is not executed, unless both of the following conditions are true:

- The output frequency is between C11-04 and C11-06.
- The Slack Cable Detection delay time is between C11-05 and C11-07.

Setup Procedure:

- To set the Slack Cable Detection torque level (C11-03), by lowering the hoist without load at a constant speed that the hoist would normally run during the operation. Monitor and record the torque reference (U1-09). Repeat above operation several times to ensure an accurate reading.
- Then Set C11-03 = [(U1-09)-2].
- Enable Slack Cable Detection by setting the C11-01 to 1.
- Select output action when Slack Cable is detected by defining C11-02.

| Parmtr Code | Display | Function | Range | Initial Value | Access Level |
|-------------|-------------------|---|-------|---------------|--------------|
| C11-01 | Slack Cable 0/1 | (For Hoist Application) Determines whether Slack Cable Detection is enabled. | 0~1 | 0 | Adv |
| | 0 Disabled | | | | |
| | 1 Enabled | | | | |
| C11-02 | Action at SLC | Multi-function output that occurs at Slack Cable Detection. For all Selections, RAISE command is permitted. | 0~5 | 2 | Adv |
| | 0 No Action | Alarm Only | | | |
| | 1 No Act/C3-04 | Next LOWER command is at Lower Limit 1 speed (C3-04). | | | |
| | 2 Decel/C3-04 | Decelerate to Lower Limit 1 Speed C3-04. Continued LOWER commands allowed, but at C3-04. | | | |
| | 3 Decel/No Opr | Decelerate to Lower Limit 1 Speed C3-04. Continued LOWER commands are <i>not</i> allowed. | | | |
| | 4 Dec Stop/C3-04 | Decel (by C3-05) to Lower Limit 1 Speed C3-04. Continued LOWER commands allowed, but at C3-04. | | | |
| | 5 Dec Stop/No Opr | Decel (by C3-06) to stop. Continued LOWER commands are <i>not</i> allowed. | | | |

| Parmtr Code | Display | Function | Range | Initial Value | Access Level |
|--------------------|------------------|---|---------------|----------------------|---------------------|
| C11-03 | SLC Detect Torq | Percentage of Output Torque below which the enabled Slack Cable Detection is activated—as long as the Frequency output is between C11-04 and C11-06, and the delay time is between C11-05 and C11-07. | 0–100% | 30 | Adv |
| C11-04 | SLC Detect Spd 1 | The Frequency Output that is required for the enabled Slack Cable Detection to be activated. It corresponds to Slack Cable Detection Delay Time 1 (C11-05). | 0–150Hz | 2 | Adv |
| C11-05 | SLC Delay Time 1 | The delay time before the enabled Slack Cable Detection can be activated. It corresponds to Slack Cable Detection Speed 1. Prevents false outputs. | 0.00–2.55sec. | 0.50 | Adv |
| C11-06 | SLC Detect Spd 2 | The Frequency Output below which the enabled Slack Cable Detection can be activated. It corresponds to Slack Cable Detection Delay Time 2 (C11-07). | 0–150Hz | 60 | Adv |
| C11-07 | SLC Delay Time 2 | The delay time before the enabled Slack Cable Detection can be activated. It corresponds to Slack Cable Detection Speed 2. Prevents false outputs. | 0.00–2.55sec. | 0.10 | Adv |

Delay Timers

This function is used in trolley or bridge applications. It can reduce the mechanical brake wear when the operator tries to position a load. This function is available only in traverse mode and the constant B3-03 must be set to 4 (Ramp With Timer).

| Parmtr Code | Display | Function | Range | Initial Value | Access Level |
|-------------|-----------------|--|---------------|---------------|--------------|
| C12-01 | Brake Jog Delay | Brake set delay time at Jog Control input. | 0.0–100.0 sec | 0.0 sec | Adv |
| C12-02 | Brake Run Delay | Brake set delay time at RUN input. | 0.0–100.0 sec | 0.0 sec | Adv |

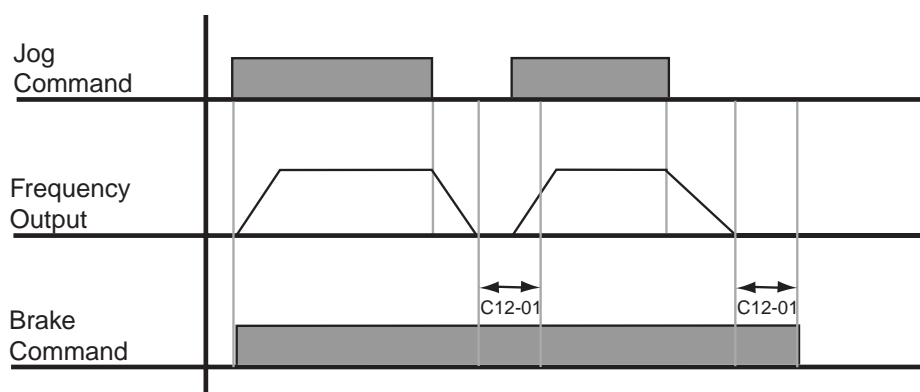

Figure 5-34: Brake Delay Timers

NOTE: The Jog control input is a multi-function input. It is enabled by programming data 16 or 17 in H1-01~06.

Timer Function

- The timer function is enabled when the timer function input (setting: 4A) and the timer function output (setting: 12) are set for the multi-function input and multi-function output respectively.
- These inputs and output serve as general purpose I/O. Chattering of sensors, switches, contactors, etc., can be prevented by setting a delay time.
- When the timer function input **ON** time is longer than the value set for **C12-03** (Timer function ON-Delay Time), the timer function output turns **ON**.
- When the timer function input **OFF** time is longer than the value set for **C12-04** (Timer function OFF-Delay Time), the timer function output turns **OFF**.
- See Parameters page 5-35

NOTE: The timer function is only available in software version 14912.5 or greater.

| Parmtr Code | Display | Setting Range | Factory Default Setting | Flux Vector | Access Level |
|-------------|-------------------------------|---------------|-------------------------|-------------|--------------|
| C12-03 | Timer function ON-Delay Timer | 0.0~300.0 | 0.0 | | Adv. |
| C12-04 | Timer function OFF-Delay Time | 0.0~300.0 | 0.0 | | Adv. |

Inching Control

Inching Control Function can be enabled by programming data 18, 19, and 1A respectively to the Multi-Function input terminals (H1-01~06). The frequency reference used during inching is determined by B1-09 (Jog Reference).



CAUTION

A directional input is not needed on terminals 1 or 2.

| Parmtr Code | Display | Function | Range | Initial Value | V/F Access | Open Loop Vector Access |
|-------------|----------------------------|------------------------------------|---------------|---------------|------------|-------------------------|
| C13-01 | Inch Run Time | Inching Control run time. | 0.00–2.55 sec | 1.00 | Adv | Adv |
| C13-02 | Repeat Delay T | Inching Control repeat delay time. | 0.00–2.55 sec | 1.00 | – | Adv |
| H1-01~06 | Terminal x Sel | | | | Adv | Adv |
| | 18 Inching Forward Command | | | | | |
| | 19 Inching Reverse Command | | | | | |
| | 1A Inching Repeat Command | | | | | |

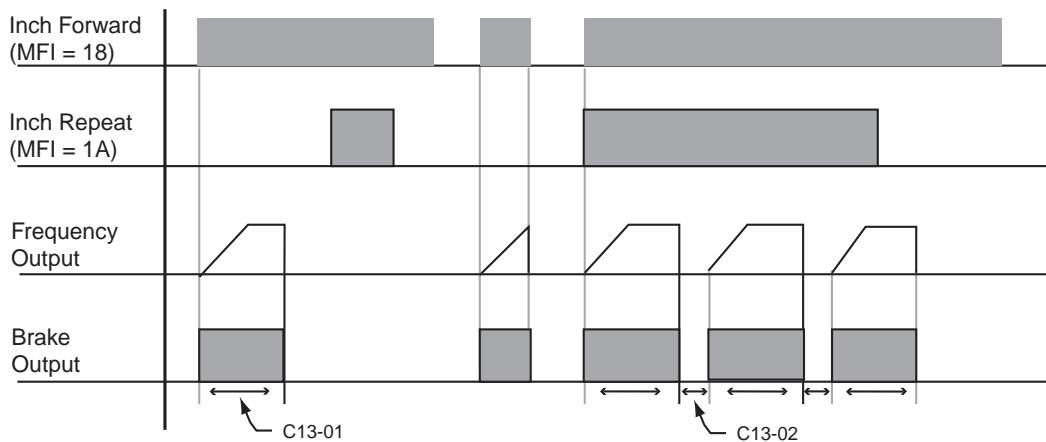

Figure 5-35: Inching Function and Inching Repeat

Tuning

- D1 DC Injection
- D2 Automatic Slip Compensation
- D4 ASR Tuning
- D5 Torque Control
- D6 Droop Control
- D8 Dwell Function
- D9 S-Curve Acceleration/Deceleration
- D10 Carrier Frequency
- D12 Factory Tuning

DC Injection

DC Injection can be used to stop a motor whose rotational direction is uncertain at start-up.

With ramp to stop enabled (B3-03=0), upon removal of the run command the IMPULSE•VG+ Series 2 drive controls motor deceleration according to the Decel Time setting, until output frequency reaches the DC Injection Braking Start Frequency (D1-01 setting). Then the IMPULSE•VG+ Series 2 drive output is turned off and DC injection current is applied to the motor. The effective DC injection time and current should be set to provide adequate stopping without excessive motor heating. The DC injection voltage is determined by the DC injection braking current and motor impedance.

| Parmtr Code | Display | Function | Range | Initial Value | Access Level |
|--------------------|----------------------------|---------------------------------------|----------------|----------------------|---------------------|
| D1-01 | DCInj Start Freq | DC Injection braking frequency start. | 0.0–10 Hz | 1.5 | Adv |
| D1-03 | DCInj@Start | DC Injection braking time. | 0.00–10.00 sec | 0.00 | Adv |
| D1-04 | DCInj Time@Stop | DC Injection braking time at stop. | 0.00–10.00 sec | 0.05 | Adv |
| D1-05 | DC Injection P Gain | | 0.00–1.00 | 0.05 | Factory |
| D1-06 | DC Injection Integral Time | | 0–1000 msec | 100 | Factory |
| D1-07 | DC Injection Limit | | 0.0–30% | 15.0 | Factory |

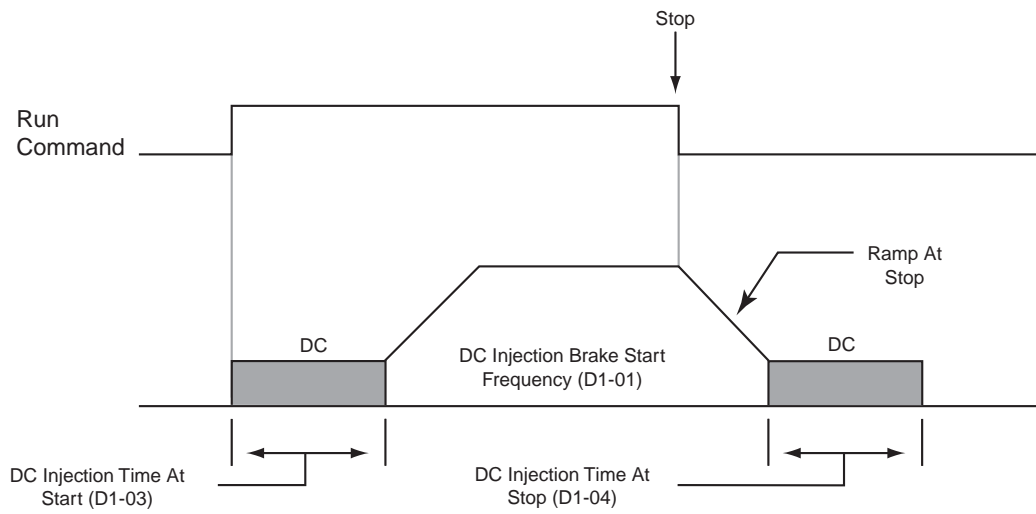

Figure 5-36: DC Braking Sequence

Automatic Slip Compensation

As the load becomes larger, the motor speed is reduced and the motor slip increases. The slip compensation function keeps the motor speed constant under varying load conditions. D2-01 sets the slip compensation gain. When the gain is “1.0”, the output frequency is increased by 1% of the E1-06 setting at rated current. A setting of “0.0” results in no slip compensation. D2-02 and D2-03 affect this gain.

| Parmtr Code | Display | Function | Range | Initial Value | Access Level |
|-------------|----------------|-------------------------------|---------|---------------|--------------|
| D2-01 | Slip Comp Gain | Slip compensation multiplier. | 0.0–2.5 | 1 | Adv |

Automatic Speed Regulator (ASR) Tuning

| Parmtr Code | Display | Function | Range | Initial Value | Access Level |
|-------------|--------------|--------------------------|------------------|---------------|--------------|
| D4-01 | ASR P Gain 1 | ASR Proportional Gain 1. | 1.00–300.00 | 30 | Adv |
| D4-02 | ASR I Time 1 | ASR Integral Time 1. | 0.00–10.000 sec. | 0.500 | Adv |

Parameters D4-01 and D4-02 provide adjustments to enable the optimum performance during load disturbances. The proportional gain (D4-01) adjusts the amount of instantaneous droop as a function of loss, and provides dampening from load disturbances such as speed reference change, or a change in load. The integral time (D4-02) adjusts the response time of the IMPULSE•VG+ Series 2 to the load disturbances.

NOTE: Speed control response is increased by increasing the proportional gain setting and decreasing the integral time. However, instability or hunting may occur between the IMPULSE•VG+ Series 2 and the load if D4-01 (ASR Proportional Gain) is set too high, or D4-02 (ASR Integral Time) is set too low.

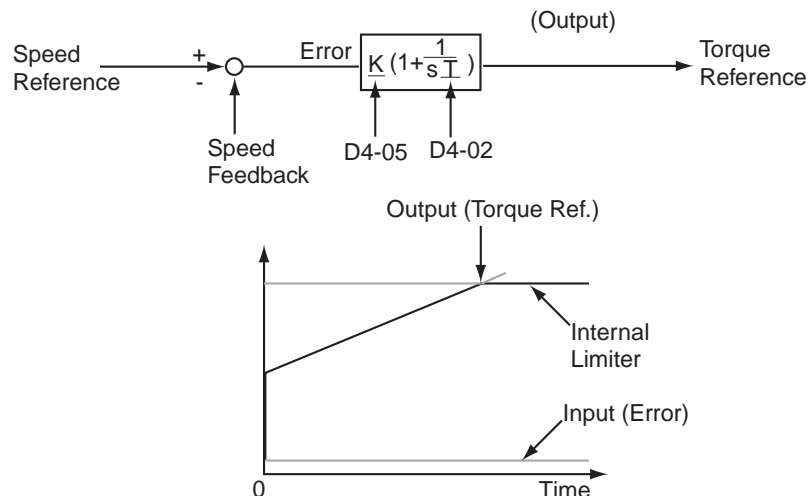

Figure 5-37: Automatic Speed Regulator (ASR) Tuning

| Parmtr Code | Display | Function | Range | Initial Value | Access Level |
|--|------------------|--------------------------------|------------------|---------------|--------------|
| D4-03 | ASR P Gain 2 | ASR Proportional Gain 2. | 1.00–300.0 | 30 | Adv |
| D4-04 | ASR I Time 2 | ASR Integral Time 2. | 0.000–10.000 sec | 0.100 | Adv |
| D4-06 | ASR Delay Time | ASR Output Primary Delay Time. | 0.000–0.500 sec | 0.004 | Adv |
| Mechanical backlash in an application can cause secondary current (I_2) reference variations in the motor's rotor. This condition can prevent the desired adjustment of ASR parameters. The output delay time constant is used to increase the stability of the system allowing a wider setting range of ASR parameters. | | | | | |
| D4-07 | ASR Gain SW Freq | ASR Gain Switching Frequency. | 0.0–150.0 Hz | 0.0 | Adv |
| D4-08 | ASR I Limit | ASR Integral Limit. | 0–400% | 400 | Adv |

Parameter D4-03 is used as an additional proportional gain adjustment, and parameter D4-04 determines the response time for Proportional Gain 2 (D4-03).

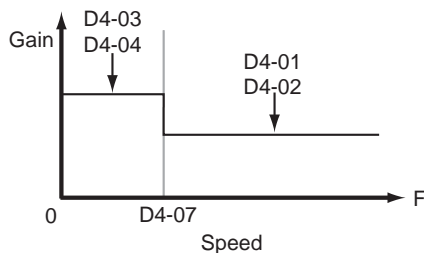

Figure 5-38: Proportional Gain

NOTE: When D4-07= “0,” proportional gain 1 (D4-01) and integral time 1 (D4-02) are selected.

Torque Control

Please consult factory for application assistance regarding torque control. Torque control should not be applied on a vertical hoist

| Parmtr Code | Display | Function | Range | Initial Value | Access Level |
|--|-------------------|---|------------|---------------|--------------|
| D5-01 | Torque Control | Determines whether Speed or Torque Control is selected. | 0–1 | 0 | Factory |
| | 0 Speed Control | Speed Control enabled with torque limit | | | |
| | 1 Torque Control | Torque control enabled with speed limit. | | | |
| Speed/torque control selection can also be made by using a multi-function input select (H1-XX=39 speed-torque control changeover). | | | | | |
| D5-02 | Torque Ref Filter | Primary delay time for Torque Reference Input. | 0–1000msec | 0 | Factory |

This function is used to avoid excessive changes in torque, which may be caused by abnormal resonance when the torque reference changes rapidly.

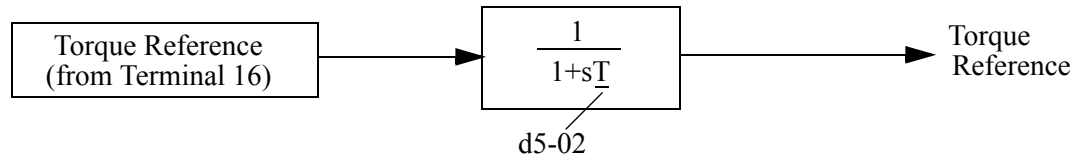

| Parmtr Code | Display | Function | Range | Initial Value | Access Level |
|-------------|-------------------|--|-----------|---------------|--------------|
| D5-03 | Speed Limit Sel | Speed Limit Selection (See figure below) | 0~1 | 1 | Factory |
| | 1 Analog Input | | | | |
| | 2 Program Setting | | | | |
| D5-04 | Speed Lmt Value | Speed Limit Value (% of E1-04) | -120~120% | 0 | Factory |
| D5-05 | Speed Lmt Bias | Speed Limit Bias (% of E1-04) | 0~120% | 10 | Factory |
| D5-06 | Ref Hold Time | Speed/Torque Switching Timer | 0~120% | 0 | Factory |

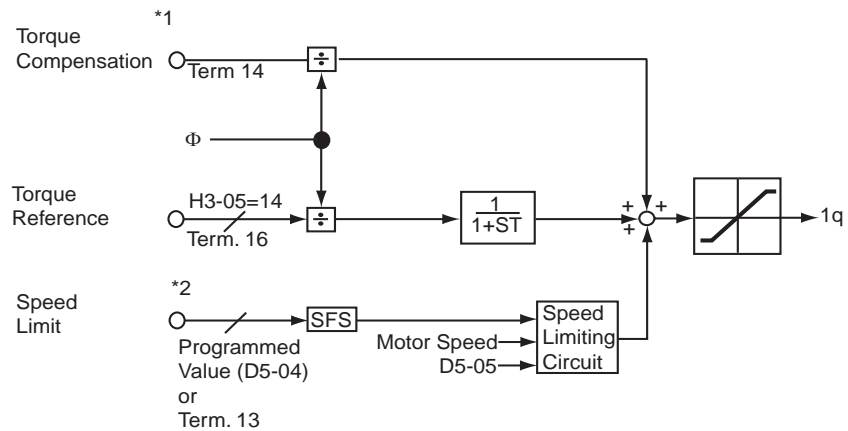

Figure 5-39: Torque Control Block Diagram

*1: When speed limit selection (D5-03) is set to “1”, the master frequency reference input from terminal 13, 14 or 16 becomes the speed limit selection (D5-03) is set to “2”, the set value of D5-04 becomes the speed limit.

*2: When terminal 14 or 16 function selection is set to torque compensation (H3-09= “14”), terminal 14 or 16 set value can be used as the torque compensation value.

Speed/Torque Control Switching

Speed control or torque control can be selected “on the fly” by using the multi-function input speed/torque control selection command (H1-XX = “39”).

| Terminal Number | Parameter Number | Setting | Description |
|-----------------|------------------|---------|---|
| 8 | H1-06 | 39 | Speed/torque control selection |
| 13 | B3-01 | 1 | Frequency reference selection (terminals 13, 14, or 16) |
| | D5-03 | 1 | Speed limit selection (terminals 13, 14, or 16) |
| 16/14 | H3-05/H3-09 | 13 | Torque reference/torque limit |

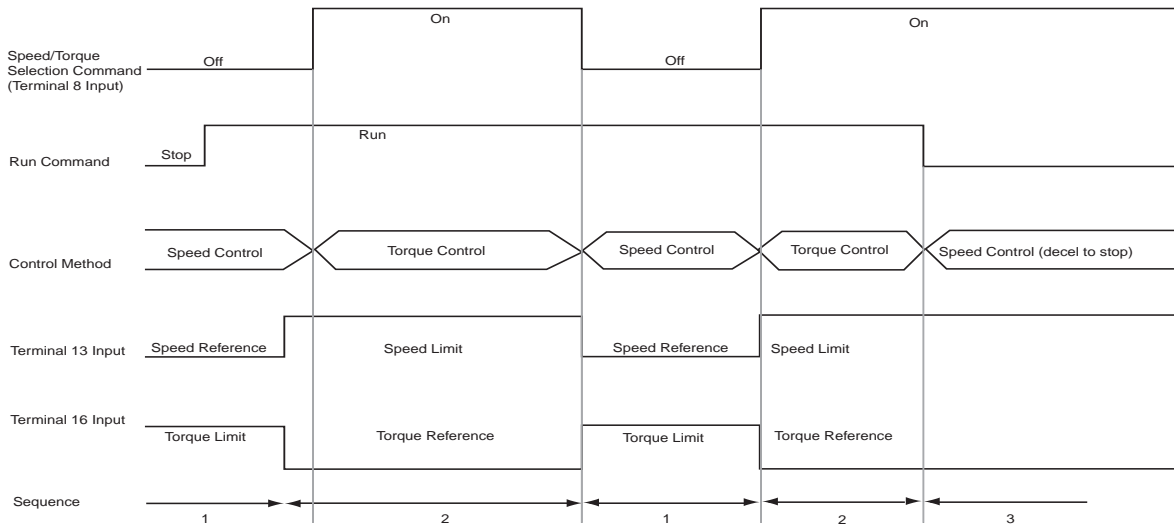

Figure 5-39: Speed/Torque Control Selection Timing Diagram

1. When the speed/torque control selection contact is OFF, speed control is activated.
 - Speed reference during speed control depends on the frequency reference selection (B3-01) setting. To use terminal 13, 14 or 16 as the master frequency reference, set B3-01 to “1.”
 - Torque limit during speed control is the smaller of the absolute value of terminal 14 or 16 torque limit, or the values set in the torque limit parameters (C7-01 to C7-04) is used as the torque limit.
 - When a stop command is given during speed control, speed control is maintained as the motor decelerates to stop and the smaller of the absolute value of the terminal 16 torque limit, or the values set in the torque limit parameters (C7-01 to C7-04) is used as the torque limit.
2. When the speed/torque control selection is ON, torque control is activated.
 - Speed limit during torque control is the master frequency reference at terminal 13, 14 or 16 when speed limit selection (D5-03) is set to “1”, and is the speed limit value (D5-04) when

D5-03 = “2”, regardless of the frequency reference selection (B3-01) setting.

- During torque control, the terminal 14 or 16 analog input value becomes the torque reference.
3. By giving a stop command during torque control, operation changes to speed control automatically, and the motor decelerates to stop. The torque limit during deceleration to stop becomes the values set in the torque limit parameters (C7-01 to C7-04).

NOTE: The control mode actually changes after the speed/torque control selection command changes and the reference delay timer (D5-06) elapses. The speed reference/speed limit and the torque limit/torque reference are stored in the inverter until the time set to D5-06 elapses.

Droop Control

The Drooping function reduces the motor speed based on the load torque of the motor. The actual amount of motor speed reduction is based on the ratio of the amount of motor torque and maximum output frequency (E1-04).

The Droop Delay Time D6-02 sets the response time for the drooping function. Decreasing the Droop Delay Time will cause the response to become quicker, however, instability may occur.

| Parmtr Code | Display | Function | Range | Initial Value | Access Level |
|--------------------|------------------|---|----------------|----------------------|---------------------|
| D6-01 | Droop Quantity | Sets the motor speed reduction when torque output equals 100% | 0.0 - 100.0 | 0 | Adv |
| D6-02 | Droop Delay Time | Sets the response time for the drooping function | 0.03 - 2.0 sec | 0.05 | Adv |

Dwell Function

The Dwell Function is used to temporarily hold the output frequency at a set reference for a set time. This function can be used when driving a motor with a heavy starting load. This pause in acceleration reduces traditionally high starting current. For software version 14912.5 or greater this function can be enabled or disabled “on the fly” by programming a terminal-H1-xx=4C.

NOTE: This function should not be used for hoists.

| Parmtr Code | Display | Function | Range | Initial Value | Access Level |
|-------------|--------------------|---|--------------|---------------|--------------|
| D8-01 | Dwell Ref @ Start | Sets Dwell frequency reference at start. | 0.0–150.0 Hz | 0 | Adv |
| D8-02 | Dwell Time @ Start | Sets the time duration for the Dwell function at start. | 0.0–10.0 sec | 0 | Adv |
| D8-03 | Dwell Ref @ Stop | Sets dwell frequency Reference at stop. | 0.0–150.0 Hz | 0 | Adv |
| D8-04 | Dwell Time @ Stop | Sets the time duration for the Dwell function at stop. | 0.0–10.0 sec | 0 | Adv |

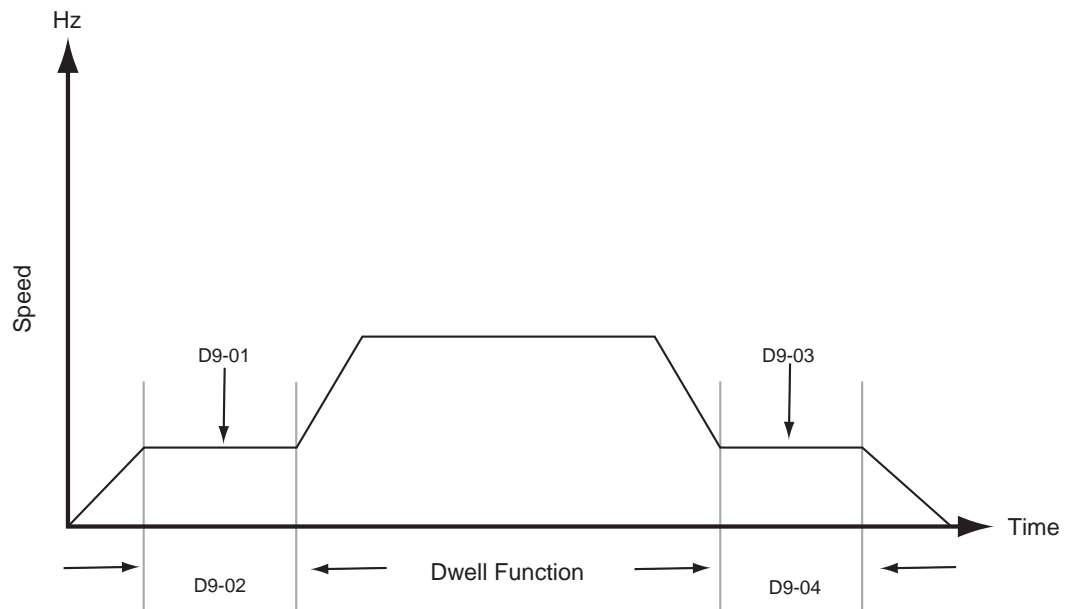

Figure 5-41: Dwell Function

S-Curve Acceleration/Deceleration

A S-Curve pattern is used to reduce shock and provide smooth transitions during machine acceleration and deceleration. S-Curve characteristic time is the time from the output frequency to the set accel/decel time. See S-Curve Characteristic timing diagrams below and on the following page.

| Parmtr Code | Display | Function | Range | Initial Value | Access Level |
|-------------|-------------------|----------------------------------|---------------|---------------|--------------|
| D9-01* | S-Crv Acc @ Start | Sets S-Curve time at Accel start | 0.00–2.50 sec | – | Adv |
| D9-02* | S-Crv Acc @ End | Sets S-Curve time at Accel end | 0.00–2.50 sec | – | Adv |
| D9-03* | S-Crv Dec @ Start | Sets S-Curve time Decel start | 0.00–2.50 sec | – | Adv |
| D9-04 | S-Crv Dec @ End | Sets S-Curve time at Decel end | 0.00–2.50 sec | 0 | Adv |

*Initial value is determined by X-Press Programming (Table 4.1 to 4.12).

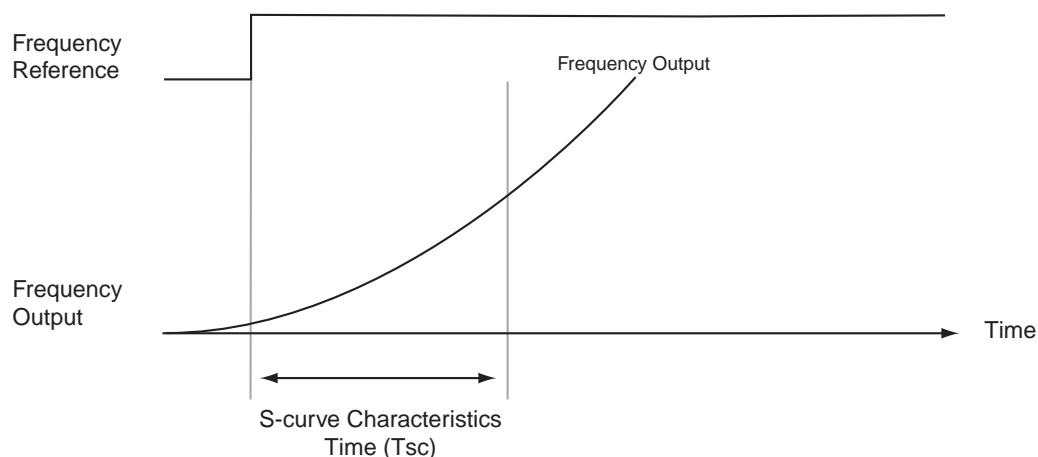

Figure 5-42: S-Curve Characteristic Timing Diagram

The figure below shows FWD/REV run switching during deceleration to stop. The S-curve function will add time to the acceleration and deceleration. Time to accelerate from the minimum frequency to the maximum frequency (total acceleration) = $B5-01 + (D9-01 + D9-02)/2$.



CAUTION

CAUTION Accel/Decel times will be extended.

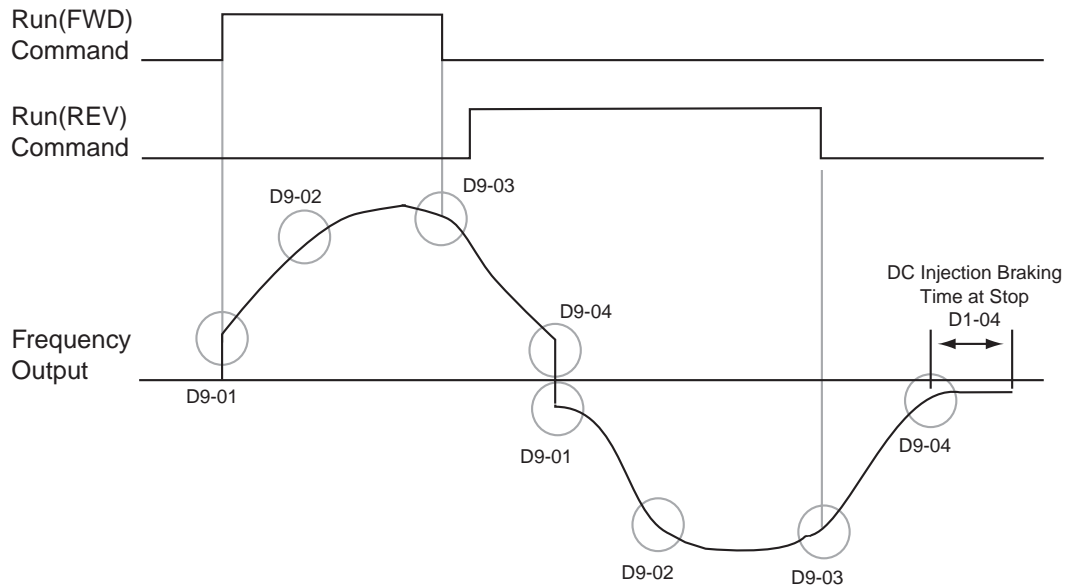

Figure 5-43: S-Curve Characteristics—FWD/REV Operation

Carrier Frequency

This function sets the inverter output transistor switching frequency (Carrier Frequency). Increasing the carrier frequency reduces motor noise.

| Parmtr Code | Display | Function | Range | Initial Value | Access Level |
|--------------------|-----------------------|--------------------------------|--------------|----------------------|---------------------|
| D10-01 | Carrier Frequency Max | Carrier frequency upper limit. | | 3 | Adv |
| | <i>0 0.4 kHz</i> | | | | |
| | <i>1 1.0 kHz</i> | | | | |
| | <i>2 1.5 kHz</i> | | | | |
| | <i>3 2.0 kHz</i> | | | | |
| | <i>4 2.5 kHz</i> | | | | |
| | <i>5 5.0 kHz</i> | | | | |
| | <i>6 10.0 kHz</i> | | | | |

Factory Tuning

During normal auto-tuning, the inverter is tuned while running at a carrier frequency of 2kHz. This parameter allows the user to specify the inverter's carrier frequency during auto-tuning. Adjustment may be necessary if "OC" fault is displayed after completion of auto-tuning.

| Parmtr Code | Display | Function | Range | Initial Value | Access Level |
|------------------------|--|---|--------------|--------------------------|-------------------------|
| D12-30 | Carrier in tune | Sets the carrier frequency during auto-tuning | | 0 | – |
| | <i>0 2kHz</i> | | | | |
| | <i>1 Adjustable by D10-01 (Fc Upper Limit)</i> | | | | |

Motor Parameters

- E1 V/f Pattern 1
- E2 Motor Set-up
- E3 Motor 2 Method
- E4 Motor 2 V/f Pattern
- E5 Motor 2 Set-up

Voltage/Frequency Pattern

| Parmtr Code | Display | Function | Range | Initial ⁽¹⁾ Value | Access Level |
|-------------|---------------|--------------------|---------------------|------------------------------|--------------|
| E1-01 | Input Voltage | Sets input voltage | 155-255/ 310-510 | 230/460 | User |

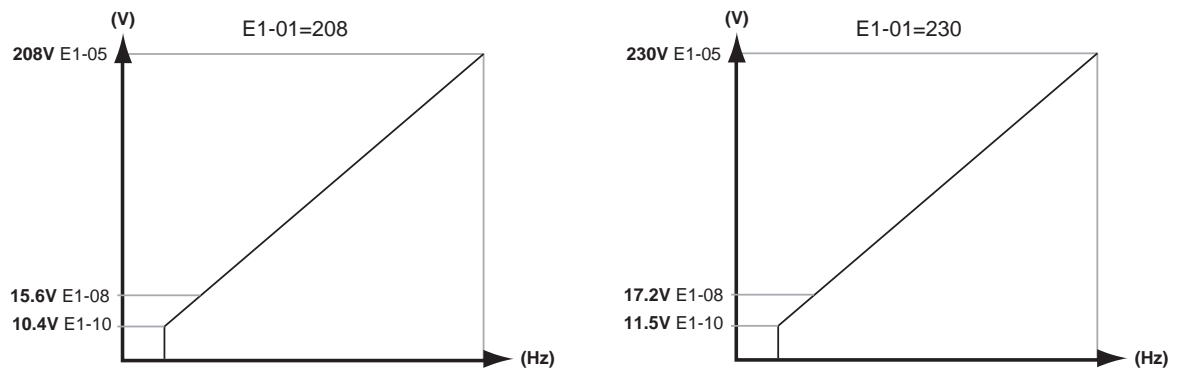

Figure 5-44: E1-01 Input Voltage

- When using flux vector control mode, the V/f pattern voltage values will be adjusted by the Auto-Tuning function.
- Factory setting is 230 (230V units), 460 (460V units) and 575 (575V units).

The setting E1-01 adjusts the overvoltage level, braking transistor turn on level and the stall prevention level during deceleration.

Table 5.7:

| Inverter Voltage | E1-01 Setting | Overvoltage Trip | | Braking Transistor | | Stall Level |
|------------------|---------------|------------------|-------|--------------------|------|-------------|
| | | Trip | Reset | On | Off | |
| 230 | 150-255 | 400V | 380V | 380V | 375V | 380V |
| 460 | ≥400 | 800V | 760V | 760V | 750V | 760V |
| 460 | <400 | 720V | 680V | 660V | 650V | 670V |
| 575 | >500V | 1040V | 990V | 990V | 970V | 960V |
| 575 | <500V | 990V | 940V | 860V | 840V | 830V |

Parameter E1-01 performs the above mentioned function in all three control modes.

| Parmtr Code | Display | Function | Range | Initial ⁽¹⁾ Value | Access Level |
|----------------------|----------------------------|---|---------------|------------------------------|--------------|
| E1-02* | Motor Selection | Identifies motor as fan-cooled or blower-cooled | | 1 | User |
| | 0 <i>Stf Fan Cooled</i> | | | | |
| | 1 <i>Std Blower Cooled</i> | | | | |
| E1-03 | <i>V/f Selection</i> | Select V/f Pattern | | F | - |
| E1-04 | Max Frequency | Maximum Frequency | 40.0–150.0 Hz | 60.0 | User |
| E1-05 ⁽²⁾ | Max Voltage | Maximum Voltage | 0.0–510.0 V | 460 | User |
| E1-06 | Base Frequency | Motor Base Frequency | 0.0–150.0 Hz | 60 | - |
| E1-09 | Min Frequency | Minimum Frequency | 0.0–150.0 Hz | 0.0 | User |
| E1-11 | Mid Frequency B | Midpoint Output Frequency B | 0.0–150.0 Hz | 0.0 | Adv |
| E1-12 | Mid Voltage B | Midpoint Output Voltage B | 0.0–510.0 V | 0.0 | Adv |
| E1-13 ⁽²⁾ | Base Voltage | Motor Base Voltage | 0.0–510.0 V | 0.0 | User |

* Initial value determined by X-Press Programming (Table 4.1 to 4.12).

⁽¹⁾ The initial value displayed here is for 460V class drives. For 575V class units, the initial value is 1.25 times that of 460V class units.

⁽²⁾ For 230V class units, the value is half that of 400V class units.

Motor Set-up

E2 constants define motor parameters. Normally, the default settings for E2 constants are determined by KVA selection (O2-04). In flux vector control the E2 constants will be set automatically during auto-tuning. If the control method is V/F (A1-02=0), the motor rated current should be entered into E2-01.

If auto-tuning cannot be performed, some E2 constants can be calculated using the motor's nameplate information.

Motor rated slip frequency (E2-02) can be calculated by using the following equation:

$$f_s = f - \frac{(N \cdot P)}{120}$$

Where... f_s : slip frequency (Hz)
 f : rated frequency (Hz)
 N : rated motor speed (rpm)
 P : number of motor poles

Motor terminal resistance E2-05 can be calculated by using the following equation:

$$r_t = r_p \cdot \frac{273 + (25^\circ\text{C} + T_i)/2}{273 + T_i}$$

Where... r_t : motor terminal resistance
 r_p : Phase-to-Phase resistance at insulation class temperature
 T_i : insulation class temperature ($^\circ\text{C}$)

| Parmtr Code | Display | Function | Range | Initial Value | Access Level |
|-------------|-------------------|--|-----------------------|---------------|--------------|
| E2-01 | Motor Rated FLA | Motor-rated current | 0.01–1500.0 A | * | User |
| E2-02 | Motor Rated Slip | Motor-rated slip frequency | 0.00–20.00 Hz | * | User |
| E2-03 | No-Load Current | Motor no-load current | 0.0–1500.0 A | * | User |
| E2-04 | Number of Poles | Number of poles in motor | 2–48 | 4 | Adv |
| E2-05 | Term Resistance | Motor terminal resistance | 0.000–65.000 Ω | * | Adv |
| E2-06 | Leak Inductance | Leakage Inductance | 0.0–30.0% | * | Adv |
| E2-07 | Saturation Comp 1 | Core-Saturation Compensation Coefficient 1 | 0.00–0.50 | * | Adv |
| E2-08 | Saturation Comp 2 | Core-Saturation Compensation Coefficient 2 | 0.00–0.75 | * | Adv |
| E2-09 | Mechanical Loss | Motor mechanical loss in percentage | 0.0–10.0% | * | Adv |

* Initial value is determined by O2-04 (kVA Selection)

Motor 2 Method

The Motor 2 method function allows one drive to control two separate motors which are coupled to separate motions. The output of the drive is switched from one motor to the other and a multi-function input (H1-XX=3D Motor 2 Select) informs the drive of which motor is being used.



WARNING

Do not switch between motors when the drive's output is on as it will damage the unit!

| Parmtr Code | Display | Function | Range | Initial Value | Access Level |
|-------------|---|------------------------|-------|---------------|--------------|
| E3-01 | Control Method <i>0 V/f control</i> <i>2 Open loop vector</i> | Motor 2 control method | 0–2 | 2 | Adv |
| E3-02 | Motion 2 <i>0 Traverse</i> <i>1 Standard Hoist</i> | Motor 2 motion | 0–2 | 1 | Adv |

Motor 2 Voltage/Frequency Pattern

| Parmtr Code | Display | Function | Range | Initial Value | Access Level |
|-------------|-------------------|---------------------------------------|---------------|---------------|--------------|
| E4-01 | V/f 2 Max freq | Maximum frequency for Motor 2 | 40.0–150.0 Hz | 60.0 | Adv |
| E4-02 | V/f 2 Max voltage | Maximum voltage for Motor 2 | 0.0–255.0 V | 230.0 | Adv |
| E4-03 | V/f 2 Base Freq | Base frequency for Motor 2 | 50.0–150.0 Hz | 60.0 | Adv |
| E4-04 | V/f 2 Mid Freq | Midpoint output frequency for Motor 2 | 0.0–150.0 Hz | 3.0 | Factory |
| E4-05 | V/f 2 Mid Voltage | Midpoint output voltage for Motor 2 | 0.0–255.0 V | 12.6 | Factory |
| E4-06 | V/f 2 Min Freq | Minimum output frequency for Motor 2 | 0.0–150.0 Hz | 0.5 | Factory |
| E4-07 | V/f 2 Min Voltage | Minimum output voltage for Motor 2 | 0.0–255.0 V | 2.3 | Factory |

Motor 2 Set-up

| Parmtr Code | Display | Function | Range | Initial Value | Access Level |
|--------------------|------------------|--|---------------|----------------------|---------------------|
| E5-01 | Motor2 Rated FLA | Motor-rated current for Motor 2 | 0.0–150.0 A | * | Adv |
| E5-02 | Motor2 Slip Freq | Motor-rated slip frequency for Motor 2 | 0.00–20.0 Hz | * | Adv |
| E5-03 | Motor2 No Load 1 | Motor no-load current for Motor 2 | 0.0–150.0 A | * | Adv |
| E5-05 | Motor2 Term Ohms | Motor terminal resistance for Motor 2 | 0.000–65.000Ω | * | Adv |
| E5-06 | Motor2 Leak | Leakage inductance for Motor 2 | 0.0–30.0% | * | Adv |

* Based upon inverter models

Option Parameters

- F1 Pulse Generator Option Set-up
- F2 Analog Input 14 Set-up
- F3 Digital Input Option Set-up
- F4 Analog Output Option Set-up
- F5 Digital Output 2 Set-up
- F6 Digital Output 8 Set-up
- F7 PG Output 36 Set-up
- F9 CP-916 Setup

Encoder (PG) Option Set-up

| Parmtr Code | Display | Function | Range | Initial Value | Access Level |
|--------------------|------------------|---|--------------------|----------------------|---------------------|
| F1-01 | PG Pulses/Rev | Sets encoder Pulses/Rev | 0–60000 pulses/rev | 1024 | Adv |
| F1-02 | PG Fdbk Loss Sel | Selects stopping method or alarm output when PG line break is detected. | | 1 | Adv |
| | 0 Ramp to Stop | Decels to stop | | | |
| | 1 Coast to Stop | Immediate stop | | | |
| | 2 Fast-Stop* | Decel by B5-08 | | | |
| | 3 Alarm Only | Displayed on keypad only | | | |
| F1-03 | PG Overspeed Sel | Selects stopping method or alarm output when motor overspeed is detected. | | 1 | Adv |
| | 0 Ramp to Stop | Decels to stop | | | |
| | 1 Coast to Stop | Immediate stop | | | |
| | 2 Fast-Stop* | Decel by B5-08 | | | |
| | 3 Alarm Only | Displayed on keypad only | | | |
| F1-04 | PG Deviation Sel | Selects stopping method when PG deviation is detected. | | 1 | Adv |
| | 0 Ramp to Stop | Decels to stop | | | |
| | 1 Coast to Stop | Immediate stop | | | |
| | 2 Fast-Stop* | Decel by B5-08 | | | |
| | 3 Alarm Only | Displayed on keypad only | | | |
| F1-05 | PG Rotation Sel | Selects PG rotation | | 0 | Adv |
| | 0 Fwd = C.C.W. | | | | |
| | 1 Fwd = C.W. | | | | |
| F1-06 | PG Output Ratio | PG division rate (pulse output) | 1-132 | 1 | Adv |

NOTE: *Fast-stop is selected, the stopping time is set by B5-08 (Fault stop time)

| Parmtr Code | Display | Function | Range | Initial Value | Access Level |
|--------------------|-------------------|--|--------------|----------------------|---------------------|
| F1-07 | PG Ramp PI/I Sel | Enable/Disable speed control (ASR) integral operation during acceleration/deceleration (see D4 sections) | | 0 | Adv |
| | <i>0 Disabled</i> | | | | |
| | <i>1 Enabled</i> | | | | |
| F1-08 | PG Overspd Level | Motor overspeed detection level. | 0–120% | 115 | Adv |
| F1-09 | PG Overspd Time | Motor overspeed detection time. | 0–2.0 sec | 0.0 | Adv |
| F1-10 | PG Deviate Level | Excessive speed deviation level. | 0–50% | 10 | Adv |
| F1-11 | PG Deviate Time | Excessive speed deviation time. | 0–10.0 sec | 0.3 | Adv |
| F1-12 | SFS Deviate | Soft starter deviation level | 0-400 Hz | 120.0 | Adv |
| F1-13 | PG # Gear Teeth1 | Number of gear teeth—Option 1. | 0–1000 | 0 | Adv |
| F1-14 | PG# Gear Teeth2 | Number of gear teeth—Option 2. | 0–1000 | 0 | Adv |
| F1-15 | PGO Detect Time | Open encoder circuit | 0.00-10.00 | 0.50 | Adv |
| F1-16 | Pulse PPR | Indicates how many pulses the drive can expect at the multi-function input per revolution of the motor. | 1-1024 PPR | 1 | Adv |
| F1-17 | Pulse Enable Spd | Encoder backup function is enabled when the speed reference from the drive is at or below the parameter setting. | 0.0-150.0 Hz | 10.0 Hz | Adv |
| F1-18 | MFI Fault Buffer | Indicates how many consecutive times the PGO2 fault condition must exist before a fault is posted. Without this parameter, under normal stopping conditions the multi-function input may turn on just as the drive is stopping, and the encoder counts may not change enough to prevent a fault from being posted. | 0-20 | 3 | Adv |

AI-14 Set-up

Sets CH1 to CH3 input functions when AI-14B option is connected (2CN).

When the 3CH individual input is used, parameter B3-01 is automatically set to “1” (frequency reference from control circuit terminal). The option/inverter reference selection, which is selected by a multi-function contact input (H1-XX= “1E”), is disabled when using the AI-14B option.

| Parmtr Code | Display | Function | Range | Initial Value | Access Level |
|--------------------|-------------------------|---|--------------|----------------------|---------------------|
| F2-01 | AI-14 Input Sel | Determines whether the 3-channel input selection is individual or additional. | | 0 | Adv |
| | <i>0 3ch Individual</i> | | | | |
| | <i>1 3ch Additional</i> | | | | |

Sets CH1 to CH3 input functions when AI-14B option is connected

| Setting | Function | CH1 (TC1 to TC4) | CH2 (TC2 to TC4) | CH3 (TC3 to TC4) |
|----------------|--|---|----------------------------------|----------------------------------|
| 0 | 3-channel individual input (factory default) | Substitute for terminals 13 & 17 | Substitute for terminals 14 & 17 | Substitute for terminals 16 & 17 |
| 1 | 3-channel additional input | Sum of CH1 to CH3 input values is used as the frequency reference value | | |

When the 3CH individual input is used, parameter B3-01 is automatically set to “1” (frequency reference from control circuit terminal). The option/inverter reference selection, which is selected by a multi-function contact input (H1-XX= “1E”), is disabled when using the AI-14B option.

Digital Input Option Set-up

Selects the setting of the frequency reference input from the DI-08 and DI-16H option cards.

NOTE: B3-01 must be set to 3-option PCB when using these cards.

| Parmtr Code | Display | Function | Range | Initial Value | Access Level |
|--------------------|---------------------------|---|--------------|----------------------|---------------------|
| F3-01 | DI Option Setup | Selects the setting mode of the reference input from the DI-08 and DI-16H options | 0-7 | 0 | Adv |
| | 0 <i>BCD 1%</i> | BCD 1% unit | | | |
| | 1 <i>BCD 0.1%</i> | BCD 0.1% unit | | | |
| | 2 <i>BCD 0.01%</i> | BCD 0.01% unit | | | |
| | 3 <i>BCD 1Hz</i> | BCD 1Hz unit | | | |
| | 4 <i>BCD 0.1Hz</i> | BCD 0.1Hz unit | | | |
| | 5 <i>BCD 0.01Hz</i> | BCD 0.01Hz unit | | | |
| | 6 <i>BCD (SDG) 0.01Hz</i> | Binary | | | |
| | | DI-08: | 255/100% | | |
| | | DI-16H, 12 bit selection: | 4096/100% | | |
| | | DI-16H, 16 bit selection: | 3000/100% | | |
| | 7 <i>Binary</i> | Set value is displayed in decimal notation | | | |

Analog Output Option Set-up

Selects the analog output monitors for channel 1 and 2 if AO-08 and AO-12 optional card is connected to 3CN.

| Parmtr Code | Display | Function | Range | Initial Value | Access Level |
|--------------------|----------------------------|--|--------------|----------------------|---------------------|
| F4-01 | AO Ch1 Select | Analog output option Channel 1 selection | 1–35 | 2 | Adv |
| | 1 <i>Frequency Ref</i> | | | | |
| | 2 <i>Output Freq</i> | | | | |
| | 3 <i>Output Current</i> | | | | |
| | 5 <i>Motor Speed</i> | | | | |
| | 6 <i>Output Voltage</i> | | | | |
| | 7 <i>DC Bus Voltage</i> | | | | |
| | 8 <i>Output kWatts</i> | | | | |
| | 9 <i>Torque Reference</i> | | | | |
| | 15 <i>Term 13 Level</i> | | | | |
| | 16 <i>Term 14 Level</i> | | | | |
| | 17 <i>Term 16 Level</i> | | | | |
| | 18 <i>Mot SEC Current</i> | | | | |
| | 19 <i>Mot EXC Current</i> | | | | |
| | 20 <i>SFS Output</i> | | | | |
| | 21 <i>ASR Input</i> | | | | |
| | 22 <i>ASR Output</i> | | | | |
| | 23 <i>Speed Deviation</i> | | | | |
| | 24 <i>PID Feedback</i> | | | | |
| | 26 <i>Voltage Ref (Vq)</i> | | | | |
| | 27 <i>Voltage Ref (Vd)</i> | | | | |
| | 29 <i>Load Weight</i> | | | | |
| | 31 <i>Not used</i> | | | | |
| | 32 <i>ACR (q) Output</i> | | | | |
| | 33 <i>ACR (d) Output</i> | | | | |
| | 35 <i>Friction Torq</i> | | | | |
| F4-02 | AO Ch1 Gain | Analog output Channel 1 multiplier | 0–2.50 | 1.00 | Adv |
| F4-03 | AO Ch2 Select | Analog output option Channel 2 selection (Same as F4-01) | 1–35 | 3 | Adv |
| F4-04 | AO Ch2 Gain | Analog output Channel 2 multiplier | 0–2.50 | 0.50 | Adv |

DO-02 Digital Output Set-up

Selects the multi-function output settings for channels 1 and 2 of the DO-02 option card.

| Parmtr Code | Display | Function | Range | Initial Value | Access Level |
|--------------------|------------------|--|--------------|----------------------|---------------------|
| F5-01 | DO-02 Ch1 Select | Determines the DO-02 digital output Channel 1 selection (See H2-01) | 0–FF | 0 | Adv |
| F5-02 | DO-02 Ch2 Select | Determines the DO-02 digital output Channel 2 selection (See H2-01) | 0–FF | 1 | Adv |

DO-08 Digital Output Set-up

Selects the multi-function output settings for the DO-08 option card.

| Parmtr Code | Display | Function | Range | Initial Value | Access Level |
|--------------------|------------------|--|--------------|----------------------|---------------------|
| F6-01 | DO-08 Selection | Selects Multi-Function Output Selections for the DO-08 option. | | 0 | Adv |
| | 0 8ch Individual | | | | |
| | 1 Binary Output | | | | |
| | 2 Srl Com Output | | | | |

Selects the multi-function output selections for the DO-08 option.

Table 5.8:

| Setting | Terminal No. | Description |
|---|---------------------|-----------------------------|
| 0 8-Channel individual (factory Default) | TD5/TD11 | Overcurrent (SC, OC, GF) |
| | TD6/TD11 | Overvoltage (OV) |
| | TD7/TD11 | Inverter overload (OL2) |
| | TD8/TD11 | Fuse blown (FU) |
| | TD9/TD11 | Not used |
| | TD10/TD11 | Inverter overheat (OH) |
| | TD1/TD2 | During zero-speed detection |
| | TD3/TD4 | During speed agree |
| 1 binary output | TD5/TD11 | |
| | TD6/TD11 | Binary output* |
| | TD7/TD11 | |
| | TD8/TD11 | |
| | TD9/TD11 | During zero-speed detection |
| | TD10/TD11 | During speed agree |
| | TD1/TD2 | During run |
| | TD3/TD4 | Minor fault |

* When F6-01 is set to binary output (setting = "1"), use the table on the following page to read the DO-08 output.

Table 5.9

| TD8/TD11 (bit 3) | TD7/TD11 (bit 2) | TD6/TD11 (bit 1) | TD5/TD11 (bit 0) | Description |
|-----------------------------|-----------------------------|-----------------------------|-----------------------------|---------------------------------|
| 0 | 0 | 0 | 0 | No Fault |
| 0 | 0 | 0 | 1 | Overcurrent (SC, OC, GF) |
| 0 | 0 | 1 | 0 | Overvoltage (OV) |
| 0 | 0 | 1 | 1 | Inverter overload (OL2) |
| 0 | 1 | 0 | 0 | Inverter overheat (OH) |
| 0 | 1 | 0 | 1 | Overspeed (OS) |
| 0 | 1 | 1 | 0 | Fuse blown (FU) |
| 0 | 1 | 1 | 1 | Not used |
| 1 | 0 | 0 | 0 | External fault (EF3~EF8) |
| 1 | 0 | 0 | 1 | Controller fault |
| 1 | 0 | 1 | 0 | Motor overload (OL1) |
| 1 | 0 | 1 | 1 | Not used |
| 1 | 1 | 0 | 0 | Power loss (UV1, UV2, UV3) |
| 1 | 1 | 0 | 1 | Excessive speed deviation (DEV) |
| 1 | 1 | 1 | 0 | PG disconnection (PGO) |
| 1 | 1 | 1 | 1 | Not used |

PO-36F Set-up

The PO-36F option card outputs pulse signals that correspond to the inverters output frequency.

| Parmtr Code | Display | Function | Range | Initial Value | Access Level |
|------------------------|------------------|--|--------------|--------------------------|-------------------------|
| F7-01 | PO-36F Selection | Sets the number of pulse signals to be output from the PO-36F option | | 1 | Adv |
| | 0 | 1 X Output Freq | | | |
| | 1 | 6 X Output Freq | | | |
| | 2 | 10 X Output Freq | | | |
| | 3 | 12 X Output Freq | | | |
| | 4 | 36 X Output Freq | | | |

Dual Port Ram

Settings for DP-RAM option cards.

| Parmtr Code | Display | Function | Range | Initial Value | Access Level |
|--------------------|---|--------------------------------------|--------------|----------------------|---------------------|
| F9-01 | EFO Selection <i>0 Normally Open</i> <i>1 Normally Closed</i> | Option External Fault | 0,1 | 0 | Adv |
| F9-02 | EFO Detection <i>0 Always Detected</i> <i>1 Only During Run</i> | Option External Fault | 0,1 | 0 | Adv |
| F9-03 | EFO Action <i>0 Ramp to Stop</i> <i>1 Coast to Stop</i> <i>2 Fast Stop</i> <i>3 Alarm Only</i> | Option External Fault | 0-3 | 1 | Adv |
| F9-04 | Trace Sample Time | | 0-60,000 | 0 | Adv |
| F9-05 | Torq Ref/Lmt Sel <i>0 Disabled</i> <i>1 Enabled</i> | Torque Reference Limit Selection | 0, 1 | 0 | Factory |
| F9-06 | BUS Fault Sel <i>0 Ramp to Stop</i> <i>1 Coast to Stop</i> <i>2 Fast Stop</i> <i>3 Alarm Only</i> | DP-RAM Communication Fault Selection | 0-3 | 1 | Adv |

Terminal Parameters

- H1 Digital Inputs
- H2 Digital Outputs
- H3 Analog Inputs
- H4 Analog Outputs
- H5 Serial Communication Set-up

Digital Inputs

The IMPULSE•VG+ Series 2 has six multi-function contact inputs for the set-up of numerous functions. The following table lists the function selections for the multi-function contact inputs (terminals 3 to 8) and indicates the control modes during which each function can be enabled. An OPEO3 error will occur if a function is programmed in more than one terminal at the same time.

| Parmtr Code | Display | Function | Ref Page Number | Range | Initial Value | Access Level |
|--------------------|--------------------------------------|--|------------------------|--------------|----------------------|---------------------|
| H1-01* | Terminal 3 Sel <i>(parameter)</i> | Selects the multi-function inputs. | | | 0 | Adv |
| H1-02* | Terminal 4 Sel <i>(parameter)</i> | Same as H1-01 | | 0-4F | 1 | Adv |
| H1-03* | Terminal 5 Sel <i>(parameter)</i> | Same as H1-01 | | 0-4F | 7 | Adv |
| H1-04* | Terminal 6 Sel <i>(parameter)</i> | Same as H1-01 | | 0-4F | 9 | Adv |
| H1-05* | Terminal 7 Sel <i>(parameter)</i> | Same as H1-01 | | 0-4F | 24 | Adv |
| H1-06* | Terminal 8 Sel <i>(parameter)</i> | Same as H1-01 | | 0-4F | E | Adv |
| | 0 <i>Multi-Step Ref 2</i> | <i>Multi-Step Speed 2.</i> | 5-3 | | | |
| | 1 <i>Multi-Step Ref 3</i> | <i>Multi-Step Speed 3.</i> | 5-3 | | | |
| | 2 <i>Multi-Step Ref 4</i> | <i>Multi-Step Speed 4.</i> | 5-3 | | | |
| | 3 <i>Multi-Step Ref 5</i> | <i>Multi-Step Speed 5.</i> | 5-3 | | | |
| | 4 <i>Speed Hold 2</i> | <i>Hold function (2nd step of Three-Step Infinitely Variable).</i> | 4-10 | | | |
| | 5 <i>Accel Command</i> | <i>Acceleration function (2nd step of Two-Step Infinitely Variable or 3rd step of Three-Step Infinitely Variable).</i> | 4-10 | | | |

| | | | |
|----|--------------------------------|--|------|
| 6 | Upper Lmt 1 N/O | Upper Limit–SLOW DOWN; Normally Open | 5-25 |
| 7 | Upper Lmt 2 N/O | Upper Limit–STOP; Normally Open | 5-25 |
| 8 | Lower Lmt 1 N/O | Lower Limit–SLOW DOWN; Normally Open | 5-25 |
| 9 | Lower Lmt 2 N/O | Lower Limit–STOP; Normally Open | 5-25 |
| A | Upper Lmt 1 N/C | Upper Limit–SLOW DOWN; Normally Closed | 5-25 |
| B | Upper Lmt 2 N/C | Upper Limit–STOP; Normally Closed | 5-25 |
| C | Lower Lmt 1 N/C | Lower Limit–SLOW DOWN; Normally Closed | 5-25 |
| D | Lower Limit 2 N/C | Lower Limit–STOP; Normally Closed | 5-25 |
| E | M-Speed Gain 1 | Micro-Positioning Control Multiplier 1 | 5-24 |
| F | Not used | No function | n/a |
| 10 | M-Speed Gain 2 | Micro-Positioning Control Multiplier 2 | 5-24 |
| 11 | Load Float | Load Float Hold; when input during run, Load Float will remain on. | n/a |
| 12 | M-Speed Gain 1 & Load Float | Combination of Micro- positioning Control and Load Float | n/a |
| 13 | Ultra/Swift Lift | Ultra-Lift enable | 5-30 |
| 14 | Torque Lmt Acc/Dec | Torque Limit Acceleration/ Deceleration | 5-18 |
| 15 | Alt T-Lim Gain | Alternate Torque Limit Multiplier | 5-32 |
| 16 | Forward Jog | Jog Control FORWARD command | 5-3 |
| 17 | Reverse Jog | Jog Control REVERSE command | 5-3 |
| 18 | Forward Inch | Inch Control | 5-55 |
| 19 | Reverse Inch | Inch Control | 5-55 |
| 1A | Inch Repeat | Inch Control | 5-55 |
| 1B | Multi-Acc/Dec 1 | Acceleration and Deceleration Changeover Time | 5-15 |
| 1C | Reference SW | Analog/Digital Reference Changeover: B1-10=1. Open=Analog Closed=Digital Reference from B1-01 Only | 5-13 |
| 1D | Term 13/16 Switch | Terminal 13/16 Switch | 5-91 |
| 1F | Program Lockout | Program Lockout | n/a |
| 24 | External Fault | See “External Fault response selection” | 5-89 |
| 30 | Term 13/14 Switch | Terminal 13/14 Switch | 5-90 |
| 31 | Fault Reset N/O | Fault Reset; Normally Open | n/a |

| | | | |
|-------|---------------------------|--|------|
| 32 | <i>Fault Reset N/C</i> | <i>Fault Reset; Normally Closed</i> | n/a |
| 34 | <i>Trim Ctl Increase</i> | <i>Trim Control Increase</i> | 5-14 |
| 35 | <i>Trim Ctl Decrease</i> | <i>Trim Control Decrease</i> | 5-14 |
| 36 | <i>Brake Ans Back</i> | <i>Brake Answer-Back</i> | 5-34 |
| 37 | <i>Ext BaseBlk N/O</i> | <i>Immediate Stop at STOP Command; Normally Open</i> | n/a |
| 38 | <i>Ext BaseBlk N/C</i> | <i>Immediate Stop at STOP Command; Normally Closed</i> | n/a |
| 39 | <i>Spd/Trq Ctl Chng</i> | <i>Speed- and Torque-Control Changeover</i> | n/a |
| 3A | <i>Zero Servo Cmd</i> | <i>Initiates Zero Servo Sequence</i> | n/a |
| 3C | <i>ASR Intgrl Reset</i> | <i>Automatic Speed Regulator Integral Reset.</i> | n/a |
| 3D | <i>Motor Select</i> | <i>Motor 2 enabled</i> | 5-72 |
| 3E | <i>ASR Gain Switch</i> | <i>Automatic Speed Regulator Multiplier Changeover</i> | n/a |
| 40 | <i>**BE6 Up Speed Lmt</i> | <i>Limits Speed to Frequency Set in C8-17</i> | n/a |
| 41 | <i>DCInj Activate</i> | <i>DC Injection Brake</i> | n/a |
| 43 | <i>Alt S-Ref UpLmt</i> | <i>Alternate Upper Limit Frequency Reference</i> | 5-5 |
| 44 | <i>Weight Measure</i> | <i>Weight Measurement Command</i> | n/a |
| 45 | <i>Serial/Inv Switch</i> | <i>Serial/Inverter Run and Speed Reference Changeover</i> | n/a |
| 46 | <i>Load Float Ext</i> | <i>Extend Load Float Time</i> | n/a |
| 47 | <i>M-Spd Gn1 and LF-E</i> | <i>Micro-Speed Gain 1 and Load Float extent.</i> | n/a |
| ***4A | <i>Timer Function</i> | <i>Closed: enable ON-Delay/OFF delay timer</i> | 5-54 |
| ***4B | <i>Option/INV Sel</i> | <i>Option/Inverter speed reference changeover (option speed reference at closed)</i> | 5-83 |
| ***4C | <i>Dwell Enable</i> | <i>Closed: Enables dwell function</i> | 5-63 |
| 4F | <i>Pulse Monitor</i> | <i>Enables the encoder backup using a pulse train input. (Setup using F1-16–F1-18)</i> | 5-74 |

* Initial value is determined by X-Press Programming (Table 4.1 to 4.6).

**Available only in software versions 14910-14912.

***Available only in software versions 14912.5 and greater.

Digital Outputs

The IMPULSE•VG+ Series 2 has three multi-function control outputs for indicating various conditions. The following table lists the function selections for the multi-function contact output (terminals 9, 25, and 26), and indicates the control modes during which each function can be enabled. Note that Terminals 25 and 26 are Terminals 1 and 2 respectively on G5OUT option card.

| Parmtr Code | Display | Function | Reference | | Initial Value | Access Level |
|----------------|---------------------|--|----------------|-------|------------------|-----------------|
| | | | Page Number | Range | | |
| H2-01 | Terminal 9 Sel | Assigns one of the following 48 multi-function digital output parameters to Terminal 9, 25, or 26. | --- | 0–40 | 0 | Adv |
| H2-02 | Terminal 25 Sel | Terminal 1 on the G5OUT Option Card | --- | 0–40 | 0 | Adv |
| H2-03 | Terminal 26 Sel | Terminal 2 on the G5OUT Option Card | --- | 0–40 | 7F | Adv |
| | 0 Brake Output | Closed when voltage or frequency is output | n/a | | | |
| | 1 Zero Speed | Closed when below B2-02 or D1-01 | n/a | | | |
| | 2 Fref/Fout Agree 1 | Output when Frequency Reference and Frequency Output agree | 5-98 | | | |
| | 3 Fref/Set Agree 1 | Output when Output Frequency Reference equals L4-01. | 5-98 | | | |
| | 4 Freq Detect 1 | Closed when output frequency is < L4-01. | 5-98 | | | |
| | 5 Freq Detect 2 | Closed when output frequency is > L4-01. | 5-98 | | | |
| | 6 Inverter Ready | Closed when an inverter is not in a fault state | n/a | | | |
| | 7 DC Bus Undervolt | Closed when DC Bus voltage drops below UV trip point. | n/a | | | |
| | 8 BaseBlk 1 | Closed when the inverter is not outputting voltage. | n/a | | | |
| | 9 Option Reference | Closed when the frequency reference is input from the digital operator (02-01). | 5-108 | | | |
| | A Remote Operation | Closed when the RUN command is input from the digital operator. | 5-108 | | | |
| | B Trq Det 1 N.O. | Output when torque > L6-02 | 5-100 | | | |
| | C Loss of Ref | Closed when inverter has detected a loss of frequency reference | 5-99 | | | |
| | D DB Overheat | Closed when inverter displays "RH" or "RR" fault. | n/a | | | |
| | E Fault | Closed during a major fault. | 6-3 | | | |
| | F Not Used | No function | | | | |
| | 10 Minor Fault | Closed during minor fault or alarm. | 6-3 | | | |

| Parmtr Code | Display | Function | Reference | | Initial Value | Access Level |
|----------------|-------------------|---|----------------|-------|------------------|-----------------|
| | | | Page Number | Range | | |
| 11 | Reset Cmd Active | Closed when a reset command is present on the terminals | n/a | | | |
| 12 | Timer Output | Timer function output | 5-54 | | | |
| 13 | Fref/Fout Agree 2 | Closed when output frequency = frequency reference | 5-97 | | | |
| 14 | Fref/Set Agree 2 | Closed when output frequency = L4-03 | 5-97 | | | |
| 15 | Freq Detect 3 | Closed when output frequency is \leq L4-03 | 5-98 | | | |
| 16 | Freq Detect 4 | Closed when output frequency \geq L4-03 | 5-98 | | | |
| 17 | Trq Det 1 N.C. | Open when torque > L6-02 | 5-99 | | | |
| 18 | Trq Det 2 N.O. | Closed when torque > L6-05 | 5-99 | | | |
| 19 | Trq Det 2 N.C. | Open when torque > L6-05 | 5-99 | | | |
| 1A | Forward Dir | Closed when running FWD/UP | n/a | | | |
| 1B | Reverse Dir | Closed when running REV/DOWN | n/a | | | |
| 1C | Speed Increasing | Closed when speed is increasing | n/a | | | |
| 1D | BaseBlk 2 (N.C.) | Open when inverter is not outputting voltage. | n/a | | | |
| 1E | Motor A/B Change | Closed when motor changeover is input to terminals | n/a | | | |
| 1F | Regenerating | Regenerating | n/a | | | |
| 20 | Auto-Rst Enabled | Auto-Reset Enabled | 5-103 | | | |
| 21 | Overload (OL1) | OL1 Overload fault code | n/a | | | |
| 22 | OH Prealarm | Closed when "OH" is displayed on keypad | n/a | | | |
| 30 | Current Trq LIM | Current Torque Limit | n/a | | | |
| 31 | Speed Limit | Speed Limit | n/a | | | |
| 33 | Zero Servo End | Zero-Servo End | n/a | | | |
| 34 | During RUN 2 | During Run 2 - ON: Frequency output, OFF: Base block, DC injection braking, initial excitation | n/a | | | |
| 35 | Load Check Fault | Load Check fault output | 5-28 | | | |
| 36 | Slack Cable Det | Slack Cable Detection output | 5-52 | | | |
| 37 | Upper Lmt input | Closed when Upper Limit-SLOW DOWN or Upper Limit STOP is input | 5-25 | | | |
| 38 | Lower Lmt input | Closed when Lower Limit-SLOW DOWN or Lower Limit STOP is input | 5-25 | | | |
| 39 | Up/Low Lmt input | Closed when Upper Limit-SLOW DOWN or Upper Limit STOP or Lower Limit-SLOW DOWN or Lower Limit STOP is input | 5-25 | | | |

| Parmtr Code | Display | Function | Reference Page Number | Range | Initial Value | Access Level |
|------------------------|---------------------------------|------------------------------------|--------------------------------------|--------------|--------------------------|-------------------------|
| | <i>3B During RUN 1</i> | <i>Output for RUN 1</i> | n/a | | | |
| | <i>40 ~ FF Fault Annunciate</i> | <i>Closed on specified faults.</i> | 5-87 | | | |

Digital Outputs—Fault Annunciate (H2-01~03=40)

Digital Outputs—Fault Annunciate enables you to assign a set of six fault outputs to Terminals 1 and/or Terminal 2 on the G5out card. In addition, you can select whether each fault output is enabled.

NOTE: Terminal 9 can also be used for Digital Outputs—Fault Annunciate; however, it is normally assigned to a brake output.

Before you start to program this feature, you may find it convenient to first photocopy the “Binary-to-Hexadecimal Conversion Worksheet” in this section. By being able to write in the worksheet’s boxes, you will find it easier to program the feature.

Programming **Digital Outputs—Fault Annunciate** requires that you determine two 4-digit binary numbers and then convert these numbers to two 1-digit hexadecimal numbers. You enter the hexadecimal numbers when you program the drive.

To program **Digital Outputs—Fault Annunciate** (assuming you are in **Programming Mode**):

1. Press the **UP** button until

| |
|---------------------|
| Group H Terminal |
|---------------------|

 appears.
2. Press the **DATA/ENTER** button.

| |
|-------------------------------|
| Function H1 Digital Inputs |
|-------------------------------|

 appears.
3. Press the **UP** button.

| |
|--------------------------------|
| Function H2 Digital Outputs |
|--------------------------------|

 appears.
4. Determine the output terminal to which you want **Fault Annunciate** assigned; Terminal 9, 25, or 26.
5. Press the **DATA/ENTER** button.

| |
|------------------------------|
| Terminal 9 Sel XXXXXXXXXX |
|------------------------------|

 appears. If you want Terminal 25 or 26, press the **UP** button until it appears. Assume you are using Terminal 9.
6. Press the **DATA/ENTER** button.

| |
|---------------------------|
| H2-01=X**** XXXXXXXXXX |
|---------------------------|

 appears.
7. Press the **UP** or **DOWN** button until

| |
|------------------------------|
| H2-01=40 Fault Annunciate |
|------------------------------|

 appears.
8. Press the **DATA/ENTER** button.

| |
|------------------------|
| Fault Data Input 00 |
|------------------------|

 appears.

9. From the following worksheet, select one of three fault output sets. (Each row is a set.)

Enter the one-zero combination that corresponds to the set (row) that you selected.

For example, if you selected Set 2, you would enter “1 0” in the first two columns from the left, which would represent the first two digits of the first binary number that you would convert later.

Table 5.10: Binary-to-Hexadecimal Conversion Worksheet

| | First digit from the left | | | | Second digit from the left | | | |
|-------|---------------------------|--------|--------|--------|----------------------------|--------|--------|--------|
| | 1 or 0 | 1 or 0 | 1 or 0 | 1 or 0 | 1 or 0 | 1 or 0 | 1 or 0 | 1 or 0 |
| Set 1 | 1 | 1 | BE7 | BE5 | BE4 | BE0 | OL2 | OL1 |
| Set 2 | 1 | 0 | OS | DEV | LL1 | LL2 | UL1 | UL2 |
| Set 3 | 0 | 1 | BE6 | BE5 | BE4 | BE3 | BE2 | BE1 |

10. Determine which fault outputs should be enabled. To enable a fault output, enter 1 in the box above the fault output; otherwise, enter 0. Do this for each fault output in the set.

For example, if Set 2 is selected and LL1 and UL1=1, “1 0 0 0” and “1 0 1 0 “ would be the two 4-digit binary numbers.

11. Using the conversion table below, determine the 1-digit hexadecimal number for both 4-digit binary numbers.

Table 5.11

| Binary Number | Hexadecimal Number |
|---------------|--------------------|
| 0000 | 0 |
| 0001 | 1 |
| 0010 | 2 |
| 0011 | 3 |
| 0100 | 4 |
| 0101 | 5 |
| 0110 | 6 |
| 0111 | 7 |
| 1000 | 8 |
| 1001 | 9 |
| 1010 | A |
| 1011 | B |
| 1100 | C |
| 1101 | D |
| 1110 | E |
| 1111 | F |

Continuing with the example, “1 0 0 0” and “1 0 1 0 “ converts to “8A.”

12. Press the **UP** or **DOWN** button until the appropriate hexadecimal number appears for XX on

| |
|------------------------|
| Fault Data Input XX |
|------------------------|

External Fault Response Selection

It is sometimes desirable to have at least one external fault input to the drive. To properly program a multi-function input (H1-01 to H1-06) for this purpose an external fault response must be selected. The table below shows the possible selections for an external fault response.

Table 5.12

| External Fault Selection | | | | | | | | MFI Setting Result |
|--------------------------|------|------------------|------------|-----------------------|---------------|------------|------------|--------------------|
| Input Level Selection | | Detection Method | | External Fault Action | | | | |
| N.O. | N.C. | Always | During Run | Ramp to Stop | Coast to Stop | Fast-stop* | Alarm Only | |
| √ | | √ | | √ | | | | 20 |
| √ | | √ | | | √ | | | 24 |
| √ | | √ | | | | √ | | 28 |
| √ | | √ | | | | | √ | 2C |
| √ | | | √ | √ | | | | 22 |
| √ | | | √ | | √ | | | 26 |
| √ | | | √ | | | √ | | 2A |
| √ | | | √ | | | | √ | 2E |
| | √ | √ | | √ | | | | 21 |
| | √ | √ | | | √ | | | 25 |
| | √ | √ | | | | √ | | 29 |
| | √ | √ | | | | | √ | 2D |
| | √ | | √ | √ | | | | 23 |
| | √ | | √ | | √ | | | 27 |
| | √ | | √ | | | √ | | 2B |
| | √ | | √ | | | | √ | 2F |

* Uses B5-08 timer

NOTE: (1) N.O. = normally open contact; N.C. = normally closed contact
 (2) Setting 24 is the factory default

Analog Inputs

The IMPULSE•VG+ Series 2 has three analog inputs (two multi-function and one reference) for the external input of numerous references and limits.

* Initial value is determined by X-Press Programming (Table 4-1 to 4-12).

| Parmtr Code | Display | Function | Range | Initial Value | Access Level |
|--------------------|--|--|----------------|----------------------|---------------------|
| H3-01* | Term 13 Signal 0 OVDC to 10VDC 1 -10VDC to +10VDC | Voltage for Terminal 13 analog input signal | 0-1 | 0 | Adv |
| H3-02 | Terminal 13 Gain | Gain multiplier for Terminal 13 analog input signal | 0.0-1000.0% | 100 | |
| H3-03 | Terminal 13 Bias | Bias multiplier for Terminal 13 analog input signal | -100.0–100.0% | 0 | |
| H3-04 | Term 16 Signal 0 0VDC to 10VDC 1 -10VDC to +10VDC | Voltage for Terminal 16 analog input signal | 0-1 | 0 | |
| H3-05 | Terminal 16 Sel 0 Aux Reference 1 Frequency Gain 2 Frequency Bias 5 Acc/Dec Change 7 Overtorque Level 9 Ref Lower Limit A Jump Frequency B PID Feedback 10 Forward Torque Limit 11 Reverse Torque Limit 12 Regen Torque Limit 13 Torque Reference 14 Torque Compensation 15 FWD/REV Torque Limit 16 Term 16 SW Ref 1F Not Used | Assigns one of the following function analog input parameters to Terminal 16 <i>Auxiliary Reference</i> <i>Frequency Gain</i> <i>Frequency Reference Bias</i> <i>Acceleration/Deceleration Changeover</i> <i>Overtorque Detection Level</i> <i>Speed Reference Lower Limit</i> <i>Jump Frequency</i> <i>Proportional, Integral, and Derivative (PID) Control Feedback</i> <i>Not Used</i> | | 0 | Adv |
| H3-06 | Terminal 16 Gain | Gain multiplier for Terminal 16 analog input signal | 0000.0–1000.0% | 100.0 | Adv |
| H3-07 | Terminal 16 Bias | Bias multiplier for Terminal 16 analog input signal | -100.0–100.0% | 0.0 | Adv |

| Parmtr Code | Display | Function | Range | Initial Value | Access Level |
|--------------------|---|---|----------------|----------------------|---------------------|
| H3-08 | Term 14 Signal | Terminal 14 Signal Level Selection | 0-2 | 2 | Adv |
| | 0 0 to +10VDC *(Call Electromotive Systems first to modify control board). | | | | |
| | 1 -10 to +10VDC *(Call Electromotive Systems first to modify control board). | | | | |
| | 2 4 to 20mA | | | | |
| H3-09 | Terminal 14 Sel | Assigns one of the following function analog input parameters to Terminal 14. | | 1F | Adv |
| | 0 Aux Reference | Auxiliary Reference | | | |
| | 1 Frequency Gain | Frequency Gain | | | |
| | 2 Frequency Bias | Frequency Reference Bias | | | |
| | 5 Acc/Dec Change | Acceleration/Deceleration Changeover | | | |
| | 7 Overtorque Level | Overtorque Detection Level | | | |
| | 9 Ref Lower Limit | Speed Reference Lower Limit | | | |
| | A Jump Frequency | Jump Frequency | | | |
| | B PID Feedback | Proportional, Integral, and Derivative (PID) Control Feedback | | | |
| | 10 Forward Torque Limit | | | | |
| | 11 Reverse Torque Limit | | | | |
| | 12 Regen Torque Limit | | | | |
| | 13 Torque Reference | | | | |
| | 14 Torque Compensation | | | | |
| | 15 FWD/REV torque limit | | | | |
| | 1F Not Used | Frequency Reference | | | |
| H3-10 | Terminal 14 Gain | Gain multiplier for terminal 14 analog input signal | 0000.0–1000.0% | 100.0 | Adv |
| H3-11 | Terminal 14 Bias | Bias multiplier for terminal 14 analog input signal | -100.0–100.0% | 0.0 | Adv |
| H3-12 | Filter Avg Time | Analog input filter average time | 0.00–2.00sec | 0.00 | Adv |

* Damage may otherwise result.

** Time is doubled if a Bi-Polar analog input is used. (±10V)

Analog Outputs

The IMPULSE•VG+ Series 2 has two analog outputs for the external monitoring of drive conditions.

| Parmtr Code | Display | Function | Range | Initial Value | Access Level |
|--------------------|----------------------------|---|--------------|----------------------|---------------------|
| H4-01 | Terminal 21 Sel | Assigns one of the following function analog output parameters to Terminal 21 | | 2 | Adv |
| | <i>1 Frequency Ref</i> | | | | |
| | <i>2 Output Freq</i> | | | | |
| | <i>3 Output Current</i> | | | | |
| | <i>5 Motor Speed</i> | | | | |
| | <i>6 Output Voltage</i> | | | | |
| | <i>7 DC Bus Voltage</i> | | | | |
| | <i>8 Output kWatts</i> | | | | |
| | <i>9 Torque Reference</i> | | | | |
| | <i>15 Term 13 Level</i> | | | | |
| | <i>16 Term 14 Level</i> | | | | |
| | <i>17 Term 16 Level</i> | | | | |
| | <i>18 Mot SEC Current</i> | | | | |
| | <i>19 Mot EXC Current</i> | | | | |
| | <i>20 SFS Output</i> | | | | |
| | <i>21 ASR Input</i> | | | | |
| | <i>22 ASR Output</i> | | | | |
| | <i>23 Speed Deviation</i> | | | | |
| | <i>24 PID Feedback</i> | | | | |
| | <i>26 Voltage Ref (Vq)</i> | | | | |
| | <i>27 Voltage Ref (Vd)</i> | | | | |
| | <i>29 Load Weight</i> | | | | |
| | <i>31 Not used</i> | | | | |
| | <i>32 ACR (q) Output</i> | | | | |
| | <i>33 ACR (d) Output</i> | | | | |
| | <i>35 Friction Torq</i> | | | | |
| H4-02 | Terminal 21 Gain | Gain multiplier for Terminal 21 analog output signal | 0.00–2.50 | 1.00 | Adv |
| H4-03 | Terminal 21 Bias | Bias multiplier for Terminal 21 analog output signal | -10.0–10.0 | 0.0 | Adv |
| H4-04 | Terminal 23 Sel | Assigns one of the above function analog output parameters to Terminal 23 | (See H4-01) | 3 | Adv |
| H4-05 | Terminal 23 Gain | Gain multiplier for Terminal 23 analog output signal | 0.00–2.50 | 1.00 | Adv |
| H4-06 | Terminal 23 Bias | Bias multiplier for Terminal 23 analog output signal | -10.0–10.0% | 0.0 | Adv |
| H4-07 | AO Level Select | | | 0 | Adv |
| | <i>0 0 to +10VDC</i> | | | | |
| | <i>1 -10 to +10VDC</i> | | | | |

Serial Communication Set-up

The IMPULSE•VG+ Series 2 uses communication port 6CN to communicate via MODBUS protocol.

| Parmtr Code | Display | Function | Range | Initial Value | Access Level |
|--------------------|--|--|--------------|----------------------|---------------------|
| H5-01 | Serial Com Adr | Serial communication address | 0–20 | 1F | Adv |
| H5-02 | Serial Baud Rate 0 1200 Baud 1 2400 Baud 2 4800 Baud 3 9600 Baud | Sets the baud rate | | 3 | Adv |
| H5-03 | Serial Com Sel 0 No parity 1 Even parity 2 Odd parity | Determines the parity | 0–2 | 0 | Adv |
| H5-04 | Serial Fault Set 0 Ramp to Stop 1 Coast to Stop 2 Fast-Stop 3 Alarm Only | Determines stopping method or fault at a serial fault occurrence | | 1 | Adv |
| H5-05 | Serial Flt Dtct 0 Disabled 1 Enabled | Determines whether Serial Fault Detection is enabled | | 1 | Adv |

NOTE: After changing any H5 parameter, power to the inverter must be cycled.

NOTE: After initial communication, if the inverter is not communicated with for 2 seconds, a communication fault will occur (CE Memobus ERR).

Protection Parameters

- L1 Motor Overload
- L3 Stall Prevention
- L4 Ref Detection
- L6 Torque Detection
- L8 Hardware Protection
- L9 Automatic Reset

Motor Overload

The IMPULSE•VG+ Series 2 protects against motor overload with a UL-recognized, built-in electronic thermal overload function.

The electronic thermal overload function estimates motor temperature, based on inverter output current, frequency and time to protect the motor from overheating. When the thermal overload fault is activated, an “OL1” trip occurs, shutting OFF the inverter output and preventing excessive overheating in the motor. As long as the inverter is powered up, it continues to calculate the motor temperature.

When operating with one inverter connected to one motor, an external thermal relay is not needed. When operating several motors with one inverter, use the internal thermal protection from the motor or install an external thermal overload relay on each motor. In this case, set parameter *L1-01* to “0.”

| Parmtr Code | Display | Function | Range | Initial Value | Access Level |
|--------------------|------------------------|---|--------------|----------------------|---------------------|
| L1-01 | MOL Fault Select | Enable/disable motor overload detection. | | 1 | Adv |
| | <i>0 Disabled</i> | | | | |
| | <i>1 Coast to Stop</i> | (Immediate stop) | | | |
| L1-02 | MOL Time Const | Time for OL1 fault when motor current is $\geq 150\%$ of the motor rated current. | 0.1–5.0 min | 1.0 | Adv |

Stall Prevention



CAUTION

This function automatically adjusts the output frequency, acceleration and/or deceleration rates in order to continue operation without tripping or “stalling” the inverter.

| Parmtr Code | Display | Function | Range | Initial Value | Access Level |
|-------------|-------------------|---|-------|---------------|--------------|
| L3-04 | StallP Decel Sel | Enable/Disable stall prevention during deceleration | | 0 | Adv |
| | 0 Disabled | See table below | | | |
| | 1 General Purpose | See table below | | | |

If deceleration times are set too short for load conditions, the inverter automatically extends the deceleration time according to the main circuit DC bus voltage level. When using an optional braking resistor for the IMPULSE•VG+ Series 2, set parameter *L3-04* to “0.” See the figure on next page.

Table 5.13

| Setting | Description |
|------------------------|--|
| 0 (Disabled) | Stall prevention during deceleration is disabled (factory default). An excessively short deceleration time will generate an overvoltage fault (OV), and the inverter will stop. |
| 1 (General Purpose) | Stall prevention during deceleration is enabled. The DC bus voltage level is monitored, and the deceleration rate is automatically extended to prevent an overvoltage condition. This deceleration rate may be longer than the set value (B5-02). |

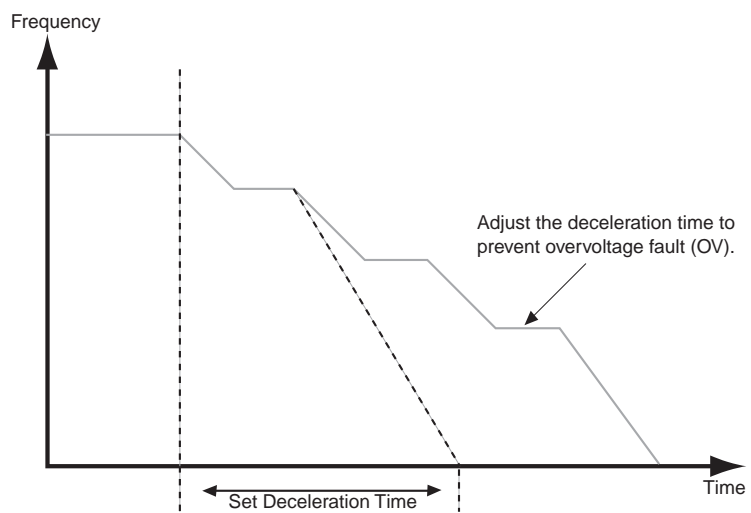

Figure 5-45: Stall Prevention During Deceleration

Reference Detection

The IMPULSE•VG+ Series 2 utilizes three different functions for detecting output frequency:

- When frequency agree is enabled using the multi-function contact outputs (H2-XX="2" or "13"), the contact closes whenever the output frequency "agrees" with the frequency reference, plus or minus the speed agree detection width.
- When desired frequency agree is enabled using the multi-function contact outputs (H2-XX="3" or "14"), the contact closes whenever the output frequency "agrees" with the speed agree detection level, plus or minus the speed agree detection width.
- When frequency detection is enabled using the multi-function contact outputs (H2-XX="4", "5", "15" or "16"), the contact closes whenever the output frequency is less than or more than the speed agree detection level, depending on which detection is selected.

| Parmtr Code | Display | Function | Range | Initial Value | Access Level |
|-------------|-----------------|-------------------|--------------|---------------|--------------|
| L4-01 | Spd Agree Level | Speed Agree Level | 0.0–150.0 Hz | 0.0 | Adv |

Sets the detection level for the desired frequency agree 1 and frequency detection 1 and 2 functions. The set detection level is effective during both FWD and REV operation.

| Parmtr Code | Display | Function | Range | Initial Value | Access Level |
|-------------|-----------------|-------------------|-------------|---------------|--------------|
| L4-02 | Spd Agree Width | Speed Agree Width | 0.0–20.0 Hz | 2.0 | Adv |

Sets the detection width for frequency and desired frequency agree 1 and frequency detection 1 and 2 functions.

| Parmtr Code | Display | Function | Range | Initial Value | Access Level |
|-------------|-------------------|---------------------|-----------------|---------------|--------------|
| L4-03 | Speed Agree Lvl ± | Speed Agree Level ± | -400.0–150.0 Hz | 0.0 | Adv |

Sets the detection level for the desired frequency agree 2 and frequency detection 3 and 4 functions. The set detection level is effective during either FWD or REV operation, depending on the set detection level (positive value for FWD operation, negative value for REV operation).

| Parmtr Code | Display | Function | Range | Initial Value | Access Level |
|--------------------|---------------------|---------------------|--------------|----------------------|---------------------|
| L4-04 | Speed Agree Width ± | Speed Agree Width ± | 0.0–20.0 Hz | 2.0 | Adv |

Sets the detection width for frequency and desired frequency agree 2 and frequency detection 3 and 4 functions.

| Parmtr Code | Display | Function | Range | Initial Value | Access Level |
|--------------------|-----------------------------|---|--------------|----------------------|---------------------|
| L4-05 | Ref Loss Sel | Selects operation when the frequency reference of the control terminal is reduced by 90% within 400ms | | 0 | Adv |
| | <i>0 Stop</i> | | | | |
| | <i>1 Run @ 80% Prev Ref</i> | | | | |

Torque Detection

The overtorque detection circuit activates when the motor load causes the motor current to exceed the overtorque detection level (L6-02). When an overtorque condition is detected, alarm signals can be sent to the multi-function output terminals 9, 25 and 26. To output an overtorque detection signal, select torque detection 1 at either of the multi-function contact outputs (H2-XX="B" or "17"). Refer to the H2 section Digital Output on page 5-85 for more details.

| Parmtr Code | Display | Function | Range | Initial Value | Access Level |
|-------------|-------------------------------|--|-------|---------------|--------------|
| L6-01 | Torque Det 1 Sel | Activates overtorque detection and selects whether detection generates an alarm or a fault | | 0 | Adv |
| | 0 <i>Disable</i> | (See Table 5.14 for details) | | | |
| | 1 <i>At Speed Agree-Alarm</i> | | | | |
| | 2 <i>At Run-Alarm</i> | | | | |
| | 3 <i>At Speed Agree-Fault</i> | | | | |
| | 4 <i>At Run-Fault</i> | | | | |

Table 5.14

| Setting | Description |
|---------|---|
| 0 | Overtorque detection is disabled (<i>factory default</i>). |
| 1 | Overtorque detection is enabled whenever the speed agree level (when inverter is not accelerating or decelerating). Continue running after detection (OL3 alarm). |
| 2 | Overtorque detection is enabled always. Continue running after detection (OL3 alarm). |
| 3 | Overtorque detection is enabled whenever at the speed agree level. Coast to a stop after detection (OL3 fault). |
| 4 | Overtorque detection is enabled always. Coast to a stop after detection (OL3 fault). |

- NOTE:**
- *To detect torque during acceleration or deceleration, set to "2" or "4."*
 - *To continue operation after overtorque detection, set to "1" or "2." During detection, the digital operator displays an "OL3" alarm (blinking).*
 - *To stop the inverter after an overtorque detection fault, set to "3" or "4". During detection, the digital operator displays an "OL3" fault.*

| Parmtr Code | Display | Function | Range | Initial Value | Access Level |
|-------------|-----------------|---|--------------|---------------|--------------|
| L6-02 | Torq Det 1 Lvl | Sets the overtorque detection as a percentage of inverter rated current, during V/f control, and motor rated torque during vector control. | 0–300% | 150% | Adv |
| L6-03 | Torq Det 1 Time | The overtorque detection delay time inserts a delay, between the time motor current (or torque) exceeds the overtorque level (L6-02) and when the overtorque detection function is enabled. The digital operator then displays “OL3”. | 0.0–10.0 sec | 0.1 sec | Adv |

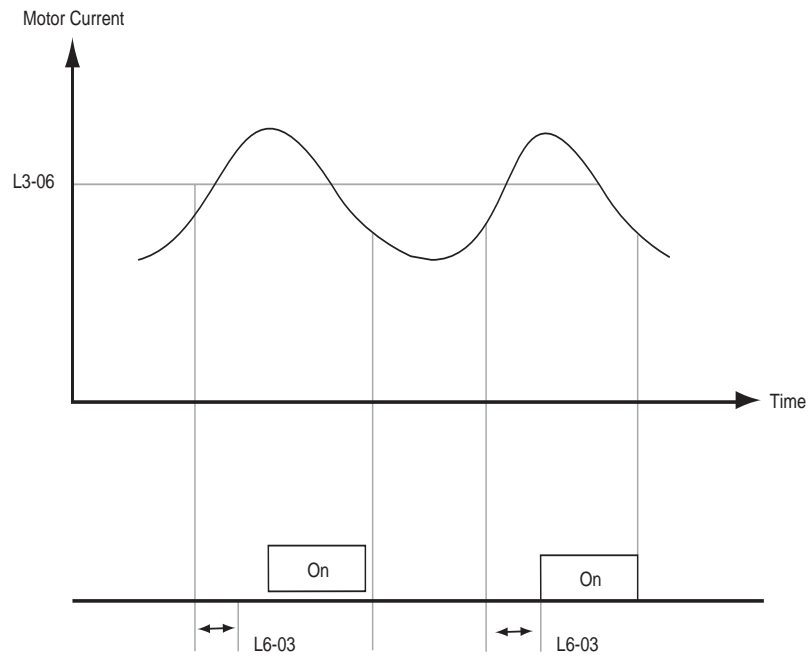

Figure 5-45: Overtorque Characteristics Timing Diagram

| Parmtr code | Display | Function | Range | Initial Value | Access Level |
|--------------------|-------------------------------|--|--------------|----------------------|---------------------|
| L6-04 | Torq Det 2 Sel | Activates overtorque detection, and selects whether detection generates an alarm or a fault. | | 0 | Adv |
| | 0 <i>Disable</i> | (See Table 5.15 for details) | | | |
| | 1 <i>At Speed Agree-Alarm</i> | | | | |
| | 2 <i>At Run-Alarm</i> | | | | |
| | 3 <i>At Speed Agree-Fault</i> | | | | |
| | 4 <i>At Run-Fault</i> | | | | |

Table 5.15:

| Setting | Description |
|----------------|--|
| 0 | Overtorque detection is disabled (<i>factory default</i>). |
| 1 | Overtorque detection is enabled whenever at the speed agree level (when inverter is not accelerating or decelerating). Continue running after detection (OL4 alarm). |
| 2 | Overtorque detection is enabled always. Continue running after detection (OL4 alarm). |
| 3 | Overtorque detection is enabled whenever at the speed agree level. Coast to a stop after detection (OL4 fault). |
| 4 | Overtorque detection is enabled always. Coast to a stop after detection (OL4 fault). |

Overtorque detection 2 functions the same as overtorque detection 1 (*L6-01*), except that “OL4” is displayed on the digital operator instead. This function is used when two types of detection are output to the multi-function output terminals.

| Parmtr Code | Display | Function | Range | Initial Value | Access Level |
|--------------------|-----------------|--------------------------|--------------|----------------------|---------------------|
| L6-05 | Torq Det 2 Lvl | Torque Detection 2 Level | 0–300% | 150% | Adv |
| L6-06 | Torq Det 2 Time | Torque Detection 2 Time | 0.0–10.0 sec | 0.1 sec | Adv |

Hardware Protection

The IMPULSE•VG+ Series 2 comes equipped with a number of built-in functions designed to protect the inverter and its components from damage.

| Parmtr Code | Display | Function | Range | Initial Value | Access Level |
|--------------------|---------------------|--|--------------|----------------------|---------------------|
| L8-02 | OH Pre-Alarm Lvl | Sets the heatsink temperature level for protection against overheating (OH). Note: The inverter measures heatsink temperature by a negative temperature coefficient thermistor. | 50–110°C | 95°C | Adv |
| L8-03 | OH Pre-Alarm Sel | Selects the stopping method when heatsink overheating is detected. | | 3 | Adv |
| | 0 Ramp to Stop | (Decel to stop using B5-02) | | | |
| | 1 Coast to Stop | (Immediate stop) | | | |
| | 2 Fast-Stop | (Decel to stop using B5-08) | | | |
| | 3 Alarm Only | (Operation continues and "OH Heatsink Overtemp" is displayed on keypad) | | | |
| L8-10 | Ground Fault Detect | Enables/disables ground fault detection | | 1 | Adv |
| | 0 Disabled | | | | |
| | 1 Enabled | | | | |
| L8-14 | UV3 Detect | Enables/disables UV3 detection (MC-Answer Back) | | 0 | Adv |
| | 0 Disabled | | | | |
| | 1 Enabled | | | | |

Automatic Reset

When a fault occurs during operation, the IMPULSE•VG+ Series 2 can be programmed for an auto restart operation to automatically reset the fault.

| Parmtr Code | Display | Function | Range | Initial Value | Level Access |
|-------------|---|--|--------------|---------------|--------------|
| L9-01 | Reset Select 0 Disabled 1 Enabled | Activates the fault auto-reset function. | | 1 | Adv |
| L9-02 | Reset Attempts | Sets the number of reset attempts. Reset attempt counter is returned to zero if no faults occur within a ten minute period. | 0–10 | 3 | Adv |
| L9-03 | Reset Time | Sets the reset starting time | 0.0–10.0 sec | 0.5 | Adv |
| L9-04* | Reset Flt Sel 1 | Reset Fault Select 1. | 0000–FFFF | 0001 | Adv |
| L9-05* | Reset Flt Sel 2 | Reset Fault Select 2. | 0000–FFFF | 0080 | Adv |

* To program constant L9-04 and L9-05, refer to the example on the following page and follow steps 1 through 4:

1. Sign 1 to each fault code that you wish to enable the auto reset.
2. Sign 0 to each fault code that you wish to disable the auto reset.
3. Convert all Digits (1 to 4) from binary to hex.
4. Program L9-04 and L9-05 by entering the hex number obtained from step 3.

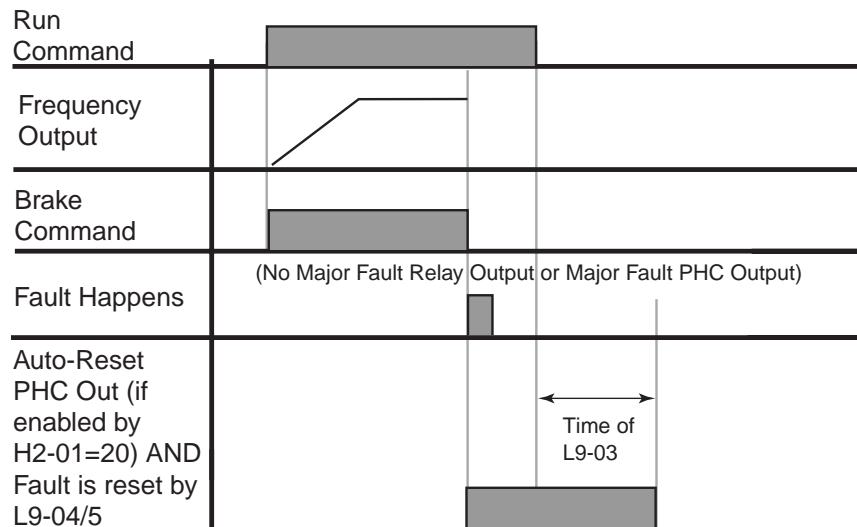

Figure 5-47: Automatic Fault Reset

Example:

Enable auto-reset for UV1, OS and CE faults.

Table 5.16

| | Digit 4 | Digit 3 | Digit 2 | Digit 1 |
|--------|---------------------------|---------------------------|----------------------------------|-------------------------------|
| HEX | 2 | 0 | 0 | 1 |
| Binary | 0 0 1 0 | 0 0 0 0 | 0 0 0 0 | 0 0 0 1 |
| L9-04 | D P O R E G S H V O | L P O O F F L L 2 1 | O S O G H C V F | O U U U C V V V 3 2 1 |
| HEX | 0 | 0 | 8 | 0 |
| Binary | 0 0 0 0 | 0 0 0 0 | 1 0 0 0 | 0 0 0 0 |
| L9-05 | - - - - | - - - S V E | C C E E E A F F L 8 7 L | E E E E F F F F 6 5 4 3 |

Table 5.17

| L9-04 | Binary | HEX |
|--------------|---------------|------------|
| Digit 4 | 0010 | 2 |
| Digit 3 | 0000 | 0 |
| Digit 2 | 0000 | 0 |
| Digit 1 | 0001 | 1 |

Table 5.18

| Binary Number | Hexadecimal Number |
|----------------------|---------------------------|
| 0000 | 0 |
| 0001 | 1 |
| 0010 | 2 |
| 0011 | 3 |
| 0100 | 4 |
| 0101 | 5 |
| 0110 | 6 |
| 0111 | 7 |
| 1000 | 8 |
| 1001 | 9 |
| 1010 | A |
| 1011 | B |
| 1100 | C |
| 1101 | D |
| 1110 | E |
| 1111 | F |

Operator Parameters

- O1 Monitor Selection
- O2 Keypad Key Selection
- O3 Clear History

Monitor Selection

The top level in the operation mode allows the viewing of four monitor variables. They are Fref, Fout, Iout, and User-Selected monitor. This user-selected monitor can be selected from the following table. See Monitor Parameters table on page 5-109 for available monitors by control method.

| Parmtr Code | Display | Function | Range | Initial Value | Access Level |
|--------------------|---------------------|--|--------------|----------------------|---------------------|
| O1-01 | User Monitor Sel | Assigns one of the following monitor parameter as user-selected monitor. | 4-35 | 6 | Adv |
| | 4 Control Method | | | | |
| | 5 Motor Speed | | | | |
| | 6 Output Voltage | | | | |
| | 7 DC Bus Voltage | | | | |
| | 8 Output kWatts | | | | |
| | 9 Torque Reference | | | | |
| | 10 Input Term Sts | | | | |
| | 11 Output Term Sts | | | | |
| | 12 Int Ctl Sts 1 | | | | |
| | 13 Elapsed Time | | | | |
| | 14 FLASH ID | | | | |
| | 15 Term 13 Level | | | | |
| | 16 Term 14 Level | | | | |
| | 17 Term 16 Level | | | | |
| | 18 Mot SEC Current | | | | |
| | 19 Mot EXC Current | | | | |
| | 20 SFS Output | | | | |
| | 21 ASR Input | | | | |
| | 22 ASR Output | | | | |
| | 23 Speed Deviation | | | | |
| | 24 PID Feedback | | | | |
| | 25 DI-16 Reference | | | | |
| | 26 Voltage Ref (Vq) | | | | |
| | 27 Voltage Ref (Vd) | | | | |
| | 28 CPU ID | | | | |
| | 29 Load Weight | | | | |
| | 32 ACR(q) Output | | | | |
| | 33 ACR(d) Output | | | | |

| Parmtr Code | Display | Function | Range | Initial Value | Access Level |
|--------------------|---------------------------|--|--------------|----------------------|---------------------|
| | 34 <i>OPE Detected</i> | | | | |
| | 35 <i>Friction Torque</i> | | | | |
| O1-02 | Power-On Monitor | Selects the monitor to be displayed on the digital operator immediately after the power supply is turned on. | | 2 | Adv |
| | 1 <i>Frequency Ref</i> | (U1-01) | | | |
| | 2 <i>Output Freq</i> | (U1-02) | | | |
| | 3 <i>Output Current</i> | (U1-03) | | | |
| | 4 <i>User Monitor</i> | (01-01) | | | |
| O1-03 | Display Scaling | Units for parameters and monitor related to frequency reference and output frequency can be scaled as shown below. | 0–39999 | 0 | Adv |

Table 5.19

| Setting (O1-03) | Description |
|---|--|
| 00000 | Unit: 0.01Hz (factory default) |
| 00001 | Unit: 0.01% |
| 00002 to 00039 | Unit: rpm (set O1-03 equal to the number of motor poles) |
| 00040 to 39999 (user-selected units) | <p>Digits: $\frac{5\text{th}}{0}$ $\frac{4\text{th}}{0}$ $\frac{3\text{rd}}{0}$ $\frac{2\text{nd}}{0}$ $\frac{1\text{st}}{0}$</p> <p>The first through fourth digits determine the set value at 100% output frequency. Decimal point position is set by the fifth digit as follows:</p> <p>5th digit = 0: displayed as 0000 5th digit = 1: displayed as 000.0 5th digit = 2: displayed as 00.00 5th digit = 3: displayed as 0.000</p> <p>Example 1 If 100% output frequency is equal to 200.0 units: Set O1-03="12000"; 100% of this reference is displayed as 200.0 and 60% of this reference is displayed as 120.0.</p> <p>Example 2 If 100% output frequency is equal to 65.00: Set O1-03="26500"; 60% of this reference is displayed as 39.00.</p> |

| Parmtr Code | Display | Function | Range | Initial Value | Access Level |
|-------------|--|--|-------|---------------|--------------|
| O1-04 | Display Units 0) Hertz 1) RPM | Display units for motor speed | | 0 | Adv |
| O1-05 | Address Display 0 Parameter Number 1 MEMOBUS Address | Selects how the parameter addresses are displayed on the digital operator. | | 0 | Adv |

Keypad Key Selection

| Parmtr Code | Display | Function | Range | Initial Value | Access Level |
|-------------|--------------------------------|--|-------|---------------|--------------|
| O2-01 | Mode/Service 0 Mode/Service | Pressing the Mode/Service Key once displays "Call ESI Service" 800-288-8178. | | 0 | Adv |

Pressing the Mode/Service Key a second time:

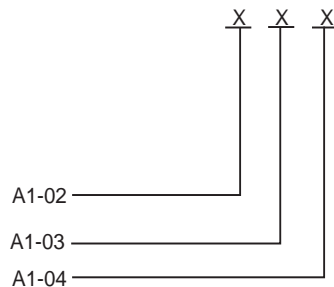

| | | | | | |
|-------|--|--|--|---|-----|
| | 1 Remote Local | Local/remote key is enabled depressing the local/remote key switches operation command between the digital operator and the settings of B3-01 and B3-02. | | | |
| O2-02 | Oper Stop Key 0 BB, Brake Set 1 Decel tim1 Stop 2 Decel tim2 Stop 3 Decel Fault Stop | Selects the action when the digital stop key is pressed. (Immediate stop) (B5-02) (B5-04) (B5-08) | | 0 | Adv |
| O2-03 | User Defaults | | | 0 | Adv |

0 No Change

1 Set Defaults

Memorizes up to 50 modified parameters. User defaults can be restored by setting A1 - 05= "1110".

2 Clear all

Clear user defaults

| | | | | |
|-------|---------------|---|-------|-----|
| O2-04 | KVA Selection | Determines the model number of the drive, which is based on the kVA rating. The following in this column are Electromotive Systems model numbers. | 00-FF | Adv |
| | 0 20P4 | Not used. | | |
| | 1 20P7 | 2006-FVG+ | | |
| | 2 21P5 | 2008-FVG+ | | |
| | 3 22P2 | 2011-FVG+ | | |
| | 4 23P7 | 2017-FVG+ | | |
| | 5 25P5 | 2025-FVG+ | | |
| | 6 27P5 | 2033-FVG+ | | |
| | 7 2011 | 2054-FVG+ | | |
| | 8 2015 | 2068-FVG+ | | |
| | 9 2018 | 2080-FVG+ | | |
| | A 2022 | Not used | | |
| | B 2030 | 2130-FVG+ | | |
| | C 2037 | 2160-FVG+ | | |
| | D 2045 | Not used | | |
| | E 2055 | 2224-FVG+ | | |
| | F) 2075 | 2300-FVG+ | | |
| | 20 40P4 | 4001-FVG+ | | |
| | 21 40P7 | 4003-FVG+ | | |
| | 22 41P5 | 4005-FVG+ | | |
| | 23 42P2 | Not used | | |
| | 24 43P7 | 4008-FVG+ | | |
| | 25 44P0 | 4011-FVG+ | | |
| | 26 45P5 | 4014-FVG+ | | |
| | 27 47P5 | 4021-FVG+ | | |
| | 28 4011 | 4028-FVG+ | | |
| | 29 4015 | 4034-FVG+ | | |
| | 2A 4018 | 4041-FVG+ | | |
| | 2B 4022 | 4052-FVG+ | | |
| | 2C 4030 | 4065-FVG+ | | |
| | 2D 4037 | 4080-FVG+ | | |
| | 2E 4045 | 4096-FVG+ | | |
| | 2F 4055 | 4128-FVG+ | | |
| | 30 4075 | 4165-FVG+ | | |
| | 31) 4090 | Not Used | | |
| | 32 4110 | 4224-FVG+ | | |
| | 33) 4132 | Not Used | | |
| | 34 4160 | 4302-FVG+ | | |

| | | | | |
|-------|------------------|--|---------|---|
| 35 | 4185 | Not used | | |
| 36 | 4220 | 4450-FVG+ | | |
| 37 | 4300 | 4605-FVG+ | | |
| 42 | 51P5 | 5003-FVG+ | | |
| 43 | 52P2 | 5004-FVG+ | | |
| 44 | 53P7 | 5006-FVG+ | | |
| 45 | 55P5 | 5009-FVG+ | | |
| 46 | 57P5 | 5012-FVG+ | | |
| 47 | 5011 | 5017-FVG+ | | |
| 48 | 5015 | 5022-FVG+ | | |
| 49 | 5018 | 5027-FVG+ | | |
| 4A | 5022 | 5032-FVG+ | | |
| 4B | 5030 | 5041-FVG+ | | |
| 4C | 5037 | 5052-FVG+ | | |
| 4D | 5045 | 5062-FVG+ | | |
| 4E | 5055 | 5077-FVG+ | | |
| 4F | 5075 | 5099-FVG+ | | |
| 50 | 5090 | 5130-FVG+ | | |
| 51 | 5110 | 5172-FVG+ | | |
| 52 | 5160 | 5200-FVG+ | | |
| O2-05 | Up/Down Freq Ref | Selects whether the ENTER key is used when the frequency reference is set by the digital operator. The digital operator can simulate a motor operated potentiometer (M.O.P.) by setting this parameter. | 0 | Adv |
| | 0 Disabled | ENTER Key Required | | |
| | 1 Enabled | ENTER Key Not Required | | |
| | | | | <i>Note: This feature cannot be used in conjunction with infinitely variable speed control.</i> |
| O2-06 | Oper Detection | If the digital operator is disconnected from the inverter. This parameter selects whether the inverter detects this condition. The operator is only detected when the inverter is being commanded locally. | 1 | Adv |
| | 0 Disabled | | | |
| | 1 Enabled | | | |
| O2-07 | Elapsed Time Set | Viewable by U1-13 | 0-65535 | 0 Adv |
| O2-08 | Elapsed Time Run | Defines the operation time that accumulates in the timer. | 1 | Adv |
| | 0 Power-On Time | | | |
| | 1 Running Time | | | |

| | | | | | |
|-------|-------------------|--|--------|-----------------|-----|
| O2-10 | Run @ Power Up | When enabled, allows the drive to start running immediately upon Power up. When disabled, if a run command is present at Power up, an "EF" will flash on the keypad. Upon Cycling the run command, the "EF" will reset and operation can continue. | 0 to 1 | 0 (disabled) | Adv |
| | <i>0 Disabled</i> | | | | |
| | <i>1 Enabled</i> | | | | |

Clear History

| Parmtr Code | Display | Function | Range | Initial Value | Access Level |
|--------------------|--------------------------|--------------------------------|--------------|----------------------|---------------------|
| 03-01 | Clear History 1 | Clears fault history | 0 to 1 | 0 | Adv |
| | <i>0 Not Clear</i> | | | | |
| | <i>1 Clear</i> | | | | |
| 03-02 | Clear History 2 | Clears count history. | 0 to 4 | 0 | Adv |
| | <i>0 Not Clear</i> | | | | |
| | <i>1 AC Count Clr</i> | Clears AC operations (U3-09). | | | |
| | <i>2 OL/LC Count Clr</i> | Clears OL/LC (U3-10). | | | |
| | <i>3 Both Count Clr</i> | Clears Both (U3-09 and U3-10). | | | |
| | <i>4 U1-54 Clear</i> | Clears U1-54 U3-09 Rollovers | | | |

Monitor Parameters

| Parmtr Code | Display | Function | Units | Access Level |
|--------------------|------------------------|---|--------------|---------------------|
| Monitor | | | | |
| U1-01 | Frequency Ref | Frequency Reference | Hz | Operation |
| U1-02 | Output Frequency | Inverter Output Frequency | Hz | User Program |
| U1-03 | Output Current | Inverter Output Current | A | User Program |
| U1-04 | Control Method | Displays the value of A1-02 | n/a | User Program |
| U1-05 | Motor Speed | Motor Speed | Hz | User Program |
| U1-06 | Output Voltage | Inverter Output Voltage (Reference) | V | User Program |
| U1-07 | DC Bus Voltage | DC Bus Voltage (Measured) | V | User Program |
| U1-08 | Output kWatts | Inverter Output Power (Calculated) | kW | User Program |
| U1-09 | Torque Reference | Torque Reference (Internal) | % | User Program |
| U1-10 | Input Term Sts | Input Terminal Status (See page 5-113 for a detailed description.) | n/a | User Program |
| U1-11 | Output Term Sts | Output Terminal Status (See page 5-114 for a detailed description.) | n/a | User Program |
| U1-12 | Int Ctl Sts 1 | Operation Status (See page 5-115 for a detailed description.) | n/a | User Program |
| U1-13 | Elapsed Time | Elapsed Time. See O2-07 and O2-08. | hours | User Program |
| U1-14 | Flash ID | Flash ROM software ID number | n/a | User Program |
| U1-15 | Terminal 13 Level | External Terminal 13 input level | V | Advanced |
| U1-16 | Terminal 14 Level | External Terminal 14 input level | V/mA | Advanced |
| U1-17 | Terminal 16 Level | External Terminal 16 input level | V | Advanced |
| U1-18 | Mot SEC Current | Motor secondary current (Iq). | A | Advanced |
| U1-19 | Mot EXC Current | Motor excitation current (Id). | A | Advanced |
| U1-20 | SFS Output | Primary freq. after the SFS | Hz | Advanced |
| U1-21 | ASR Input | Monitors the input to the speed regulator. 100%=FMAX | % | Advanced |
| U1-22 | ASR Output | Monitors the output from the speed regulator. The motor's secondary current corresponds to 100%. | % | Advanced |
| U1-23 | Speed Deviation | Monitors the speed deviation within the speed regulator. FMAX=100% | % | Advanced |
| U1-24 | PID Feedback | PID feedback signal level | % | Advanced |
| U1-25 | G5IN4 Reference | See page 5-45. | Hex | Advanced |
| U1-26 | Voltage Reference (Vq) | Motor secondary voltage reference | V | Advanced |
| U1-27 | Voltage Reference (Vd) | Motor excitation voltage reference | V | Advanced |
| U1-28 | CPU ID | CPU software ID number | n/a | Advanced |

| Parmtr Code | Display | Function | Units | Access Level |
|--------------------|-----------------|--|--------------|---------------------|
| U1-29 | Load Weight | Monitors load weight when C10-01 is enabled | tons | Advanced |
| U1-32 | ACR (q) Output | | % | Advanced |
| U1-33 | ACR (d) Output | | % | Advanced |
| U1-34 | OPE Detected | | const # | Advanced |
| U1-35 | Friction Torq | | % | Advanced |
| U1-54 | U3-09 Rollovers | Number of times U3-09 has rolled over 10,000 | n/a | Advanced |
| U1-55 | Software rev | Revisions of Flash Id (U1-14) | n/a | Advanced |

Fault Trace

| | | | | |
|-------|---------------------|---|-------|--------------|
| U2-01 | Current Fault | Displays current fault | | User Program |
| U2-02 | Last Fault | Displays last fault detected | | User Program |
| U2-03 | Frequency Reference | Freq ref when fault was detected | Hz | User Program |
| U2-04 | Output Frequency | Output freq when fault was detected | Hz | User Program |
| U2-05 | Output Current | Output current when fault was detected | A | User Program |
| U2-06 | Motor Speed | Motor Speed when the “Last Fault” occurred | | User Program |
| U2-07 | Output Voltage | Output voltage when fault was detected | V | User Program |
| U2-08 | DC Bus Voltage | DC Bus voltage when fault was detected | V | User Program |
| U2-09 | Output kWatts | Output power when fault was detected | kW | User Program |
| U2-10 | Torque Reference | Torque Reference when the “Last Fault” occurred | | User Program |
| U2-11 | Input Terminal Sts | Input terminal status when fault was detected | n/a | User Program |
| U2-12 | Output Terminal Sts | Output terminal status when fault was detected | n/a | User Program |
| U2-13 | Inverter Status | Inverter status before fault was detected | n/a | User Program |
| U2-14 | Elapsed Time | Elapsed time when fault was detected | hours | User Program |

Fault History

| | | | | |
|-------|-----------------|---------------------------------------|--|--------------|
| U3-01 | Last Fault | Most recent fault | | User Program |
| U3-02 | Fault Message 2 | 2nd most recent fault | | User Program |
| U3-03 | Fault Message 3 | 3rd most recent fault | | User Program |
| U3-04 | Fault Message 4 | 4th most recent fault | | User Program |
| U3-05 | Elapsed Time 1 | Elapsed time of most recent fault | | User Program |
| U3-06 | Elapsed Time 2 | Elapsed time of 2nd most recent fault | | User Program |
| U3-07 | Elapsed Time 3 | Elapsed time of 3rd most recent fault | | User Program |

| Parmtr Code | Display | Function | Units | Access Level |
|--------------------|----------------|--|--------------|---------------------|
| U3-08 | Elapsed Time 4 | Elapsed time of 4th most recent fault | | User Program |
| U3-09 | AC Operations | Total number of RUN commands received since the AC counter was last cleared (03-02) | | User Program |
| U3-10 | OL/LC Count | Total number of (Overload) and (Load Check) faults detected since the OL/LC counter was last cleared (03-02) | | User Program |

U1-10 Input Terminal Status

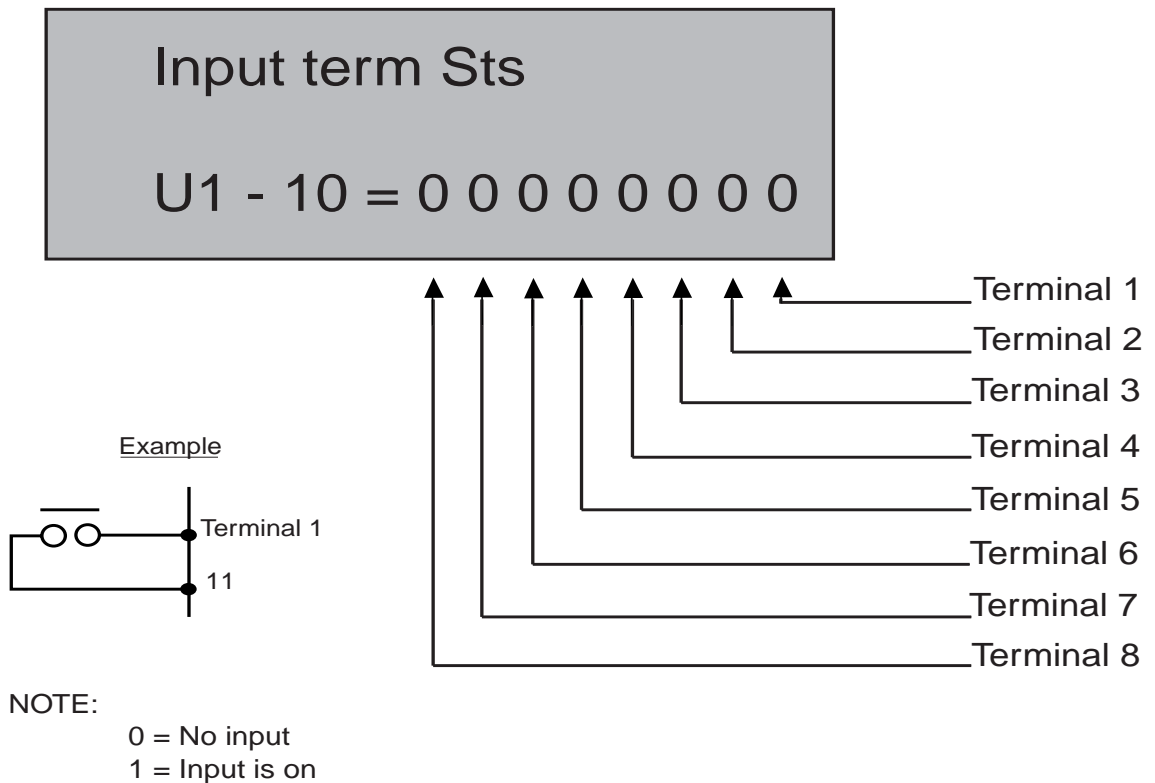

Figure 5-48: Input Terminal Status

U1-11 Output Terminal Status

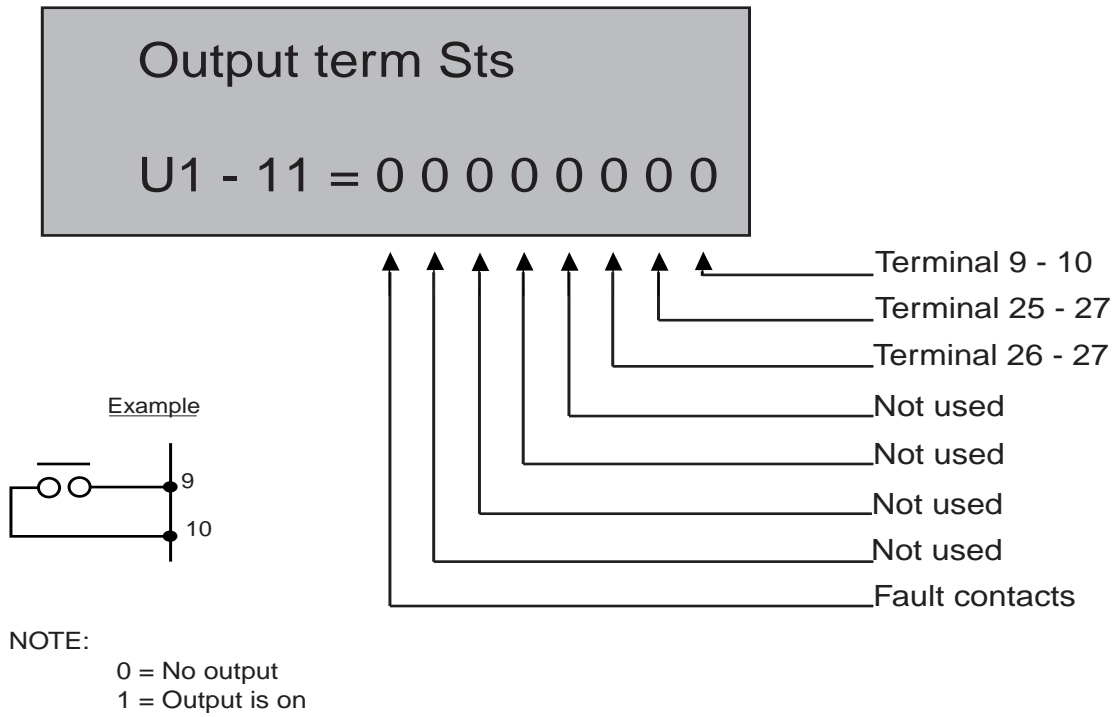
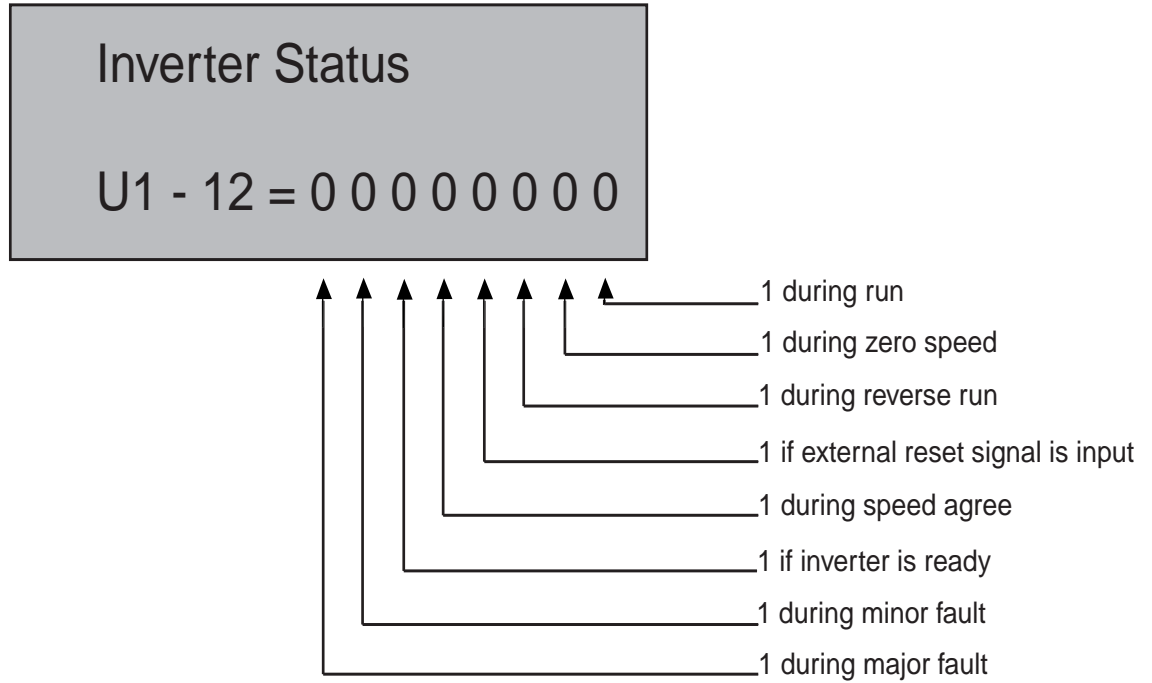

Figure 5-50: Output Terminal Status

U1-12 Inverter Status



NOTE:
0 = Inactive
1 = Active

Figure 5-49: Inverter Status

This page intentionally left blank.

c h a p t e r **6**

**Troubleshooting
IMPULSE•VG+ Series 2**

This page intentionally left blank.

Troubleshooting the Drive

In this troubleshooting section, “*check,*” means *investigating whether an item is functioning and in an acceptable physical condition, and then taking corrective action (adjusting, fixing, replacing, etc.) as necessary.* In the Corrective Action column, you may not have to perform all of the steps to correct the problem.

Maintenance and Inspection

This section describes basic maintenance and inspection procedures for the IMPULSE•VG+ Series 2.

| Component | Check | Corrective Action |
|---|--|--|
| External terminals, connectors, mounting screws, etc. | Loose screws or connectors | Securely tighten. |
| Heatsink | Build-up of dust and dirt | Blow with dry, compressed air (57-86 psi). |
| Printed Circuit Board (PCB) | Accumulation of conductive dust or oil | Blow with dry, compressed air (57-86 psi). If dust and oil cannot be removed, replace the board. |
| Cooling Fan | Abnormal noise and vibration | Clean or replace the fan. |
| Power Components | Accumulation of dust or dirt | Blow with dry, compressed air (57-86 psi). |

Alarm and Fault classes are described as follows:

- Major Fault: Brake is set, operation indicator lights flash, fault is displayed on keypad and fault contact output (terminals 18, 19 & 20) are activated. The reset key must be pressed, a multi-function input set for fault reset or power must be cycled in order to continue operation.
- Fault (minor): Brake is set, RUN Led flashes until run command is removed, fault is displayed on keypad, fault contact output (terminals 18, 19 & 20) are not activated. The reset key does not need to be pressed. The drive will attempt to run again at the next run command.
- Alarm (Warning): Operation continues, fault is displayed on the keypad, fault contact output (terminals 18, 19 & 20) are not activated.

Motor Faults and Corrective Actions

| Symptom | Corrective Action |
|--|---|
| Analog frequency reference is not stable. (drifting) | <ol style="list-style-type: none"> 1. Stabilize the analog source. 2. Increase B2-02. 3. Increase B5-01, -02. |
| No motor rotation. | <ol style="list-style-type: none"> 1. Verify that power is on (Charge LED). 2. Verify that the keypad display is not showing a fault. 3. Verify that the run command is input to the drive (U1-10). 4. Motor stalled due to excessive load. |
| Motor rotation is in the wrong direction. | <ol style="list-style-type: none"> 1. Verify FWD/REV or UP/DN is correct at the interface card. 2. Match wiring to the phase order of the motor leads T1, T2, T3. |
| Motor rotates, but at minimum speed only. | <ol style="list-style-type: none"> 1. Check wiring of speed inputs. 2. Verify speed reference setting (A1-04). 3. Verify reference and run source settings are correct (B3-01, -02). 4. Verify reference priority setting (B1-10). |
| Motor RPM too high or too low. | <ol style="list-style-type: none"> 1. Compare motor nameplate specifications with E1 parameter. 2. Check maximum frequency setting (E1-04). 3. Check minimum frequency setting (E1-09). |

Drive Faults and Indicators

| Fault Code | Fault or Indicator Name/Description | Corrective Action |
|-------------------------------|--|---|
| BB Base Block | External Base Block Indicator. The flashing base block signal is the result of a multi-function input in the terminal strip. The base block indicates that the drive's IGBTs have been disabled. The motor will begin coasting when the base block input is received. If a RUN command is still present when the BB signal is removed, the output voltage will be restored to the previous operating level and operation will continue at the previously commanded frequency. | <ol style="list-style-type: none"> 1. Check constants H1-01 through H1-06 for proper programming. 2. Check terminal status. (U1-10) |
| BE0 Brake Ans Lost | Brake answer back signal is lost during run. While running, the multi-function input brake answer back is lost. | <ol style="list-style-type: none"> 1. Check brake answer back circuit. 2. Check terminal status. (U1-10) |
| BE1 Rollback detect | Torque Proving Minor Fault. The BE1 fault indicates that the drive has released the brake, but not started to accelerate the motor when it detects more than the expected encoder feedback. A BE1 fault will occur if the pulses received during the BE1 detection time (C8-04) are greater than the expected number of pulses (C8-05). | <ol style="list-style-type: none"> 1. Please reference troubleshooting encoder related faults on page 6-16. |

| Fault Code | Fault or Indicator Name/Description | Corrective Action |
|----------------------------------|---|---|
| BE2 No Current | Torque Proving Minor Fault. Before the brake is released, the drive's current did not reach a predetermined level within a predetermined time. | <ol style="list-style-type: none"> 1. For reference, see timing diagram on page 5-38 2. Ensure the motor has been Auto-tuned successfully. 3. If a powerlimit switch is used, ensure that the switch is closed. 4. Decrease the values of C8-01 and C8-02 to no less than .5 seconds. <i>NOTE: The values of C8-01 and C8-02 should always remain equal.</i> 5. Decrease the value of C4-02 to no less than 5. 6. Decrease the value of C8-16 to no less than 50. |
| BE3 Brake Release NG | Torque Proving Minor Fault. The BE3 fault indicates that the drive has released the brake and commanded the drive to run, but it has not detected the expected encoder feedback. A BE3 fault will occur if the pulses received during the BE3 detection time (C8-06) are less than the expected number of pulses (C8-07). | <ol style="list-style-type: none"> 1. Please reference encoder related faults on page 6-16. |
| BE4 Brake Answer 1 | Brake Answer-Back Minor Fault Released. At Start, Brake Answer-back is not input within predetermined time (C8-04) after electric brake release command is output—Electric brake not released. | <ol style="list-style-type: none"> 1. See NLB_UP on page 5-38. 2. Check brake answer back circuit. 3. Increase the value of C8-04. 4. Check terminal status (U1-10). |
| BE5 Brake Answer 2 | Brake Answer-Back At Stop. At Stop, Brake Answer-back signal is not removed within predetermined time (C8-11) after electric brake release command is removed—Electric brake not closed. | <ol style="list-style-type: none"> 1. See NLB_UP on page 5-38. 2. Check brake answer back circuitries 3. Increase the value of C8-11 time. |
| BE6 Brake Stop Fault | Brake Proving Alarm. The BE6 alarm indicates that the drive has commanded the brake to set but it has detected more than the expected encoder feedback. A BE6 alarm will occur if the number of pulses received during the BE6 detection time (C8-12) is greater than the expected number of pulses (C8-13). | <ol style="list-style-type: none"> 1. Please reference troubleshooting encoder related faults on page 6-12. |
| BE7 Brake Welded | Brake Answer-Back Major Fault. At Power Up, Brake Answer-Back is on - Electric brake not closed. | <ol style="list-style-type: none"> 1. Check if brake is closed. 2. Check brake answer back circuitry. |
| CALL Serial Com Call | Serial Communication SI-B Transmission Fault. Control data is not received correctly after power supply is turned ON for 2 sec. | <ol style="list-style-type: none"> 1. Check serial device connections. 2. Ensure drive is properly programmed for serial communication. |
| CE Memobus Com Err | Communication Error. Serial communications disruption. | <ol style="list-style-type: none"> 1. Check serial connections (6 CN). 2. Check H5-01 through H5-05 for proper programming. |
| CPF00 Com-Err (OP&INV) | Control Circuit Fault 1— Keypad Transmission. Because of external noise, excessive vibration or shock, or component failure (including RAM and PROM), one or both of the following occurs: <ul style="list-style-type: none"> • Transmission between the inverter and keypad cannot be established 5 sec after power-up. • MPU peripheral element check fault (on-line). | <ol style="list-style-type: none"> 1. Check the keypad connection. 2. Replace keypad. 3. Replace Control board. |

| Fault Code | Fault or Indicator Name/Description | Corrective Action |
|----------------------------------|--|--|
| CPF01 Com-Err (OP&INV) | Control Circuit Fault 2—Keypad Transmission. After initial power-up, communication between the inverter and keypad was interrupted for more than 2 seconds. | <ol style="list-style-type: none"> 1. Check keypad connection. 2. Cycle Power 3. Replace keypad 4. Replace Control board. |
| CPF02 BB Circuit Err | Base Block Circuit Fault. Base block circuit fault at power-up. | <ol style="list-style-type: none"> 1. Cycle power. 2. Ensure that the control board terminals are shielded from electrical noise. 3. Replace Control board. |
| CPF03 EEPROM Err | EEPROM Fault. Invalid data found in the EEPROM. | <ol style="list-style-type: none"> 1. Cycle power. 2. Ensure that the control board terminals are shielded from electrical noise. 3. Replace Control board. |
| CPF04 Internal A/D Err | Internal A/D Converter Fault. CPU internal analog-digital converter fault. | <ol style="list-style-type: none"> 1. Cycle power. 2. Ensure that the control board terminals are shielded from electrical noise. 3. Replace Control board. |
| CPF05 External A/D Err | External A/D Converter Fault. CPU external analog-digital converter fault. | <ol style="list-style-type: none"> 1. Cycle power. 2. Ensure that the control board terminals are shielded from electrical noise. 3. Replace Control board. |
| CPF06 Option Error | Option Card Fault. Optional card has disconnected or failed. | <ol style="list-style-type: none"> 1. Power down. 2. Verify proper installation of all option cards. |
| CPF10 | Control Circuit Fault 10 — G5IN4. G5IN4 option card failure. | <ol style="list-style-type: none"> 1. Power down. 2. Verify proper installation of G5IN4. 3. Replace G5IN4 card. |
| CPF20 Option A/D Error | Control Circuit Fault 20 — AI-14. Analog-to-digital converter fails or analog speed reference error. | <ol style="list-style-type: none"> 1. Power down. 2. Verify proper installation of AI-14B. 3. Replace AI-14B card. |
| CPF21 Option CPU Down | Control Circuit Fault 21 — CPU on Optional Card. CPU on an installed optional card fails. | <ol style="list-style-type: none"> 1. Power down. 2. Verify proper installation of Option card. 3. Replace card. |
| CPF22 Option Type Err | Control Circuit Fault 22 — Optional Card Code. Optional card code is not compatible with the inverter. | <ol style="list-style-type: none"> 1. Power down. 2. Verify proper card. 3. Verify proper installation of Option card. 4. Replace card. |
| CPF23 Option DPRAM Err | Control Circuit Fault 23 — DP-RAM. DP-RAM on an installed optional card failed. | <ol style="list-style-type: none"> 1. Power down. 2. Remove any inputs to card. 3. Verify proper installation of Option card. 4. Replace card. |
| Dev Speed Deviation | Speed Deviation Fault. Occurs when the deviation of the speed reference and speed feedback exceeds the regulation level, F1-10 for the time F1-11. | <ol style="list-style-type: none"> 1. Please reference troubleshooting encoder related faults on page 6-12. |

| Fault Code | Fault or Indicator Name/Description | Corrective Action |
|---------------------------------------|--|---|
| EF (Blinks) External Fault | Both FORWARD/UP and REVERSE/DOWN commands are input at same time for 500 msec or longer. | 1. Check control input circuitries. 2. Check the sequence of operation. |
| EF0 Optional External Fault | External fault input from communication option card. | 1. Check communication option card connection and signals. |
| EF3 External Fault 3 | External fault occurs in the Terminal 3 external control circuit. | 1. Check constant H1-01 for proper programming. 2. Check the condition of the input terminal #3 on G5IF card. |
| EF4 External Fault 4 | External fault occurs in the Terminal 4 external control circuit. | 1. Check constant H1-02 for proper programming. 2. Check the condition of the input terminal #4 on G5IF card. |
| EF5 External Fault 5 | External fault occurs in the Terminal 5 external control circuit. | 1. Check constant H1-03 for proper programming. 2. Check the condition of the input terminal #5 on G5IF card. |
| EF6 External Fault 6 | External fault occurs in the Terminal 6 external control circuit. | 1. Check constant H1-04 for proper programming. 2. Check the condition of the input terminal #6 on G5IF card. |
| EF7 External Fault 7 | External fault occurs in the Terminal 7 external control circuit. | 1. Check constant H1-05 for proper programming. 2. Check the condition of the input terminal #7 on G5IF card. |
| EF8 External Fault 8 | External fault occurs in the Terminal 8 external control circuit. | 1. Check constant H1-06 for proper programming. 2. Check the condition of the input terminal #8 on G5IF card. |
| ERR EEPROM R/W Err | EEPROM Read/Write Fault. EEPROM internal data did not match when initializing the parameter. | 1. Cycle Power. 2. User initialize (A1-05=1110). 3. Replace Control board. |
| GF Ground Fault | During operation, the inverter sums the currents of all three motor phases. Ideally, the sum should always equal zero. If the sum is greater than 50% of the inverter rated output current, a GF occurs. | 1. Disconnect motor from drive and check it for shorts using a megger. 2. Ensure that R/C Surge Suppressors are used across all brake contactor coils to prevent disturbance by electrical transients. |
| LCI Load Check Err | Load Check Fault. Load is greater than specified amount. | 1. Reduce Load. 2. Check Load Check sequence set-up. (C5-XX). |
| LF Output Pha Loss | An open phase occurred at the inverter output. | 1. Check for broken wires in output cable. 2. Check for open winding in the motor. 3. Check for loose terminals |
| LL1 Lower Limit 1 Err | Lower Limit 1—SLOW DOWN Indicator. Lower Limit 1—SLOW DOWN is input (switch status is changed). | 1. May not require corrective action. 2. Check the Limit Switches position. 3. Check the Limit Switches condition. |
| LL2 Lower Limit 2 Err | Lower Limit 2—STOP Indicator. Lower Limit 2—STOP is input (switch status is changed). | 1. May not require corrective action. 2. Check the Limit Switches position. 3. Check the Limit Switches condition. |

| Fault Code | Fault or Indicator Name/Description | Corrective Action |
|---|---|---|
| MFI MFI Pulse Fault | Multi-Function Input Fault. This fault generated when the encoder position has changed enough that the multi-function input should have changed state but has not yet changed state. | <ol style="list-style-type: none"> 1. Check proximity sensor or other input device for proper operation. 2. Check F1-16 for proper setting. 3. Reduce pulse enable speed (F1-17) |
| OC Over Current | Output current exceeds 200% of inverter rated output current. | <ol style="list-style-type: none"> 1. Check for a phase-to-phase short in the motor or wiring using a megger. 2. Extend the acceleration/deceleration time. 3. Check torque limit setting. 4. Please reference troubleshooting encoder related faults on page 6-12. |
| OH (blinking) Heatsnk Over temp | Overheat Pre-Alarm. Cooling fan is overheating. The temperature of the inverters cooling fans exceeded the setting in L8-02. | <ol style="list-style-type: none"> 1. The inverter cooling fan has stopped. 2. Reduce the ambient temperature. |
| OHI Heatsink MaxTemp | Overheat Fault. There are two situations that result in an overheat fault. The first occurs when the measured heat sink exceeded 105°C. The second is a result of a fault in the internal 24VDC cooling fan. | <ol style="list-style-type: none"> 1. Ensure that the heat sink cooling fans are functioning. 2. Ensure that the heat sink is free from dirt and debris. 3. Ensure that the inverter's ambient temperature is within specification. 4. Replace the 24VDC fan 5. Replace the heat sink thermistor(s) |
| OLI Motor Overloaded | Motor Overload Fault. Inverter output exceeded the motor overload level. | <ol style="list-style-type: none"> 1. Ensure drive is programmed with proper motor full load Amp (E2-01). 2. Reduce the load. |
| OL2 INV Overloaded | Inverter Overload Fault. Inverter output exceeded the inverter overload level. | <ol style="list-style-type: none"> 1. Reduce the load. 2. Extend the acceleration time. |
| OL3 Overtorque Det 1 | Overtorque Detection Level 1 Fault. Defined by L6-02. Alarm defined by L6-01. | <ol style="list-style-type: none"> 1. Check for proper programming for L6-XX constant. |
| OL4 Overtorque Det 2 | Overtorque Detection Level 2 Fault. Defined by L6-05. Alarm defined by L6-04. | <ol style="list-style-type: none"> 1. Check for proper programming for L6-XX constant. |
| OPBUS SI-B Com Err | Communication Option Card Error. | <ol style="list-style-type: none"> 1. Communication error while B3-01 and/or B3-02 (Run source and/or reference source) are from option PCB. |
| OPE01 kVA Selection | kVA Setting Fault. Inverter kVA setting range is incorrect. | <ol style="list-style-type: none"> 1. Check 02-04 constant for proper kVA. |
| OPE02 Limit | Setting Out of Range . Parameter setting is out of range. | <ol style="list-style-type: none"> 1. With the fault displayed on the keypad, press the DATA/ENTER key to reveal the "Out of Range" parameter via the U1-34 monitor. 2. Verify that E2-03 is < E2-01. 3. Verify E1-05 is within range. 4. Compare Modified constants with defaults. 5. Cycle Power. |
| OPE03 Terminal | Multi-Function Input Setting Fault. Set values other than "F" and "FF" are duplicated. | <ol style="list-style-type: none"> 1. Check the settings for H1-01 to H1-06, verify that the same input is not used twice. |

| Fault Code | Fault or Indicator Name/Description | Corrective Action |
|---------------------------------------|---|---|
| OPE05 Sequence Select | Sequence Select Setting Fault. B3-01 and B3-02 and no option is plugged in. | 1. Check the function selection or plug in optional card. |
| OPE06 PG Opt Missing | Missing PG Card. A closed loop control method was selected, and the required PG feedback card is not installed. | 1. Install the required option card. 2. Remove power and reset the option card. 3. Check the A1-02, control method, program setting |
| OPE07 Analog Selection | Multi-Function Analog Input Setting Fault. H3-05 and H3-09 multi-Function analog input settings are set to the same value. | 1. Check the function selections. |
| OPE08 Terminal | Selection Parameter error. A parameter has been changed that is not available in the present control method. Example: H1-08=72 (Zero Servo Command) is set while the drive is in Flux Vector Control (A1-02=3), then the Control Method is changed to Open Loop Vector (A1-02=2). | 1. Undo the last parameter change (if known) 2. Scroll through modified constants for obvious setting errors. 3. Perform a user initialize (A1-05=1110) CAUTION: All settings will be restored to the factory defaults. |
| OPR Oper Disconnect | Keypad Disconnected. The keypad is removed while the inverter is running, and the run command was initiated via the keypad RUN key. | 1. Secure the keypad. 2. Verify O2-06 setting. |
| OS Over Speed | Overspeed Fault. The motor has exceeded the programmed detection level and time. This is typically caused by a overshoot condition due to an over-responsive ASR loop. If the drive is programmed to flux vector “torque control” mode, and no load is present, an overspeed fault will typically occur. | 1. Check the Automatic Speed Regulator settings, D4 sub group. 2. Check for rapid load changes 3. Verify proper encoder PPR setting, F1-01. |
| OV DC Bus Overvolt | Overvoltage Fault. The main circuit direct current voltage exceeded the overvoltage level. Detection level: 230V class—approx. 400V 460V class—approx. 800V 575V class—approx. 1000V | 1. Extend the deceleration time. 2. Check for proper DBU operation. 3. Check the resistor. 4. Check the line voltage. |
| OV (blinks) DC Bus Overvolt | Overvoltage Fault. Overvoltage occurs during stop. Main circuit DC voltage rises above the detection level while the drive output is off. Detection level: 410V or more for 230V, 820V or more for 460V and 1040V or more for 575V. | 1. Check the line voltage. |
| PF Input Pha Loss | Input Phase Loss Fault. Inverter input power supply has open phase. | 1. Check the line voltage. 2. Remove power. 3. Retighten the input terminal screws. |
| PGO PG Open | Pulse Generator Signal Missing Fault. The inverter detected a loss of encoder feedback. | 1. Check for proper direction of encoder feedback. 2. Please reference troubleshooting encoder related faults on page 6-12. |
| PGO2 PG Open 2 | Pulse Generator Signal Monitor Fault. This fault is set by either the encoder monitor or encoder backup function. | 1. Check for proper direction of encoder feedback. 2. Please reference troubleshooting encoder related faults on page 6-12. |

| Fault Code | Fault or Indicator Name/Description | Corrective Action |
|-------------------------------------|---|--|
| PUF DC Bus Fuse Open | DC Bus Fuse Open Fault. The DC fuse is open. | <ol style="list-style-type: none"> 1. Check for damaged transistor. 2. Check load-side short circuit. 3. Check grounding. <p><i>Do not replace an open DC bus fuse until the cause of failure has been corrected; non-warranty, damage to the drive may result. Refer to the "Power Section Check".</i></p> |
| RR DynBrk Transistr | Braking Transistor Fault. Internal Braking transistor failed. | <ol style="list-style-type: none"> 1. Verify that the external braking resistor is connected to the proper terminals. 2. Confirm that the proper resistor is installed. 3. Check for a short circuit across the braking resistor. |
| SC Short Circuit | Short Circuit Fault. The inverter has detected an output short circuit condition. | <ol style="list-style-type: none"> 1. Disconnect the motor from the inverter. 2. Check for a short circuit in the motor or wiring using a megger. |
| SLC Slack Cable Detection | Slack Cable Fault. A hoist slack cable condition occurred. | <ol style="list-style-type: none"> 1. May not require corrective action. 2. Check proper programming of Slack Cable Detection (C11-XX). |
| SVE Zero Servo Fault | Zero-Servo Fault. | <ol style="list-style-type: none"> 1. Check Zero-Servo sequence set-up. |
| SVR PG Quality | Noisy Encoder Fault. | <ol style="list-style-type: none"> 1. Check encoder and encoder wiring. 2. Increase B7-01. 3. Please reference troubleshooting encoder related faults on page 6-12. |
| UL1 Upper Limit 1 Err | Upper Limit 1—SLOW DOWN Indicator. Upper Limit 1—SLOW DOWN switch status is changed. | <ol style="list-style-type: none"> 1. May not require corrective action. 2. Check the limit switches location. 3. Check the limit switches condition. |
| UL2 Upper Limit 2 Err | Upper Limit 2—STOP Indicator. Upper Limit 2—STOP switch status is changed. | <ol style="list-style-type: none"> 1. May not require corrective action. 2. Check the limit switches location. 3. Check the limit switches condition. |
| UV DC Bus Undervolt | Undervoltage Fault. Undervoltage status occurs for more than 2 sec during STOP. Input voltage drops below 190V DC or less for 230V AC class, 380V DC or less for 460V AC class and 546V DC or less for 575V AC class. | <ol style="list-style-type: none"> 1. Check the power source wiring. 2. Replace any bad branch fuses. 3. Check collector system. |
| UV1 DC Bus Undervolt | Undervoltage 1 Fault. Undervoltage status occurs for more than 2 sec during RUN command. Input voltage drops below 190V DC or less for 230V AC class, 380V DC or less for 460V AC class and 546V DC or less for 575V AC class. | <ol style="list-style-type: none"> 1. Check power supply wiring. 2. Correct the line voltage. 3. Check collector system. |
| UV2 CTL PS Undervolt | Undervoltage 2 Fault. The inverter detected a loss of the 24V logic power supply voltage. This fault is only detected in inverters rated 2130-FVG+ through 2300-FVG+, 4128-FVG+ through 4605-FVG+ and 5027-FVG+ through 5200-FVG+. | <ol style="list-style-type: none"> 1. Check power supply wiring. 2. Correct the line voltage. 3. Check collector system. |
| UV3 MC Answerback | MC Fault. The pre-charge contactor opened during operation. | <ol style="list-style-type: none"> 1. Check power supply wiring. 2. Correct the line voltage. 3. Check collector system. 4. Wait 30-45 seconds before restarting drive after auto shut down. |

Troubleshooting Encoder Related Faults

The faults in this section may involve the encoder feedback system. During system startup, these faults are often caused by parameters that need to be adjusted. However, after the system has been running for some time without a fault, this usually indicates a problem with the physical system and adjusting the parameters should only be done after the physical system has been inspected.

Fault Code: Dev–Speed Deviation

Definition

Speed deviation faults mean that the drive output is not following the commanded speed reference. This is possible if there is not enough torque available to follow the internal speed reference. Therefore, speed deviations will typically occur when the drive is at its programmed torque limit. In addition, if the drive receives erratic, or missing, encoder pulses, speed deviations are also possible. If the initial drive tuning and start-up of the system was successfully completed and the crane has been in operation without any faults, then the occurrence of this fault most likely indicates that something mechanical with the system has changed or drive parameters were changed (i.e., failed encoder, load snag, crane overload, change in acceleration or deceleration times, etc.).

Corrective Action

1. Do **NOT** continue to operate the hoist.

NOTE: Continued attempts to operate the hoist with speed deviation faults occurring can result in loss of control of the load under certain circumstances.

2. As a precaution the load float time, parameter C8-10, should be set to zero until the source of the speed deviation fault has been determined and corrected.
3. Verify if the load has snagged or if there is a load on the hook that exceeds capacity.
4. Check the alignment of the encoder pulse wheel with the sensor head, or the encoder shaft coupling (depending on the type of encoder used). If the pulse wheel is misaligned or the shaft coupling is loose the drive will get erratic pulse signals or no signals at all causing a speed deviation fault or PGO (Pulse Generator Open) fault. Repairs to the encoder wheel or shaft coupling should be made immediately before again attempting to operate the hoist.
5. If the encoder appears to have no mechanical problems, the encoder cable should be checked for damage and replaced if a problem is found.
 - 5.1 Each of the encoder wires should be checked for continuity.
 - 5.2 The wires should be checked for shorts between any two wires.
 - 5.3 The wires should be checked for shorts to the shield or ground.
 - 5.4 Visually inspect the cable for damage that may be causing intermittent problems.
6. If the encoder feedback system checks out mechanically and electrically, then the last physical check to make is for something in the mechanical system that might be resisting normal operation. One example may be the brake is not opening fully and is causing enough drag to prevent the system from operating at commanded speed.

7. If the encoder feedback system checks out and no other mechanical problems can be found, then something must have changed in the control system.
 - 7.1 Check if the acceleration or deceleration times have been changed (B5-01, B5-02, or C1-02).
 - 7.2 Check if a function that provides an alternate acceleration or deceleration rate has been enabled or changed. (Quick Stop, Reverse Plug Simulation, Accel/Decel Time 2)If one of these times are too short, causing torque limited acceleration or deceleration, then the times should be extended.
8. If none of the above steps has identified a valid problem(s), only then should the speed deviation detection levels be adjusted.

NOTE: The reaction time necessary to stop a load is limited to the lift of the hoist and the response time of the hoist brakes. It is desirable to have as fast a fault reaction time as possible without causing nuisance trips.)
9. Increase Encoder Excessive Speed Deviation Level to no more than 30 (F1-10).
10. After the corrective action has been taken and the fault no longer occurs then the load float time, C8-10, can be set back to its initial value.

Fault Code: PGO–Pulse Generator Signal Missing

Definition

The pulse generator signal missing fault indicates that the drive has detected a loss of encoder feedback. This fault will typically occur if the drive doesn't receive any encoder feedback pulses while it is commanded to run.

Corrective Action

1. Do **NOT** continue to operate the hoist.

NOTE: Continued attempts to operate the hoist with PGO faults occurring can result in loss of control of the load under certain circumstances.
2. As a precaution, the load float time, parameter C8-10, should be set to zero until the source of the PGO Fault has been determined and corrected.
3. Check the alignment of the encoder pulse wheel with the sensor head, the encoder shaft coupling (depending on the type of encoder used), or check for a failed encoder sensor head. If one of these conditions exist the drive will get erratic pulse signals or no signal at all causing a speed deviation fault or PGO fault. Repairs to the encoder wheel or shaft coupling should be made immediately before again attempting to operate the hoist.
4. If the encoder appears to have no mechanical problems, the encoder cable should be checked for damage and replaced if a problem is found.
 - 4.1 Each of the encoder wires should be check for continuity.
 - 4.2 The wires should be checked for shorts between any two wires.
 - 4.3 The wires should be checked for shorts to the shield or ground.
 - 4.4 Visually inspect the cable for damage that may be causing intermittent problems.
5. If the encoder feedback system checks out, then check for physical obstruction to motor rotation such as brake failing to open.

6. After corrective action has been taken and the fault no longer occurs then the load float time, C8-10, can be set back to initial value.

Fault Code: PGO2–Pulse Generator Signal Monitor Fault

Definition

The Pulse Generator signal monitor fault indicates that the drive has detected a problem with the encoder. This fault may be generated by the encoder monitor function or the encoder backup function. In the encoder monitor function, if the motor shaft is told to move forward a number of pulses at a calculated frequency, the drive expects to see those counts forward in C8-21 time or less. If it does not, the drive sets a PGO2 Fault indicating a problem with the PG Circuit. In the encoder backup function, this fault is generated when the multi-function input has changed state and the encoder position has remained constant. Additionally this fault condition needs to be present for multiple consecutive changes in state of the multi-function input. The number of times required is set in F1-18.

Corrective Action

1. Do NOT continue to operate the hoist.

NOTE: Continued attempts to operate the hoist with PGO2 faults occurring can result in loss of control of the load under certain circumstances.

2. As a precaution, the load float time, parameter C8-10, should be set to zero until the source of the PGO fault has been determined and corrected.
3. Check the alignment of the encoder pulse wheel with the sensor head, the encoder shaft coupling (depending on the type of encoder used), or check for a failed encoder sensor head. If one of these conditions exist the drive will get erratic pulse signals or no signals at all causing a speed deviation fault or PGO fault. Repairs to the encoder wheel or shaft coupling should be made immediately before again attempting to operate the hoist.
4. If the encoder appears to have no mechanical problems, the encoder cable should be checked for damage and replaced if a problem is found.
 - 4.1 Each of the encoder wires should be checked for continuity.
 - 4.2 The wires should be checked for shorts between any two wires.
 - 4.3 The wires should be checked for shorts to the shield or ground.
 - 4.4 Visually inspect the cable for damage that may be causing intermittent problems.
5. If the encoder feedback system checks out, then check for a physical obstruction to motor rotation such as a brake failing to open.
6. If there is no physical problem detected, then adjust the parameters for the encoder monitor (C8-18–C8-21) or encoder backup function (F1-16–F1-18) as necessary.
7. After the corrective action has been taken and the fault no longer occurs then the load float time, C8-10, can be set back to its initial value.
8. It is possible that the parameter settings are such that the PGO2 function will not operate properly. In this case, disable the function.

Fault Code: SVR–Noisy Encoder Fault

Definition

Noisy encoder faults indicate that the drive has detected erratic encoder feedback. The drive continuously monitors the quality of the encoder feedback. If the encoder feedback exhibits erratic feedback for a period of time (set in B7-01) then this fault will be displayed.

Corrective Action

1. Do **NOT** Continue to operate the hoist.

NOTE: Continued attempts to operate the hoist with SVR faults occurring can result in loss of control of the load under certain circumstances.

2. As a precaution, the load float time, parameter C8-10, should be set to zero until the source of the SVR fault has been determined and corrected.
3. Check the alignment of the encoder pulse wheel with the sensor head, or the encoder shaft coupling (depending on the type of encoder used). If the pulse wheel is misaligned or the shaft coupling is loose the drive will get erratic pulse signals or no signals at all possibly causing an SVR fault. Repairs to the encoder wheel or shaft coupling should be made immediately before again attempting to operate the hoist.
4. If the encoder appears to have no mechanical problems, the encoder cable should be checked for damage and replaced if a problem is found.
 - 4.1 Each of the encoder wires should be checked for continuity.
 - 4.2 The wires should be checked for shorts between any two wires.
 - 4.3 The shield should be checked for proper grounding.
 - 4.4 The wires should be checked for shorts to the shield or ground.
 - 4.5 Visually inspect the cable for damage that may be causing intermittent problems.
5. If none of the above steps has identified a valid problem(s), only then should the SVR delay timer setting be adjusted.

NOTE: It is desirable to have as fast a fault no longer occurs then the load float time, C8-10, can be set back to its initial value.

6. After the corrective action has been taken and the fault no longer occurs then the load float time, C8-10, can be set back to its initial value.

Fault Code: BE1–Torque Proving Fault

Definition

The BE1 fault indicates that the drive has released the brake, but has not started to accelerate the motor when it detects more than the expected encoder feedback. A BE1 fault will occur if the pulses received during the BE1 detection time (C8-04) are greater than the expected number of pulses (C8-05). This is typically caused by the drive/motor have insufficient torque to suspend the load.

Correction Action

1. For reference, see timing diagram on page 5-40.
2. Check the encoder cable for damage and proper grounding. Replace it if a problem is found.
 - 2.1 Each of the encoder signals should be checked for excessive noise.
 - 2.2 The shielded encoder cable should be properly grounded.
 - 2.3 Visually inspect the cable for damage that may be causing intermittent problems.
3. Check the alignment of the encoder pulse wheel with the sensor head, or the encoder shaft coupling (Depending on the type of encoder used). If the pulse wheel is misaligned or the shaft coupling is loose the drive may get erratic pulse signals possibly causing a BE1 fault. Repairs to the encoder wheel or shaft coupling should be made immediately before again attempting to operate the hoist.
4. If none of the above steps has identified a valid problem(s), only then should the BE1 detection parameters be adjusted.

NOTE: It is desirable to have as fast a fault reaction time as possible without causing nuisance trips.

5. Increase C8-05 to no more than 800.

Fault Code: BE3–Brake Release Fault

Definition

The BE3 fault indicates that the drive has released the brake and commanded the drive to run, but has not detected the expected encoder feedback. A BE3 fault will occur if the pulses received during the BE3 detection time (C8-06) are less than the expected number of pulses (C8-07).

NOTE: Depending on the condition of the crane and control system, the load may drift during the BE3 detection time until the brake is again set. If giving a run command, the BE3 fault should be detected before a PGO fault would be detected.

Corrective Action

1. For reference, see timing diagram on page 5-41.
2. Check the brake for proper operation. If the brake does not open the drive will not see the proper number of encoder pulses returned and will post this fault.
3. Check the alignment of the encoder pulse wheel with the sensor head, or the encoder shaft coupling (depending on the type of encoder used). If the pulse wheel is misaligned or the shaft coupling is loose the drive will get erratic pulse signals or no signals at all possibly causing a BE3 fault. Repairs to the encoder wheel or shaft coupling should be made immediately before again attempting to operate the hoist.

4. If the encoder appears to have no mechanical problems, the encoder cable should be checked for damage and replaced if a problem is found.
 - 4.1 Each of the encoder wires should be checked for continuity.
 - 4.2 The wires should be checked for shorts between any two wires.
 - 4.3 The wires should be checked for shorts to the shield or ground.
 - 4.4 Visually inspect the cable for damage that may be causing intermittent problems.
5. If none of the above steps has identified a valid problem(s), only then should the BE3 detection parameters be adjusted.

NOTE: It is desirable to have as fast a fault reaction time as possible without causing nuisance trips.
6. Ensure that C8-04 is equal to the brake's mechanical delay time.
7. Increase the value of C8-06 to no more than 1 second.
8. Decrease the value of C8-07 to no less than 10.

Fault Code: BE6—Brake Proving Alarm

Definition

The BE6 alarm indicates that the drive has commanded the brake to set but it has detected more than the expected encoder feedback. A BE6 alarm will occur if the number of pulses received during the BE6 detection time (C8-12) is greater than the expected number of pulses (C8-13).

NOTE: This fault typically indicates a failed brake. Power should NOT be removed while this fault is active and the load should be moved to a safe location and lowered before proceeding with any corrective action.

Corrective Action

1. For reference, see timing diagram on page 5-43.
2. Check the brake for proper operation and adjustment. If the brake does not set, is improperly adjusted or is excessively worn, it may not be able to hold the load. This will allow the encoder pulses received during the detection time to exceed the set point.
3. Check the encoder cable for damage and proper grounding. Replace it if a problem is found.
 - 3.1 Each of the encoder signals should be checked for excessive noise.
 - 3.2 The shielded encoder cable should be properly grounded.
 - 3.3 Visually inspect the cable for damage that may be causing intermittent problems.
4. Check the alignment of the encoder pulse wheel with the sensor head, or the encoder shaft coupling (Depending on the type of encoder used). If the pulse wheel is misaligned or the shaft coupling is loose the drive may get erratic pulse signals possibly causing a BE6 fault. Repairs to the encoder wheel or shaft coupling should be made immediately before again attempting to operate the hoist.
5. If none of the above steps has identified a valid problem(s), only then should the BE6 detection parameters be adjusted.

NOTE: It is desirable to have as fast a fault reaction time as possible without causing nuisance trips.

6. Ensure that C8-11 is equal to the brake's mechanical delay time.
7. Increase the value of C8-13.

Fault Code: OC–Over Current Fault

Definition

An over current fault is caused if the output current exceeds 200% of the inverter rated output current. This fault can be caused by short circuits in the wiring or in the motor, and it can also be caused by parameters that are not adjusted properly. One other cause of this alarm could be erratic or no encoder feedback. In the last instance, the drive is trying to command the motor to hold a position but due to the encoder problem, is unable to find the correct position. This would cause the drive to increase current output to the motor in an attempt to correct the position until an over current fault occurs.

Corrective Action

1. Check the motor wiring and the motor itself for a short between phases.
2. Check the alignment of the encoder pulse wheel with the sensor head, or the encoder shaft coupling (depending on the type of encoder used). If the pulse wheel is misaligned or the shaft coupling is loose the drive will get erratic pulse signals or no signals at all possibly causing an OC fault. Repairs to the encoder wheel or shaft coupling should be made immediately before again attempting to operate the hoist.
3. If the encoder appears to have no mechanical problems, the encoder cable should be checked for damage and replaced if a problem is found.
 - 3.1 Each of the encoder wires should be check for continuity.
 - 3.2 The wires should be checked for shorts between any two wires.
 - 3.3 The shield should be check for proper grounding.
 - 3.4 The wires should be checked for shorts to the shield or ground.
 - 3.5 Visually inspect the cable for damage that may be causing intermittent problems.
4. If none of the above steps has identified a valid problem(s), check if any of the torque limit parameters (C7-01 to C7-04) have been changed. If these parameters have been changed to allow a higher torque value, it could cause over current trips.

NOTE: Changing these parameters could also induce speed deviation or overload faults. Only a trained technician should modify these parameters. It is desirable to have as fast a fault reaction time as possible without causing nuisance trips.

Fault Display and Corrective Actions at Auto-tuning

The following are fault displays and corrective actions at auto-tuning. If any of the following faults are found, the digital operator displays that fault contents; the motor coasts to stop if it is under operation. Fault contact output or minor fault contact output does not operate. For further information see Auto Tuning page 4-16 and Factory Tuning Section page 5-67.

| Fault Display | Fault or Indicator Name/Description | Corrective Action |
|---|---|---|
| Data Invalid (Motor data fault) | Motor data fault. Invalid motor data. | <ol style="list-style-type: none"> 1. Verify input data. 2. Verify motor/drive capacities. 3. Change the settings to conform to the following equation: Rated speed < 120 x Motor frequency/ number of poles |
| Resistance (Line-to-line resistance fault) | Terminal resistance fault. Tuning was not completed within the specified time. | |
| No-Load Current | No-Load Current fault. Tuning was not completed within the specified time. | |
| Saturation-1 | Iron core saturation coefficient 1 fault. The core saturation coefficient was not completed within the specified time. | <ol style="list-style-type: none"> 1. Incorrect rated current setting 2. Check for loose/broken or disconnected motor wire |
| Saturation-2 | Iron core saturation coefficient 2 fault. the core saturation coefficient was not completed within the specified time. | |
| Rated Slip | Rated Slip Fault. Rated slip setting was not completed within the specified time. | <ol style="list-style-type: none"> 1. Verify that the motor is de-coupled from load. |
| Accelerate | Acceleration fault. Motor does not accelerate in specified time. | <ol style="list-style-type: none"> 1. Verify the brake is released (manually). 2. Increase acceleration time (B5-01). 3. Verify that the motor is de-coupled from load. 4. Verify that C7-01, -02 = 150%. |
| PG Direction | Motor rotating direction fault. | <ol style="list-style-type: none"> 1. Change F1-05 2. Swap T1 and T2 motor leads. 3. Check the PG wiring. 4. Check the motor wiring. |
| Motor Speed | Motor Speed Fault. Torque reference becomes excessive (100%) during tuning. | <ol style="list-style-type: none"> 1. Verify that the brake is released (manually). 2. Increase acceleration time B5-01. 3. Verify that the motor is de-coupled from load. |
| Alarm: Overload (Displayed after completion of turning) | Excessive tuning load. Torque reference exceeded 20% at tuning | <ol style="list-style-type: none"> 1. Verify that the motor is de-coupled from load. 2. Turn the power off and rotate the motor shaft by hand. Replace motor if it does not turn smoothly. |

Troubleshooting CDBR Faults

| Fault Status | Possible Cause | Corrective Action |
|---|--|---|
| Drive trips at overvoltage (OV) | <ul style="list-style-type: none"> • Insufficient braking unit capacity • Insufficient resistor capacity • Improper wiring • Deceleration time too short • Braking unit fault | <ol style="list-style-type: none"> 1. Verify CDBR capacity 2. Verify resistor capacity 3. Verify wiring is correct 4. Lengthen deceleration time 5. Replace the braking unit |
| Braking Unit Thermal Overload trips when not decelerating | <ul style="list-style-type: none"> • Improper braking unit power supply voltage selection setting • Incoming (line) voltage too high • Discharge transistor shorted | <ol style="list-style-type: none"> 1. Verify Jumper setting 2. Correct Line Voltage 3. Replace the braking unit |
| Braking Unit trips by heatsink overheat | <ul style="list-style-type: none"> • Excessive load inertia • Improper combination of braking unit and resistor • Ambient temperature > 113°F | <ol style="list-style-type: none"> 1. Reduce load 2. Verify proper braking unit/resistor 3. Install air conditioner |

Power Section Check



WARNING

Do NOT touch any circuit components while AC main power is on or immediately after the main AC power is disconnected from the unit. You must wait until the red “CHARGE” lamp is extinguished. It may take as long as 10 minutes for the charge on the main DC bus capacitors to drop to a safe level. Failure to adhere to this warning could result in serious injury.

Power Off Checks

To perform a power section check, remove the drives main and control wiring from the terminal strips. Obtain reading as specified in the table on the next page, and ensure that the reading falls within the normal reading range.

Test equipment - Analog Ohmmeter set R x 1 scale or digital multimeter set to the diode check.

| Device | VOM (on RX1 Scale) | | Normal Reading (Analog Meter) | Normal Reading (Digital Meter) |
|---|--------------------|----------------------|--|--|
| | Positive Lead | Negative Lead | | |
| Input Rectifier Bridge *1 | L1 | + | 7–100Ω | Approximately 0.5 V |
| | L2 | + | | |
| | L3 | + | | |
| | – | L1 | | |
| | – | L2 | | |
| | – | L3 | | |
| | L1 | – | Infinite Ω | OL Displayed |
| | L2 | – | | |
| | L3 | – | | |
| | + | L1 | | |
| | + | L2 | | |
| | + | L3 | | |
| Bus Capacitors | + | – | Observe gradually increasing resistance | Observe gradually increasing voltage to OL |
| Pre-charge Resistor | – | Across the Resistors | 100 Ω or less | – |
| Output Transistors *2 *3 | T1 | + | 7-100 Ω | Approximately 0.5V |
| | T2 | + | | |
| | T3 | + | | |
| | – | T1 | | |
| | – | T2 | | |
| | – | T3 | | |
| | T1 | – | Infinite Ω | OL Displayed |
| | T2 | – | | |
| | T3 | – | | |
| | + | T1 | | |
| | + | T2 | | |
| | + | T3 | | |
| Braking Diode (2006–2033) (4001–4034) | B2 | B1 | 10 Ω | 0.5 V |
| | B1 | B2 | Infinite Ω | OL Displayed |
| | B2 | – | Infinite Ω | OL Displayed |
| | – | B2 | Infinite Ω | OL Displayed |

*1. “+” could be any one of three (+) terminals which are labeled as ⊕1, ⊕2, and ⊕3.

*2. If the bus fuse is blown you must install a jumper across the fuse terminals to get accurate resistance measurements.

*3. If the pre-charge resistor is open, you will read infinite Ω between + and any output terminal unless you install a temporary jumper across the resistor.

Braking Circuit

Test Equipment - Analog Ohmmeter set to R X 1 scale or digital multimeter set to the diode check.

| Step No. | Ohmmeter Positive Lead | Ohmmeter Negative Lead | Expected Reading (Analog Meter) | Expected Reading (Digital Meter) |
|----------|------------------------|------------------------|---------------------------------|----------------------------------|
| 1 | Connect to B2 | Connect to B1 | 10 Ohms | 0.5 Volts |
| 2 | Connect to B1 | Connect to B2 | Infinite Ohms | 0L displayed |
| 3 | Connect to B2 | – | Infinite Ohms | 0L displayed |
| 4 | – | Connect to B2 | Infinite Ohms | 0L displayed |

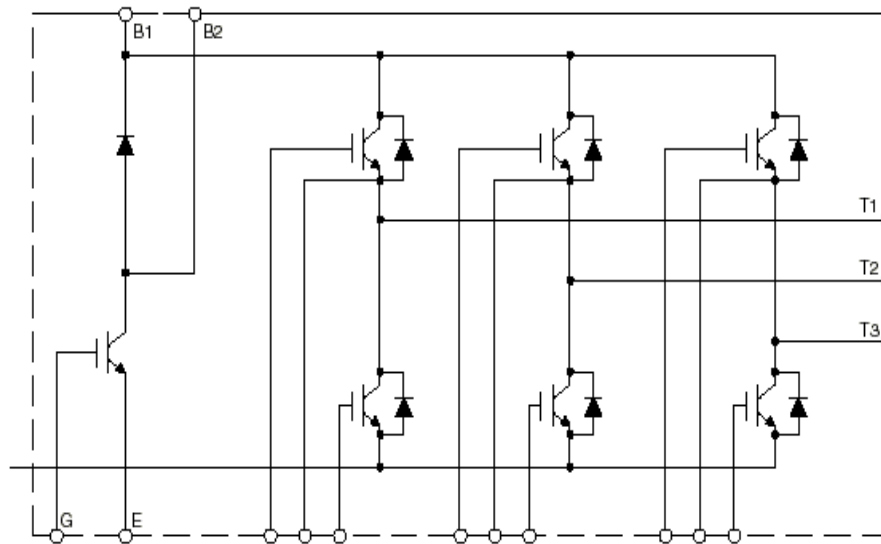

Figure 6-1

This page intentionally left blank.

A p p e n d i x **A**

Servicing
IMPULSE•VG+ Series 2

This page intentionally left blank.

Service

This chapter includes information pertaining to on-call service, drive identification, troubleshooting, and warranty. Before you install, troubleshoot, or service the drive, we highly recommend that you read this entire chapter. Doing this will help assure quick service response, minimize your on-site repair costs, and reduce crane downtime.

Your *IMPULSE•VG+* Series 2 drive includes a two-year warranty from date of shipment. The warranty is described in detail later in this chapter.

On-Call Service

If you ever require our assistance, contact us at (800) 288-8178; our fax number is (800) 298-3508. Technical support is available 24 hours a day, seven days a week, and 365 days a year. If necessary, we can arrange to have a Service Technician visit your site to evaluate the situation.

Identifying Your Drive

If you ever have to contact Electromotive Systems about your drive, first determine the model and serial numbers of your drive by looking at the nameplate shown below.

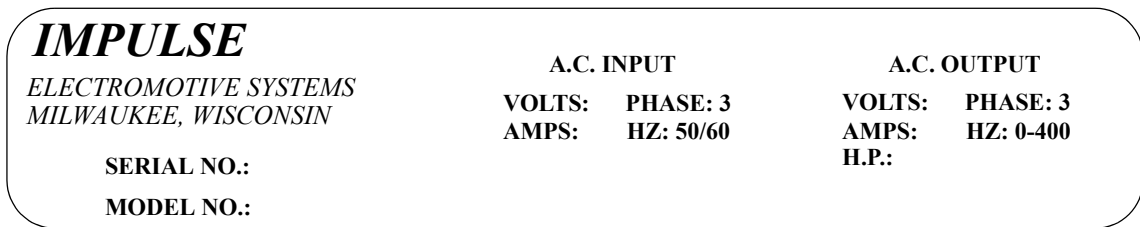

Figure 6.1

This nameplate is normally located on the side of the drive nearest to the keypad.

Service Policy For Small Drives, DBUs, and Other Electrical Components

This section explains Electromotive Systems' service policy for the small drives (2006-FVG+ through 2224-FVG+ and 4001-FVG+ through 4165-FVG+ and 5003-FVG+ through 5099-FVG+), dynamic braking units (DBUs), and other electrical components.

Should your *IMPULSE* product fail during the warranty period, Electromotive Systems will repair or replace your unit within 72 hours (3 working days). In most cases, we can supply a replacement unit within 24 hours (1 working day). If the problem is not covered under warranty, you are responsible for the cost of the repairs and the shipping charges.

To return a failed unit (or part):

1. Request a Return Authorization (RA) from Electromotive Systems' Service Department, as a condition for us to repair or replace the unit. Return the failed unit to Electromotive Systems **via pre-paid freight**. When you call, please have the serial number of the drive available and be prepared to provide the information requested on the Return Authorization Information Sheet found on page A-5.
2. A purchase order or credit card is required to cover the cost of the replacement unit or repairs to a returned unit.

Electromotive Systems will inspect the failed unit and determine if the unit is covered under warranty.

- If the unit is covered under warranty, Electromotive Systems will credit the cost of the replacement unit and/or repairs and reimburse for all reasonable freight charges.

NOTE: Freight charges incurred from sources other than common ground carriers WILL NOT be reimbursed unless pre-approved by Electromotive Systems.

- If the unit is not covered under warranty, Electromotive Systems will bill you for the cost of the replacement unit or the cost of repairs. Electromotive Systems will also bill you for a \$125.00 inspection fee (this fee will be waived if repairs are made to the unit) and any freight charges incurred by Electromotive Systems.

Service Policy for Large Drives

This section explains Electromotive Systems' service policy for the large drive (2300-FVG+, and 4224-FVG+ through 4605-FVG+, and 5130-FVG+ through 5200-FVG+).

Because of the size and weight of large units, it may not be practical to return the entire drive to Electromotive Systems for repair. If a drive has failed, you must first contact us by telephone for assistance in diagnosis. If necessary, we may authorize the on-site replacement of specific components and the return of these failed parts for credit, replacement, or repair.

These components include; but not limited to:

- Control/logic card
- Main base drive card
- Subbase drive card
- Drive unit transistor cassette
- Fan unit
- Main input diode circuit
- Capacitors
- DC Bus Fuses
- Electromotive Systems interface and special option cards.

On-site troubleshooting and the replacement of failed components is to be performed only by technicians approved by Electromotive Systems.

Follow procedures outlined above for returning components.

Electromotive Systems Limited Warranty

Magnetek Electromotive Systems, hereafter referred to Company, guarantees all items manufactured by it against any defects of material and/or workmanship for a period of two years for the date of shipment. Company makes NO OTHER WARRANTY, EXPRESSED OR IMPLIED, AS TO THE MERCHANTABILITY OR FITNESS OF THE ITEMS FOR THEIR INTENDED USE OR AS TO THEIR PERFORMANCE. Any statement, description or specification in Company's literature is for the sole purpose of identification of items sold by the Company and imparts no guarantee, warranty or undertaking by company of any kind. Components and accessories not manufactured by Magnetek Electromotive Systems are not included in this warranty and are warranted separately by their respective manufacturers.

Company's sole liability shall be to repair at its factory, or replace any item returned to it within two years for date of shipment, which Company finds to contain defective material or workmanship. All items to be repaired or replaced shall be shipped to Company (Note: return authorization by Company is required) within said two year period, freight prepaid, as a condition to repair or replace defective material or workmanship. Company's herein assumed responsibility does no cover defects resulting from improper installation, maintenance, or improper use. Any corrective maintenance performed by anyone other than the Company during the warranty period shall void the warranty. Company shall not be liable for damages of any kind from any cause whatsoever beyond the price of the defective Company supplied items involved. Company shall not be liable for economic loss, property damage, or other consequential damages or physical injury sustained by the purchaser or by any third party as a result of the use of any Company supplied items or material.

Company neither assumes nor authorizes any other person to assume for company any other liability in connection with the sale or use of items sold by Company.

List prices or discounts are subject to change without notice. Quoted prices will be honored for a period of 30 days form the date of the written quotation unless otherwise stated.

Orders of \$25,000 or more, and orders for special control panels are subject to special terms and conditions of sale. Refer to those specific sections within this document.

Orders are not subject to alteration or cancellation except upon written consent of Company and payment of proper cancellation charges, when deemed applicable by Company.

Materials or items may not be returned for credit, without the prior written consent of the Company. Any authorized return of materials or items shall be subject to a restocking charge equal to 20% of the net invoiced amount after Company determines that the material or items is in good condition and may be resold without alteration or service.

Terms of payment are NET 30 days. All materials and items are sold F.O.B. Company's shipping point. Company retains a security interest in all items sold by it so long as they remain in Company's possession to secure all obligations of purchaser to Company. A processing fee will be applied to all invoices for requested prepaid freight charges other than UPS. A service charge will be incurred on past due accounts extending beyond the terms of sale described above, at a rate of 1.5% per month of the net balance extending beyond 30 days.

Any claim for material or item shortages must be received by Company within 30 days of shipment and must be accompanied by copies of the bill of lading and packing slip.

This page left intentionally blank.

IMPULSE•VG+ Series 2 Parameter Listing

| No. | Parameter Name | Factory Default | Ref Page# |
|----------------|----------------------------|-----------------|-----------|
| A1-01 | Access Level | 2 | 4-9 |
| A1-02 | Control Method | 3 | 4-9 |
| A1-03 | Motion | 0 or 2 | 4-10 |
| A1-04 | Speed Ref | 6 | 4-10 |
| A1-05 | Unit Parameters | 0 | 4-15 |
| A1-06 | Password 1 | 0 | 4-15 |
| A1-07 | Select Password 1 | 0 | 4-15 |
| A2-01 to A2-30 | User Parameters | --- | 4-15 |
| B1-01 | Reference 1 | 15 | 5-3 |
| B1-02 | Reference 2 | 30 | 5-3 |
| B1-03 | Reference 3 | 60 | 5-3 |
| B1-04 | Reference 4 | 45 | 5-3 |
| B1-05 | Reference 5 | 60 | 5-3 |
| B1-06 | Reference 6 | 0.0 | 5-3 |
| B1-07 | Reference 7 | 0.0 | 5-3 |
| B1-08 | Reference 8 | 0.0 | 5-3 |
| B1-09 | Jog Reference | 6 | 5-3 |
| B1-10 | Ref Priority | 0 | 5-3 |
| B2-01 | Ref Upper Limit | 100.0 | 5-5 |
| B2-02 | Ref Lower Limit | 2 | 5-5 |
| B2-03 | Upper Limit Gain | 100 | 5-5 |
| B3-01 | Reference Source | 1 | 5-6 |
| B3-02 | Run Source | 1 | 5-6 |
| B3-03 | Stopping Method | * | 5-7 |
| B3-05 | Zero-Speed Operation | 0 | 5-9 |
| B3-06 | Control Input Scans | 1 | 5-13 |
| B3-07 | Local/Remote Run Select | 0 | 5-13 |
| B4-02 | Trim Control Level | 10 | 5-13 |
| B5-01 | Acceleration Time 1 | 5.0 | 5-14 |
| B5-02 | Deceleration Time 1 | 3.0 | 5-15 |
| B5-03 | Acceleration Time 2 | 1.0 | 5-15 |
| B5-04 | Deceleration Time 2 | 1.0 | 5-15 |
| B5-05 | Acceleration Time N Change | 1.0 | 5-16 |
| B5-06 | Deceleration Time N Change | 1.0 | 5-16 |
| B5-07 | Hoist 2 Stop Decel | 0.3 | 5-16 |
| B5-08 | Fault Stop Time | 0.3 | 5-16 |
| B5-09 | Accel/Decel Units | 1 | 5-16 |
| B5-10 | Accel/Decel Switch Freq | 120.0 | 5-16 |
| B5-11 | Switch Freq Compare | 1 | 5-16 |

| No. | Parameter Name | Factory Default | Ref Page# |
|------------|--------------------------------|------------------------|------------------|
| B5-12 | Forward Torque Limit Accel | 0 | 5-18 |
| B5-13 | Forward Torque Limit Decel | 0 | 5-18 |
| B5-14 | Reverse Torque Limit Accel | 0.5 | 5-18 |
| B5-15 | Reverse Torque Limit Decel | 0 | 5-18 |
| B6-01 | Phase Loss Input Select | 0 | 5-19 |
| B6-02 | Phase Loss Input Level | 7.5 | 5-19 |
| B6-03 | Phase Loss Output Select | 1 | 5-19 |
| B6-04 | Phase Loss Output Level | 5.0 | 5-19 |
| B7-01 | SVR Delay Timer | 70 | 5-19 |
| B8-01 | Jump Frequency 1 | 0 | 5-20 |
| B8-02 | Jump Frequency 2 | 0 | 5-20 |
| B8-03 | Jump Frequency 3 | 0 | 5-20 |
| B8-04 | Jump Bandwidth | 1.0 | 5-20 |
| C1-01 | Quick Stop Enable/Disable | 0 | 5-22 |
| C1-02 | Quick Stop Time | 1.0 | 5-22 |
| C1-03 | Reverse Plug Enable/Disable | 0 | 5-23 |
| C1-04 | Reverse Plug Decel Time | 1.0 | 5-23 |
| C1-05 | Reverse Plug Accel Time | 1.0 | 5-23 |
| C2-01 | Micro Speed Gain 1 | 1.00 | 5-24 |
| C2-02 | Micro Speed Gain 2 | 1.00 | 5-24 |
| C3-01 | Upper Limit 1 Speed | 6 | 5-25 |
| C3-02 | Upper Limit 1 Decel Time | 1.0 | 5-25 |
| C3-03 | Upper Limit 2 Decel Time | 1.0 | 5-25 |
| C3-04 | Lower Limit 1 Speed | 6 | 5-25 |
| C3-05 | Lower Limit 1 Decel Time | 1.0 | 5-25 |
| C3-06 | Lower Limit 2 Decel Time | 1.0 | 5-25 |
| C3-07 | Action @ LL2/UL2 | 0 | 5-25 |
| C4-01 | Zero Servo Timer | 10 | 5-27 |
| C4-02 | Zero Servo Gain | 10/20 or 25/50 | 5-27 |
| C4-03 | Zero Servo Count | 10 | 5-27 |
| C5-01 | Load Check Enable/Disable | 0 | 5-28 |
| C5-02 | Load Check Alarm Action | 1 | 5-28 |
| C5-03 | Min Torque Reference | 60% | 5-28 |
| C5-04 | Look Speed 1 | 6 | 5-28 |
| C5-06 | Vector Torque Reference | 125 | 5-28 |
| C5-07 | Look Speed 2 | 20 | 5-28 |
| C5-09 | Look Speed 3 | 60 | 5-28 |
| C5-11 | Current Ref for > Look Speed 3 | 160 | 5-28 |
| C5-12 | Load Check Setting Time | 0.20 | 5-28 |
| C5-13 | Load Check Test Time | 0.10 | 5-28 |
| C5-14 | Load Check Fault Speed | 6 | 5-28 |
| C6-01 | Ultra Lift Enable/Disable | 0 | 5-30 |

| No. | Parameter Name | Factory Default | Ref Page# |
|------------|----------------------------------|------------------------|------------------|
| C6-02 | Ultra Lift Forward Speed | 60 | 5-30 |
| C6-03 | Ultra Lift Reverse Speed | 60 | 5-30 |
| C6-04 | Ultra Lift Forward Torque | 50 | 5-30 |
| C6-05 | Ultra Lift Reverse Torque | 30 | 5-30 |
| C6-06 | Ultra Lift Enabling Speed | 60 | 5-30 |
| C6-07 | Ultra Lift Delay Time | 2.0 | 5-30 |
| C6-08 | SFS Acceleration Gain | 1.0 | 5-30 |
| C7-01 | Forward Torque Limit | 150 | 5-32 |
| C7-02 | Reverse Torque Limit | 150 | 5-32 |
| C7-03 | Forward Regen Torque Limit | 180 | 5-32 |
| C7-04 | Reverse Regen Torque Limit | 180 | 5-32 |
| C7-07 | Torque Limit Gain by MFI | 1.25 | 5-32 |
| C8-01 | Torque Compensation Time | 1.50/2.50 | 5-34 |
| C8-02 | Current Feedback OK Timer | 1.50/2.50 | 5-34 |
| C8-03 | Minimum Brake Release Torque | 10 | 5-34 |
| C8-04 | Roll Back/BE4 Timer | 0.70 | 5-34 |
| C8-05 | Roll Back Count | 400 | 5-34 |
| C8-06 | BE3/Alternate Rev Torque Time | 0.50 | 5-34 |
| C8-07 | BE3 Detect Count | 50 | 5-34 |
| C8-08 | Alternate Reverse Torque Limit | 10 | 5-34 |
| C8-09 | Zero Speed Level | 1 | 5-34 |
| C8-10 | Load Float Time | 10 | 5-34 |
| C8-11 | Brake Delay Time/BE5 Timer | 0.7 | 5-34 |
| C8-12 | BE6 Detect Time | 5.0 | 5-34 |
| C8-13 | BE6 Maximum Count | 250 | 5-34 |
| C8-15 | Load Float Extension Time by MFI | 10 | 5-34 |
| C8-16 | Initial Brake Release Torque | 100 | 5-35 |
| C8-17 | BE6 Up Speed | 6.00 | 5-35 |
| C8-18 | Load Float PG Moni | 0 | 5-35 |
| C8-19 | PG Moni Count | 20 | 5-36 |
| C8-20 | Shaft Osc. Gain | 15 | 5-37 |
| C8-21 | PG Monitor Fault Time | 1.00 | 5-37 |
| C9-01 | G5IN4 Enable/Disable | 0 | 5-45 |
| C9-02 | G5IN4 Setup | 0 | 5-45 |
| C10-01 | Load Weight Enable/Disable | 0 | 5-49 |
| C10-02 | Torque Output Primary Delay | 200 | 5-49 |
| C10-03 | Load Weight Display Hold | 0 | 5-49 |
| C10-04 | Load Weight Conversion | 0 | 5-49 |
| C10-05 | Full Load Torque Output | 100.0 | 5-49 |
| C10-06 | No Load Torque Output | 0 | 5-49 |
| C10-07 | Line 2 Display | 0 | 5-49 |
| C11-01 | Slack Cable Enable/Disable | 0 | 5-52 |
| C11-02 | Action at Slack Cable | 2 | 5-52 |

| No. | Parameter Name | Factory Default | Ref Page# |
|------------|------------------------------|------------------------|------------------|
| C11-03 | Slack Cable Detection Torque | 30 | 5-53 |
| C11-04 | Slack Cable Detect Speed 1 | 2 | 5-53 |
| C11-05 | Slack Cable Delay Time 1 | 0.50 | 5-53 |
| C11-06 | Slack Cable Detect Speed 2 | 60 | 5-53 |
| C11-07 | Slack Cable Delay Time 2 | 0.10 | 5-53 |
| C12-01 | Brake Jog Delay | 0.0 | 5-54 |
| C12-02 | Brake Run Delay | 1.1 | 5-54 |
| C12-03 | Delay-ON Timer | 0.0 | 5-54 |
| C12-04 | Delay-OFF Timer | 0.0 | 5-54 |
| C13-01 | Inch Run Time | 1.00 | 5-55 |
| C13-02 | Repeat Delay T | 1.00 | 5-55 |
| D1-01 | DC Injection Start Frequency | 1.5 | 5-56 |
| D1-03 | DC Injection Time @ Start | 0.00 | 5-56 |
| D1-04 | DC Injection Time @ Stop | 0.05 | 5-56 |
| D1-05 | DC Injection P Gain | 0.05 | 5-56 |
| D1-06 | DC Injection Integral Time | 100 | 5-56 |
| D1-07 | DC Injection | 15.0 | 5-56 |
| D2-01 | Slip Compensation Gain | 1 | 5-58 |
| D4-01 | ASR P Gain 1 | 30 | 5-58 |
| D4-02 | ASR I Time 1 | 0.500 | 5-58 |
| D4-03 | ASR P Gain 2 | 30 | 5-59 |
| D4-04 | ASR I Time 2 | 0.100 | 5-59 |
| D4-06 | ASR Delay Time | 0.004 | 5-59 |
| D4-07 | ASR Gain Switch Frequency | 0.0 | 5-59 |
| D4-08 | ASR I Limit | 400 | 5-59 |
| D5-01 | Torque Control Select | 0 | 5-59 |
| D5-02 | Torque Reference Filter | 0 | 5-60 |
| D5-03 | Speed Limit Select | 1 | 5-60 |
| D5-04 | Speed Limit Value | 0 | 5-60 |
| D5-05 | Speed Limit Bias | 10 | 5-60 |
| D5-06 | Reference Hold Time | 0 | 5-60 |
| D6-01 | Droop Quantity | 0 | 5-62 |
| D6-02 | Droop Delay Time | 0.05 | 5-62 |
| D8-01 | Dwell Reference @ Start | 0 | 5-63 |
| D8-02 | Dwell Time @ Start | 0 | 5-63 |
| D8-03 | Dwell Reference @ Stop | 0 | 5-63 |
| D8-04 | Dwell Time @ Stop | 0 | 5-63 |
| D9-01 | S-Curve Accel @ Start | 0.0 | 5-64 |
| D9-02 | S-Curve Accel @ End | 0.0 | 5-64 |
| D9-03 | S-Curve Decel @ Start | 0.0 | 5-64 |
| D9-04 | S-Curve Decel @ Stop | 0 | 5-64 |
| D10-01 | Carrier Frequency Max | 3 | 5-66 |
| D12-30 | Carrier in Tune | 0 | 5-67 |

| No. | Parameter Name | Factory Default | Ref Page# |
|------------|------------------------------|------------------------|------------------|
| E1-01 | Input Voltage | 230/460 | 5-68 |
| E1-02 | Motor Selection | 1 | 5-69 |
| E1-03 | V/F Selection | F | 5-69 |
| E1-04 | Max Frequency | 60.0 | 5-69 |
| E1-05 | Max Voltage | 230/460 | 5-69 |
| E1-06 | Base Frequency | 60 | 5-69 |
| E1-09 | Min Frequency | 0.0 | 5-69 |
| E1-11 | Mid Frequency B | 0.0 | 5-69 |
| E1-12 | Mid Voltage B | 0.0 | 5-69 |
| E1-13 | Base Voltage | 0.0 | 5-69 |
| E2-01 | Motor Rated Full Load Amps | --- | 5-70 |
| E2-02 | Motor Rated Slip | --- | 5-70 |
| E2-03 | No load current | --- | 5-70 |
| E2-04 | Number of Poles | 4 | 5-70 |
| E2-05 | Terminal Resistance | --- | 5-70 |
| E2-06 | Leakage Inductance | --- | 5-70 |
| E2-07 | Saturation Compensation 1 | --- | 5-70 |
| E2-08 | Saturation Compensation 2 | --- | 5-70 |
| E2-09 | Mechanical Loss | --- | 5-70 |
| E3-01 | Motor 2 Control Method | 2 | 5-71 |
| E3-02 | Motion 2 | 1 | 5-71 |
| E4-01 | V/F 2 Max Frequency | 60 | 5-71 |
| E4-02 | V/F 2 Max Voltage | 230/460 | 5-71 |
| E4-03 | V/F 2 Base Frequency | 60 | 5-71 |
| E4-04 | V/F 2 Mid Frequency | 3.0 | 5-71 |
| E4-05 | V/F 2 Mid Voltage | 12.6 | 5-71 |
| E4-06 | V/F 2 Min Frequency | 0.5 | 5-71 |
| E4-07 | V/F 2 Min Voltage | 2.3 | 5-71 |
| E5-01 | Motor 2 Rated Full Load Amps | --- | 5-72 |
| E5-02 | Motor 2 Rated Slip | --- | 5-72 |
| E5-03 | Motor 2 No Load Current | --- | 5-72 |
| E5-05 | Motor 2 Terminal Resistance | --- | 5-72 |
| E5-06 | Motor 2 Leakage Inductance | --- | 5-72 |
| F1-01 | PG Pulses/Revolution | 1024 | 5-73 |
| F1-02 | PG Feedback Loss Select | 1 | 5-72 |
| F1-03 | PG OverSpeed Select | 1 | 5-73 |
| F1-04 | Action @ PG Deviation Select | 1 | 5-73 |
| F1-05 | PG Rotation Select | 0 | 5-73 |
| F1-06 | PG Output Ratio | 1 | 5-73 |
| F1-07 | PG Ramp PI/I Select | 0 | 5-74 |
| F1-08 | PG OverSpeed Level | 115 | 5-74 |
| F1-09 | PG OverSpeed Time | 0.0 | 5-74 |
| F1-10 | PG Deviate Level | 10 | 5-74 |

| No. | Parameter Name | Factory Default | Ref Page# |
|------------|--|------------------------|------------------|
| F1-11 | PG Deviate Time | 0.3 | 5-74 |
| F1-12 | SFS Deviate | 120.0 | 5-74 |
| F1-13 | PG # Gear Teeth 1 | 0 | 5-74 |
| F1-14 | PG # Gear Teeth 2 | 0 | 5-74 |
| F1-15 | PGO Detect Time | 0.3 | 5-74 |
| F1-16 | Pulse PPR | 1 | 5-74 |
| F1-17 | Pulse Enable Spd | 10.0 | 5-74 |
| F1-18 | MFI Fault Buffer | 3 | 5-74 |
| F2-01 | AI-14 Input Select | 0 | 5-75 |
| F3-01 | Digital Input Setup | 0 | 5-76 |
| F4-01 | Analog Out Channel 1 Select | 2 | 5-77 |
| F4-02 | Analog Out Channel 1 Gain | 1.00 | 5-77 |
| F4-03 | Analog Out Channel 2 Select | 3 | 5-77 |
| F4-04 | Analog Out Channel 2 Gain | 0.50 | 5-77 |
| F5-01 | Digital Out Channel 1 Select | 0 | 5-78 |
| F5-02 | Digital Out Channel 2 Select | 1 | 5-78 |
| F6-01 | DO-08 Select | 0 | 5-79 |
| F7-01 | PO-36F Select | 1 | 5-80 |
| F9-01 | Option External Fault (EFO) Selection | 0 | 5-81 |
| F9-02 | Option External Fault (EFO) Detection | 0 | 5-81 |
| F9-03 | Option External Fault (EFO) Action | 1 | 5-81 |
| F9-04 | Trace Sample Time | 0 | 5-81 |
| F9-05 | Torque Reference Limit Selection | 0 | 5-81 |
| F9-06 | DP-RAM Communication (BUS) Fault Selection | 1 | 5-81 |
| H1-01 | Terminal 3 Select | 0 | 5-82 |
| H1-02 | Terminal 4 Select | 1 | 5-82 |
| H1-03 | Terminal 5 Select | 7 | 5-82 |
| H1-04 | Terminal 6 Select | 9 | 5-82 |
| H1-05 | Terminal 7 Select | 24 | 5-82 |
| H1-06 | Terminal 8 Select | E | 5-82 |
| H2-01 | Terminal 9 Select | 0 | 5-85 |
| H2-02 | Terminal 25 Select (G5OUT1) | 0 | 5-85 |
| H2-03 | Terminal 26 Select (G5OUT2) | 7F | 5-85 |
| H3-01 | Terminal 13 Signal | 0 | 5-91 |
| H3-02 | Terminal 13 Gain | 100.0 | 5-91 |
| H3-03 | Terminal 13 Bias | 0 | 5-91 |
| H3-04 | Terminal 16 Signal | 0 | 5-91 |
| H3-05 | Terminal 16 Select | 0 | 5-91 |
| H3-06 | Terminal 16 Gain | 100.0 | 5-91 |
| H3-07 | Terminal 15 Bias | 0.0 | 5-91 |
| H3-08 | Terminal 14 Signal | 2 | 5-92 |
| H3-09 | Terminal 14 Select | 1F | 5-92 |
| H3-10 | Terminal 14 Gain | 100.0 | 5-92 |

| No. | Parameter Name | Factory Default | Ref Page# |
|------------|-------------------------------|------------------------|------------------|
| H3-11 | Terminal 14 Bias | 0.0 | 5-92 |
| H3-12 | Filter Average Time | 0.00 | 5-92 |
| H4-01 | Terminal 21 Select | 2 | 5-93 |
| H4-02 | Terminal 21 Gain | 1.00 | 5-93 |
| H4-03 | Terminal 21 Bias | 0.0 | 5-93 |
| H4-04 | Terminal 23 Select | 3 | 5-93 |
| H4-05 | Terminal 23 Gain | 1.00 | 5-93 |
| H4-06 | Terminal 23 Bias | 0.0 | 5-93 |
| H4-07 | Analog Out Level Select | 0 | 5-93 |
| H5-01 | Serial Comm Address | 1F | 5-94 |
| H5-02 | Serial Baud Rate | 3 | 5-94 |
| H5-03 | Serial Communication Parity | 0 | 5-94 |
| H5-04 | Action @ Serial Fault Select | 1 | 5-94 |
| H5-05 | Serial Fault Enable/Disable | 1 | 5-94 |
| L1-01 | Motor Overload Fault Select | 1 | 5-95 |
| L1-02 | Motor Overload Time Constant | 1.0 | 5-95 |
| L3-04 | Stall Prevention Decel Select | 0 | 5-96 |
| L4-01 | Speed Agree Level | 0.0 | 5-98 |
| L4-02 | Speed Agree Width | 2.0 | 5-98 |
| L4-03 | Speed Agree Level +/- | 0.0 | 5-98 |
| L4-04 | Speed Agree Width +/- | 2.0 | 5-99 |
| L4-05 | Reference Loss Select | 0 | 5-99 |
| L6-01 | Torque Detection 1 Select | 0 | 5-100 |
| L6-02 | Torque Detection 1 Level | 150 | 5-101 |
| L6-03 | Torque Detection 1 Time | 0.1 | 5-101 |
| L6-04 | Torque Detection 2 Select | 0 | 5-102 |
| L6-05 | Torque Detection 2 Level | 150 | 5-102 |
| L6-06 | Torque Detection 2 Time | 0.1 | 5-102 |
| L8-02 | Over Heat Pre-Alarm Level | 95 | 5-103 |
| L8-03 | Over Heat Pre-Alarm Select | 3 | 5-103 |
| L8-10 | Ground Fault Enable/Disable | 1 | 5-103 |
| L8-14 | UV3 Enable/Disable | 0 | 5-103 |
| L9-01 | Auto Reset Enable/Disable | 1 | 5-104 |
| L9-02 | Reset Attempts | 3 | 5-104 |
| L9-03 | Reset Time | 0.5 | 5-104 |
| L9-04 | Reset Fault Select 1 | 0001 | 5-105 |
| L9-05 | Reset Fault Select 2 | 0080 | 5-105 |
| O1-01 | User Monitor Select | 6 | 5-106 |
| O1-02 | Power On Monitor | 2 | 5-107 |
| O1-03 | Display Scaling | 0 | 5-107 |
| O1-04 | Display Units | 0 | 5-108 |
| O1-05 | Address Display | 0 | 5-108 |
| O2-01 | Mode/Service Key | 0 | 5-108 |
| O2-02 | Operator Stop Key | 0 | 5-108 |

| No. | Parameter Name | Factory Default | Ref Page# |
|------------|------------------------------|------------------------|------------------|
| O2-03 | User Defaults | 0 | 5-108 |
| O2-04 | KVA Selection | --- | 5-109 |
| O2-05 | Up/Down Frequency Reference | 0 | 5-110 |
| O2-06 | Operator Detection | 1 | 5-110 |
| O2-07 | Elapsed Time Set | --- | 5-110 |
| O2-08 | Elapsed Time Run | 1 | 5-110 |
| O2-10 | Run @ Power Up | 0 | 5-111 |
| O3-01 | Clear History 1 | 0 | 5-111 |
| O3-02 | Clear History 2 | 0 | 5-111 |
| U1-01 | Frequency Reference | — | 5-112 |
| U1-02 | Output Frequency | — | 5-112 |
| U1-03 | Output Current | — | 5-112 |
| U1-04 | Control Method | — | 5-112 |
| U1-05 | Motor Speed | — | 5-112 |
| U1-06 | Output Voltage | — | 5-112 |
| U1-07 | DC Bus Voltage | — | 5-112 |
| U1-08 | Output kWatts | — | 5-112 |
| U1-09 | Torque Reference | — | 5-112 |
| U1-10 | Input Terminal Status | — | 5-112 |
| U1-11 | Output Terminal Status | — | 5-112 |
| U1-12 | Inverter Control Status 1 | — | 5-112 |
| U1-13 | Elapsed Time | — | 5-112 |
| U1-14 | Flash ROM Software ID Number | — | 5-112 |
| U1-15 | Terminal 13 Level | — | 5-112 |
| U1-16 | Terminal 14 Level | — | 5-112 |
| U1-17 | Terminal 16 Level | — | 5-112 |
| U1-18 | Motor Secondary Current | — | 5-112 |
| U1-19 | Motor Excitation Current | — | 5-112 |
| U1-20 | SFS Output | — | 5-112 |
| U1-21 | ASR Input | — | 5-112 |
| U1-22 | ASR Output | — | 5-112 |
| U1-23 | Speed Deviation | — | 5-112 |
| U1-24 | PID Feedback | — | 5-112 |
| U1-25 | G5IN4 Monitor | — | 5-112 |
| U1-26 | Voltage Reference (Vq) | — | 5-112 |
| U1-27 | Voltage Reference (Vd) | — | 5-112 |
| U1-28 | CPU ID | — | 5-112 |
| U1-29 | Load Weight | — | 5-113 |
| U1-32 | ACR (q) Output | — | 5-113 |
| U1-33 | ACR (d) Output | — | 5-113 |
| U1-34 | OPE Detected | — | 5-113 |
| U1-35 | Friction Torque | — | 5-113 |
| U1-54 | U3-09 Rollovers | — | 5-113 |

| No. | Parameter Name | Factory Default | Ref Page# |
|------------|------------------------|------------------------|------------------|
| U1-55 | Software Rev | — | 5-113 |
| U2-01 | Current Fault | — | 5-113 |
| U2-02 | Last Fault | — | 5-113 |
| U2-03 | Frequency Reference | — | 5-113 |
| U2-04 | Output Frequency | — | 5-113 |
| U2-05 | Output Current | — | 5-113 |
| U2-06 | Motor Speed | — | 5-113 |
| U2-07 | Output Voltage | — | 5-113 |
| U2-08 | DC Bus Voltage | — | 5-113 |
| U2-09 | Output kWatts | — | 5-113 |
| U2-10 | Torque Reference | — | 5-113 |
| U2-11 | Input Terminal Status | — | 5-113 |
| U2-12 | Output Terminal Status | — | 5-113 |
| U2-13 | Inverter Status | — | 5-113 |
| U2-14 | Elapsed Time | — | 5-113 |
| U3-01 | Last Fault | — | 5-113 |
| U3-02 | Fault Message 2 | — | 5-113 |
| U3-03 | Fault Message 3 | — | 5-113 |
| U3-04 | Fault Message 4 | — | 5-113 |
| U3-05 | Elapsed Time 1 | — | 5-113 |
| U3-06 | Elapsed Time 2 | — | 5-113 |
| U3-07 | Elapsed Time 3 | — | 5-113 |
| U3-08 | Elapsed Time 4 | — | 5-114 |
| U3-09 | AC Operations | — | 5-114 |
| U3-10 | OL/LC Count | — | 5-114 |

* For drive model #s 2006-2080, 4003-4041 and 5003-5032 the Initial Value is 1.5. For drive model #s 2130-2300, 4052-4605 and 5041-5200 the Initial Value is 2.5.

This page intentionally left blank.

A p p e n d i x **B**

**Differences in
Software Versions**

This page intentionally left blank.

Important Product Upgrade Information

Changes in Software from 14906 to 14908/14909

| Parameter | Description | Change |
|---------------------|-------------------------------|--|
| A1-04 | Speed Reference | Default setting change from 5 step to 3 step at the request of many of our customers. |
| B5-01 | Accel Time | Default settings modified to improve operational performance during acceleration and deceleration and extend drive life by reducing peak currents |
| B5-02 | Decel Time | |
| D9-01 | S-Curve Acceleration at Start | |
| D9-02 | S-Curve Acceleration at End | |
| D9-03 | S-Curve Deceleration at Start | |
| B6-02 | Phase Loss In Level | Relocated from “factory level programming only” to Advance programming mode to allow customers greater flexibility in programming and troubleshooting the drive. |
| B6-04 | Phase Loss Out Level | |
| D1-05 | DC Injection P Gain | |
| D1-06 | DC Injection Int. Gain | |
| D1-07 | DC Injection Limit | |
| L8-10 | Ground Fault Detection | |
| L8-14 | UV3 Detection Selection | |
| C3-07 | Upper action | Parameter C3-07 (Action at UL2/LL2)=0 (decel to stop) by default. When parameter A1-03=2 (NLB Hoist) and C3-07 (Action at UL2/LL2)=0 (decel to stop), the drive will now used NLB (No Load Brake) stopping when a “lower limit stop” or “upper limit stop” is input. This input could come from the G5IN4 option card or a programmable multi-function input terminals 3~8 on the G5IF. The NLB stopping method means the drive will decelerate to a stop, load float for a period of time, continue to load float until the allotted brake close delay times has expired, and check if the electric brake is capable of holding the load (when EB6 is enabled at C8-12) before it stops outputting voltage. |
| L8-01 through C8-17 | | IMPORTANT: BE6 detection is now disabled as a default. Reference pages 5-32 through 5-41 for a detailed explanation. |
| L8-16 | Initial Brake Release Torque | New parameter, available when A1-03=2 (No Load Brake Hoist). |
| C8-17 | BE6 Up Speed | New parameter, available when A1-03=2 (No Load Brake Hoist) and C8-12 is enabled. |
| L9-01 | Reset Select | Changed at customer request to allow auto-reset of specific faults (UV1 and CE-communication errors). |
| L9-02 | Reset Attempts | |
| L9-03 | Reset Time | |
| L9-04 | Reset Fault Select 1 | |
| L9-05 | Reset Fault Select 2 | |

Changes in Software from 14908/14909 to 14911

| Parameter | Description | Change |
|---|--|---|
| B1-06 | Reference 6 | Added for Multi-Step Speeds 6, 7, and 8, see table on page 5-4. Expands multi-step inputs. |
| B1-07 | Reference 7 | |
| B1-08 | Reference 8 | |
| Parameters changed by X-Press Programming | Parameters changed by X-Press Programming | This enabled more parameters to be automatically changed based on Motion and Speed Reference. See Parameters Changed by X-Press Programming on pages 4-11 through 4-13. |
| H1-01 to H1-06 | Digital Multifunction Input (MFI) Data selection 3F and 40 | Deleted function for Digital MFI Input Data selection 3F and 40 (KEB Ride thru N.O. and KEB Ridethru N.C.). In 14908 and 14909 the selection text reads "Do Not Use". |
| H1-01 to H1-06 | Data 40 "BE6 Up Speed" | Created new Digital MFI for data 40. Data 40 now reads "BE6 Up Speed". This input limits the speed in the raise direction to the frequency reference programmed in parameter C8-17. This was implemented mainly for dual hoist applications. |
| H1-01 to H1-06 | Data 37 and 38 (External Base Block N.O. and N.C.) | Do not base block to stop if in BE5 or BE6 condition. This action is taken anytime BE5 or BE6 has been detected and successful brake proving or brake answer back has not been accomplished. The drive will instead use the NLB Stopping Sequence. |
| | BE5/BE6 | If BE5 or BE6 is detected, the output is now annunciated continuously until the BE6 routine is completed successfully or the power is removed. This was implemented mainly for dual hoist applications. |
| A1-04 | Speed Reference | Added sub menu 7 to A1-04. Data 7 text reads "Not Used". This was created to avoid OPE3 faults when using the G5IN4 for controlling speed references. If A1-04=7, Digital MFI terminals 3~8 are programmed for data F "Not Used". See Parameters Changed by X-Press Programming on pages 4-11 through 4-13. |
| G5IN4 Table | | Rearranged G5IN4 table with more practical data. See page 5-42. |
| <u>Parameters now changed based on KVA.</u> | | |
| C4-02 | Zero Servo Gain | Reference page 5-27 |
| C8-01 | Torque Compensation Time | Reference page 5-34 |
| C8-02 | IFB OK Time | Reference page 5-34 |

| Parameter | Description | Change |
|------------------|--------------------|--|
| B3-03 | Stopping Method | Fixed B3-03 sub menu from displaying stopping methods that will not work with the current Control Method and Motion. See Table 1 for details. |
| H2-03 | H2-03, Digit 1A | Corrected spelling of Digital Multifunction Output (MFO) Data 1A "Forward Dir". Previously spelled "Foreword Dir" |
| D10-01 | Carrier Frequency | Changed default to optimize performance. |
| C2-01/C2-02 | Micro Speed | Improved accuracy of Mirco Speed calculation at Gain settings below 0.1. |
| C8-18 to C8-21 | PG Monitor Setup | Added memory within the drive has allowed us to enhance safety capabilities by providing a level of redundancy in monitoring the encoder. Default setting is enabled. For applications using a 600 PPR encoder or less consult factory for recommended parameter settings. Reference pages 5-34 to 5-37. |
| F1-16 to F1-18 | Pulse Input Setup | Added to software as a feature to provide a level of redundancy in monitoring the encoder. Example of appropriate usage would be the nuclear industry. Reference page 5-75. |

Table 1

| Control Method (A1-02) | Motion (A1-03) | Stopping Method (B3-03) |
|-------------------------------|-----------------------|--------------------------------|
| 3-Flux Vector | 0- Traverse | 0-Ramp to Stop |
| | | 1-Coast to Stop |
| | | 4-Ramp w/Timer |
| | 2-NLB Hoist | 0-Ramp to Stop |
| | | 1-Coast to Stop |
| | | 6-No Load Brake |

Appropriate Software Upgrades for 14911 would utilize Impulse Link 3.053, Data Pulse 2.001 and Data Logger v1.23.

Changes in Software from 14911 to 14912

| Parameter | Description | Change |
|--|--|--|
| O2-08 | Running Time | In order to more accurately track the amount of “Actual Run Time” on the drive, the default value for parameter O2-08 has been changed from “Power On Time” to “Running Time”. This will allow for more useful information to be stored since the Power On Time would quickly exceed the maximum value allowed for the Monitor U1-13 where the “Elapsed Time” is actually displayed to the user. |
| F1-15 | PGO Detect Time | Increased detection time to 0.3 seconds. |
| O2-10 | Run @ Power Up | Advanced Access Level Parameter O2-10 was created in order to allow the ability to “Disable” the prevention of the drive accepting a run command at power up. This is part of a safety feature that was introduced in version 14911 software. Its purpose is to give an “EF” External Fault alarm which is displayed on the keypad and prevent the drive from running until the run command is cycled. If the application calls for the drive to begin running immediately at power up, set O2-10 to enabled. |
| C2-01 and C2-02 | Micro Speed 1 and 2 with Infinitely Variable | This modification was done to improve accuracy of Micro Speed gain 1 and 2 when a 0.5 multiplier or less is used. This will correct an error that was due to rounding. Two separate calculations will be done: one if the gain is equal to or less than 1.00, and the second if the gain is 1.01-2.55. NOTE: The upper limit of 2.55 is required for radio controls to over-speed as they are limited to a maximum frequency of 60 Hz. Additionally, revisions were made in the calculations to correct an overflow that would occur if the maximum frequency is set above approx. 90 Hz and the micro speed gain is set to 1.00 or a little under 1.00. Also, while using micro speed gain 1 or 2 in conjunction with 3-step infinitely variable, when the Accel Hold MFI was turned on AND Micro speed gain was on (C2-01=0.2 in this case), the freq (frequency reference) would jump to 12 Hz. This problem has been corrected and the freq now remains constant. |
| U1-55 | Software Rev | U1-55 parameter was added to distinguish the difference between software revisions without changing the flash Id (U1-14). The decimal point after the Flash id represents the same decimal # that is present in U1-55 i.e. U1-14=14911, U1-55=1.2. Software is referred to as 14911.2 Note: This additional parameter is used only when very minor modifications have been made to the software. The Flash Id will remain unchanged in order to be backward compatible with other support software tools. |
| F9 Group | Dual Port RAM | Added Dual Port RAM Support |
| C8-10 | Load Float | Load Float is now possible for traverse motions by setting a time in parameter C8-10. |
| U1-54 | U3-09 Rollovers | Keeps track of how many times U3-09 has rolled over. When U3-09=10,000, it is reset to zero and U1-54 is incremental. |
| X-Press | Terminal Setup | Modified terminal setup in the express programming table to prevent the improper programming of terminals. |
| B5-03–B5-04 | Accel/Decel Time 2 | Extends the range of accel/decel time 2 (B5-03 and B5-04) up to 6,000 seconds. |
| C8-12 C8-13 | BE6 detection | Enabled BE6 detection Due to overwhelming customer requests, “BE6 Detection” will be activated as part of the standard factory IMPULSE•VG+ Series 2 drive setup. It is therefore imperative that the user provide an annunciation device for a BE6 alarm or disable the function. (See page 5-35 for instructions on disabling BE6 detection). NOTE: Each IMPULSE•VG+ Series 2 drive will have a tag affixed to a wiring terminal reminding the customer about the above condition. |
| C13-01 | Inch Run Time | Added Inch Function |
| C13-02 | Run Delay Time | Added Inch Function |
| IMPULSE•Link, DataPulse and DataLogger | New Software | Requires IMPULSE•Link version 3.058, DataPulse version 2.004 and DataLogger V1.25. |