

IMPULSE•G+

Series 2

Adjustable Frequency/Vector Crane Controls

Instruction Manual



ELECTROMOTIVE SYSTEMS
by **M** MagneTek

G+S214911-00A Software #14911 June 2000

Part Number: 005-1058

© Copyright 2000 Electromotive Systems

For use with software versions 14908-14911

©2000 ELECTROMOTIVE SYSTEMS

All rights reserved. This notice applies to all copyrighted materials included with this product, including, but not limited to, this manual and software embodied within the product. This manual is intended for the sole use of the persons to whom it was provided, and any unauthorized distribution of the manual or dispersal of its contents is strictly forbidden. This manual may not be reproduced in whole or in part by any means whatsoever without the expressed written permission of ELECTROMOTIVE SYSTEMS by MagneTek.

***DANGER, WARNING, CAUTION, and NOTE* Statements**

DANGER, WARNING, CAUTION, and Note statements are used throughout this manual to emphasize important and critical information. You must read these statements to help ensure safety and to prevent product damage. The statements are defined below.



DANGER

DANGER indicates an imminently hazardous situation which, if not avoided, will result in death or serious injury. This signal word is to be limited to the most extreme situations.



WARNING

WARNING indicates a potentially hazardous situation which, if not avoided, could result in death or serious injury.



CAUTION

CAUTION indicates a potentially hazardous situation which, if not avoided, could result in minor or moderate injury. It may also be used to alert against unsafe practices.

NOTE: A *NOTE* statement is used to notify people of installation, operation, programming, or maintenance information that is important, but not hazard-related.

Disclaimer of Warranty

Electromotive Systems hereafter referred to as Company, assumes no responsibility for improper programming of a drive by untrained personnel. A drive should only be programmed by a trained technician who has read and understand the contents of this manual. Improper programming of a drive can lead to unexpected, undesirable, or unsafe operation or performance of the drive. This may result in damage to equipment or personal injury. Company shall not be liable for economic loss, property damage, or other consequential damages or physical injury sustained by the purchaser or by any third party as a result of such programming. Company neither assumes nor authorizes any other person to assume for Company any other liability in connection with the sale or use of this product.



WARNING

Improper programming of a drive can lead to unexpected, undesirable, or unsafe operation or performance of the drive.

Contents

Disclaimer of Warranty	ii
Welcome!	vii
Identifying Your Drive	viii

Chapter 1: Introduction

Introduction	1-4
Assessing the System Requirements	1-4
Assessing the Drive Environment	1-4
IMPULSE•G+ Series 2 General Specifications	1-5
CDBM & CDBR Units	1-7
Minimum Resistor Ohmic Values	1-7
Installation/Wiring of CDBR/CDBM Braking Unit	1-12
AC Reactor Specifications	1-14
Interface Cards Specifications	1-16

Chapter 2: Installation

IMPULSE•G+ Series 2 System Components And External Devices	2-4
Long Time Storage	2-6
Installing the Drive	2-7
IMPULSE•G+ Series 2 Dimensions/Heat Loss—Open Chassis	2-9

Chapter 3: Wiring

IMPULSE•G+ Series 2 Wiring Practices	3-3
Suggested Circuit Protection Specifications and Wire Size	3-5
Wiring the Power Circuit	3-7
Wiring the Control Circuit	3-12
Control Input	3-12
Additional Input Terminals	3-12
Control Output	3-12
Wiring the Control Circuit—Procedures	3-13
Control Circuit Terminals	3-16

Chapter 4: Programming Basic Features

Overview	4-3
Checks Before Powering	4-3
Precautions	4-3
Using the Keypad.....	4-4
Keypad LED and Button Functions	4-5
Parameters.....	4-6
Parameter Modes	4-8
Initialization Set-up.....	4-9
Auto-Tuning	4-15

Chapter 5: Programming Advanced Features

Application	5-3
Preset Reference	5-3
Reference Limits.....	5-5
Sequence/Reference Source	5-6
Trim Control Level.....	5-13
Acceleration/Deceleration	5-14
Accel/Decel Time Switching Frequency	5-15
Torque Limit Accel/Decel	5-16
Phase Loss Detection	5-17
Jump Frequencies	5-18
Special Functions	5-19
Quick Stop™/Reverse Plug Simulation™	5-20
Micro-Positioning Control Gain.....	5-22
End of Travel Limits.....	5-23
Load Check™.....	5-25
Swift Lift™.....	5-27
Torque Limit (Open Loop Vector).....	5-29
Brake Answer Back	5-29
G5IN4 Digital Multi-Function Inputs.....	5-30
Delay Timers.....	5-34

Inching Control	5-35
Tuning	5-36
DC Injection	5-36
Automatic Slip Compensation	5-38
Example	5-39
Torque Compensation	5-40
Droop Control	5-41
Dwell Function	5-42
S-Curve Acceleration/Deceleration	5-43
Carrier Frequency	5-45
Hunt Prevention	5-46
Factory Tuning	5-47
Motor Parameters	5-48
Voltage/Frequency Pattern	5-48
Motor Set-up	5-51
Motor 2 Method	5-52
Motor 2 Voltage/Frequency Pattern	5-52
Motor 2 Set-up	5-53
Option Parameters	5-54
Analog Input 14 Set-up	5-54
Digital Input Option Set-up	5-55
Analog Output Option Set-up	5-56
Digital Output 2 Set-up	5-57
Digital Output 8 Set-up	5-58
PO-36F Set-up	5-59
Terminal Parameters	5-60
Digital Inputs	5-60
Digital Outputs	5-63
Digital Outputs—Fault Annunciate (H2-01~03=40)	5-65
External Fault Response Selection	5-67
Analog Inputs	5-68
Analog Outputs	5-70

Serial Communication Set-up	5-71
Protection Parameters	5-72
Motor Overload	5-72
Stall Prevention	5-73
Reference Detection	5-79
Torque Detection	5-81
Hardware Protection	5-84
Automatic Reset	5-85
Example:	5-87
Operator Parameters	5-88
Monitor Selection	5-88
Keypad Key Selection	5-90
Clear History	5-93
Monitor Parameters	5-94

Chapter 6: Troubleshooting IMPULSE•G+ Series 2

Troubleshooting the Drive	6-3
Maintenance and Inspection	6-3
Motor Faults and Corrective Actions	6-4
Drive Faults and Indicators	6-4
Fault Display and Corrective Actions at Auto-tuning	6-10
(Open Loop Vector)	6-10
Troubleshooting CDBR Faults	6-11
Power Section Check	6-12
Power Off Checks	6-12
Braking Circuit	6-14

Appendix A: Servicing IMPULSE•G+ Series 2

Service	A-3
Service Policy For Small Drives, DBUs, and Other Electrical Components	A-3
Service Policy for Large Drives	A-4
Electromotive Systems Limited Warranty	A-6
IMPULSE•G+ Series 2 Parameter Listing	A-7

Appendix B: Differences in Software Versions

Important Product Upgrade Information	B-3
Changes in Software from 14906 to 14908/14909	B-3
Changes in Software from 14908/14909 to 14911	B-4

This page intentionally left blank.

Welcome!

IMPULSE•G+ Series 2 drive is versatile — it can function both as an open-loop vector control or a standard scalar control (adjustable voltage/frequency control).

Whether it is used as an open-loop vector or a scalar control, IMPULSE•G+ Series 2 is ideal for a variety of traverse and hoist functions with mechanical load brakes. Built-In Auto-Tuning enables the drive in the open-loop vector configuration to adjust its output performance to the motor — *without an encoder*. The scalar control method is often used with *multi-motor systems*. IMPULSE•G+ Series 2 offers a 100:1 speed ratio as a open-loop vector control and 40:1 as a scalar control (compared to a 3:1 range for two-speed motors and a 10:1 ratio for wound-rotor motors).

Improving overhead material handling performance, the IMPULSE•G+ Series 2 includes the following special features:

- Distinct speed control (up to nine speeds) as well as infinitely variable speed control are provided. Pendant push-button stations, infrared or radio controls, or joysticks can be used.
- An English, plain-language liquid crystal display (2 lines, 16 characters per line) makes programming, troubleshooting, and operating the drive easy.
- Built-in Serial Communication (9600-baud modbus) provides reliable digital linkage among the various crane system peripherals, including PulseStar™ Remote Crane Controls.
- Micro-Positioning Control™ is used to place loads with a high degree of precision, eliminating the need to jog or reverse-plug motors.
- A compact circuit design gives the drive a small footprint.
- Safe Operating Windows™ prevents programming the drive with unsafe parameters.
- Swift-Lift™ capabilities enhance productivity by quickly positioning hoist hooks under no-load or light-load conditions.
- A snap-in, removable keypad helps limit programming access and reduces the possibility of programming errors.
- Load Check™ prevents from overstressing equipment by attempting to lift a load beyond the capacity of the crane or hoist.
- Phase Loss Detection causes the drive to fault and commands the electric brake to set if an input or output phase loss occurs.
- Quick Stop™ ensures a rapid deceleration to stop once a drive RUN command is removed, reducing the possibility of a crane collision.
- Reverse Plug Simulation™ allows for rapid change of travel direction (motor's phase sequence), before the electric brake can be set.
- Flash ROM stores the drive system's last four fault occurrences in the drive's memory — even after power-down — for diagnostic purposes.
- A 120V Control Voltage Interface Card gives direct access to a 120V user input device (e.g., pendant) without adding electro-mechanical components.
- Elapsed Time Counter (with fault history) indicates actual operation time, total power-up time, and elapsed time between fault occurrences.

Identifying Your Drive

If you ever have to contact Electromotive Systems about your drive, first determine the model and serial numbers of your drive by looking at the nameplate shown below.

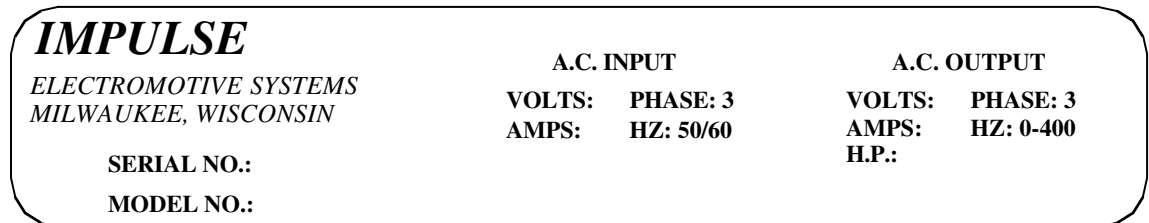

This nameplate is located on the side of the drive nearest to the keypad.

c h a p t e r **1**

Introduction

This page intentionally left blank.



WARNING

- Do not touch any circuitry components while the main AC power is on. In addition, you must wait until the red “CHARGE” LED is out before performing any service on that unit. (As you look at the face of the circuitry, the “CHARGE” LED is located in the lower right corner of the board.) It may take as long as 10 minutes for the charge on the main DC bus capacitors to drop to a safe level.
- Do not check signals during operation.
- Do not connect the main output terminals (T1, T2, T3) to the incoming, three-phase AC source.
- Do not connect the control board terminals, which are the 27 two-tiered terminals, directly to the 120VAC user input device.
- Before executing Built-In Auto-Tuning, ensure that the motor is disconnected from the drive train and the electric brake is released. If the electric brake cannot be released, you must ensure that the brake is disengaged for the entire tuning process.

The instructions in the next three chapters apply to most IMPULSE•G+ Series 2 crane, hoist, and monorail applications. However, you need to carefully evaluate your specific situation and ensure that you follow NEC codes and your local wiring practices.

These chapters tell you how to install IMPULSE•G+ Series 2 and, to some extent, the components that it interconnects. It explains how to: assess the drive’s environment, mount the drive, and wire the drive circuits. It’s important to develop a “plan of attack” for both the mounting and wiring since each task has an effect on the other one. To assist you, “IMPULSE•G+ Series 2 Wiring Practices” is included.

NOTE: If your IMPULSE•G+ Series 2 is part of an Electromotive Systems, pre-engineered TCONTROLS® motor control panel, disregard this chapter and turn to Chapter 4.

Introduction

The instructions in this chapter apply to most IMPULSE•G+ Series 2 crane, hoist, and monorail applications. However, carefully evaluate your specific situation and ensure that NEC codes and local wiring practices are followed.

Assessing the System Requirements

You must also know how you're going to use the drive before you start installation and wiring. You need to know your requirements for the following components:

- Speed control method(s)
- Braking method(s)
- Power source voltage, number of phases, and kVA rating.
- Power source location
- Wire size
- Grounding location and method

Assessing the Drive Environment

When choosing a location for IMPULSE•G+ Series 2, perform the following steps:

1. Ensure that a 230V (-15% to +10%) three-phase power source is available for a 230V-rated drive, 380V, 400V, 415V, 440V, or 460V (-15% to +10%) three-phase power source is available for a 460V-rated drive and that a 500V, 575V, 600V (-15% to +10%) power source is available for a 575V drive.
2. Ensure that the drive-to-motor wiring distance is less than 250 ft. unless appropriate reactors and/or filters are used.
3. Line reactors should be used :
 - When connecting a drive (230V/460V/575V, Model 2033/4034/5032 and smaller) to a large-capacity power supply transformer (500kVA or greater or more than 10 times the inverter kVA rating).
 - When switching a phase-advancing capacitor, excessive peak current can flow through the input power supply circuit. To prevent damage to the rectifier section in such cases, install a DC reactor between drive Terminals 1 and 2, or an AC reactor on the input side. Installing reactors also improves the power factor on the power supply side.
4. Ensure that the drive circuit wiring is protected or isolated from:
 - Rain or moisture
 - Corrosive gases or liquids
 - Direct sunlight
 - Severe mechanical vibration
 - Enclosure temperature must remain within the range of +14° F to +113° F (-10° C to +45° C). A heater or air conditioner must be used if the above requirements are not met.
5. Ensure that the drive is housed in an appropriate NEMA-rated enclosure.
6. For severe-duty applications (for example—long lifts) or with 75-Hp-or-greater motors, ensure that the drive control system is adequately cooled, even though the ambient temperature limit is not exceeded. For further assistance, contact Electromotive Systems.

IMPULSE•G+ Series 2 General Specifications

230V Class

Specification	Specification Values and Information for Each 230V-Class Model (####-AFG+)												
	2006	2008	2011	2017	2025	2033	2054	2068	2080	2130	2160	2224	2300
Rated current (A)	6	8	11	17.5	25	33	54	68	80	130	160	224	300
Capacity (kVA)	2.3	3.0	4.2	6.7	9.5	13	19	24	30	50	61	85	110

460V Class

Specification	Specification Values and Information for Each 460V-Class Model (####-AFG+)																			
	4001	4003	4005	4008	4011	4014	4021	4028	4034	4041	4052	4065	4080	4096	4128	4165	4224	4302	4450	4605
Rated current (A)	1.9	3.6	5.1	8.5	11.7	14.8	21	28.6	34	41	52	65	80	96	128	165	224	302	450	605
Capacity (kVA)	1.4	2.6	3.7	6.1	8.4	11	16	21	26	31	40	50	61	73	98	130	170	230	340	460

575V Class

Specification	Specification Values and Information for Each 575V-Class Model (####-AFG+)																
	5003	5004	5006	5009	5012	5017	5022	5027	5032	5041	5052	5062	5077	5099	5130	5172	5200
Rated current (A)	3.5	4.41	6.3	9.8	12.5	17	22	27	32	41	52	62	77	99	130	172	200
Capacity (kVA)	2	3	5	7.5	10	15	20	25	30	40	50	60	75	100	125	150	200

230V, 460V and 575V Classes

Specification	Specification Value and Information for All Models
Certification	UL, CUL, CSA
Rated input power supply volts & freq	3-phase 200-220 or 380-460 or 500-600; 50 or 60 Hz
Allowable input voltage fluctuation	+10% or -15% of nominal
Allowable input frequency fluctuation	±5% of nominal
Control method	Fully digital, sine-wave, pulse-width-modulated; sensorless vector
Maximum output voltage (VAC)	Max output voltage 3-phase, 200/208/220/230V;380/400/415/440/460/500/575/600V (proportional to input voltage.)
Rated frequency (Hz)	Up to twice motor nameplate rpm (Swift-Lift) 120 Hz Max
Output speed control range	100:1
Output frequency accuracy	.01%—with digital reference command, -10° to 40° C; .1%—with analog reference command; 10 bits/10V; 25° C, ±10° C
Frequency reference resolution	Digital: .01 Hz; analog: .03 Hz (at 60 Hz)
Output frequency resolution	.01 Hz
Overload capacity	120% of rated load for 1 min
Remote frequency reference sources	0–10VDC (20kΩ); 4–20mA (250Ω); ±10VDC (optional); serial (optional)
Accel/decel times	0.1 to 25.5 sec—2 sets; 4 parameters are independently adjustable

Specification	Specification Value and Information for All Models
Braking torque	Approximately 20% if motor and inverter are sized 1:1; 150% or more with dynamic braking (optional)
Motor overload protection	Electronic thermal overload relay; field-programmable
Overcurrent protection level (OC1)	200% of rated current
Circuit protection	Ground fault and blown-fuse protection
Overvoltage protection level	400/800/1000VDC
Undervoltage protection level	190/380/546VDC
Heatsink over temperature	Thermostat trips at 105° C
Torque limit selection	Separate functions for FORWARD, REVERSE, REGEN; all selectable from 0–300%
Stall prevention	Separate functions for accel, decel, at-speed, and constant Hp region
Other protection features	Output phase loss, input phase loss, failed-oscillator detection, and mechanical overload detection
DC bus voltage indication	Charge LED is on until DC bus voltage drops below 50VDC
Location	Indoors; requires protection from moisture, corrosive gases and liquids
Ambient operating temperature	14° to 113°F (-10 to 45°C) for open chassis
Storage temperature	-4° to 140° F (-20° to 60° C)
Humidity	90% relative; noncondensing
Vibration	1 G less than 20 Hz; 0.2 G for 20–50 Hz
Elevation	3300 ft. (1000m) or less

CDBM & CDBR Units

The CDBM and CDBR are designed to pass regenerative energy from an inverter’s DC bus to a resistor bank. The CDBM/CDBR operate when the voltage on the DC bus reaches a specific level which turns on an internal transistor. This transistor stays on until the DC bus voltage drops to an appropriate level. The difference between the turn on and the turn off voltage is the hysteresis voltage.

The CDBM/CDBR, and its associated dynamic braking resistor, are used to help the inverter decelerate AC motors (dynamic braking) and to provide a path for motor regenerative energy under over hauling conditions, such as on a hoist.

Minimum Resistor Ohmic Values

The following chart should be used to determine minimum ohmic values for dynamic braking resistors for different supply voltages.

Supply Voltage	Turn On Voltage	Minimum Ohmic Value for Braking Resistor							
		CDBM-2015	CDBM-2022	CDBM-4030	CDBM-4045	CDBM-4090	CDBM-4220	CDBM-5037	
		CDBR-2015B	CDBR-2022B	CDBR-2110	CDBR-4030B	CDBR-4045B	CDBR-4090	CDBR-4220	CDBR-5037
200V	330V	8.3	5.5	1.3	—	—	—	—	—
208V	345V	8.6	5.8	1.4	—	—	—	—	—
220V	365V	9.1	6.1	1.5	—	—	—	—	—
230V	380V	9.5	6.3	1.5	—	—	—	—	—
380V	630V	—	—	—	15.8	10.5	6.3	2.5	—
400V	660V	—	—	—	16.5	11.0	6.6	2.6	—
415V	690V	—	—	—	17.3	11.5	6.9	2.8	—
440V	730V	—	—	—	18.3	12.2	7.3	2.9	—
460V	760V	—	—	—	19.0	12.7	7.6	3.0	—
500	825V	—	—	—	—	—	—	—	20.6
575	950V	—	—	—	—	—	—	—	23.8

CDBM & CDBR Braking Unit Specification

Braking Unit Model		200V to 300V			308V to 460V				500V to 575V
		2015	2022	—	4030	4045	4090	4220	5037
CDBM		2015	2022	—	4030	4045	4090	4220	5037
CDBR		2015B	2022B	2110	4030B	4045B	4090	4220	5037
Applicable Motor Output HP (kW)		20 (15)	30 (22)	150 (110)	40 (30)	60 (45)	120 (90)	300 (220)	57 (37)
Output Charac- teristics	Max. Discharge Current (A (peak value))*	40	60	250	40	60	100	250	40
	Rated Discharge Current (A)	15	20	80	15	18	30	80	15
	Braking Start Voltage	330/345/365/380V ±3V			630/660/690/730/760V ±6V				825V/950V ± 8V
	Max. Hysteresis Error	Approx. 8V			Approx. 16V				Approx. 20V
Power Supply	VDC	243 (1.35 x 200 x 0.9) to 400V peak			460 (1.35 x 380 x 0.9) to 800V peak				607 (1.35 x 500 x 0.9) to 1000V
	VAC†	— Single phase 200 to 220V 50Hz 200 to 230V 60Hz			—				Single phase 380 to 460V 50Hz/ 60Hz
Protective Functions	Fin Overheat	Thermostat							
	Power Charge Indication	Charge lamp stays ON until bus voltage drops below 50V.							
Environ- mental Conditions	Location	Indoor (protected from corrosive gases and dust)							
	Ambient Temperature	+14° to 104°F (-10° to +40°C) (not frozen)							
	Storage Temperature	-4° to +140°F (-20° to +60°C)							
	Humidity	90%RH (non-condensing)							
	Vibration	1G at less than 20Hz, up to 0.2G at 20 to 50 Hz							
Protective Configuration		Wall-mounted enclosed type							
Heat Loss (W)		32	38	129	54	59	94	135	70

* Loading time rate can be used below 10% ED (max. 10 min.)

† AC power supply for cooling fan is used only for models CDBR-2110 and CDBR-4220.

CDBM Braking Unit Dimensions

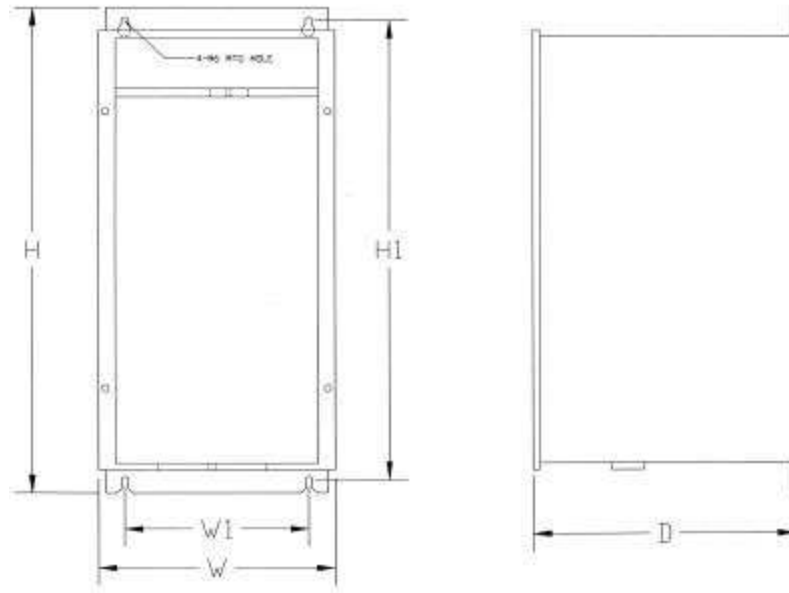

Figure 1-1: CDBM Dimensions

Model Number	Dimensions in inches (mm)					
	Overall			Mounting		
	W	H	D	W1	H1	d
CDBM-2015	5.53 (140.5)	11.0 (279.5)	5.91 (150)	3.94 (100)	10.24 (260)	0.24 (6)
CDBM-2022						
CDBM-4030						
CDBM-4045						
CDBM-4090	8.50 (216)	14.50 (368)	5.94 (151)	7.09 (180)	13.98 (355)	
CDBM-4220	10.63 (270)	14.50 (368)	7.25 (184)	8.27 (210)	13.98 (355)	
CDBM-5037	5.53 (140.5)	11.0 (279.5)	5.91 (150)	3.94 (100)	10.24 (260)	

CDBR-B Braking Unit Dimensions

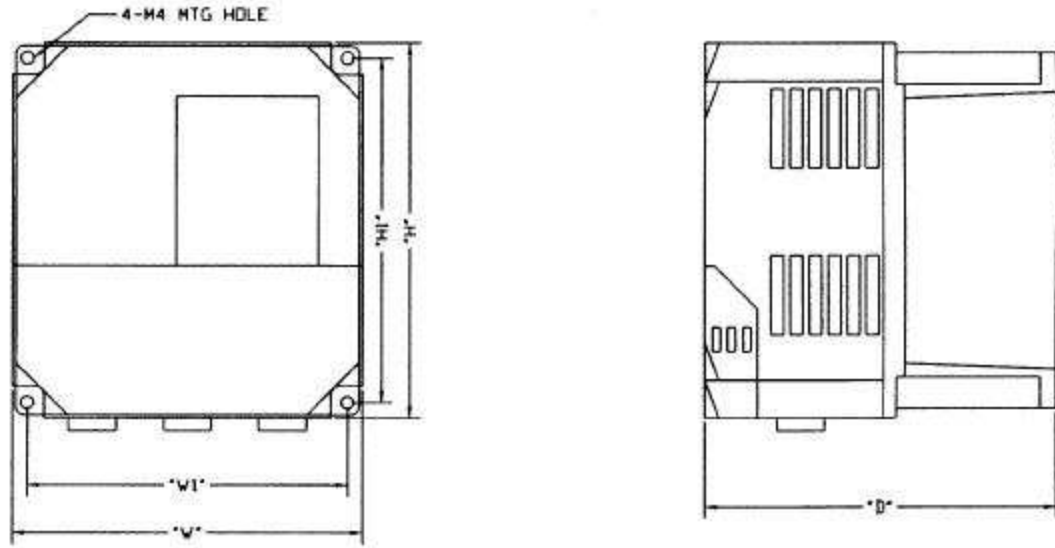

Figure 1-2: CDBR-B Dimensions

Model Number	Dimensions in inches (mm)						Wt. in lbs. (kg)
	Overall			Mounting			
	W	H	D	W1	H1	d	
CDBR-2015B							
CDBR-2022B							
CDBR-4030B	5.51 (140)	5.91 (150)	5.45 (138.5)	5.04 (128)	5.43 (138)	.16 (4)	7.79 (3.54)
CDBR-4045B							

CDBR Braking Unit Dimensions

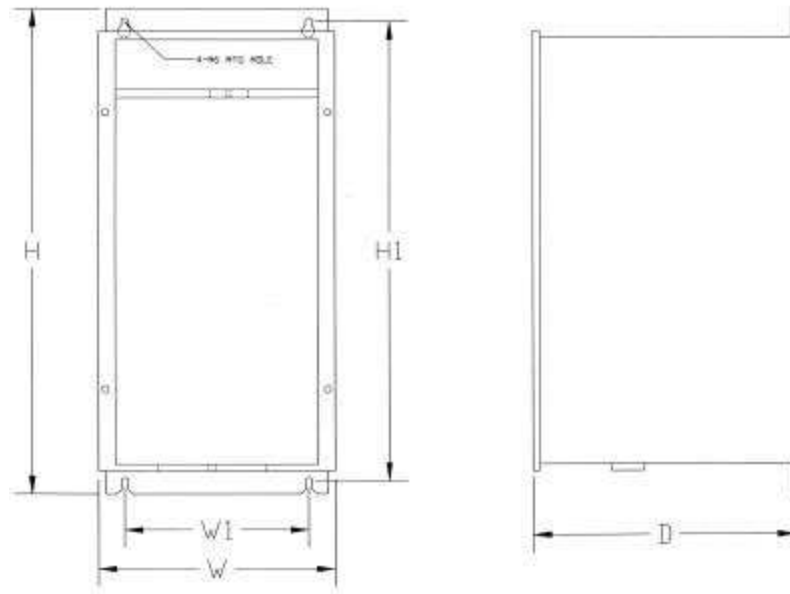

Figure 1-3: CDBR Dimensions

Model Number	Dimensions in inches (mm)					
	Overall			Mounting		
	W	H	D	W1	H1	d
CDBR-2110	7.09 (180)	14.57 (370)	7.87 (200)	5.51 (140)	13.78 (350)	
CDBR-4090	8.66 (220)	14.76 (375)	7.87 (200)	7.09 (180)	13.98 (355)	0.24 (6)
CDBR-4220	9.84 (250)	14.76 (375)	7.87 (200)	8.27 (210)	13.98 (355)	
CDBR-5037	5.51 (140)	11.02 (280)	6.29 (160)	3.94 (100)	10.23 (260)	

Installation/Wiring of CDBR/CDBM Braking Unit



WARNING

120 VAC is not needed for the control circuit to operate. If 120 VAC is applied to terminals 1, 2, 5 or 6, DAMAGE TO THE UNIT WILL RESULT.

- NOTE:*
- *Some Braking units have only a symbol labeling the terminal.*
 - *Most resistors do not have P_0 (r_0) and B (S_0) designators.*
 - *Polarity does not matter on the resistor.*

1. Wire N (S) on the CDBR/CDBM to N (S) on the drive.
2. Wire P (r) on the CDBR/CDBM to P(r) on the drive.
3. Wire the P_0 (r_0) on the CDBR/CDBM to the dynamic braking resistor.
4. Wire B (S_0) on the CDBR/CDBM to the dynamic braking resistor.
5. CDBR model #4220 has an internal fan. It requires terminals r and s to be wired to one phase of the 460V line voltage in order to power the fan.
6. Terminals 3 and 4 are the Cooling Fin Overheat Contact.
Thermoswitch contact rating: 250VAC, 1A max
30VDC, 1A max
7. Terminals 1, 2, 5 and 6 are used for **MASTER/SLAVE** Operation. Use twisted-pair wires of 14 AWG or smaller for connection between 5, 6, and 1, 2 on the braking units. Parallel connection is possible up to a maximum of 10 units. Refer to Figure 1-4 (page 1-13) for parallel connection of braking units.
8. Set the Voltage Selection Jumper to match the voltage of the incoming power source.
9. Set the Master/Slave Jumper to Master for single unit operation.
10. For further information, refer to CDBR/CDBM manual.

AC Reactor Specifications

Reactors, both as input (line) and output (load) devices, protect adjustable frequency drives, motors, and other load devices against excessive voltage and current.

The following guidelines may help determine input and output reactor requirements:

- Install an input reactor if the power source is greater than 500 kVA.
- Install an output reactor if the distance between the drive and the motor exceeds 250 feet.
- Install an output reactor if a device (power limit switch) is used to disconnect the motor from the drive.
- Install one output reactor per drive for a multiple-drive arrangement requiring reactor protection.
- For a multiple drive arrangement, an input reactor for each drive is recommended for optimal protection. However, if the drives are within two drive sizes of each other, a single input reactor can be used. The reactor must be rated at an amperage equal to or greater than the sum of the amperage for all the drives.

230V Class

Model Number	230V Part Number	Maximum Amps of Reactor
2006-AFG+	REA230-2	8
2008-AFG+	REA230-2	8
2011-AFG+	REA230-3	12
2017-AFG+	REA230-5	18
2025-AFG-	REA230-7.5	25
2033-AFG+	REA230-10	35
2054-AFG+	REA230-20	55
2068-AFG+	REA230-25	80
2080-AFG+	REA230-30	80
2130-AFG+	REA230-50	130
2160-AFG+	REA230-60	160
2224-AFG+	REA230-100	250
2300-AFG+	REA230-125	320

460V Class

Model Number	460V Part Number	Maximum Amps of Reactor
4001-AFG+	REA460-1	2
4003-AFG+	REA460-2	4
4005-AFG+	REA460-5	8
4008-AFG+	REA460-5	8
4011-AFG+	REA460-7.5	12
4014-AFG+	REA460-10	18
4021-AFG+	REA460-15	25
4028-AFG+	REA460-20	35
4034-AFG+	REA460-25	35
4041-AFG+	REA460-30	45
4052-AFG+	REA460-40	55
4065-AFG+	REA460-50	80
4080-AFG+	REA460-60	80
4096-AFG+	REA460-75	100
4128-AFG+	REA460-100	130
4165-AFG+	REA460-150	200
4224-AFG+	REA460-200	250
4302-AFG+	REA460-250	320
4450-AFG+	REA460-400	500
4605-AFG+	REA460-500	600

575V Class

Model Number	575V Part Number	Maximum Amps of Reactor
5003-AFG+	REA575-2 & 3	4
5004-AFG+	REA575-2 & 3	4
5006-AFG+	REA575-5	8
5009-AFG+	REA575-10	12
5012-AFG+	REA575-10	12
5017-AFG+	REA575-15	18
5022-AFG+	REA575-20 & 25	25
5032-AFG+	REA575-30	35
5041-AFG+	REA575-40	45
5052-AFG+	REA575-50	55
5062-AFG+	REA575-60 & 75	80
5077-AFG+	REA575-60 & 75	80
5099-AFG+	REA575-100	100
5130-AFG+	REA575-150	160
5172-AFG+	REA575-200	200
5200-AFG+	REA575-200	200

Interface Cards Specifications

IMPULSE•G+ Series 2 is designed to interface directly with a 120VAC user input and output devices via G5IF, G5IN4, and G5OUT interface cards. This eliminates the need for additional interface relay or isolation circuitry.

G5IF has eight optically isolated terminals which can be used to connect with the user input device. Terminals 1 and 2 are always used for the directional run commands (Forward and Reverse or Up and Down). The rest of six terminals are multi-function terminals, and are used for speed control and other characteristics. With multi-function terminals you can assign various functions and performance characteristics without having to rewire the control circuitry.

G5OUT has two 240VAC, 1.5 Amp solid state relays for output indication devices. It includes two programmable multi-function output terminals.

G5IN4 card has four additional input terminals, which can have a total of 14 sets of input selections. The individual terminals can be enabled/disabled within a set. For program information refer to the advanced programming section in Chapter 5.

Model Number	Rated Input Voltage (AC)	Rated Maximum Current
G5IF*	120V	1.5 Amp
G5OUT	240V	1.5 Amp
G5IN4*	120V	1.5 Amp

*Other input voltages are available. Consult Electromotive Systems.

c h a p t e r **2**

Installation

This page intentionally left blank.



WARNING

- When preparing to mount the IMPULSE•G+ Series 2 drive, lift it by its base. Never lift it by the front cover.
- Mount the drive on nonflammable material.
- The IMPULSE•G+ Series 2 drive generates heat. For the most effective cooling possible, mount it vertically. For more details, refer to the “IMPULSE•G+ Series 2 Dimensions/ Heat Loss—Open Chassis” on pages 2-9 through 2-11.
- When mounting units in an enclosure, install a fan or other cooling device to keep the enclosure air temperature below 113°F (45°C).

Failure to observe these Warnings may result in equipment damage.

This chapter explains the following:

1. Choosing a location
2. IMPULSE•G+ Series 2 components and external devices
3. Drive environment
4. Drive installation

In addition, this section will cover information on the components that interconnect with IMPULSE•G+ Series 2.

Choosing a Location

Be sure that the drive is mounted in a location protected against the following conditions:

- Extreme cold and heat. Use only within the ambient temperature range:
Open Chassis: +14 to 113°F (-10 to 45°C)
- Direct sunlight (not for use outdoors)
- Rain, moisture
- High humidity
- Oil sprays, splashes
- Salt spray
- Dust or metallic particles in the air
- Corrosive gases (e.g. sulfurized gas or liquids)
- Radioactive substances
- Combustibles (e.g. thinner, solvents, etc.)
- Physical shock, vibration
- Magnetic noise (e.g. welding machines, power devices, etc.)

IMPULSE•G+ Series 2 System Components And External Devices

Standard IMPULSE•G+ Series 2 Drive Components

- G5IF 120V Control Voltage Interface Card

Optional Drive Components

- G5OUT Control Output Card
- G5IN4 Control Input Card
- D0-08 Control Output Board
- D0-02 Control Output Relay Board
- AI-14B Analog Input Card

As-Required Drive Components

- AC reactor—line or load
- DC bus reactor
- External dynamic braking resistor(s) (See “Installation/Wiring of CDBR/CDBM Braking Unit” in Chapter 1, page 1-12.)
- External dynamic braking unit

Required External Devices

- Motor
- User input device (pendant, joystick, PC, PLC, radio, or infrared control)
- External circuit protection devices (fuses or circuit breakers) (See “Suggested Circuit Protection Specifications and Wire Size in Chapter 3, page 3-5.)
- R-C surge suppressors on contactor coils

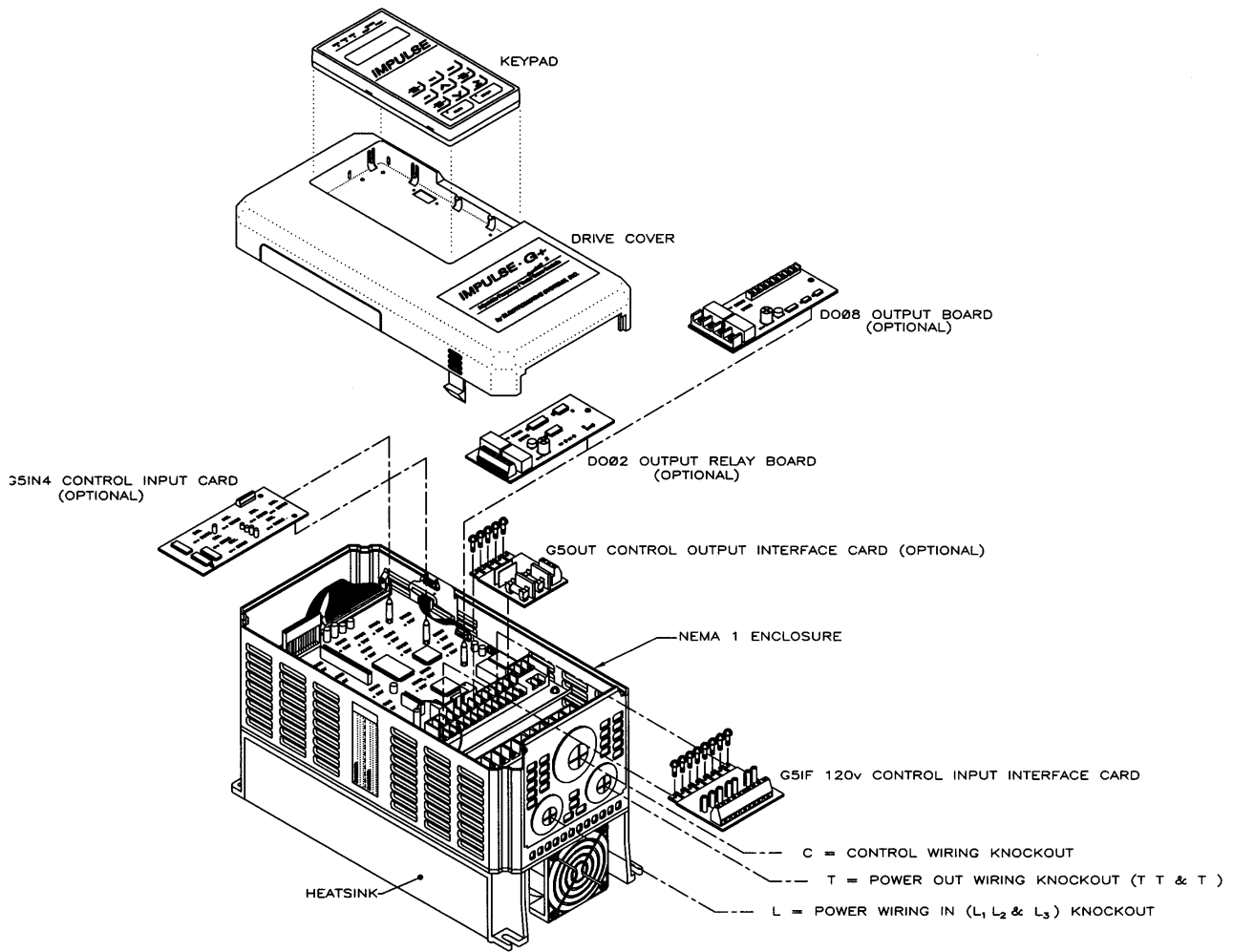

Figure 2-1: IMPULSE•G+ Series 2 Components Diagram Installing the Drive

Long Time Storage

When an inverter stored for six months or more without operation, reforming of the main circuit electrolytic capacitor is required.

NOTE: If the procedure is not feasible, the drive may be powered up every six months using rated line voltage.

Execute the reforming as follows:

1. Connect a single or three phase variable AC supply to the inverter input terminals L1-L3.
2. Increase the voltage linearly to the rated input voltage for a period of three minutes.
3. Apply rated input voltage for 30-60 minutes or longer.

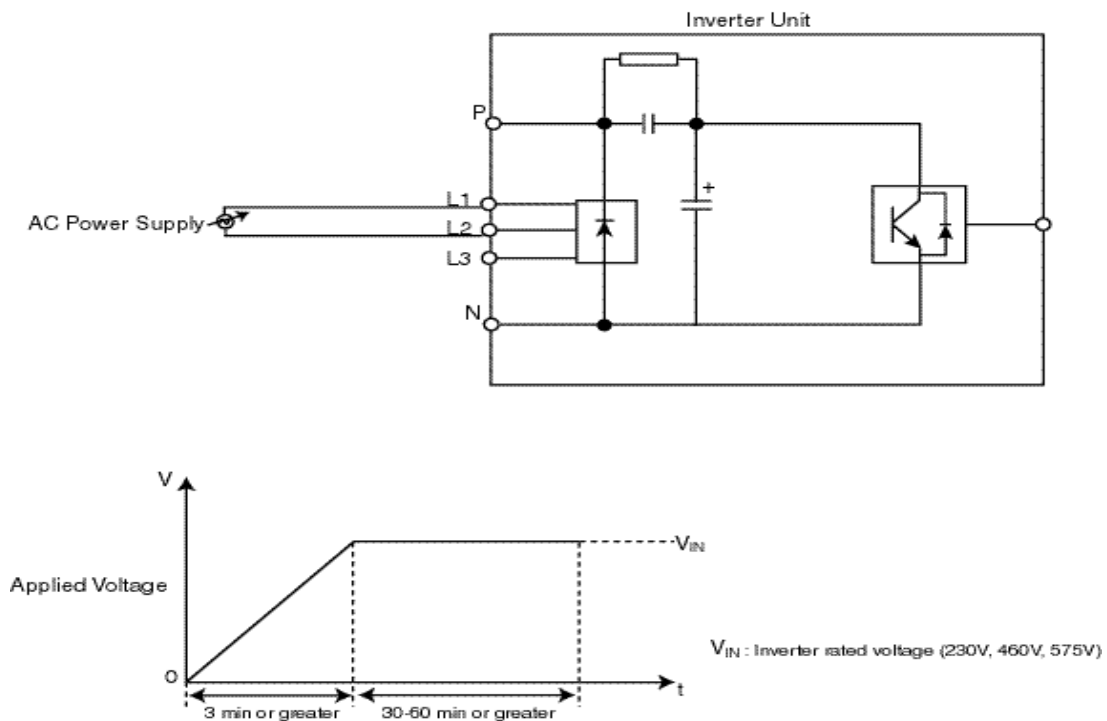

Figure 2-2: Long Time Storage

Installing the Drive

To install IMPULSE•G+ Series 2:

1. Ensure the drive will be used in a proper environment. Refer to page 1-4.
2. Review Figure 2-1: “IMPULSE•G+ Series 2 Components Diagram” on page 2-5 and Figure 3-3: “IMPULSE•G+ Series 2 Terminal Diagram” on page 8.
3. Determine the sizes and connection locations for the drive components and external devices that need to be wired. Locate the ground. For exact dimensions, see Figures 2-6: “IMPULSE•G+ Series 2 Dimensions—Open Chassis,” pages 2-9 through 2-11.
4. Determine the position of the subpanel.
5. Ensure that the drive is positioned vertically so that the heat can dissipate properly.
6. Ensure that the air can flow freely around the heat sink as shown below in Figure 2-3.

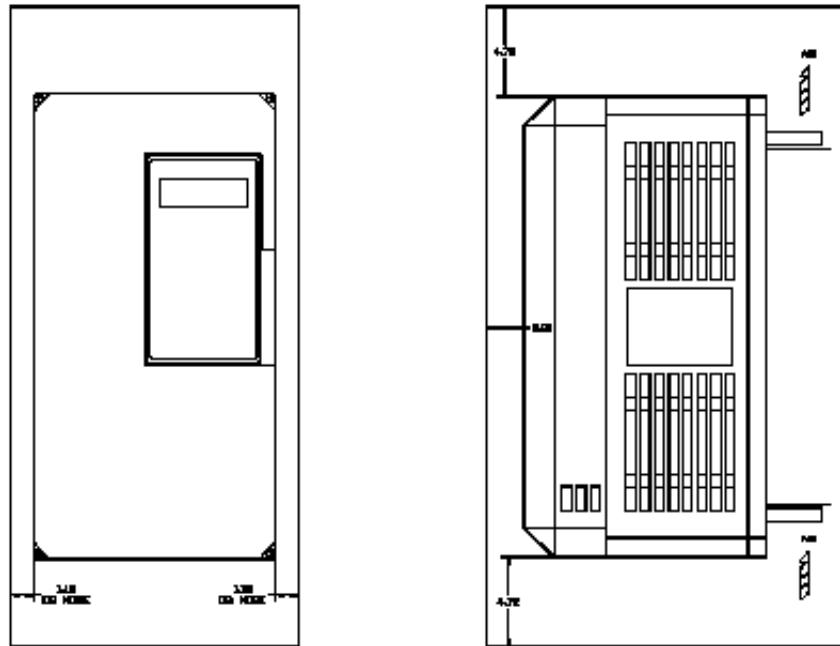

Figure 2-3

NOTES:

- *The required clearances at the top, bottom, and both sides of the inverter are the same for both open chassis and NEMA 1 enclosures.*
- *Allowable intake air temperature: 14°F to 104°F (-10°C to +40°C)*
- *If necessary, a heater or air conditioner must be used to maintain the temperature range listed above.*

7. Lay out the wire runs. Size the wire according to NEC Table 610-14(a). At a minimum, use #16 AWG for control wiring and #12 AWG for power wiring. When performing this step:
 - Ensure that the drive control circuit and power circuit wires are perpendicular to each other at any point they cross.
 - Keep power and control festoon wiring in separate cables.
 - Separate control drive circuit and power circuit wiring on the terminal block strip.
8. Obtain the appropriate hardware for mounting.
9. Mount the subpanel or surface to which you are mounting the drive. (Contact Electromotive Systems if you need advice on mounting, especially for larger drives.)
10. Fasten the drive and components to the subpanel.
11. Remove the keypad from the front cover by pushing the depression area and lifting the keypad as shown below in Figure 2-4

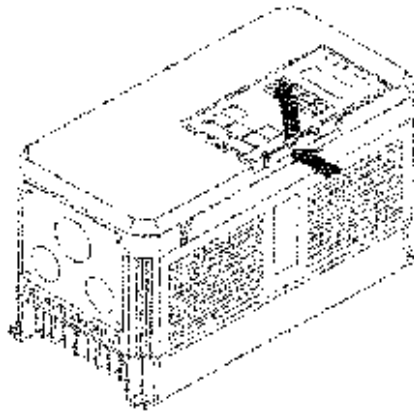

Figure 2-4

12. Remove the drive cover. For Models 2003-AFG+ through 2033-AFG+ and 4001-AFG+ through 4014-AFG+ and 5003-AFG+ through 5022-AFG+. See below, Figure 2-5. On larger size drives, the cover is attached with screws.

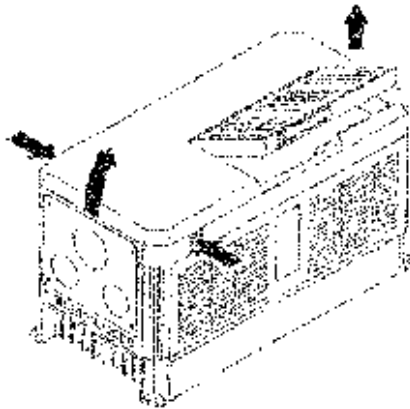

Figure 2-5

13. Remove the G5OUT Card (if used).
14. Remove the G5IF Card.
15. Follow the wiring practices outlined in Chapter 3.

IMPULSE•G+ Series 2 Dimensions/Heat Loss—Open Chassis

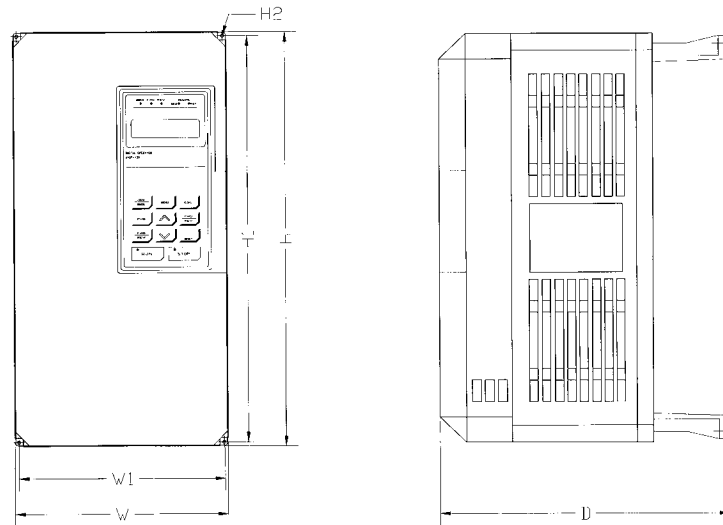

Figure 2-6: Open Chassis

NOTE: Some models are shipped with metal enclosures that can be removed and discarded.

230 Volt

Model	Overall Dimensions in inches and (mm)			Mounting Dimensions in inches and (mm)			Heat Loss (W)	
	W	H	D	W1	H1	H2	Wt Lbs/(kg)	Total
2006-AFG+	5.51 (140)	11.02 (280)	6.30 (160)	4.95 (126)	10.47 (266)	0.28 (7)	6.5 (3)	90
2008-AFG+	5.51 (140)	11.02 (280)	6.30 (160)	4.95 (126)	10.47 (266)	0.28 (7)	6.5 (3)	120
2011-AFG+	5.51 (140)	11.02 (280)	7.09 (180)	4.95 (126)	10.47 (266)	0.28 (7)	10 (4.5)	140
2017-AFG+	5.51 (140)	11.02 (280)	7.09 (180)	4.95 (126)	10.47 (266)	0.28 (7)	10 (4.5)	215
2025-AFG+	7.87 (200)	11.81 (300)	8.07 (205)	7.32 (186)	11.22 (285)	0.31 (8)	12 (5.5)	300
2033-AFG+	7.87 (200)	11.81 (300)	8.07 (205)	7.32 (186)	11.22 (285)	0.31 (8)	13 (6)	345
2054-AFG+	9.84 (250)	14.96 (380)	8.86 (225)	9.29 (236)	14.37 (365)	0.30 (7.5)	24 (10.8)	585
2068-AFG+	9.84 (250)	14.96 (380)	8.86 (225)	9.29 (236)	14.37 (365)	0.30 (7.5)	24 (10.8)	725
2080-AFG+	12.80 (325)	17.72 (450)	11.22 (285)	10.83 (275)	17.13 (435)	0.30 (7.5)	62 (28)	885
2130-AFG+	16.73 (425)	26.57 (675)	13.78 (350)	12.60 (320)	25.59 (650)	0.49 (12.5)	134 (61)	1370
2160-AFG+	16.73 (425)	26.57 (675)	13.78 (350)	12.60 (320)	25.59 (650)	0.49 (12.5)	137 (62)	1730
2224-AFG+	18.70 (475)	31.50 (800)	13.78 (350)	14.57 (370)	30.51 (775)	0.49 (12.5)	176 (80)	2630
2300-AFG+	22.64 (575)	36.42 (925)	15.75 (400)	17.52 (445)	35.24 (895)	0.59 (15)	298 (135)	3210

460 Volt

Model	Overall Dimensions—in. & (mm)			Mounting Dimensions—in. & (mm)			Wt Lbs/(kg)	Heat Loss
	W	H	D	W1	H1	H2		Total (W)
4001-AFG+	5.51 (140)	11.02 (280)	6.30 (160)	4.95 (126)	10.47 (266)	0.28 (7)	6.5 (3)	60
4003-AFG+	5.51 (140)	11.02 (280)	6.30 (160)	4.95 (126)	10.47 (266)	0.28 (7)	6.5 (3)	85
4005-AFG+	5.51 (140)	11.02 (280)	7.09 (180)	4.95 (126)	10.47 (266)	0.28 (7)	8.8 (4)	110
4008-AFG+	5.51 (140)	11.02 (280)	7.09 (180)	4.95 (126)	10.47 (266)	0.28 (7)	10 (4.5)	145
4011-AFG+	5.51 (140)	11.02 (280)	7.09 (180)	4.95 (126)	10.47 (266)	0.28 (7)	10 (4.5)	200
4014-AFG+	7.87 (200)	11.81 (300)	8.07 (205)	7.32 (186)	11.22 (285)	0.31 (8)	13 (6)	220
4021-AFG+	7.87 (200)	11.81 (300)	8.07 (205)	7.32 (186)	11.22 (285)	0.31 (8)	13 (6)	360
4028-AFG+	9.84 (250)	14.96 (380)	8.86 (225)	9.29 (236)	14.37 (365)	0.30 (7.5)	24 (11)	455
4034-AFG+	9.84 (250)	14.96 (380)	8.86 (225)	9.29 (236)	14.37 (365)	0.30 (7.5)	24 (11)	570
4041-AFG+	12.80 (325)	17.72 (450)	11.22 (285)	10.83 (275)	17.13 (435)	0.30 (7.5)	60 (27)	660
4052-AFG+	12.80 (325)	17.72 (450)	11.22 (285)	10.83 (275)	17.13 (435)	0.30 (7.5)	60 (27)	880
4065-AFG+	12.80 (325)	24.61 (625)	11.22 (285)	10.83 (275)	24.02 (610)	0.30 (7.5)	97 (44)	1020
4080-AFG+	12.80 (325)	24.61 (625)	11.22 (285)	10.83 (275)	24.02 (610)	0.30 (7.5)	97 (44)	1245
4096-AFG+	12.80 (325)	24.61 (625)	11.22 (285)	10.83 (275)	24.02 (610)	0.30 (7.5)	97 (44)	1385
4128-AFG+	17.91 (455)	32.28 (820)	13.78 (350)	13.78 (350)	31.30 (795)	0.49 (12.5)	174 (79)	1820
4165-AFG+	17.91 (455)	32.28 (820)	13.78 (350)	13.78 (350)	31.30 (795)	0.49 (12.5)	176 (80)	2320
4224-AFG+	22.64 (575)	36.42 (925)	14.76 (375)	17.52 (445)	35.24 (895)	0.59 (15)	298 (135)	3030
4302-AFG+	22.64 (575)	36.42 (925)	15.75 (400)	17.52 (445)	35.24 (895)	0.59 (15)	320 (145)	4190
4450-AFG+	37.40 (950)	57.09 (1450)	17.13 (435)	29.53 (750)	55.12 (1400)	0.98 (25)	794 (360)	6850
4605-AFG+	37.80 (960)	62.99 (1600)	17.91 (455)	29.53 (750)	61.02 (25)	0.98 (25)	926 (420)	9730

575 Volt

Model	Overall Dimensions—in. & (mm)			Mounting Dimensions—in. & (mm)			Wt Lbs/(kg)	Heat Loss (W)
	W	H	D	W1	H1	H2		Total
5003-AFG+	5.51 (140)	11.02 (280)	7.09 (180)	4.96 (126)	10.47 (266)	0.28 (7)	8.8 (4)	90
5004-AFG+	5.51 (140)	11.02 (280)	7.09 (180)	4.96 (126)	10.47 (266)	0.28 (7)	8.8 (4)	105
5006-AFG+	7.87 (200)	11.81 (300)	8.07 (205)	7.32 (186)	11.22 (285)	0.31 (8)	13 (6)	140
5009-AFG+	7.87 (200)	11.81 (300)	8.07 (205)	7.32 (186)	11.22 (285)	0.31 (8)	14 (6.5)	205
5012-AFG+	7.87 (200)	11.81 (300)	8.07 (205)	7.32 (186)	11.22 (285)	0.31 (8)	14 (6.5)	220
5017-AFG+	9.84 (250)	14.96 (380)	8.86 (225)	9.29 (236)	14.37 (365)	0.29 (7.5)	28 (13)	330
5022-AFG+	9.84 (250)	14.96 (380)	8.86 (225)	9.29 (236)	14.37 (365)	0.29 (7.5)	28 (13)	460
5027-AFG+	15.75 (400)	29.53 (750)	11.22 (285)	11.81 (300)	28.74 (730)	0.39 (10)	97 (44)	540
5032-AFG+	15.75 (400)	29.53 (750)	11.22 (285)	11.81 (300)	28.74 (730)	0.39 (10)	97 (44)	730
5041-AFG+	22.64 (575)	33.46 (850)	11.81 (300)	18.71 (475)	32.48 (825)	0.49 (12.5)	156 (72)	820
5052-AFG+	22.64 (575)	33.46 (850)	11.81 (300)	18.71 (475)	32.48 (825)	0.49 (12.5)	156 (72)	1220
5062-AFG+	22.64 (575)	33.46 (850)	11.81 (300)	18.71 (475)	32.48 (825)	0.49 (12.5)	156 (72)	1650
5077-AFG+	22.64 (575)	41.34 (1050)	12.80 (325)	18.70 (475)	40.35 (1025)	0.49 (12.5)	195 (90)	1750
5099-AFG+	22.64 (575)	41.97 (1066)	12.80 (325)	18.70 (475)	40.35 (1025)	0.49 (12.5)	195 (90)	2250
5130-AFG+	22.80 (579)	57.68 (1465)	12.99 (330)	18.70 (475)	48.23 (1225)	0.49 (12.5)	271 (125)	2350
5172-AFG+	22.80 (579)	77.43 (1966.5)	13.98 (355)	18.70 (475)	61.81 (1570)	0.59 (15)	331 (153)	3200
5200-AFG+	22.80 (579)	77.43 (1966.5)	13.98 (355)	18.70 (475)	61.81 (1570)	0.59 (15)	342 (158)	4700

This page intentionally left blank.

c h a p t e r **3**

Wiring

This page intentionally left blank.

IMPULSE•G+ Series 2 Wiring Practices



WARNING

Before you wire the drive, review the following practices to ensure that your system is wired properly.

- **DO NOT** connect the output terminals (T1, T2, and T3) to the incoming, three-phase AC source. This will result in non-warranty damage to the unit!
- Except for Terminals 9, 10, 18, 19, and 20, **DO NOT** connect the control board terminals directly to 120VAC. This will result in non-warranty damage to the unit!
- Ensure that the drive-to-motor wiring distance is less than 150 ft. unless appropriate reactors and/or filters are used.
- If a device that can interrupt power is installed between the drive and the motor, install a load reactor on the output side of the drive. Note: A make before break contact must be used on such devices.
- On external user input devices, use hard contact inputs rather than solid-state inputs.
- If the user input device is a solid state device or a PLC TRIAC output, use a 5-K Ω , 10-W resistor in parallel with the signal and X2.
- If the power source is 500 kVA or greater, or more than 10 times the inverter kVA rating, ensure that there is at least 3 percent impedance between the power source and the drive input. To accomplish this, you can install a DC reactor between inverter terminals \oplus 1 and \oplus 2, or use an A-C line reactor on the input of the drive. If you don't provide enough impedance, excessive peak currents could damage the input power supply circuit.
- Comply with "Suggested Circuit Protection Specifications and Wire Size."
- Use time delay fuses, which are sized at 150% of drive's continuous-rated current, for drive input protection.
- Use appropriate R-C or MOV type surge absorbers across the coil of all contactors and relays in the system. Failure to do so could result in noise-related, nuisance fault incidents.
- Ensure that the drive is solidly grounded to the enclosure subpanel and that all ground leads are as short as possible. (Refer to Grounding on page 3-9).
- Use external dynamic braking resistors for all applications.
- Do not ground the drive with any large-current machines.
- Before using any welding or high-current equipment near the drive, disconnect all wires from the drive.
- Do not use output contactors between the drive and the motor.
- Do not let the wiring leads come in contact with the drive enclosure.
- Do not connect power factor correction capacitors to the drive input or output.
- Hard-wire the drive and motor (e.g., festoon cable). Do not use sliding collector bars.
- Before turning on the drive, check the output circuit (T1, T2 and T3) for possible short circuits and ground faults.

- Increase the wire size by one size for every 250 ft. between the drive and motor; suggested for center driven cranes, trolleys and bridges.
- When using more than one transformer for the drive's power, properly phase each transformer.
- Use shielded cable for all low-level DC speed reference signals (0 to 10VDC, 4 to 20 mA). Ground the shield only at the drive side.
- Please observe National Electrical Code (NEC) guidelines when wiring electrical devices.

Failure to observe these warnings may result in equipment damage.

Suggested Circuit Protection Specifications and Wire Size

In order to comply with most safety standards, some circuit protective devices should be used between the incoming three-phase power supply and the IMPULSE•G+ Series 2. These devices can be thermal, magnetic, or molded-case breakers (MCCB); or “slow-blow”-type fuses such as “CCMR” or “J.”



CAUTION:

The following guidelines are only suggested values. Always conform to local electrical codes and wiring practices.

Model #	Rated Current(A)		Time Delay	Inverse Time	Wiring Size (AWG/MCM)		
	Drive	InputFuse	Input Fuse Class	Molded/Case Circuit Breaker	Power Circuit Wiring	Control Wiring	Ground
230V Class							
2006 -AFG+	6	9	CC	15	12	16/14	14/10
2008 -AFG+	8	12	CC	20	12	16/14	12/10
2011 -AFG+	11	20	CC	25	12	16/14	12/10
2017 -AFG+	17.5	25	J	40	12	16/14	10
2025 -AFG+	25	35	J	60	10	16/14	10/8
2033 -AFG+	33	45	J	70	10	16/14	10/8
2054 -AFG+	54	70	J	100	6	16/14	8
2068 -AFG+	68	90	J	100	4	16/14	6
2080 -AFG+	80	100	J	175	4	16/14	6
2130 -AFG+	130	175	J	250	1/0	16/14	4
2160 -AFG+	160	200	J	300	1/0	16/14	4
2224 -AFG+	224	300	J	450	4/0	16/14	2
2300 -AFG+	300	400	J	600	2/0 x 2P	16/14	1
460V Class							
4001 -AFG+	1.9	3	CC	10	12	16/14	12/10
4003 -AFG+	3.6	6	CC	10	12	16/14	12/10
4005 -AFG+	5.1	8	CC	15	12	16/14	12/10
4008 -AFG+	8.5	15	CC	20	12	16/14	12/10
4011 -AFG+	11.7	20	CC	25	12	16/14	12/10
4014 -AFG+	14.8	25	CC	30	12	16/14	8/6
4021 -AFG+	21	30	J	50	10	16/14	8
4028 -AFG+	28.6	40	J	60	10	16/14	8
4034 -AFG+	34	45	J	80	8	16/14	8
4041 -AFG+	41	60	J	80	8	16/14	8
4052 -AFG+	52	70	J	125	6	16/14	8
4065 -AFG+	65	90	J	125	6	16/14	8
4080 -AFG+	80	100	J	150	4	16/14	6
4096 -AFG+	96	125	J	200	2	16/14	6

Model #	Rated Current(A)		Time Delay	Inverse Time	Wiring Size (AWG/MCM)		
	Drive	InputFuse	Input Fuse Class	Molded/Case Circuit Breaker	Power Circuit Wiring	Control Wiring	Ground
4128 -AFG+	128	175	J	250	1/0	16/14	4
4165 -AFG+	165	225	J	350	2/0	16/14	4
4224 -AFG+	224	300	J	450	4/0	16/14	2
4302 -AFG+	302	400	J	600	2/0 x 2P	16/14	1
4450 -AFG+	450	600	J	900	2/0 x 2P	16/14	1/0
4605 -AFG+	605	800	L	1450	250 MCM x 2P	16/14	1/0
575V Class							
5003-AFG+	3.5	5	CC	10	12	16/14	12/10
5004-AFG+	4.1	7	CC	10	12	16/14	12/10
5006-AFG+	6.3	10	CC	15	12	16/14	12/10
5009-AFG+	9.8	15	CC	20	12	16/14	12/10
5012-AFG+	12.5	20	CC	30	12	16/14	12/10
5017-AFG+	17	25	CC	40	12	16/14	8/6
5022-AFG+	22	35	J	50	10	16/14	8
5027-AFG+	27	40	J	60	10	16/14	8
5032-AFG+	32	45	J	80	10	16/14	8
5041-AFG+	41	60	J	80	8	16/14	8
5052-AFG+	52	70	J	125	6	16/14	8
5062-AFG+	62	90	J	125	4	16/14	8
5077-AFG+	77	100	J	150	4	16/14	6
5099-AFG+	99	125	J	200	2	16/14	6
5130-AFG+	130	175	J	250	1/0	16/14	4
5172-AFG+	172	225	J	350	2/0	16/14	4
5200-AFG+	200	300	J	450	4/0	16/14	2

Wiring the Power Circuit

To wire the power circuit for IMPULSE•G+ Series 2:

1. Run the three-phase power supply wires through an appropriate enclosure hole.
2. Refer to “Suggested Circuit Protection Specification and Wire Size” on page 3-5 and connect the three-phase power supply wires to a circuit protection system.
3. If a line reactor is used, connect the three-phase power supply wires from the circuit protection to the input of the reactor. Then connect the output of the reactor to Terminals L1, L2 and L3.
4. From Terminals T1, T2 and T3, connect the power output wires to the motor. If a load reactor is used, connect these output wires to the reactor input instead; then connect the reactor output to the motor.

NOTE: *If a device that can interrupt power is installed between the drive and the motor, install a reactor on the output side of the drive. This must be a make before break contact.*

5. For Models 4041-AFG+ and greater, ensure the jumper plug is inserted in the printed-circuit board (3PCB), which is below the control board. See below Figures 3-1 and 3-2.

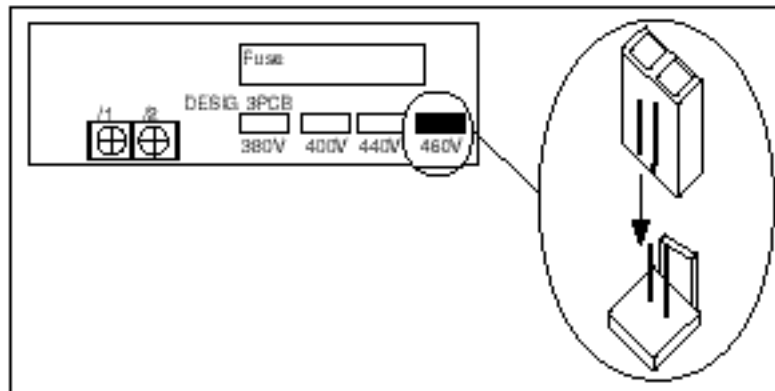

Figure 3-1: Models 4041-AFG+ to 4096-AFG+

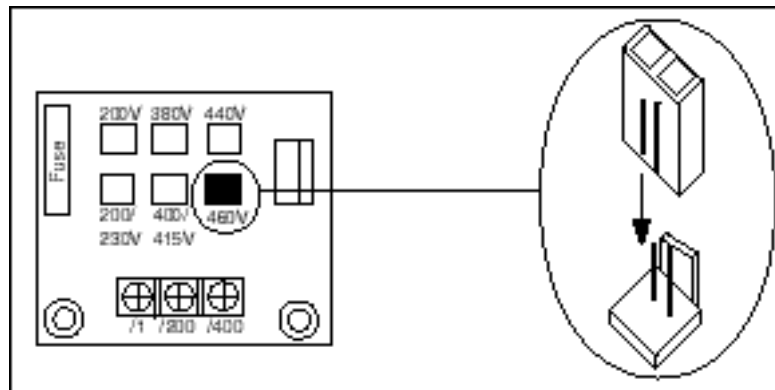

Figure 3-2: Models 4128-AFG+ to 4605-AFG+

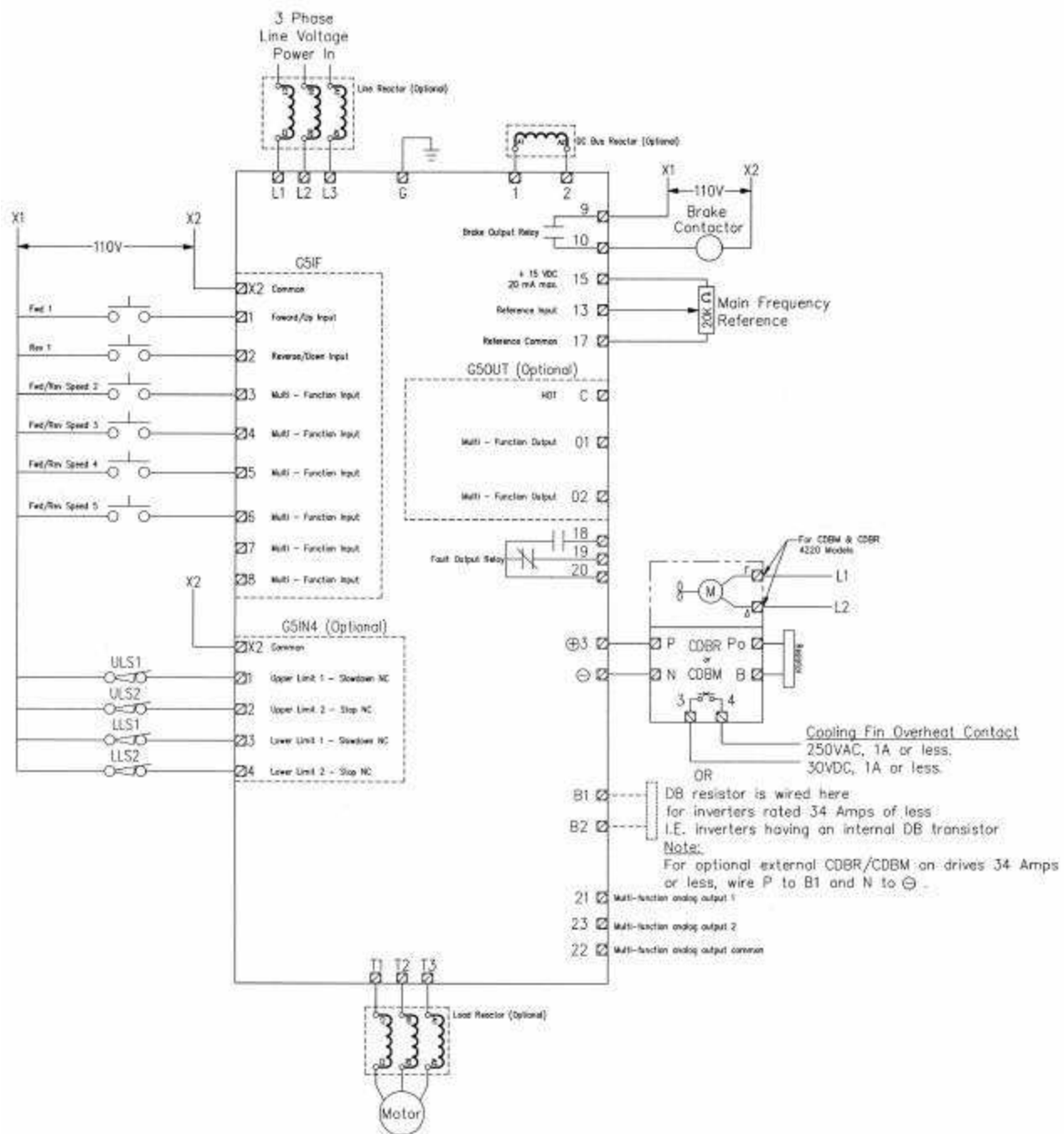
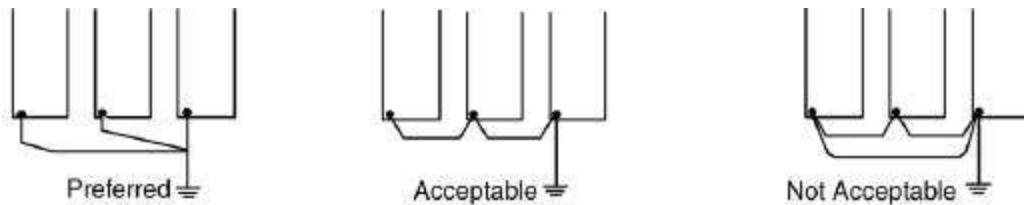

Figure 3-3: IMPULSE•G+ Series 2 Terminal Diagram

Grounding

Connect terminal G to the common panel ground. Use ground wiring as specified in “Suggested Circuit Protection and Wire Size” on page 3-5, and keep the length as short as possible.

- Ground Resistance: 230V class; 100 Ω or less, 460V or greater class; 10 Ω or less.
- Never ground the IMPULSE•G+ Series 2 drives with welding equipment, motors, or other high-current electrical equipment. Run all ground wiring in separate conduit.
- When more than one drive is used for the same system, ground each directly or daisy-chain to the ground pole. Do not loop the ground wires.



Grounding of three IMPULSE • G+ Series 2 Drives

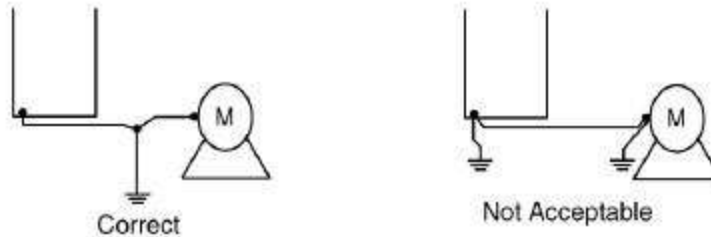

Grounding of IMPULSE • G+ Series 2 Drive and Motor

Figure 3-4: Grounding

230 V Class Terminal Functions

	<i>Model</i>	2006-AFG+ to 2033-AFG+	2054-AFG+ to 2068-AFG+	2080-AFG+	2130-AFG+ to 2300-AFG+
	<i>Rated Current</i>	6 to 33 Amps	54 to 68 Amps	80 Amps	130 to 300 Amps
Terminal	L1	Main circuit input power supply			
	L2				
	L3				
	T1	Inverter output			
	T2				
	T3				
	B1	Braking resistor	n/a		
	B2				
	S	DC reactor (⊕1-⊕2) DC Power supply (⊕1-S)	DC reactor (⊕1-⊕2) DC power supply (⊕1-⊕) Braking unit (⊕3-S)	DC power supply (⊕1-S) Braking unit (⊕3-S) (⊕1 and ⊕2 terminals not provided)	
	⊕1				
	⊕2				
	⊕3	n/a		Cooling fan power supply	
	r				
	s	Ground terminal (Ground resistance: 100 Ω or less)			

460 V Class Terminal Functions

	<i>Model</i>	4003-AFG+ to 4034-AFG+	4041-AFG+ to 4096-AFG+	4128-AFG+ to 4302-AFG+	4450-AFG+ to 4605-AFG+
	<i>Rated Current</i>	3.6 to 34 Amps	41 to 96 Amps	128 to 302 Amps	450 to 605 Amps
Terminal	L1	Main circuit input power supply			
	L2				
	L3				
	T1	Inverter output			
	T2				
	T3				
	B1	Braking resistor	n/a		
	B2				
	S	DC reactor (⊕1-⊕2) DC power supply (⊕-S)	DC power supply (⊕1-S) Braking unit (⊕3-S)	Braking unit (⊕3-S) (⊕1 and ⊕2 terminals not provided)	
	⊕1				
	⊕2				
	⊕3	n/a	n/a		
	s	Cooling fan power supply			
	r			Cooling fan power supply (Control power supply) r-s200: 200 to 230VAC input r-s400: 380 to 460VAC input	
	s200				
s400	n/a				
	Ground terminal (Ground resistance: 10Ω or less)				

575 V Class Terminal Functions

	<i>Model</i>	5003-AFG+ to 5032-AFG+	5003-AFG+ to 5017-AFG+	5041-AFG+ to 5200-AFG+
	<i>Rated Current</i>	3 to 32 Amps	3 to 17 Amps	41 to 200 Amps
Terminal	L1 (R)	Main circuit input power supply		
	L2 (S)			
	L3 (T)			
	T1 (u)	Inverter output		
	T2 (V)			
	T3 (W)			
	B1	Braking resistor		n/a
	B2			
	S	DC reactor (⊕1-⊕2) DC power supply (⊕-S) Braking Unit(⊕-S)	DC power supply (⊕1-S) Braking unit (⊕1-S) (⊕2 terminal not provided)	
	⊕1			
	⊕2			
	l 1(r)	n/a		Cooling fan power supply
	l 2(s)			
	⏚	Ground terminal (Ground resistance: 10 Ω or less)		

Wiring the Control Circuit

Control Input

IMPULSE•G+ Series 2 is designed to interface directly with a 120VAC user input device. User input devices include: pendant controls (pushbutton station), remote control transmitters (infrared and radio), master switches, programmable logic controls (PLC), and personal computers. This design feature eliminates the need for interface relays or isolation circuitry. The user interface device is connected to the G5IF 120V Control Interface Card, which includes Terminals 1, 2, 3, 4, 5, 6, 7, and 8. Four more terminals can be added with the optional G5IN4 120V Control Input Card.

NOTE: Terminal X2 is also on both control input cards, and should always be connected to X2 of the user input device.

For the G5IF, Terminals 1 and 2 are always used for the directional run commands (FORWARD, [UP] REVERSE, [DOWN]). The remaining terminals are multi-function terminals, and are used for speed control and other features. Multi-function terminals allow the user to assign entirely different functions and performance characteristics without having to rewire the drive.

Additional Input Terminals

Four additional digital input terminals can be added with the optional G5IN4 120V input card. Refer to Chapter 5; “Special Function Group, G5IN4 Digital Multi-Function Inputs” Sections (C9-XX).

Control Output

The table below summarizes the control output terminal functions.

Circuit Board	Terminal	Function
G5OUT	C	Connection to X1 of 120VAC power supply
G5OUT	01	Multi-function Output (See H2 constants)
G5OUT	02	Multi-function Output (See H2 constants)
Drive Control Board	9	Electric brake output; common
Drive Control Board	10	Electric brake output; electric brake release signal
Drive Control Board	18	Fault output—normally open; closed to COM at fault
Drive Control Board	19	Fault output—normally closed; open to COM at fault
Drive Control Board	20	Fault output—common

Wiring the Control Circuit—Procedures

To wire the drive control circuit for IMPULSE•G+ Series 2:

1. The G5IF 120V Control Voltage Interface Card is already attached to the drive control terminals when the drive is shipped. The figure is provided below in case you have to reattach this board.

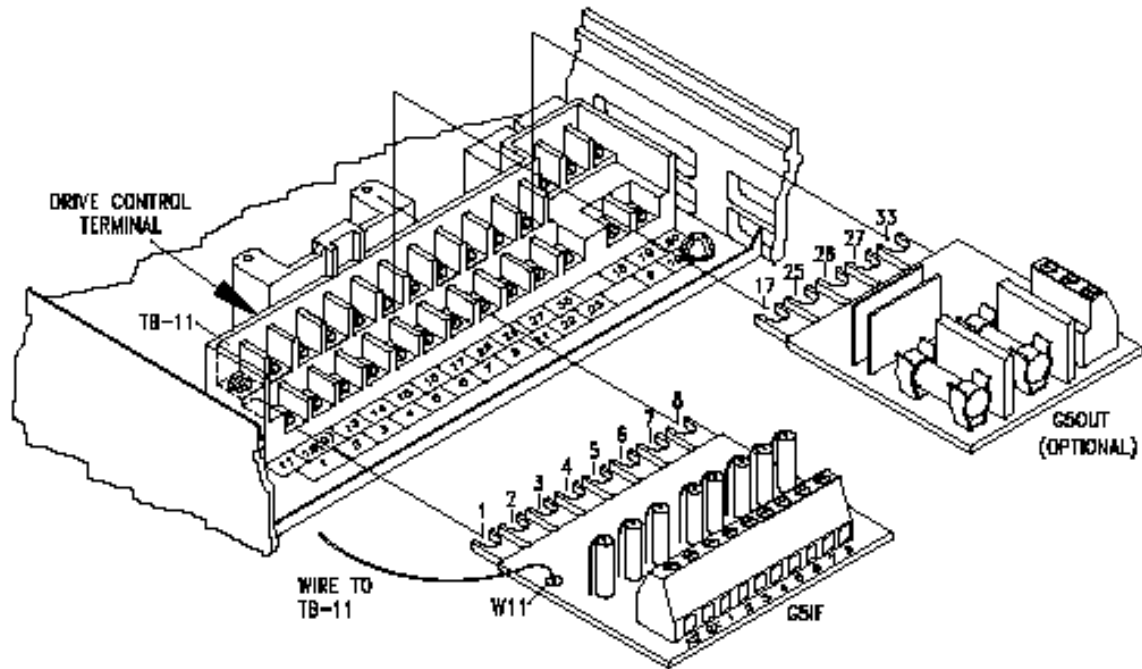

Figure 3-5: Interface Card Connections

- Connect input terminals—X2, 1, 2, 3, 4, 5, 6, 7, and 8 for G5IF and X2, 1, 2, 3 and 4 for G5IN4—to the user input device. The following drawing shows a typical five-speed interconnection and should help you understand how to wire any control circuit application. For more information on multi-function inputs, see **Terminal 3 Sel** (H1-01) through **Terminal 8 Sel** (H1-06) in Chapter 5 Terminal Parameters Group, Digital Inputs Section.

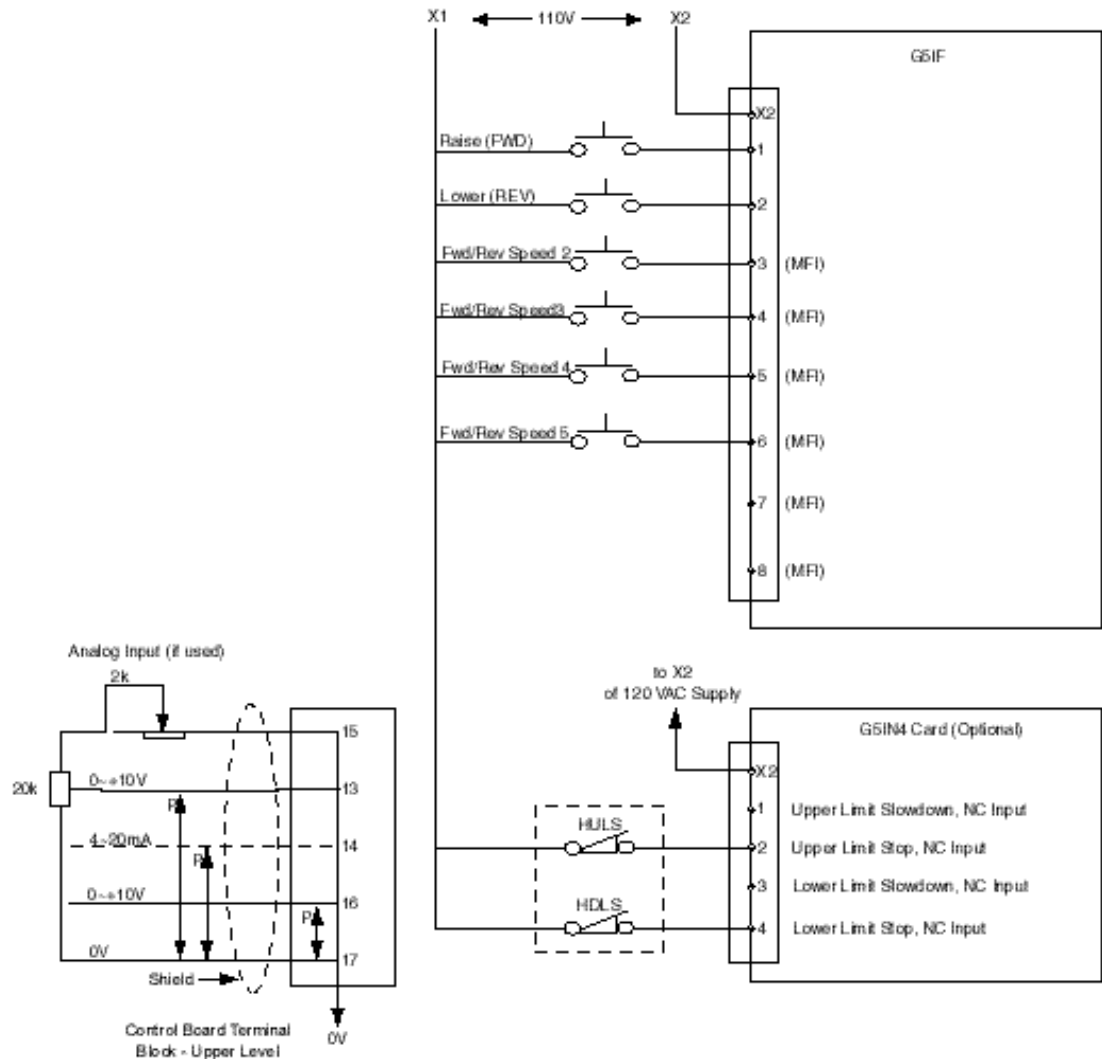

Figure 3-6: Five-Step Multi-Speed Terminal Diagram (Example)

- Install G5OUT option card to the drive as indicated on the preceding page, “Interface Card Connection.”

- Connect the output terminals, as indicated in the following drawing, to the intended output devices(s).

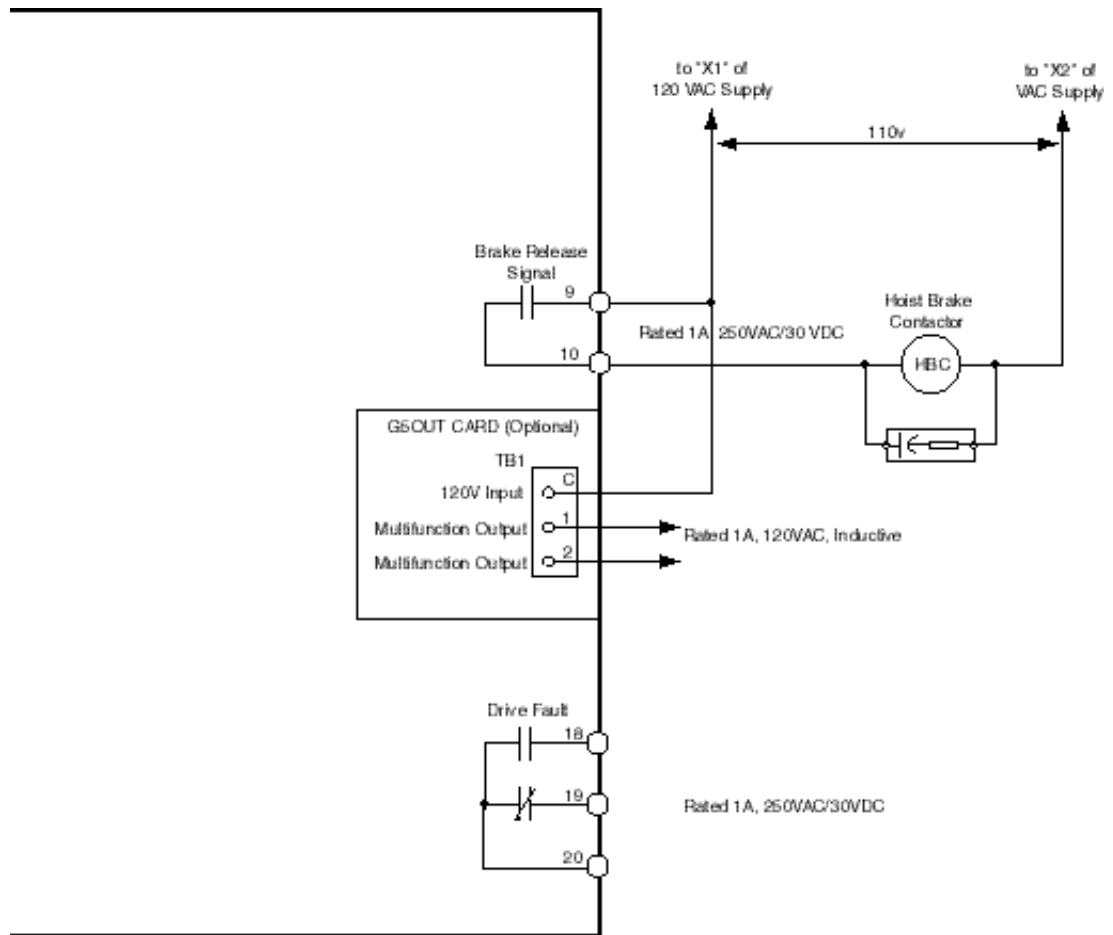

Figure 3-7: Output Terminals

- Connect the G5IF common lead (blue wire W11) to Terminal 11 on the drive control terminal. Refer to page 3-13, “Interface Card Connection.”

Control Circuit Terminals

The table below outlines the functions of the control circuit terminals.

Classification	Terminal	Signal Function	Description	Signal Level	
Sequence Input Signal	1	Forward run/stop	Forward run when closed, stop when open	Photo-coupler isolation Input: +24VDC 8mA	
	2	Reverse run/stop	Reverse run when closed, stop when open		
	3	Speed 2	Multi-function contact inputs (H1-01 to H1-06)		
	4	Speed 3			
	5	Speed 4			
	6	Speed 5			
	7	External Fault			
	8	M-Speed Gain 1			
11	Sequence control input common terminal	–			
Analog Input Signal	15	+15V Power supply output	For analog command +15V power supply	+15V (Allowable current 20 mA max.)	
	33	-15V Power supply output	For analog command -15V power supply	-15V (Allowable current 20 mA max.)	
	13	Master frequency reference	-10 to +10V/-100% to 100% 0 to +10V/0 to 100%	Multi-function analog reference (H3-01 to H3-03)	-10 to +10V (20k Ω), 0 to +10V/(20k Ω)
	14	Multi-function analog reference	4 to 20 mA/0 to 100% -10 to +10V/-100% to 100% 0 to 10 V/0 to 100%	Multi-function analog reference (H3-08 to H3-11)	4 to 20mA (250 Ω) -10 to +10V (20k Ω), 0 to +10V/(20k Ω)
	16	Multi-function analog input	-10 to +10V/-100% to +100% 0 to +10 V/0 to 100%	Auxiliary analog input (H3-04 to H3-07)	-10 to +10V (20k Ω), 0 to +10V/(20k Ω)
	17	Common terminal for control circuit	0V	–	–
	12	Connection to shield sheath of signal lead	–	–	–
Sequence Output Signal	9	Brake output	Multi-function output (H2-01 to H2-03)	Dry contact Contact capacity: 250VAC, 1A or less 30VDC, 1A or less	
	10				
	25				
	26	Fault annunciate		Open collector output 48V, 50mA or less	
	27	Open collector output common		–	
	18	Fault contact output (NO/NC contact)	Terminals 18 & 20 N/O; closed at major fault Terminals 19 & 20 N/C; open at major fault	Dry contact Contact capacity: 250VAC 1A or less 30VDC 1A or less	
	19				
20					
Analog Output Signal	21	Frequency meter output	0 to \pm 10V/0 to 100% frequency	Multi-function analog monitor (H4-01 to H4-03)	0 to \pm 11V Max. \pm 5% 2mA or less
	22	Common			
	23	Current monitor output	0 to \pm 10V/0 to 100% Inverter rated current.	Multi-function analog monitor 2 (H4-04 to H4-06)	0 to \pm 11V Max. \pm 5% 2mA or less

Surge Absorber Selection

6. Install appropriate R-C or MOV type surge absorbers across the coils of any contactors installed in the drive's control panel enclosure.

Electric Brake Coil and Reattachment

7. Connect 110VAC supply (X1) to Terminal 9, the electric brake contactor coil to Terminal 10, and the other side of the contactor coil to the 110V return (X2).
8. Reattach the G5IF card to the lower-level control board terminals.
9. Reattach the G5OUT card, if provided, to top-level control board Terminals 17, 25, 26, 27, and 33.

Cover and Keypad

10. Refasten the cover, inserting the top of the cover first.
11. Refer to Figure 3-8 to insert the keypad.

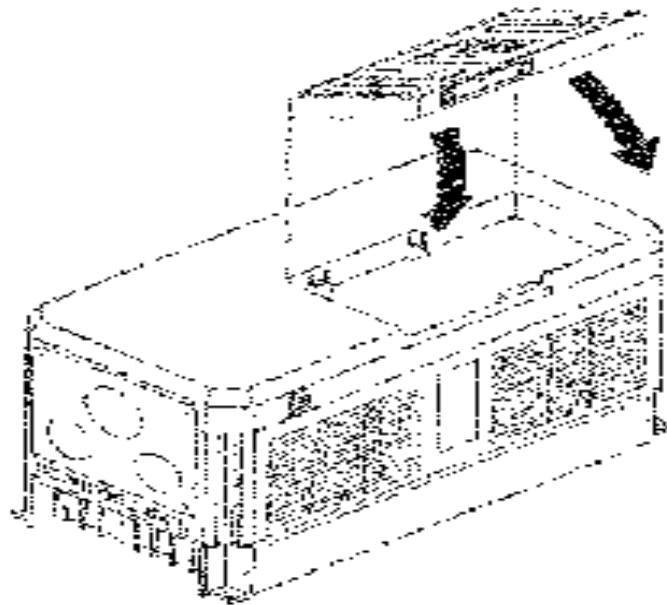

Figure 3-8: Cover and Keypad

This page intentionally left blank.

c h a p t e r **4**

Programming Basic Features

This page intentionally left blank.

Overview

With its easy-to-use keypad and X-Press Programming, IMPULSE•G+ Series 2 makes it easy to get up and running right away. In addition to explaining the keypad and X-Press Programming, this chapter explains how to view the scroll settings, get into the programming mode, and program speeds.

Checks Before Powering

After mounting and interconnections are completed, verify:

- Correct connections.
- Correct input power supply. (No voltage drop or imbalance, source kVA \leq 500, unless a line reactor is used.)



WARNING

DO not power 230V-rated drives with 460V power.

- No short circuit conditions.
- No loose screw terminals. (Check especially for loose wire clippings.)
- Proper load conditions.

Precautions

- Only start the motor if motor shaft rotation is stopped.
- Even with small loading, never use a motor whose nameplate amperage exceeds the inverter rated current.



DANGER

Braking method selection as shipped from Electromotive Systems is set for decelerate to stop. Extreme caution should be used. If deceleration time is too long, equipment could run into endstop device, causing damage to equipment or injury to personnel.

Using the Keypad

With two 16-character lines available, the English keypad display makes it possible to view fault codes and change parameter settings. Parameter settings, with their parameter codes, are displayed in most cases. In addition, the parameter description is included on the top line of the display. The keypad enables you to:

- Program the various drive parameters.
- Monitor the functions of the drive.
- Read alpha-numeric fault-diagnostic indications.
- Operate the drive using the keypad (local operation).



WARNING

Because of the additional potential hazards that are introduced when any drive is operated locally, we advise you to avoid operating it this way. If you do operate the drive locally, be aware that the crane or hoist will move when you press the RUN button. If you have questions, contact Electromotive Systems.

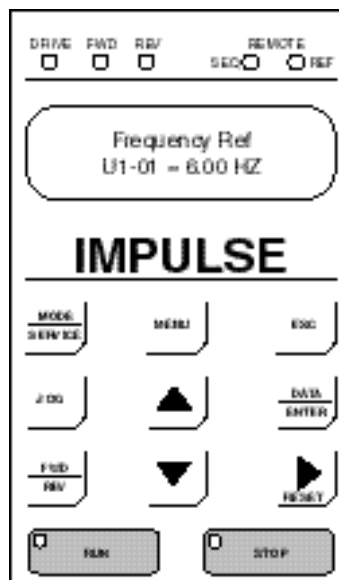

Keypad LED and Button Functions

Some of the keypad buttons, whose functions are described below, are dual-purpose. The dual-purpose keys have one function when used in a view-only mode, and another function when used in a programming mode.



This LED lights only when the drive is in the **Operation** mode, which includes when the drive is first powered up.



This LED lights when the FORWARD command is given.



This LED lights when the REVERSE command is given.



- The SEQ LED lights when selecting the RUN command from the control circuit terminals or serial communication.
- The REF LED lights when the **Speed Reference** is input through control circuit terminals or serial communication.



- Pressing this key toggles between the mode set-up display and the phone number for Electromotive Systems Service Department.
- Also toggles between REMOTE and LOCAL (Digital operator from keypad) operation when 02-1 is set to 1.



Displays to the Main Menu for mode selection.



Backs up to the previous display (before the DATA/ENTER key is depressed).



Jog run is enabled when local operation is selected.



Selects the next mode, parameter group, parameter function, parameter or parameter setting. It also increases the blinking digit of a parameter setting.



Selects the previous mode, parameter group, parameter function, parameter or parameter setting. It also decreases the blinking digit of a parameter setting.



Selects the digit—from left to right—to be changed (indicated by blinking). It also resets the operation at faults.



Selects mode, group, function or parameter. Displays each parameter's set value. By pressing this key again, the set value is entered.



Selects forward or reverse run when LOCAL operation is selected.



- Pressing this key initiates run command when LOCAL operation is selected.
- The Red LED lights steadily.



- Pressing this key initiates Base Block stop command.
- The red LED lights steadily when drive is at stop; blinks when Run command is active but output frequency reference is zero, off when drive output is controlling motor speed.

Parameters

There are hundreds of parameters that determine how the drive functions. These parameters are programmed in the drive's software as measurable values or options—both of which will be referred to in this manual as *settings*. While some of these parameters are associated with one setting, others are tied to a number of possible settings.

NOTE: The terms “constant” and “parameter” have the same meaning.

Before shipping the drive to you, we programmed initial settings in the drive's software so that most, if not all, of your crane system requirements are supported. However, if you do find it necessary to change the initial settings, we recommend that you only allow qualified crane system technicians to program the drive. This can be accomplished by using the **Password Barrier** and **Access Level** features. For more information on these security features, see Initialization Set-up on page 4-9.

You also have the option of allowing personnel with limited crane system knowledge to program only certain parameters—**User Parameters**—that you select. To select these parameters, see “User Parameters (A2-XX)” on page 4-14.

Two other features to be aware of are **Initialize Parameters (A1-05)** and **User Defaults (O2-03)**. Both these features are related, they allow you to revert back to parameter settings that you save. This is especially helpful when you have made a number of programming changes, but want to get back to the settings you had before you made any changes. To program these features, see “Initilize Parameters (A1-05)” and “User Defaults (02-03)” on pages 4-14 and 5-90, 91.

IMPULSE•G+ Series 2 Structure of Parameters

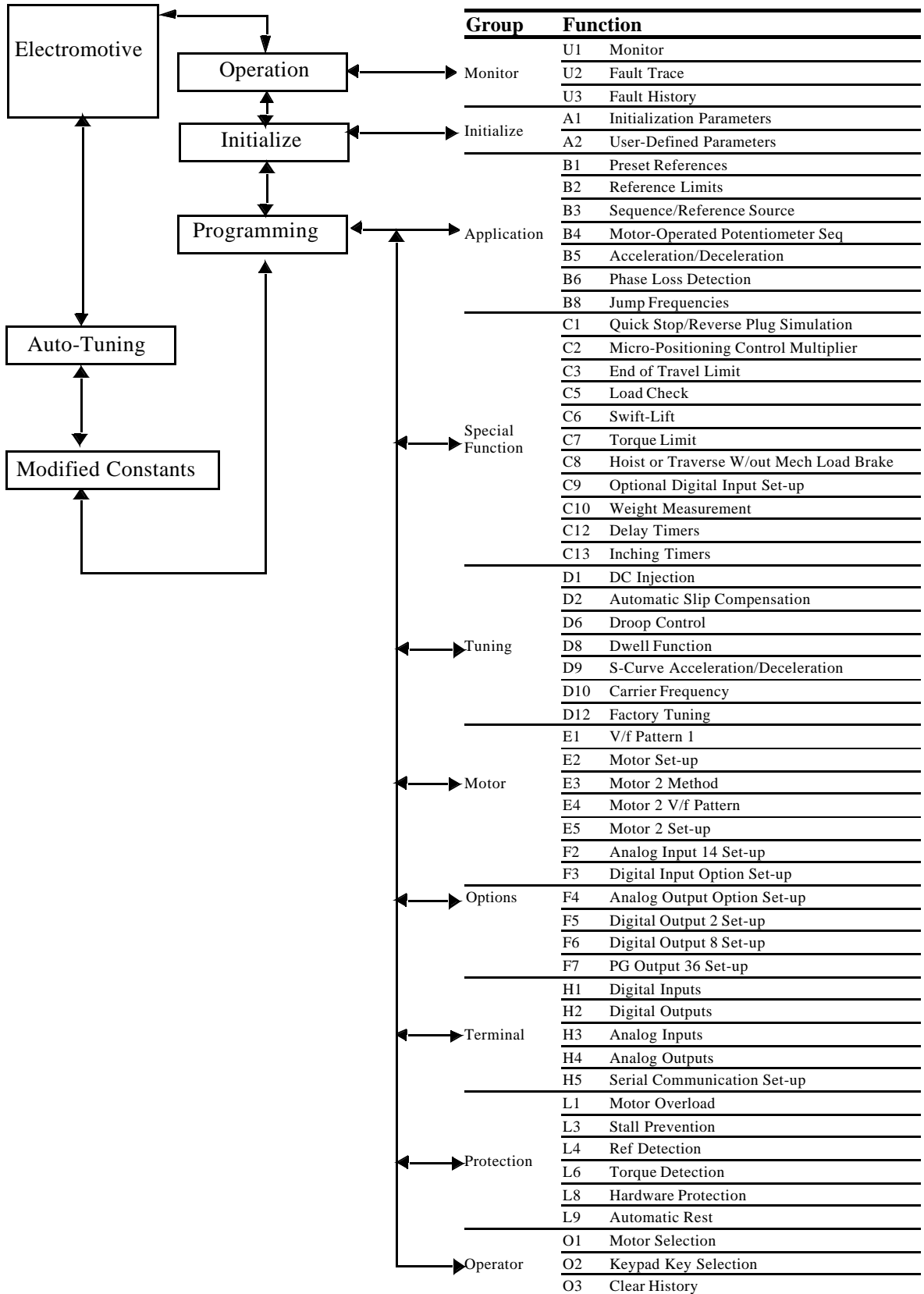

Parameter Modes

All parameters are organized under five modes:

Drive Mode

Drive operation is enabled. Drive status LED lights.

Initialize Mode

Parameter access levels, control method, motion, speed control mode, and passwords are selected.

Programming Mode

Parameters are set/read. Items to be set/read vary depending on the access level setting.

Auto-Tuning Mode

Motor parameters are automatically set by entering tuning data (motor nameplate values) when using open loop vector control method.

Modified Constants Mode

Only parameters that have been changed from the default settings are set/read.

Initialization Set-up

Parameter Access Level (A1-01)

This parameter allows the “masking” of parameters according to user level. See the following table:

Setting	Description
0	Operation Only
1	User Program - Accesses parameters selected by OEM (A2-01 to A2-32).
2	Advanced Level - For advanced programming in special applications.

Refer to the parameter code table in Chapter 5 for available parameters at each level.

Control Method Selection (A1-02)

Select the control method best suited for your application.

Setting	Description
0	V/f Control - For general purpose and multiple motor applications.
2	Open Loop Vector - For applications requiring precise speed control, quick response and higher torque at low speeds (150% torque below 1Hz). An auto-tune must be performed on open loop vector applications.

NOTE: An auto-tune must be performed for open loop vector applications. Refer to the Auto-Tuning section on page 4-15.

Select Motion (A1-03)

Set this parameter to match the motion of application. See Tables 4-1 through 4-6 for details.

Setting	Description
0	Traverse - Decelerate to stop upon removal of RUN command.
1	Standard Hoist - (Default) Immediate stop upon removal of RUN command (base-block).

Speed Reference (A1-04)

This parameter will automatically define the input terminals for the selections listed below. See tables 4-1 through 4-6 for details

Setting	Description
0	5-SPD Multi-step (default) — Defines Terminals 3-6 as speeds 2-5.
1	2-Step infinitely variable — Terminals 1 and 2 = b1-01 (Reference 1) and speed hold. Terminal 3 = Accelerate.
2	3-Step infinitely variable — Terminals 1 and 2 = b1-01 (Reference 1). Terminal 3 = Speed Hold. Terminal 4 = Accelerate.
3	Uni-polar analog — Terminals 1 and 2 = A directional input. Terminal 13 = 0-10V. Terminal 14 = 4-20mA.
4	Bi-polar analog — Terminal 13 = -10 to +10V. An input on Terminal 1 is required, but direction is determined by the reference given on Terminal 13.
5	2-SPD Multi-step — Defines Terminal 3 = 2nd speed.
6	3-SPD multi-step — Defines Terminals 3 and 4 as speeds 2 and 3 respectively.
7	Not Used—Defines terminals 3-8 as not used. Use this setting if using the G5IN4 option card for inputting speed references.

Parameters Changed by X-Press Programming

Table 4-1: A1-03=Traverse

	Parameter	Description	B1-01	B1-02	B1-03	B1-04	B1-05	B1-06*	B1-07*	B1-08*	B1-09	B1-10
			Speed 1	Speed 2	Speed 3	Speed 4	Speed 5	Speed 6	Speed 7	Speed 8	Jog Reference	Reference Priority
A1-04	A1-04	5-Speed Multi-Step	6.00	15.00	30.00	45.00	60.00	9999	9999	9999	6.00	0
	A1-04	2-Step Infinitely Variable	6.00	9999	9999	9999	60.00	9999	9999	9999	6.00	0
	A1-04	3-Step Infinitely Variable	6.00	9999	9999	9999	60.00	9999	9999	9999	6.00	0
	A1-04	Uni-Polar Analog	9999	9999	9999	9999	9999	9999	9999	9999	6.00	1
	A1-04	Bi-Polar Analog	9999	9999	9999	9999	9999	9999	9999	9999	6.00	1
	A1-04	2-Speed Multi-Step	20.00	60.00	9999	9999	9999	9999	9999	9999	6.00	0
	A1-04	3-Speed Multi-Step	15.00	30.00	60.00	9999	9999	9999	9999	9999	6.00	0
	A1-04	Not Used	15.00	30.00	60.00	9999	9999	9999	9999	9999	6.00	0

*Applies only for software versions 14910 and 14911.

Note: Data 9999 denotes no change from previously programmed value.

Table 4-2: A1-03=Traverse (Continued)

	Parameter	Description	B2-01	B2-02	B3-03	B5-01*	B5-02*	C1-01*	D9-01*	D9-02*	D9-03*	E1-02	E1-03
			Ref. Upper Limit	Ref. Lower Limit	Stopping Method	Accel Time 1	Decel Time 1	Quick Stop 0/1	S-Curve Accel at Start	S-Curve Accel at End	S-Curve Decel at Start	Motor Selection	V/F Selection
A1-04	A1-04	5-Speed Multi-Step	100.00	2.0	0	5.0	5.0	0	1.50	1.50	1.50	0	00
	A1-04	2-Step Infinitely Variable	100.00	2.0	0	5.0	5.0	0	1.50	1.50	1.50	0	00
	A1-04	3-Step Infinitely Variable	100.00	2.0	0	5.0	5.0	0	1.50	1.50	1.50	0	00
	A1-04	Uni-Polar Analog	100.00	2.0	0	5.0	5.0	0	1.50	1.50	1.50	0	00
	A1-04	Bi-Polar Analog	100.00	2.0	0	5.0	5.0	0	1.50	1.50	1.50	0	00
	A1-04	2-Speed Multi-Step	100.00	2.0	0	5.0	5.0	0	1.50	1.50	1.50	0	00
	A1-04	3-Speed Multi-Step	100.00	2.0	0	5.0	5.0	0	1.50	1.50	1.50	0	00
	A1-04	Not Used	100.00	2.0	0	5.0	5.0	0	1.50	1.50	1.50	0	00

* Applies only for software versions 14910 and 14911.

Table 4-3: A1-03=Traverse (Continued)

	Parameter	Description	H1-01	H1-02	H1-03	H1-04	H1-05	H1-06	H2-01	H2-02	H2-03	H3-01
			Terminal 3 Select	Terminal 4 Select	Terminal 5 Select	Terminal 6 Select	Terminal 7 Select	Terminal 8 Select	Terminal 9 Select	Terminal 25 Select	Terminal 26 Select	Terminal 13 Signal
A1-04	A1-04	5-Speed Multi-Step	00	01	02	03	24	0E	00	00	7F	0
	A1-04	2-Step Infinitely Variable	05	07	09	13	24	0E	00	00	7F	0
	A1-04	3-Step Infinitely Variable	04	05	07	09	24	0E	00	00	7F	0
	A1-04	Uni-Polar Analog	07	09	13	16	24	0E	00	00	7F	0
	A1-04	Bi-Polar Analog	07	09	13	16	24	0E	00	00	7F	1
	A1-04	2-Speed Multi-Step	00	07	09	13	24	0E	00	00	7F	0
	A1-04	3-Speed Multi-Step	00	01	07	09	24	0E	00	00	7F	0
	A1-04	Not Used	0F	0F	0F	0F	0F	0F	00	00	7F	0

Table 4-4: A1-03=Standard Hoist

	Parameter	Description	B1-01	B1-02	B1-03	B1-04	B1-05	B1-06*	B1-07*	B1-08*	B1-09	B1-10
			Speed 1	Speed 2	Speed 3	Speed 4	Speed 5	Speed 6	Speed 7	Speed 8	Jog Reference	Reference Priority
A1-04	A1-04	5-Speed Multi-Step	6.00	15.00	30.00	45.00	60.00	9999	9999	9999	6.00	0
	A1-04	2-Step Infinitely Variable	6.00	9999	9999	9999	60.00	9999	9999	9999	6.00	0
	A1-04	3-Step Infinitely Variable	6.00	9999	9999	9999	60.00	9999	9999	9999	6.00	0
	A1-04	Uni-Polar Analog	9999	9999	9999	9999	9999	9999	9999	9999	6.00	1
	A1-04	Bi-Polar Analog	9999	9999	9999	9999	9999	9999	9999	9999	6.00	1
	A1-04	2-Speed Multi-Step	20.00	60.00	9999	9999	9999	9999	9999	9999	6.00	0
	A1-04	3-Speed Multi-Step	15.00	30.00	60.00	9999	9999	9999	9999	9999	6.00	0
	A1-04	Not Used	15.00	30.00	60.00	9999	9999	9999	9999	9999	6.00	0

* Applies only for software versions 14910 and 14911.

NOTE: Data 9999 denotes no change from previously programmed value.

Table 4-5: A1-03=Standard Hoist (Continued)

Parameter	Description	B2-01	B2-02	B3-03	B5-01*	B5-02*	C1-01*	D9-01*	D9-02*	D9-03*	E1-02	E1-03	
		Ref. Upper Limit	Ref. Lower Limit	Stopping Method	Accel Time 1	Decel Time 1	Quick Stop 0/1	S-Curve Accel at Start	S-Curve Accel at End	S-Curve Decel at Start	Motor Selection	V/F Selection	
A1-04	A1-04	5-Speed Multi-Step	100.00	2.0	1	5.0	3.0	0	.50	.50	.50	0	04
	A1-04	2-Step Infinitely Variable	100.00	2.0	1	5.0	3.0	0	.50	.50	.50	0	04
	A1-04	3-Step Infinitely Variable	100.00	2.0	1	5.0	3.0	0	.50	.50	.50	0	04
	A1-04	Uni-Polar Analog	100.00	2.0	1	5.0	3.0	0	.50	.50	.50	0	04
	A1-04	Bi-Polar Analog	100.00	2.0	1	5.0	3.0	0	.50	.50	.50	0	04
	A1-04	2-Speed Multi-Step	100.00	2.0	1	5.0	3.0	0	.50	.50	.50	0	04
	A1-04	3-Speed Multi-Step	100.00	2.0	1	5.0	3.0	0	.50	.50	.50	0	04
	A1-04	Not Used	100.00	2.0	1	5.0	3.0	0	.50	.50	.50	0	04

* Applies only for software versions 14910 and 14911.

Table 4-6: A1-03=Standard Hoist (Continued)

Parameter	Description	H1-01	H1-02	H1-03	H1-04	H1-05	H1-06	H2-01	H2-02	H2-03	H3-01	
		Terminal 3 Select	Terminal 4 Select	Terminal 5 Select	Terminal 6 Select	Terminal 7 Select	Terminal 8 Select	Terminal 9 Select	Terminal 25 Select	Terminal 26 Select	Terminal 13 Signal	
A1-04	A1-04	5-Speed Multi-Step	00	01	02	03	24	0E	00	00	7F	0
	A1-04	2-Step Infinitely Variable	05	07	09	13	24	0E	00	00	7F	0
	A1-04	3-Step Infinitely Variable	04	05	07	09	24	0E	00	00	7F	0
	A1-04	Uni-Polar Analog	07	09	13	16	24	0E	00	00	7F	0
	A1-04	Bi-Polar Analog	07	09	13	16	24	0E	00	00	7F	1
	A1-04	2-Speed Multi-Step	00	07	09	13	24	0E	00	00	7F	0
	A1-04	3-Speed Multi-Step	00	01	07	09	24	0E	00	00	7F	0
	A1-04	Not Used	0F	0F	0F	0F	0F	0F	00	00	7F	0

Initial Parameters (A1-05)

Use this parameter to reset the inverter to its factory default settings.

Setting	Description
0	No Initialization (factory default)
1110	User Initialization - resets the inverter to user-specified initial values. To set user-specified initial values, make all required changes to parameter settings, then set 02-03 to "1". The inverter will memorize all current settings as the user-specified initial values. Up to 50 changed parameters can be stored.

Password Entry (A1-06)

This parameter will enable the user to set a password that will inhibit the programming of the *A1-01* to *A1-03* parameters. This function is useful when used in conjunction with the access level parameter *A1-01*. To set the password, press the MENU and RESET buttons at the same time and the display will change from *A1-06* to *A1-07*. Program in a password number, then when *A1-06* is not the same as *A1-07* parameter *A1-01* to *A1-03* cannot be changed. When *A1-06* is the same as *A1-07*, then *A1-01* to *A1-03* can be changed.

User Parameters (A2-01 through 30)

The user can select up to 30 parameters for quick-access programming. By setting the user access level (*A1-01*) to "User Program", only the parameters selected in function A2 can be accessed by the user. To assign a parameter as a user parameter go to the A2 level in the initialize menu. Once the A2 parameters are set and *A1-01* is programmed to "User Program", only the parameters visible in the program menu will be the ones assigned to an A2 parameter.

Auto-Tuning



CAUTION

The brake output is not energized during auto-tune. The brake must be manually released and unreleased when Auto-Tuning is complete.



WARNING

Auto-tuning should only be performed on a motor that is not coupled to a gearbox.

The IMPULSE•G+ can adapt to all motors manufactured worldwide with its automatic tuning function. Available in Open Loop Vector control only (A1-02=2), the inverter asks the user for minimal motor information, then guides the user through a quick simple tuning process. Refer to the Structure of Parameters on page 4-7 and the table below for the motor data required for automatic tuning.

NOTE: Contact Factory if an auto-tune can not be performed.

Display	Description	Default Setting
Rated Voltage	Sets motor rated voltage in VAC	KVA dependent
Rated Current	Sets motor rated current in Amps	KVA dependent
Rated Frequency	Sets motor rated frequency in Hertz	60.0 Hz
Rated Speed	Sets motor rated speed in RPM	1750 RPM
Number of Poles	Sets the number of motor poles	4
Select Motor	Selects between motor 1 or 2	1

After scrolling through the tuning parameters using the Up Arrow key, depress the RUN key to begin auto-tuning. During tuning, “Tuning Proceeding” flashes on the digital operator display. When complete, “Tune Successful”, is displayed. Depress the Menu key to exit auto-tuning mode. Please refer to the “Fault Display and Corrective Actions at Auto-Tuning” section on page 6-10 if “Tune Successful” is not displayed.

NOTE: If the STOP key is depressed during tuning, auto-tuning is interrupted and the motor coasts to a stop. The data changed during tuning returns to its original values. If an auto-tune is unsuccessful, temporarily change D12-30=1 and D10-01 to at least 5.0KHz

This page intentionally left blank.

c h a p t e r **5**

**Programming Advanced
Features**

This page intentionally left blank.

Application

- B1 Preset References
- B2 Reference Limits
- B3 Sequence/Reference Source
- B4 Trim Control Level
- B5 Acceleration/Deceleration
- B6 Phase Loss Detection
- B8 Jump Frequencies

Preset Reference

Parmtr Code	Display	Function	Range	Initial Value	V/F Access	Open Loop Vector Access
B1-01*	Reference 1	Sets the frequency of Minimum Speed/Speed 1.	0.00–150.00 Hz	15	Adv	Adv
B1-02*	Reference 2	Sets the Speed 2 frequency.	0.00–150.00 Hz	30	Adv	Adv
B1-03*	Reference 3	Sets the Speed 3 frequency.	0.00–150.00 Hz	60	Adv	Adv
B1-04*	Reference 4	Sets the Speed 4 frequency.	0.00–150.00 Hz	45	Adv	Adv
B1-05*	Reference 5	Sets the Speed 5 frequency.	0.00–150.00 Hz	60	Adv	Adv
B1-06**	*Reference 6	Sets the Speed 6 frequency.	0.00–150.00 Hz	0.0	Adv	Adv
B1-07**	*Reference 7	Sets the Speed 7 frequency.	0.00–150.00 Hz	0.0	Adv	Adv
B1-08**	*Reference 8	Sets the Speed 8 frequency.	0.00–1560.00 Hz	0.0	Adv	Adv
B1-09*	Jog Reference	Jog Control and Inching Control frequency reference.	0.00–150.00 Hz	6	Adv	Adv
B1-10*	Ref Priority	Determines whether the digital or analog frequency reference is used.		0	Adv	Adv
	0	Digital Ref Only				
	1	Analog Ref Only				
	2	Higher Ref Sel				

* Initial value is determined by X-Press Programming tables 4-1 through 4-6.

** Applies only for software versions 14910 and 14911—Refer to table 5.1

Table 5.1: 1-9 Step Multi-Step (Software Versions 14910 and 14911)

Speed Reference	Forward/Reverse	Multi-Step Speed 2	Multi-Step Speed 3	Multi-Step Speed 4	Multi-Step Speed 5
STOP	0	—	—	—	—
B1-01	1	0	0	0	0
B1-02	1	1	0	0	0
B1-03	1	1	1	0	0
B1-04	1	1	1	1	0
B1-05	1	1	1	1	1
B1-06	1	0	1	0	0
B1-07	1	0	1	1	0
B1-08	1	0	0	1	0
B1-09	1	1	0	1	0

0 = Open or Not Selected

1 = Closed

— = Not Applicable

Reference Limits

These parameters will limit the frequency range as a percentage of maximum output frequency (E1-04). However, if the lower limit is below the zero speed level (D1-01), then operation will continue according to B3-05.

An alternate upper limit frequency can be used during operation when a Multi-Function Input (MFI) is set to 43 (Alt S-Ref UpLimit) and the MFI is on. Alternate Upper Limit Frequency = (B2-03)% x (E1-04).

Parmtr Code	Display	Function	Range	Initial Value	V/F Access	Open Loop Vector Access
B2-01	Ref Upper Limit	Sets as a percentage of the maximum output frequency (E1-04), which determines the maximum frequency at which the drive is able to run.	0.0–110%	100	Adv	Adv
B2-02	Ref Lower Limit	Sets as a percentage of the maximum output frequency (E1-04), which determines the minimum frequency at which the drive is able to run.	0.0–109%	2	Adv	Adv
B2-03	Upper Lim Gain	A multiplier, sets an alternate upper limit frequency by a multi-function input = 43	0–255%	100	Adv	Adv

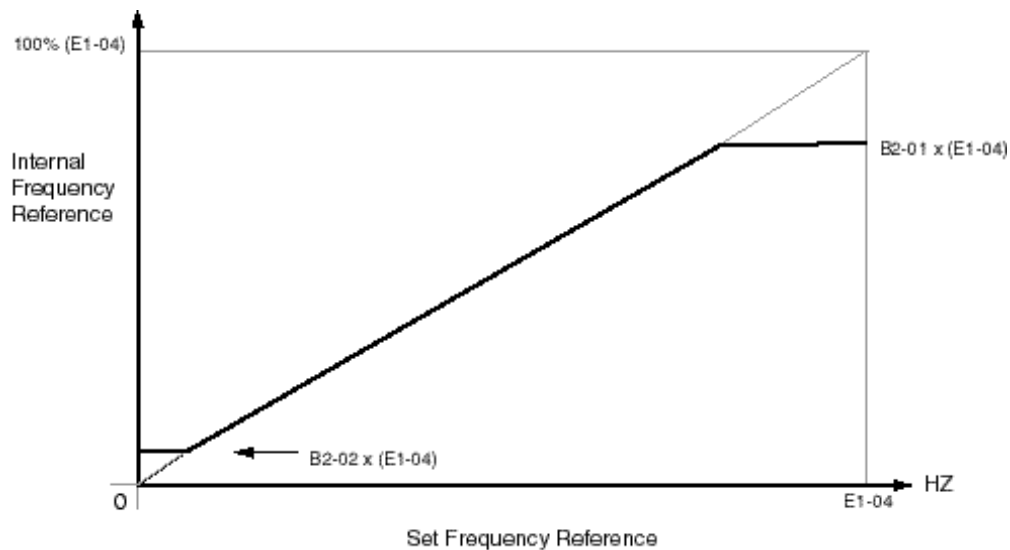

Figure 5-1: Setting Frequency Upper and Lower Limits

Sequence/Reference Source

B3-01 and B3-02 determine the source from where the frequency reference and RUN command are generated.

Parmtr Code	Display	Function	Range	Initial Value	V/F Access	Open Loop Vector Access
B3-01	Reference Source	Source from where the frequency reference is generated.		1	Adv	Adv
	0 Operator	Digital operator (keypad).				
	1 Terminals	Control circuit terminal. (G5IF Card)				
	2 Serial Com	Serial communication (Port 6CN).				
	3 Option PCB	Optional card (Port 2CN).				
B3-02	Run Source	Source from where the RUN command is generated.		1	Adv	Adv
	0 Operator	Digital operator (keypad).				
	1 Terminals	Control circuit terminal. (G5IF Card)				
	2 Serial Com	Serial communication (Port 6CN).				
	3 Option PCB	Optional card (Port 2CN).				

Stop Method

B3-03 selects the stopping method suitable for the particular application.

Parmtr Code	Display	Function	Range	Initial Value	V/F Access	Open Loop Vector Access
B3-03	Stop Method	Determines stop method.		*	Adv	Adv
	0 Ramp to Stop (A1-03=0)	(Figure 5-2)				
	1 Coast to Stop (A1-03=1)	(Figure 5-3)				
	2 DC Inj to Stop	(Figures 5-4 and 5-5)				
	3 Coast w/Timer	(Figure 5-6)				
	4 Ramp w/Timer (Traverse mode only)	(Figure 5-7)				
	5 Hoist 2-Stop	(Figure 5-8)				

* Initial value is determined by X-Press Programming tables 4-1 through 4-6.

Ramp to Stop (B3-03=0)

Upon removal of the FWD or REV run command, the motor decelerates at a rate determined by the time set in deceleration time 1 (B5-02) and DC injection braking is applied after the DC injection start frequency (D1-01) has been reached. If the deceleration time is set too short or the load inertia is large, an overvoltage fault (OV) may occur during deceleration. In this case, increase the deceleration time or install an optional braking transistor and/or braking resistor.

Braking torque: without braking resistor, approximately 20% of motor rated torque; with braking option, approximately 150% of motor rated torque.

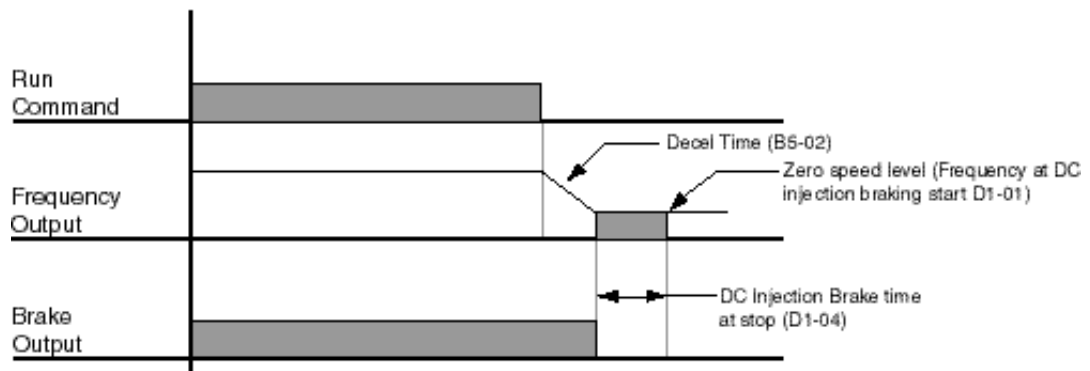

Figure 5-2: Ramp to Stop

Coast to Stop (B3-03=1)

Upon removal of the FWD or REV run command, the motor starts to coast and the electric brake sets.

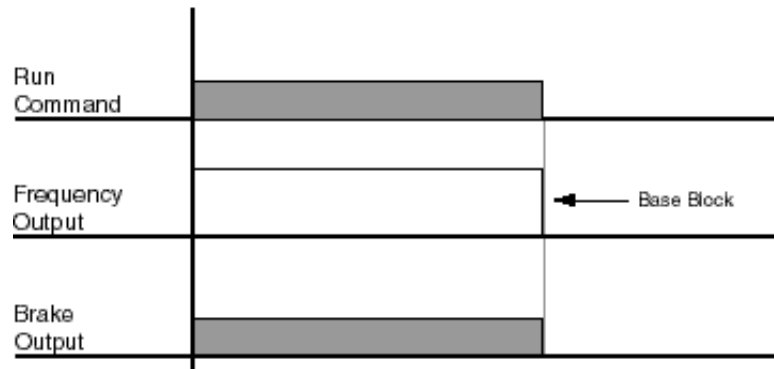

Figure 5-3 Coast to Stop

DC Injection to Stop (B3-03=2)

Upon removal of the FWD or REV run command, the motor brakes to stop, according to the DC injection braking time at stop set in D1-04. If the value is set to "0", DC injection braking is disabled, and the motor coasts to stop. When choosing this function, note that the DC injection braking time is the time set in D1-04 multiplied by 10 (see below, Figures 5-4 and 5-5). Braking duty cycle should allow excess motor heat to dissipate.

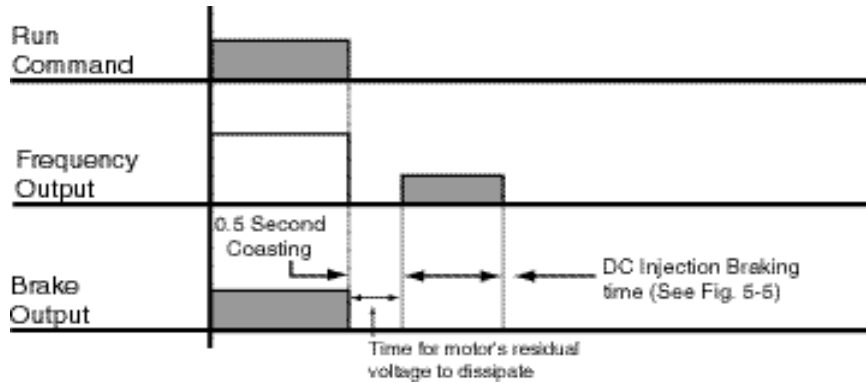

Figure 5-4: DC Injection to Stop

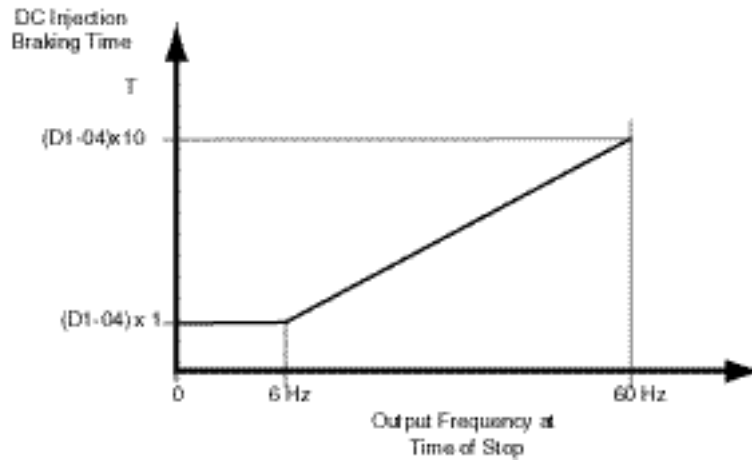

Figure 5-5: DC Injection Time

Coast to Stop w/Timer (B3-03=3)

After a stop command is given, a run command is not accepted while the coast to stop timer elapses. After the timer runs out, another run command must be given for the drive to begin acceleration. The coast to stop timer is the time set in B5-02 multiplied by the output frequency percent of E1-04 at time of stop.

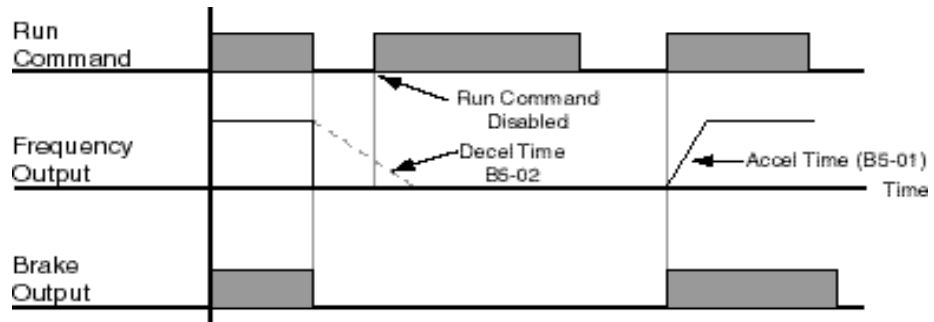

Figure 5-6: Coast w/Timer

Ramp w/Timer (B3-03=4)

(This option is only available in traverse motion). Upon run command removal, the motor decelerates to stop. The brake delays for a time interval (C12-02) before it is set. This option reduces brake wear for applications that involve frequent stopping and starting.

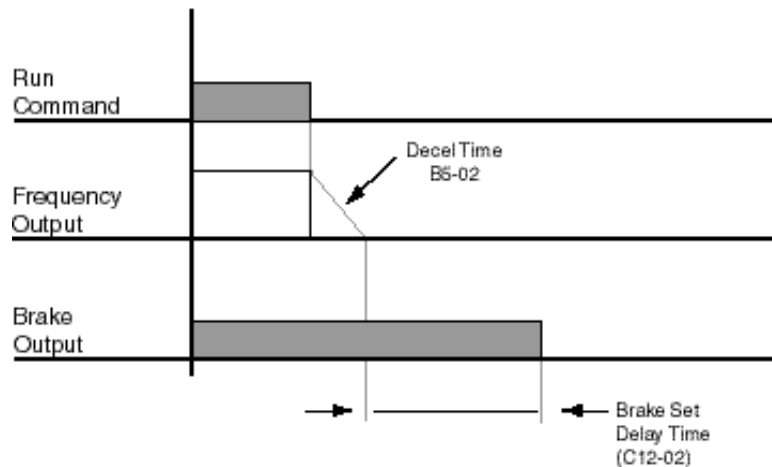

Figure 5-7: Ramp w/Timer

Hoist 2-Stop (B3-03=5) Mechanical Load Brake Hoists

This sequence allows deceleration to stop at stop command when lowering (reverse operation) and immediate stop at stop command when raising (forward operation). The Multi-Function output for brake operation must be programmed to 3B: During Run 1 (H2-01=3B).

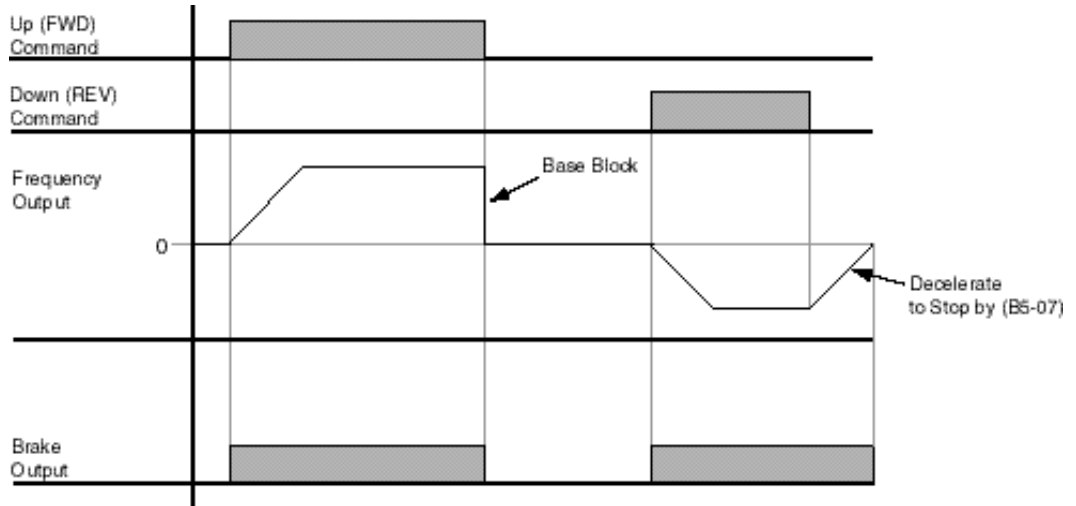

Figure 5-8: Hoist 2-Stop

Input Scan Time

B3-06 selects the microprocessor scan time for reading sequence input data from the control circuit terminals. Set B3-06 to “0” when a quicker response is needed from the control circuit terminal.

Parmtr Code	Display	Function	Range	Initial Value	V/F Access	Open Loop Vector Access
B3-06	# of Input Scans	Selects the microprocessor scan time		1	Adv	Adv
	0 <i>2ms–2 scans</i>					
	1 <i>5ms–2 scans</i>					

LOC/REM Run Select

If the run reference/speed reference are switched between serial mode and drive terminal mode, B3-07 determines action after the switch.

Parmtr Code	Display	Function	Range	Initial Value	V/F Access	Open Loop Vector Access
B3-07	LOC/REM Run Sel	Determines action after switching Run/Speed reference source.		0	Adv	Adv
	0 <i>Cycle Extrn Run</i>	If the run command is present at the time when the Run/Speed reference source is switched, it requires the run command to be removed and then reapply the run command from the new source to resume the normal operation.				
	1 <i>Accep Extrn Run</i>	If the run command is present at the time when the Run/Speed reference source is switched, it does not require the run command from the new source to be removed. The normal operation will continue.				

Trim Control Level

The trim control level is valid when the trim control increase command (setting: 1C) or trim control decrease command (setting: 1D) is set for a multi-function input (H1-01 to H1-06).

If the trim control increase command is ON when a frequency reference is input on the analog input, the trim control level will be added to the analog frequency reference and then output as the output frequency. If the trim control decrease command is ON, the frequency reference will be decreased by the trim control level.

Parmtr Code	Display	Function	Range	Initial Value	V/F Access	Open Loop Vector Access
B4-02	Trim Control LVL	Sets Trim Control speed level	0-100%	10	Adv	Adv

Set the trim control level as a percentage of the maximum output frequency.

If the frequency reference minus the trim control level is less than zero, the output frequency will be zero.

Acceleration/Deceleration

Acceleration time sets the time necessary for the output frequency to accelerate from 0Hz to maximum output frequency (E1-04). Deceleration time sets the time necessary for the output frequency to decelerate from the maximum output frequency (E1-04) to 0Hz.

Parmr Code	Display	Function	Range	Initial Value	V/F Access	Open Loop Vector Access
B5-01	*Accel Time 1	Sets acceleration time.	0.0–25.5 sec	5.0	Adv	Adv
B5-02	*Decel Time 1	Sets deceleration time.	0.0–25.5 sec	3.0	Adv	Adv
B5-03	Accel Time 2	Sets alternate accel. time. Enabled by multi-function input=1B.	0.0–25.5 sec	1.0	Adv	Adv
B5-04	Decel Time 2	Sets alternate decel. time. Enabled by multi-function input=1B.	0.0–25.5 sec	1.0	Adv	Adv

* Initial value is determined by X-Press Programming tables 4-1 through 4-6.

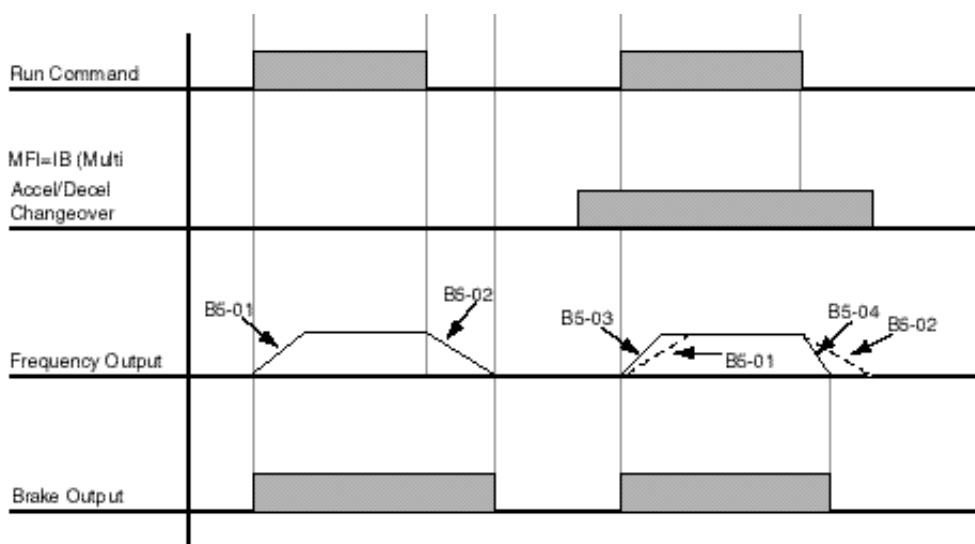

NOTE: Assume the constant B3-03 is set to "0" (Ramp to Stop).

Figure 5-9: Normal Accel/Decel Time and Multiple Accel/Decel Changeover

Accel/Decel Time Switching Frequency

Accel/Decel times can be changed automatically without using multi-function inputs. (See Figures 5-10 and 5-11 on next page). When multi-function contact inputs are set for Accel/Decel selection, this command has priority over automatic change of Accel/Decel.

Parmtr Code	Display	Function	Range	Initial Value	V/F Access	Open Loop Vector Access
B5-05	Accel Time N Chg	Sets acceleration time at Speed Switch frequency.	0.0–25.5 sec	1.0	Adv	Adv
B5-06	Dec Time N Chg	Sets deceleration time at Speed Switch frequency.	0.0–25.5 sec	1.0	Adv	Adv
B5-07	Hoist 2 Stop	Sets deceleration time for DOWN/REVERSE direction, when B3-03=5 (Hoist 2-Stop).	0.0–25.5 sec	0.3	Adv	Adv
B5-08	Fault Stop Time	Sets deceleration time for complete stop at external fault. See External Fault Response Selection on page 5-67.	0.0–25.5 sec	0.3	Adv	Adv
B5-09	Acc/Dec Units	Determines acceleration and deceleration time interval and range.		1	Adv	Adv
	<i>0</i>	<i>0.01sec for 0.00–2.55 sec</i>				
	<i>1</i>	<i>0.1sec for 0.0–25.5</i>				
B5-10	Acc/Dec SW Freq	Determines acceleration/ deceleration switching level.	0.0–150.0Hz	120.0	Adv	Adv
B5-11	SW Freq Compare	Determines when Acceleration Time and Deceleration Time at Speed Switch Hz is enabled;		1	Adv	Adv
	<i>0</i>	<i>lower SW Freq</i>	0: B5-05/06 is enabled, N-out ≤ B5-10			
	<i>1</i>	<i>upper SW Freq</i>	1: B5-05/06 is enabled, N-out ≥ B5-10			

NOTE: N=Internal Frequency

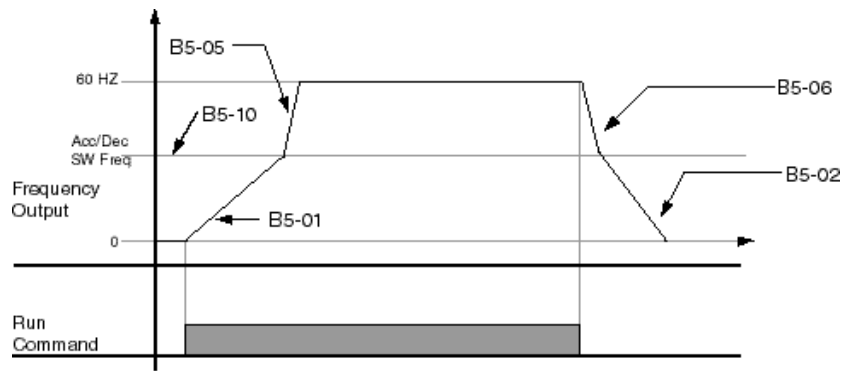

Figure 5-10: When B5-11=1 (Upper Switch Frequency)

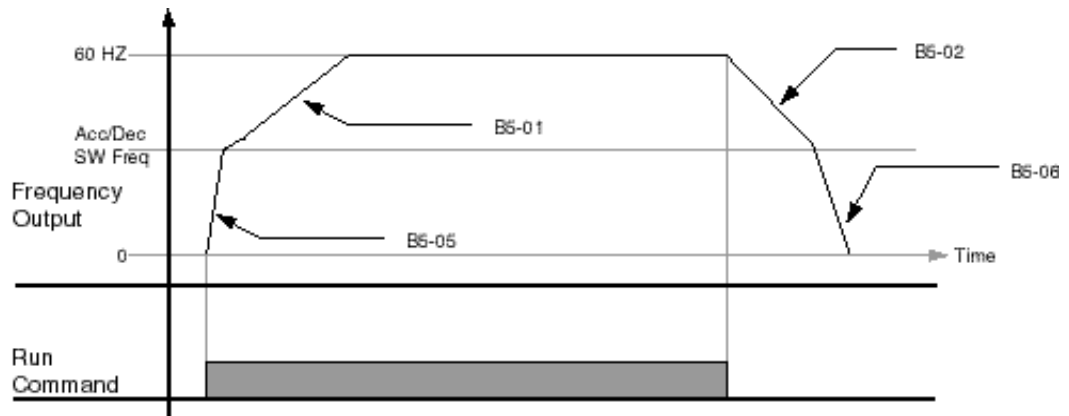

Figure 5-11: When B5-11=0 (Lower Switch Frequency)

Torque Limit Accel/Decel

Determines Accel/Decel times when the multi-function input is = 14 (Torque Limit Accel/Decel).

Parmtr Code	Display	Function	Range	Initial Value	V/F Access	Open Loop Vector Access
B5-12	For T Lim Accel	Determines acceleration time at FORWARD when Torque Limit Acc/Dec is multi-function input = 14.	0.0–25.5 sec	0	Adv	Adv
B5-13	For T Lim Decel	Determines deceleration time at FORWARD when Torque Limit Acc/Dec is multi-function input = 14.	0.0–25.5 sec	0	Adv	Adv
B5-14	Rev T Lim Accel	Determines acceleration time at REVERSE when Torque Limit Acc/Dec is multi-function input = 14.	0.0–25.5 sec	0.5	Adv	Adv
B5-15	Rev T Lim Decel	Determines deceleration time at REVERSE when Torque Limit Acc/Dec is multi-function input = 14.	0.0–25.5 sec	0	Adv	Adv

Phase Loss Detection

Input Phase Loss Detection is provided to protect the main power rectifiers and capacitors in the IMPULSE•G+ Series 2. If any of the three-phase input lines are lost, the DC Bus capacitors and rectifiers suffer approximately a 40% increase in current. This increase will cause a ripple on the DC Bus voltage. If this ripple becomes too great, the drive automatically shuts down and displays a fault code “PF”.

Phase Loss Detection compares the output current of each of the three phases to a preset level. If the output current of any of the phase falls below the preset level, a “LF” fault will appear on the display. The drive will immediately set the brake, thus retaining control of the load.

Parmtr Code	Display	Function	Range	Initial Value	V/F Access	Open Loop Vector Access
B6-01	Ph Loss In Sel <i>0 Disabled</i> <i>1 Enabled</i>	Determines whether Phase Loss Detection Input is enabled.		0	Adv	Adv
B6-02	Ph Loss In Lvl	Determines Phase Loss Detection Input Level.	0.0–25.0%	7.5	Adv	Adv
B6-03	Ph Loss Out Sel <i>0 Disabled</i> <i>1 Enabled</i>	Determines whether Phase Loss Detection Output is enabled.		1	Adv	Adv
B6-04	Ph Loss Out Lvl	Determines Phase Loss Detection Output level.	0.0–20.0%	5.0	Adv	Adv

Jump Frequencies

This function allows the “jumping” of critical frequencies so that the motor can operate without resonant vibrations caused by some machine systems. This function is also used for deadband control. Setting the value to 0.0 Hz disables this function.

Parmr Code	Display	Function	Range	Initial Value	V/F Access	Open Loop Vector Access
B8-01	Jump Freq 1	First of three jump frequencies.	0.0–150.0 Hz	0	Adv	Adv
B8-02	Jump Freq 2	Second of three jump frequencies.	0.0–150.0 Hz	0	Adv	Adv
B8-03	Jump Freq 3	Third of three jump frequencies.	0.0–150.0 Hz	0	Adv	Adv
B8-04	Jump Bandwidth	Jump frequency reference bandwidth.	0.0–20.0 Hz	1.0	Adv	Adv

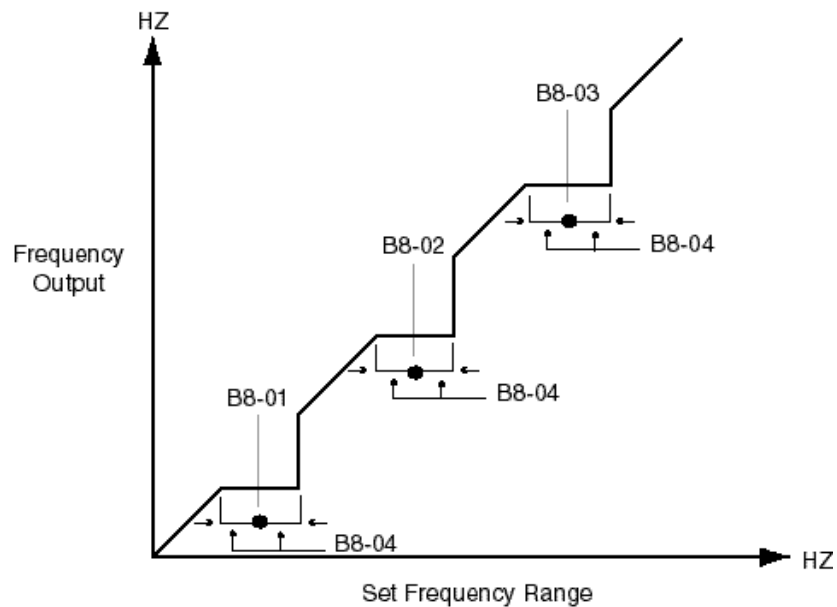

Figure 5-12: Jump Frequencies

Special Functions

- C1 Quick Stop/Reverse Plug Simulation
- C2 Micro-Positioning Control Multiplier
- C3 End of Travel Limit
- C5 Load Check
- C6 Swift-Lift
- C7 Torque Limit (for Open loop vector only)
- C9 Optional Digital Input Set-up
- C12 Delay Timers
- C13 Inching Timers

Special Function	Motion (A1-03)			
	Traverse (A1-03=0)		Standard Hoist (A1-03=1)	
	V/F	OLV	V/F	OLV
C1:Reverse Plug Simulation/Quick Stop	Yes	Yes	Yes	Yes
C2:Micro-Positioning Control Multiplier	Yes	Yes	Yes	Yes
C3:End of Travel Limit	Yes	Yes	Yes	Yes
C5:Load Check	N/A	N/A	Yes	Yes
C6:Swift Lift	N/A	N/A	Yes	Yes
C7:Torque Limit	No	Yes	No	Yes
C9:Optional Digital Input Set-up	Yes	Yes	Yes	Yes
C12: Delay Timers	Yes	Yes	No	No
C13: Inching Timers	Yes	Yes	Yes	Yes

Quick Stop™/Reverse Plug Simulation™

The **Quick Stop Function** provides an automatic Alternate Deceleration at Stop Command.

NOTE: The Quick Stop Deceleration time differs from the normal deceleration time and is applied only when the RUN command is removed.

Parmtr Code	Display	Function	Range	Initial Value	V/F Access	Open Loop Vector Access
C1-01	Quick Stop 0/1 0 Disabled 1 Enabled	Determines whether Quick Stop is enabled		0	Adv	Adv
C1-02	Quick Stop Time	Deceleration time during Quick Stop function.	0.0–25.5 sec	0	Adv	Adv

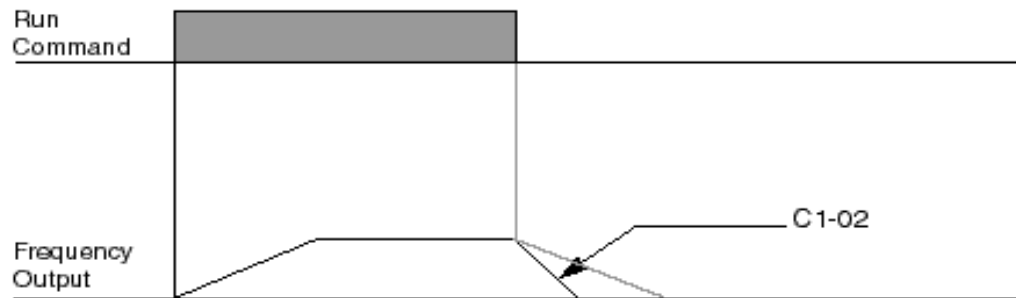

Figure 5-13: Quick Stop

The **Reverse Plug Simulation** provides an automatic alternate deceleration time/acceleration time at a change direction command. The deceleration time and the acceleration time are set independently of the normal acceleration and deceleration times.

Parmtr Code	Display	Function	Range	Initial Value	V/F Access	Open Loop Vector Access
C1-03	Reverse Plug 0/1	Determines whether Reverse Plug Simulation is enabled.		0	Adv	Adv
	0 Disabled					
	1 Enabled					
C1-04	RevPlg	Deceleration time during Reverse Plug Simulation.	0.0–25.5 sec	1.0	Adv	Adv
C1-05	RevPlg	Acceleration time during Reverse Plug Simulation	0.0–25.5 sec	1.0	Adv	Adv

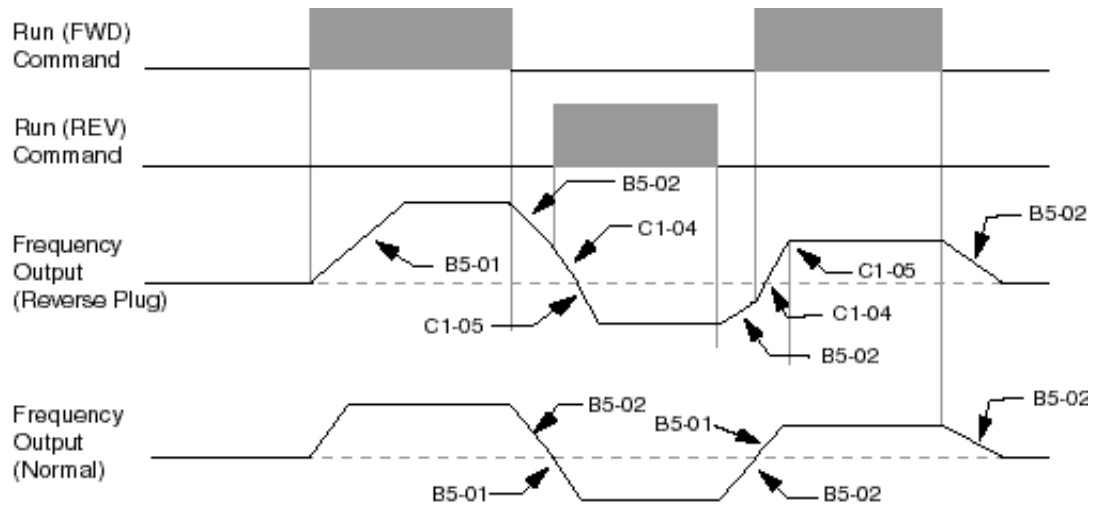

Figure 5-14: Reverse Plug Simulation

Micro-Positioning Control Gain

Micro-Positioning Control function can provide a reduced speed range operation for precise positioning. Enabled by a Multi-Function Input, it multiplies the normal speed reference by the Micro-Speed Gain. Two Micro-Speed Gains are available. Micro-Speed Gain 1 (C2-01) and Micro-Speed Gain 2 (C2-02). They can be adjusted and enabled independently. If both Micro-Speed 1 and Micro-Speed 2 are enabled, Micro-Speed 1 has higher priority over Micro-Speed 2.

Parltr Code	Display	Function	Range	Initial Value	V/F Access	Open Loop Vector Access
C2-01	MS Gain 1	For Micro-Positioning Control—the number multiplied by the Analog or Digital Speed Reference to achieve slow-speed operation.	0.00–1.00	1.00	Adv	Adv
C2-02	MS Gain 2	For Micro-Positioning Control—an alternate number multiplied by the Analog or Digital Speed Reference to achieve slow-speed operation.	0.00–1.00	1.00	Adv	Adv

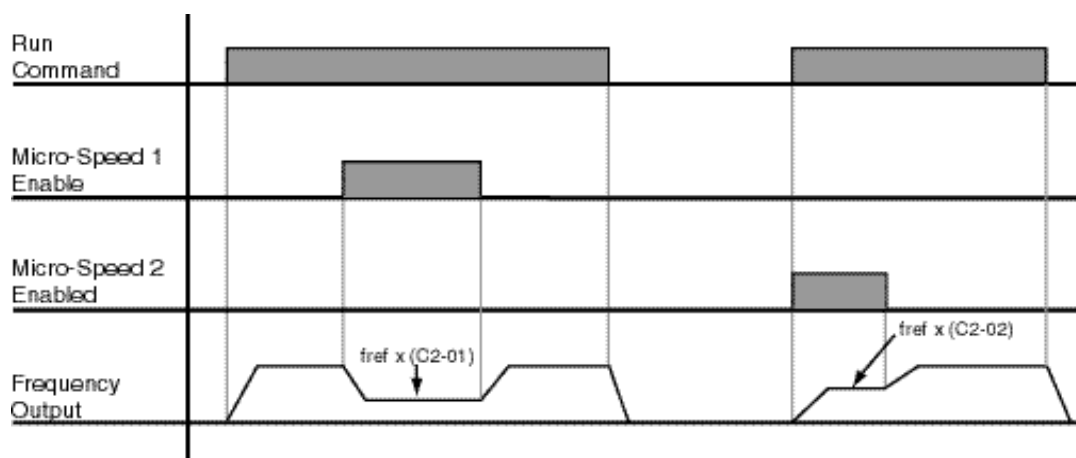

Figure 5-15: Micro-Positioning Control

End of Travel Limits

This function can automatically slow and stop a crane or hoist when it reaches its travel limits. Two types of limit inputs (slowdown and stop) are available in both travel directions. Inputs can be selected through either G5IF and G5IN4 cards.

Parmtr Code	Display	Function	Range	Initial Value	V/F Access	Open Loop Vector Access
C3-01	Up Limit 1 Speed	Speed at Upper Limit input.	0–150 Hz	6	Adv	Adv
C3-02	UL 1 Decel Time	Decel time to Upper Limit Speed.	0.0–25.5 sec	1.0	Adv	Adv
C3-03	UL 2 Stop Time	Decel time to STOP when Upper Limit is Input.	0.0–25.5 sec	0.5	Adv	Adv
C3-04	Low Limit 1 Speed	Speed at Lower Limit input.	0–150 Hz	6	Adv	Adv
C3-05	LL 1 Decel Time	Decel time to Lower Limit Speed.	0.0–25.5 sec	1.0	Adv	Adv
C3-06	LL 2 Stop Time	Decel time to STOP when Lower Limit is input.	0.0–25.5 sec	0.5	Adv	Adv
C3-07	*Upper Action	Determine the stop method at Upper Limit 2 and Lower Limit 2 Input.		0	Adv	Adv
	0	Decel to Stop				
	1	BB to Stop	Base Block			

* Initial value is determined by X-Press Programming tables 4-1 through 4-6.

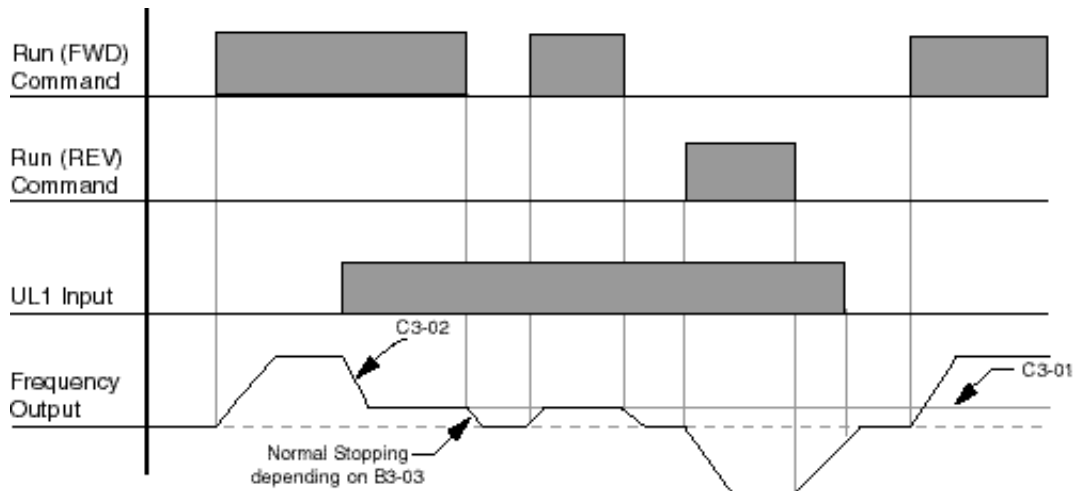

Figure 5-16: Upper Limit (UL1)

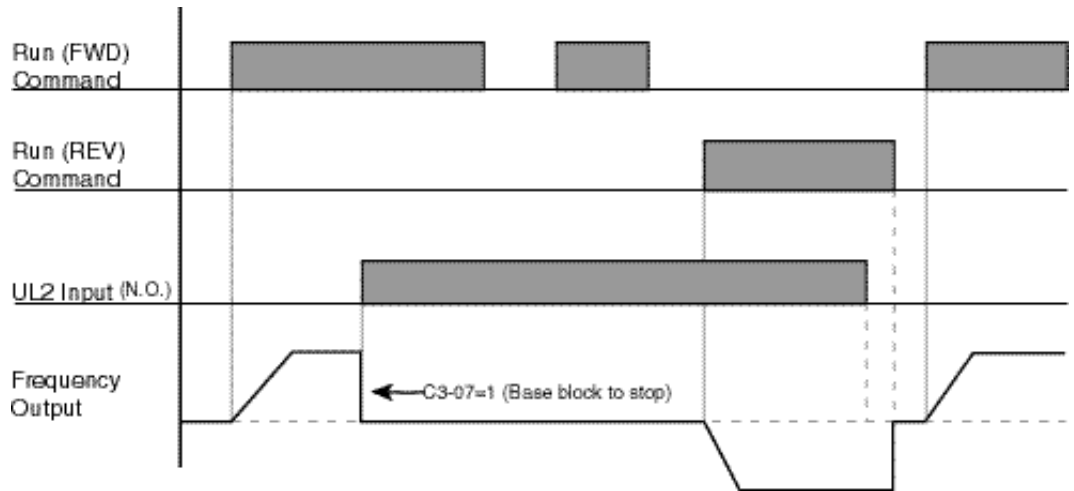

Figure 5-17: Upper Limit 2 (UL2)

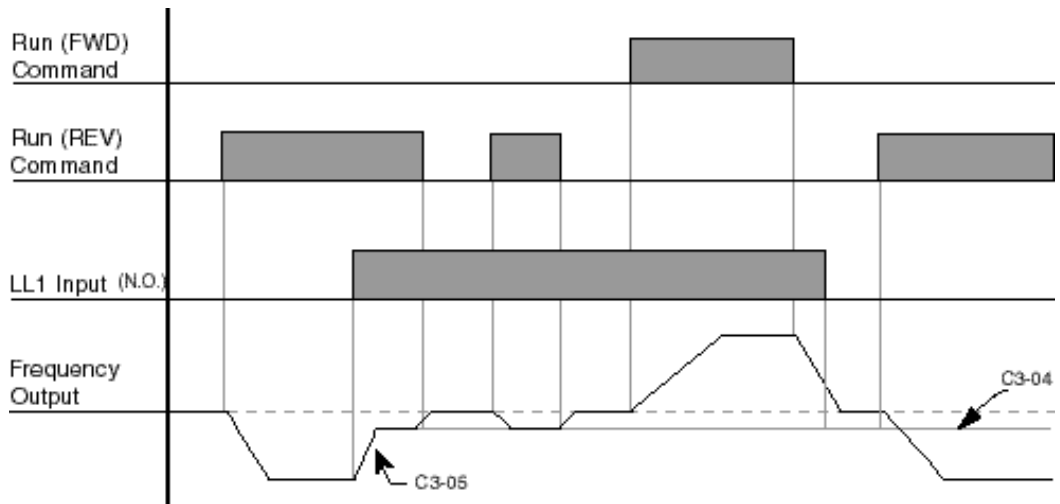

Figure 5-18: Lower Limit 1 (LL1)

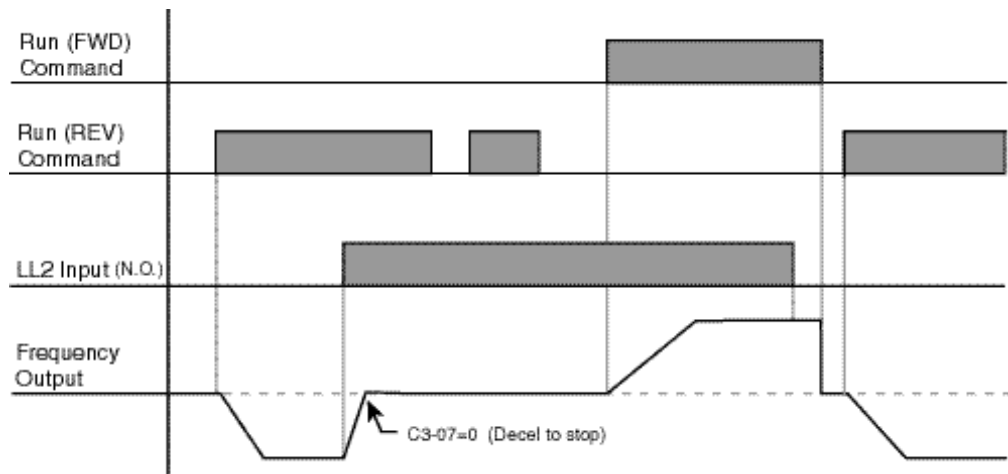

Figure 5-19: Lower Limit 2 (LL2)

Load Check™

Load Check function is a load-limiting feature that ensures the programmed load limit of the hoist is not exceeded. It prevents the lifting (and potential loss) of a load that is over rated capacity. When IMPULSE•G+ Series 2 detects an overload condition (Load Check Fault), it prevents any further raising. However, the load can be lowered at the speed that is specified by constant C5-14 (Load Check Fault speeds).

Parmtr Code	Display	Function	Range	Initial Value	V/F Access	Open Loop Vector Access
C5-01	Load Check 0/1 <i>0 Disabled</i> <i>1 Enabled</i>	Determines whether Load Check is enabled.		0	Adv	Adv
C5-02	LC Alarm Action <i>0 Alarm Only</i> <i>1 Decel to Stop</i> <i>2 Coast to Stop</i> <i>3 Fault Stop</i>	Action at Load Check alarm or fault. "BB to Stop" is Immediate Stop at STOP.		2	Adv	Adv
C5-04	Look Speed 1	First Load Check frequency reference.	0–150 Hz	6	Adv	Adv
C5-05	1 Ref for LS 1	Load Check 1 Current reference for Look Speed 1 when Output Frequency ≤ Look Speed 1.	30–200% IRC	160	Adv	–
C5-06	Vec Torque Ref	Torque reference at LS1, 2, 3	0–300%	125	–	Adv
C5-07	Look Speed 2	Second Load Check frequency reference	0–150 Hz	20	Adv	Adv
C5-08	1 Ref for LS 2	Load Check 2 Current reference for Look Speed 2 when Look Speed 1 ≤ Frequency Output ≤ Look Speed 2	30–200% IRC	160	Adv	–
C5-09	Look Speed 3	Third Load Check frequency reference	0–150 Hz	60	Adv	Adv
C5-10	1 Ref for LS 3	Load Check 3 Current Reference when Look Speed 1 < Frequency Output ≤ Look Speed 3	30–200% IRC	160	Adv	–
C5-11	1 Ref for > LS 3	Load Check Current when Output Frequency > Look Speed 3	30–200% IRC	160	Adv	Adv
C5-12	LC Setting Time	Time for holding Output Frequency to stabilize Output Current	0–2.55 sec	0.20	Adv	Adv
C5-13	LC Test Time	Time (after the LC Setting Time) for comparing Output Current with Reference Current	0–2.55 sec	0.10	Adv	Adv
C5-14	LC Fault Speed	Maximum lowering speed after Load Check fault	0–150 Hz	6	Adv	Adv

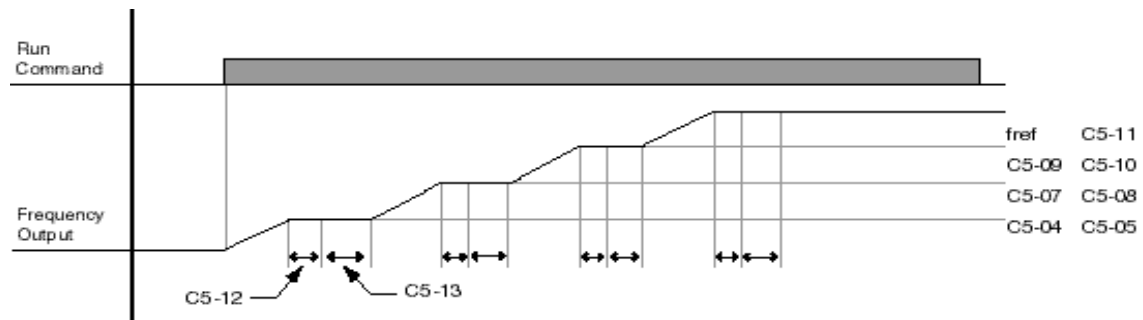

Figure 5-20: Load Check

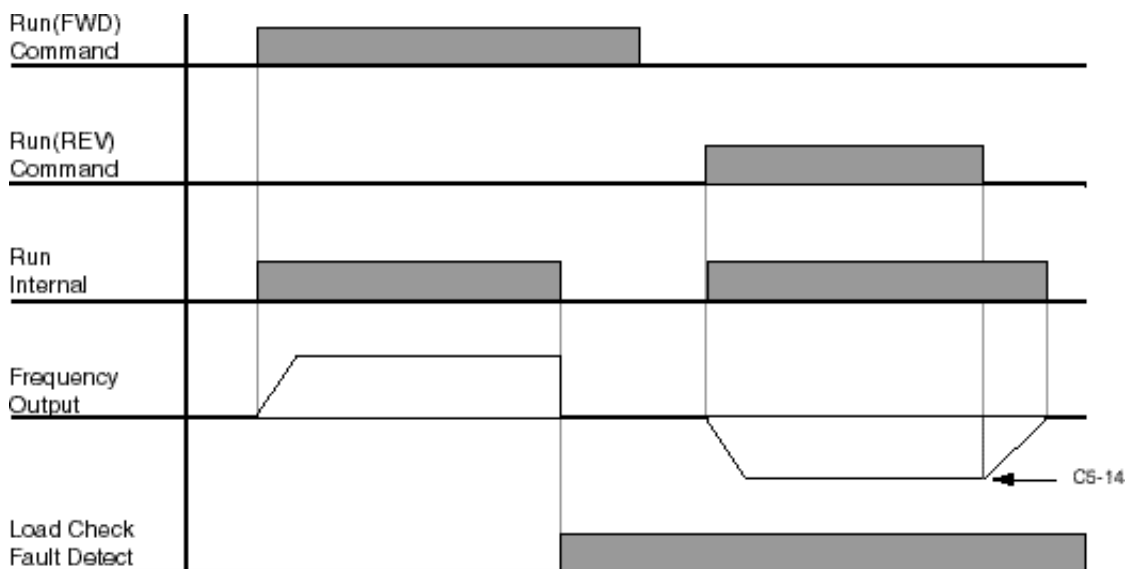

Figure 5-21: Example of Operation C5-02=2

Swift Lift™

Swift Lift provides additional productivity by allowing a hoist to be moved into position quickly. The feature enables the motor to over speed when the load is less than 100 percent of the rated capacity. Swift Lift determines the torque required for the load, calculates the maximum safe speed, and automatically accelerates to this speed. Swift Lift accelerates to maximum safe speed (C6-02) when the motor torque is below a programmed value (C6-04).

*NOTE: Swift Lift is disabled when in traverse applications or in the reverse direction.
Maximum Frequency (E1-04) must be \geq C6-02 and C6-03.*

Parmtr Code	Display	Function	Range	Initial Value	V/F Access	Open Loop Vector Access
C6-01	Swift Lift 0/1 0 Disabled 1 Enabled Automatic 2 Enabled by MFI	Determines whether Swift Lift is enabled.		0	Adv	Adv
C6-02	Swift Lift ForSpd	Maximum Output Frequency during Swift Lift—FORWARD.	0–150 Hz	60	Adv	Adv
C6-03	Swift Lift RevSpd	Maximum Output Frequency during Swift Lift—REVERSE.	0–150 Hz	60	Adv	Adv
C6-04	Swift Lift For T	Maximum output torque below which Swift Lift—FORWARD is enabled.	0–100%	50	Adv	Adv
C6-05	Swift Lift Rev T	Maximum output torque below which enabled Swift Lift REVERSE.	0–255%	30	Adv	Adv
C6-06	SL Enabling Spd	Threshold frequency at which Swift Lift is enabled.	0–150 Hz	60	Adv	Adv
C6-07	SL Delay Time	Delay time at enabling speed prior to torque-compare function.	0.0–30.0 sec	2.0	Adv	Adv
C6-08	SFS Acc Gain	Speed feedback acceleration multiplier.	0.1–9.9	1.0	Adv	Adv

Enable Swift Lift Function:

2,3,5-Speed Multi-Step (A1-04=0, 5, or 6):

1. Set C6-01=1 or 2 to enable the **Swift Lift Function**, 1= Enable Automatic, 2= Enable by Multi-Function Input (MFI).
2. Set C6-02 and C6-03 to determine **Swift Lift** maximum FOR/REV output frequency.
3. Set C6-04 and C5-05 to determine **Swift Lift** maximum enable output current.
4. Set the **Swift Lift Enabling Speed (C6-06)** one or two hertz below the maximum normal running speed reference.

For example: If the maximum normal running speed is at 60 Hz, set C6-06 to 59 Hz or 58 Hz as the **Swift Lift Enabling Speed**.

5. Ensure that the **Maximum Frequency (E1-04)** is increased from 60 Hz.

2, 3 Step Infinite Variable (A1-04=1 or 2)

6. If the system is using **2-Step** or **3-Step Infinite Variable** as the **Speed Control Method**, additions to the steps from 1 to 5, the following formula is used to adjust the constant **B2-1 (Reference Upper Limit)**.

$$B2-01=60 \text{ Hz} \times 100 / E1-04$$

Bi-Polar/Uni-Polar Analog (A1-04=3 or 4)

7. If the system is using **Bi-Polar Analog** or **Uni-Polar Analog** as the **Speed Control Method**, additions to the steps from 1 to 5, the following formula is used to adjust the constant **H3-02 (Gain Multiplier for Terminal 13 analog input signal)**, **H3-10 (Gain Multiplier for Terminal 14 analog input signal)**.

$$H3-02=60 \text{ Hz} \times 100 / E1-04 \text{ or } H3-10=60\text{Hz} \times 100/E1-04$$



WARNING

Motors and drive machinery must be capable of operating above motor base speed. Consult the motor/gearbox/hoist manufacturer before enabling Swift Lift function. Failure to observe this warning may result in damage to equipment and possible injury or death to personnel.

Torque Limit (Open Loop Vector)

If the Open Loop Vector control mode is selected, the IMPULSE•G+ Series 2 can dynamically control the torque output of the motor at all times. The Torque Limit Function limits the amount of motor torque on all four quadrants of vector control operation:

- Forward Motoring
- Reverse Motoring
- Forward Regenerating
- Reverse Regenerating

When the Torque Limits are reached during operation, the programmed acceleration and deceleration times become second priority.

Parmr Code	Display	Function	Range	Initial Value	V/F Access	Open Loop Vector Access
C7-01	Torque Limit Fwd	FORWARD torque limit	0-300%	150	-	Adv
C7-02	Torque Limit Rev	REVERSE torque limit	0-300%	150	-	Adv
C7-03	Torq Lmt Rgn	Regenerative torque limit at FORWARD	0-300%	180	-	Adv
C7-04	Torq Limit Rev Rgn	Regenerative torque limit at REVERSE	0-300%	180	-	Adv
C7-07	T-Lim Gain MFI	Used when H1-01~H1-06= 15 and MFI is on	0-2.55	1.25	-	Adv

Brake Answer Back

The following timers are used when multi-function inputs (H1-01~06) are set for (36) brake answer back.

Parmr Code	Display	Function	Range	Initial Value	V/F Access	Open Loop Vector Access
C8-04	Roll Back Timer	BE4 Delay timer for brake to OPEN	0-2.55 sec	0.7 sec	Adv	Adv
C8-11	Brake Delay Time	BE5 Delay timer for brake to CLOSE	0-25.5 sec	0.7 sec	Adv	Adv
C8-17	BE6 Up Speed	Maximum up speed after Be6 is detected	0-150.00 Hz	6.00	Adv	Adv

G5IN4 Digital Multi-Function Inputs

The optional G5IN4 board accepts four additional multi-function inputs. The G5IN4 board has four terminals, each of which can be programmed to one of the fourteen sets of inputs. Each input in the set can be enabled or disabled.

1. Set C9-01 to 1,
2. Determine the parameter C9-02 setting by specifying the first digit (from left) and the fourth digit (from left) using table 5.2 and 5.3. The second and third digit should always be "0".
3. Set parameter C9-02.

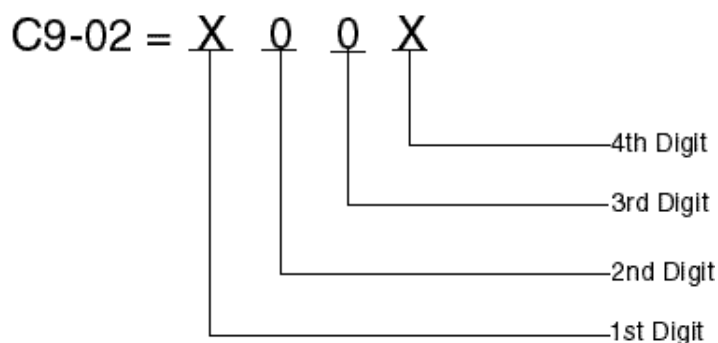

1 = 120V is present on terminal

0 = No voltage is present on terminal

MONITOR	TERMINAL			
	1	2	3	4
U1-25	1	2	3	4
1	1	0	0	0
2	0	1	0	0
3	1	1	0	0
4	0	0	1	0
5	1	0	1	0
6	0	1	1	0
7	1	1	1	0
8	0	0	0	1
9	1	0	0	1
A	0	1	0	1
B	1	1	0	1
C	0	0	1	1
D	1	0	1	1
E	0	1	1	1
F	1	1	1	1

Table 5.2: G5IN4 Digital Multi-Function Input Sets (1 through E) (Software 14906, 14908, 14909)

First Digit (From Left) You Enter	Multi-Function Input Assigned to Each Terminal			
	Terminal 1	Terminal 2	Terminal 3	Terminal 4
1	<i>Upper Limit—SLOW DOWN; Normally Closed</i>	<i>Upper Limit STOP; Normally Closed</i>	<i>Lower Limit SLOW; Normally Closed</i>	<i>Lower Limit STOP; Normally Closed</i>
2	<i>Upper Limit—SLOW DOWN; Normally Open</i>	<i>Upper Limit STOP; Normally Open</i>	<i>Lower Limit SLOW; Normally Open</i>	<i>Lower Limit STOP; Normally Open</i>
3	<i>Upper Limit STOP; Normally Closed</i>	<i>Lower Limit STOP; Normally Closed</i>	<i>Micro-Positioning Control Multiplier 1</i>	<i>Micro-Positioning Control Multiplier 2</i>
4	<i>Upper Limit STOP; Normally Open</i>	<i>Lower Limit STOP; Normally Open</i>	<i>Micro-Positioning Control Multiplier 1</i>	<i>Micro-Positioning Control Multiplier 2</i>
5	<i>Upper Limit STOP; Normally Closed</i>	<i>Lower Limit STOP; Normally Closed</i>	<i>Micro-Positioning Control Multiplier 1</i>	<i>Swift-Lift Enable</i>
6	<i>Upper Limit STOP; Normally Open</i>	<i>Lower Limit STOP; Normally Open</i>	<i>Micro-Positioning Control Multiplier 1</i>	<i>Swift-Lift Enable</i>
7	<i>Upper Limit STOP; Normally Closed</i>	<i>Lower Limit STOP; Normally Closed</i>	<i>Micro-Positioning Control Multiplier 1</i>	<i>Torque Limit Acceleration/ Deceleration</i>
8	<i>Upper Limit STOP; Normally Closed</i>	<i>Lower Limit STOP; Normally Closed</i>	<i>Micro-Positioning Control Multiplier 1</i>	<i>Alternate Acceleration/ Deceleration Time Changeover</i>
9	<i>Upper Limit STOP; Normally Closed</i>	<i>Lower Limit STOP; Normally Closed</i>	<i>Micro-Positioning Control Multiplier 1</i>	<i>Zero Servo Command</i>
A	<i>Upper Limit STOP; Normally Closed</i>	<i>Lower Limit STOP; Normally Closed</i>	<i>Micro-Positioning Control Multiplier 1</i>	<i>Weight Measurement Command</i>
B	<i>Swift-Lift Enable</i>	<i>Torque Limit Acceleration/ Deceleration</i>	<i>Micro-Positioning Control Multiplier 1</i>	<i>Micro-Positioning Control Multiplier 2</i>
C	<i>Alternate Torque Limit</i>	<i>Alternate Acceleration/ Deceleration Time</i>	<i>Micro-Positioning Control Multiplier 1</i>	<i>Upper Limit SLOW; Normally Closed</i>
D	<i>Zero Servo Command</i>	<i>Torque Limit Acceleration/ Decel</i>	<i>Micro-Positioning Control Multiplier 1</i>	<i>Micro-Positioning Control Multiplier 2</i>
E	<i>Alternate Speed Reference Upper Limit</i>	<i>Serial/Inverter Command Changeover</i>	<i>Micro-Positioning Control Multiplier 1</i>	<i>Alternate Torque Limit</i>

Table 5.3: G5IN4 Digital Multi-Function Input Sets (0 through F) (Software 14910, 14911)

First Digit (From Left) You Enter	Multi-Function Input Assigned to Each Terminal			
	Terminal 1	Terminal 2	Terminal 3	Terminal 4
0	No function	No function	No function	No function
1	Upper Limit–SLOW DOWN; Normally Closed	Upper Limit–STOP; Normally Closed	Lower Limit–SLOW DOWN; Normally Closed	Lower Limit–STOP; Normally Closed
2	Upper Limit–SLOW DOWN; Normally Open	Upper Limit–STOP; Normally Open	Lower Limit–SLOW DOWN; Normally Open	Lower Limit–STOP; Normally Open
3*	Multi-Step Speed 2	Multi-Step Speed 3	Multi-Step Speed 4	Multi-Step Speed 5
4*	Hold function (2nd step of Three-Step Infinitely Variable).	Acceleration function (2nd step of Two-Step Infinitely Variable or 3rd step of Three-Step Infinitely Variable).	Micro-Positioning Control Multiplier 1	Upper Limit–STOP; Normally Closed
5	Upper Limit–STOP Normally Closed	Upper Limit–SLOW DOWN; Normally Closed	Lower Limit–STOP; Normally Closed	Lower Limit–SLOW DOWN; Normally Closed
6	Upper Limit–STOP; Normally Open	Upper Limit–SLOW DOWN; Normally Open	Lower Limit–STOP; Normally Open	Lower Limit–SLOW DOWN; Normally Open
7*	Multi-Step Speed 5	Multi-Step Speed 4	Multi-Step Speed 3	Multi-Step Speed 2
8*	Upper Limit–STOP; Normally Closed	Micro-Positioning Control Multiplier 1	Acceleration function (2nd step of Two-Step Infinitely Variable or 3rd step of Three-Step Infinitely Variable).	Hold function (2nd step of Three-Step Infinitely Variable).
9	Upper Limit–STOP; Normally Closed	Lower Limit–STOP; Normally Closed	Micro-Positioning Control Multiplier 1	No function
A	Upper Limit–STOP; Normally Closed	Lower Limit–STOP; Normally Closed	Micro-Positioning Control Multiplier 1	No function
B	Swift-Lift Enable	Torque Limit Acceleration/Deceleration	Micro-Positioning Control Multiplier 1	Micro-Positioning Control Multiplier 2
C	Alternate Torque Limit Multiplier	Acceleration and Deceleration Changeover Time	Micro-Positioning Control Multiplier 1	Upper Limit–SLOW DOWN; Normally Closed
D	No function	Torque Limit Acceleration/Deceleration	Micro-Positioning Control Multiplier 1	Micro-Positioning Control Multiplier 2
E	Alternate Upper Limit Frequency Reference	Serial/Inverter Run and Speed Reference Changeover	Micro-Positioning Control Multiplier 1	Alternate Torque Limit Multiplier
F	No function	No function	No function	No function

* IF using the G5IN4 to input speed references, A1-04 should be set for data 7 (not used). This will help to avoid an OPE03 fault caused by having more than one terminal programmed with the same data.

Table 5.4: Enabling/Disabling Decision Table for C9-02

Input for Terminal 1	Input for Terminal 2	Input for Terminal 3	Input for Terminal 4	Fourth Digit (From Left) You Enter
<i>E</i>	D	D	D	1
D	<i>E</i>	D	D	2
<i>E</i>	<i>E</i>	D	D	3
D	D	<i>E</i>	D	4
<i>E</i>	D	<i>E</i>	D	5
D	<i>E</i>	<i>E</i>	D	6
<i>E</i>	<i>E</i>	<i>E</i>	D	7
D	D	D	<i>E</i>	8
<i>E</i>	D	D	<i>E</i>	9
D	<i>E</i>	D	<i>E</i>	A
<i>E</i>	<i>E</i>	D	<i>E</i>	B
D	D	<i>E</i>	<i>E</i>	C
<i>E</i>	D	<i>E</i>	<i>E</i>	D
D	<i>E</i>	<i>E</i>	<i>E</i>	E
<i>E</i>	<i>E</i>	<i>E</i>	<i>E</i>	F

Key: E=Enable
D=Disable

*For example, you want to use three inputs. They are Upper Limit Stop Normally Closed Proximity Sensor, Micro-Positioning Control Multiplier 1 Input, and Swift Lift Enable Input. Follow the steps below:

1. Set C9-01 to 1 (enable G5IN4 card).
2. Determine the first digit of C9-02 using Table 5.2 or 5.3. Five is the choice because row five contains all three inputs you want.
3. Determine the last digit (fourth digit from left) using table 5.4. D is the choice because row D enables all three inputs. Terminal 2 on row D is disabled (Lower Limit Stop Normally Closed).
4. Set parameter.

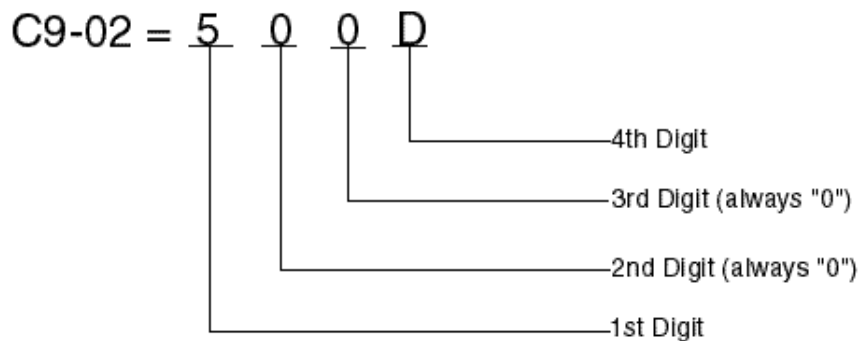

* Example uses data from table 5.2.

Delay Timers

This function is used in trolley or bridge applications. It can reduce the mechanical brake wear when the operator tries to position a load. This function is available only in traverse mode and the constant B3-03 must be set to 4 (Ramp With Timer).

Parmtr Code	Display	Function	Range	Initial Value	V/F Access	Open Loop Vector Access
C12-01	Brake Jog Delay	Brake set delay time at Jog Control input.	0.0–100.0 sec	0.0 sec	Adv	Adv
C12-02	Brake Run Delay	Brake set delay time at RUN input.	0.0–100.0 sec	0.0 sec	Adv	Adv

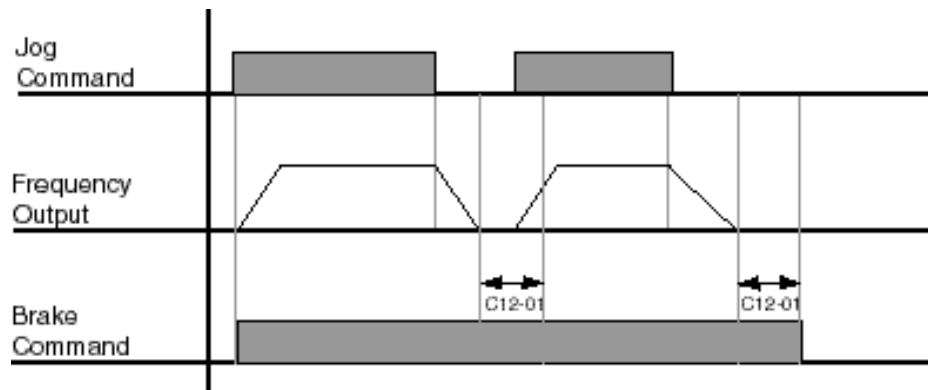

Figure 5-22: Brake Delay Timers

NOTE: The Jog control input is a multi-function input. It is enabled by programming data 16 or 17 in H1-01~06.

Inching Control

Inching Control Function can be enabled by programming data 18, 19, and 1A respectively to the Multi-Function input terminals (H1-01~06).



CAUTION

A directional input is not needed on terminals 1 or 2.

Parltr Code	Display	Function	Range	Initial Value	V/F Access	Open Loop Vector Access
C13-01	Inch Run Time	Inching Control run time.	0.00–2.55 sec	1.00	Adv	Adv
C13-02	Repeat Delay T	Inching Control repeat delay time.	0.00–2.55 sec	1.00	–	Adv
H1-01~06	Terminal x Sel				Adv	Adv
	18 Inching Forward Command					
	19 Inching Reverse Command					
	1A Inching Repeat Command					

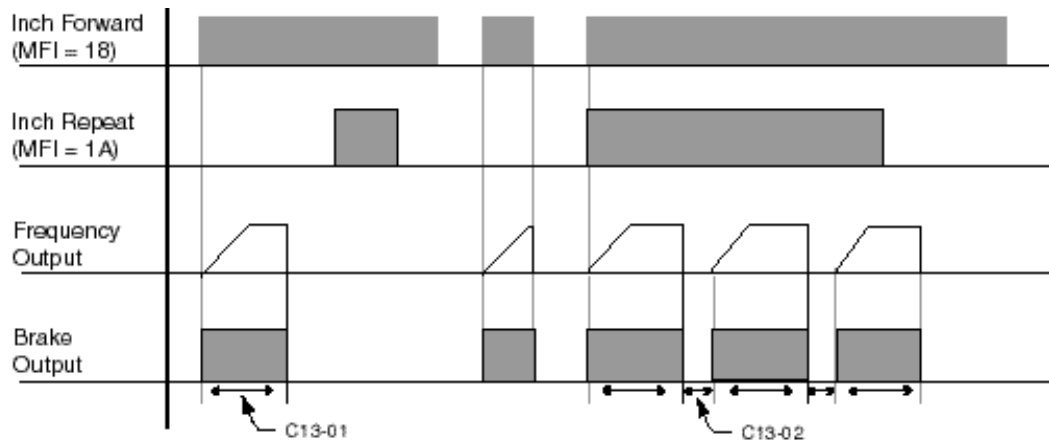

Figure 5-23: Inching Function and Inching Repeat

Tuning

- D1 DC Injection
- D2 Automatic Slip Compensation
- D3 Torque Compensation
- D6 Droop Control
- D8 Dwell Function
- D9 S-Curve Acceleration/Deceleration
- D10 Carrier Frequency
- D11 Hunt Prevention
- D12 Factory Tuning

DC Injection

DC Injection Braking can be used to stop a motor when its rotational direction is uncertain prior to running.

With ramp to stop enabled (B3-03=0), the IMPULSE•G+ Series 2 controls motor deceleration according to the Decel Time setting at stop. Then, the DC Injection current is applied to the motor when DC Injection starting frequency is reached (D1-01). The effective DC Injection time and current should be set to provide adequate stopping without excessive motor heating. The DC Injection voltage is determined by the DC Injection braking current and motor impedance.

The multi-function input terminals can also be utilized to control DC Injection. When used, DC Injection current will be applied until the input is removed.

Parmtr Code	Display	Function	Range	Initial Value	V/F Access	Open Loop Vector Access
D1-01	DCInj Start Freq	DC Injection braking frequency start.	0.0–10 Hz	1.5	Adv	Adv
D1-02	DCInj Current	DC Injection Current.	0–100%	50	Adv	Adv
D1-03	DCInj@Start	DC Injection braking time.	0.00–10.00 sec	0.0 (Standard Hoist) 0.20(OLV)	Adv	Adv
D1-04	DCInj Time@Stop	DC Injection braking time at stop.	0.00–10.00 sec	0.05	Adv	Adv
D1-05	DC Injection P Gain		0.00–1.00	0.05	Adv	Adv
D1-06	DC Injection Integral Time		0–1000 msec	100	Adv	Adv
D1-07	DC Injection Limit		0.0–30%	15.0	Adv	Adv

NOTE: When using DC inject to stop as described on page 5-9, the amount of DC inject time will change with the output frequency. When D1-01 is set to a lower value than the minimum output frequency (E1-09), DC injection will start at the E1-09 setting. D1-02 is set as a percentage of inverter rated current.

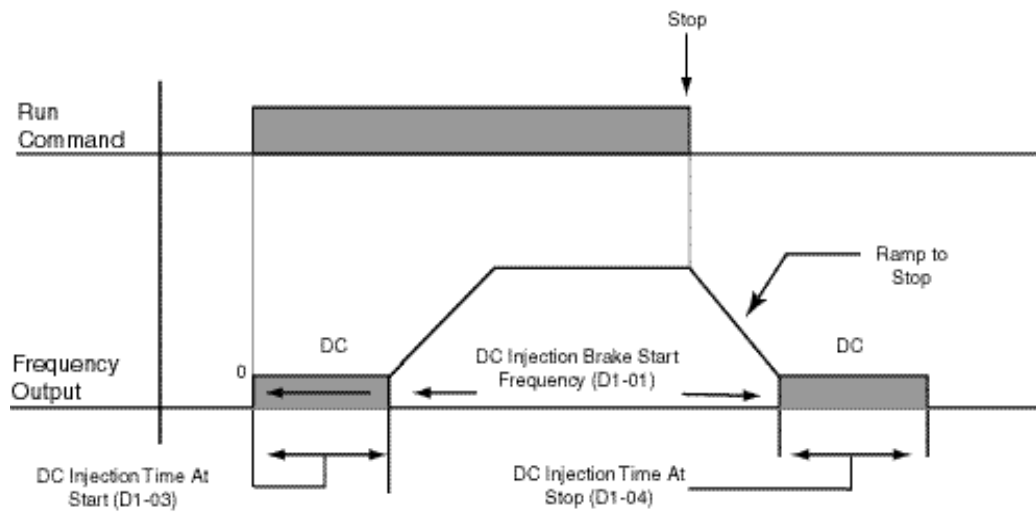

Figure 5-24: DC Injection Braking Sequence (B3-03=0)

Automatic Slip Compensation

As the load becomes larger, the motor speed is reduced and the motor slip increases. The slip compensation function keeps the motor speed constant under varying load conditions. D2-01 sets the slip compensation gain. When the gain is “1.0”, the output frequency is increased by 1% of the E1-06 setting at rated current. A setting of “0.0” results in no slip compensation. D2-02 and D2-03 affect this gain as shown below in Figure 5-25.

Parltr Code	Display	Function	Range	Initial Value	V/F Access	Open Loop Vector Access
D2-01	Slip Comp Gain	Slip compensation multiplier.	0.0–2.5	1.0 (OLV) 0 (V/f)	Adv	Adv
D2-02	Slip Comp Time	Slip compensation primary delay time.	0–10000 msec	200 (OLV) 2000 (V/f)	Adv	Adv
D2-03	Slip Comp Limit	Slip compensation limit.	0–250%	200	Adv	Adv
D2-04	Slip Comp Regen	Slip compensation during regeneration.		0	Adv	Adv
		0 Disabled 1 Enabled				
D2-05	Slip Comp V/F	Slip Compensation at V/F setting.		0	–	Adv
		0 Include 1 Exclude				

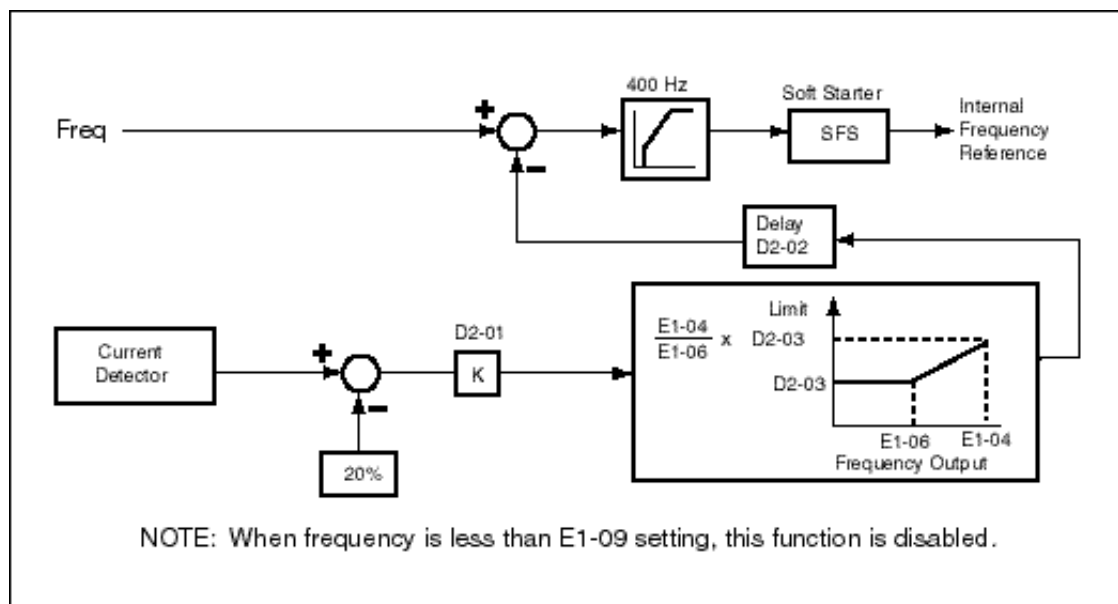

Figure 5-25: Slip Compensation Block Diagram

Example

If the desired frequency is 45 Hz then the Motor slip is 1.5% at full load. The Slip Comp Gain D2-01 is set to 1.5%. The actual output frequency at full load is equal to 45.67 Hz.

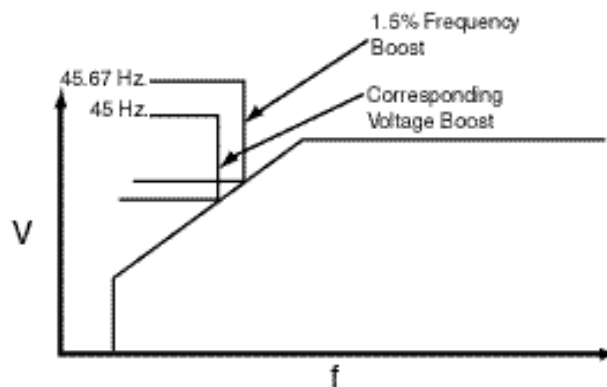

Figure 5-26: Example of Automatic Slip Compensation

Torque Compensation

The motor torque requirement changes according to load conditions. Full-range automatic torque boost adjusts the voltage of the V/f pattern according to the required torque. The IMPULSE•G+ Series 2 automatically adjusts the voltage during constant-speed operation as well as during acceleration. See below, Figure 5-27.

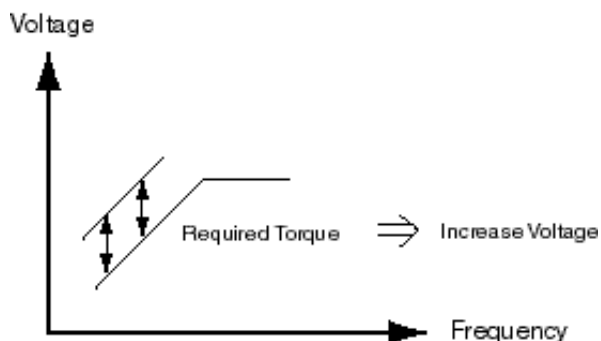

Figure 5-27: Torque Characteristics

The required torque is calculated by the inverter. This ensures tripless operation and power savings.

Output voltage \propto Torque compensation gain x Required torque

Normally, no adjustment is necessary for torque compensation gain. When more torque is needed, increase the torque compensation gain in one tenth (0.1) increments. When the wiring distance between the inverter and the motor is 100ft. or longer increase the setting. If or when the motor generates excessive vibration or oscillates, decrease the torque compensation.

Increasing torque compensation gain increases motor torque, but an excessive increase may cause the following:

- Inverter fault trips due to motor overexcitation and/or
- Motor overheat or excessive vibration

Increase the torque compensation time constant in 10ms increments when the motor's output current is unstable. Decrease this value when speed response is slow.

Parltr Code	Display	Function	Range	Initial Value	V/F Access	Open Loop Vector Access
D3-01	Torq Comp Gain	Torque compensation multiplier.	0.00–2.50	1.00	Adv	Adv
D3-02	Torq Comp Time	Torque compensation time.	0.00– 10000 msec	20 (OLV) 200 (V/f)	Adv	Adv

Droop Control

The Droop Control function reduces the motor speed based on the load torque of the motor. The actual amount of motor speed reduction is based on the ratio of the amount of motor torque and maximum output frequency (E1-04).

The Droop Delay time D6-02 sets the response time for the Droop Control function. Decreasing the Droop Delay time will cause the response to become quicker; however, instability may occur.

Parmtr Code	Display	Function	Range	Initial Value	V/F Access	Open Loop Vector Access
D6-01	Droop Quantity	Sets the motor speed reduction when Torq Output = 100%.	0.0–100.0	0.0	–	Adv
D6-02	Droop Delay Time	Sets the response for the drooping function.	0.03–2.0 sec	0.05	–	Adv

Dwell Function

The Dwell function is used to temporarily hold the output frequency at a set reference for a set time. This function can be used when driving a motor with a heavy starting load. The pause in acceleration reduces traditionally high starting current.

Parmtr Code	Display	Function	Range	Initial Value	V/F Access	Open Loop Vector Access
D8-01	Dwell Ref @ Start	Sets Dwell frequency reference at start.	0.0–150.0 Hz	0	Adv	Adv
D8-02	Dwell Time @ Start	Sets the time duration for the Dwell function at start.	0.0–10.0 sec	0	Adv	Adv
D8-03	Dwell Ref @ Stop	Sets dwell frequency Reference at stop.	0.0–150.0 Hz	0	Adv	Adv
D8-04	Dwell Time @ Stop	Sets the time duration for the Dwell function at stop.	0.0–10.0 sec	0	Adv	Adv

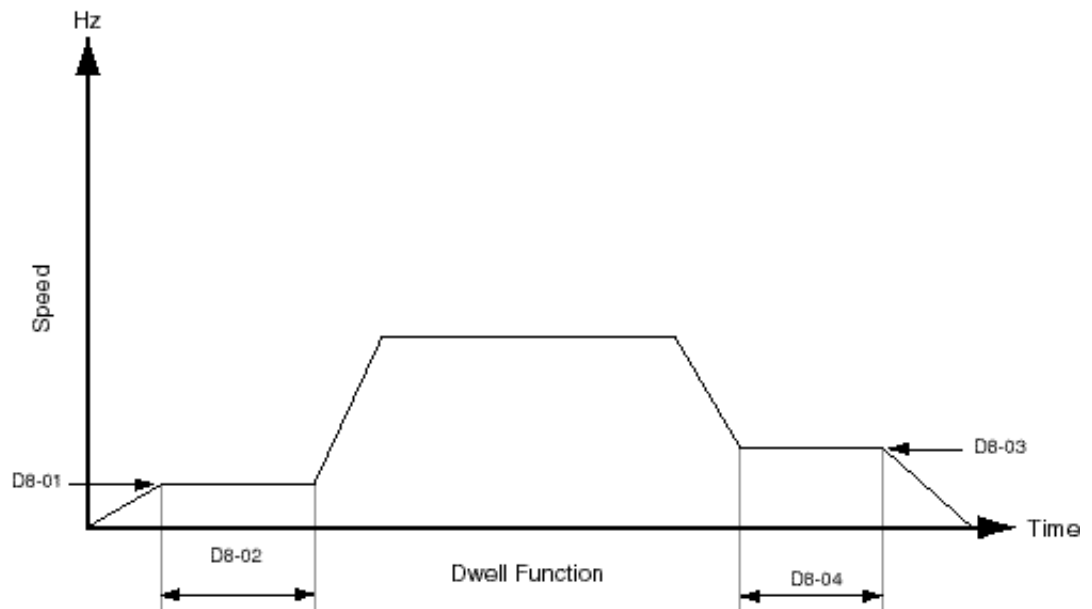

Figure 5-28: Dwell Function

S-Curve Acceleration/Deceleration

A S-Curve pattern is used to reduce shock and provide smooth transitions during machine acceleration and deceleration. S-Curve Characteristic time is the time from the output frequency to the set accel/decel time. See Figures 5-29 and 5-30.

Parmtr Code	Display	Function	Range	Initial Value	V/F Access	Open Loop Vector Access
D9-01*	S-Crv Acc @ Start	Sets S-Curve time at Accel start	0.00–2.50 sec	1.50	Adv	Adv
D9-02*	S-Crv Acc @ End	Sets S-Curve time at Accel end	0.00–2.50 sec	1.50	Adv	Adv
D9-03*	S-Crv Dec @ Start	Sets S-Curve time Decel start	0.00–2.50 sec	1.50	Adv	Adv
D9-04	S-Crv Dec @ End	Sets S-Curve time at Decel end	0.00–2.50 sec	0	Adv	Adv

* Initial value is determined by X-Press Programming tables 4-1 through 4-6.

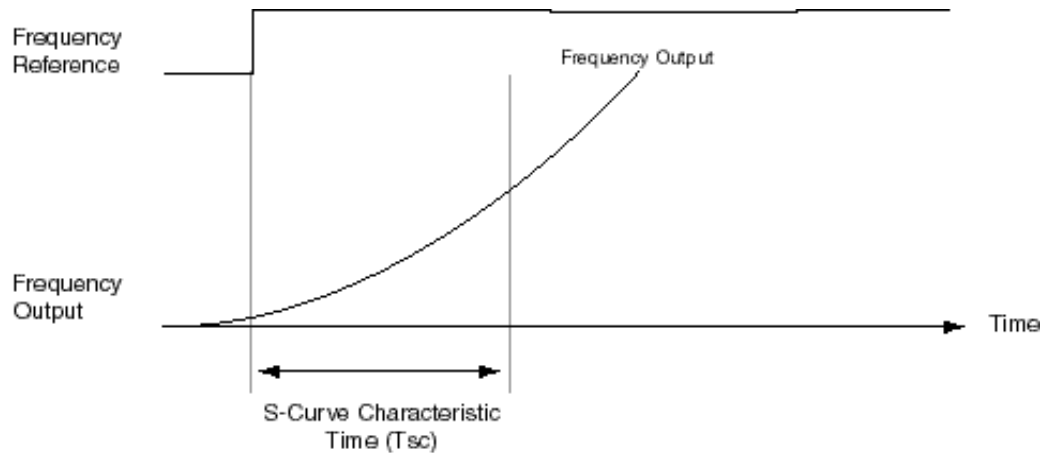

Figure 5-29: S-Curve Characteristic Timing Diagram (at start)

The figure below shows FWD/REV run switching during deceleration to stop. The S-curve function will add time to the acceleration and deceleration. Time to accelerate from the minimum frequency to the maximum frequency (total acceleration) = $B5-01 + (D9-01 + D9-02)/2$.



CAUTION

CAUTION Accel/decel times will be extended.

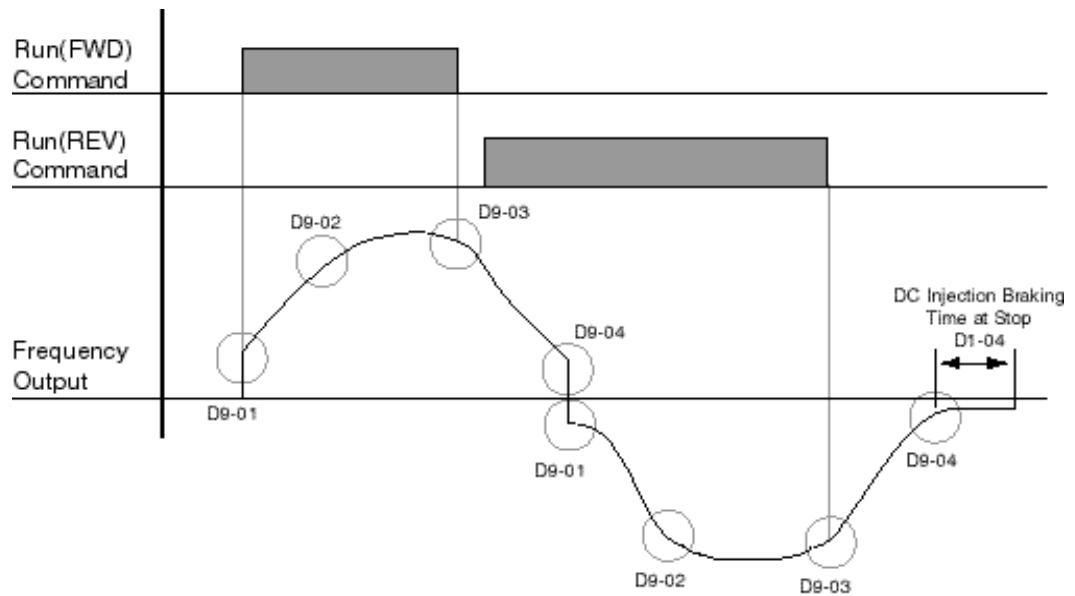

Figure 5-30: S-Curve Characteristics–FWD/REV Operation

Carrier Frequency

This function sets the inverter output transistor switching frequency (Carrier Frequency). Increasing the carrier frequency reduces motor noise. See Figure 5-31 on the next page.

When the control method is open loop vector, the range of D10-01 is 2.0 to 10.0 kHz, and parameters D10-02 and D10-03 are not used.

Parmtr Code	Display	Function	Range	Initial Value	V/F Access	Open Loop Vector Access
D10-01	Carrier Frequency Max	Carrier frequency upper limit.		3	Adv	Adv
	0 0.4 kHz					
	1 1.0 kHz					
	2 1.5 kHz					
	3 2.0 kHz					
	4 2.5 kHz					
	5 5.0 kHz					
	6 10.0 kHz					
D10-02	Carrier Frequency Min	Carrier frequency lower limit.		3	Adv	–
	0 0.4 kHz					
	1 1.0 kHz					
	2 1.5 kHz					
	3 2.0 kHz					
	4 2.5 kHz					
	5 5.0 kHz					
	6 10.0 kHz					
D10-03	Carrier Freq Gain	Carrier frequency proportional multiplier.	00–99	0	Adv	–

Hunt Prevention

Occasionally, in an application, resonance between the internal control system and the mechanical system causes current instability. This is called hunting, and may cause a crane to vibrate at a lower speed (up to 30 Hz) and light load. The hunting prevention function monitors the motor flux and uses a special control circuit to “smooth out” any peaks in the output current wave form.

Increase the set value of D11-02 when hunting is present while driving a light load. Decrease the set value of D11-02 when the motor vibrates or stalls while driving a heavy load.

Parmtr Code	Display	Function	Range	Initial Value	V/F Access	Open Loop Vector Access
D11-01	Hunt Prevention Select	Enable/Disable Hunt Prevention function		1	Adv	–
	<i>0 Disable</i>					
	<i>1 Enable</i>					
D11-02	Hunt Prevention Gain	Hunting Prevention Gain	0.00–2.50	1.00	Adv	–

Factory Tuning

Some adjustment may be required when hunting conditions are present during Open Loop Vector control. Decrease the set value of D12-08 when hunting occurs. Increase the set value of D12-08 when the speed or torque response is slow.

During normal auto-tuning, the inverter is tuned while running at a carrier frequency of 2kHz. This parameter allows the user to specify the inverter's carrier frequency during auto-tuning. Adjustment may be necessary if "OC" fault is displayed after completion of auto-tuning.

Parmtr Code	Display	Function	Range	Initial Value	V/F Access	Open Loop Vector Access
D12-08	AFR Gain	Enable/Disable Hunt Prevention function	0.0–10.00	1.0	–	Adv
D12-09	AFR Time	Automatic frequency regulator time	0–2000 msec	50	–	Adv
D12-30	Carrier in tune	Sets the carrier frequency during auto-tuning		0	–	Adv
	<i>0</i>	<i>2kHz</i>				
	<i>1</i>	<i>Adjustable by D10-01 (Fc Upper Limit)</i>				

Motor Parameters

- E1 Voltage Frequency Pattern 1
- E2 Motor Set-up
- E3 Motor 2 Method
- E4 Motor 2 Voltage Frequency Pattern
- E5 Motor 2 Set-up

Voltage/Frequency Pattern

Input Voltage

The setting of E1-01 adjusts the voltage values of the preset V/f patterns (E1-03=0–E), when using the V/f control modes. This provides the optimum V/f pattern for the motor. Parameter E1-01 makes no adjustments to the V/f pattern when using the customer V/f pattern (E1-03=F) or when using the Open Loop Vector control modes.

Parmtr Code	Display	Function	Range	Initial ⁽²⁾ Value	V/F Access	Open Loop Vector Access
E1-01	Input Voltage	Sets input voltage	310~510V	230/460	User	User

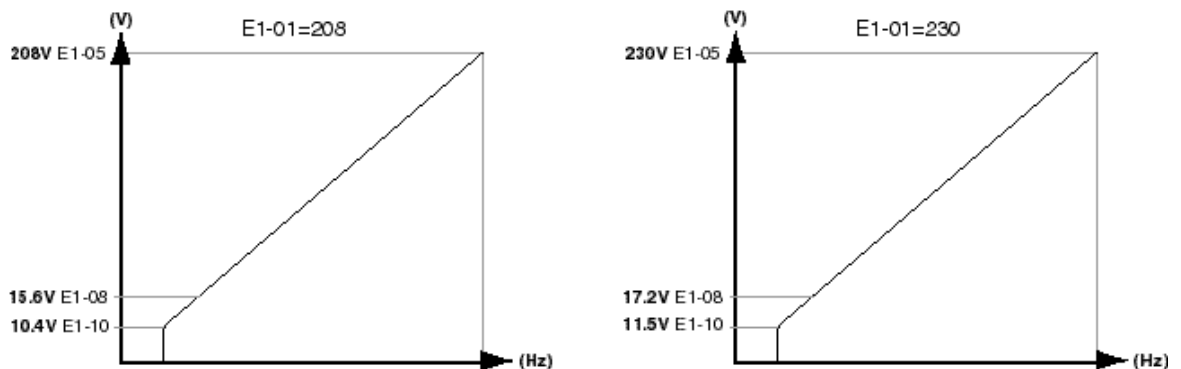

Figure 5-31: E1-01 Input Voltage

- When using open loop vector control mode, the V/f pattern voltage values will be adjusted by the Auto-Tuning function.
- Factory setting is 230 (230V units), 460 (460V units) and 575 (575V units).

The setting E1-01 adjusts the overvoltage level, braking transistor turn on level and the stall prevention level during deceleration.

Table 5.5

Inverter Voltage	E1-01 Setting	Overvoltage Trip		Braking Transistor		Stall Level
		Trip	Reset	On	Off	
230	150-255	400V	380V	380V	375V	380V
460	≥400	800V	760V	760V	750V	760V
460	<400	720V	680V	660V	650V	670V
575	>500V	1040V	990V	990V	970V	960V
575	<500V	990V	940V	860V	840V	830V

Parameter E1-01 performs the above mentioned function in all three control modes.

Parmtr Code	Display	Function	Range	Initial ⁽²⁾ Value	V/F Access	Open Loop Vector Access
E1-02	Motor Selection	Identifies motor as fan-cooled or blower-cooled		0	User	User
	<i>0 Std Fan Cooled</i>					
	<i>1 Std Blower Cooled</i>					
E1-03*	V/f Selection	Select preset V/f Pattern for operation in V/f mode only		00/04	User	-
	<i>0-E: Preset V/f Pattern can be selected</i>					
	<i>F: Custom V/f Pattern can be set (See Table 5.6)</i>					
E1-04	Max Frequency	Maximum Frequency “F”	40.0–400.0 Hz	60.0	User	User
E1-05 ⁽¹⁾	Max Voltage	Maximum Voltage “F”	0.0–510.0 V	230/460	User	User
E1-06	Base Frequency	Motor Base Frequency	0.0–400.0 Hz	60	User	–
E1-07	Mid Frequency A	Midpoint Output Frequency A	0.0–400.0 Hz	3.0	User	Adv
E1-08 ⁽¹⁾	Mid Voltage A	Midpoint Output Voltage A	0.0–510.0 Hz	39.0	User	Adv
E1-09	Min Frequency	Minimum Frequency	0.0–400.0 Hz	1.3/0.5	User	User
E1-10 ⁽¹⁾	Min Voltage	Minimum Voltage	0.0–510.0 V	22.2	User	Adv
E1-11	Mid Frequency B	Midpoint Output Frequency B	0.0–400.0 Hz	0.0	Adv	Adv
E1-12	Mid Voltage B	Midpoint Output Voltage B	0.0–510.0 V	0.0	Adv	Adv
E1-13 ⁽¹⁾	Base Voltage	Motor Base Voltage	0.0–510.0 V	460	Adv	User

* Initial value is determined by X-Press Programming tables 4-1 through 4-6.

⁽¹⁾ For 230V class units, the value is half that of 460V class units.

⁽²⁾ The initial value displayed here is for 400V class drives, and set to Open Loop Vector (AI-02=2).

Table 5.6: Voltage/Frequency Pattern Options

E1-03⁽¹⁾	E1-04	E1-05*	E1-06	E1-07	E1-08*	E1-09	E1-10*	E1-11	E1-12	E1-13*
<i>00</i>	60.0 Hz	460V	60.0 Hz	3.0 Hz	29.9V	1.3 Hz	16.1V	0.0 Hz	0.0V	460V
<i>01</i>	60.0 Hz	460V	60.0 Hz	3.0 Hz	32.2V	1.3 Hz	18.4V	0.0 Hz	0.0V	460V
<i>02</i>	60.0 Hz	460V	60.0 Hz	3.0 Hz	34.5V	1.3 Hz	20.7V	0.0 Hz	0.0V	460V
<i>03</i>	60.0 Hz	460V	60.0 Hz	3.0 Hz	36.8V	1.3 Hz	23.0V	0.0 Hz	0.0V	460V
<i>04</i>	60.0 Hz	460V	60.0 Hz	3.0 Hz	39.1V	1.3 Hz	25.3V	0.0 Hz	0.0V	460V
<i>05</i>	60.0 Hz	460V	60.0 Hz	3.0 Hz	41.4V	1.3 Hz	27.6V	0.0 Hz	0.0V	460V
<i>06</i>	60.0 Hz	460V	60.0 Hz	3.0 Hz	43.7V	1.3 Hz	29.9V	0.0 Hz	0.0V	460V
<i>07</i>	72.0 Hz	460V	60.0 Hz	3.0 Hz	32.2V	1.3 Hz	18.4V	0.0 Hz	0.0V	460V
<i>08</i>	72.0 Hz	460V	60.0 Hz	3.0 Hz	35.6V	1.3 Hz	21.8V	0.0 Hz	0.0V	460V
<i>09</i>	72.0 Hz	460V	60.0 Hz	3.0 Hz	39.1V	1.3 Hz	25.3V	0.0 Hz	0.0V	460V
<i>0A</i>	90.0 Hz	460V	60.0 Hz	3.0 Hz	32.2V	1.3 Hz	18.4V	0.0 Hz	0.0V	460V
<i>0B</i>	90.0 Hz	460V	60.0 Hz	3.0 Hz	35.6V	1.3 Hz	21.8V	0.0 Hz	0.0V	460V
<i>0C</i>	90.0 Hz	460V	60.0 Hz	3.0 Hz	39.1V	1.3 Hz	25.3V	0.0 Hz	0.0V	460V
<i>0D</i>	120.0 Hz	460V	60.0 Hz	3.0 Hz	32.2V	1.3 Hz	18.4V	0.0 Hz	0.0V	460V
<i>0E</i>	120.0 Hz	460V	60.0 Hz	3.0 Hz	39.1V	1.3 Hz	25.3V	0.0 Hz	0.0V	460V
<i>0F⁽²⁾</i>	60.0 Hz	460V	60.0 Hz	3.0 Hz	34.5V	1.3 Hz	20.7V	0.0 Hz	0.0V	460V

* For 230V Class units, the value is half that of 460V class units.

⁽¹⁾ By setting E1-03 (you only are concerned with the first digit from the right), you are also programming E1-04 through E1-13.

⁽²⁾ When you select "0F"—and only when you select "0F"—you can change the value of E1-04.

Motor Set-up

E2 constants define motor parameters. Normally, the default settings for E2 constants are determined by KVA selection (O2-04). If the control is Open Loop Vector (A1-02=2), the E2 constants will be set automatically during auto-tuning. If the control method is V/F (A1-02=0), the motor rated current should be entered into E2-01.

If auto-tuning cannot be performed, some E2 constants can be calculated using the motor's nameplate information.

Motor rated slip frequency (E2-02) can be calculated by using the following equation:

$$f_s = f - \frac{(N \cdot P)}{120}$$

Where... f_s : slip frequency (Hz)
 f : rated frequency (Hz)
 N : rated motor speed (rpm)
 P : number of motor poles

Motor terminal resistance E2-05 can be calculated by using the following equation:

$$r_t = r_p \cdot \frac{273 + (25^\circ\text{C} + T_i)/2}{273 + T_i}$$

Where... r_t : motor terminal resistance
 r_p : Phase-to-Phase resistance at insulation class temperature
 T_i : insulation class temperature ($^\circ\text{C}$)

Parmtr Code	Display	Function	Range	Initial Value	V/F Access	Open Loop Vector Access
E2-01	Motor Rated FLA	Motor-rated current	0.01–1500.0 A	*	User	User
E2-02	Motor Rated Slip	Motor-rated slip frequency	0.00–20.00 Hz	*	Adv	User
E2-03	No-Load Current	Motor no-load current	0.0–1500.0 A	*	Adv	User
E2-05	Term Resistance	Motor terminal resistance	0.000–65.000 Ω	*	Adv	Adv
E2-06	Leak Inductance	Leakage Inductance	0.0–30.0%	*	–	Adv
E2-07	Saturation Comp 1	Core-Saturation Compensation Coefficient 1	0.00–0.50	*	–	Adv
E2-08	Saturation Comp 2	Core-Saturation Compensation Coefficient 2	0.00–0.75	*	–	Adv

* Initial value is determined by O2-04 (kVA Selection)

Motor 2 Method

The Motor 2 method function allows one drive to control two separate motors which are coupled to separate motions. The output of the drive is switched from one motor to the other and a multi-function input (H1-XX=3D Motor 2 Select) informs the drive of which motor is being used.



WARNING

Do not switch between motors when the drive's output is on as it will damage the unit!

Parmtr Code	Display	Function	Range	Initial Value	V/F Access	Open Loop Vector Access
E3-01	Control Method <i>0 V/f control</i> <i>2 Open loop vector</i>	Motor 2 control method	0–2	2	Adv	Adv
E3-02	Motion 2 <i>0 Traverse</i> <i>1 Standard Hoist</i>	Motor 2 motion	0–2	1	Adv	Adv

Motor 2 Voltage/Frequency Pattern

Parmtr Code	Display	Function	Range	Initial Value	V/F Access	Open Loop Vector Access
E4-01	V/f 2 Max freq	Maximum frequency for Motor 2	40.0–400.0 Hz	60.0	Adv	Adv
E4-02	V/f 2 Max voltage	Maximum voltage for Motor 2	0.0–255.0 V	230/460	Adv	Adv
E4-03	V/f 2 Base Freq	Base frequency for Motor 2	50.0–400.0 Hz	60.0	Adv	Adv
E4-04	V/f 2 Mid Freq	Midpoint output frequency for Motor 2	0.0–400.0 Hz	3.0	Factory	Factory
E4-05	V/f 2 Mid Voltage	Midpoint output voltage for Motor 2	0.0–255.0 V	12.6	Factory	Factory
E4-06	V/f 2 Min Freq	Minimum output frequency for Motor 2	0.0–400.0 Hz	0.5	Factory	Factory
E4-07	V/f 2 Min Voltage	Minimum output voltage for Motor 2	0.0–255.0 V	2.3	Factory	Factory

Motor 2 Set-up

Parmtr Code	Display	Function	Range	Initial Value	V/F Access	Open Loop Vector Access
E5-01	Motor2 Rated FLA	Motor-rated current for Motor 2	0.0–150.0 A	*	Adv	Adv
E5-02	Motor2 Slip Freq	Motor-rated slip frequency for Motor 2	0.00–20.0 Hz	*	Adv	Adv
E5-03	Motor2 No Load 1	Motor no-load current for Motor 2	0.0–150.0 A	*	Adv	Adv
E5-05	Motor2 Term Ohms	Motor terminal resistance for Motor 2	0.000–65.000Ω	*	Adv	Adv
E5-06	Motor2 Leak	Leakage inductance for Motor 2	0.0–30.0%	*	–	Adv

* *Based upon inverter models*

Option Parameters

- F2 Analog Input 14 Set-up
- F3 Digital Input Option Set-up
- F4 Analog Output Option Set-up
- F5 Digital Output 2 Set-up
- F6 Digital Output 8 Set-up
- F7 PO-36F Set-up

Analog Input 14 Set-up

Sets CH1 to CH3 input functions when AI-14B option is connected (2CN).

When the 3CH individual input is used, parameter B3-01 is automatically set to “1” (frequency reference from control circuit terminal). The option/inverter reference selection, which is selected by a multi-function contact input (H1-XX= “1E”), is disabled when using the AI-14B option.

Parmtr Code	Display	Function	Range	Initial Value	V/F Access	Open Loop Vector Access
F2-01	AI-14 Input Sel	Determines whether the 3-channel input selection is individual or additional		0	Adv	
	0	3ch Individual*				
	1	3ch Additional*				

*

Setting	Function	CH1 (TC1 to TC4)	CH2 (TC2 to TC4)	CH3 (TC3 to TC4)
0	3-channel individual input (factory default)	Substitute for terminals 13 & 17	Substitute for terminals 14 & 17	Substitute for terminals 16 & 17
1	3-channel additional input	Sum of CH1 to CH3 input values is used as the frequency reference value		

Digital Input Option Set-up

Selects the setting mode of the frequency reference input from the DI-08 and DI-16H options.

Parmtr Code	Display	Function	Range	Initial Value	V/F Access	Open Loop Vector Access
F3-01	DI Option Setup	Selects the setting mode of the reference input from the DI-08 and DI-16H options	0-7	0	Adv	Adv
	0	BCD 1% unit				
	1	BCD 0.1% unit				
	2	BCD 0.01% unit				
	3	BCD 1Hz unit				
	4	BCD 0.1Hz unit				
	5	BCD 0.01Hz unit				
	6	Binary				
		DI-08:	255/100%			
		DI-16H, 12 bit selection:	4096/100%			
		DI-16H, 16 bit selection:	30000/100%			
	7	Binary—set value is displayed in decimal notation				

Analog Output Option Set-up

Selects the analog output monitors for channel 1 and 2 if AO-08 and AO-12 optional card is connected to 3CN.

Parmtr Code	Display	Function	Range	Initial Value	V/F Access	Open Loop Vector Access
F4-01	AO Ch1 Select	Analog output option Channel 1 selection	1–35	2	Adv	Adv
	1 <i>Frequency Ref</i>					
	2 <i>Output Freq</i>					
	3 <i>Output Current</i>					
	5 <i>Motor Speed</i>	(Open Loop Vector)				
	6 <i>Output Voltage</i>					
	7 <i>DC Bus Voltage</i>					
	8 <i>Output kWatts</i>					
	9 <i>Torque Reference</i>	(Open Loop Vector)				
	15 <i>Term 13 Level</i>					
	16 <i>Term 14 Level</i>					
	17 <i>Term 16 Level</i>					
	18 <i>Mot SEC Current</i>					
	19 <i>Mot EXC Current</i>	(Open Loop Vector)				
	20 <i>SFS Output</i>					
	24 <i>PID Feedback</i>					
	26 <i>Voltage Ref (Vq)</i>	(Open Loop Vector)				
	27 <i>Voltage Ref (Vd)</i>	(Open Loop Vector)				
	29 <i>Load Weight</i>	(No Function)				
	31 <i>Not used</i>					
	32 <i>ACR (q) Output</i>	(Open Loop Vector)				
	33 <i>ACR (d) Output</i>	(Open Loop Vector)				
	35 <i>Friction Torq</i>	(Open Loop Vector)				
F4-02	AO Ch1 Gain	Analog output Channel 1 multiplier	0–2.50	1.00	Adv	Adv
F4-03	AO Ch2 Select	Analog output option Channel 2 selection (Same as F4-01)	1–35	3	Adv	Adv
F4-04	AO Ch2 Gain	Analog output Channel 2 multiplier	0–2.50	0.50	Adv	Adv

Digital Output 2 Set-up

Selects the multi-function output selections for channels 1 and 2 of the DO-02 option card.

Parmtr Code	Display	Function	Range	Initial Value	V/F Access	Open Loop Vector Access
F5-01	DO-02 Ch1 Select	Determines the DO-02 digital output Channel 1 selection (Same as H2-01)	0–FF	0	Adv	Adv
F5-02	DO-02 Ch2 Select	Determines the DO-02 digital output Channel 2 selection (Same as H2-01)	0–FF	1	Adv	Adv

Digital Output 8 Set-up

Selects the multi-function output selections for the DO-08 option.

Parmtr Code	Display	Function	Range	Initial Value	V/F Access	Open Loop Vector Access
F6-01	DO-08 Selection	Selects Multi-Function Output Selections for the DO-08 option.		0	Adv	Adv
	0	<i>Sch Individual</i>				
	1	<i>Binary Output</i>				
	2	<i>Srl Com Output</i>				

Table 5.7

Setting	Terminal No.	Description
0 8-Channel individual (factory Default)	TD5/TD11	Overcurrent (SC, OC, GF)
	TD6/TD11	Overvoltage (OV)
	TD7/TD11	Inverter overload (OL2)
	TD8/TD11	Fuse blown (FU)
	TD9/TD11	Not used
	TD10/TD11	Inverter overheat (OH)
	TD1/TD2	During zero-speed detection
	TD3/TD4	During speed agree
1 binary output	TD5/TD11	Binary output*
	TD6/TD11	
	TD7/TD11	
	TD8/TD11	
	TD9/TD11	During zero-speed detection
	TD10/TD11	During speed agree
	TD1/TD2	During run
	TD3/TD4	Minor fault

* When F6-01 is set to binary output (setting = "1"), use the table on the following page to read the DO-08 output.

Table 5.8

TD8/TD11 (bit 3)	TD7/TD11 (bit 2)	TD6/TD11 (bit 1)	TD5/TD11 (bit 0)	Description
0	0	0	0	No Fault
0	0	0	1	Overcurrent (SC, OC, GF)
0	0	1	0	Overvoltage (OV)
0	0	1	1	Inverter overload (OL2)
0	1	0	0	Inverter overheat (OH)
0	1	0	1	Overspeed (OS)
0	1	1	0	Fuse blown (FU)
0	1	1	1	Not used
1	0	0	0	External fault (EF3~EF8)
1	0	0	1	Controller fault
1	0	1	0	Motor overload (OL1)
1	0	1	1	Not used
1	1	0	0	Power loss (UV1, UV2, UV3)
1	1	0	1	Excessive speed deviation (DEV)
1	1	1	0	PG disconnection (PGO)
1	1	1	1	Not used

NOTE: When the terminal is open, the bit setting is “0”; when the terminal is close, the bit setting is “1”.

PO-36F Set-up

The PO-36F option card outputs pulse signals that correspond to the inverter’s output frequency.

Parmtr Code	Display	Function	Range	Initial Value	V/F Access	Open Loop Vector Access
F7-01	PO-36F Selection	Sets the number of pulse signals to be output from the PO-36F option		1	Adv	Adv
	0	Output Freq x 1				
	1	Output Freq x 6				
	2	Output Freq x 10				
	3	Output Freq x 12				
	4	Output Freq x 36				

Terminal Parameters

- H1 Digital Inputs
- H2 Digital Outputs
- H3 Analog Inputs
- H4 Analog Outputs
- H5 Serial Communication Set-up

Digital Inputs

The IMPULSE•G+ Series 2 has six multi-function contact inputs for the set-up of numerous functions. The following table lists the function selections for the multi-function contact inputs (terminals 3 to 8) and indicates the control modes during which each function can be enabled. An OPE03 error will occur if a function is programmed in more than one terminal at the same time.

NOTE: These parameters change automatically when A1-03 and A1-04 are changed. Refer to parameters changed by X-Press Programming on page 4-11 to 4-13.

Parmtr Code	Display	Function	Ref Page Number	Range	Initial Value	V/F Access	Open Loop Vector Access
H1-01	Terminal 3 Sel (parameter)	Selects the multi-function inputs.			0	Adv	Adv
H1-02	Terminal 4 Sel (parameter)	Same as H1-01		0-45	1	Adv	Adv
H1-03	Terminal 5 Sel (parameter)	Same as H1-01		0-45	7	Adv	Adv
H1-04	Terminal 6 Sel (parameter)	Same as H1-01		0-45	9	Adv	Adv
H1-05	Terminal 7 Sel (parameter)	Same as H1-01		0-45	24	Adv	Adv
H1-06	Terminal 8 Sel (parameter)	Same as H1-01		0-45	E	Adv	Adv
	0 Multi-Step Ref 2	Multi-Step Speed 2.	5-3				
	1 Multi-Step Ref 3	Multi-Step Speed 3.	5-3				
	2 Multi-Step Ref 4	Multi-Step Speed 4.	5-3				
	3 Multi-Step Ref 5	Multi-Step Speed 5.	5-3				
	4 Speed Hold 2	Hold function (2nd step of Three-Step Infinitely Variable).	4-10				
	5 Accel Command	Acceleration function (2nd step of Two-Step Infinitely Variable or 3rd step of Three-Step Infinitely Variable).	4-10				

6	Upper Lmt 1 N/O	Upper Limit–SLOW DOWN; Normally Open	5-23
7	Upper Lmt 2 N/O	Upper Limit–STOP; Normally Open	5-23
8	Lower Lmt 1 N/O	Lower Limit–SLOW DOWN; Normally Open	5-23
9	Lower Lmt 2 N/O	Lower Limit–STOP; Normally Open	5-23
A	Upper Lmt 1 N/C	Upper Limit–SLOW DOWN; Normally Closed	5-23
B	Upper Lmt 2 N/C	Upper Limit–STOP; Normally Closed	5-23
C	Lower Lmt 1 N/C	Lower Limit–SLOW DOWN; Normally Closed	5-23
D	Lower Limit 2 N/C	Lower Limit–STOP; Normally Closed	5-23
E	M-Speed Gain 1	Micro-Positioning Control Multiplier 1	5-22
F	Not used	No function	n/a
10	M-Speed Gain 2	Micro-Positioning Control Multiplier 2	5-22
13	Ultra/Swift Lift	Ultra-Lift enable	5-27
14	Torque Lmt Acc/Dec	Torque Limit Acceleration/ Deceleration	5-16
15	Alt T-Lim Gain	Alternate Torque Limit Multiplier	5-29
16	Forward Jog	Jog Control FORWARD command	5-3
17	Reverse Jog	Jog Control REVERSE command	5-3
18	Forward Inch	Inch Control	5-35
19	Reverse Inch	Inch Control	5-35
1A	Inch Repeat	Inch Control	5-35
1B	Multi-Acc/Dec 1	Acceleration and Deceleration Changeover Time	5-14
1C	Reference SW	Analog/Digital Reference Changeover. B1-10=1. Open=Analog Closed=Digital	5-3
1D	Term 13/16 Switch	Terminal 13/16 Switch	4-10, 5-68 and 5-69
1E	Option/Inv Sel	Option/Inverter Speed Reference Changeover (Option Speed Reference at closed)	4-10
1F	Program Lockout	Program Lockout	n/a
24	External Fault	See “External Fault response selection”	5-67
30	Term 13/14 Switch	Terminal 13/14 Switch	4-10, 5-68 and 5-69
31	Fault Reset N/O	Fault Reset; Normally Open	n/a
32	Fault Reset N/C	Fault Reset; Normally Closed	n/a
34	Trim Ctl Increase	Trim Control Increase	5-13
35	Trim Ctl Decrease	Trim Control Decrease	5-13

36	<i>Brake Ans Back</i>	<i>Brake Answer-Back</i>	5-29
37	<i>Ext BaseBlk N/O</i>	<i>Immediate Stop at STOP Command; Normally Open</i>	n/a
38	<i>Ext BaseBlk N/C</i>	<i>Immediate Stop at STOP Command; Normally Closed</i>	n/a
3D	<i>Motor Select</i>	<i>Motor 2 enabled</i>	5-52
40	<i>*BE6 Up Speed Lmt</i>	<i>Limits Speed to Frequency Set in C8-17</i>	
41	<i>DCInj Activate</i>	<i>DC Injection Brake</i>	5-36
43	<i>Alt S-Ref UpLmt</i>	<i>Alternate Upper Limit Frequency Reference</i>	5-5
45	<i>Serial/Inv Swtch</i>	<i>Serial/Inverter Run and Speed Reference Changeover</i>	n/a

* Available only in software versions 14910-14911.

Digital Outputs

The IMPULSE•G+ Series 2 has three multi-function control outputs for indicating various conditions. The following table lists the function selections for the multi-function contact output (terminals 9, 25, and 26), and indicates the control modes during which each function can be enabled. Note that Terminals 25 and 26 are Terminals 1 and 2 respectively on G5OUT option card.

Parmtr Code	Display	Function	Range	Reference Page Number	Initial Value	V/F Access	Open Loop Vector Access
H2-01	Terminal 9 Sel	Assigns one of the following 48 multi-function digital output parameters to Terminal 9, 25, or 26.	0–40	--	0	Adv	Adv
H2-02	Terminal 25 Sel	Terminal 1 on the G5OUT Option Card	0–40	--	0	Adv	Adv
H2-03	Terminal 26 Sel	Terminal 2 on the G5OUT Option Card	0–40	--	7F	Adv	Adv
	0 Brake Output	Closed when voltage or frequency is output		n/a			
	1 Zero Speed	Closed when below B2-02 or D1-01					
	2 Fref/Fout Agree 1	Output when Frequency Reference and Frequency Output agree		5-79			
	3 Fref/Set Agree 1	Output when Ouput Frequency Reference equals L4-01.		5-79			
	4 Freq Detect 1	Closed when output frequency is < L4-01.		5-79			
	5 Freq Detect 2	Closed when output frequency is > L4-01.		5-79			
	6 Inverter Ready	Closed when an inverter is not in a fault state		n/a			
	7 DC Bus Undervolt	Closed when DC Bus voltage drops below UV trip point.		6-9			
	8 BaseBlk 1	Closed when the inverter is not outputting voltage.		n/a			
	9 Option Reference	Closed when the frequency reference is input from the digital operator.		5-90			
	A Remote Operation	Closed when the RUN command is input from the digital operator.		5-90			
	B Trq Det 1 N.O.	Output when torque > L6-02		5-81			
	C Loss of Ref	Closed when inverter has detected a loss of frequency reference		5-80			
	D DB Overheat	Closed when inverter displays "RH" or "RR" fault.		n/a			
	E Fault	Closed during a major fault.		6-3			
	F Not Used	No function		n/a			
	10 Minor Fault	Closed during minor fault or alarm.		6-3			

Parmtr Code	Display	Function	Range	Reference Page Number	Initial Value	V/F Access	Open Loop Vector Access
11	Reset Cmd Active	Closed when a reset command is present on the terminals		n/a			
13	Fref/Fout Agree 2	Closed when output frequency = frequency reference		5-79			
14	Fref/Set Agree 2	Closed when output frequency = L4-03		5-80			
15	Freq Detect 3	Closed when output frequency is \leq L4-03		5-80			
16	Freq Detect 4	Closed when output frequency \geq L4-03		5-80			
17	Trq Det 1 N.C.	Open when torque > L6-02		5-81			
18	Trq Det 2 N.O.	Closed when torque > L6-05		5-83			
19	Trq Det 2 N.C.	Open when torque > L6-05		5-83			
1A	Forward Dir	Closed at FWD/UP command		n/a			
1B	Reverse Dir	Closed at REV/DOWN command		n/a			
1C	Speed Increasing	Closed when speed is increasing		n/a			
1D	BaseBlk 2 (N.C.)	Open when inverter is not outputting voltage.		n/a			
1E	Motor A/B Change	Closed when motor changeover is input to terminals		n/a			
20	Auto-Rst Enabled	Auto-Reset Enabled		5-85			
21	Overload (OL1)	OL1 Overload fault code		6-7			
22	OH Prealarm	Closed when "OH" is displayed on keypad		6-7			
30	Current Trq LIM	Current Torque Limit		n/a			
34	During RUN 2	During Run 2 - ON: Frequency output, OFF: Base block, DC injection braking, initial excitation		n/a			
35	Load Check Fault	Load Check fault output		5-25			
36	Slack Cable Det	Slack Cable Detection output		n/a			
37	Upper Lmt input	Closed when upper limit slowdown or upper limit stop is input		5-23			
38	Lower Lmt input	Closed when lower limit slowdown or lower limit stop is input		5-23			
39	Up/Low Lmt input	Closed when upper limit slowdown or upper limit stop or lower limit slowdown or lower limit stop is input		5-23, 5-24			
3B	During RUN 1	Output for RUN 1		n/a			
40	Fault Annunciate	Closed on specified faults.		5-65			

Digital Outputs—Fault Annunciate (H2-01~03=40)

Digital Outputs—Fault Annunciate enables you to assign a set of six fault outputs to Terminals 1 and/or Terminal 2 on the G5out card. In addition, you can select whether each fault output is enabled.

*NOTE: Terminal 9 can also be used for **Digital Outputs—Fault Annunciate**; however, it is normally assigned to a brake output.*

Before you start to program this feature, you may find it convenient to first photocopy the “Binary-to-Hexadecimal Conversion Worksheet” in this section. By being able to write in the worksheet’s boxes, you will find it easier to program the feature.

Programming **Digital Outputs—Fault Annunciate** requires that you determine two 4-digit binary numbers and then convert these numbers to two 1-digit hexadecimal numbers. You enter the hexadecimal numbers when you program the drive.

To program **Digital Outputs—Fault Annunciate** (assuming you are in **Programming Mode**):

1. Press the **UP** button until

Group H
Terminal

 appears.
2. Press the **DATA/ENTER** button.

Function H1
Digital Inputs

 appears.
3. Press the **UP** button.

Function H2
Digital Outputs

 appears.
4. Determine the output terminal to which you want **Fault Annunciate** assigned; Terminal 9, 25, or 26.
5. Press the **DATA/ENTER** button.

Terminal 9 Sel
XXXXXXXXXX

 appears. If you want Terminal 25 or 26, press the **UP** button until it appears. Assume you are using Terminal 9.
6. Press the **DATA/ENTER** button.

H2-01=X***
XXXXXXXXXX

 appears.
7. Press the **UP** or **DOWN** button until

H2-01=40
Fault Annunciate

 appears.
8. Press the **DATA/ENTER** button.

Fault Data Input
00

 appears.

9. From the following worksheet, select one of three fault output sets. (Each row is a set.)

Enter the one-zero combination that corresponds to the set (row) that you selected.

For example, if you selected Set 2, you would enter “1 0” in the first two columns from the left, which would represent the first two digits of the first binary number that you would convert later.

Table 5.9: Binary-to-Hexadecimal Conversion Worksheet

	First digit from the left				Second digit from the left			
	<input type="checkbox"/> 1 or 0	<input type="checkbox"/> 1 or 0	<input type="checkbox"/> 1 or 0	<input type="checkbox"/> 1 or 0	<input type="checkbox"/> 1 or 0	<input type="checkbox"/> 1 or 0	<input type="checkbox"/> 1 or 0	<input type="checkbox"/> 1 or 0
Set 1	1	1	BE7	BE5	BE4	BE0	OL2	OL1
Set 2	1	0	OS	DEV	LL1	LL2	UL1	UL2
Set 3	0	1	BE6	BE5	BE4	BE3	BE2	BE1

10. Determine which fault outputs should be enabled. To enable a fault output, enter 1 in the box above the fault output; otherwise, enter 0. Do this for each fault output in the set.

For example, if Set 2 is selected and LL1 and UL1=1, “1 0 0 0” and “1 0 1 0 “ would be the two 4-digit binary numbers.

11. Using the conversion table below, determine the 1-digit hexadecimal number for both 4-digit binary numbers

Table 5.10

Binary Number	Hexadecimal Number
0000	0
0001	1
0010	2
0011	3
0100	4
0101	5
0110	6
0111	7
1000	8
1001	9
1010	A
1011	B
1100	C
1101	D
1110	E
1111	F

Continuing with the example, “1 0 0 0” and “1 0 1 0 “ converts to “8A.”

12. Press the **UP** or **DOWN** button until the appropriate hexadecimal number appears for XX on

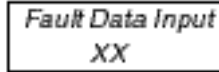

External Fault Response Selection

It is sometimes desirable to have at least one external fault input to the drive. To properly program a multi-function input (H1-01 to H1-06) for this purpose an external fault response must be selected. The table below shows the possible selections for an external fault response.

Table 5.11

External Fault Selection								Setting Result
Input Level Selection		Detection Method		External Fault Action				
N.O.	N.C.	Always	During Run	Ramp to Stop	Coast to Stop	Fast-stop*	Alarm Only	
√		√		√				20
√		√			√			24
√		√				√		28
√		√					√	2C
√			√	√				22
√			√		√			26
√			√			√		2A
√			√				√	2E
	√	√		√				21
	√	√			√			25
	√	√				√		29
	√	√					√	2D
	√		√	√				23
	√		√		√			27
	√		√			√		2B
	√		√				√	2F

* Uses B5-08 timer

NOTES:

1. N.O. = normally open contact; N.C. = normally closed contact
2. Setting “24” is the factory default.

Analog Inputs

The IMPULSE•G+ Series 2 has three analog inputs (two multi-function and one reference) for the external input of numerous references and limits.

* Initial value is determined by X-Press Programming (Table 4.1-4.6)

Parltr Code	Display	Function	Range	Initial Value	V/F Access	Open Loop Vector Access
H3-01*	Term 13 Signal	Selects the type of voltage signal input at terminal 13		0	Adv	Adv
	0 OVDC to 10VDC					
	1 -10VDC to +10VDC					
H3-02	Terminal 13 Gain	Gain multiplier for Terminal 13 analog input signal	0-1000.0%	100.0	Adv	Adv
H3-03	Terminal 13 Bias	Bias multiplier for Terminal 13 analog input signal	-100.0 - 100.0%	0.0	Adv	Adv
H3-04	Term 16 Signal	Selects the type of voltage signal input at terminal 16	0-1	0	Adv	Adv
	0 OVDC to 10VDC					
	1 -10VDC to +10VDC					
H3-05	Terminal 16 Sel	Assigns one of the following function analog input parameters to Terminal 16		0	Adv	Adv
	0 Aux Reference	Auxiliary Reference				
	1 Frequency Gain	Frequency Gain				
	2 Frequency Bias	Frequency Reference Bias				
	4 Voltage Bias	Voltage Bias (V/F)				
	5 Acc/Dec Change	Acceleration/Deceleration Changeover				
	6 DC Brake Current	DC Injection Braking Current				
	7 Overtorque Level	Overtorque Detection Level				
	8 Stall Prev Level	Stall Prevention Level (V/F)				
	9 Ref Lower Limit	Speed Reference Lower Limit				
	A Jump Frequency	Jump Frequency				
	B PID Feedback	Proportional, Integral, and Derivative (PID) Control Feedback				
	10 Forward Torque Limit	(Open Loop Vector)				
	11 Reverse Torque Limit	(Open Loop Vector)				
	12 Regen Torque Limit	(Open Loop Vector)				
	15 FWD/REV T Limit	Forward/Reverse Torque Limit				
	16 Term 16 SW Ref	Switching Level Reference for Terminal 16				
	1F Not Used	Not Used				
H3-06	Terminal 16 Gain	Gain multiplier for Terminal 16 analog input signal	0000.0–1000.0%	100.0	Adv	Adv

Parmtr Code	Display	Function	Range	Initial Value	V/F Access	Open Loop Vector Access
H3-07	Terminal 16 Bias	Bias multiplier for Terminal 16 analog input signal	-100.0–100.0%	0.0	Adv	Adv
H3-08	Term 14 Signal	Selects the type of signal input at terminal 14.	0-2	2	Adv	Adv
	0	0 to +10VDC				
	1	-10 to +10VDC				
	2	4 to 20mA				
H3-09	Terminal 14 Sel	Assigns one of the following function analog input parameters to Terminal 14.		1F	Adv	Adv
	0	<i>Aux Reference</i>	<i>Auxiliary Reference</i>			
	1	<i>Frequency Gain</i>	<i>Frequency Gain</i>			
	2	<i>Frequency Bias</i>	<i>Frequency Reference Bias</i>			
	4	<i>Voltage Bias</i>	<i>Voltage Bias (V/F)</i>			
	5	<i>Acc/Dec Change</i>	<i>Acceleration/Deceleration Changeover</i>			
	6	<i>DC Brake Current</i>	<i>DC Injection Braking Current</i>			
	7	<i>Overtorque Level</i>	<i>Overtorque Detection Level</i>			
	8	<i>Stall Prev Level</i>	<i>Stall Prevention Level (V/F)</i>			
	9	<i>Ref Lower Limit</i>	<i>Speed Reference Lower Limit</i>			
	A	<i>Jump Frequency</i>	<i>Jump Frequency</i>			
	B	<i>PID Feedback</i>	<i>Proportional, Integral, and Derivative (PID) Control Feedback</i>			
	10	<i>Forward Torque Limit</i>	<i>(Open Loop Vector)</i>			
	11	<i>Reverse Torque Limit</i>	<i>(Open Loop Vector)</i>			
	12	<i>Regen Torque Limit</i>	<i>(Open Loop Vector)</i>			
	15	<i>FWD/REV T Limit</i>	<i>Forward/Reverse Torque Limit</i>			
	1F	<i>Not Used</i>	<i>Not Used</i>			
H3-10	Terminal 14 Gain		0000.0–1000.0%	100.0	Adv	Adv
H3-11	Terminal 14 Bias		-100.0–100.0%	0.0	Adv	Adv
H3-12	Filter Avg Time	Filter average time	0.00–2.00sec	0.00	Adv	Adv

Analog Outputs

The IMPULSE•G+ Series 2 has two analog outputs for the external monitoring of drive conditions.

Parmtr Code	Display	Function	Range	Initial Value	V/F Access	Open Loop Vector Access
H4-01	Terminal 21 Sel	Assigns one of the following function analog output parameters to Terminal 21		2	Adv	Adv
	1 <i>Frequency Ref</i>					
	2 <i>Output Freq</i>					
	3 <i>Output Current</i>					
	5 <i>Motor Speed</i>	(Open Loop Vector)				
	6 <i>Output Voltage</i>					
	7 <i>DC Bus Voltage</i>					
	8 <i>Output kWatts</i>					
	9 <i>Torque Reference</i>	(Open Loop Vector)				
	15 <i>Term 13 Level</i>					
	16 <i>Term 14 Level</i>					
	17 <i>Term 16 Level</i>					
	18 <i>Mot SEC Current</i>					
	19 <i>Mot EXC Current</i>	(Open Loop Vector)				
	20 <i>SFS Output</i>					
	24 <i>PID Feedback</i>					
	26 <i>Voltage Ref (Vq)</i>	(Open Loop Vector)				
	27 <i>Voltage Ref (Vd)</i>	(Open Loop Vector)				
	29 <i>Load Weight</i>					
	31 <i>Not Used</i>					
	32 <i>ACR (q) Output</i>	(Open Loop Vector)				
	33 <i>ACR (d) Output</i>	(Open Loop Vector)				
	35 <i>Friction Torq</i>	(Open Loop Vector)				
H4-02	Terminal 21 Gain		0.00–2.50	1.00	Adv	Adv
H4-03	Terminal 21 Bias		-10.0–10.0	0.0	Adv	Adv
H4-04	Terminal 23 Sel	Sames as H4-01 except assigned to Terminal 23		3	Adv	Adv
H4-05	Terminal 23 Gain		0.00–2.50	1.00	Adv	Adv
H4-06	Terminal 23 Bias		-10.0–10.0%	0.0	Adv	Adv
H4-07	AO Level Select			0	Adv	Adv
	0 <i>0 to +10VDC</i>					
	1 <i>-10 to +10VDC</i>					

Serial Communication Set-up

The IMPULSE•G+ Series 2 uses communication port 6CN to communicate via MODBUS protocol.

Parmtr Code	Display	Function	Range	Initial Value	V/F Access	Open Loop Vector Access
H5-01	Serial Com Adr	Serial communication address	0–20	1F	Adv	Adv
H5-02	Serial Baud Rate 0 1200 Baud 1 2400 Baud 2 4800 Baud 3 9600 Baud			3	Adv	Adv
H5-03	Serial Com Sel 0 No parity 1 Even parity 2 Odd parity	Determines stopping method or fault at a serial fault occurrence	0–2	0	Adv	Adv
H5-04	Serial Fault Set 0 Ramp to Stop 1 Coast to Stop 2 Fast-Stop 3 Alarm Only	Determines stopping method or fault at a serial fault occurrence (Decel to stop using B5-02) (Immediate stop) (Decel to stop using B5-08) (Operation continues and “CE Memobus Err” displays on keypad)		1	Adv	Adv
H5-05	Serial Flt Dtct 0 Disabled 1 Enabled	Determines whether Serial Fault Detection is enabled		1	Adv	Adv

NOTE: After changing any H5 parameter, power to the inverter must be cycled.

NOTE: After initial communication, if the inverter is not communicated with for 2 seconds, a communication fault will occur (CE Memobus ERR).

Protection Parameters

- L1 Motor Overload
- L3 Stall Prevention
- L4 Ref Detection
- L6 Torque Detection
- L8 Hardware Protection
- L9 Automatic Reset

Motor Overload

The IMPULSE•G+ Series 2 protects against motor overload with a UL-recognized, built-in electronic thermal overload function.

The electronic thermal overload function estimates motor temperature, based on inverter output current, frequency and time to protect the motor from overheating. When the thermal overload fault is activated, an “OL1” trip occurs shutting OFF the inverter output and preventing excessive overheating in the motor. As long as the inverter is powered up, it continues to calculate the motor temperature.

When operating with one inverter connected to one motor, an external thermal relay is not needed. When operating several motors with one inverter, use the internal thermal protection from the motor or install an external thermal overload relay on each motor. In this case, set parameter *L1-01* to “0.”

Parmtr Code	Display	Function	Range	Initial Value	V/F Access	Open Loop Vector Access
L1-01	MOL Fault Select	Enable/disable motor overload detection.		1	Adv	Adv
	<i>0 Disabled</i>					
	<i>1 Coast to Stop</i>	(Immediate stop)				
L1-02	MOL Time Const	Time for OL1 fault when motor current is $\geq 150\%$ of the motor rated current.	0.1–5.0 min	1.0	Adv	Adv

Stall Prevention



CAUTION

This function automatically adjusts the output frequency, acceleration and/or deceleration rates in order to continue operation without tripping or “stalling” the inverter.

Parmtr Code	Display	Function	Range	Initial Value	V/F Access	Open Loop Vector Access
L3-01	StallP Accel Sel	Enable/disable stall prevention during acceleration.		1	Adv	Adv
	0 <i>Disabled</i>	See table below.				
	1 <i>General Purpose</i>	See table below.				
	2 <i>Intelligent</i>	See table below.				

Table 5.12

Setting	Description
0 Disabled	Stall prevention/current limit during acceleration is disabled. The inverter increases the output frequency at the set acceleration rate. If the acceleration rate is too fast for the load condition, the inverter may trip on overcurrent (OC) or overload (OL).
1 General Purpose	Stall prevention/current limit during acceleration is enabled (factory default). The acceleration rate is automatically extended according to motor current to prevent stalling during acceleration. The acceleration time may be longer than the set value (B5-01).
2 Intelligent	Stall prevention/current limit during acceleration is enabled with an intelligent acceleration mode. By monitoring motor current, the acceleration is the shortest amount of time, regardless of the set acceleration time.

Parmtr Code	Display	Function	Range	Initial Value	V/F Access	Open Loop Vector Access
L3-02	StallP Accel Lvl	Stall prevention level during acceleration.	0–200%	150	Adv	Adv

The stall prevention/current limit level during acceleration is set as a percentage of inverter rated current. A setting of 200% disables current limit during acceleration. During acceleration, if the output current exceeds this current limit level (*L3-02*), acceleration stops and frequency is maintained. When the output current decreases below this current level (*L3-02*), acceleration restarts. See below, Figure 5-33.

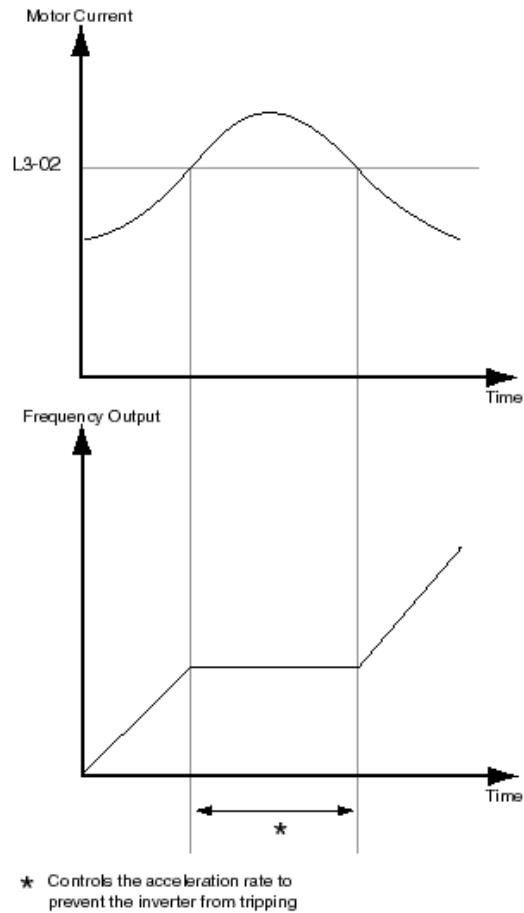

Figure 5-32: Stall Prevention/Current Limit During Acceleration

Parmtr Code	Display	Function	Range	Initial Value	V/F Access	Open Loop Vector Access
L3-03	StallP CHP Lvl	Stall prevention limit	0–100%	50	Adv	Adv

When a motor is used to the constant torque output area (constant HP), output frequency \geq maximum voltage output frequency (E1-06). In this area, the stall prevention/current limit level during acceleration is automatically reduced for smoother acceleration. This parameter limits the stall prevention/current limit level during acceleration in the constant output area so that it does not increase unnecessarily. The current limit level during acceleration is changed according to the following equation:

$$\boxed{\text{Current Limit Level During Accel in Constant Output Area}} = \boxed{\text{Current Limit Level During Acceleration (L3-02)}} \times \frac{\text{Max Voltage Output Frequency (E1-06)}}{\text{Output Frequency}}$$



CAUTION

This function automatically adjusts the output frequency, acceleration and/or deceleration rates in order to continue operation without tripping or “stalling” the inverter.

Parmtr Code	Display	Function	Range	Initial Value	V/F Access	Open Loop Vector Access
L3-04	StallP Decel Sel	Enable/Disable stall prevention during deceleration		0	Adv	Adv
	0 Disabled	See table below				
	1 General Purpose	See table below				
	2) Intelligent	See table below (V/F)				

If deceleration times are set too short for load conditions, the inverter automatically extends the deceleration time according to the main circuit DC bus voltage level. When using an optional braking resistor for the IMPULSE•G+ Series 2, set parameter L3-04 to “0”. See the Figure on the next page.

Table 5.13

Setting	Description
0 (Disabled)	Stall prevention during deceleration is disabled (factory default). An excessively short deceleration time will generate an overvoltage fault (OV), and the inverter will stop.
1 (General Purpose)	Stall prevention during deceleration is enabled. The DC bus voltage level is monitored, and the deceleration rate is automatically extended to prevent an overvoltage condition. This deceleration rate may be longer than the set value (B5-02).
2 (Int)	Stall prevention during deceleration is enabled with an intelligent deceleration mode. By monitoring DC bus voltage, the deceleration rate is automatically adjusted so that deceleration can be completed in the shortest amount of time, regardless of the set deceleration time.

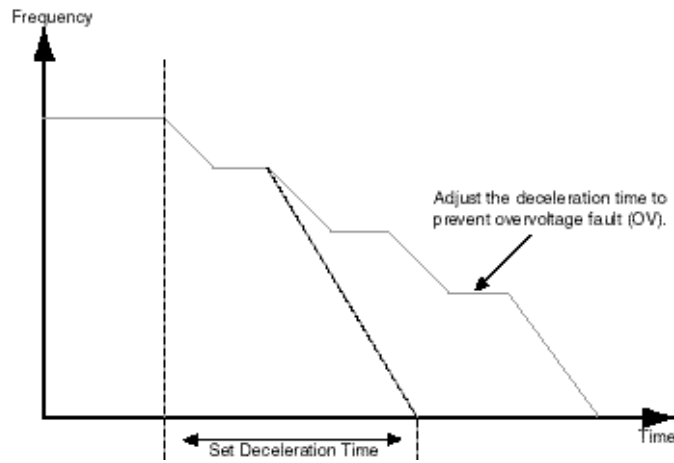

Figure 5-33: Stall Prevention During Deceleration

Parmtr Code	Display	Function	Range	Initial Value	V/F Access	Open Loop Vector Access
L3-05	StallP Run Sel	Enable/Disable stall prevention during running		1	Adv	–
	0 <i>Disabled</i>	See table below				
	1 <i>Decel Time 1</i>	See table below				
	2 <i>Decel Time 2</i>	See table below				

Sets a function to prevent stalling during an overload condition while running at constant speed.

Table 5.14

Setting	Description
0	Stall prevention/current limit during running is disabled.
1	Stall prevention/current limit during running is enabled (factory default). When the inverter output current exceeds the current limit level (L3-06) for more than 100ms during speed agree, the output frequency is decreased according to deceleration time 1 (B5-02). This can help prevent stalling. When the load condition is stabilized, the inverter accelerates to the previous frequency.
2	Stall prevention/current limit running is enabled as in setting “1”, however the output frequency is decreased according to deceleration time 2 (B5-04).

Parmr Code	Display	Function	Range	Initial Value	V/F Access	Open Loop Vector Access
L3-06	Stall Run Level	Stall prevention level during run.	30–200%	160	Adv	–

The stall prevention/current limit level during running is set as a percentage of inverter rated current. A setting of 200% disables current limit during running. During speed change, if the output current exceeds this current limit level (*L3-06*) during running, deceleration starts. When the output current decreases below this current limit level (*L3-06*), acceleration starts, up to the set frequency. See Figure 5-35 below.

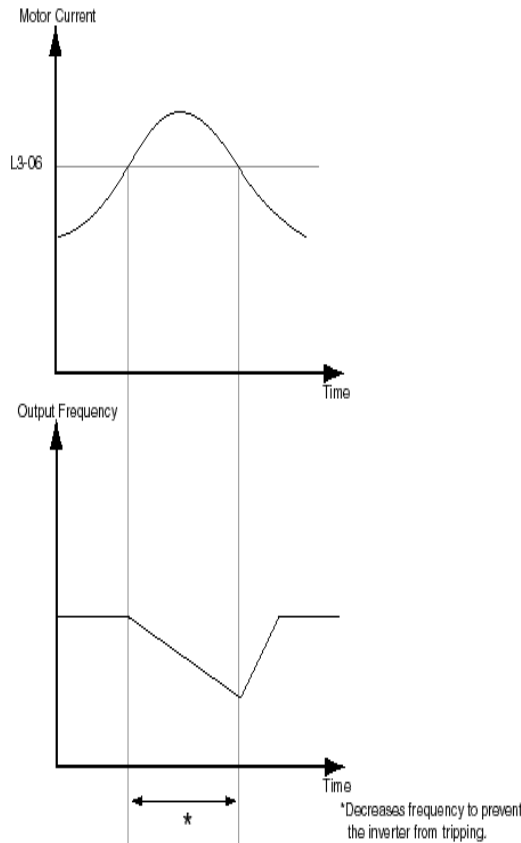

Figure 5-34: Stall Prevention/Current Limit During Running

Reference Detection

The IMPULSE•G+ Series 2 utilizes three different functions for detecting output frequency:

- When frequency agree is enabled using the multi-function contact outputs (H2-XX="2" or "13"), the contact closes whenever the output frequency "agrees" with the frequency reference, plus or minus the speed agree detection width.
- When desired frequency agree is enabled using the multi-function contact outputs (H2-XX="3" or "14"), the contact closes whenever the output frequency "agrees" with the speed agree detection level, plus or minus the speed agree detection width.
- When frequency detection is enabled using the multi-function contact outputs (H2-XX="4", "5", "15" or "16"), the contact closes whenever the output frequency is less than or more than the speed agree detection level, depending on which detection is selected.

L4-01 sets the detection level for the desired frequency agree 1 and frequency detection 1 and 2 functions. The set detection level is effective during both FWD and REV operation.

Parmtr Code	Display	Function	Range	Initial Value	V/F Access	Open Loop Vector Access
L4-01	Spd Agree Level	Speed Agree Level	0.0–150.0 Hz	0.0	Adv	Adv

L4-02 sets the detection width for frequency and desired frequency agree 1 and frequency detection 1 and 2 functions.

Parmtr Code	Display	Function	Range	Initial Value	V/F Access	Open Loop Vector Access
L4-02	Spd Agree Width	Speed Agree Width	0.0–20.0 Hz	2.0	Adv	Adv

L4-03 sets the detection level for the desired frequency agree 2 and frequency detection 3 and 4 functions. The set detection level is effective during either FWD or REV operation, depending on the set detection level (positive value for FWD operation, negative value for REV operation).

Parmtr Code	Display	Function	Range	Initial Value	V/F Access	Open Loop Vector Access
L4-03	Speed Agree Lvl ±	Speed Agree Level ±	-400.0–150.0 Hz	0.0	Adv	Adv

L4-04 sets the detection width for frequency and desired frequency agree 2 and frequency detection 3 and 4 functions.

Parmtr Code	Display	Function	Range	Initial Value	V/F Access	Open Loop Vector Access
L4-04	Speed Agree Width ±	Speed Agree Width ±	0.0–20.0 Hz	2.0	Adv	Adv

L4-05 selects operation when the frequency reference from the control circuit terminal is reduced by 90% within 400ms.

Parmtr Code	Display	Function	Range	Initial Value	V/F Access	Open Loop Vector Access
L4-05	Ref Loss Sel	Selects operation when the frequency reference of the control terminal is reduced by 90% within 400ms.		0	Adv	Adv
	0 Stop					
	1 Run @ 80% Prev Ref					

Torque Detection

The overtorque detection circuit activates when the motor load causes the motor current to exceed the overtorque detection level (L6-02). When an overtorque condition is detected, alarm signals can be sent to the multi-function output terminals 9, 25 and 26. To output an overtorque detection signal, select torque detection 1 at either of the multi-function contact outputs (H2-XX="B" or "17"). Refer to the H2 section Digital Outputs on page 5-63 for more details.

Parmtr Code	Display	Function	Range	Initial Value	V/F Access	Open Loop Vector Access
L6-01	Torque Det 1 Sel	Activates overtorque detection and selects whether detection generates an alarm or a fault		0	Adv	Adv
	0	Disable				
	1	At Speed Agree-Alarm				
	2	At Run-Alarm				
	3	At Speed Agree-Fault				
	4	At Run-Fault				

Table 5.15

Setting	Description
0	Overtorque detection is disabled (<i>factory default</i>).
1	Overtorque detection is enabled whenever at the speed agree level (when inverter is not accelerating or decelerating). Continue running after detection (OL3 alarm).
2	Overtorque detection is enabled always. Continue running after detection (OL3 alarm).
3	Overtorque detection is enabled whenever at the speed at the speed agree level. Coast to a stop after detection (OL3 fault).
4	Overtorque detection is enabled always. Coast to a stop after detection (OL3 fault).

NOTES:

1. To detect torque during acceleration or deceleration, set to "2" or "4".
2. To continue operation after overtorque detection, set to "1" or "2". During detection, the digital operator displays an "OL3" alarm (blinking).
3. To stop the inverter after an overtorque detection fault, set to "3" or "4". During detection, the digital operator displays an "OL3" fault.

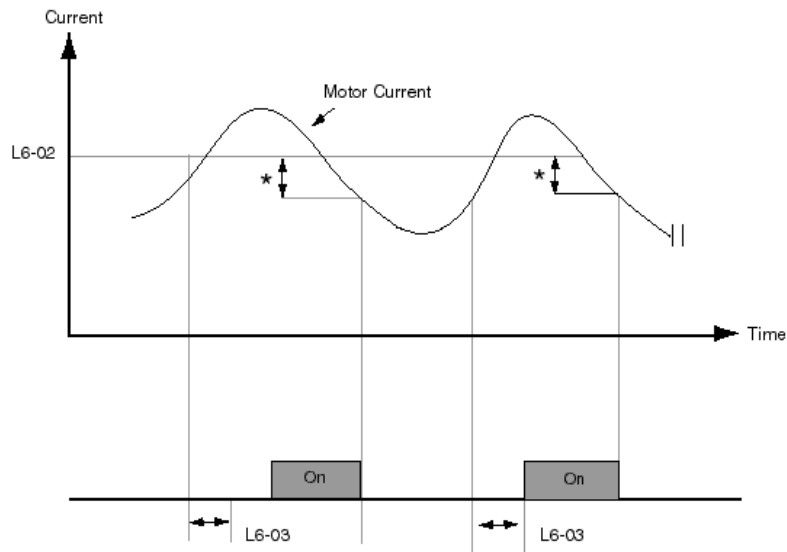

Multi-function Contact Output Signal (Overtorque Detection Signal) Terminal 9, 25, 26

* Release width (hysteresis) during overtorque detection is 5% of the inverter rated current level.

Figure 5-35: Overtorque Characteristics Timing Diagram

Parmtr Code	Display	Function	Range	Initial Value	V/F Access	Open Loop Vector Access
L6-02	Torq Det 1 Lvl	Sets the overtorque detection as a percentage of inverter rated current, during V/f control, and motor rated torque during vector control.	0–300%	150%	Adv	Adv
L6-03	Torq Det 1 Time	The overtorque detection delay time inserts a delay, between the time motor current (or torque) exceeds the overtorque level (L6-02) and when the overtorque detection function is enabled. The digital operator then displays “OL3”.	0.0–10.0 sec	0.1 sec	Adv	Adv

Parmtr Code	Display	Function	Range	Initial Value	V/F Access	Open Loop Vector Access
L6-04	Torq Det 2 Sel	Activates overtorque detection, and selects whether detection generates an alarm or a fault.		0	Adv	Adv

Table 5.16

Setting	Description
0	Overtorque detection is disabled (<i>factory default</i>).
1	Overtorque detection is enabled whenever at the speed agree level (when inverter is not accelerating or decelerating). Continue running after detection (OL4 alarm).
2	Overtorque detection is enabled always. Continue running after detection (OL4 alarm).
3	Overtorque detection is enabled whenever at the speed agree level. Coast to a stop after detection (OL4 fault).
4	Overtorque detection is enabled always. Coast to a stop after detection (OL4 fault).

Overtorque detection 2 functions the same as overtorque detection 1 (L6-01), except that “OL4” is displayed on the digital operator instead. This function is used when two types of detection are output to the multi-function output terminals.

Parmtr Code	Display	Function	Range	Initial Value	V/F Access	Open Loop Vector Access
L6-05	Torq Det 2 Lvl	Torque Detection 2 Level	0–300%	150%	Adv	Adv
L6-06	Torq Det 2 Time	Torque Detection 2 Time	0.0–10.0 sec	0.1 sec	Adv	Adv

Hardware Protection

The IMPULSE•G+ Series 2 comes equipped with a number of built-in functions designed to protect the inverter and its components from damage.

Parmtr Code	Display	Function	Range	Initial Value	V/F Access	Open Loop Vector Access
L8-02	OH Pre-Alarm Lvl	Sets the heatsink temperature level for protection against overheating (OH). Note: The inverter measures heatsink temperature by a negative temperature coefficient thermister.	50–110°C	95°C	Adv	Adv
L8-03	OH Pre-Alarm Sel	Selects the stopping method when heatsink overheating is detected.		3	Adv	Adv
	0 Ramp to Stop	(Decel to stop using B5-02)				
	1 Coast to Stop	(Immediate stop)				
	2 Fast-Stop	(Decel to stop using B5-08)				
	3 Alarm Only	(Operation continues and “OH Heatsink Overtemp” is displayed on keypad)				
L8-10	Ground Fault Detect			1	Adv	Adv
	0 Disabled					
	1 Enabled					
L8-14	UV3 Detect			0	Adv	Adv
	0 Disabled					
	1 Enabled					

Automatic Reset

When a fault occurs (listed in Table 1.1) during operation, the IMPULSE•G+ Series 2 can be programmed for an auto restart operation to automatically reset the fault.

Parmtr Code	Display	Function	Range	Initial Value	Level Access
L9-01	Reset Select 0 Disabled 1 Enabled	Activates the fault auto-reset function.		1	Adv
L9-02	Reset Attempts	Sets the number of reset attempts. Reset attempt counter is returned to zero if no faults occur within a ten minute period.	0–10	3	Adv
L9-03	Reset Time	Sets the reset starting time	0.0–10.0 sec	0.5	Adv
L9-04*	Reset Flt Sel 1	Reset Fault Select 1.	0000–FFFF	1	Adv
L9-05*	Reset Flt Sel 2	Reset Fault Select 2.	0000–FFFF	80	Adv

* To program constant L9-04 and L9-05, refer to the table below and follow steps 1 through 4:

1. Sign 1 to each fault code that you wish to enable the auto reset.
2. Sign 0 to each fault code that you wish to disable the auto reset.
3. Convert all Digits (1 to 4) from binary to hex.
4. Program L9-04 and L9-05 by entering the hex number obtained from step 3.

	Digit 4				Digit 3				Digit 2				Digit 1			
HEX																
Binary	X	X	X	X	X	X	X	X	X	X	X	X	X	X	X	X
L9-04 Menu	D	P	O	R	L	P	O	O	O	S	O	G	O	U	U	U
	E	G	S	H	F	F	L	L	H	C	V	F	C	V	V	V
	V	O					2	1					3	2	1	
L9-05 Menu																
	-	-	-	-	-	-	-	S	C	C	E	E	E	E	E	E
								V	E	A	F	F	F	F	F	F
								E		L	8	7	6	5	4	3
										L						

X=0: Disable

X=1: Enable

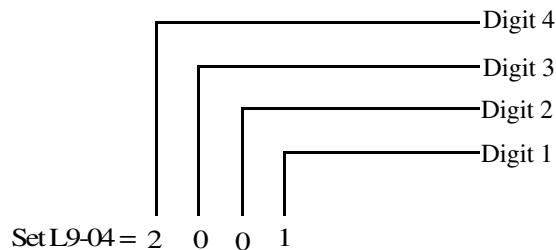

Use the same method to set L9-05 = 0080

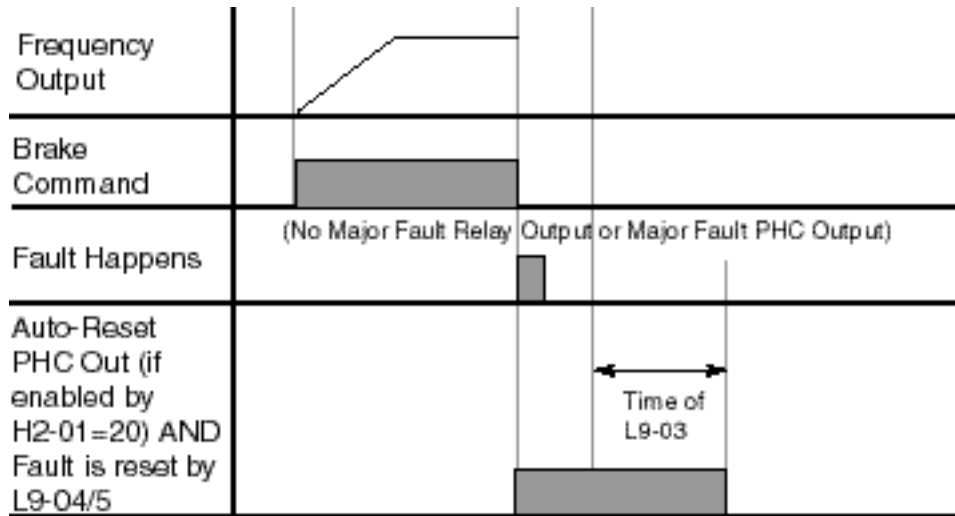

Figure 5-36: Automatic Fault Reset

Example:

Enable auto-reset for UV1, OS and CE faults.

Table 5.18

	Digit 4	Digit 3	Digit 2	Digit 1
HEX	2	0	0	1
Binary	0 0 1 0	0 0 0 0	0 0 0 0	0 0 0 1
L9-04	D P O R E G S H V O	L P O O F F L L 2 1	O S O G H C V F	O U U U C V V V 3 2 1
HEX	0	0	8	0
Binary	0 0 0 0	0 0 0 0	1 0 0 0	0 0 0 0
L9-05	- - - -	- - - S V E	C C E E E A F F L 8 7 L	E E E E F F F F 6 5 4 3

Table 5.19

L9-04	Binary	HEX
Digit 4	0010	2
Digit 3	0000	0
Digit 2	0000	0
Digit 1	0001	1

Table 5.20

Binary Number	Hexadecimal Number
0000	0
0001	1
0010	2
0011	3
0100	4
0101	5
0110	6
0111	7
1000	8
1001	9
1010	A
1011	B
1100	C
1101	D
1110	E
1111	F

Operator Parameters

- O1 Monitor Selection
- O2 Keypad Key Selection
- O3 Clear History

Monitor Selection

The top level in the operation mode allows the viewing of four monitor variables. They are Fref, Fout, Iout, and User-Selected monitor. This user-selected monitor can be selected from the following table. See Monitor Parameters table on page 5-94 for available monitors by control method.

Parmtr Code	Display	Function	Range	Initial Value	V/F Access	Open Loop Vector Access
O1-01	User Monitor Sel	Assigns one of the following monitor parameter as user-selected monitor.	4N35	6	Adv	Adv
	4 Control Method					
	5 Motor Speed	(Open Loop Vector)				
	6 Output Voltage					
	7 DC Bus Voltage					
	8 Output kWatts					
	9 Torque Reference	(Open Loop Vector)				
	10 Input Term Sts					
	11 Output Term Sts					
	12 Int Ctl Sts 1					
	13 Elapsed Time					
	14 FLASH ID					
	15 Term 13 Level					
	16 Term 14 Level					
	17 Term 16 Level					
	18 Mot SEC Current					
	19 Mot EXC Current	(Open Loop Vector)				
	20 SFS Output					
	21 ASR Input	(Open Loop Vector)				
	22 ASR Output	(Open Loop Vector)				
	23 Speed Deviation	(Open Loop Vector)				
	24 PID Feedback					
	25 DI-16 Reference					
	26 Voltage Ref (Vq)	(Open Loop Vector)				
	27 Voltage Ref (Vd)	(Open Loop Vector)				
	28 CPU ID	(Open Loop Vector)				
	29 Load Weight	(Open Loop Vector)				

Parmlr Code	Display	Function	Range	Initial Value	V/F Access	Open Loop Vector Access
	32 <i>ACR(q) Output</i>	(Open Loop Vector)				
	33 <i>ACR(d) Output</i>	(Open Loop Vector)				
	34 <i>OPE Detected</i>					
	35 <i>Friction Torque</i>	(Open Loop Vector)				
O1-02	Power-On Monitor	Selects the monitor to be displayed on the digital operator immediately after the power supply is turned on.		2	Adv	Adv
	1 <i>Frequency Ref</i>	(U1-01)				
	2 <i>Output Freq</i>	(U1-02)				
	3 <i>Output Current</i>	(U1-03)				
	4 <i>User Monitor</i>	(O1-01)				
O1-03	Display Scaling	Units for parameters and monitor related to frequency reference and output frequency can be scaled as shown below.	0–39999	0	Adv	Adv

Table 5.21

Setting (O1-03)	Description
00000	Unit: 0.01Hz (factory default)
00001	Unit: 0.01%
00002 to 00039	Unit: rpm (set O1-03 equal to the number of motor poles)
00040 to 39999 (user-selected units)	Digits: $\frac{5\text{th}}{0}$ $\frac{4\text{th}}{0}$ $\frac{3\text{rd}}{0}$ $\frac{2\text{nd}}{0}$ $\frac{1\text{st}}{0}$ The first thru fourth digits determine the set value at 100% output frequency. Decimal point position is set by the fifth digit as follows: 5th digit = 0: displayed as 0000 5th digit = 1: displayed as 000.0 5th digit = 2: displayed as 00.00 5th digit = 3: displayed as 0.000 Example 1 If 100% output frequency is equal to 200.0 units: Set O1-03="12000"; 100% of this reference is displayed as 200.0 and 60% of this reference is displayed as 120.0. Example 2 If 100% output frequency is equal to 65.00: Set O1-03="26500"; 60% of this reference is displayed as 39.00.

Parmtr Code	Display	Function	Range	Initial Value	V/F Access	Open Loop Vector Access
O1-05	Address Display	Selects how the parameter addresses are displayed on the digital operator.		0	Adv	Adv
	<i>0 Parameter Number</i>					
	<i>1 MEMOBUS Address</i>					

Keypad Key Selection

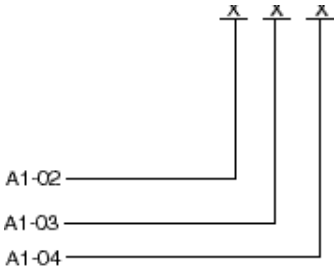
Parmtr Code	Display	Function	Range	Initial Value	V/F Access	Open Loop Vector Access
O2-01	Mode/Service	Enable/disables the digital operator LOCAL/remote key		0	Adv	Adv
	<i>0 Mode/Service</i>	Pressing the Mode/Key once displays "Call ESI Service" 800-288-8178.				
		Pressing the Mode/Key twice displays:				
						
	<i>1 Remote Local</i>	Local/remote key is enabled depressing the local/remote key switches operation command between the digital operator and the settings of B3-01 and B3-02.				
O2-02	Oper Stop Key	Selects the action when the digital stop key is pressed.		0	Adv	Adv
	<i>0 BB, Brake Set</i>	(Immediate stop)				
	<i>1 Decel tim1 Stop</i>	(B5-02)				
	<i>2 Decel tim2 Stop</i>	(B5-04)				
	<i>3 Decel Fault Stop</i>	(B5-08)				
O2-03	User Defaults			0	Adv	Adv
	<i>0 No Change</i>					

	1	<i>Set Defaults</i>	Memorizes up to 50 modified parameters. User defaults can be restored by setting A1 - 05= "1110".		
	2	<i>Clear all</i>	Clear user defaults		
O2-04		kVA Selection	Determines the model number of the drive, which is based on the kVA rating. The following in this column are Electromotive Systems model numbers.	00-FF	Adv Adv
	0	20P4	Not used.		
	1	20P7	2006-AFG+		
	2	21P5	2008-AFG+		
	3	22P2	2011-AFG+		
	4	23P7	2017-AFG+		
	5	25P5	2025-AFG+		
	6	27P5	2033-AFG+		
	7	2011	2054-AFG+		
	8	2015	2068-AFG+		
	9	2018	2080-AFG+		
	A	2022	Not used		
	B	2030	2130-AFG+		
	C	2037	2160-AFG+		
	D	2045	Not used		
	E	2055	2224-AFG+		
	F)	2075	2300-AFG+		
	20	40P4	4001-AFG+		
	21	40P7	4003-AFG+		
	22	41P5	4005-AFG+		
	23	42P2	Not used		
	24	43P7	4008-AFG+		
	25	44P0	4011-AFG+		
	26	45P5	4014-AFG+		
	27	47P5	4021-AFG+		
	28	4011	4028-AFG+		
	29	4015	4034-AFG+		
	2A	4018	4041-AFG+		
	2B	4022	4052-AFG+		
	2C	4030	4065-AFG+		
	2D	4037	4080-AFG+		
	2E	4045	4096-AFG+		
	2F	4055	4128-AFG+		
	30	4075	4165-AFG+		
	31)	4090	Not Used		
	32	4110	4224-AFG+		
	33)	4132	Not Used		
	34	4160	4302-AFG+		

35	4185	Not used			
36	4220	4450-AFG+			
37	4300	4605-AFG+			
42	51P5	5003-AFG+			
43	52P2	5004-AFG+			
44	53P7	5006-AFG+			
45	55P5	5009-AFG+			
46	57P5	5012-AFG+			
47	5011	5017-AFG+			
48	5015	5022-AFG+			
49	5018	5027-AFG+			
4A	5022	5032-AFG+			
4B	5030	5041-AFG+			
4C	5037	5052-AFG+			
4D	5045	5062-AFG+			
4E	5055	5077-AFG+			
4F	5075	5099-AFG+			
50	5090	5130-AFG+			
51	5110	5172-AFG+			
52	5160	5200-AFG+			
O2-05	Up/Down Freq Ref	Selects whether the ENTER key is used when the frequency reference is set by the digital operator. The digital operator can simulate a motor operated potentiometer (M.O.P.) by setting this parameter.	0	Adv	Adv
	0 Disabled	ENTER Key Required			
	1 Enabled	ENTER Key Not Required			
		<i>Note: This feature cannot be used in conjunction with infinitely variable speed control.</i>			
O2-06	Oper Detection	If the digital operator is disconnected from the inverter. This parameter selects whether the inverter detects this condition. The operator is only detected when the inverter is being commanded locally.	0	Adv	Adv
	0 Disabled				
	1 Enabled				
O2-07	Elapsed Time Set	Viewable by U1-13	0-65535	0	Adv Adv
O2-08	Elapsed Time Run	Defines the operation time that accumulates in the timer.		0	Adv Adv
	0 Power-On Time				
	1 Running Time				

Clear History

Parmtr Code	Display	Function	Range	Initial Value	V/F Access	Open Loop Vector Access
O3-01	Clear History 1	Clears fault history.		0	Adv	Adv
	<i>0 Not Clear</i>					
	<i>1 Clear</i>	(U3-01 to U3-08)				
O3-02	Clear History 2	Clears count history.		0	Adv	Adv
	<i>0 Not Clear</i>					
	<i>1 AC Count Clr</i>	Clears AC operations (U3-09).				
	<i>2 OL/LC Count Clr</i>	Clears OL/LC (U3-10).				
	<i>3 Both Count Clr</i>	Both (U3-09 and U3-10).				

Monitor Parameters

Parmtr Code	Display	Function	Units	V/F Access	Open Loop Vector Access
Monitor					
U1-01	Frequency Ref	Frequency Reference	Hz	Operation	Operation
U1-02	Output Frequency	Inverter Output Frequency	Hz	User Program	User Program
U1-03	Output Current	Inverter Output Current	A	User Program	User Program
U1-04	Control Method	Displays the value of A1-02	n/a	User Program	User Program
U1-05	Motor Speed	Motor Speed	Hz	N/A	User Program
U1-06	Output Voltage	Inverter Output Voltage (Reference)	V	User Program	User Program
U1-07	DC Bus Voltage	DC Bus Voltage (Measured)	V	User Program	User Program
U1-08	Output kWatts	Inverter Output Power (Calculated)	kW	User Program	User Program
U1-09	Torque Reference	Torque Reference (Internal)	%	N/A	User Program
U1-10	Input Term Sts	Input Terminal Status (See page 5-96 for a detailed description.)	n/a	User Program	User Program
U1-11	Output Term Sts	Output Terminal Status (See page 5-97 for a detailed description.)	n/a	User Program	User Program
U1-12	Int Ctl Sts 1	Operation Status (See page 5-98 for a detailed description.)	n/a	User Program	User Program
U1-13	Elapsed Time	Elapsed Time. See O2-07 and O2-08.	n/a	User Program	User Program
U1-14	Flash ID	Flash ROM software ID number	n/a	User Program	User Program
U1-15	Terminal 13 Level	External Terminal 13 input level	V	Advanced	Advanced
U1-16	Terminal 14 Level	External Terminal 14 input level	V/mA	Advanced	Advanced
U1-17	Terminal 16 Level	External Terminal 16 input level	V	Advanced	Advanced
U1-18	Mot SEC Current	Motor secondary current (Iq).	A	Advanced	Advanced
U1-19	Mot EXC Current	Motor excitation current (Id).	A	N/A	Advanced
U1-20	SFS Output	Primary freq. after the SFS	Hz	Advanced	Advanced
U1-24	PID Feedback	PID feedback signal level	%	Advanced	Advanced
U1-25	G5IN4 Reference	See page 5-30.	Hex	Advanced	Advanced
U1-26	Voltage Reference (Vq)	Motor secondary voltage reference	V	N/A	Advanced
U1-27	Voltage Reference (Vd)	Motor excitation voltage reference	V	N/A	Advanced
U1-28	CPU ID	CPU software ID number	n/a	Advanced	Advanced
U1-32	ACR (q) Output		%	N/A	Advanced
U1-33	ACR (d) Output		%	N/A	Advanced
U1-34	OPE Detected		const #	Advanced	Advanced
U1-35	Friction Torq		%	Advanced	Advanced

Parmtr Code	Display	Function	Units	V/F Access	Open Loop Vector Access
--------------------	----------------	-----------------	--------------	-------------------	--------------------------------

Fault Trace

U2-01	Current Fault	Displays current fault		User Program	User Program
U2-02	Last Fault	Displays last fault detected	n/a	User Program	User Program
U2-03	Frequency Reference	Freq ref when fault was detected	Hz	User Program	User Program
U2-04	Output Frequency	Output freq when fault was detected	Hz	User Program	User Program
U2-05	Output Current	Output current when fault was detected	A	User Program	User Program
U2-06	Motor Speed	Motor Speed when the “last fault” occurred.		User Program	User Program
U2-07	Output Voltage	Output voltage when fault was detected	V	User Program	User Program
U2-08	DC Bus Voltage	DC Bus voltage when fault was detected	V	User Program	User Program
U2-09	Output kWatts	Output power when fault was detected	kW	User Program	User Program
U2-10	Torque Reference	Torque reference when the “last fault” occurred.		User Program	User Program
U2-11	Input Terminal Sts	Input terminal status when fault was detected	n/a	User Program	User Program
U2-12	Output Terminal Sts	Output terminal status when fault was detected	n/a	User Program	User Program
U2-13	Inverter Status	Inverter status before fault was detected	n/a	User Program	User Program
U2-14	Elapsed Time	Elapsed time when fault was detected	hours	User Program	User Program

Fault History

U3-01	Last Fault	Most recent fault		User Program	User Program
U3-02	Fault Message 2	2nd most recent fault		User Program	User Program
U3-03	Fault Message 3	3rd most recent fault		User Program	User Program
U3-04	Fault Message 4	4th most recent fault		User Program	User Program
U3-05	Elapsed Time 1	Elapsed time of most recent fault		User Program	User Program
U3-06	Elapsed Time 2	Elapsed time of 2nd most recent fault		User Program	User Program
U3-07	Elapsed Time 3	Elapsed time of 3rd most recent fault		User Program	User Program
U3-08	Elapsed Time 4	Elapsed time of 4th most recent fault		User Program	User Program
U3-09	AC Operations	Total number of RUN commands received since the AC counter was last cleared (03-02)		User Program	User Program
U3-10	OL/LC Count	Total number of OL and LC faults detected since the OL/LC counter was last cleared (03-02)		User Program	User Program

U1-10 Input Terminal Status

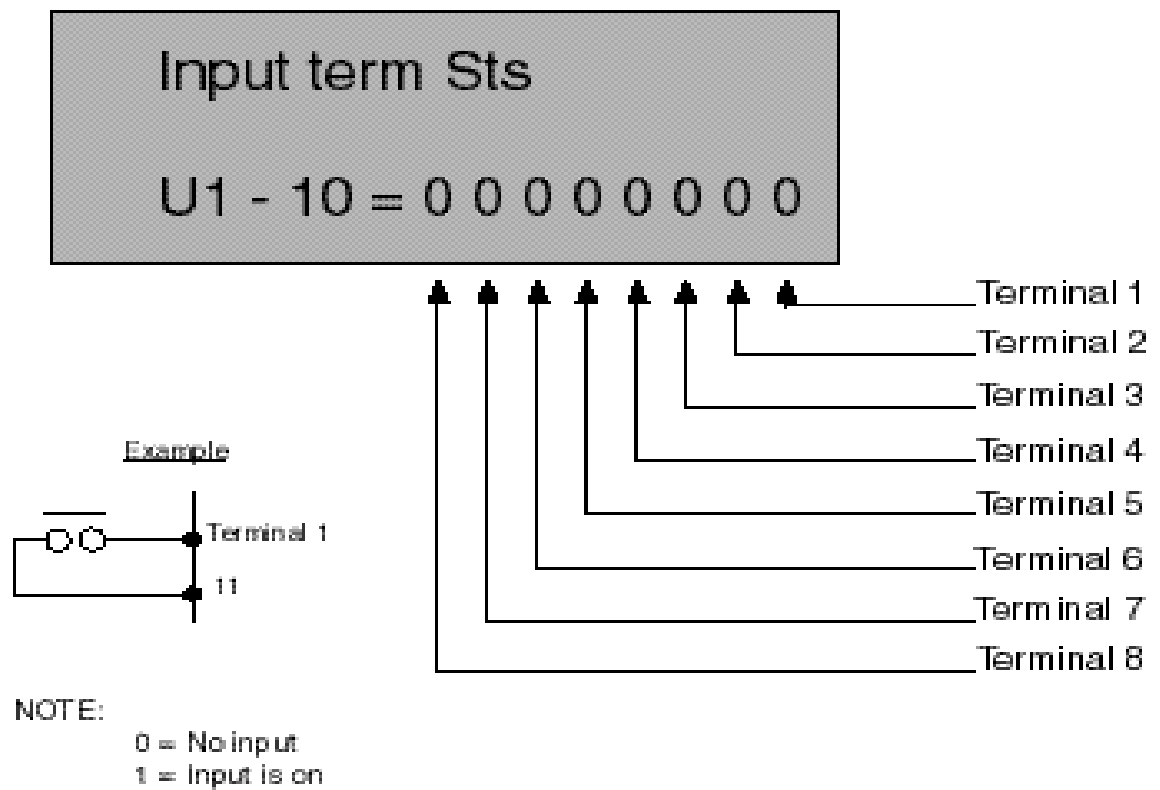

Figure 5-37: Input Terminal Status

U1-11 Output Terminal Status

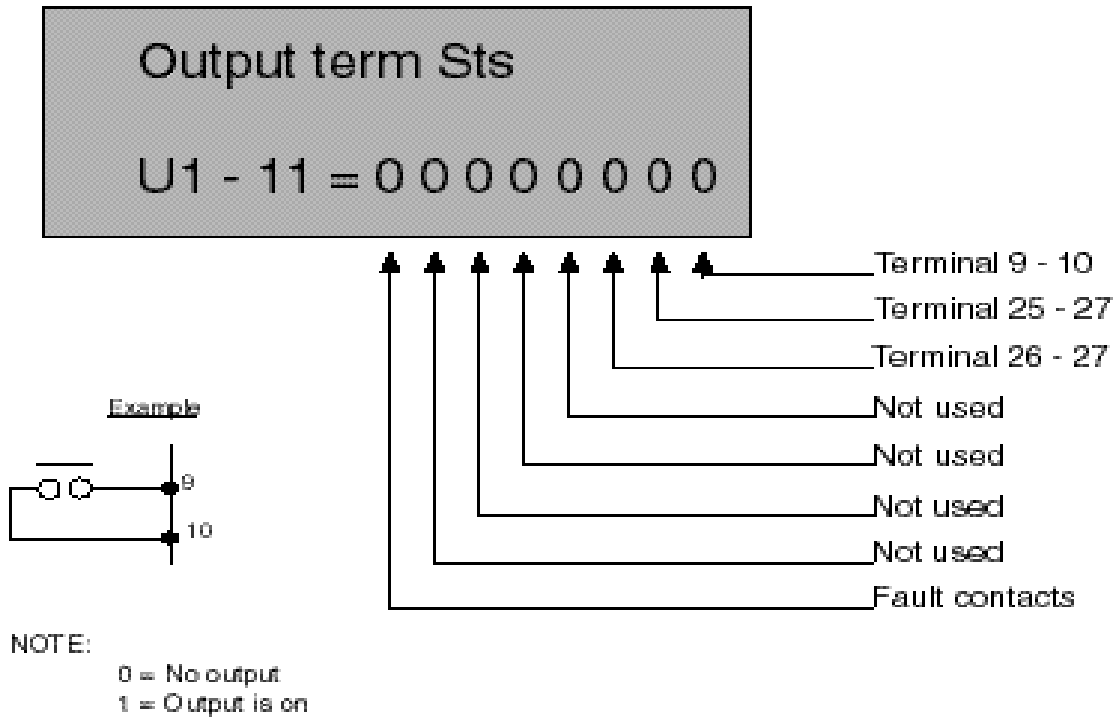

Figure 5-38: Output Terminal Status

U1-12 Inverter Status

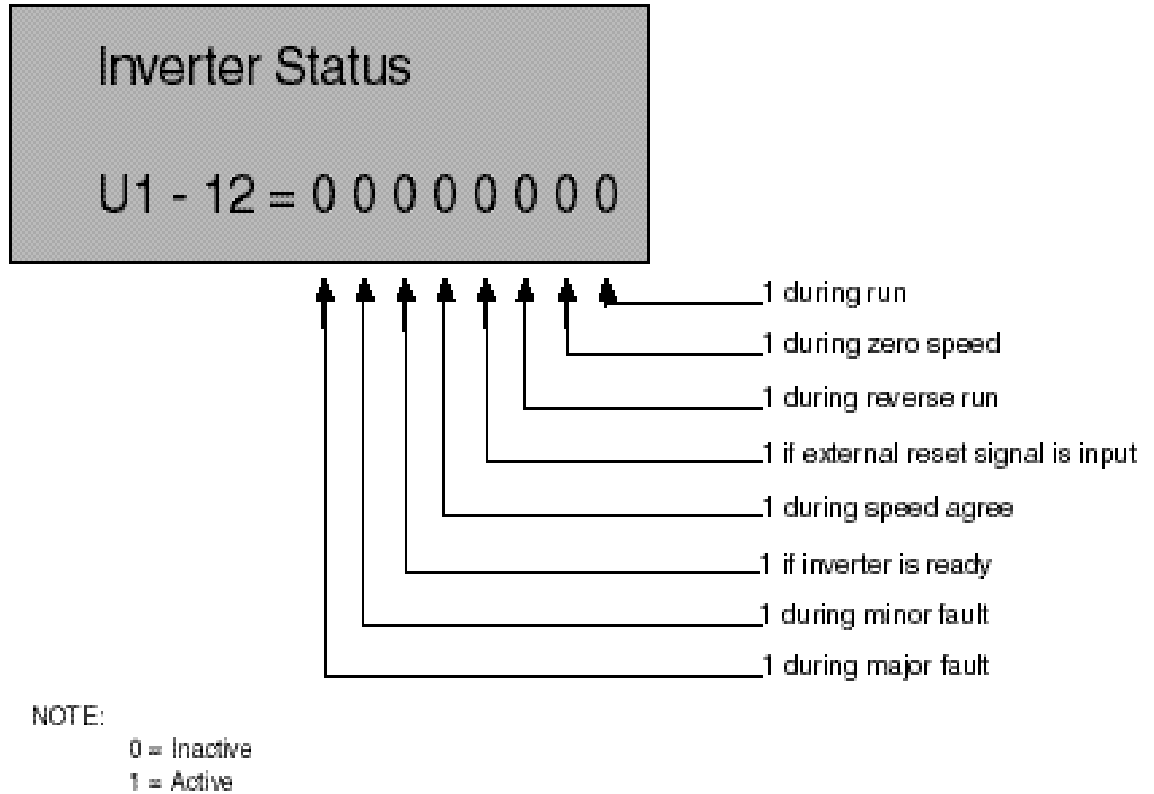

Figure 5-39: Inverter Status

c h a p t e r **6**

**Troubleshooting
IMPULSE•G+ Series 2**

This page intentionally left blank.

Troubleshooting the Drive

In this troubleshooting section, “*check,*” means *investigating whether an item is functioning and in an acceptable physical condition, and then taking corrective action (adjusting, fixing, replacing, etc.) as necessary.* In the Corrective Action column, you may not have to perform all of the steps to correct the problem.

Maintenance and Inspection

This section describes basic maintenance and inspection procedures for the IMPULSE G+ Series 2.

Component	Check	Corrective Action
External terminals, connectors, mounting screws, etc.	Loose screws or connectors	Securely tighten.
Heatsink	Build-up of dust and dirt	Blow with dry, compress air (57-86 psi).
Printed Circuit Board (PCB)	Accumulation of conductive dust or oil	Blow with dry, compress air (57-86 psi). If dust and oil cannot be removed, replace the board.
Cooling Fan	Abnormal noise and vibration	Clean or replace the fan.
Power Components	Accumulation of dust or dirt	Blow with dry, compress air (57-86 psi).

Alarm and Fault classes are described as follows:

- Major Fault: Brake is set, operation indicator lights flash, fault is displayed on keypad and fault contact output (terminals 18, 19 & 20) are activated. The reset key must be pressed, a multi-function input set for fault reset or power must be cycled in order to continue operation.
- Fault (minor): Brake is set, RUN Led flashes until run command is removed, fault is displayed on keypad, fault contact output (terminals 18, 19 & 20) are not activated. The reset key does not need to be pressed. The drive will attempt to run again at the next run command.
- Alarm (Warning): Operation continues, fault is displayed on the keypad, fault contact output (terminals 18, 19 & 20) are not activated.

Motor Faults and Corrective Actions

Symptom	Corrective Action
Analog frequency reference is not stable. (drifting)	<ol style="list-style-type: none"> 1. Stabilize the analog source. 2. Increase B2-02. 3. Increase B5-01, -02.
No motor rotation.	<ol style="list-style-type: none"> 1. Verify that power is on (Charge LED). 2. Verify that the keypad display is not showing a fault. 3. Verify that the run command is input to the drive (U1-10). 4. Motor stalled due to excessive load.
Motor rotation is in the wrong direction.	<ol style="list-style-type: none"> 1. Verify FWD/REV or UP/DN is correct at the interface card. 2. Match wiring to the phase order of the motor leads T1, T2, T3.
Motor rotates, but at minimum speed only.	<ol style="list-style-type: none"> 1. Check wiring of speed inputs. 2. Verify speed reference setting (A1-04). 3. Verify reference and run source settings are correct (B3-01, -02). 4. Verify reference priority setting (B1-10).
Motor RPM too high or too low.	<ol style="list-style-type: none"> 1. Compare motor nameplate specifications with E1 parameter. 2. Check maximum frequency setting (E1-04). 3. Check minimum frequency setting (E1-09).

Drive Faults and Indicators

Fault Code	Fault or Indicator Name/Description	Corrective Action
BB Base Block	External Base Block Indicator. The flashing base block signal is the result of a multi-function input in the terminal strip. The base block indicates that the drive's IGBTs have been disabled. The motor will begin coasting when the base block input is received. If a RUN command is still present when the BB signal is removed, the output voltage will be restored to the previous operating level and operation will continue at the previously commanded frequency.	<ol style="list-style-type: none"> 1. Check constants H1-01 through H1-06 for proper programming. 2. Check terminal status.
BE0 Brake Ans Lost	Brake answer back signal is lost during run. While running, the multi-function input brake answer back is lost.	<ol style="list-style-type: none"> 1. Check brake answer back circuit. 2. Check terminal status. (U1-10)
BE4 Brake Answer 1	Brake Answer-Back Fault Released. At Start, Brake Answer-back is not input within predetermined time (C8-04) after electric brake release command is output—Electric brake not released.	<ol style="list-style-type: none"> 1. Check brake answer back circuit. 2. Increase the value of C8-04. 3. Check terminal status (U1-10).
BE5 Brake Answer 2	Brake Answer-Back Fault Removed. At Stop, Brake Answer-back signal is not removed within predetermined time (C8-11) after electric brake release command is removed—Electric brake not closed.	<ol style="list-style-type: none"> 1. Check brake answer back circuitries. 2. Increase the value of C8-11 time. Note: A1-02 must = 2 OLV
CALL Serial Com Call	Serial Communication SI-B Transmission Fault. Control data is not received correctly after power supply is turned ON for 2 sec.	<ol style="list-style-type: none"> 1. Check serial device connections. 2. Ensure drive is properly programmed for serial communication.

Fault Code	Fault or Indicator Name/Description	Corrective Action
CE Memobus Com Err	Communication Error. Serial communications disruption.	<ol style="list-style-type: none"> 1. Check serial connections (6 CN). 2. Check H5-01 through H5-05 for proper programming.
CF Out of Control	Out of Control. Occurs in OLV only. During deceleration, the motor torque exceeds the regenerative torque limit setting for more than 3 seconds.	<ol style="list-style-type: none"> 1. Evaluate application. 2. Check regenerative torque limit setting (C7-03, C7-04) 3. Check the stopping method, (B3-03) and the deceleration times (B5-02, B5-04)
CPF00 Com-Err (OP&INV)	Control Circuit Fault 1— Keypad Transmission. Because of external noise, excessive vibration or shock, or component failure (including RAM and PROM), one or both of the following occurs: <ul style="list-style-type: none"> • Transmission between the inverter and keypad cannot be established 5 sec after power-up. • MPU peripheral element check fault (on-line). 	<ol style="list-style-type: none"> 1. Check the keypad connection. 2. Check the control circuit wiring. 3. Replace keyboard. 4. Replace Control board.
CPF01 Com-Err (OP&INV)	Control Circuit Fault 2—Keypad Transmission. After initial power-up, communication between the inverter and keypad was interrupted for more than 2 seconds.	<ol style="list-style-type: none"> 1. Check keypad connection. 2. Cycle Power 3. Replace keypad 4. Replace Control board.
CPF02 BB Circuit Err	Base Block Circuit Fault. Base block circuit fault at power-up.	<ol style="list-style-type: none"> 1. Cycle power. 2. Ensure that the control board terminals are shielded from electrical noise. 3. Replace Control board.
CPF03 EEPROM Err	EEPROM Fault. Invalid data found in the EEPROM.	<ol style="list-style-type: none"> 1. Cycle power. 2. Ensure that the control board terminals are shielded from electrical noise. 3. Replace Control board.
CPF04 Internal A/D Err	Internal A/D Converter Fault. CPU internal analog-digital converter fault.	<ol style="list-style-type: none"> 1. Cycle power. 2. Ensure that the control board terminals are shielded from electrical noise. 3. Replace Control board.
CPF05 External A/D Err	External A/D Converter Fault. CPU external analog-digital converter fault.	<ol style="list-style-type: none"> 1. Cycle power. 2. Ensure that the control board terminals are shielded from electrical noise. 3. Replace Control board.
CPF06 Option Error	Option Card Fault. Optional card has disconnected or failed.	<ol style="list-style-type: none"> 1. Power down. 2. Verify proper installation of all option cards.
CPF10	Control Circuit Fault 10 — G5IN4. G5IN4 option card failure.	<ol style="list-style-type: none"> 1. Power down. 2. Verify proper installation of G5IN4. 3. Replace G5IN4 card.
CPF20 Option A/D Error	Control Circuit Fault 20 — AI-14. Analog-to-digital converter fails or analog speed reference error.	<ol style="list-style-type: none"> 1. Power down. 2. Verify proper installation of AI-14B. 3. Replace AI-14B card.

Fault Code	Fault or Indicator Name/Description	Corrective Action
CPF21 Option CPU Down	Control Circuit Fault 21 — CPU on Optional Card. CPU on an installed optional card fails.	<ol style="list-style-type: none"> 1. Power down. 2. Verify proper installation of option card. 3. Replace card.
CPF22 Option Type Err	Control Circuit Fault 22 — Optional Card Code. Optional card code is not compatible with the inverter.	<ol style="list-style-type: none"> 1. Power down. 2. Verify proper card. 3. Verify proper installation of option card. 4. Replace card.
CPF23 Option DPRAM Err	Control Circuit Fault 23 — DP-RAM. DP-RAM on an installed optional card failed.	<ol style="list-style-type: none"> 1. Power down. 2. Remove any inputs to card. 3. Verify proper installation of option card. 4. Replace card.
EF (Blinks) External Fault	Both FORWARD/UP and REVERSE/DOWN commands are input at same time for 500 msec or longer.	<ol style="list-style-type: none"> 1. Check control input circuitries. 2. Check the sequence of operation.
EF3 External Fault 3	External fault occurs in the Terminal 3 external control circuit.	<ol style="list-style-type: none"> 1. Check constant H1-01 for proper programming. 2. Check the condition of the input terminal #3 on G5IF card.
EF4 External Fault 4	External fault occurs in the Terminal 4 external control circuit.	<ol style="list-style-type: none"> 1. Check constant H1-02 for proper programming. 2. Check the condition of the input terminal #4 on G5IF card.
EF5 External Fault 5	External fault occurs in the Terminal 5 external control circuit.	<ol style="list-style-type: none"> 1. Check constant H1-03 for proper programming. 2. Check the condition of the input terminal #5 on G5IF card.
EF6 External Fault 6	External fault occurs in the Terminal 6 external control circuit.	<ol style="list-style-type: none"> 1. Check constant H1-04 for proper programming. 2. Check the condition of the input terminal #6 on G5IF card.
EF7 External Fault 7	External fault occurs in the Terminal 7 external control circuit.	<ol style="list-style-type: none"> 1. Check constant H1-05 for proper programming. 2. Check the condition of the input terminal #7 on G5IF card.
EF8 External Fault 8	External fault occurs in the Terminal 8 external control circuit.	<ol style="list-style-type: none"> 1. Check constant H1-06 for proper programming. 2. Check the condition of the input terminal #8 on G5IF card.
ERR EEPROM R/W Err	EEPROM Read/Write Fault. EEPROM internal data did not match when initializing the parameter.	<ol style="list-style-type: none"> 1. Cycle Power. 2. User initialize (A1-05=1110). 3. Replace Control board.
FAN Fan Fault	Cooling fan fails while power is on.	<ol style="list-style-type: none"> 1. Remove any debris from fan. 2. Check fan wiring. 3. Replace fan (contact Electromotive Systems).

Fault Code	Fault or Indicator Name/Description	Corrective Action
GF Ground Fault	During operation, the inverter sums the currents of all three motor phases. Ideally, the sum should always equal zero. If the sum is greater than 50% of the inverter rated output current, a GF occurs.	<ol style="list-style-type: none"> 1. Disconnect motor from drive and check it for shorts using a megger. 2. Ensure that R/C Surge Suppressors are used across all brake contactor coils to prevent disturbance by electrical transients. 3. With Output Phase Loss disabled (B6-03), verify drive operation with motor disconnected.
LCI Load Check Err	Load Check Fault. Load is greater than specified amount.	<ol style="list-style-type: none"> 1. Reduce Load. 2. Check Load Check sequence set-up. (C5-XX).
LF Output Pha Loss	An open phase occurred at the inverter output.	<ol style="list-style-type: none"> 1. Check for broken wires in output cable. 2. Check for open winding in the motor. 3. Check for loose terminals 4. With Output Phase Loss disabled, verify drive operation with motor disconnected.
LL1 Lower Limit 1 Err	Lower Limit 1—SLOW DOWN Indicator. Lower Limit 1—SLOW DOWN is input (switch status is changed).	<ol style="list-style-type: none"> 1. May not require corrective action. 2. Check the Limit Switches position. 3. Check the Limit Switches condition.
LL2 Lower Limit 2 Err	Lower Limit 2—STOP Indicator. Lower Limit 2—STOP is input (switch status is changed).	<ol style="list-style-type: none"> 1. May not require corrective action. 2. Check the Limit Switches position. 3. Check the Limit Switches condition.
OC Over Current	Output current exceeds 200% of inverter rated output current.	<ol style="list-style-type: none"> 1. Check for a phase-to-phase short in the motor or wiring using a megger. 2. Extend the acceleration/deceleration time.
OH (blinking) Heatsnk Over temp	Overheat Pre-Alarm. Cooling fan is overheating. The temperature of the inverters cooling fans exceeded the setting in L8-02.	<ol style="list-style-type: none"> 1. The inverter cooling fan has stopped. 2. Reduce the ambient temperature.
OHI Heatsink MaxTemp	Overheat Fault. There are two situations that result in an overheat fault. The first occurs when the measured heat sink exceeded 105°C. The second is a result of a fault in the internal 24VDC cooling fan.	<ol style="list-style-type: none"> 1. Ensure that the heat sink cooling fans are functioning. 2. Ensure that the heat sink is free from dirt and debris. 3. Ensure that the inverter's ambient temperature is within specification. 4. Replace the 24VDC fan 5. Replace the heat sink thermistor(s)
OL1 Motor Overloaded	Motor Overload Fault. Inverter output exceeded the motor overload level.	<ol style="list-style-type: none"> 1. Ensure drive is programmed with proper motor full load Amp (E2-01). 2. Reduce the load.
OL2 INV Overloaded	Inverter Overload Fault. Inverter output exceeded the inverter overload level.	<ol style="list-style-type: none"> 1. Reduce the load. 2. Extend the acceleration time.
OL3 Overtorque Det 1	Overtorque Detection Level 1 Fault. Defined by L6-02. Alarm defined by L6-01.	<ol style="list-style-type: none"> 1. Check for proper programming for L6-XX constant.
OL4 Overtorque Det 2	Overtorque Detection Level 2 Fault. Defined by L6-05. Alarm defined by L6-04.	<ol style="list-style-type: none"> 1. .Check for proper programming for L6-XX constant.

Fault Code	Fault or Indicator Name/Description	Corrective Action
OP	Keypad Digital Monitor Fault. Digital monitor unit in keypad fails, or the keypad is mounted when in the program mode or during operation by the operator.	1. Remove power and remount keypad.
OP3	Optional Card Fault. Optional card is incompatible or has failed.	1. Replace optional card.
OPE01 kVA Selection	kVA Setting Fault. Inverter kVA setting range is incorrect.	1. Check 02-04 constant for proper kVA.
OPE02 Limit	Setting Out of Range . Parameter setting is out of range.	<ol style="list-style-type: none"> 1. With the fault displayed on the keypad, press the DATA/ENTER key to reveal the “Out of Range” parameter via the U1-34 monitor. 2. Verify that E2-03 is < E2-01. 3. Verify E1-05 is within range. 4. Compare Modified constants with defaults. 5. Cycle Power.
OPE03 Terminal	Multi-Function Input Setting Fault. Set values other than “F” and “FF” are duplicated.	1. Check the settings for H1-01 to H1-06, verify that the same input is not used twice.
OPE05 Sequence Select	Sequence Select Setting Fault. B3-01 and B3-02 and no option is plugged in.	1. Check the function selection or plug in optional card.
OPE07 Analog Selection	Multi-Function Analog Input Setting Fault. H3-05 and H3-09 multi-Function analog input settings are set to the same value.	1. Check the function selections.
OPE10 V/F PTRN Setting	V/f Data Setting Fault. V/f data is set such that the following equation is not satisfied: $E1-09 \leq E1-07 \leq E1-06 \leq E1-11$ (If not =0) $\leq E1-04$.	1. Check the parameter data settings.
OPE11 CarrFrq/ON-Delay	Carrier Frequency Setting Fault. Occurs when one of the following occurs: <ul style="list-style-type: none"> • Carrier Frequency upper limit (D10-01) > 5 kHz and carrier frequency low limit (D10-02) \leq 5 kHz. • Carrier frequency proportional gain (D10-03) > 6 and (D10-01) δ (D10-02). 	1. Check the parameter data settings.
OPR Oper Disconnect	Keypad Disconnected. The keypad is removed while the inverter is running, and the run command was initiated via the keypad RUN key.	<ol style="list-style-type: none"> 1. Secure the keypad. 2. Verify O2-06 setting.
OV DC Bus Overvolt	Overvoltage Fault. The main circuit direct current voltage exceeded the overvoltage level. Detection level: 230V class—approx. 400V 460V class—approx. 800V 575V class—approx. 1000V	<ol style="list-style-type: none"> 1. Extend the deceleration time. 2. Check for proper DBU operation. 3. Check the resistor. 4. Check the line voltage.
OV (blinks) DC Bus Overvolt	Overvoltage Fault. Overvoltage occurs during stop. Main circuit DC voltage rises above the detection level while the drive output is off. Detection level: 410V or more for 230V, 820V or more for 460V and 1040V or more for 575V.	1. Check the line voltage.
PF Input Pha Loss	Input Phase Loss Fault. Inverter input power supply has open phase.	<ol style="list-style-type: none"> 1. Check the line voltage. 2. Remove power. 3. Retighten the input terminal screws.

Fault Code	Fault or Indicator Name/Description	Corrective Action
PUF DC Bus Fuse Open	DC Bus Fuse Open Fault. The DC fuse is open.	<ol style="list-style-type: none"> 1. Check for damaged transistor. 2. Check load-side short circuit. 3. Check grounding. <p><i>Do not replace an open DC bus fuse until the cause of failure has been corrected; non-warranty, damage to the drive may result. Refer to page 3-12.</i></p>
RH DynBrk Resistor	Braking Resistor Overheat Fault. The factory installed, 3% dynamic braking resistor has exceeded an allowable temperature. This does not apply to ESI external braking resistors.	<ol style="list-style-type: none"> 1. Check the L8-01 setting. Only select “provided” when using the factory installed 3% resistor. 2. Ensure that the braking duty cycle is not greater than 3% of the operation time.
RR DynBrk Transistr	Braking Transistor Fault. Internal Braking transistor failed.	<ol style="list-style-type: none"> 1. Verify that the external braking resistor is connected to the proper terminals. 2. Confirm that the proper resistor is installed. 3. Check for a short circuit across the braking resistor.
SC Short Circuit	Short Circuit Fault. The inverter has detected an output short circuit condition.	<ol style="list-style-type: none"> 1. Disconnect the motor from the inverter. 2. Check for a short circuit in the motor or wiring using a megger.
THM	Thermistor Fault. Thermistor is not connected, or thermistor connection is faulty.	Reconnect or replace thermistor.
UL1 Upper Limit 1 Err	Upper Limit 1—SLOW DOWN Indicator. Upper Limit 1—SLOW DOWN switch status is changed.	<ol style="list-style-type: none"> 1. May not require corrective action. 2. Check the limit switches location. 3. Check the limit switches condition.
UL2 Upper Limit 2 Err	Upper Limit 2—STOP Indicator. Upper Limit 2—STOP switch status is changed.	<ol style="list-style-type: none"> 1. May not require corrective action. 2. Check the limit switches location. 3. Check the limit switches condition.
UV DC Bus Undervolt	Undervoltage Fault. Undervoltage status occurs for more than 2 sec during STOP. Input voltage drops below 190V DC or less for 230V AC class, 380V DC or less for 460V AC class and 546V DC or less for 575V AC class.	<ol style="list-style-type: none"> 1. Check the power source wiring. 2. Replace any bad branch fuses. 3. Check collector system.
UV1 DC Bus Undervolt	Undervoltage 1 Fault. Undervoltage status occurs for more than 2 sec during RUN command. Input voltage drops below 190V DC or less for 230V AC class, 380V DC or less for 460V AC class and 546V DC or less for 575V AC class.	<ol style="list-style-type: none"> 1. Check power supply wiring. 2. Correct the line voltage. 3. Check collector system.
UV2 CTL PS Undervolt	Undervoltage 2 Fault. The inverter detected a loss of the 24V logic power supply voltage. This fault is only detected in inverters rated 2130-AFG+ through 2300-AFG+, 4128-AFG+ through 4605-AFG+ and 5027-AFG+ through 5200-AFG+.	<ol style="list-style-type: none"> 1. Check power supply wiring. 2. Correct the line voltage. 3. Check collector system.
UV3 MC Answerback	MC Fault. The pre-charge contactor opened during operation.	<ol style="list-style-type: none"> 1. Check power supply wiring. 2. Correct the line voltage. 3. Check collector system.

Fault Display and Corrective Actions at Auto-tuning

(Open Loop Vector)

Fault Display	Fault or Indicator Name/Description	Corrective Action
Data Invalid (Motor data fault)	Motor data fault. Invalid motor data.	<ul style="list-style-type: none"> • Verify input data. • Verify motor/drive capacities. • Change the settings to conform to the following equation: Rated speed < 120 x Motor frequency/ number of poles
Resistance (Line-to-line resistance fault)	Terminal resistance fault. Tuning was not completed within the specified time.	
No-Load Current	No-Load Current fault. Tuning was not completed within the specified time.	
Saturation-1	Iron core saturation coefficient 1 fault. The core saturation coefficient was not completed within the specified time.	<ul style="list-style-type: none"> • Incorrect rated current setting • Check for loose/broken or disconnected motor wire
Saturation-2	Iron core saturation coefficient 2 fault. the core saturation coefficient was not completed within the specified time.	
Rated Slip	Rated Slip Fault. Rated slip setting was not completed within the specified time.	<ul style="list-style-type: none"> • Verify that the motor is de-coupled from load.
Accelerate	Acceleration fault. Motor does not accelerate in specified time.	<ul style="list-style-type: none"> • Verify the brake is released (manually). • Increase acceleration time (B5-01). • Verify that the motor is de-coupled from load. • Verify that C7-01, -02 = 150%.
Motor Speed	Motor Speed Fault. Torque reference becomes excessive (100%) during tuning.	<ul style="list-style-type: none"> • Verify that the brake is released (manually). • Increase acceleration time B5-01. • Verify that the motor is de-coupled from load.
Alarm: Overload (Displayed after completion of turning)	Excessive tuning load. Torque reference exceeded 20% at tuning	<ul style="list-style-type: none"> • Verify that the motor is de-coupled from load. • Turn the power off and rotate the motor shaft by hand. Replace motor if it does not turn smoothly.

Troubleshooting CDBR Faults

Fault Status	Possible Cause	Corrective Action
Drive trips at overvoltage (OV)	<ul style="list-style-type: none"> • Insufficient braking unit capacity • Insufficient resistor capacity • Improper wiring • Deceleration time too short • Braking unit fault 	<ol style="list-style-type: none"> 1. Verify CDBR capacity 2. Verify resistor capacity 3. Verify wiring is correct 4. Lengthen deceleration time 5. Replace the braking unit
Braking Unit Thermal Overload trips when not decelerating	<ul style="list-style-type: none"> • Improper braking unit power supply voltage selection setting • Incoming (line) voltage too high • Discharge transistor shorted 	<ol style="list-style-type: none"> 1. Verify Jumper setting 2. Correct Line Voltage 3. Replace the braking unit
Braking Unit trips by heatsink overheat	<ul style="list-style-type: none"> • Excessive load inertia • Improper combination of braking unit and resistor • Ambient temperature > 113°F 	<ol style="list-style-type: none"> 1. Reduce load 2. Verify proper braking unit/resistor 3. Install air conditioner

Power Section Check



WARNING

Do NOT touch any circuit components while AC main power is on or immediately after the main AC power is disconnected from the unit. You must wait until the red “CHARGE” lamp is extinguished. It may take as long as 10 minutes for the charge on the main DC bus capacitors to drop to a safe level. Failure to adhere to this warning could result in serious injury.

Power Off Checks

To perform a power section check, remove the drives main and control wiring from the terminal strips. Obtain reading as specified in the table on the following page and ensure that the reading falls within the normal reading range.

Test equipment - Analog Ohmmeter set R x 1 scale or digital multimeter set to the diode check.

Device	VOM (on RX1 Scale)		Normal Reading (Analog Meter)	Normal Reading (Digital Meter)
	Positive Lead	Negative Lead		
Input Rectifier Bridge *1	L1	+	7-100Ω	Approximately 0.5 V
	L2	+		
	L3	+		
	-	L1		
	-	L2		
	-	L3		
	L1	-	Infinite Ω	OL Displayed
	L2	-		
	L3	-		
	+	L1		
	+	L2		
	+	L3		
Bus Capacitors	+	-	Observe gradually increasing resistance	Observe gradually increasing voltage to OL
Pre-charge Resistor	-	Across the Resistors	100 Ω or less	-
Output Transistors *2 *3	T1	+	7-100 Ω	Approximately 0.5V
	T2	+		
	T3	+		
	-	T1		
	-	T2		
	-	T3		
	T1	-	Infinite Ω	OL Displayed
	T2	-		
	T3	-		
	+	T1		
	+	T2		
	+	T3		
Braking Diode (2006-2033) (4001-4034)	B2	B1	10 Ω	0.5 V
	B1	B2	Infinite Ω	OL Displayed

*1. “+” could be any one of three (+) terminals which are labeled as ⊕1, ⊕2, and ⊕3.

*2. If the bus fuse is blown you must install a jumper across the fuse terminals to get accurate resistance measurements.

*3. If the pre-charge resistor is open, you will read infinite Ω between + and any output terminal unless you install a temporary jumper across the resistor.

Braking Circuit

Test Equipment - Analog Ohmmeter set to R X 1 scale or digital multimeter set to the diode check.

Step No.	Ohmmeter Positive Lead	Ohmmeter Negative Lead	Expected Reading (Analog Meter)	Expected Reading (Digital Meter)
1	Connect to B2	Connect to B1	10 Ohms	0.5 Volts
2	Connect to B1	Connect to B2	Infinite Ohms	0L displayed

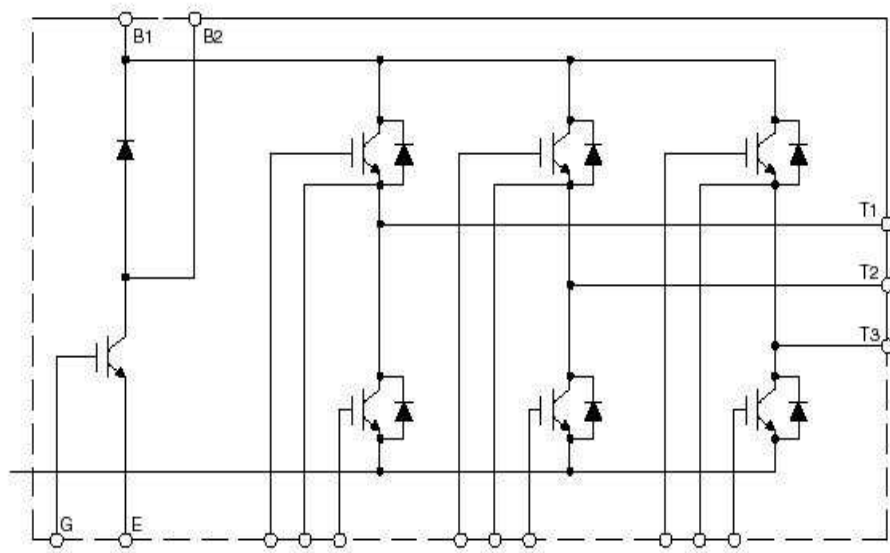

Figure 6-1

A p p e n d i x **A**

Servicing
IMPULSE•G+ Series 2

This page intentionally left blank.

Service

This chapter includes information pertaining to on-call service, drive identification, troubleshooting, and warranty. Before you install, troubleshoot, or service the drive, we highly recommend that you read this entire chapter. Doing this will help assure quick service response, minimize your on-site repair costs, and reduce crane downtime.

Your *IMPULSE•G+* Series 2 drive includes a two-year warranty from date of shipment. The warranty is described in detail later in this chapter.

On-Call Service

If you ever require our assistance, contact us at (800) 288-8178; our fax number is (800) 298-3508. Technical support is available 24 hours a day, seven days a week, and 365 days a year. If necessary, we can arrange to have a Service Technician visit your site to evaluate the situation.

Identifying Your Drive

If you ever have to contact Electromotive Systems about your drive, first determine the model and serial numbers of your drive by looking at the nameplate shown below.

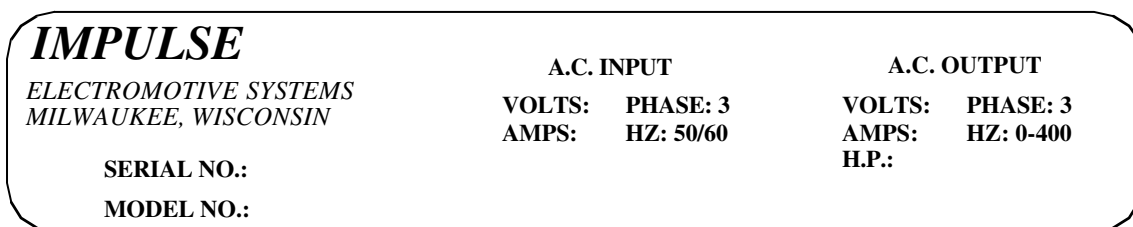

Figure 6.1

This nameplate is normally located on the side of the drive nearest to the keypad.

Service Policy For Small Drives, DBUs, and Other Electrical Components

This section explains Electromotive Systems' service policy for the small drives (2006-AFG+ through 2224-AFG+ and 4001-AFG+ through 4165-AFG+ and 5003-AFG+ through 5099-AFG+), dynamic braking units (DBUs), and other electrical components.

Should your *IMPULSE* product fail during the warranty period, Electromotive Systems will repair or replace your unit within 72 hours (3 working days). In most cases, we can supply a replacement unit within 24 hours (1 working day). If the problem is not covered under warranty, you are responsible for the cost of the repairs and the shipping charges.

To return a failed unit (or part):

1. Request a Return Authorization (RA) from Electromotive Systems' Service Department, as a condition for us to repair or replace the unit. Return the failed unit to Electromotive Systems **via pre-paid freight**. When you call, please have the serial number of the drive available and be prepared to provide the information requested on the Return Authorization Information Sheet found on page A-5.
2. A purchase order or credit card is required to cover the cost of the replacement unit or repairs to a returned unit.

Electromotive Systems will inspect the failed unit and determine if the unit is covered under warranty.

- If the unit is covered under warranty, Electromotive Systems will credit the cost of the replacement unit and/or repairs and reimburse for all reasonable freight charges.

NOTE: Freight charges incurred from sources other than common ground carriers WILL NOT be reimbursed unless pre-approved by Electromotive Systems.

- If the unit is not covered under warranty, Electromotive Systems will bill you for the cost of the replacement unit or the cost of repairs. Electromotive Systems will also bill you for a \$125.00 inspection fee (this fee will be waived if repairs are made to the unit) and any freight charges incurred by Electromotive Systems.

Service Policy for Large Drives

This section explains Electromotive Systems' service policy for the large drive (2300-AFG+, and 4224-AFG+ through 4605-AFG+, and 5130-AFG+ through 5200-AFG+).

Because of the size and weight of large units, it may not be practical to return the entire drive to Electromotive Systems for repair. If a drive has failed, you must first contact us by telephone for assistance in diagnosis. If necessary, we may authorize the on-site replacement of specific components and the return of these failed parts for credit, replacement, or repair.

These components include; but not limited to:

- Control/logic card
- Main base drive card
- Subbase drive card
- Drive unit transistor cassette
- Fan unit
- Main input diode circuit
- Capacitors
- DC Bus Fuses
- Electromotive Systems interface and special option cards.

On-site troubleshooting and the replacement of failed components is to be performed only by technicians approved by Electromotive Systems.

Follow procedures outlined above for returning components.

SAMPLE

Electromotive Systems Limited Warranty

Electromotive Systems, hereafter referred to as Company, guarantees all items manufactured by it against any defects of material and/or workmanship for a period of two years from the date of shipment. Company makes NO OTHER WARRANTY, EXPRESSED OR IMPLIED, AS TO THE MERCHANTABILITY OR FITNESS OF THE ITEMS FOR THEIR INTENDED USE OR AS TO THEIR PERFORMANCE. Any statement, description or specification in Company's literature is for the sole purpose of identification of items sold by the Company and imparts no guarantee, warranty or undertaking by company of any kind. Components and accessories not manufactured by Electromotive Systems are not included in this warranty and are warranted separately by their respective manufacturers.

Company's sole liability shall be to repair at its factory, or replace any item returned to it within two years from date of shipment, which Company finds to contain defective material or workmanship. All items to be repaired or replaced shall be shipped to Company (Note: return authorization by Company is required) within said two year period, freight prepaid, as a condition to repair or replace defective material or workmanship. Company's herein assumed responsibility does not cover defects resulting from improper installation, maintenance, or improper use. Any corrective maintenance performed by anyone other than the Company during the warranty period shall void the warranty. Company shall not be liable for damages of any kind from any cause whatsoever beyond the price of the defective Company supplied items involved. Company shall not be liable for economic loss, property damage, or other consequential damages or physical injury sustained by the purchaser or by any third party as a result of the use of any Company supplied items or material.

Company neither assumes nor authorizes any other person to assume for Company any other liability in connection with the sale or use of items sold by Company.

Materials or items may not be returned for credit, without the prior written consent of the Company. Any authorized return of materials or items shall be subject to a restocking charge equal to 25% of the net invoiced amount (\$100 minimum charge for all control products) after Company determines that the material or item is in resalable condition. If upon receipt of the material or items returned, the Company determines that said material or items cannot be resold without alteration or service, the Company reserves the right to reject the returned materials or items and to send the same back to said purchaser at purchaser's expense.

Any claim for errors in shipment or for material or time shortages must be received by Company within 30 days of shipment and must be accompanied by copies of the bill of lading and packing slip.

IMPULSE•G+ Series 2 Parameter Listing

No.	Parameter Name	Initial Value	Ref Page#
A1-01	Access Level	2	4-9
A1-02	Control Method	0 or 2	4-9
A1-03	Motion	0 or 1	4-10
A1-04	Speed Ref	6	4-10
A1-05	Init Parameters	0	4-14
A1-06	Password 1	0	4-14
A1-07	Select Password 1	0	4-14
A2-01 to A2-30	User Parameters	—	4-14
B1-01	Reference 1	15.00	5-3
B1-02	Reference 2	30.00	5-3
B1-03	Reference 3	60.00	5-3
B1-04	Reference 4	45.00	5-3
B1-05	Reference 5	60.00	5-3
B1-06	Reference 6	0.0	5-3
B1-07	Reference 7	0.0	5-3
B1-08	Reference 8	0.0	5-3
B1-09	Jog Reference	6.00	5-3
B1-10	Ref Priority	0	5-3
B2-01	Ref Upper Limit	100.0	5-5
B2-02	Ref Lower Limit	2.0	5-5
B2-03	Upper Limit Gain	100	5-5
B3-01	Reference Source	1	5-6
B3-02	Run Source	1	5-6
B3-03	Stopping Method	0 or 1	5-7
B3-06	Control Input Scans	1	5-12
B3-07	Local/Remote Run Select	0	5-12
B4-02	Trim Control Level	10	5-13
B5-01	Acceleration Time 1	5.0	5-14
B5-02	Deceleration Time 1	3.0	5-14
B5-03	Acceleration Time 2	1.0	5-14
B5-04	Deceleration Time 2	1.0	5-14
B5-05	Acceleration Time	1.0	5-15
B5-06	Deceleration Time N Change	1.0	5-15
B5-07	Hoist 2 Stop Decel	0.3	5-15
B5-08	Fault Stop Time	0.3	5-15
B5-09	Accel/Decel Units	1	5-15
B5-10	Accel/Decel Switch Freq	120.0	5-15
B5-11	Switch Freq Compare	1	5-15
B5-12	Forward Torque Limit Accel	0.0	5-16
B5-13	Forward Torque Limit Decel	0.0	5-16
B5-14	Reverse Torque Limit Accel	0.5	5-16

No.	Parameter Name	Initial Value	Ref Page#
B5-15	Reverse Torque Limit Decel	0.0	5-16
B6-01	Phase Loss Input Select	0	5-17
B6-02	Phase Loss Input Level	7.5	5-17
B6-03	Phase Loss Output Select	1	5-17
B6-04	Phase Loss Output Level	5.0	5-17
B8-01	Jump Frequency 1	0.0	5-18
B8-02	Jump Frequency 2	0.0	5-18
B8-03	Jump Frequency 3	0.0	5-18
B8-04	Jump Bandwidth	1.0	5-18
C1-01	Quick Stop Enable/Disable	0	5-20
C1-02	Quick Stop Time	0	5-20
C1-03	Reverse Plug Enable/Disable	0	5-21
C1-04	Reverse Plug Decel Time	1.0	5-21
C1-05	Reverse Plug Accel Time	1.0	5-21
C2-01	Micro Speed Gain 1	1.00	5-22
C2-02	Micro Speed Gain 2	1.00	5-22
C3-01	Upper Limit 1 Speed	6	5-23
C3-02	Upper Limit 1 Decel Time	1.0	5-23
C3-03	Upper Limit 2 Decel Time	0.5	5-23
C3-04	Lower Limit 1 Speed	6	5-23
C3-05	Lower Limit 1 Decel Time	1.0	5-23
C3-06	Lower Limit 2 Decell Time	0.5	5-23
C3-07	Action @ LL2/UL 2	0	5-23
C5-01	Load Check Enable/Disable	0	5-25
C5-02	Load Check Alarm Action	2	5-25
C5-04	Look Speed 1	6	5-25
C5-05	Current Ref for Look Speed 1	160	5-25
C5-06	Vector Torque Reference	125	5-25
C5-07	Look Speed 2	20	5-25
C5-08	Current Ref for Look Speed 2	160	5-25
C5-09	Look Speed 3	60	5-25
C5-10	Current Ref for Look Speed 3	160	5-25
C5-11	Current Ref for > Look Speed 3	160	5-25
C5-12	Load Check Setting Time	0.20	5-25
C5-13	Load Check Test Time	0.10	5-25
C5-14	Load Check Fault Speed	6	5-25
C6-01	Swift/Ultra Lift Enable/Disable	0	5-27
C6-02	Swift Lift Forward Speed	60	5-27
C6-03	Swift Lift Reverse Speed	60	5-27
C6-04	Swift Lift Forward Torque	50	5-27
C6-05	Swift Lift Reverse Torque	30	5-27
C6-06	Swift Lift Enabling Speed	60	5-27
C6-07	Swift Lift Delay Time	2.0	5-27

No.	Parameter Name	Initial Value	Ref Page#
C6-08	SFS Acceleration Gain	1.0	5-27
C7-01	Forward Torque Limit	150	5-29
C7-02	Reverse Torque Limit	150	5-29
C7-03	Forward Regen Torque Limit	180	5-29
C7-04	Reverse Regen Torque Limit	180	5-29
C7-05	Torque Limit Gain	2.0	n/a
C7-06	Torque Limit Time	200	n/a
C7-07	T-Lim Gain Gain MFI	1.25	5-29
C8-04	Roll Back/BE4 Timer	0.50	5-29
C8-11	Brake Delay Time/BE5 Timer	0.7	5-29
C9-01	G5IN4 Enable/Disable	0	5-30
C9-02	G5IN4 Setup	0	5-20
C12-01	Brake Jog Delay	0.0	5-34
C12-02	Brake Run Delay	0.0	5-34
C13-01	Inch Run Time	1.00	5-34
C13-02	Repeat Delay Time	1.00	5-34
D1-01	DC Injection Start Frequency	2.0	5-36
D1-02	DC Injection Current	50	5-36
D1-03	DC Injection Time @ Start	0.00/0.20	5-36
D1-04	DC Injection Time @ Stop	0.05	5-36
D1-05	DC Injection P Gain	0.05	5-36
D1-06	DC Injection Integral Time	100	5-36
D1-07	DC Injection	15.0	5-36
D2-01	Slip Compensation Gain	1/0	5-38
D2-02	Slip Compensation Time	200/2000	5-38
D2-03	Slip Compensation Limit	200	5-38
D2-04	Slip Compensation Regen	0	5-38
D2-05	Slip Compensation V/F	0	5-38
D3-01	Torque Compensation Gain	1	5-40
D3-02	Torque CompensationTime	20/200	5-40
D6-01	Droop Quantity	0.0	5-41
D6-02	Droop Delay Time	0.05	5-41
D8-01	Dwell Reference @ Start	0.0	5-42
D8-02	Dwell Time @ Start	0.0	5-42
D8-03	Dwell Reference @ Stop	0.0	5-42
D8-04	Dwell Time @ Stop	0.0	5-42
D9-01	S-Curve Accel @ Start	1.50	5-43
D9-02	S-Curve Accel @ End	1.50	5-43
D9-03	S-Curve Decel @ Start	1.50	5-43
D9-04	S-Curve Decel @ Stop	0.00	5-43
D10-01	Carrier Frequency Max	3	5-45
D10-02	Carrier Frequency Min	3	5-45
D10-03	Carrier Frequency Gain	0	5-45

No.	Parameter Name	Initial Value	Ref Page#
D11-01	Hunt Prevention Select	1	5-46
D11-02	Hunt Prevention Gain	1.00	5-46
D12-08	AFR Gain	1.00	5-47
D12-09	AFR Time	50	5-47
D12-30	Carrier in Tune	0	5-47
E1-01	Input Voltage	230/460	5-48
E1-02	Motor Selection	0	5-49
E1-03	V/F Selection	00/04	5-49
E1-04	Max Frequency	60.0	5-49
E1-05	Max Voltage	230/460	5-49
E1-06	Base Frequency	60	5-49
E1-07	Mid Frequency A	3.0	5-49
E1-08	Mid Voltage A	39.0	5-49
E1-09	Min Frequency	1.3/0.5	5-49
E1-10	Min Voltage	22.2	5-49
E1-11	Mid Frequency B	0.0	5-49
E1-12	Mid Voltage B	0.0	5-49
E1-13	Base Voltage	460	5-49
E2-01	Motor Rated Full Load Amps	—	5-49
E2-02	Motor Rated Slip	—	5-51
E2-03	No load current	—	5-51
E2-05	Terminal Resistance	—	5-51
E2-06	Leakage Inductance	—	5-51
E2-07	Saturation Compensation 1	—	5-51
E2-08	Saturation Compensation 2	—	5-51
E3-01	Motor 2 Control Method	2	5-52
E3-02	Motion 2	1	5-52
E4-01	V/F 2 Max Frequency	60	5-52
E4-02	V/F 2 Max Voltage	230/460	5-52
E4-03	V/F 2 Base Frequency	60	5-52
E4-04	V/F 2 Mid Frequency	3.0	5-52
E4-05	V/F 2 Mid Voltage	12.6	5-52
E4-06	V/F 2 Min Frequency	0.5	5-52
E4-07	V/F 2 Min Voltage	2.3	5-52
E5-01	Motor 2 Rated Full Load Amps	—	5-53
E5-02	Motor 2 Rated Slip	—	5-53
E5-03	Motor 2 No Load Current	—	5-53
E5-05	Motor 2 Terminal Resistance	—	5-53
E5-06	Motor 2 Leakage Inductance	—	5-53
F2-01	AI-14 Input Select	0	5-54
F3-01	Digital Input Setup	0	5-55
F4-01	Analog Out Channel 1 Select	2	5-56
F4-02	Analog Out Channel 1 Gain	1.00	5-56

No.	Parameter Name	Initial Value	Ref Page#
F4-03	Analog Out Channel 2 Select	3	5-56
F4-04	Analog Out Channel 2 Gain	0.50	5-56
F5-01	Digital Out Channel 1 Select	0	5-57
F5-02	Digital Out Channel 2 Select	1	5-57
F6-01	DO-08 Select	0	5-57
F7-01	PO-36F Select	1	5-57
H1-01	Terminal 3 Select	0	5-60
H1-02	Terminal 4 Select	1	5-60
H1-03	Terminal 5 Select	7	5-60
H1-04	Terminal 6 Select	9	5-60
H1-05	Terminal 7 Select	24	5-60
H1-06	Terminal 8 Select	E	5-60
H2-01	Terminal 9 Select	0	5-63
H2-02	Terminal 25 Select (G5OUT1)	0	5-63
H2-03	Terminal 26 Select (G5OUT2)	7F	5-63
H3-01	Terminal 13 Signal	0	5-66
H3-02	Terminal 13 Gain	100.0	5-68
H3-03	Terminal 13 Bias	0.0	5-68
H3-04	Terminal 16 Signal	0	5-68
H3-05	Terminal 16 Select	0	5-68
H3-06	Terminal 16 Gain	100.0	5-69
H3-07	Terminal 15 Bias	0.0	5-69
H3-08	Terminal 14 Signal	2	5-69
H3-09	Terminal 14 Select	1F	5-69
H3-10	Terminal 14 Gain	100.0	5-69
H3-11	Terminal 14 Bias	0.0	5-69
H3-12	Filter Average Time	0.00	5-69
H4-01	Terminal 21 Select	2	5-70
H4-02	Terminal 21 Gain	1.00	5-70
H4-03	Terminal 21 Bias	0.0	5-70
H4-04	Terminal 23 Select	3	5-70
H4-05	Terminal 23 Gain	1.00	5-70
H4-06	Terminal 23 Bias	0.0	5-70
H4-07	Analog Out Level Select	0	5-70
H5-01	Serial Comm Address	1F	5-71
H5-02	Serial Baud Rate	3	5-71
H5-03	Serial Communication Parity	0	5-71
H5-04	Action @ Serial Fault Select	1	5-71
H5-05	Serial Fault Enable/Disable	1	5-71
L1-01	Motor Overload Fault Select	1	5-70
L1-02	Motor Overload Time Constant	1.0	5-72
L3-01	Stall Prevention Accel Select	1	5-73
L3-02	Stall Prevention Accel Level	150	5-73

No.	Parameter Name	Initial Value	Ref Page#
L3-03	Stall Prevention Constant HP Level	50	5-75
L3-04	Stall Prevention Decel Select	0	5-75
L3-05	Stall Prevention Run Select	1	5-77
L3-06	Stall Prevention Run Level	160	5-78
L4-01	Speed Agree Level	0.0	5-79
L4-02	Speed Agree Width	2.0	5-79
L4-03	Speed Agree Level +/-	0.0	5-80
L4-04	Speed Agree Width +/-	2.0	5-80
L4-05	Reference Loss Select	0	5-80
L6-01	Torque Detection 1 Select	0	5-81
L6-02	Torque Detection 1 Level	150	5-82
L6-03	Torque Detection1 Time	0.1	5-82
L6-04	Torque Detection 2 Select	0	5-83
L6-05	Torque Detection 2 Level	150	5-83
L6-06	Torque Detection 2 Time	0.1	5-83
L8-02	Over Heat Pre-Alarm Level	95	5-84
L8-03	Over Heat Pre-Alarm Select	3	5-84
L8-10	Ground Fault Enable/Disable	1	5-84
L8-14	UV3 Enable/Disable	0	5-84
L9-01	Auto Reset Enable/Disable	1	5-85
L9-02	Reset Attempts	3	5-85
L9-03	Reset Time	0.5	5-85
L9-04	Reset Fault Select 1	1	5-85
L9-05	Reset Fault Select 2	80	5-85
O1-01	User Monitor Select	6	5-88
O1-02	Power On Monitor	2	5-89
O1-03	Display Scaling	0	5-89
O1-04	Display Units	0	5-90
O1-05	Address Display	0	5-90
O2-01	Mode/Service Key	0	5-90
O2-02	Operator Stop Key	0	5-90
O2-03	User Defaults	0	5-90
O2-04	KVA Selection	—	5-91
O2-05	Up/Down Frequency Reference	0	5-92
O2-06	Operator Detection	1	5-92
O2-07	Elapsed Time Set	0	5-92
O2-08	Elapsed Time Run	0	5-92
O3-01	Clear History 1	0	5-93
O3-02	Clear History 2	0	5-93
U1-01	Frequency Reference	—	5-94
U1-02	Output Frequency	—	5-94
U1-03	Output Current	—	5-94
U1-04	Control Method	—	5-94

No.	Parameter Name	Initial Value	Ref Page#
U1-05	Motor Speed	—	5-94
U1-06	Output Voltage	—	5-94
U1-07	DC Bus Voltage	—	5-94
U1-08	Output kWatts	—	5-94
U1-09	Torque Reference	—	5-94
U1-10	Input Term Status	—	5-94
U1-11	Output Term Status	—	5-94
U1-12	Inverter Control Status 1	—	5-94
U1-13	Elapsed Time	—	5-94
U1-14	Flash ID	—	5-94
U1-15	Terminal 13 Level	—	5-94
U1-16	Terminal 14 Level	—	5-94
U1-17	Terminal 16 Level	—	5-94
U1-18	Motor Secondary Current	—	5-94
U1-19	Motor Excitation Current	—	5-94
U1-20	SFS Output	—	5-94
U1-24	PID Feedback	—	5-94
U1-25	G5IN4 Monitor	—	5-94
U1-26	Voltage Reference (Vq)	—	5-94
U1-27	Voltage Reference (Vd)	—	5-94
U1-28	CPU Software ID Number	—	5-94
U1-32	ACR (q) Output	—	5-94
U1-33	ACR (d) Output	—	5-94
U1-34	OPE Detected	—	5-94
U1-35	Friction Torque	—	5-94
U2-01	Current Fault	—	5-95
U2-02	Last Fault	—	5-95
U2-03	Frequency Reference	—	5-95
U2-04	Output Frequency	—	5-95
U2-05	Output Current	—	5-95
U2-06	Motor Speed	—	5-95
U2-07	Output Voltage	—	5-95
U2-08	DC Bus Voltage	—	5-95
U2-09	Output kWatts	—	5-95
U2-10	Torque Reference	—	5-95
U2-11	Input Terminal Status	—	5-95
U2-12	Output Terminal Status	—	5-95
U2-13	Inverter Status	—	5-95
U2-14	Elapsed Time	—	5-95
U3-01	Last Fault	—	5-95
U3-02	Fault Message 2	—	5-95
U3-03	Fault Message 3	—	5-95
U3-04	Fault Message 4	—	5-95

No.	Parameter Name	Initial Value	Ref Page#
U3-05	Elapsed Time 1	—	5-95
U3-06	Elapsed Time 2	—	5-95
U3-07	Elapsed Time 3	—	5-95
U3-08	Elapsed Time 4	—	5-95
U3-09	AC Operations	—	5-95
U3-10	OL/LC Count	—	5-95

A p p e n d i x **B**

**Differences in
Software Versions**

This page intentionally left blank.

Important Product Upgrade Information

Changes in Software from 14906 to 14908/14909

Parameter	Description	Change
A1-04	Speed Reference	Default setting change from 5 step to 3 step at the request of many of our customers.
B5-01	Accel Time	Default settings modified to improve operational performance during acceleration and deceleration and extend drive life b reducing peak currents
B5-02	Decel Time	
D9-01	S-Curve Acceleration at Start	
D9-02	S-Curve Acceleration at End	
D9-03	S-Curve Deceleration at Start	
B6-02	Phase Loss In Level	Relocated from “factory level programming only” to Advance programming mode to allow customers greater flexibility in programming and troubleshooting the drive.
B6-04	Phase Loss Out Level	
D1-05	DC Injection P Gain	
D1-06	DC Injection Int. Gain	
D1-07	DC Injection Limit	
L8-10	Ground Fault Detection	
L8-14	UV3 Detection Selection	
C3-07	Upper action	Change in default setting at customers request to “decel to stop”. This change will reduce brake wear.
L8-01	DB resistor protection	Previously advance level programming feature changed to “factory setting only”.
L8-12	AVR Selection	
O2-09	Initial Mode Select	
L9-01	Reset Select	Changed at customer request to allow auto-reset of specific faults (UV1 and CE-communication errors).
L9-02	Rest Attempts	
L9-03	Reset Time	
L9-04	Reset Fault Select 1	
L9-05	Reset Fault Select 2	

Changes in Software from 14908/14909 to 14911

Parameter	Description	Change
B1-06	Reference 6	Added for Multi-Step Speeds 6, 7, and 8, see table on page 5-4. Expands multi-step inputs.
B1-07	Reference 7	
B1-08	Reference 8	
Parameters changed by X-Press Programming	Parameters changed by X-Press Programming	This enabled more parameters to be automatically changed based on Motion and Speed Reference. See Parameters Changed by X-Press Programming on pages 4-11 through 4-13.
H1-01 to H1-06	Data 40 "BE6 Up Speed	Created new digital MFI for data 40. Data 40 now reads "BE6 Up Speed". This input limits the speed in the raise direction to the frequency reference programmed in parameter C8-17. This was implemented mainly for dual hoist applications.
A1-04	Speed Reference	Added sub menu 7 to A1-04. Data 7 text reads "Not Used". This was created to avoid OPE3 faults when using the G5IN4 for controlling speed references. If A1-04=7, Digital MFI terminals 3~8 are programmed for data F "Not Used". See Parameters Changed by X-Press Programming on pages 4-11 through 4-13.
G5IN4 Table		Rearranged G5IN4 table with more practical data. See page 5-32.
D10-01	Carrier Frequency	Changed default to optimize performance.
C2-01/C2-02	Mirco Speed	Improved accuracy of Micro Speed calculation at Gain settings below 0.1.

Control Method (A1-02)	Motion (A1-03)	Stopping Method (B3-03)
0-V/F 2-Open Loop Vector	0- Traverse	0-Ramp to Stop
		1-Coast to Stop
		2-DC Inject to Stop
		3-Coast with Timer
	1-Standard Hoist	4-Ramp with Timer
		0-Ramp to Stop
		1-Coast to Stop
		2-DC Inject to Stop
		3-Coast with Timer
		5-Hoist to Stop

Appropriate Software Upgrades for 14911 would utilize Impulse Link 3.053, Data Pulse 2.001 and Data Logger v1.23.