

TELEMOTIVE 10K12 RECEIVER With *telePILOT*[™] & *telePENDANT*[™] TRANSMITTERS

Magnetek Material Handling

Radio Control Equipment

Instruction Manual



Telemotive

TCTX12M-1 Rev. B January 2006

Part Number: 30085T

©Copyright 2006 Magnetek Material Handling

Table of Contents

1- Service Information	3
2- Radio Controlled Crane Safety.....	4
3- General System Information.....	11
4- Installation Procedure	12
5- Operation.....	See Appropriate Transmitter Manual
6- Wiring Diagram	16
7- Programming.....	36
8- Servicing.....	43
9- Spare Parts	47

Section 1 – Service Information

U.S. Service Information

For questions regarding service or technical information, contact **1-866-MAG-SERV (1-866-624-7378)**.

Magnetek Material Handling
N49 W13650 Campbell Drive
Menomonee Falls, WI 53051

Telephone: 800-288-8178

Website: www.magnetekmh.com
e-mail: info@magnetekmh.com

Fax Numbers

Main: 800-298-3503
Sales: 262-783-3510
Service: 262-783-3508

For Canada Service Information Contact Berlet Electronics:

Phone: 1-905-564-2710
Fax: 1-905-564-2755



Telemotive Industrial Control trademarks: Boommate, GateMate, 10K, *inteleSmart*, Telemotive, *telePilot*, *telePendant*, Laser Guard, Teledrive, Teltec, TeleMotion are either trademarks or registered trademarks of Telemotive Industrial Controls.

Third-party trademarks: All other trademarks, trade names or company names referenced herein are used for identification only and are the property of their respective owners.

Section 2 – Radio Controlled Safety

2-1. Warnings, Cautions And Notes.

Through out this document **WARNING**, **CAUTION** and **NOTE** statements have been deliberately placed to highlight items critical to the protection of personnel and equipment.

WARNING – A warning highlights an essential operating or maintenance procedure, practice, etc. which if not strictly observed, could result in injury or death of personnel, or long term physical hazards. Warnings are highlighted as shown below:



CAUTION – A caution highlights an essential operating or maintenance procedure, practice, etc. which if not strictly observed, could result in damage to, or destruction of equipment, or loss of functional effectiveness. Cautions are highlighted as shown below:



NOTE – A note highlights an essential operating or maintenance procedure, condition or statement. Notes are shown as below:

NOTE

WARNINGS, CAUTIONS AND NOTES SHOULD NEVER BE DISREGARDED.

The safety rules in this section are not intended to replace any rules or regulations of any applicable local, state, or federal governing organizations. The following information is intended to be used in conjunction with other rules or regulations already in existence. It is important to read all of the safety information contained in this section before installing or operating the Radio Control System.

2-2. Critical Installation Considerations.

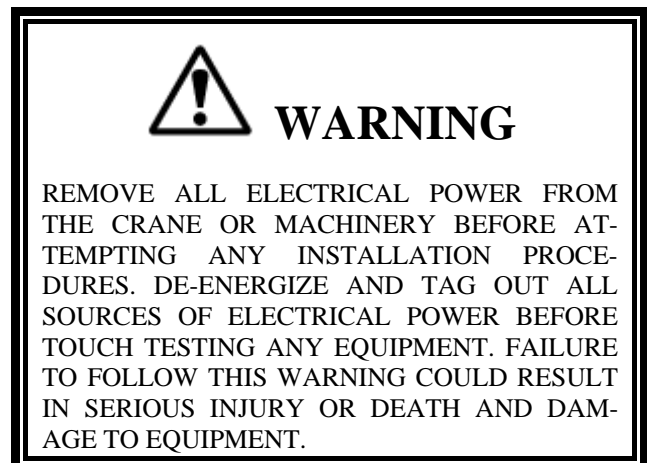
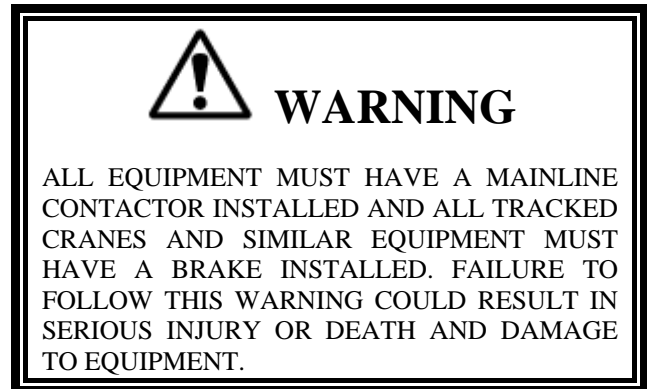

Section 2 – Radio Controlled Safety (Continued)



WARNING

THE DIRECT OUTPUTS OF THIS PRODUCT ARE NOT DESIGNED TO INTERFACE DIRECTLY TO TWO STATE SAFETY CRITICAL MAINTAINED FUNCTIONS, I.E., MAGNETS, VACUUM LIFTS, PUMPS, EMERGENCY EQUIPMENT, ETC. A MECHANICALLY LOCKING INTERMEDIATE RELAY SYSTEM WITH SEPARATE POWER CONSIDERATIONS MUST BE PROVIDED. FAILURE TO FOLLOW THIS WARNING COULD RESULT IN SERIOUS INJURY OR DEATH AND DAMAGE TO EQUIPMENT.

2-3. General.

Radio controlled overhead cranes and other material handling equipment operate in several directions. They are large, bulky pieces of equipment that handle heavy loads efficiently at high speeds. Quite frequently, the equipment is operated in areas where people are working on the floor below. The crane operator must exercise extreme caution at all times. Workers must constantly be alert to avoid accidents. The following rules have been included to indicate how your careful and thoughtful actions may prevent injuries, damage to equipment, or even save a life. If radio controlled material-handling equipment is operated from the cab, special care must be taken to secure the transmitter. Refer to section titled Section 2-9. Boarding The Crane for specific safety rules.

2-4. Persons Authorized To Operate Radio Controlled Cranes.

Only properly trained persons designated by management should be permitted to operate radio-controlled cranes.

Radio controlled cranes should not be operated by any person who cannot read or understand signs, notices and operating instructions that pertain to the crane.

Radio controlled cranes should not be operated by any person with insufficient eyesight or hearing or by any person who may be suffering from a disorder or illness or is taking any medication that may cause loss of crane control.

2-5. Training Checklist For Crane Operators.

Anyone being trained to operate a radio-controlled crane should possess as a minimum the following knowledge and skills before operating the crane:

The operator should have knowledge of hazards peculiar to crane operation.

The operator should have knowledge of the safety rules for radio-controlled cranes.

The operator should have the ability to judge distance or moving objects.

The operator should have knowledge of the radio transmitter.

The operator should know the limit switch test procedure.

The operator should know, where authorized, instructions for plugging motions.

The operator should have knowledge of the use of crane warning lights and alarms.

The operator should have knowledge of observing crane signal lights.

The operator should be trained to avoid striking any obstructions.

The operator should have knowledge of the proper clearance of lifts or hooks before moving bridge or trolley.

The operator should have knowledge of the proper storage space for radio control box when not in use.

The operator should be trained in transferring radio control box to another person.

The operator should be trained how and when to report unsafe or unusual operating conditions.

The operator should be trained how to exhibit caution in approaching bridge or trolley bumpers.

The operator should know equipment capacity.

The operator should be trained in making lifts below floor level.

The operator should be trained in making side pulls.

The operator should know how to keep himself and other people clear of lifts and to avoid "pinch" points.

Section 2 – Radio Controlled Safety (Continued)

The operator should know cable and hook inspection procedures.

The operator should know procedures for testing hoist, trolley, and bridge brakes.

2-6. Operating Area.

Aisles between equipment, stock, etc., should be free of obstructions so the crane operator can move freely. These aisles should be a minimum of three feet (one meter) wide, or meet local regulations.

Crane operators should always position themselves for the best view of the crane they are controlling. The crane should never be operated blindly. The operator should stay as close to the crane load as possible. Operators should never position themselves in a "pinch" point.

2-7. Transmitter Unit.

Transmitter switches should never be mechanically blocked ON or OFF for any crane motion. When not in use turn the transmitter OFF. A secure storage space should be provided for the transmitter unit and the transmitter unit should always be placed there when not in use. This precaution will prevent unauthorized people from operating the crane.

Spare transmitters should be stored in a secure storage space and only removed from the storage space after the current transmitter in use has been turned OFF, taken out of the service area and secured.

Before putting the transmitter in service the transmitter unit should be inspected for any damage or excessive wear. Units with, but not limited to, any of the following: broken housings, switches or handles, missing battery doors, switch boots or switch knobs should be repaired before putting into service.

2-8. Operating The Crane.

2-8.1. Pre-operation Test.

At the start of each work shift, or when a new operator takes control of the crane, operators shall do as a minimum the following steps before making lifts with any crane or hoist:

Test the upper-limit switch. Slowly raise the unloaded hook block until the limit switch trips. When checking limit switches the hoist should be

centered over an area free of personnel and equipment.

Visually inspect the hook, load lines, trolley, and bridge as much as possible from the operator's station; in most instances, this will be the floor of the building.

The bridge and trolley brakes should be tested. On transmitter units equipped with two or more speeds, use the "lowest" speed when testing braking devices.

When lifting maximum loads, the crane operator should test the hoist brakes by raising the load a few inches from the floor. If the brakes do not hold, the load should immediately be lowered to the floor.

If provided, test the lower-limit switch.

Test all warning devices.

Test all direction and speed controls for both bridge and trolley travel.

Test all bridge and trolley limit switches, where provided, if operation will bring the equipment in close proximity to the limit switches.

Test the transmitter emergency stop.

Test the hoist brake to verify there is no drift without a load.

If any crane or hoist that any of the above tests notify the supervisor and lock out and tag for repair.

2-8.2. General Rules For Operation.

Consult the crane manufacturer, local and governmental regulations for complete rules of operation. In general the following rules apply to remotely controlled cranes:

The limit switches should never be used as a regular stopping device. They are intended to be protective devices.

Do not make lifts in excess of the equipment rated capacity.

The bridge and trolley should be centered directly over the load when the load is raised to prevent swinging when making lifts.

A crane designed for this purpose and only with supervisor permission should make side pulls. When a lift is being made, the crane operator should not be

Section 2 – Radio Controlled Safety (Continued)

positioned in the line of travel. The crane or hoist should be operated from a position either to the side or opposite from the direction of travel.

When raising or lowering a load, proceed slowly and make certain the load is under control. Tag lines should be used for handling unusual lengths or bulky loads. Remove slack from chains or slings gradually. Make certain all personnel are clear before making a lift.

The crane operator should keep all body parts away from the lift and should never be positioned under the lift.

Do not make a lift or move a load if anyone is in a location where they could be struck by the crane or the load.

If the crane operator is being helped, the crane should not be moved until the helper signals they are clear of the crane and its load.

When a load is hanging from the crane hook and the crane is being moved, the crane operator should sound all warning devices frequently.

Loads should not be carried over workers heads. If a worker is in the path of crane travel, the crane operator should stop the crane and clear the area before proceeding.

Runway stops or other cranes should never be bumped into.

When moving the crane, the crane operator should be sure that the hook block and attachments or cables would not catch on nearby equipment. Slings, chains, or cables should never be dragged along the floor.

Unless required for operator safety, gloves should not be worn when operating the transmitter unit.

All loose materials or parts should be removed from the load before starting the lift.

The crane operator should always hoist lifts high enough to clear all equipment and workers.

The crane operator should never permit anyone to ride on the load or hook except when authorized by the supervisor.

When another crane on the same runway is stationary with a load hanging, the crane operator should maintain a safe distance between the stationary crane and the one under their control.

Never leave suspended loads unattended. In an emergency, if the crane is inoperative and a load suspended, notify the supervisor immediately, barricade and post signs on the floor beneath crane and load.

If power to the crane is removed, the crane operator should turn the transmitter unit OFF and keep it OFF until power is restored.

If the crane fails to respond properly, the crane operator should stop operation, turn the transmitter unit OFF and immediately report the condition to their supervisor.

Outdoor cranes, which are subject to movement by wind, should be securely anchored when left unattended. If the crane is equipped with bridge brakes, the parking brake should be set immediately.

2-9. Boarding The Crane.

The crane should not be boarded without permission of the supervisor.

The crane operator should turn off the transmitter and take it with them when boarding the crane.

If more than one person is boarding the crane, one person should be made responsible for ensuring all personnel are off the crane before the system is returned to operation.

2-10. Crane Maintenance And Repair.

Qualified personnel must maintain a regularly, i.e., such as monthly, scheduled crane inspection. During this crane inspection the functionality and safety of the crane remote control must also be tested. The inspection shall include, but be not limited to items listed in Section 2-12. Condition Of The Radio Controlled Crane. Consult crane manufacturer, local and governmental regulations for recommended inspection intervals and proper inspection procedures. Problems noted during this inspection must be repaired before using the crane or the remote control.

Minor repairs include routine maintenance and repairs such as greasing, cleaning and control troubleshooting. All other repairs should be considered major. If the repair crew consists of more than one person, one person should be designated as the repair crew leader with the following responsibilities. If the repair crew consists of only one person, that person has the following responsibilities:

Section 2 – Radio Controlled Safety (Continued)

For minor repairs warning signs should be placed on the floor beneath the crane or suspended from the crane. For major repairs, the floor area below the crane should be roped off.

When major repairs are to take place, all persons operating other cranes on the same or adjacent runways, if any, must be notified prior to starting repairs. Notification should include the nature of the repair, safeguards provided, and movement limitations while repairs are in progress.

When practical, radio controlled cranes which cannot be moved during repairs must be protected against being bumped by other cranes on the runway. Bumpers should be installed on the exposed side or sides of the crane under repair. They should be placed as far away as possible. The location of these bumpers should be indicated by red lights placed so that they are clearly visible to other crane operators traveling on the same runway. When it is not possible to use bumpers, red lights must be placed so they are clearly visible to other crane operators traveling on the same runway to indicate the restricted travel zone. All crane operators on the same runway must be informed of the repair effort and thoroughly instructed to what their operations are limited to and informed they will be notified when repairs are completed.

If any hazard involving the repairmen exists when there is a runway adjacent to the crane under repair, the adjacent runway should be blocked off as described above. When it is necessary to continue crane operation on the adjacent runways warning lights must be installed and be visible to operators of cranes on those runways. All cranes should come to a complete stop prior to entering the restricted area and should proceed through this area only after receiving permission from a signal person designated for this purpose. Access of persons to and from the crane being repaired should be under control of the repair crew leader.

When boarding the crane, the transmitter should be turned OFF and the transmitter should remain with the repair crew leader. The leader should board the crane first, open and lock out the main switch, and then signal the other members of the crew it is safe to board the crane.

If work on the crane is to be done in areas not protected by standard handrails, the repair crew should wear approved safety belts.

All tools and equipment should be moved onto the crane by the use of hand lines. The tools and equipment should be adequately secured to the hand lines.

If it is necessary to have the crane control circuits energized, all power circuits for crane movement must be opened prior to energizing the control circuits.

All personnel and tools should be moved to a safe spot before moving the crane during repairs.

Headroom is at a minimum in some crane cabs and on some crane walkways. Caution should be exercised when boarding or working on cranes. Hard hats should be worn whenever possible.

When repairs are finished, all personnel, tools and repair equipment should be removed before energizing the crane circuits.

2-11. Using The Crane As A Work Platform.

When the crane is to be used as a stationary work platform, follow all rules provided in Section 2-10. Crane Maintenance and Repair. When it is necessary for the crane to be moved from time to time, the crane operator should board the crane with the transmitter unit. The crane operator should ensure all personnel working on the crane are in a secure position before moving the crane to the next workstation. It should also be the crane operator's responsibility to ensure the main switch is open and locked down before work is resumed.

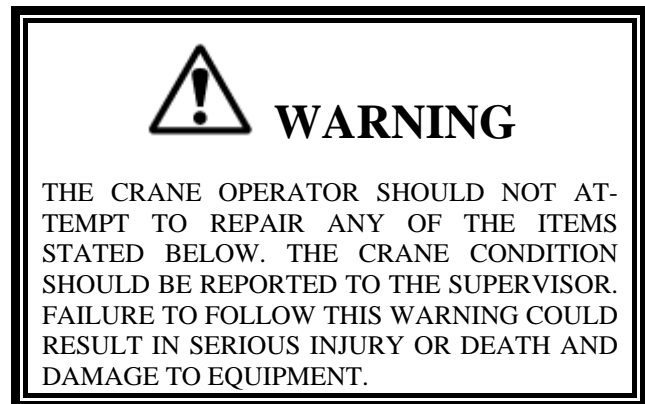

2-12. Condition Of The Radio Controlled Crane.

If the crane fails to respond properly, the crane operator(s) should notify their supervisor. When serious conditions are noticed (conditions that make the crane unsafe to operate), the crane should be shut

Section 2 – Radio Controlled Safety (Continued)

down immediately and the supervisor notified. The following is a list of some of the items that should be included in the report. (See the crane manufacturer for specifics and possible additional items):

Condition of hoisting cable and hook block (broken strands, clipped sheave wheels, etc.).

Condition of brakes (hoist, trolley, and bridge). (No bluing, rivets on shoes showing, glazing, etc.).

Condition of trolley and rail stops.

Condition of bridge structure.

Condition of festoon system.

Broken welds in any part of the crane structure.

Proper fluid levels and lubrication.

Condition of bridge and trolley stops.

Carbon dust or signs burning on the covers of motors.

Indication of fluid, oil or grease leaks.

Condition of rail sweeps.

Walkways required handrails and ladders are in place, sturdy and not loose.

Protective guards are in place for all moving parts.

Alignment of bridge (screeching or squealing wheels indicate bridge is out of line).

Broken, cracked, or chipped rails on trolley or runway.

Condition of limit switches.

Condition of electrical and mechanical control (electrical or mechanical defects which cause faulty operation such as un-commanded stopping or starting of any crane motions, warning devices, lights, or auxiliary functions).

Condition of gears (grinding or squealing may indicate foreign materials in gear teeth or a lack of lubrication).

All controls especially E-STOPS are in place and in working order.

Frequent relay tripping of power circuits.

Mechanical parts loosened by vibration (loose rivets, covers, bolts, etc.).

Uneven riding (worn or damaged wheels).

Condition of collector shoes or bars.

Condition of warning or signal lights and horns. (Burned out or broken).

2-13. Batteries

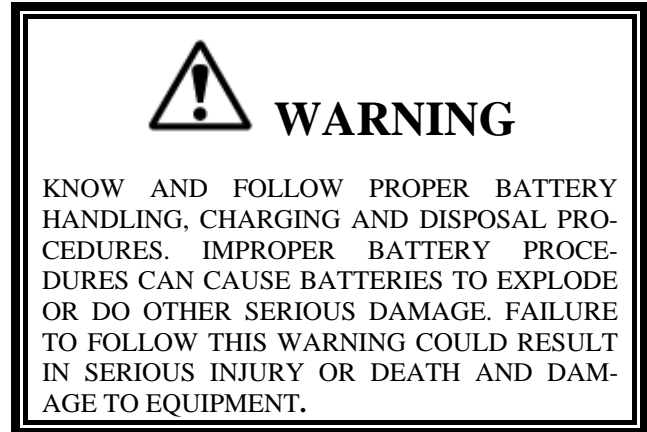

2-13.1. Battery Handling.

Use only batteries approved by Telemotive for the specific product.

Do not dispose of a battery pack in fire; it may explode.

Do not attempt to open the battery pack.

Do not short circuit battery.

For intrinsically safe environments only use specified Telemotive intrinsically safe batteries.

Keep the battery pack environment cool during charging operation and storage, (i.e., not in direct sunlight or close to a heating source).

2-13.2. Battery Charging.

For those transmitters equipped with battery chargers, please familiarize all users with the instructions of the charger before attempting to use.

Use only Telemotive approved chargers for the appropriate battery pack.

Do not attempt to charge non-rechargeable battery packs.

Section 2 – Radio Controlled Safety (Continued)

Avoid charging the battery pack for more than 24 hours.

Do not charge batteries in a hazardous environment.

Do not short charger.

Do not attempt to charge a damaged battery.

Do not attempt to use a battery that is leaking, swollen or corroded.

Charger units are not intended for outdoor use. Use only indoors.

2-13.3. Battery Disposal.

Before disposing of batteries consult local and governmental regulatory requirements for proper disposal procedures.

Section 3 – General System Information

3-1. General System Information.

The Telemotive Radio Control System (system) provides remote control of overhead cranes using radio signals. The system consists of a hand held portable battery operated transmitter unit and a fixed station receiver unit.

A unique 16-bit code (Access Code) for each system is preset in every transmitter and receiver. The receiver considers any received signal, which does not match the receiver access code setting, invalid. The Access Code is made up of 16-bits (65,000 combinations) and no two similar codes are assigned to any two Telemotive systems.

Up to four systems may be used with the same frequency in a 600-foot area (220 meters). Each transmitter operating on the same frequency may be operated in close proximity, not less than six feet (1.9 meters), to each other.

3-2. TMS Low Power Signaling.

TMS (Time Multiplexed Signaling) is a Telemotive proprietary high-speed packet data system. The system software is structured to minimize "on the air" transmission time of any transmitter. This allows for multiple transmitters to share a common frequency. The TMS system is designed so that a transmitter will send a signal for a predetermined ON time, and then will turn OFF. The length of transmitter ON time is referred to as data burst or packet. The packet length is a function of the quantity of data to be sent, and the data rate (baud). Once the packet is sent, the transmitter will turn OFF. This allows for other transmitters to time-share the same frequency when a transmitter has turned OFF. The TMS system software determines the OFF period and repetition rate of the ON period. Since each system has its own access code, up to 4 transmitters can share and have equal access to the same frequency. TMS also allows for reduced battery consumption and extended battery life.

These systems have low power pulsed signaling, FCC certified under Part 15 Telecommunications Code of Regulations, no license is required. The transmitter unit is frequency modulated, low power and is certified under the appropriate regulations. A license is not required for the transmitter or operator. Modifications to the RF section of this system are not permitted and could void FCC certification.

3-3. Channel Designations:

AK01 - 439.8 MHz	AK06 - 438.8 MHz
AK02 - 439.6 MHz	AK07 - 438.6 MHz
AK03 - 439.4 MHz	AK08 - 438.4 MHz
AK04 - 439.2 MHz	AK09 - 438.2 MHz
AK05 - 439.0 MHz	AK10 - 438.0 MHz

AK11 - 437.8 MHz	AK16 - 436.8 MHz
AK12 - 437.6 MHz	AK17 - 436.6 MHz
AK13 - 437.4 MHz	AK18 - 436.4 MHz
AK14 - 437.2 MHz	AK19 - 436.2 MHz
AK15 - 437.0 MHz	AK20 - 436.0 MHz

AKA00 - 433.125 MHz	AKA05 - 434.125 MHz
AKA01 - 433.325 MHz	AKA06 - 434.325 MHz
AKA02 - 433.525 MHz	AKA07 - 434.525 MHz
AKA03 - 433.725 MHz	AKA08 - 434.725 MHz
AKA04 - 433.925 MHz	

3-4. Receiver Specifications.

Receiver housing: NEMA 4.

Operating Temperature: -22° F to +158° F (-30° C to +70° C) ambient.

Humidity: up to 95 % (non-condensing).

Typical Operating Range: 200 feet (70 meters).

3-5. Receiver Unit.

The receiver unit consists of a synthesized RF module, antenna, power supply, microprocessor controlled output motor control and auxiliary function relays and mainline contactor relay. The receiver unit contains circuitry, which matches the frequency and access code of the transmitter.

Section 4 – Installation

4-1. Pre-Installation Considerations.

To ensure reliable and safe operation of the system, the following items must be considered before installing the receiver unit.

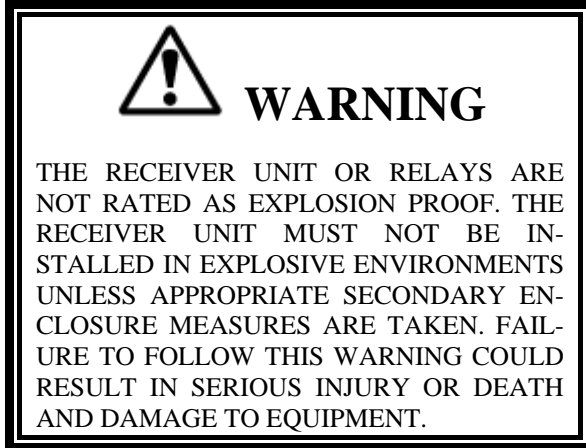

4-2. Receiver Unit Mounting Location Considerations.

Ensure the mounting location is as far as possible from exposed trolley wires and sources of electromagnetic or radiated noise

The receiver unit requires a mounting area of approximately 14" wide by 18" long. A depth of at least 18" must be provided to allow the cabinet door to open.

The mounting surface must be smooth and continuous. Mounting the cabinet on uneven surfaces could cause warpage or stress internal components.

The receiver unit may be mounted in any position. Greatest radio control range is obtained when the receiver unit is mounted with the antenna at the top.

If possible, avoid installing receiver unit to a surface where high vibration or shock is present. If this cannot be avoided, use appropriate shock mounts.

4-3. Antenna Mounting Considerations.

The antenna should not be placed near large metal objects that could be close to or cover the antenna. Allow at least six inches Around the antenna for clearance.

4-4. Line Input Considerations.

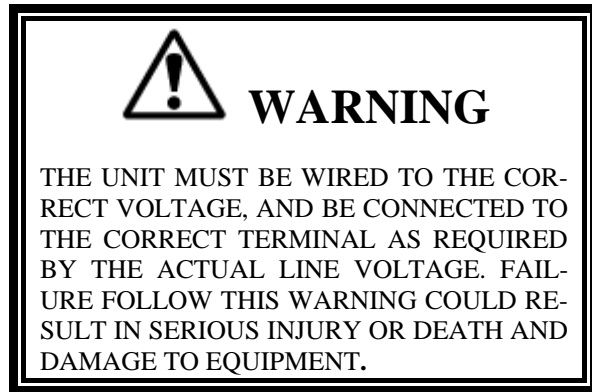

The receiver unit has direct and separate connect provisions for operation from 120 or 240 VAC (nominal), 50-60 Hz power.

For applications where line voltage deviation exceeds 20% of nominal values or if 440 VAC power is used, a step up or step down transformer must be used.

NOTE

THE RECEIVER UNIT SHOULD NOT BE CONNECTED TO LINES CONTAINING EXCESSIVE POWER UP TRANSIENTS OR CONTINUOUS COMMUTATOR NOISE. A LINE CONDITIONER MAY BE NECESSARY IN SOME INSTALLATIONS.

4-5. Wiring Considerations.

1. Read this manual before installation.
2. Please observe appropriate local and National Electrical Codes when wiring electrical devices.
3. Do not connect or disconnect wiring, or perform circuit checks while the power is turned on.
4. The motor wiring should be in a separate metal conduit from the power wiring, which should also be in metal conduit.
5. Low voltage wires shall be wired with proper low voltage class wiring procedures.

Section 4 – Installation (Continued)

6. Control wiring as well as antenna wiring shall be in separate conduit and shall be kept as short as possible.

7. All terminals shall be tightened to specified terminal torque 4.4 IN-LBS (.5 N·m). Unless otherwise specified.

8. Remove excess metal screws, metal filings and wire clippings from inside of unit.

9. Inspect to make sure no exposed wire has contact with any other wiring or terminals.

10. Suppressors are strongly recommended on all contactors.

4-6. Receiver/Equipment Interface Considerations.

All output relay contacts are rated at 16 Amps 110 VAC, 5 Amps 250 VAC and 28 VDC. Connection to equipment or contactors with higher voltage or current requirements will require intermediate relays.

All relay outputs are normally open, momentary contact. Since a relay closure is only active while the transmitter unit key is pressed and held, devices such as lights or lifting magnet must use a mechanical auxiliary latching relay.

4-7. Receiver Unit Cabinet Mounting.

See Figure 4-2. Receiver Mounting Details. Allow room in mounting the receiver for the door to swing open.

Mount receiver unit cabinet securely to mounting surface. Actual cabinet mounting dimensions are shown on Figure 4-2. Receiver Mounting Details.

4-8. Receiver Installation.

NOTE

CONNECTING OUTPUTS TO DRIVES.

MOV'S (TRANSIENT PROTECTORS) ARE ON ALL THE OUTPUT RELAYS TO PROTECT THE RELAYS FROM POWER SURGES. MOV'S ALLOW A SMALL LEAKAGE CURRENT THAT CAN AFFECT SOME HIGH IMPEDANCE CIRCUITS. WHEN CONNECTING OUTPUT RELAYS TO DRIVES, IT MAY BE REQUIRED TO REMOVE THE MOV TO PREVENT THE LEAKAGE CURRENT THROUGH THE MOV

FROM HOLDING IN THE DRIVE. SEE FIGURE 8-1. RECEIVER LAYOUT FOR THE LOCATION OF THE MOV'S. THE MOV'S ARE NEXT TO THE RELAYS THEY PROTECT. THE MOV'S CAN BE CUT OUT OF THE CIRCUIT WITH A WIRE CUTTER. REMEMBER TO DO THIS WITH ALL POWER OFF ON THE CRANE AND ALL ASSOCIATED CONTROLS.

1. Normally it should not be necessary to set the access codes, they are preset. Program the unit for any special crane configurations or other parameters, if desired, see Section 7. Programming for details.

2. Position the receiver. Locate as far as possible from exposed trolley wire and sources of electromagnetic or radiated noise. Cabinet mounting dimensions and mounting template is on next page see Figure 4-2. Receiver Mounting Details. Antenna should be kept as clear as possible of any metal object.

3. Mount the receiver. There are mounting holes on the top and bottom mounting flanges of the receiver. Recommended mounting hardware is 5/16" hex machine screws of appropriate length, with appropriate "keps" or elastic stop nuts. Flat washers should be used in front of nuts when receiver unit is mounted to a non structural surface. Mount receiver unit cabinet securely to mounting surface.

4. Wire the unit using the appropriate electrical drawings for the specific transmitter and crane orientation selected, see Section 6. Wiring. For the Membrane or Pendant transmitter determine crane orientation; if the direction pair labeled on the transmitter better describes the equipment movement. Use this pair to wire the motor directionals respectively. If you need to remove the main board (4 screws) the antenna unplugs from the RF Receiver, be sure to dress the antenna cable under the hook on the RF Receiver when reinstalling the antenna cable.

5. Wire the power to J1 input power connector. The connections are Ground (GND), Neutral (N) and 120 or 220 VAC 50-60 Hz. See Figure 4-1. Input Power Connections.

Section 4 – Installation (Continued)

6. Wiring of the system should now be complete.
7. Turn switch SW1 OFF (Receiver CPU Board) and SW1 ON (Power Supply Board). Stand clear of the crane and apply AC power to receiver unit. Check to see if the following LEDs are lit: (green DS1 (on steady), green DS2 (on steady), yellow DS8 (on steady), yellow DS10 (flashing), yellow DS14 (on steady) and red RF Receiver ON (on steady). If none are lit check AC power, power switch SW1 and fuse. See Figure 8-1. for LED locations.
8. Turn transmitter ON. Check to see if the yellow LED is now lit (DS4). At this point the MR relay is disabled, the functions of the transmitter can be checked by noting the turning ON of the appropriate red LEDs next to the control relays (K1-K6) on the two output boards positions A and B. After checking out the functions, turn switch SW1 ON (Receiver CPU Board) to enable the MR relay (red LED DS3 should now turn ON), check function and direction by jogging each motion. Installation should now be complete.
9. If there are any problems see Section 8. Servicing.

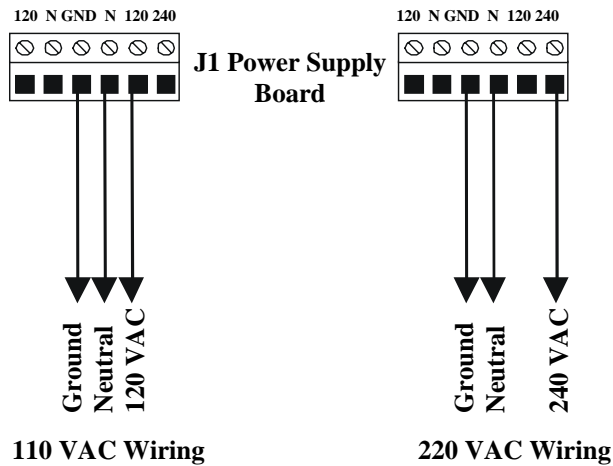

Figure 4.1 Input Power Connections

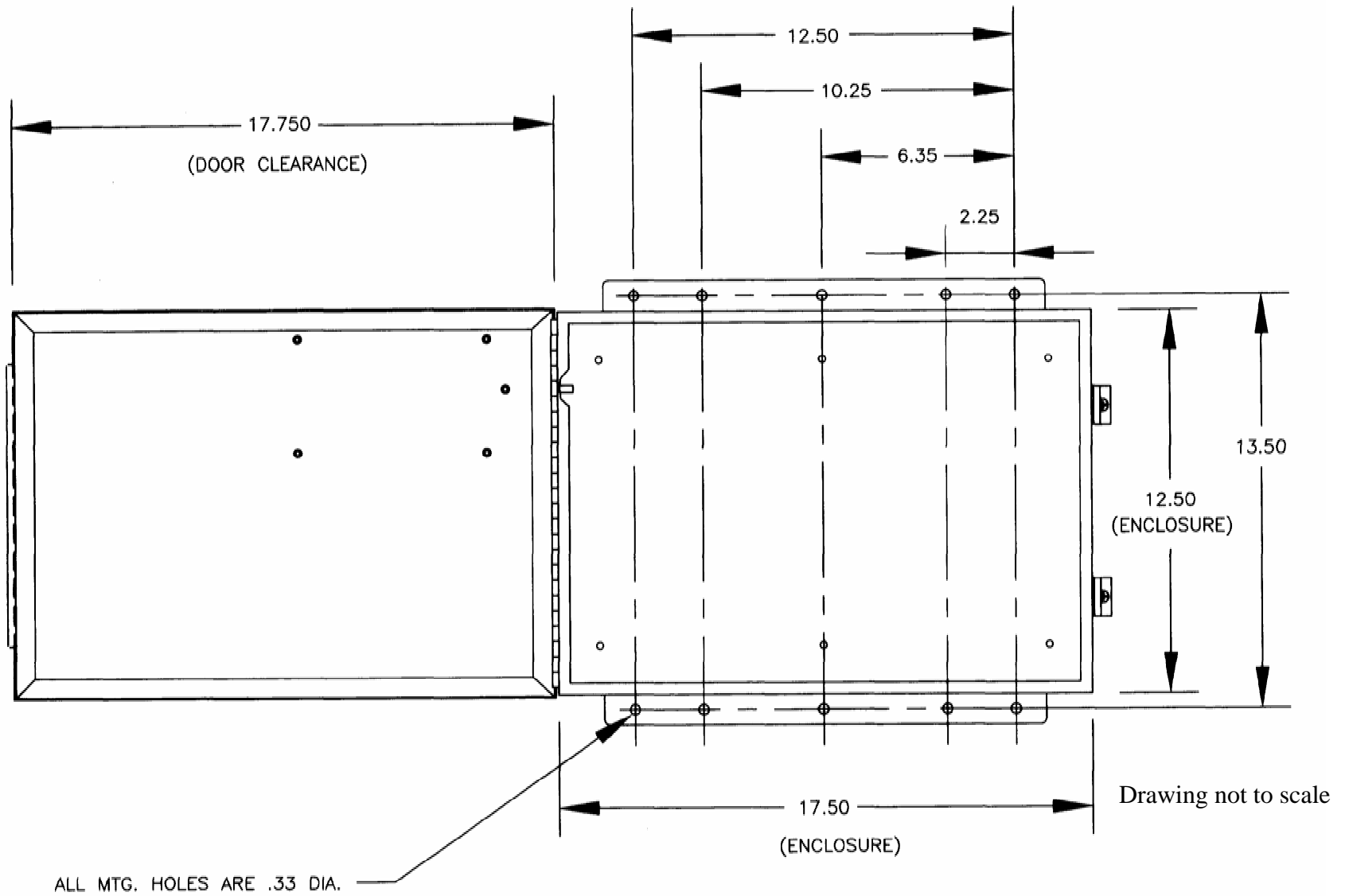

Figure 4.2 Receiver Mounting Details

Section 6 – Wiring

6-1. Wiring Diagrams.

Your system comes pre-programmed. The following pages in this section have individual wiring diagrams for different crane configurations. Find the appropriate wiring diagram and if necessary set the Configuration Switch to match the S3 Switch Settings shown in the appropriate diagram. Terminal designators are marked on the wiring diagram corresponding to designators found on the Receiver Board. For terminal locations see Figure 8-1. Receiver Layout. After selecting the appropriate motors for each function remember to use the appropriate label on your transmitter for describing the appropriate command.

6-2. Installation.

Follow Section 4. Installation Procedure for instructions on how to install the receiver.

6-3. Alarms And Horns.

Make sure that the installation includes the proper alarms, horns, indicator lights and their associated controls as required by local and governmental regulations.

6-4. Relay Sequencing.

At the top of the left hand page for each configuration is shown the appropriate relay sequencing on each wiring configuration. Check to see if the configuration sequencing is correct for the application. An “X” on the grid indicates a relay closure on the labeled output for that position of the specified switch.

6-5. Alarm After E-STOP.

This is only for wiring configurations where the Aux 3 (relay K1 Relay Output Board A, output A1) is being used for the Alarm function, placing a jumper on JU2 on the Receiver CPU Board will allow the alarm to function after an E-STOP command. See Figure 8-1. Receiver Layout for jumper location.

6-6. Connecting Outputs To Drives.

MOV's (transient protectors) are on all the output relays to protect the relays from power surges. MOV's allow a small leakage current that can affect some high impedance circuits. When connecting output relays to drives, it may be required to remove the MOV to prevent the leakage current through the MOV from holding in the drive. See Figure 8-1. Receiver Layout for the location of the MOV's. The MOV's are next to the relays they protect. The MOV's can be cut out of the circuit with a wire cutter. Remember to do this with ALL power OFF on the crane and all associated controls.

Section 6 – Wiring (Continued)

Legend

The following is the legend for the wiring diagrams below:

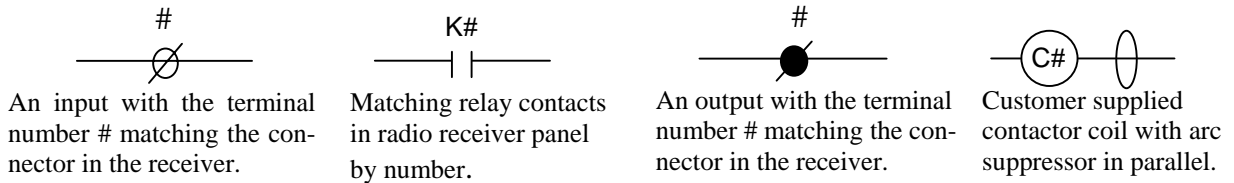
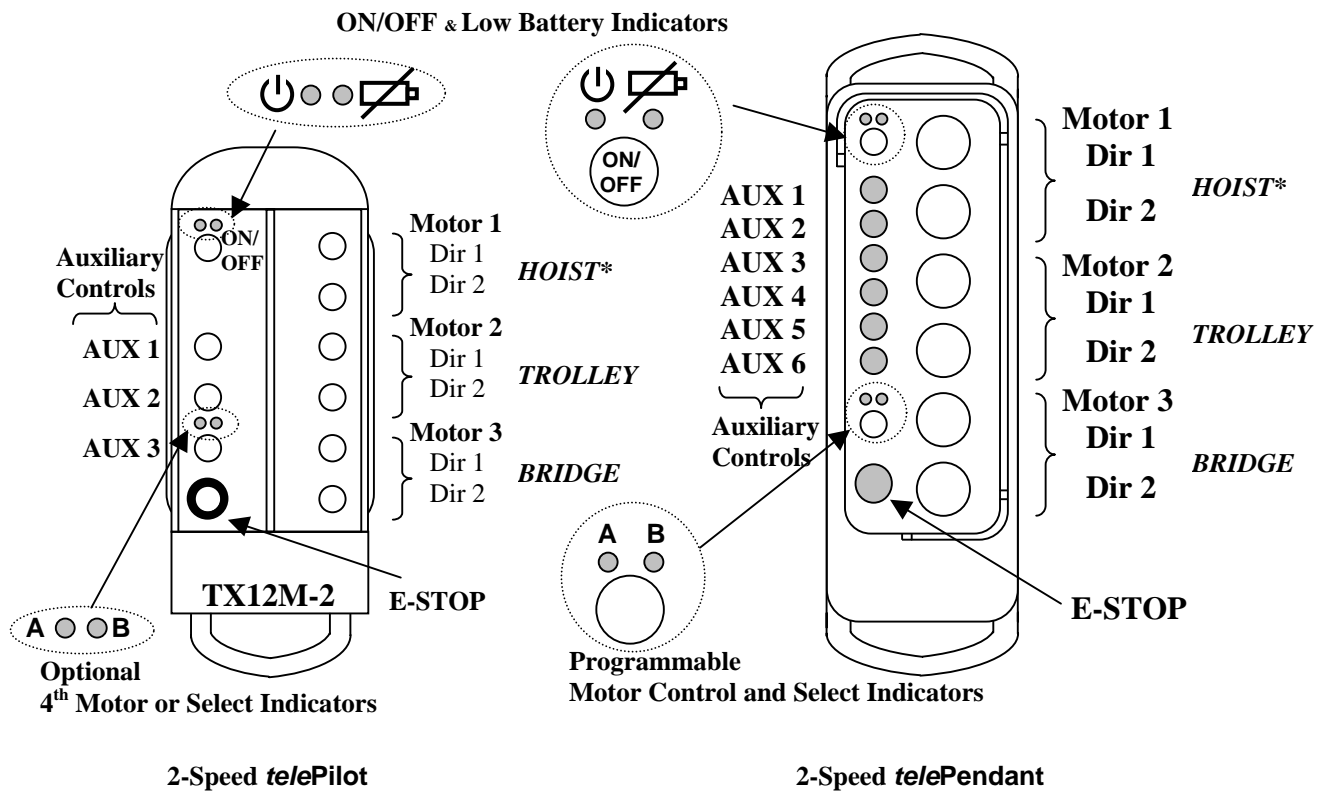

Figure 6-1. Legend.



*NOTE: Hoist, Trolley and Bridge are listed here as traditional configurations, the installer may choose to define the motors differently.

Figure 6-2. telePilot and telePendant, Output Controls

Section 6 – Wiring (Continued)

**TABLE 2(A) 2-SPEED WIRING DIAGRAM.
STANDARD CONFIGURATION HOIST, TROLLEY AND BRIDGE**

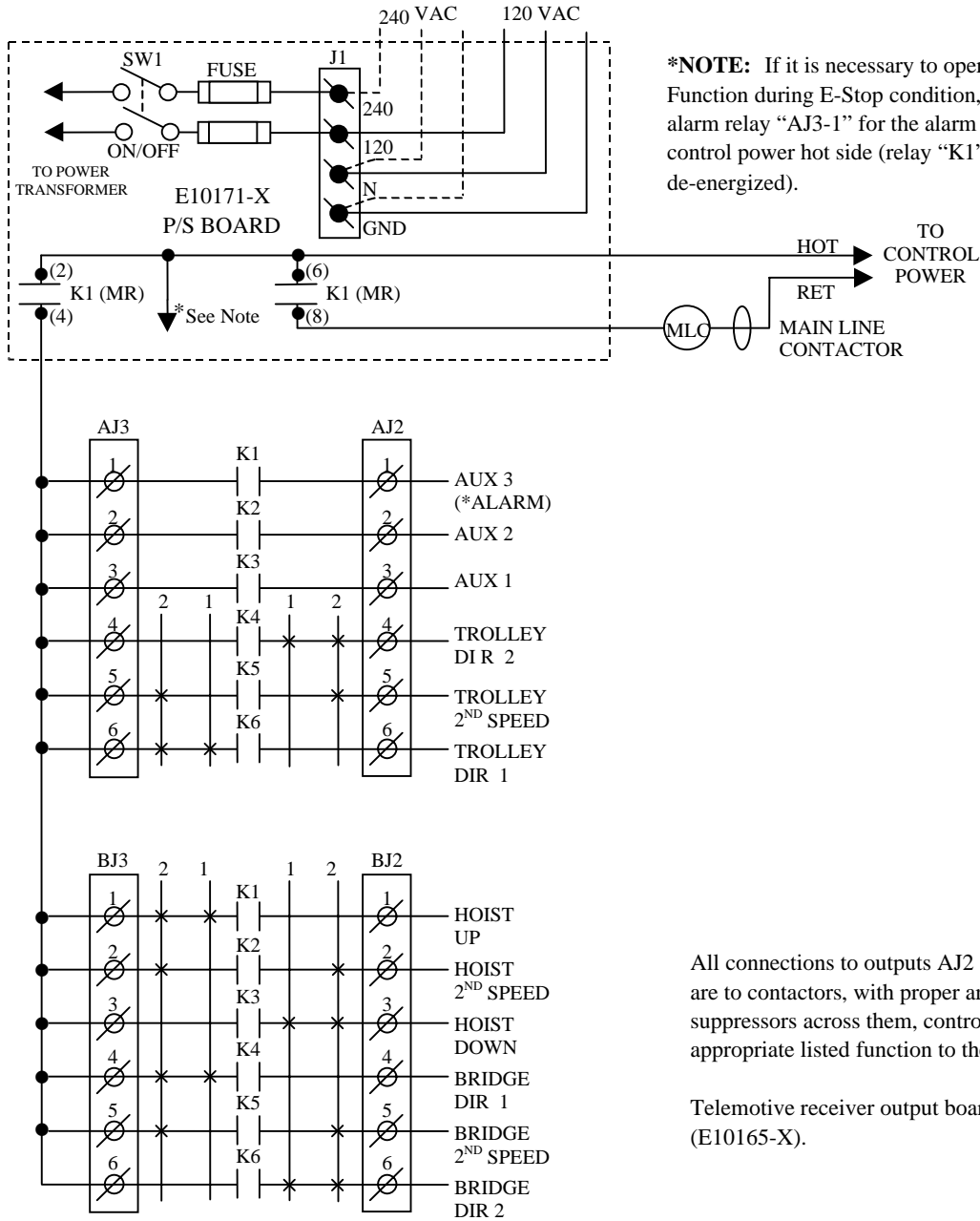

All connections to outputs AJ2 and BJ2 are to contactors, with proper arc suppressors across them, controlling the appropriate listed function to the right.

Telemotive receiver output boards (E10165-X).

Section 6 – Wiring (Continued)

**TABLE 2(A) 2-SPEED PROGRAMMING DIAGRAM.
STANDARD CONFIGURATION HOIST, TROLLEY AND BRIDGE**

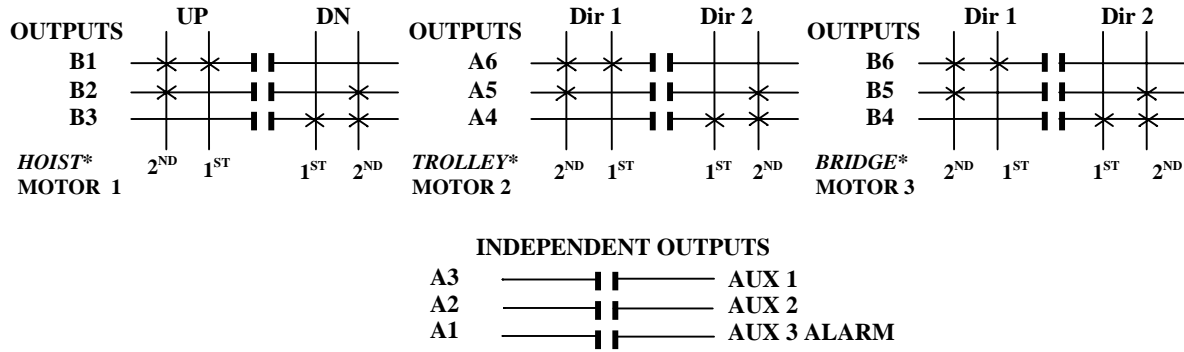

MOTOR 1 CONNECTIONS

B1 HOIST UP
B2 HOIST 2ND SPEED
B3 HOIST DOWN

MOTOR 2 CONNECTIONS

A6 TROLLEY DIR 1
A5 TROLLEY 2ND SPEED
A4 TROLLEY DIR 2

MOTOR 3 CONNECTIONS

B4 BRIDGE DIR 1
B5 BRIDGE 2ND SPEED
B6 BRIDGE DIR 2

INDEPENDENT CONNECTIONS

A3 AUX 1 (LATCHABLE S2-7)
A2 AUX 2 (LATCHABLE S2-6)
A1 AUX 3 ALARM

TRANSMITTER SWITCH SETTINGS

telePilot or telePendant USE PDA SCREEN (Program the configuration switches 5, 6 and 7 to OFF. Under “Main/Aux” select the setting “Aux”).

MEMBRANE USE SW3 “C”

PENDANT, JLTX AND SLTX USE SW4 “D”

TRANSMITTER SWITCH SETTINGS:

**Position-5
OFF**

**Position -6
OFF**

**Position -7
OFF**

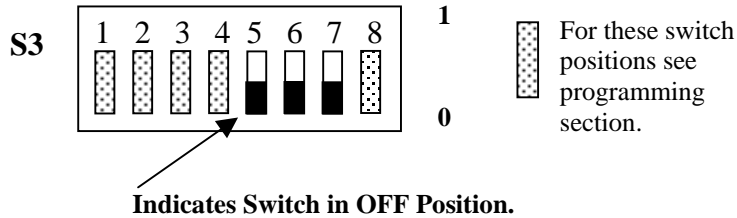

***NOTE:** Hoist, Trolley and Bridge are listed here as traditional configurations, the installer may choose to define the motors differently.

Section 6 – Wiring (Continued)

TABLE 2(B) 2-SPEED WIRING DIAGRAM.
2-SPEED with DIRECTIONAL CONTROLS: ALL MOTIONS

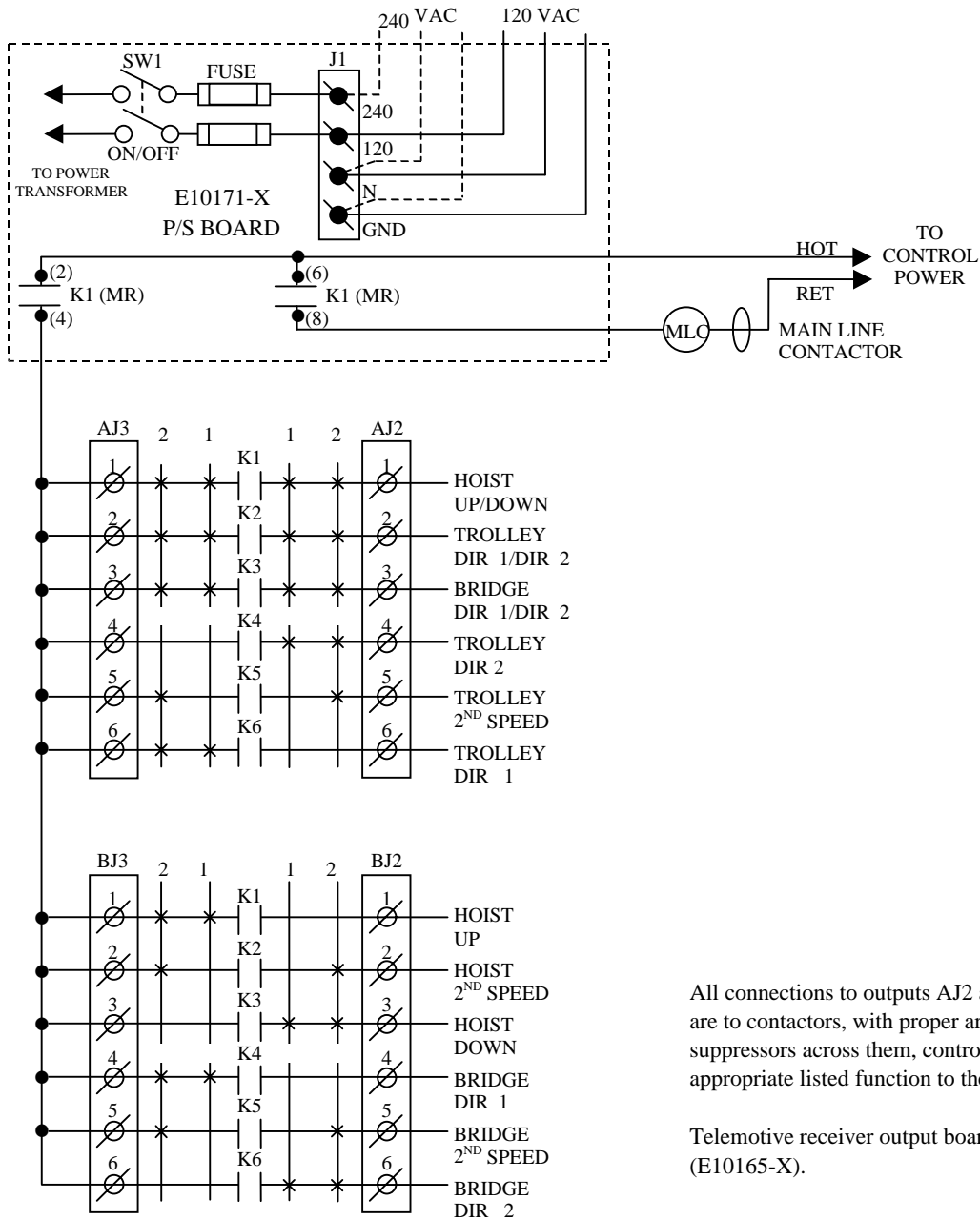

Section 6 – Wiring (Continued)

**TABLE 2(B) 2-SPEED PROGRAMMING DIAGRAM.
2-SPEED with DIRECTIONAL CONTROLS: ALL MOTIONS**

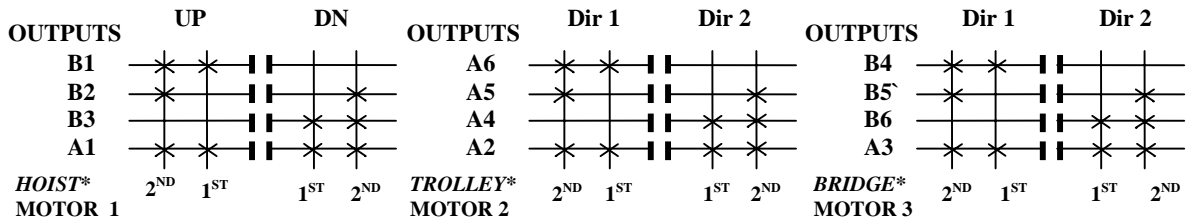

MOTOR 1 CONNECTIONS

B1 *HOIST* UP
 B2 *HOIST* 2ND SPEED
 B3 *HOIST* DOWN
 A1 *HOIST* UP/DOWN

MOTOR 2 CONNECTIONS

A6 *TROLLEY* DIR 1
 A5 *TROLLEY* 2ND SPEED
 A4 *TROLLEY* DIR 2
 A2 *TROLLEY* DIR1/DIR2

MOTOR 3 CONNECTIONS

B4 *BRIDGE* DIR 1
 B5 *BRIDGE* 2ND SPEED
 B6 *BRIDGE* DIR 2
 A3 *BRIDGE* DIR1/DIR2

NOTE

CHECK GOVERNMENTAL AND LOCAL REGULATIONS ON THE REQUIREMENTS OF HORNS OR ALARMS BEFORE USING THIS CONFIGURATION, AS THERE IS NOT A SEPARATE ALARM CONTROL.

TRANSMITTER SWITCH SETTINGS

telePilot or telePendant USE PDA SCREEN (Program the configuration switches 5, 6 & 7 to match the settings shown below).

MEMBRANE USE SW3 “C”

PENDANT, JLTX AND SLTX USE SW4 “D”

TRANSMITTER SWITCH SETTINGS:

**Position-5
ON**

**Position -6
OFF**

**Position -7
OFF**

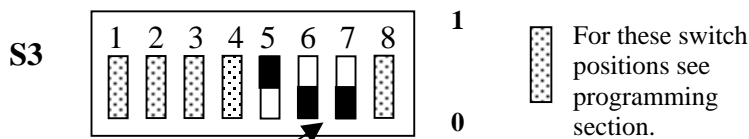

Indicates Switch in OFF Position.

*NOTE: Hoist, Trolley and Bridge are listed here as traditional configurations, the installer may choose to define the motors differently.

Section 6 – Wiring (Continued)

**TABLE 2(C) 2-SPEED PROGRAMMING DIAGRAM.
2-SPEED, 2-WINDINGS: ALL MOTIONS**

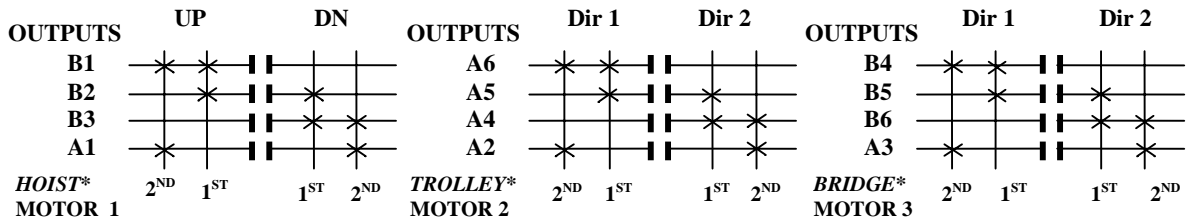

MOTOR 1 CONNECTIONS

B1 *HOIST* UP
 B2 *HOIST* LOW SPEED
 B3 *HOIST* DOWN
 A1 *HOIST* HIGH SPEED

MOTOR 2 CONNECTIONS

A6 *TROLLEY* DIR 1
 A5 *TROLLEY* LOW SPEED
 A4 *TROLLEY* DIR 2
 A2 *TROLLEY* HIGH SPEED

MOTOR 3 CONNECTIONS

B4 *BRIDGE* DIR 1
 B5 *BRIDGE* LOW SPEED
 B6 *BRIDGE* DIR 2
 A3 *BRIDGE* HIGH SPEED

NOTE

CHECK GOVERNMENTAL AND LOCAL REGULATIONS ON THE REQUIREMENTS OF HORNS OR ALARMS BEFORE USING THIS CONFIGURATION, AS THERE IS NOT A SEPARATE ALARM CONTROL.

TRANSMITTER SWITCH SETTINGS

telePilot or telePendant USE PDA SCREEN (Program the configuration switches to match the pattern and position shown).

MEMBRANE USE SW3 “C”

PENDANT, JLTX AND SLTX USE SW4 “D”

TRANSMITTER SWITCH SETTINGS:	Position-5 OFF	Position -6 ON	Position -7 OFF
------------------------------	-------------------	-------------------	--------------------

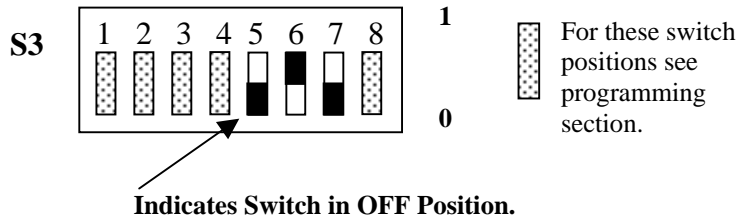

*NOTE: Hoist, Trolley and Bridge are listed here as traditional configurations, the installer may choose to define the motors differently.

Section 6 – Wiring (Continued)

**TABLE 2(D) 2-SPEED WIRING DIAGRAM.
ACCO CONTROLS: ALL MOTIONS**

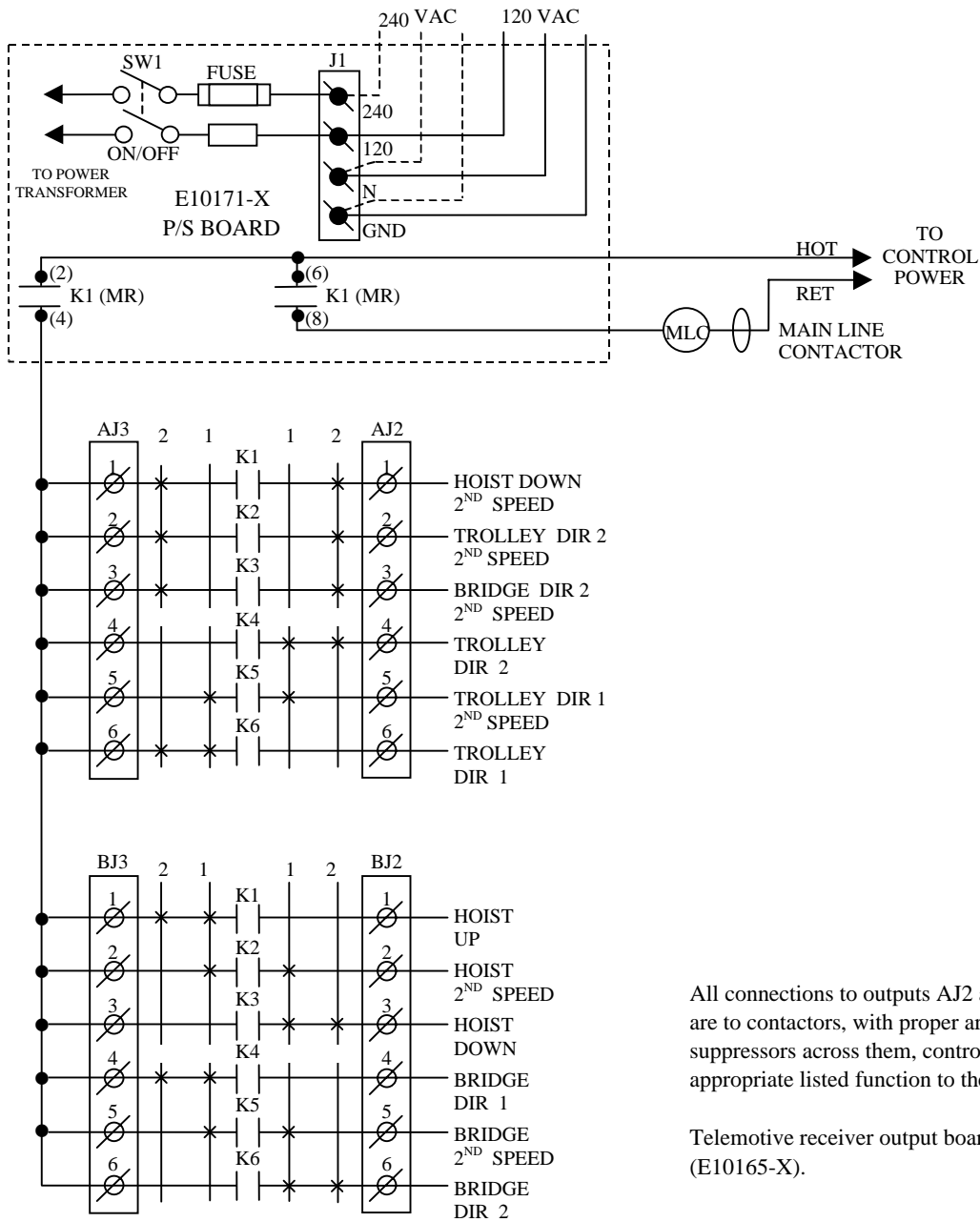

Section 6 – Wiring (Continued)

**TABLE 2(D) 2-SPEED PROGRAMMING DIAGRAM.
ACCO CONTROLS: ALL MOTIONS**

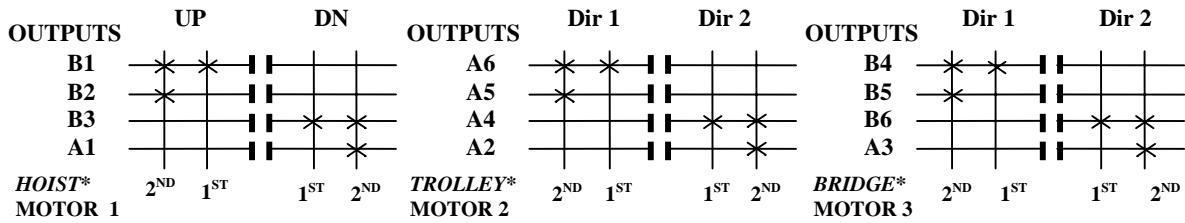

MOTOR 1 CONNECTIONS

B1 *HOIST* UP
 B2 *HOIST* 2ND SPEED UP
 B3 *HOIST* DOWN
 A1 *HOIST* 2ND SPEED DOWN

MOTOR 2 CONNECTIONS

A6 *TROLLEY* DIR 1
 A5 *TROLLEY* 2ND SPEED DIR 1
 A4 *TROLLEY* DIR 2
 A2 *TROLLEY* 2ND SPEED DIR 2

MOTOR 3 CONNECTIONS

B4 *BRIDGE* DIR 1
 B5 *BRIDGE* 2ND SPEED DIR 1
 B6 *BRIDGE* DIR 2
 A3 *BRIDGE* 2ND SPEED DIR 2

NOTE

CHECK GOVERNMENTAL AND LOCAL REGULATIONS ON THE REQUIREMENTS OF HORNS OR ALARMS BEFORE USING THIS CONFIGURATION, AS THERE IS NOT A SEPARATE ALARM CONTROL.

TRANSMITTER SWITCH SETTINGS

telePilot or *telePendant* USE PDA SCREEN (Program the configuration switches 5, 6 & 7 to match the settings shown below).

MEMBRANE USE SW3 “C”

PENDANT, JLTX AND SLTX USE SW4 “D”

TRANSMITTER SWITCH SETTINGS:

**Position-5
ON**

**Position -6
ON**

**Position -7
OFF**

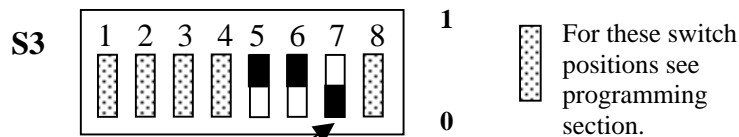

Indicates Switch in OFF Position.

*NOTE: Hoist, Trolley and Bridge are listed here as traditional configurations, the installer may choose to define the motors differently

Section 6 – Wiring (Continued)

**TABLE 2(E) 2-SPEED WIRING DIAGRAM.
P&H: 2-SPEED, 2-WINDINGS for HOIST and TROLLEY;
STANDARD BRIDGE**

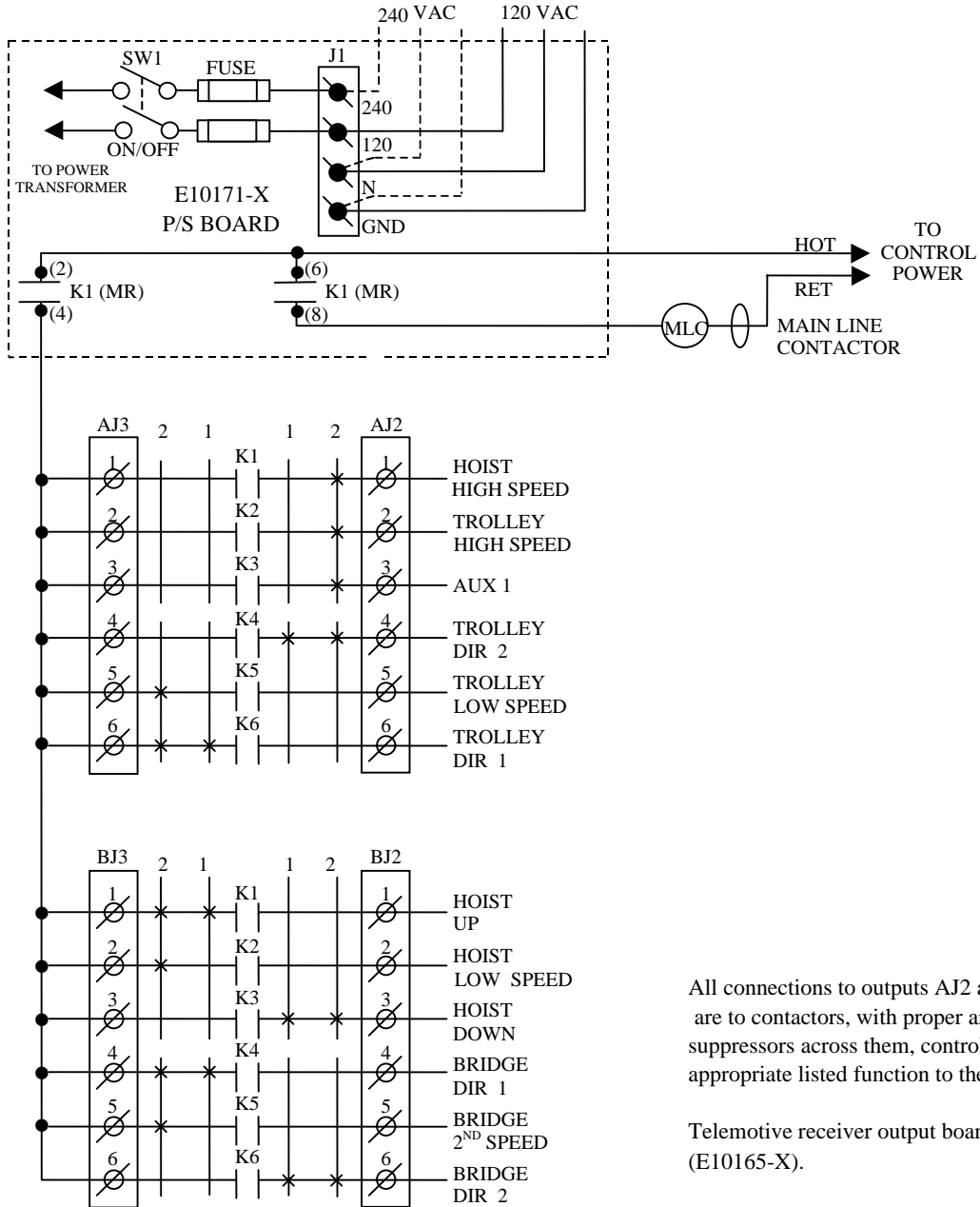

Section 6 – Wiring (Continued)

**TABLE 2(E) 2-SPEED PROGRAMMING DIAGRAM.
P&H: 2-SPEED, 2-WINDINGS for HOIST and TROLLEY;
STANDARD BRIDGE**

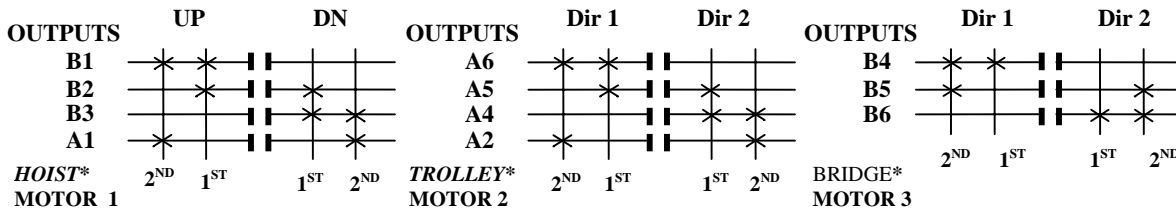

MOTOR 1 CONNECTIONS

- B1 *HOIST* UP
- B2 *HOIST* LOW SPEED
- B3 *HOIST* DOWN
- A1 *HOIST* HIGH SPEED

MOTOR 2 CONNECTIONS

- A6 *TROLLEY* DIR 1
- A5 *TROLLEY* LOW SPEED
- A4 *TROLLEY* DIR 2
- A2 *TROLLEY* HIGH SPEED

MOTOR 3 CONNECTIONS

- B4 *BRIDGE* DIR 1
- B5 *BRIDGE* 2ND SPEED
- B6 *BRIDGE* DIR 2

INDEPENDENT CONNECTIONS

- A3 AUX 1 (LATCHABLE S2-7)

TRANSMITTER SWITCH SETTINGS

telePilot or *telePendant* USE PDA SCREEN (Program the configuration switches 5, 6 & 7 to match the settings shown below).

MEMBRANE USE SW3 “C”

PENDANT, JLTX AND SLTX USE SW4 “D”

TRANSMITTER SWITCH SETTINGS:

**Position-5
OFF**

**Position -6
OFF**

**Position -7
ON**

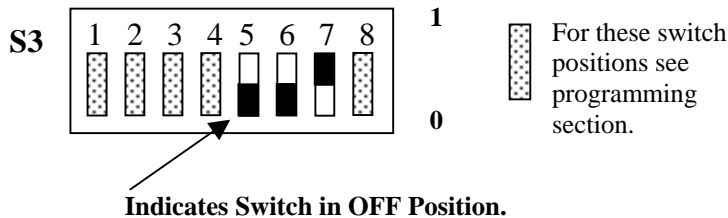

*NOTE: Hoist, Trolley and Bridge are listed here as traditional configurations, the installer may choose to define the motors differently.

Section 6 – Wiring (Continued)

**TABLE 2(F) 2-SPEED WIRING DIAGRAM.
P&H: 2-SPEED, 2-WINDINGS for HOIST;
STANDARD TROLLEY and BRIDGE**

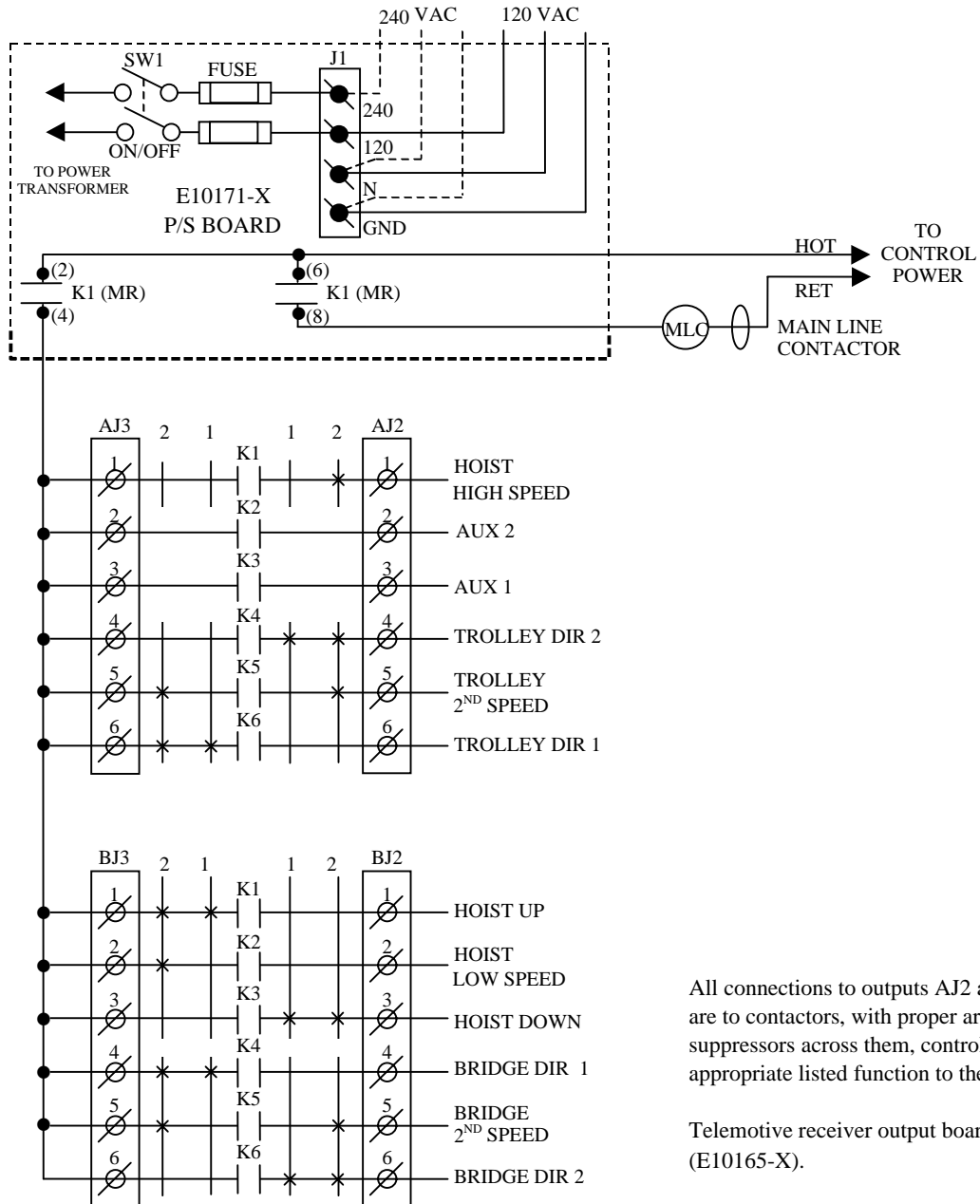

Section 6 – Wiring (Continued)

**TABLE 2(F) 2-SPEED PROGRAMMING DIAGRAM.
P&H: 2-SPEED, 2-WINDINGS for HOIST;
STANDARD TROLLEY and BRIDGE**

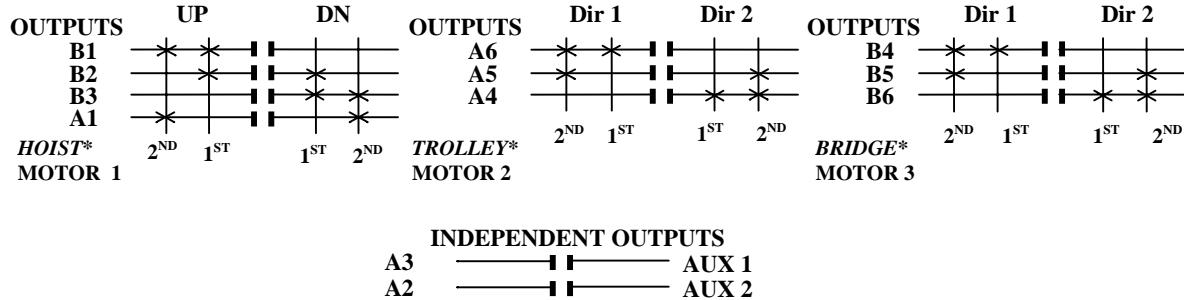

MOTOR 1 CONNECTIONS

- B1 *HOIST* UP
- B2 *HOIST* LOW SPEED
- B3 *HOIST* DOWN
- A1 *HOIST* HIGH SPEED

MOTOR 2 CONNECTIONS

- A6 *TROLLEY* DIR 1
- A5 *TROLLEY* 2ND SPEED
- A4 *TROLLEY* DIR 2

MOTOR 3 CONNECTIONS

- B4 *BRIDGE* DIR 1
- B5 *BRIDGE* 2ND SPEED
- B6 *BRIDGE* DIR 2

INDEPENDENT CONNECTIONS

- A3 AUX 1 (LATCHABLE S2-7)
- A2 AUX 2 (LATCHABLE S2-6)

TRANSMITTER SWITCH SETTINGS

telePilot or *telePendant* USE PDA SCREEN (Program the configuration switches 5, 6 & 7 to match the settings shown below).

MEMBRANE USE SW3 “C”

PENDANT, JLTX AND SLTX USE SW4 “D”

TRANSMITTER SWITCH SETTINGS:

- | | | |
|------------|-------------|-------------|
| Position-5 | Position -6 | Position -7 |
| ON | OFF | ON |

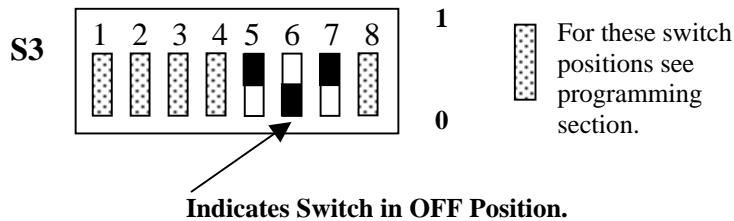

*NOTE: Hoist, Trolley and Bridge are listed here as traditional configurations, the installer may choose to define the motors differently.

Section 6 – Wiring (Continued)

**TABLE 2(G) 2-SPEED WIRING DIAGRAM.
DEMAG: 2-SPEED, 2-WINDINGS for HOIST;
STANDARD TROLLEY and BRIDGE**

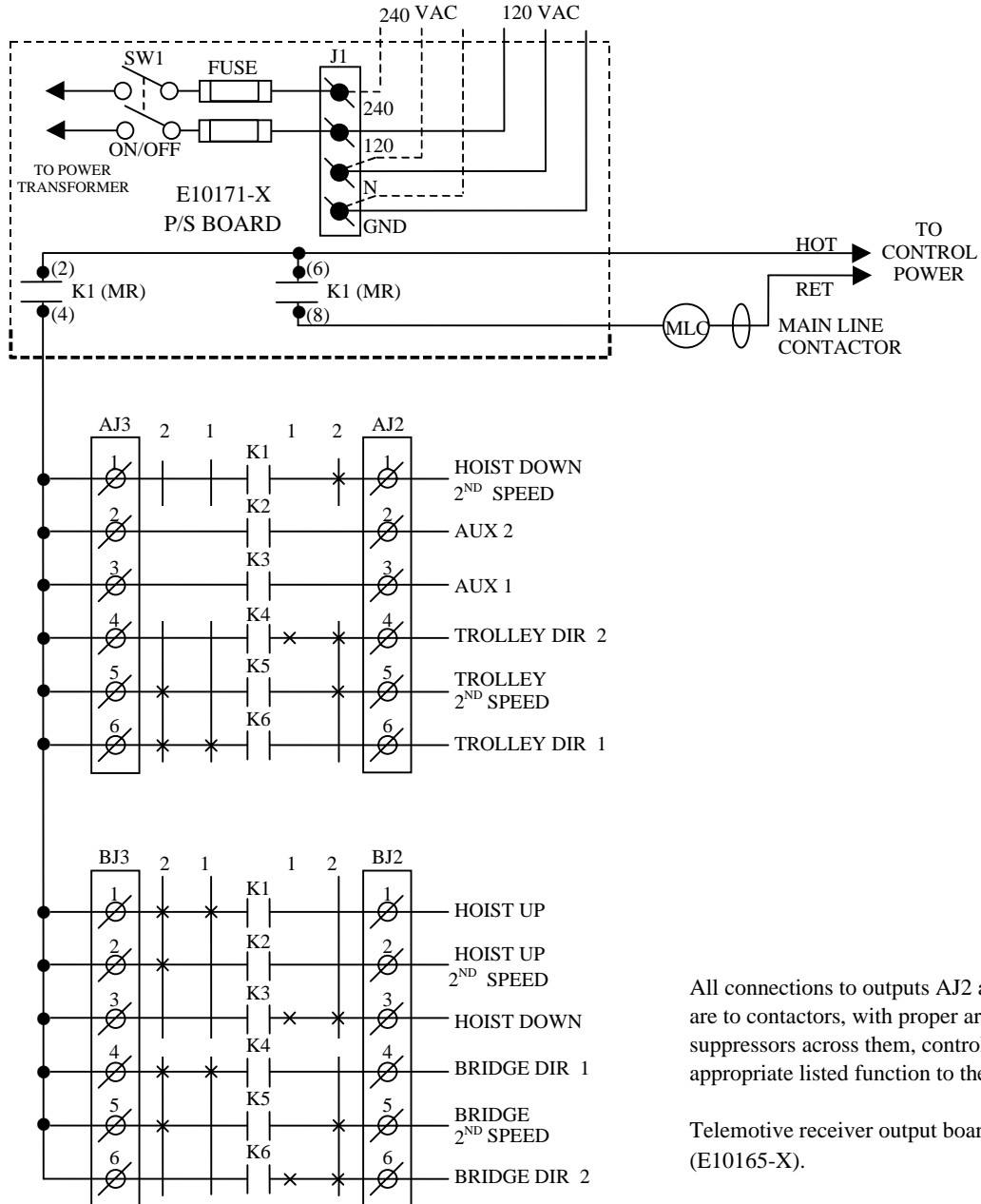

Section 6 – Wiring (Continued)

**TABLE 2(G) 2-SPEED PROGRAMMING DIAGRAM.
DEMAG: 2-SPEED, 2-WINDINGS for HOIST;
STANDARD TROLLEY and BRIDGE**

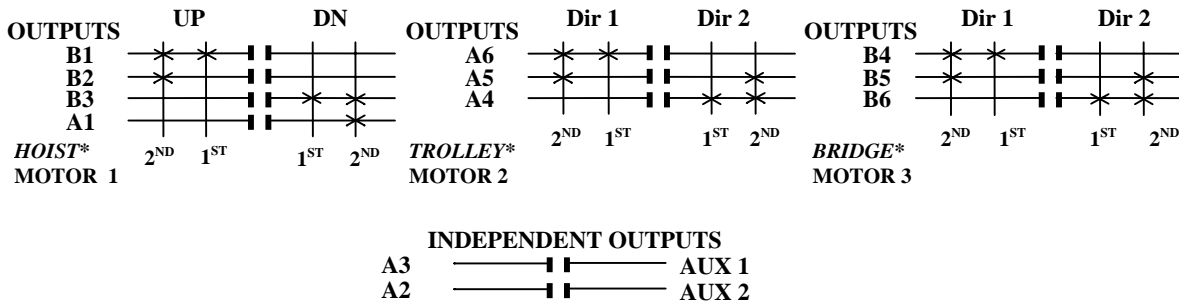

MOTOR 1 CONNECTIONS

B1 HOIST UP
B2 HOIST UP 2ND SPEED
B3 HOIST DOWN
A1 HOIST DOWN 2ND SPEED

MOTOR 2 CONNECTIONS

A6 TROLLEY DIR 1
A5 TROLLEY 2ND SPEED
A4 TROLLEY DIR 2

MOTOR 3 CONNECTIONS

B4 BRIDGE DIR 1
B5 BRIDGE 2ND SPEED
B6 BRIDGE DIR 2

INDEPENDENT CONNECTIONS

A3 AUX 1 (LATCHABLE S2-7)
A2 AUX 2 (LATCHABLE S2-6)

TRANSMITTER SWITCH SETTINGS

telePilot or telePendant USE PDA SCREEN (Program the configuration switches 5, 6 & 7 to match the settings shown below).

MEMBRANE USE SW3 “C”

PENDANT, JLTX AND SLTX USE SW4 “D”

TRANSMITTER SWITCH SETTINGS:

Position-5
OFF

Position -6
ON

Position -7
ON

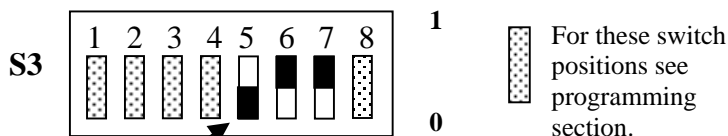

Indicates Switch in OFF Position.

*NOTE: Hoist, Trolley and Bridge are listed here as traditional configurations, the installer may choose to define the motors differently.

Section 6 – Wiring (Continued)

**TABLE 2(H) 2-SPEED WIRING DIAGRAM.
STANDARD 2-SPEED 4 MOTOR SYSTEM**

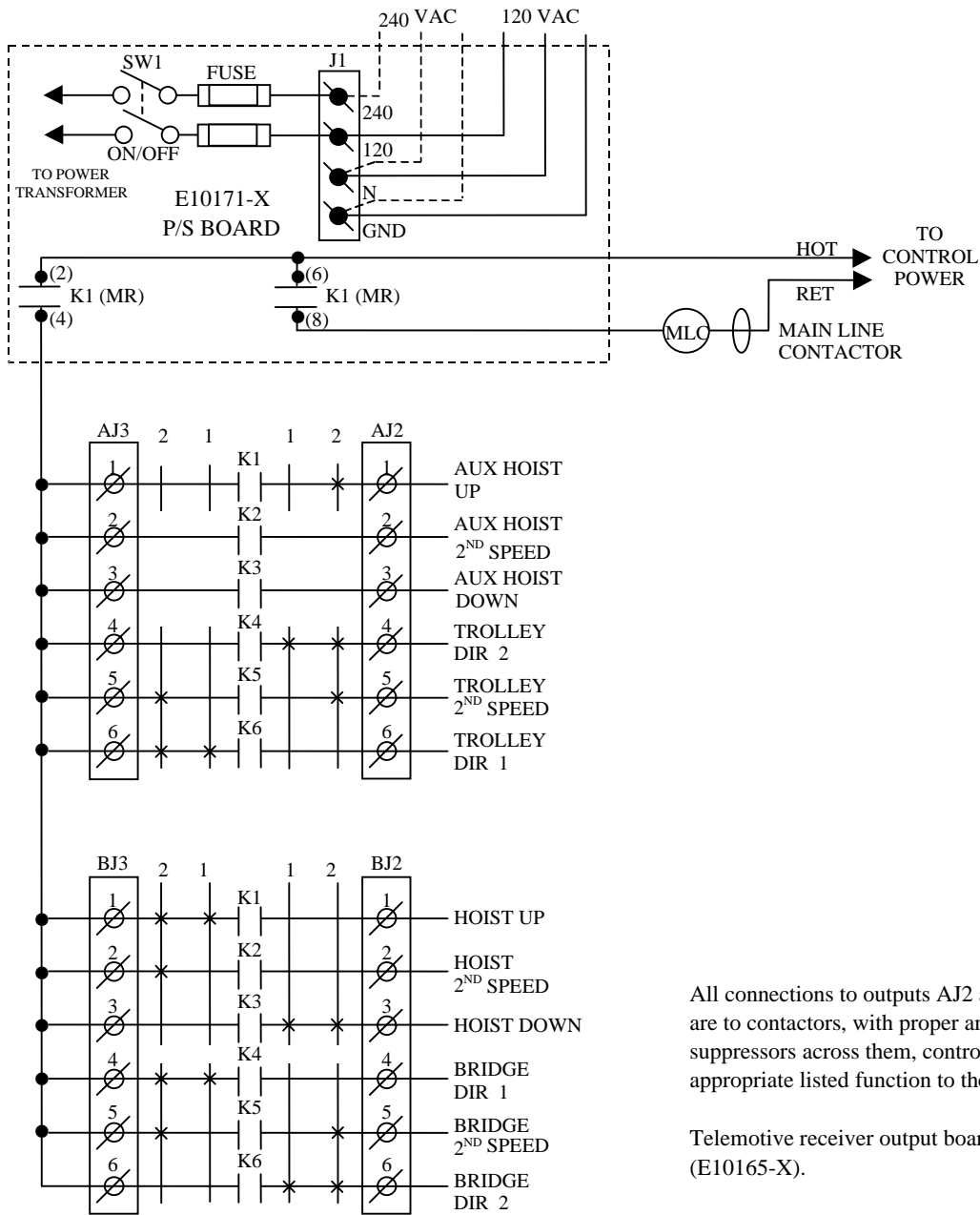

Section 6 – Wiring (Continued)

**TABLE 2(H) 2-SPEED PROGRAMMING DIAGRAM.
STANDARD 2-SPEED 4 MOTOR SYSTEM**

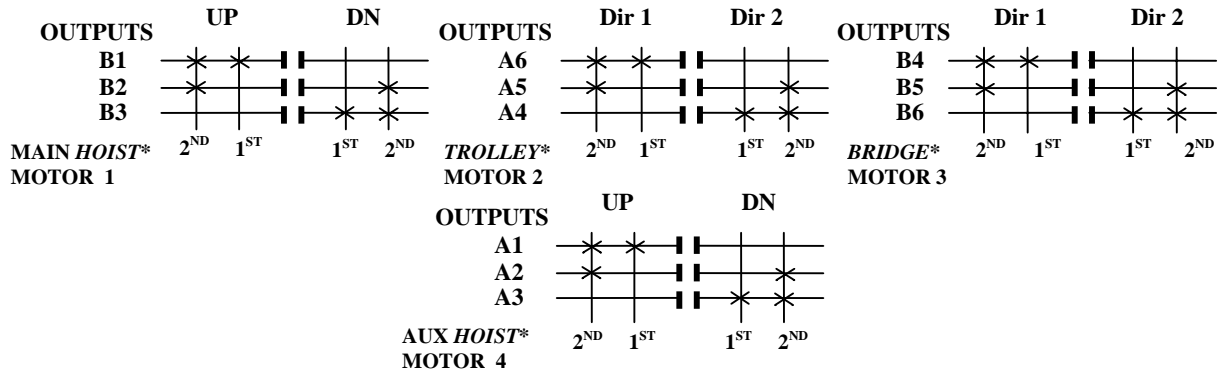

MOTOR 1 CONNECTIONS

B1 HOIST UP
B2 HOIST 2ND SPEED
B3 HOIST DOWN

MOTOR 2 CONNECTIONS

A6 TROLLEY DIR 1
A5 TROLLEY 2ND SPEED
A4 TROLLEY DIR 2

MOTOR 3 CONNECTIONS

B4 BRIDGE DIR 1
B5 BRIDGE 2ND SPEED
B6 BRIDGE DIR 2

MOTOR 4 CONNECTIONS

A1 AUX HOIST UP
A2 AUX HOIST 2ND SPEED
A3 AUX HOIST DOWN

NOTE

CHECK GOVERNMENTAL AND LOCAL REGULATIONS ON THE REQUIREMENTS OF HORNS OR ALARMS BEFORE USING THIS CONFIGURATION, AS THERE IS NOT A SEPARATE ALARM CONTROL.

TRANSMITTER SWITCH SETTINGS (This configuration does not apply to the Membrane transmitter).

telePilot or telePendant USE PDA SCREEN (Program the configuration switches 5, 6 and 7 to OFF. Under “Main/Aux” select the setting “Motor”).

PENDANT, JLTX AND SLTX TRANSMITTER SWITCH SW4 “D” SETTINGS:

Position-1	Position-2	Position-5	Position -6	Position -7
OFF	ON	OFF	OFF	OFF

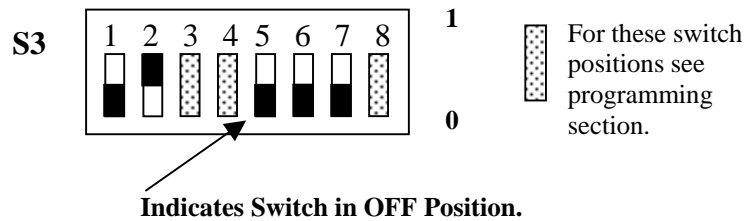

*NOTE: Hoist, Trolley and Bridge are listed here as traditional configurations, the installer may choose to define the motors differently.

Additional programming available:

Tandem operation, both Hoist and Aux Hoist being ON at the same time, can be disabled by un-checking the box marked “Tandem” on the telePilot and telePendant or turning on the Configuration Switch SW 4 “D” for the 10K Pendant, JLTX and SLTX.

Section 6 – Wiring (Continued)

**TABLE 2(I) 2-SPEED WIRING DIAGRAM.
STANDARD 2-SPEED 3, 4 & 5 MOTOR SYSTEM using SELECT**

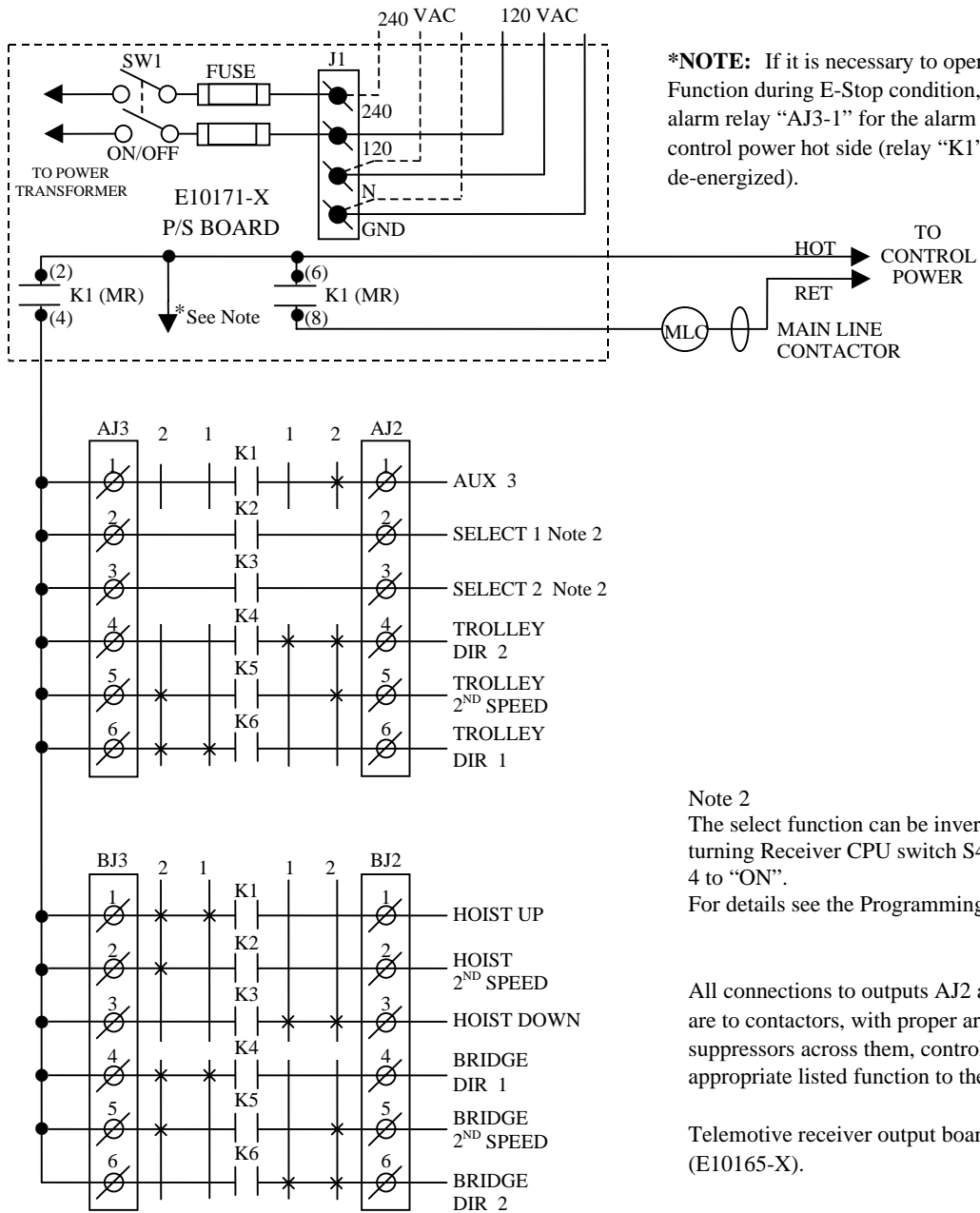

Section 6 – Wiring (Continued)

**TABLE 2(I) 2-SPEED PROGRAMMING DIAGRAM.
STANDARD 2-SPEED 3, 4 & 5 MOTOR SYSTEM using SELECT**

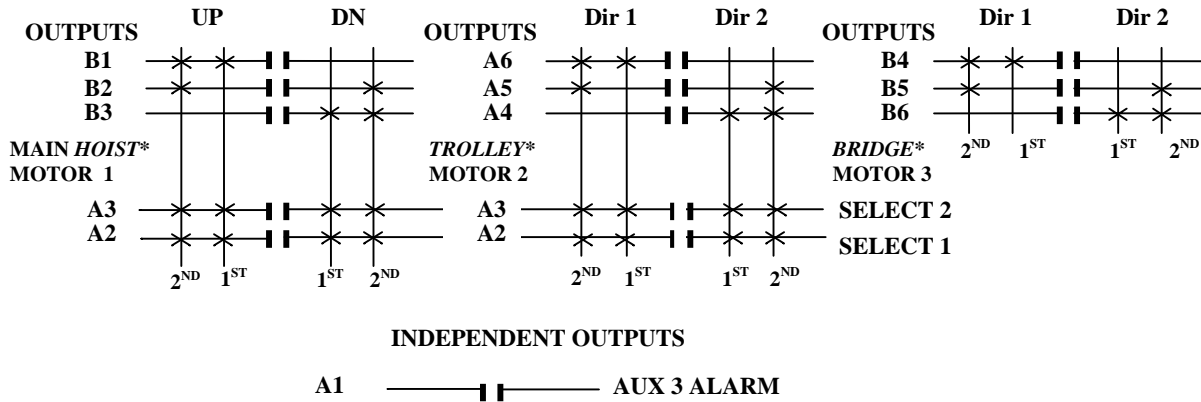

MOTOR 1 CONNECTIONS

B1 HOIST UP
B2 HOIST 2ND SPEED
B3 HOIST DOWN

MOTOR 2 CONNECTIONS

A6 TROLLEY DIR 1
A5 TROLLEY 2ND SPEED
A4 TROLLEY DIR 2

MOTOR 3 CONNECTIONS

B4 BRIDGE DIR 1
B5 BRIDGE 2ND SPEED
B6 BRIDGE DIR 2

INDEPENDENT CONNECTIONS

A3 SELECT 2

A2 SELECT 1

A1 AUX 3 ALARM

TRANSMITTER SWITCH SETTINGS (This configuration does not apply to the Membrane transmitter).

telePilot or telePendant USE PDA SCREEN (Program the configuration switches 5, 6 and 7 to OFF. Under “Main/Aux” select the word “Select”).

PENDANT, JLTx AND SLTx TRANSMITTER SWITCH SW4 “D” SETTINGS:

Position-1	Position-2	Position-5	Position -6	Position -7
ON	ON	OFF	OFF	OFF

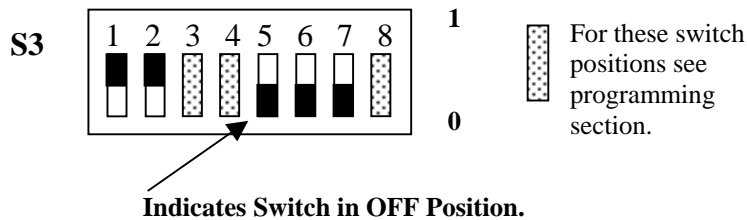

*NOTE: Hoist, Trolley and Bridge are listed here as traditional configurations, the installer may choose to define the motors differently.

Additional programming available:

The select function can be inverted by turning switch position 4 to ON (the Configuration Switch on the telePilot and telePendant or SW4 “D” for the 10K Pendant, JLTx and SLTx). Tandem select operation, both Select 1 and 2 ON at the same time, can be disabled by un-checking the box marked “Tandem” on the telePilot and telePendant or turning on the Configuration Switch SW 4 “D” for the 10K Pendant, JLTx and SLTx.

Section 7 – Programming

7-1. Access Codes.

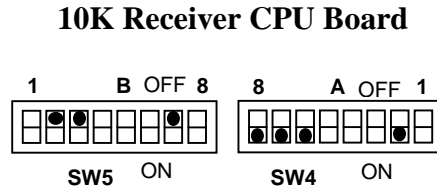
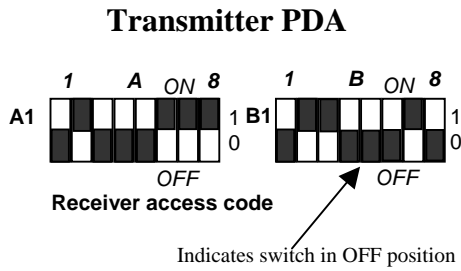

MODEL # -10KXXXXXXXXX
 S/N=XXXXXXXXXXXXXXXXXX
 ACCESS CODE SETTING
 1 A 8 1 B 8
 0 1 0 0 1 1 1 0 1 1 0 0 0 1 0
 FREQ : = AK01 J # = XXXXX

**Sample Membrane or Pendant Transmitter
 Access Code Label**
Sample access code only do not use

Figure 7-1. Access Code Setting.
(A dot on a switch position or a "1" in the label is an indication that the respective switch position should be ON).

WARNING

AFTER CHANGING THE ACCESS CODES ON THE TRANSMITTER, TEST THE UNIT BY TURNING IT ON AND OFF NEAR THE APPROPRIATE RECEIVER. IF THE RECEIVER DOES NOT RESPOND, DO NOT ACTIVATE A FUNCTION BUTTON! THE TRANSMITTER MAY HAVE THE WRONG ACCESS CODE, WHICH COULD MOVE ANOTHER CRANE. RE-CHECK THE ACCESS CODE IN THE TRANSMITTER AND RETEST. FAILURE TO FOLLOW THIS WARNING COULD RESULT IN SERIOUS INJURY OR DEATH AND DAMAGE TO EQUIPMENT.

7-1.1. Programming Access Codes.

The access code is set at the factory and should not be changed unless absolutely necessary. The programming in the receiver(s) must match the transmitter. If you are reprogramming a spare or new transmitter make sure the other transmitter is securely taken out of service.

WARNING

TWO OPERATIONAL TRANSMITTERS WITH THE SAME ACCESS CODES OPERATING AT THE SAME TIME IS A DEFINITE SAFETY HAZARD. FAILURE TO FOLLOW THIS WARNING COULD RESULT IN SERIOUS INJURY OR DEATH AND DAMAGE TO EQUIPMENT.

WARNING

THE ACCESS CODES IN THE RECEIVER ARE UNIQUE AND FACTORY PRESET. DO NOT CHANGE THESE ACCESS CODES UNLESS YOU ARE REPLACING AN EXISTING RECEIVER AND ITS ACCESS CODE. CHANGING THIS CODE COULD MAKE IT COMMON WITH ANOTHER RECEIVER ACCESS CODE, WHICH COULD MOVE ANOTHER CRANE. NO TWO SYSTEMS IN ANY LOCATION SHOULD EVER HAVE THE SAME ACCESS CODES INDEPENDENT OF FREQUENCY. FAILURE TO FOLLOW THIS WARNING COULD RESULT IN SERIOUS INJURY OR DEATH AND DAMAGE TO EQUIPMENT.

For detailed instructions on setting parameters including access codes see Section 7.1.2.

Section 7 – Programming (Continued)

7-1.2. Receiver Access Code Setting.

The access code is preset at the factory and should not be changed unless absolutely necessary. The access code switches are labeled “B” and “A”. See Figure 8-1. Receiver Layout for switch location.

The programming in the receiver(s) must match the transmitter. If looking at the PDA or documentation sent with the transmitter, take note that positions “A” and “B” number from the left 1 through 8.

NOTE

IN EVENT OF REPROGRAMMING OF ACCESS CODES IS REQUIRED, TAKE SPECIAL CARE TO CORRECTLY LOCATE ACCESS CODE SWITCHES A AND B. LOOK FOR THE LABELS A AND B ON THE PRINTED CIRCUIT BOARD NEAR THE RESPECTIVE SWITCHES. DETERMINE THEIR ORIENTATION. THE SWITCHES MAY NUMBER FROM LEFT TO RIGHT OR RIGHT TO LEFT. LOOK FOR THE NUMBERING ON THE SWITCHES. MATCH ACCESS CODES A1, A2, --- B1, B2 ETC.

NOTE

FOR THE RECEIVER. DO NOT USE A PENCIL TO TOGGLE THE SWITCHES. THE LOOSE GRAPHITE FROM THE PENCIL CAN DAMAGE THE SWITCH.

After changing the access code, test the receiver (s) with a matching transmitter. (If the red LED DS9 comes ON in the receiver the code does not match, recheck the access code settings).

7-2. Receiver Frequency Programming.

The receiver is equipped with a frequency synthesizer that allows frequencies to be easily changed without retuning. Normally the frequency does not have to be changed; the unit comes programmed to a specific frequency listed on the Frequency and Access Code Label on the receiver door.

7-2.1. RF Receiver Board Frequency Synthesizer.

Located in the receiver is the RF Receiver Board. The circuitry on this board contains a digital

oscillator and synthesizer that are controlled by a microprocessor. This eliminates the need for specific crystals to change frequencies. The onboard microprocessor automatically retunes the RF receiver when the channel is changed; no retuning or any other adjustment is required.

7-2.2. Reading The Channel (Frequency).

Using Figure 8-1. Receiver Layout. locate the RF Receiver Board. Locate the Top Viewing Window (see Figure 7-2. RF Receiver Board). Looking in the Top Viewing Window close to the edge of the board is a red LED that, with the power to the receiver ON, is constantly lit. This indicates the RF Receiver Board is ON and working. Looking farther back into the Top Viewing window there are two flashing LEDs, a red one and a green one. These LEDs flash repeatedly and slowly so allow some time to see them flash. These flashing LEDs indicate the channel (frequency) the unit is receiving.

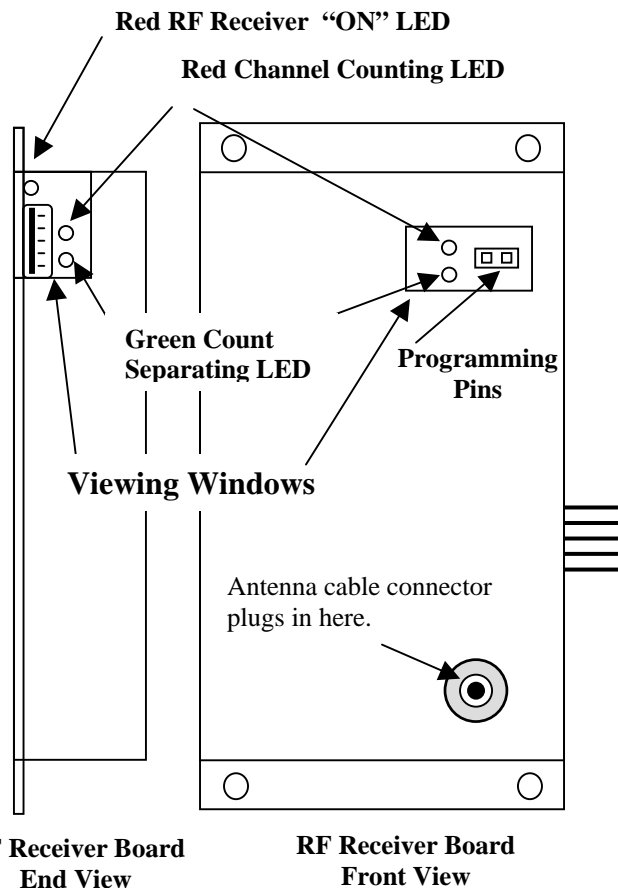

Figure 7-2. E13157-S
Synthesized RF Receiver Board.

Section 7 – Programming (Continued)

The counting is done in two digits, where the two digits indicate channel number. The red LED counts (flashes) the channel number in two digits; the green LED indicates (flashes) the spacing and position of the counted digit. The ones digit is counted first and then the tens digit with one green LED flash indicating the beginning of the count of ones digit and two green LED flashes indicating the beginning of the tens digit count.

An example is if the channel is AK04 the channel number is 04. The ones digit is 4 (four red flashes) and the second is zero (no red flash).

The repeated sequence for reading channel 4 is: Long pause, green, red, red, red, red, short pause green, green, (no red flash, zero).

The repeated sequence for reading channel 12 is: Long pause, green, red, red, short pause, green, green, red.

Other examples are (equals count):

- AK01 (1): green, red, short pause, green, green.
- AK02 (2): green, red, red, short pause, green, green.
- AK05 (5): green, red, red, red, red, red, short pause, green, green.
- AK07 (7): green, red, red, red, red, red, red, red, short pause, green, green.
- AK10 (10): green, short pause, green, green, red.
- AK11 (11): green, red, short pause, green, green, red.
- AK14 (14): green, red, red, red, red, short pause, green, green, red.
- AK20 (20): green, green, green, red, red.
- AKA06 (27): green, red, red, red, red, red, red, red, short pause, green, green, red, red.

Channel and Frequency Designations by Count.

Indicator Count	Channel Designator	Actual Frequency
1.	AK01	439.8 MHz
2.	AK02	439.6 MHz
3.	AK03	439.4 MHz
4.	AK04	439.2 MHz
5.	AK05	439.0 MHz
6.	AK06	438.8 MHz
7.	AK07	438.6 MHz
8.	AK08	438.4 MHz
9.	AK09	438.2 MHz
10.	AK10	438.0 MHz
11.	AK11	437.8 MHz

12.	AK12	437.6 MHz
13.	AK13	437.4 MHz
14.	AK14	437.2 MHz
15.	AK15	437.0 MHz
16.	AK16	436.8 MHz
17.	AK17	436.6 MHz
18.	AK18	436.4 MHz
19.	AK19	436.2 MHz
20.	AK20	436.0 MHz
21.	AKA00	433.125 MHz
22.	AKA01	433.325 MHz
23.	AKA02	433.525 MHz
24.	AKA03	433.725 MHz
25.	AKA04	433.925 MHz
26.	AKA05	434.125 MHz
27.	AKA06	434.325 MHz
28.	AKA07	434.525 MHz
29.	AKA08	434.725 MHz

7-2.3. Reprogramming The Synthesizer.

Locate the Programming Pins by looking at the side of the RF Receiver Board. To reprogram the synthesizer a small metal tipped blade screwdriver or other tool is necessary to short the two pins together to put in the reprogramming mode.

Having located the programming pins and while watching the flashing red Channel Counting LED, short the programming pins together and keep them shorted. (Do not be concerned while shorting these pins together about touching the metal RF Receiver shield with the shorting tool, it will not cause any damage to the circuitry).

When the Programming Pins are shorted the RF Receiver will go into the programming mode. KEEP THE PINS SHORTED UNTIL THE PROGRAMMING IS COMPLETE. The green and red channel indicating LEDs will complete one last channel indication and then only the red LED Channel Counting LED will start to flash. The synthesizer will start programming from channel AK01 and count up in sequence for each channel with a pause in between each channel count. A full count of flashes will be made for each channel with a short pause in between each channel counts by the red Channel Counting LED. The channel counts will increase by one channel after each pause. Keep track of the individual channel counts to determine which frequency the synthesizer is on.

Section 7 – Programming (Continued)

The flashing sequence is as follows: one flash (AK01) short pause, two flashes (AK02), short pause, three flashes (AK03), etc. For channel numbers ten and greater the red LED will still count these out completely, so for channel AK12 there will be twelve flashes. The green LED DOES NOT flash during channel programming.

When you have reached the correct count for the channel desired, remove the short from the shorting pins immediately. Wait a minute for the RF Receiver to automatically retune itself and the green and red channel indicating light should then start to flash indicating the current channel number.

Check the channel count to verify that the RF Receiver is programmed to the desired channel. (If you have passed the channel number desired wait a minute for the green LED to flash and re-short the pins, the count will begin again from channel AK01).

Multibox.

7-2.4. Multibox Operation.



WARNING

IF YOUR UNIT WAS NOT ORDERED WITH MULTIBOX DO NOT ATTEMPT TO PROGRAM MULTIBOX IN THE FIELD. TELEMOTIVE MUST COORDINATE ACCESS CODE ASSIGNMENTS WITH THE TRANSMITTERS PRIOR TO ENABLING MULTIBOX. PLEASE CONTACT TELEMOTIVE IF YOU NEED TO ADD MULTIBOX. FAILURE TO FOLLOW THIS WARNING COULD RESULT IN SERIOUS INJURY OR DEATH AND DAMAGE TO EQUIPMENT.



WARNING

IF YOUR UNIT HAS MULTIBOX DO NOT ATTEMPT TO PROGRAM ADDITIONAL TRANSMITTERS IN THE FIELD. TELEMOTIVE MUST COORDINATE ACCESS CODE ASSIGNMENTS WITH THE NEW TRANSMITTERS PRIOR TO EXPANDING MULTIBOX. PLEASE CONTACT TELEMOTIVE IF YOU NEED TO ADD ADDITIONAL TRANSMITTERS. FAILURE TO FOLLOW THIS WARNING COULD RESULT IN SERIOUS INJURY OR DEATH AND DAMAGE TO EQUIPMENT.

The receiver has Multibox capability that allows up to 8 transmitters to access a single system. Only one transmitter may control the receiver at a given time. Access is on a first come first serve basis. Once a transmitter has gained control, another transmitter may not access the receiver until the controlling transmitter relinquishes control by transmitting an OFF command to the receiver or the receiver times out due to inactivity.

The first transmitter to send an ON command after the receiver has been released will then gain control of the receiver. The number of transmitters (1-8) allowed to control the receiver is selectable on the Receiver.

NOTE

THE DESIRED MULTIBOX TRANSMITTERS MUST HAVE CONSECUTIVE ACCESS CODES BEGINNING FROM THE FIRST ACCESS CODE.

See Table 7-1. Multibox Switch Settings below for appropriate settings for both the transmitters and receiver.

Section 7 – Programming (Continued)

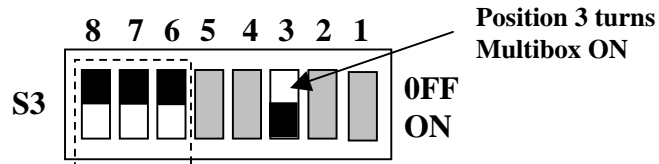

Figure 7-3. S3 Receiver Multibox Dip Switches

Table 7-1. Multibox Switch Settings.

Receiver Rx Status Word S1 Switch Settings			Maximum of Transmitters	Transmitter (Membrane and Pendant only). Access Code Switch Settings
S3-8	S3-7	S3-6		
0	0	0	1	First Access Code
1	0	0	2	First Access Code + 1 bit
0	1	0	3	First Access Code + 2 bits
1	1	0	4	First Access Code + 3 bits
0	0	1	5	First Access Code + 4 bits
1	0	1	6	First Access Code + 5 bits
0	1	1	7	First Access Code + 6 bits
1	1	1	8	First Access Code + 7 bits

Section 7 – Programming (Continued)

7-3. Receiver Programming Options Summary Diagram.

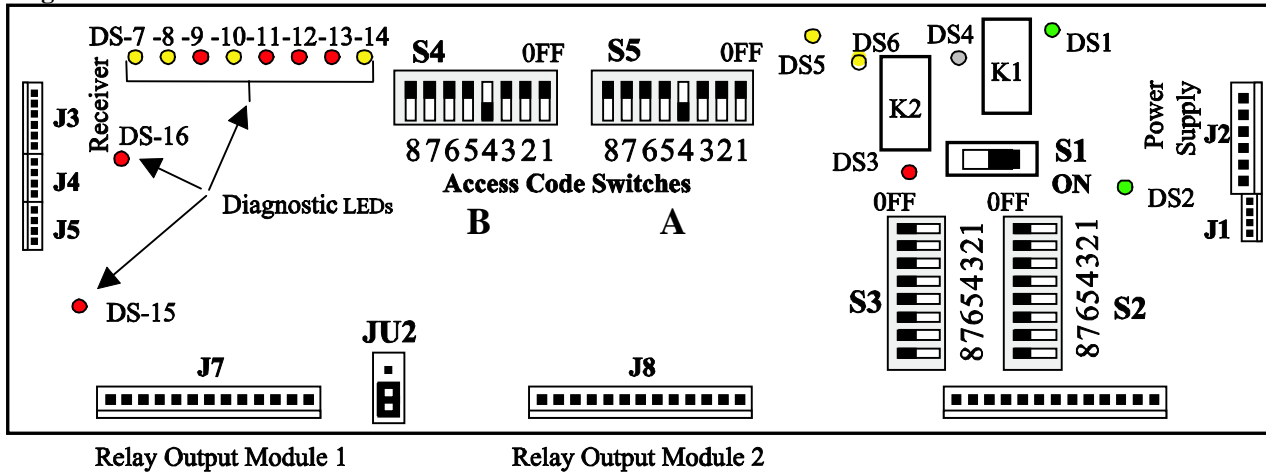

The receiver CPU board is shown above. Refer to paragraphs below for switch and jumper settings.

S1 Switch Settings

Controls power to the Master Relay. With the switch set to ON power is on to all relays. Move the switch to OFF for circuit testing without activating external controls.

S2 Switch Settings

- S2-1 Auto Alarm
- OFF Auto Alarm Disabled
- ON Auto Alarm Enabled
- S2-2 EMS Alarm
- OFF EMS Alarm Disabled
- ON EMS Alarm Enabled
- S2-3 Master Control Relay
- OFF MCR Disabled
- ON MCR Enabled
- S2-4 Not used
- S2-5 Not used
- S2-6, 7 & 8 Aux Relay Latching*
- OFF Latching Disabled
- ON Latching Enabled

* See the specific configuration for your application for details on which switch controls which relay.

JU2 Jumper Settings

In the lower position (the position shown) the alarm relay is disabled after an E-Stop shutdown. This is the factory default setting. Moving it to the upper position

enables it. See the appropriate Programming Diagram for the Alarm Relay Location.

S3 Switch Settings

- S3-1 Not used
- S3-2 Time Out Timer
- OFF Time Out Enabled
- ON Time Out Disabled
- S3-3 Multibox
- OFF Multibox Disabled
- ON Multibox Enabled
- S3-4 and -5 Not used

S3 Multibox Setting (Only with S3-3 On)

<u>S3-6</u>	<u>S3-7</u>	<u>S3-8</u>	TXS	Access Code
OFF	OFF	OFF	1	Base Address
OFF	OFF	ON	2	Base Address +1
OFF	ON	OFF	3	Base Address +2
OFF	ON	ON	4	Base Address +3

For more Base Address' please contact Telemotive.

Section 7 – Programming (Continued)

System Functions Selection

Special programming exists to allow some of the Aux relays to be dedicated for special system functions. Setting certain dip switches on the CPU Board enables this programming.

Auto Alarm and EMS Alarm

You can have either one of these functions or both. The use of either one of these two functions dedicates one specific control relay to operate an external alarm. An external alarm (not supplied) needs to be connected to this relay.

Auto Alarm (S2-1)

Description

Gives about 5 seconds of alarm when the transmitter is first turned on.

To Enable

Connect an external alarm. Move dip switch S2-1 on the CPU Board to the ON position.

Emergency Stop (EMS) Alarm (S2-2)

Description

Gives about 5 seconds of alarm when the Emergency Stop (EMS) is activated on the transmitter.

To Enable

Connect an external alarm. Move dip switch S2-2 on the CPU Board to the ON position and set jumper JU2 to the upper position. (As a safety measure during EMS shutdown all control lines to relays are disabled. Jumper JU2 facilitates bypassing the EMS shutdown to the Alarm Relay so it can be activated during an EMS shutdown.)

Master Control Relay (MCR) Monitoring Disable (S2-3)

Disables the contact monitoring of the MCR. Used for special diagnostic purposes only. In normal operation switch S2-3 should be set to OFF. Set to ON to disable contact monitoring of MCR.

Auxiliary Function Relay Latching (S2-6, -7 and -8)

Enables the appropriate auxiliary function relay to operate in a latched mode, on or off, rather than as a momentary contact. Which function is latchable and which relay is latched depends on the particular transmitter used.

Switch S2, positions 6 through 8 on the CPU Board each enable a separate relay to be latched when turned on. If your transmitter does not have a document describing these functions, the easiest way to determine correlation

of transmitter function, relay position and dip switch position, is to try various dip switch setting and see which relays are latched and which transmitter controls them. Make sure all three switch positions are off, turn S2-6, S2-7 and S2-8 on separately and note which relay is affected by the appropriate LED indication.



WARNING

MAKE SURE S1 ON RECEIVER CPU BOARD MASTER CONTROL RELAY (MCR) IS TURNED OFF BEFORE ATTEMPTING SETTING OF ANY PROGRAMMING SWITCH TO PREVENT ACTIVATION OF EXTERNAL CIRCUITRY. FAILURE TO FOLLOW THIS WARNING COULD RESULT IN SERIOUS INJURY OR DEATH AND DAMAGE TO EQUIPMENT.

Time Out Timer Enable (S3-2)

The receiver contains a time out timer. If a receiver once turned on by a transmitter does not receive a signal from a transmitter for a period of 15 minutes the receiver shuts down. Setting S3-2 to ON disables this function.

Section 8 – Servicing

Figure 8-1. Receiver Layout

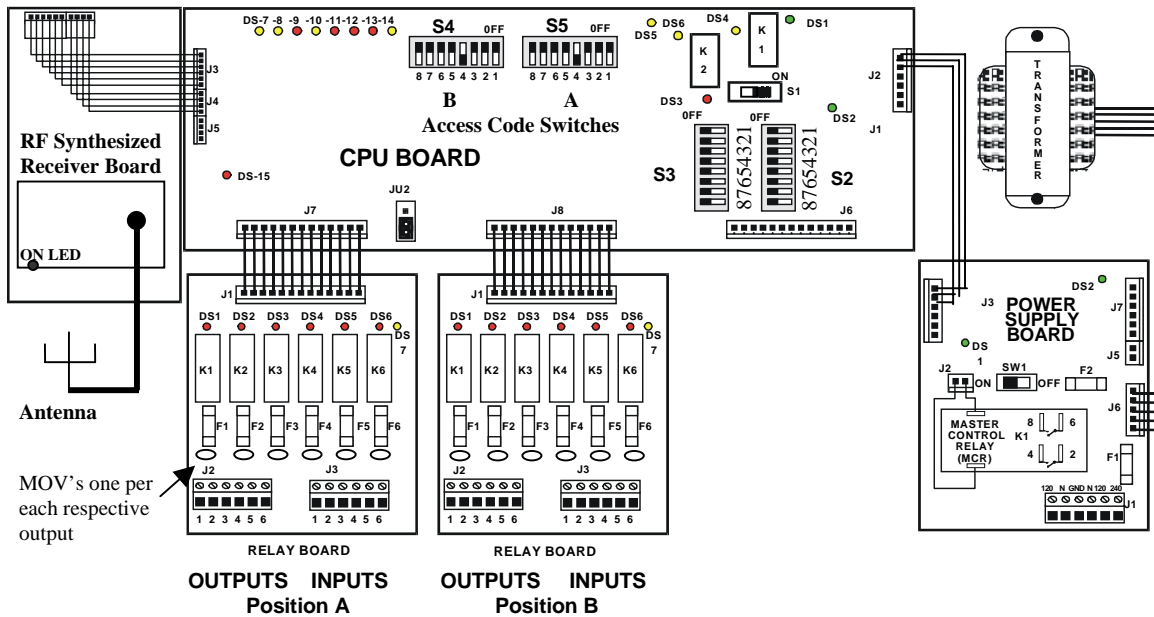

NOTE

IF THE SYSTEM STOPS WORKING, CHECK THE RED INDICATOR ON THE TRANSMITTER. IF IT DOES NOT COME ON WITH PUSHING THE ON BUTTON OR A WEAK BATTERY IS INDICATED ON THE TRANSMITTER REPLACE THE TRANSMITTER BATTERIES.

Table 8-1. Receiver Diagnostic LED Functions. (See Figure 8-1. Receiver Layout for LED locations).

LED	COLOR	FUNCTION
DS1	Green	Monitors the 12 VDC power to the Microprocessor Control Board. Normally ON. If 12 VDC power is present then LED is illuminated. LED is off if 12 VDC power is not present. Check power supply, fuses and if power is on to receiver.
DS2	Green	Monitors + 5 VDC regulated voltage. Normally ON. If 5 VDC power is present then LED is illuminated. LED is off if 5 VDC power is not present. Check connectors, the +5 VDC regulator, or for shorts on the board.
DS3	Red	Monitors closure of the Master Control Relay (MCR) relay (K1). LED will be illuminated when the MCR relay has been enabled by an ON command received from the Transmitter Unit. LED will extinguish, when an OFF command has been transmitted, an EMS condition is present, or SW1 is set to 0. The MCR controls the 12 VDC power to the Master Relay on the Power Supply Board.
DS4	Yellow	Monitors closure of the Security Relay output (K2). The LED will be illuminated when the Security Relay has been enabled by an ON command received from the Transmitter Unit. LED will extinguish when an OFF command is transmitted, or an EMS condition is present. The Security Relay controls the 12 VDC power to the MCR relay (K2) and the power to the coils of the control relays (K1 through K8) on the Relay Output Modules.

Section 8 – Servicing (Continued)

LED	COLOR	FUNCTION
DS5	Yellow	<p>Monitors the AC bias pump line for the Security Relay (K2).</p> <p>LED will flash only when the Receiver has been enabled by an ON command.</p> <p>The Security Relay is enabled by an AC signal generated by the slave microcomputer. The AC signal is capacitively isolated from the slave microcomputer to help prevent the Security Relay from being latched ON if the slave microcomputer fails. LED will not be illuminated when an OFF command has been sent or an EMS condition is present.</p>
DS6	Yellow	<p>Monitors AC bias pump line for the Master Control Relay (K1).</p> <p>LED will flash only when the Receiver Interface Control Module has been enabled by an ON command.</p> <p>The Master Control Relay (K1) is enabled by an AC signal generated by the slave microcomputer. The AC signal is capacitively isolated from the slave microcomputer to help prevent the MCR from being latched ON if the slave microcomputer fails. The LED will not be illuminated when an OFF command has been sent or is in an EMS mode.</p>
DS7	Yellow	<p>Monitors data synchronization. (Flashes when a properly formatted data signal is received from the transmitter).</p> <p>This LED will flash rapidly when data is transmitted. The LED can be used with DS9 to analyze incoming data. If DS9 is illuminated or flashing when DS7 also is flashing, another Transmitter Unit on the same frequency may be present. This is normal. As more Transmitter Units operated on the same frequency, LED will flash brighter and more often.</p>
DS8	Yellow	<p>Monitors continuity between receiver and CPU modules.</p> <p>Normally ON.</p> <p>Off indicates a malfunctioning receiver.</p>
DS9 Wrong Access Code Check first!	Red	<p>Monitors received data errors.</p> <p>Normally OFF.</p> <p>A flashing LED during data transmission may indicate interference of the received data. If LED is illuminated continuously when data is transmitted and the system will not respond the Access Code of the Receiver and Transmitter Units may not match. If LED is illuminated when data is not transmitted, another Transmitter Unit may be present on the same frequency with a different Access Code. The presence of activity on this LED does not necessarily indicate a problem. It should be used with other indicators in analyzing system status.</p>
DS10	Yellow	<p>Monitors system activity.</p> <p>Normally FLASHING.</p> <p>If not flashing the microprocessor is dead.</p>
DS11	Red	<p>Monitors the ON command from the Transmitter.</p> <p>LED will flash when an ON command is being received from the Transmitter.</p> <p>While pushing the ON button on the Transmitter this should light.</p>
DS12	Red	<p>Monitors the OFF command from the Transmitter.</p> <p>LED will flash when an OFF command is being received from the Transmitter Unit.</p> <p>While pushing the OFF button on the Transmitter this should light.</p>

Section 8 – Servicing (Continued)

LED	COLOR	FUNCTION
DS13	Red	<p>Monitors EMS condition.</p> <p>Normally OFF.</p> <p>LED will flash when an EMS command is transmitted and illuminate continuously when the EMS condition is in effect. An EMS condition may be created when an EMS command is transmitted or when a failure mode is detected by the slave microcomputer. If both DS11 and DS13 are illuminated, a contact monitoring error has been detected. If both DS9 and DS13 are illuminated, the incoming data on the ICC bus has been corrupted.</p>
DS14	Yellow	<p>Monitors the AC activity for the Security Relay (K1).</p> <p>Normally ON.</p> <p>If the system is ON and the light is not lit there is a serious microprocessor error.</p>
DS15	Red	<p>Monitors the watchdog timer.</p> <p>Normally OFF.</p> <p>The LED will illuminate momentarily when power is applied to or removed from the system. If the LED is continuously flashing or on, the computer is not working properly. If LED is illuminated constantly (no flashing), the +5 VDC is probably too low. This could be caused by shorts on the board or by a defective voltage regulator. If the LED flashes at a constant rate, the microcomputer chip or EPROM may be defective.</p>
DS16		Not used.

RF Receiver Module

LED	COLOR	FUNCTION
RF Receiver ON LED	Red	<p>Power is on to the RF Receiver.</p> <p>Normally ON.</p> <p>Monitors power to the RF Receiver Board. If the main receiver is ON and the RF Receiver ON LED is OFF. Check to see if the RF Receiver Board is properly plugged in to the main board.</p>

Power Supply Module

LED	COLOR	FUNCTION
DS1	Green	<p>Monitors unregulated 12 VDC.</p> <p>Normally ON.</p> <p>Check fuse, wiring to unit and AC power to unit.</p>
DS2	Green	<p>Monitors regulated 12 VDC.</p> <p>Normally ON.</p> <p>DS2 off and DS1 on, check for shorts on regulated output or blown regulator. Disconnect power supply connector to computer control board, if DS2 light comes back on there is a short on one of the other boards.</p>

Section 8 – Servicing (Continued)

Relay and Output Modules

LED	COLOR	FUNCTION
DS1-6 or DS1-8	Green	Monitors the power to the relay coil or switching device. Normally OFF unless command is sent to turn ON. The numbers of LEDs depend on the number of functions per board. LEDs are located next to the relay or switch they control. Ground is switched to the relay coil or switch to turn it on; this also turns on the light.
DS7 or DS9	Green	Monitors 12 VDC to the relay or output module. Normally ON. LED off indicates no power to the relay or output module.

Section 9 - Spare Parts

RECEIVER PART NUMBER	DESCRIPTION
E13151-5XA	UHF RECEIVER MODULE
E10163-1	CPU EPROM (10K12 SINGLE BOX) System ROM FW2832-0
E10163-5	CPU EPROM (10K12 MULTI-BOX) System ROM FW2833-0
E10163-3	CPU EPROM (10K16/24 SINGLE BOX) System ROM FW2834-0
E10163-4	CPU EPROM (10K16/24 MULTI-BOX) System ROM FW2835-0
E10171-0	POWER SUPPLY MODULE
E10165-0	OUTPUT RELAY MODULE (6 RELAYS)
E10112-0	OUTPUT RELAY MODULE (8 RELAYS)
K2116-1	RELAY DPST-N.O. 25A, 12VDC COIL (POWER SUPPLY BOARD)
K1304-0	RELAY SPDT, 16A, 12VDC COIL (OUTPUT BOARD)
F2711-0	FUSE, 10A, 250V, 5X20mm SLO-BLO
F2711-1	FUSE, 1.0A, 250V, 5X20mm SLO-BLO
F2711-3	FUSE, 0.3A, 250V, 5X20mm SLO-BLO
W1098-2	JUMPER, INSULATED, 2-CIRCUITS
W1098-4	JUMPER, INSULATED, 4-CIRCUITS
AN100-0	ANTENNA
E2028-2	OPTIONAL REMOTE EXTERNAL ANTENNA KIT