

TELEMOTIVE

telePilot[™]

TRANSMITTERS

TX12M-1, -2

RADIO

CONTROL

SYSTEM

telePilot Programming is
found on page 62.



MAGNETEK
UNCOMMON POWER

Material Handling Group

N49 W13650 Campbell Drive
Menomonee Falls, WI 53051
Phone: 800-288-8178 Fax: 262-783-3510
Website: www.telemotive.com

This page intentionally left blank.

Table of Contents

1-	Service Information	3
2-	Radio Controlled Crane Safety	4
	1. Warnings, Cautions and Notes	4
	2. Critical Installation Considerations	4
	3. General	5
	4. Persons Authorized To Operate Radio Controlled Cranes	5
	5. Training Checklist For Crane Operators	5
	6. Operating Area	6
	7. Transmitter Unit	6
	8. Operating The Crane	6
	9. Boarding The Crane	7
	10. Crane Maintenance and Repair	7
	11. Using The Crane As A Work Platform	8
	12. Condition Of The Radio Controlled Crane	8
	13. Batteries	9
3-	General System Information	11
	1. General System Information	11
	2. TMS Low Power Signaling	11
	3. Channel Designations	11
	4. System Specifications	11
	5. Transmitter Unit	11
	6. Receiver Unit	12
4-	Installation Procedure	13
	1. Pre-Installation Considerations	13
	2. Receiver Unit Mounting Location Considerations	13
	3. Antenna Mounting Considerations	13
	4. Line Input Considerations	13
	5. Wiring Considerations	13
	6. Receiver Receiver/Equipment Interface Considerations	14
	7. Receiver Unit Cabinet Mounting	14
	8. Receiver Installation	14
	Figure 4-1. Input Power Connections	15
	Figure 4-2A. Receiver Mounting Details Horizontal with Mounting Brackets	15
	Figure 4-2B. Receiver Mounting Details Vertical with Mounting Brackets	16
5-	Operation	17
	Figure 5-1. telePilot, Pendant and Membrane Transmitters	17
	1. Transmitter Buttons	17
	2. ON/OFF LED Indicator	18
	3. Low Battery Indicator	18
	4. Optional 4th Motor Select Indicator	18
	5. Operation	18
	6. Additional telePilot Transmitter Operational Features	19
	7. Battery Replacement	18
6-	Wiring Diagram	23
	1. Wiring Diagrams	23
	2. Installation	23
	3. Alarms and Horns	23
	4. Single-Speed Pendant Transmitter Wiring	23
	5. Two-Speed Pendant Transmitter Wiring	23
	6. Relay Sequencing	23
	7. Alarm After E-STOP	23
	8. Connecting Outputs to Drives	23
	9. Optional Transfer Switch Wiring Configurations	24
	Figure 6-1. Legend	24
	Figure 6-2. External Transfer Switch Wiring	25
	Figure 6-3A. External Transfer Switch System Wiring	26

Table of Contents (Continued)

	Figure 6-3B. Optional Internal Transfer Switch System Wiring	27
	Table 1 TR12 Single-Speed Wiring Diagram. Standard Configuration Hoist, Trolley and Bridge	28
	Table 2(A) TR12 2-Speed Wiring Diagram. Standard Configuration Hoist, Trolley and Bridge	30
	Table 2(B) TR12 2-Speed Wiring Diagram. 2-Speed with Directional Controls: All Motions	32
	Table 2(C) TR12 2-Speed Wiring Diagram. 2-Speed, 2-Windings: All Motions	34
	Table 2(D) TR12 2-Speed Wiring Diagram. ACCO Controls: All Motions	36
	Table 2(E) TR12 2-Speed Wiring Diagram. P&H: 2-Speed, 2-Windings for Hoist and Trolley; Standard Bridge	38
	Table 2(F) TR12 2-Speed Wiring Diagram. P&H: 2-Speed, 2-Windings for Hoist; Standard Trolley and Bridge	40
	Table 2(G) TR12 2-Speed Wiring Diagram. Demag: 2-Speed, 2-Windings for Hoist; Standard Trolley and Bridge	42
	Table 2(H) TR12 2-Speed Wiring Diagram. Standard 2-Speed 4 Motor System	44
	Table 2(I) TR12 2-Speed Wiring Diagram. Standard 2-Speed 3, 4 & 5 Motor System using Select	46
7-	Programming	48
	1. Access Code Programming	48
	Figure 7-1. Access Code Settings	48
	2. Receiver Frequency Programming	50
	Figure 7-2. RF Receiver Board	50
	3. Multibox	52
	Figure 7-3 SW4 Receiver Multibox Switches	53
	4. Custom Receiver Programming	54
	5. Receiver Programming	54
	6. Membrane Transmitter Programming	55
	Figure 7-4. Repositioning of Membrane Transmitter Motion Switch Functions	57
	Figure 7-5. Membrane Transmitter Single-Speed Configurations	58
	7. Pendant Transmitter Programming	59
	Figure 7-6. Repositioning of Pendant Transmitter Motion Switch Functions	61
	8. telePilot Programming	62
	Figure 7-7. Single-Speed 10K telePilot Modes	69
	Figure 7-8. Single-Speed 10K telePilot Lockout Modes	72
	Figure 7-9. 2-Speed 9001 and 9101 Series telePilot Functional Mapping	73
8-	Servicing	76
	1. Receiver Servicing	76
	Figure 8-1. Receiver Board Layout	76
	Table 8-1. Receiver Board Diagnostic LED Functions	76
	2. Receiver Testing	78
	Figure 8-2. Receiver Scope Wave Forms	79
	3. Membrane Transmitter Servicing	80
	Figure 8-3. Membrane Transmitter M/C Module E10635	80
	4. Pendant Transmitter Servicing	81
	Figure 8-4. Pendant Transmitter M/C Module E10636	81
	5. telePilot Servicing	82
9-	Spare Parts	83
	Figure 9-1 telePilot Exploded View	86
Appendix A-	Transmitter Switch Programming	87

Section 1 - Service Information

1-1. Service Information.

For questions regarding service or technical information or ordering replacement parts, ask for Telemotive Customer Care. Telemotive's normal business hours are Monday through Friday 8:00 AM to 5:00 PM Central Standard Time. After hours emergency technical service is available.

For new product orders or quotations, ask for Telemotive Sales.

Magnetek Material Handling Group
N49 W13650 Campbell Drive
Menomonee Falls, WI 53051

Telephone: 800-288-8178

Website: www.telemotive.com
e-mail: info@telemotive.com

Fax Numbers

Main: 800-298-3503
Sales: 262-783-3510
Service: 262-783-3508



Telemotive Industrial Control trademarks: Telemotive, TMS, *telePilot*, Laser Guard, Teledrive, Teltec, TeleMotion are either trademarks or registered trademarks of Telemotive Industrial Controls.

Third-party trademarks: All other trademarks, trade names or company names referenced herein are used for identification only and are the property of their respective owners

Section 2 – Radio Controlled Safety

2-1. Warnings, Cautions And Notes.

Through out this document **WARNING**, **CAUTION** and **NOTE** statements have been deliberately placed to highlight items critical to the protection of personnel and equipment.

WARNING – A warning highlights an essential operating or maintenance procedure, practice, etc. which if not strictly observed, could result in injury or death of personnel, or long term physical hazards. Warnings are highlighted as shown below:



CAUTION – A caution highlights an essential operating or maintenance procedure, practice, etc. which if not strictly observed, could result in damage to, or destruction of equipment, or loss of functional effectiveness. Cautions are highlighted as shown below:



NOTE – A note highlights an essential operating or maintenance procedure, condition or statement. Notes are shown as below:

NOTE

WARNINGS, CAUTIONS AND NOTES SHOULD NEVER BE DISREGARDED.

The safety rules in this section are not intended to replace any rules or regulations of any applicable local, state, or federal governing organizations. The following information is intended to be used in conjunction with other rules or regulations already in existence. It is important to read all of the safety information contained in this section before installing or operating the Radio Control System.

2-2. Critical Installation Considerations.

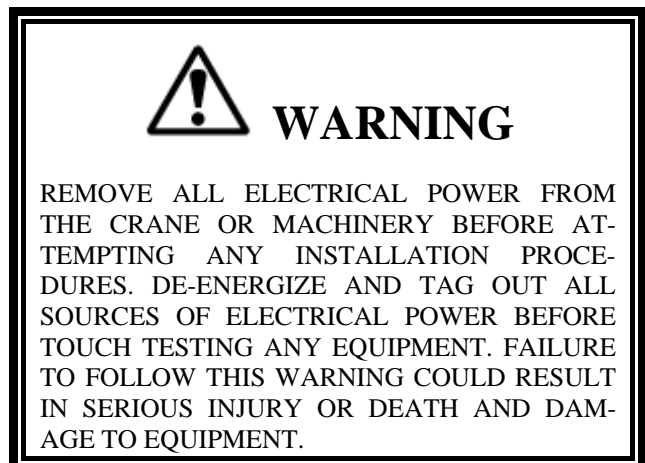
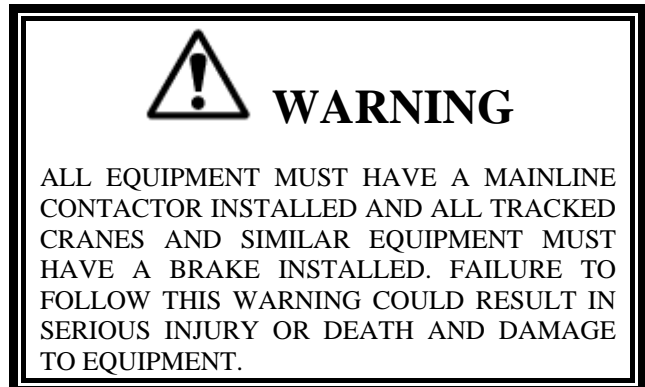

Section 2 – Radio Controlled Safety (Continued)



WARNING

THE DIRECT OUTPUTS OF THIS PRODUCT ARE NOT DESIGNED TO INTERFACE DIRECTLY TO TWO STATE SAFETY CRITICAL MAINTAINED FUNCTIONS, I.E., MAGNETS, VACUUM LIFTS, PUMPS, EMERGENCY EQUIPMENT, ETC. A MECHANICALLY LOCKING INTERMEDIATE RELAY SYSTEM WITH SEPARATE POWER CONSIDERATIONS MUST BE PROVIDED. FAILURE TO FOLLOW THIS WARNING COULD RESULT IN SERIOUS INJURY OR DEATH AND DAMAGE TO EQUIPMENT.

2-3. General.

Radio controlled overhead cranes and other material handling equipment operate in several directions. They are large, bulky pieces of equipment that handle heavy loads efficiently at high speeds. Quite frequently, the equipment is operated in areas where people are working on the floor below. The crane operator must exercise extreme caution at all times. Workers must constantly be alert to avoid accidents. The following rules have been included to indicate how your careful and thoughtful actions may prevent injuries, damage to equipment, or even save a life. If radio controlled material-handling equipment is operated from the cab, special care must be taken to secure the transmitter. Refer to section titled Section 2-10. Boarding The Crane for specific safety rules.

2-4. Persons Authorized To Operate Radio Controlled Cranes.

Only properly trained persons designated by management should be permitted to operate radio-controlled cranes.

Radio controlled cranes should not be operated by any person who cannot read or understand signs, notices and operating instructions that pertain to the crane.

Radio controlled cranes should not be operated by any person with insufficient eyesight or hearing or by any person who may be suffering from a disorder or illness or is taking any medication that may cause loss of crane control.

2-5. Training Checklist For Crane Operators.

Anyone being trained to operate a radio-controlled crane should possess as a minimum the following knowledge and skills before operating the crane:

The operator should have knowledge of hazards peculiar to crane operation.

The operator should have knowledge of the safety rules for radio-controlled cranes.

The operator should have the ability to judge distance or moving objects.

The operator should have knowledge of the radio transmitter.

The operator should know the limit switch test procedure.

The operator should know, where authorized, instructions for plugging motions.

The operator should have knowledge of the use of crane warning lights and alarms.

The operator should have knowledge of observing crane signal lights.

The operator should be trained to avoid striking any obstructions.

The operator should have knowledge of the proper clearance of lifts or hooks before moving bridge or trolley.

The operator should have knowledge of the proper storage space for radio control box when not in use.

The operator should be trained in transferring radio control box to another person.

The operator should be trained how and when to report unsafe or unusual operating conditions.

The operator should be trained how to exhibit caution in approaching bridge or trolley bumpers.

The operator should know equipment capacity.

The operator should be trained in making lifts below floor level.

The operator should be trained in making side pulls.

The operator should know how to keep himself and other people clear of lifts and to avoid "pinch" points.

Section 2 – Radio Controlled Safety (Continued)

The operator should know cable and hook inspection procedures.

The operator should know procedures for testing hoist, trolley, and bridge brakes.

2-6. Operating Area.

Aisles between equipment, stock, etc., should be free of obstructions so the crane operator can move freely. These aisles should be a minimum of three feet (one meter) wide, or meet local regulations.

Crane operators should always position themselves for the best view of the crane they are controlling. The crane should never be operated blindly. The operator should stay as close to the crane load as possible. Operators should never position themselves in a "pinch" point.

2-7. Transmitter Unit.

Transmitter switches should never be mechanically blocked ON or OFF for any crane motion. When not in use turn the transmitter OFF. A secure storage space should be provided for the transmitter unit and the transmitter unit should always be placed there when not in use. This precaution will prevent unauthorized people from operating the crane.

Spare transmitters should be stored in a secure storage space and only removed from the storage space after the current transmitter in use has been turned OFF, taken out of the service area and secured.

2-8. Operating The Crane.

2-8.1. Pre-operation Test.

At the start of each work shift, or when a new operator takes control of the crane, operators shall do as a minimum the following steps before making lifts with any crane or hoist:

Test the upper-limit switch. Slowly raise the unloaded hook block until the limit switch trips. When checking limit switches the hoist should be centered over an area free of personnel and equipment.

Visually inspect the hook, load lines, trolley, and bridge as much as possible from the operator's station; in most instances, this will be the floor of the building.

The bridge and trolley brakes should be tested. On transmitter units equipped with two or more speeds, use the "lowest" speed when testing braking devices.

When lifting maximum loads, the crane operator should test the hoist brakes by raising the load a few inches from the floor. If the brakes do not hold, the load should immediately be lowered to the floor.

If provided, test the lower-limit switch.

Test all warning devices.

Test all direction and speed controls for both bridge and trolley travel.

Test all bridge and trolley limit switches, where provided, if operation will bring the equipment in close proximity to the limit switches.

Test the transmitter emergency stop.

Test the hoist brake to verify there is no drift without a load.

If any crane or hoist that fails any of the above tests notify the supervisor and lock out and tag for repair.

2-8.2. General Rules For Operation.

Consult the crane manufacturer, local and governmental regulations for complete rules of operation. In general the following rules apply to remotely controlled cranes:

The limit switches should never be used as a regular stopping device. They are intended to be protective devices.

Do not make lifts in excess of the equipment rated capacity.

The bridge and trolley should be centered directly over the load when the load is raised to prevent swinging when making lifts.

A crane designed for this purpose and only with supervisor permission should make side pulls. When a lift is being made, the crane operator should not be positioned in the line of travel. The crane or hoist should be operated from a position either to the side or opposite from the direction of travel.

When raising or lowering a load, proceed slowly and make certain the load is under control. Tag lines should be used for handling unusual lengths or bulky loads. Remove slack from chains or slings gradually.

Section 2 – Radio Controlled Safety (Continued)

Make certain all personnel are clear before making a lift.

The crane operator should keep all body parts away from the lift and should never be positioned under the lift.

Do not make a lift or move a load if anyone is in a location where they could be struck by the crane or the load.

If the crane operator is being helped, the crane should not be moved until the helper signals they are clear of the crane and its load.

When a load is hanging from the crane hook and the crane is being moved, the crane operator should sound all warning devices frequently.

Loads should not be carried over workers heads. If a worker is in the path of crane travel, the crane operator should stop the crane and clear the area before proceeding.

Runway stops or other cranes should never be bumped into.

When moving the crane, the crane operator should be sure that the hook block and attachments or cables would not catch on nearby equipment. Slings, chains, or cables should never be dragged along the floor.

Unless required for operator safety, gloves should not be worn when operating the transmitter unit.

All loose materials or parts should be removed from the load before starting the lift.

The crane operator should always hoist lifts high enough to clear all equipment and workers.

The crane operator should never permit anyone to ride on the load or hook except when authorized by the supervisor.

When another crane on the same runway is stationary with a load hanging, the crane operator should maintain a safe distance between the stationary crane and the one under their control.

Never leave suspended loads unattended. In an emergency, if the crane is inoperative and a load suspended, notify the supervisor immediately, barricade and post signs on the floor beneath crane and load.

If power to the crane is removed, the crane operator should turn the transmitter unit OFF and keep it OFF until power is restored.

If the crane fails to respond properly, the crane operator should stop operation, turn the transmitter unit OFF and immediately report the condition to their supervisor.

Outdoor cranes, which are subject to movement by wind, should be securely anchored when left unattended. If the crane is equipped with bridge brakes, the parking brake should be set immediately.

2-9. Boarding The Crane.

The crane should not be boarded without permission of the supervisor.

The crane operator should turn off the transmitter and take it with them when boarding the crane.

If more than one person is boarding the crane, one person should be made responsible for ensuring all personnel are off the crane before the system is returned to operation.

2-10. Crane Maintenance And Repair.

Qualified personnel must maintain a regularly, i.e., such as monthly, scheduled crane inspection. During this crane inspection the functionality and safety of the crane remote control must also be tested. The inspection shall include, but be not limited to items listed in Section 2-13. Condition Of The Radio Controlled Crane. Consult crane manufacturer, local and governmental regulations for recommended inspection intervals and proper inspection procedures. Problems noted during this inspection must be repaired before using the crane or the remote control.

Minor repairs include routine maintenance and repairs such as greasing, cleaning and control troubleshooting. All other repairs should be considered major. If the repair crew consists of more than one person, one person should be designated as the repair crew leader with the following responsibilities. If the repair crew consists of only one person, that person has the following responsibilities:

For minor repairs warning signs should be placed on the floor beneath the crane or suspended from the crane. For major repairs, the floor area below the crane should be roped off.

Section 2 – Radio Controlled Safety (Continued)

When major repairs are to take place, all persons operating other cranes on the same or adjacent runways, if any, must be notified prior to starting repairs. Notification should include the nature of the repair, safeguards provided, and movement limitations while repairs are in progress.

When practical, radio controlled cranes which cannot be moved during repairs must be protected against being bumped by other cranes on the runway. Bumpers should be installed on the exposed side or sides of the crane under repair. They should be placed as far away as possible. The location of these bumpers should be indicated by red lights placed so that they are clearly visible to other crane operators traveling on the same runway. When it is not possible to use bumpers, red lights must be placed so they are clearly visible to other crane operators traveling on the same runway to indicate the restricted travel zone. All crane operators on the same runway must be informed of the repair effort and thoroughly instructed to what their operations are limited to and informed they will be notified when repairs are completed.

If any hazard involving the repairmen exists when there is a runway adjacent to the crane under repair, the adjacent runway should be blocked off as described above. When it is necessary to continue crane operation on the adjacent runways warning lights must be installed and be visible to operators of cranes on those runways. All cranes should come to a complete stop prior to entering the restricted area and should proceed through this area only after receiving permission from a signal person designated for this purpose. Access of persons to and from the crane being repaired should be under control of the repair crew leader.

When boarding the crane, the transmitter should be turned OFF and the transmitter should remain with the repair crew leader. The leader should board the crane first, open and lock out the main switch, and then signal the other members of the crew it is safe to board the crane.

If work on the crane is to be done in areas not protected by standard handrails, the repair crew should wear approved safety belts.

All tools and equipment should be moved onto the crane by the use of hand lines. The tools and equipment should be adequately secured to the hand lines.

If it is necessary to have the crane control circuits energized, all power circuits for crane movement must be opened prior to energizing the control circuits.

All personnel and tools should be moved to a safe spot before moving the crane during repairs.

Headroom is at a minimum in some crane cabs and on some crane walkways. Caution should be exercised when boarding or working on cranes. Hard hats should be worn whenever possible.

When repairs are finished, all personnel, tools and repair equipment should be removed before energizing the crane circuits.

2-11. Using The Crane As A Work Platform.

When the crane is to be used as a stationary work platform, follow all rules provided in Section 2-11. Crane Maintenance and Repair. When it is necessary for the crane to be moved from time to time, the crane operator should board the crane with the transmitter unit. The crane operator should ensure all personnel working on the crane are in a secure position before moving the crane to the next workstation. It should also be the crane operators responsibility to ensure the main switch is open and locked down before work is resumed.

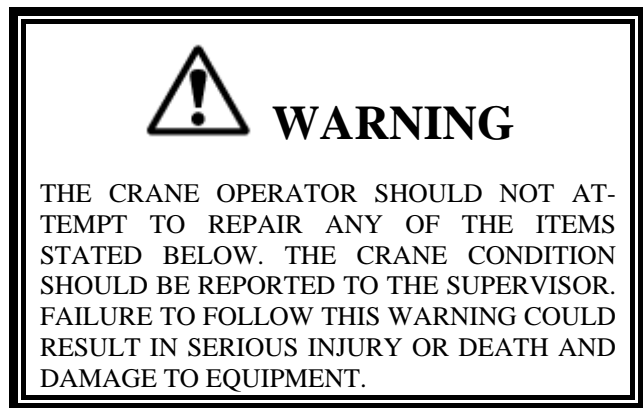

2-12. Condition Of The Radio Controlled Crane.

If the crane fails to respond properly, the crane operator(s) should notify their supervisor. When serious conditions are noticed (conditions that make the crane unsafe to operate), the crane should be shut down immediately and the supervisor notified. The following is a list of some of the items that should be included in the report. (See the crane manufacturer for specifics and possible additional items):

Section 2 – Radio Controlled Safety (Continued)

Condition of hoisting cable and hook block (broken strands, clipped sheave wheels, etc.).

Condition of brakes (hoist, trolley, and bridge). (No bluing, rivets on shoes showing, glazing, etc.).

Condition of trolley and rail stops.

Condition of bridge structure.

Condition of festoon system.

Broken welds in any part of the crane structure.

Proper fluid levels and lubrication.

Condition of bridge and trolley stops.

Carbon dust or signs burning on the covers of motors.

Indication of fluid, oil or grease leaks.

Condition of rail sweeps.

Walkways required handrails and ladders are in place, sturdy and not loose.

Protective guards are in place for all moving parts.

Alignment of bridge (screeching or squealing wheels indicate bridge is out of line).

Broken, cracked, or chipped rails on trolley or runway.

Condition of limit switches.

Condition of electrical and mechanical control (electrical or mechanical defects which cause faulty operation such as un-commanded stopping or starting of any crane motions, warning devices, lights, or auxiliary functions).

Condition of gears (grinding or squealing may indicate foreign materials in gear teeth or a lack of lubrication).

All controls especially E-STOPS are in place and in working order.

Frequent relay tripping of power circuits.

Mechanical parts loosened by vibration (loose rivets, covers, bolts, etc.).

Uneven riding (worn or damaged wheels).

Condition of collector shoes or bars.

Condition of warning or signal lights and horns. (Burned out or broken).

2-13. Batteries



WARNING

KNOW AND FOLLOW PROPER BATTERY HANDLING, CHARGING AND DISPOSAL PROCEDURES. IMPROPER BATTERY PROCEDURES CAN CAUSE BATTERIES TO EXPLODE OR DO OTHER SERIOUS DAMAGE. FAILURE TO FOLLOW THIS WARNING COULD RESULT IN SERIOUS INJURY OR DEATH AND DAMAGE TO EQUIPMENT.

2-13.1. Battery Handling.

Use only batteries approved by Telemotive for the specific product.

Do not dispose of a battery pack in fire; it may explode.

Do not attempt to open the battery pack.

Do not short circuit battery.

For intrinsically safe environments only use specified Telemotive intrinsically safe batteries.

Keep the battery pack environment cool during charging operation and storage, (i.e., not in direct sunlight or close to a heating source).

2-13.2. Battery Charging.

For those transmitters equipped with battery chargers, please familiarize all users with the instructions of the charger before attempting to use.

Use only Telemotive approved chargers for the appropriate battery pack.

Do not attempt to charge non-rechargeable battery packs.

Avoid charging the battery pack for more than 24 hours.

Do not charge batteries in a hazardous environment.

Do not short charger.

Section 2 – Radio Controlled Safety (Continued)

Do not attempt to charge a damaged battery.

Do not attempt to use a battery that is leaking, swollen or corroded.

Charger units are not intended for outdoor use. Use only indoors.

2-13.3. Battery Disposal.

Before disposing of batteries consult local and governmental regulatory requirements for proper disposal procedures.

Section 3 – General System Information

3-1. General System Information.

The Telemotive Radio Control System (system) provides remote control of overhead cranes using radio signals. The system consists of a hand held portable battery operated transmitter unit and a fixed station receiver unit.

A unique 16-bit code (Access Code) for each system is preset in every transmitter and receiver. The receiver considers any received signal, which does not match the receiver access code setting, invalid. The Access Code is made up of 16-bits (65,000 combinations) and no two similar codes are assigned to any two Telemotive systems.

Up to four systems may be used with the same frequency in a 600-foot area (220 meters). Each transmitter operating on the same frequency may be operated in close proximity, not less than six feet (1.9 meters), to each other.

3-2. TMS Low Power Signaling.

TMS (Time Multiplexed Signaling) is a Telemotive proprietary high-speed packet data system. The system software is structured to minimize "on the air" transmission time of any transmitter. This allows for multiple transmitters to share a common frequency. The TMS system is designed so that a transmitter will send a signal for a predetermined ON time, and then will turn OFF. The length of transmitter ON time is referred to as data burst or packet. The packet length is a function of the quantity of data to be sent, and the data rate (baud). Once the packet is sent, the transmitter will turn OFF. This allows for other transmitters to time-share the same frequency when a transmitter has turned OFF. The TMS system software determines the OFF period and repetition rate of the ON period. Since each system has its own access code, up to 4 transmitters can share and have equal access to the same frequency. TMS also allows for reduced battery consumption and extended battery life.

These systems have low power pulsed signaling, FCC certified under Part 15 Telecommunications Code of Regulations, no license is required. The transmitter unit is frequency modulated, low power and is certified under the appropriate regulations. A license is not required for the transmitter or operator. Modifications to the RF section of this system are not permitted and could void FCC certification.

3-3. Channel Designations:

AK01 - 439.8 MHz	AK06 - 438.8 MHz
AK02 - 439.6 MHz	AK07 - 438.6 MHz
AK03 - 439.4 MHz	AK08 - 438.4 MHz
AK04 - 439.2 MHz	AK09 - 438.2 MHz
AK05 - 439.0 MHz	AK10 - 438.0 MHz

AK11 - 437.8 MHz	AK16 - 436.8 MHz
AK12 - 437.6 MHz	AK17 - 436.6 MHz
AK13 - 437.4 MHz	AK18 - 436.4 MHz
AK14 - 437.2 MHz	AK19 - 436.2 MHz
AK15 - 437.0 MHz	AK20 - 436.0 MHz

AKA00 - 433.125 MHz	AKA05 - 434.125 MHz
AKA01 - 433.325 MHz	AKA06 - 434.325 MHz
AKA02 - 433.525 MHz	AKA07 - 434.525 MHz
AKA03 - 433.725 MHz	AKA08 - 434.725 MHz
AKA04 - 433.925 MHz	

3-4. System Specifications.

Receiver housing: NEMA 4X, IP67

Transmitter housing: IP65.

Operating Temperature: -22° F to +158° F (-30° C to +70° C) ambient.

Humidity: up to 95 % (non-condensing).

Typical Operating Range: 200 feet (70 meters).

Rating of output relays (including Master Relay): 16 Amp 277 VAC/24 VDC, 1 HP 240 VAC.

3-5. Transmitter Unit.

The transmitter is battery operated has an ON and OFF switch, E-STOP, motor controls and auxiliary controls used for such item warning indicators.

LED's mounted on the front panel provide indication of battery voltage, ON/OFF, Modes and data transmission status.

A power down feature allows the transmitter and the receiver unit to turn OFF if no keys are pressed for predetermined number of minutes. The transmitter unit must again be turned ON. The unit uses pulsed operation for extremely long battery life. A configuration of the system is available without automatic timeout.

Housings are designed of high impact, chemical resistant, materials. The antenna for the unit is

Section 3 – General System Information (Continued)

internal. A strap or belt is provided for carrying the transmitter.

3-6. Receiver Unit.

The receiver unit consists of a synthesized RF module, built in antenna, integral power supply, microprocessor controlled output motor control and auxiliary function relays and mainline contactor relay. The receiver unit contains circuitry, which matches the frequency and access code of the transmitter.

Section 4 – Installation Procedure

4-1. Pre-Installation Considerations.

To ensure reliable and safe operation of the system, the following items must be considered before installing the receiver unit.



WARNING

THE RECEIVER UNIT OR RELAYS ARE NOT RATED AS EXPLOSION PROOF. THE RECEIVER UNIT MUST NOT BE INSTALLED IN EXPLOSIVE ENVIRONMENTS UNLESS APPROPRIATE SECONDARY ENCLOSURE MEASURES ARE TAKEN. FAILURE TO FOLLOW THIS WARNING COULD RESULT IN SERIOUS INJURY OR DEATH AND DAMAGE TO EQUIPMENT.

4-2. Receiver Unit Mounting Location Considerations.

Ensure the mounting location is as far as possible from exposed trolley wires and sources of electromagnetic or radiated noise

The receiver cabinet is approximately 8" (20 cm) wide by 12" (30 cm) high. A depth of at least 6" (15 cm) must be provided to allow the cabinet door to open.

The mounting surface must be smooth and continuous. Mounting the cabinet on uneven surfaces could cause warpage or stress internal components.

The receiver unit may be mounted in any position. Greatest radio control range is obtained when the receiver unit is mounted with the antenna at the top.

If possible, avoid installing receiver unit to a surface where high vibration or shock is present. If this cannot be avoided, use appropriate shock mounts.

4-3. Antenna Mounting Considerations.

The antenna is internal and requires no additional mounting. The antenna is at the top of the receiver cabinet and should not be placed near large metal objects that could be close to or cover the top of the box. Allow at least six inches above the top of the box for clearance.

4-4. Line Input Considerations.



WARNING

THE UNIT MUST BE WIRED TO THE CORRECT VOLTAGE, AND BE CONNECTED TO THE CORRECT TERMINAL AS REQUIRED BY THE ACTUAL LINE VOLTAGE. FAILURE FOLLOW THIS WARNING COULD RESULT IN SERIOUS INJURY OR DEATH AND DAMAGE TO EQUIPMENT.

The receiver unit has direct connect provisions for operation from 120 (nominal), 50-60 Hz power.

For applications where line voltage deviation exceeds 20% of nominal values if line voltage is not between

95-130 VAC or 190-260 VAC or if 440 VAC power is used, a step up or step down transformer must be used.

NOTE

THE RECEIVER UNIT SHOULD NOT BE CONNECTED TO LINES CONTAINING EXCESSIVE POWER UP TRANSIENTS OR CONTINUOUS COMMUTATOR NOISE. A LINE CONDITIONER MAY BE NECESSARY IN SOME INSTALLATIONS.

4-5. Wiring Considerations.

1. Read this manual before installation.
2. Please observe appropriate local and National Electrical Codes when wiring electrical devices.
3. Do not connect or disconnect wiring, or perform circuit checks while the power is turned on.
4. The motor wiring should be in a separate metal conduit from the power wiring, which should also be in metal conduit.
5. Low voltage wires shall be wired with proper low voltage class wiring procedures.

Section 4 – Installation Procedure (Continued)

6. Control wiring as well as antenna wiring shall be in separate conduit and shall be kept as short as possible.

7. All terminals shall be tightened to specified terminal torque 4.4 IN-LBS (.5 N·m). Unless otherwise specified.

8. Remove excess metal screws, metal filings and wire clippings from inside of unit.

9. Inspect to make sure no exposed wire has contact with any other wiring or terminals.

10. Suppressors are strongly recommended on all contactors.

4-6. Receiver/Equipment Interface Considerations.

All output relay contacts are rated at 16 amps 250 VAC, however the system rating for the contacts is 5 Amps. Connection to equipment or contactors with higher voltage or current requirements will require intermediate relays.

All relay outputs are normally open, momentary contact. Since a relay closure is only active while the transmitter unit key is pressed and held, devices such as lights or lifting magnet must use a mechanical auxiliary latching relay.

NOTE

FOR INFORMATION ON INTERFACING WITH SYSTEMS WITH HIGH IMPEDANCE INPUTS SEE SECTION 6-8. CONNECTING OUTPUTS TO DRIVES OR CONTACT TELEMOTEIVE.

4-7. Receiver Unit Cabinet Mounting.

Mounting brackets are provided. See next page Figure 4-2. Receiver Mounting Details. Allow room in mounting the receiver for the door to swing open

Mount receiver unit cabinet securely to mounting surface. Actual cabinet mounting dimensions are shown on next page Figure 4-2. Receiver Mounting Details.

4-8. Receiver Installation.

1. Normally it should not be necessary to set the access codes, they are preset. Program the unit for any special crane configurations

or other parameters, if desired, see Section 7. Programming for details.

2. Position the receiver. Locate as far as possible from exposed trolley wire and sources of electromagnetic or radiated noise. Cabinet mounting dimensions and mounting template is on next page see Figure 4-2A and B. Receiver Mounting Details. Antenna at top of unit should be kept as clear as possible of any metal object.

3. Mount the receiver. Mounting brackets are provided to accommodate mounting on to a metal strut mounting system. The four deep mounting holes in corners of the receiver mounting brackets use quantity four #10-24 combo drive round head screws 1 ½ “ in length, four #10 lock washers and four #10-24 hex nuts to mount to the mounting brackets. Lock washers should be used in front of hex nuts. Four flat washers are .400 I.D. x 1 ½” O.D. are supplied with use for mounting the mounting brackets to a metal strut.

4. Wire the unit using the appropriate electrical drawings for the specific transmitter and crane orientation selected, see Section 6. Wiring. For the Membrane or Pendant transmitter determine crane orientation; if the direction pair labeled on the transmitter better describes the equipment movement. Use this pair to wire the motor directionals respectively. If you need to remove the main board (4 screws) the antenna unplugs from the RF Receiver, be sure to dress the antenna cable under the hook on the RF Receiver when reinstalling the antenna cable.

5. Wire the power to J1 input power connector. The connections are Ground (GND), Neutral (N) and 120 VAC 50-60 Hz (120V). See Figure 4-1. Input Power Connections.

6. Wiring of the system should now be complete.

7. Stand clear of the crane and apply AC power to receiver unit. Turn switch SW2 OFF (MR relay control) and SW1 ON (main power switch). Check to see if four LEDs are lit: (green; DS22, DS23 and DS24) and (red; RF Receiver ON). If none are lit check AC power, power switch SW1 and fuse.

Section 4 – Installation Procedure (Continued)

8. Turn transmitter ON. Check to see if the yellow LED is now lit (DSMR1). At this point the MR relay is disabled, the functions of the transmitter can be checked by noting the turning ON of the appropriate red LEDs next to the control relays (DS7 to DS11). After checking out the functions, turn switch SW2 ON to enable the MR relay, check function and direction by jogging each motion. Installation should now be complete.

9. If there are any problems see Section 8. Servicing.

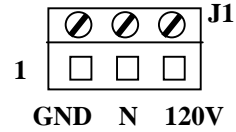
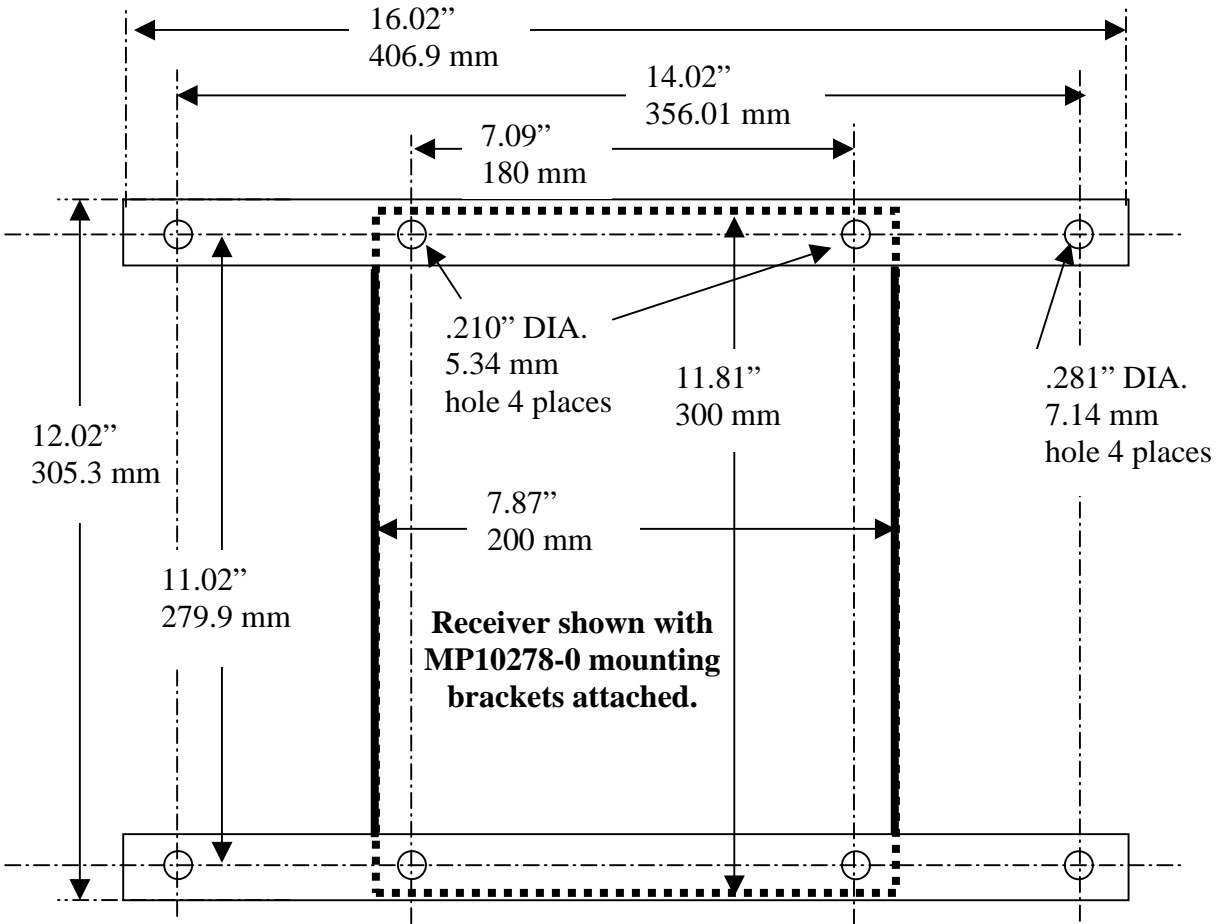

Figure 4-1. Input Power Connections.



Drawing not to scale.

Overall Cabinet Depth	With door closed inches	With door closed mm	With door open inches	With door open mm
Cabinet	5.26	133.60	12.12	307.98
Cabinet and mounting bracket	5.44	138.07	12.30	312.44
Cabinet, mounting bracket & 1 ½" strut	6.94	176.17	13.80	350.54

Figure 4-2A. Receiver Mounting Details with Horizontal Mounting Brackets.

Section 4 – Installation Procedure (Continued)

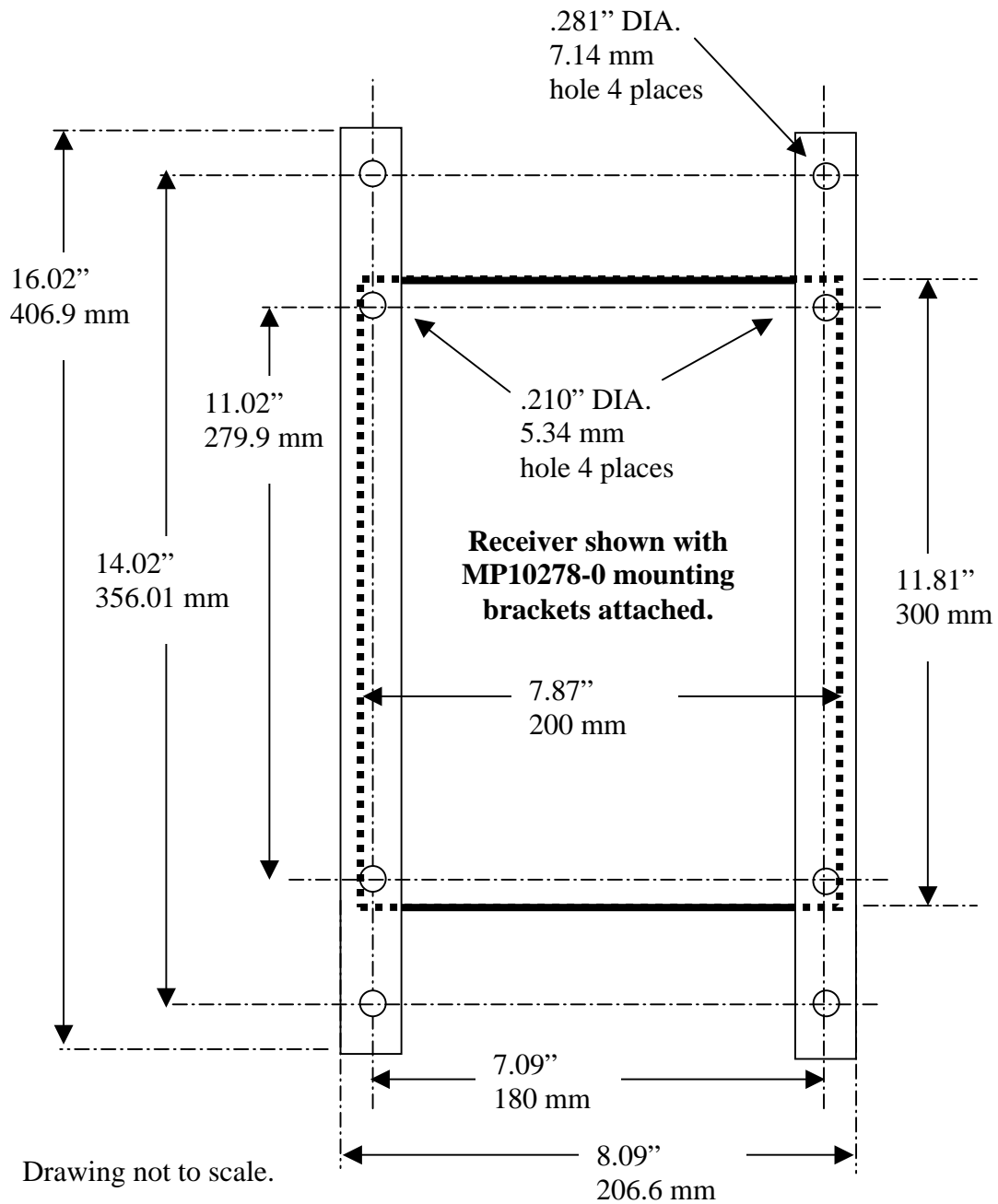

Overall Cabinet Depth	With door closed inches	With door closed mm	With door open inches	With door open mm
Cabinet	5.26	133.60	12.12	307.98
Cabinet and mounting bracket	5.44	138.07	12.30	312.44
Cabinet, mounting bracket & 1 ½" strut	6.94	176.17	13.80	350.54

Figure 4-2B. Receiver Mounting Details with Vertical Mounting Brackets.

Section 5 – Operation

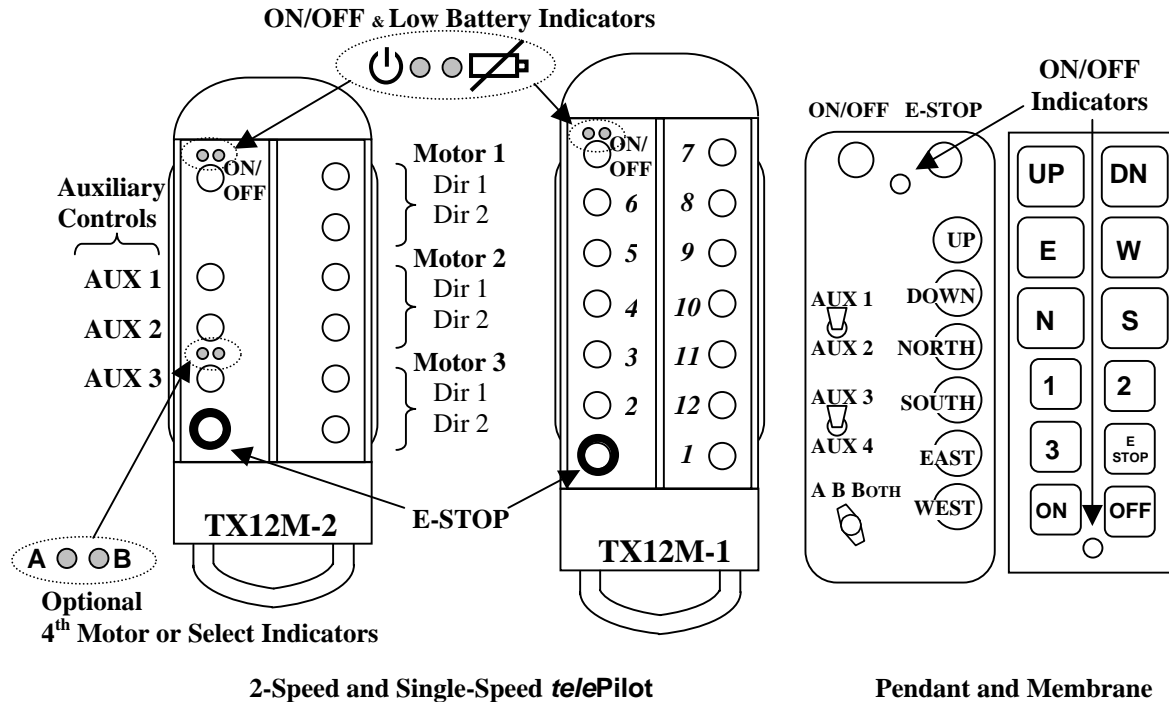

Figure 5-1. telePilot, Pendant and Membrane

5-1. Transmitter Buttons.

ON/OFF On the telePilot and Pendant Transmitter ON and OFF is the same button. Pushing this button toggles between turning the transmitter ON and then sending the ON command to the receiver and sending the OFF command to the receiver and then turning the transmitter OFF.

NOTE

IN THE TELEPILOT THE TRANSMITTER DOES NOT TURN ON TILL THE ON PUSH BUTTON IS RELEASED AFTER BEING DEPRESSED TO TURN ON. THE OFF FUNCTION IS IMMEDIATE UPON DEPRESSING THE ON/OFF PUSH BUTTON.

(Membrane only) ON Turns the transmitter ON and then sends the ON command to the receiver.
OFF Sends the OFF command to the receiver and then turns the transmitter OFF.

E-STOP (EMS) – Stops all equipment movement and disables all functions except Alarm. Reset the system for normal operation by turning the transmitter “OFF” then “ON”. Use for emergencies only. (NOT FOR NORMAL SHUT DOWN).

NOTE

ON THE TELEPILOT TRANSMITTER THE USER CAN CHOOSE AND CUSTOM LABEL THE FUNCTIONS FOR A SPECIFIC MOTOR THE FUNCTIONAL DESIGNATIONS SHOWN BELOW ARE COMMON AND TRADITIONAL DESIGNATIONS.

Common 2-Speed Designations Listed Below:

Motor 1 Dir 1, (Hoist) UP – Selects hoist movement in the UP direction speed one (first switch position) or speed two (second switch position).

Motor 1 Dir 2, (Hoist) DN/DOWN – Selects hoist movement in the DOWN direction speed one (first switch position) or speed two (second switch position).

Motor 2 Dir 1, (E Membrane)/NORTH Pendant– Selects the appropriate direction of the bridge or trolley (depending how unit is wired at installation) speed one (first switch position) or speed two (second switch position).

Motor 2 Dir 2, (W Membrane)/SOUTH Pendant – Selects the appropriate direction of the bridge or trolley (depending how unit is wired at installation) speed one (first switch

Section 5 – Operation (Continued)

position) or speed two (second switch position).

Motor 3 Dir 1, (N Membrane)/EAST Pendant

– Selects the appropriate direction of the bridge or trolley (depending how unit is wired at installation) speed one (first switch position) or speed two (second switch position).

Motor 3 Dir 2, (S Membrane)/WEST Pendant

– Selects the appropriate direction of the bridge or trolley (depending how unit is wired at installation) speed one (first switch position) or speed two (second switch position).

(telePilot Only) Optional 4th Motor Or Select with Indicators A ○ ○ B

The AUX 3 pushbutton can be designated as an auxiliary motor select. As an example for systems that have a main and auxiliary hoist, pushing this switch will toggle the function of the set of motor 1 pushbuttons between the outputs for main and auxiliary hoist.

There are two red LEDs above this pushbutton labeled “A” and “B”. The “A” LED comes ON for the main function and the “B” comes ON for the auxiliary. As the pushbutton is toggled the sequence of outputs and LEDs is as follows. Normally the main output only is active and the “A” LED is lit. Pushing the pushbutton lights only the “B” LED and the auxiliary output only is active. Pushing the pushbutton a second time lights both “A” and “B” LEDs and both main and auxiliary outputs are active in tandem. (This tandem operation can be disabled See Section 7-8. *telePilot* Programming). When turning the transmitter ON the default condition is always “A”.

This pushbutton can be used with the Select function also. When used for the Select function the “A” and “B” LEDs work as described in the above paragraph toggling the Select 1 output and the Select 2 outputs respectively.

1, 2 And 3 (AUX 1, AUX 2, and AUX 3) – Selects the Auxiliary relay(s), which may be used for a warning device as a horn or other function.

5-2. ON/OFF LED Indicator.

When the transmitter is ON the red LED flashes slowly. When the unit transmits, the red LED flashes rapidly. Top left indicator on *telePilot*. 

5-3. Low Battery Indication.

In the *telePilot* transmitter there is a separate low battery indicator located to the right of the ON/OFF indicator. This is a yellow LED that turns ON solid when it is time to replace the batteries.

For Membrane and Pendant transmitters if the ON/OFF LED indicator does not light at all after turning ON the transmitter or while operating crane with the transmitter, replace the batteries, they are weak. See Section 5-6. Battery Replacement for battery replacement.

5-4. Optional 4th Motor Select Indicator. A ○ ○ B

For two speed *telePilots* with four motors programmed, this indicator will toggle between “A”, “B” and both (for units programmed with or without tandem operation). Pressing the push button directly beneath the indicators toggles the state.

5-5. Operation.

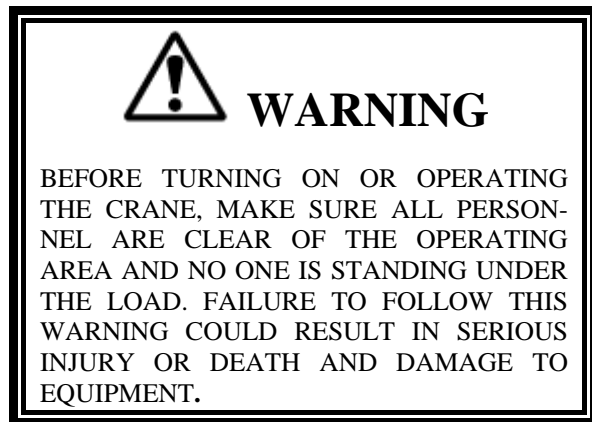

Section 5 – Operation (Continued)



WARNING

WHEN OPERATING THE CRANE FOLLOW LOCAL AND GOVERNMENTAL RULES ON THE USE OF HORNS AND ALARMS. FAILURE TO FOLLOW THIS WARNING COULD RESULT IN SERIOUS INJURY OR DEATH AND DAMAGE TO EQUIPMENT.

Make sure that all personnel are clear of the crane movement and no one is under the crane or load.

Turn unit ON by pressing the ON/OFF (ON) button. The red LED ON/OFF indicator should flash rapidly for a few seconds indicating the ON command is being sent to the receiver. After the receiver is turned ON the red LED should flash slowly indicating the transmitter is now ready to send commands.

Perform whatever safety checks are required. See Section 2. Radio Controlled Safety. Operate any horns or alarms as required by local and governmental regulations.

To operate the crane, press and hold the desired function button to maintain operation. Press the directional buttons harder to second position to engage second speed for those cranes having 2-speed motors.

Always turn system OFF by pressing the ON/OFF (OFF) button on the transmitter when done with crane operation. Do not use the E-STOP button as an ON/OFF button.

In an emergency always hit E-STOP (EMS) immediately. To clear the emergency condition, turn the transmitter OFF and ON again to resume normal operation.

The receiver will time-out after approximately 15 minutes if there is no activity. The transmitter is programmed to time-out if not used for 15 minutes also for membrane and pendant. For *telePilot* the transmitter time out time is selectable.



WARNING

IN AN EMERGENCY HIT “E-STOP” TO STOP ALL CRANE MOVEMENT. WHEN EMERGENCY HAS CLEARED TURN THE TRANSMITTER OFF THEN ON AGAIN TO RESUME NORMAL OPERATION. FAILURE TO FOLLOW THIS WARNING COULD RESULT IN SERIOUS INJURY OR DEATH AND DAMAGE TO EQUIPMENT.

5-6. Additional *telePilot* Transmitter Operational Features. (See Section 7-8. *telePilot* Programming for information on how to program these features).

***telePilot* E-STOP Function.**

The E-STOP command will be repeatedly sent as long as the E-STOP pushbutton is depressed. The E-STOP is always live on the *telePilot* transmitter. Upon pushing the E-STOP pushbutton the transmitter will send an E-STOP command for the last selected Bank even if the unit is turned OFF. (Obviously, if the battery is dead this will not work).

***telePilot* Low Battery Shutoff Function.**

If the battery gets too low the unit will shut off and send an OFF command to the receiver as it turns OFF.

***telePilot* Self-Test Function.**

When the unit turns on if any function key is depressed the unit will fault, not send a turn on command and not become operational. The red LED will stay ON till the unit is turned OFF. The unit will frequently scan the 2nd position of the motion switches while the transmitter is ON and if one of these is closed without the first position closed, the unit will fault as above.

Section 5 – Operation (Continued)

telePilot Red LED ON/OFF Indicator.

The red LED, at the upper most left hand side of the transmitter, operates as follows:

- Be OFF when the transmitter is OFF.
- Flash slowly when the transmitter is ON, but not transmitting. If the transmitter has Bank select enabled there will be a number of quick flashes followed by a pause. The number of quick flashes indicates the Bank the transmitter is in.
- Flash rapidly when the transmitter is transmitting, including during E-STOP when the transmitter is OFF.
- Remain ON continuously for: waiting password, un-programmed Bank selected or a logic or pushbutton fault.

telePilot Battery Yellow Indicator Light.



The yellow LED to the right of the ON/OFF indicator operates as follows:

- Be OFF when the transmitter is OFF.
- Be OFF when the transmitter is ON and the battery is good.
- Remain ON continuously for a low battery needing replacement.

telePilot Bank Select (Normally Password Protected).

This feature is like having four completely different transmitters in one unit. Up to four banks (operational configurations) are possible. A Bank is a specific configuration of user-defined parameters including:

System type

Frequency

Access codes

Also: Key arrangement



Relay configuration

Time-out-timer time

Mode selection

Alarm settings

To select a specific bank, The ON/OFF push button is pressed and held down while one of the four upper most motion push buttons (buttons 1 through 4 see Figure 5-2. Bank and Password Input Buttons) is pressed. Press push button 1 for Bank 1, push button 2 for Bank 2, push button 3 for Bank 3 or push button 4 for Bank 4. While

the Bank button is held down release the ON pushbutton and then the Bank button. (The sequence is important). The transmitter red LED ON/OFF  indicator then stays ON (for five seconds) till the password is entered. Once the password is entered (see below) the transmitter red LED ON/OFF  indicator flashes indicating the current Bank the operator is in while the transmitter is ON and not transmitting. One flash then a pause repeatedly indicates Bank 1, two quick flashes indicates Bank 2, three quick flashes and a pause indicates Bank 3 and so on. The transmitter will remember what Bank it is in even if turned OFF and ON again.

It is not necessary to program all four Banks, if an un-programmed or turned “off” Bank is selected the ON/OFF  indicator will remain ON continuously, the transmitter will send no commands and will turn itself off shortly.

telePilot Bank Password Protection Function.

This enables the owner to create a four-stroke password word to enable changing Banks. With Password enabled the operator selects a four-button sequence to enable a Bank after different Bank has been selected (see above). When the transmitter is turned ON, after Bank Selection is made and the ON/OFF  indicator will remain lit until the correct password sequence is entered within five seconds. An incorrect password sequence or failure to enter the sequence in time shuts the unit OFF. The user is allowed to restart and try again an unlimited amount of times. The Bank Password is the same for all Banks.



WARNING

THIS PASSWORD FUNCTION IS NOT TO BE USED AS A SECURITY DEVICE. THE PURPOSE OF THIS FUNCTION IS TO PREVENT ACCIDENTAL BANK SWITCHING. THE BEST FORM OF SECURITY IS ALWAYS TO LOCKUP THE TRANSMITTER WHEN NOT IN SERVICE. FAILURE TO FOLLOW THIS WARNING COULD RESULT IN SERIOUS INJURY OR DEATH AND DAMAGE TO EQUIPMENT.

Section 5 – Operation (Continued)

When initially programming the unit the default password is 6, 5, 4, 3. This password can be easily changed by the PDA during initial programming.

A password is a sequence of four pushbutton entries. These entries are any combination of inputs from the upper most six buttons on the right hand side of the *telePilot* transmitter. On 2-Speed transmitters the second speed is ignored.

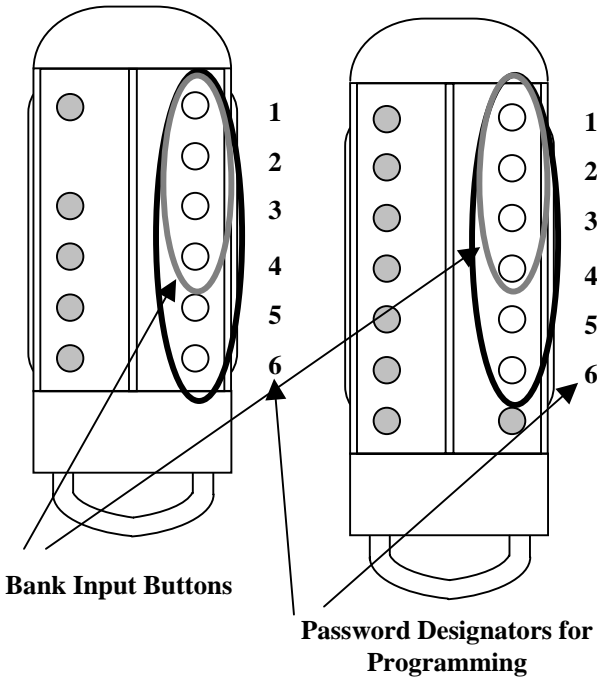

Figure 5-2. Bank and Password Input Buttons.

Acceptable sequences could duplicate buttons numbers such as 2, 2, 6, 6 or 1, 1, 1, 4.

NOTE

ALWAYS REMEMBER TO STORE THE PASSWORD IN A SECURE LOCATION FOR ACCESS IF THE PASSWORD IS LOST OR FORGOTTEN. ONCE THE TRANSMITTER IS PROGRAMMED THERE IS NO WAY TO DEFEAT THE PASSWORD WITHOUT USING A PDA TO EITHER READ THE PASSWORD OUT OR REPROGRAM A NEW ONE.

The Bank password can be disabled during initial programming by the PDA.



WARNING

DISABLING THE PASSWORD FUNCTION PUTS THE SYSTEM IN ACTIVE BANK SELECT. THIS ALLOWS THE CRANE OPERATOR TO SWITCH BETWEEN BANKS QUICKER. THE OPERATOR IN THIS MODE MUST BE AWARE AND RESPONSIBLE FOR ALL POSSIBLE CONTROLLED CRANES. FAILURE TO FOLLOW THIS WARNING COULD RESULT IN SERIOUS INJURY OR DEATH AND DAMAGE TO EQUIPMENT.

telePilot Time-Out-Timer Function.

The transmitter has a time-out timer and the default condition is 15 minutes. Upon timing out the transmitter will send an OFF command to the receiver if Auto Turn Off is active. The transmitter time-out-timer function is programmable in minute increments to up to and including 15 minutes. After that it is programmable in five-minute increments up to and including one hour. Infinite time-out (none) is also selectable. The time-out-timer measures the time since the last pushbutton stroke and is continuously reset by any pushbutton activation.

Section 5 – Operation (Continued)

5-7. Battery Replacement.

Membrane And Pendant Battery Replacement.

To replace the batteries, turn the transmitter OFF, and then turn the unit over to access back cover. Twist half moon shaped battery latch to remove cover. Take out old batteries; replace ALL batteries with new cells. For the Membrane Transmitter note battery orientation, batteries in backwards will blow fuse. Replace cover and turn transmitter ON to use. See Section 9. Spare Parts for battery and fuse part numbers.

telePilot Battery Replacement.

On the telePilot if the yellow battery indicator light  starts to flash replace the battery at the earliest opportunity. If the light is on solid replace the battery immediately.

NOTE

THERE IS NO NEED TO RUSH BATTERY REPLACEMENT. THE PROGRAMMING IN THE telePilot WILL NOT BE LOST BY REMOVAL OF THE BATTERY OR PROLONGED LOSS OF POWER.

Turn the transmitter OFF, loosen the two thumbscrews on the bottom of the unit and open the unit by pulling on the belt loop. (See below). Pull out the battery holder until the batteries can be accessed. Do not pull hard on the battery holder as it is attached to the logic board by a cable. Unsnap the battery cable (for battery packs) or replace the two “AA” cells (for a battery carrier) and replace the battery(s) with a new battery(s), noting the polarity for “AA” cells. (Best life can be obtained if the two “AA” batteries used are a good quality alkaline type, both cells of the same type and from the same manufacturer). Replace the battery holder, belt loop and tighten the thumbscrews. See Section 9 – Spare Parts for battery part numbers.

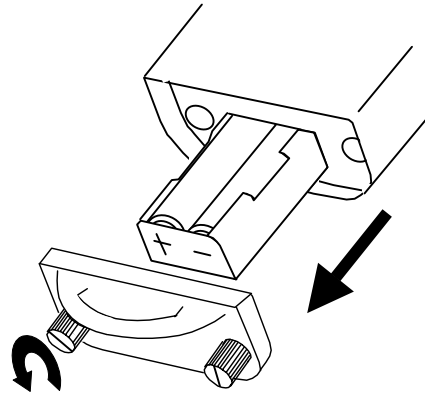

Figure 5-3. telePilot Battery Replacement.

Section 6 – Wiring

6-1. Wiring Diagrams.

Your *TELEPILOT* system comes pre-programmed the following pages in this section have individual wiring diagrams for different crane configurations. Find the appropriate wiring diagram and if necessary set the Configuration Switch (SW3 in the transmitter) to match the SW3 Transmitter Switch Settings shown in the appropriate diagram. The location of the SW3 for Membrane and Pendant transmitters is shown in Section 8-1. Servicing. Terminal designators are marked on the wiring diagram corresponding to designators found on the Receiver Board. For terminal locations see Figure 8-1. Receiver Layout.

After selecting the appropriate motors for each function remember to use the appropriate label on your *telePilot* transmitter for describing the appropriate command.

For the Pendant and Membrane transmitters the proper connections to use for the bridge and for the trolley are best determined by that pair of directional designators (North/South or East/West) best describes the crane's movement. Does the bridge travel East/West or North/South? The trolley would use the other directional pair as the bridge. Care should be taken after a directional pair is selected to make sure the specific motor directional inputs match the desired direction of the bridge or trolley, i.e., if North/South is picked for the bridge make sure the South traveling bridge motor directional is wired to the South terminal of the unit.

Typically in the following wiring diagrams, the bridge is shown as Motor 3 and Trolley as Motor 2. Since the labeling cannot be easily moved on the Membrane Transmitter keypad, the two directional pairs Motor 2 and 3 can be easily exchanged by turning the dip switch SW3 position 1 in the Membrane Transmitter to "ON". See Section 7-6.8. Repositioning of Membrane Transmitter Motion Switch Functions for more details.

6-2. Installation.

Follow Section 4. Installation Information for instructions on how to install the receiver.

6-3. Alarms And Horns.

Make sure that the installation includes the proper alarms, horns, indicator lights and their associated controls as required by local and governmental regulations.

6-4. Single-Speed Pendant Transmitter Wiring.

For the Single-Speed Pendant Transmitter the only wiring configuration is the diagram in Section 6. Wiring. Table 1, TR12 Single-Speed Standard Configuration Hoist, Trolley and Bridge.

6-5. 2-Speed Pendant Transmitter Wiring.

For the 2-Speed TR12 Pendant Transmitter the functional labeling is different than the 2-Speed Membrane. E/W and N/S are exchanged. By setting dip switch SW3 position 1 in the "ON" position the pushbuttons of the Pendant Transmitter match the directional notations on the 2-speed wiring diagrams in Section 6. Wiring. Failure to turn switch SW3 position 1 to "ON" will cause EAST/WEST and NORTH/SOUTH to be exchanged respectively. All other functions will remain the same.

6-6. Relay Sequencing.

When the second speed position is activated the appropriate directional relay is still engaged.

6-7. Alarm After E-STOP.

This is only for wiring configurations where the Aux 3 (relay K12, output J5-6) is being used for the Alarm function, placing a jumper on JU1 on the Receiver Board will allow the alarm to function after an E-STOP command. See Figure 8-1. Receiver Layout for jumper location.

6-8. Connecting Outputs To Drives.

MOV's (transient protectors) are on all the output relays to protect the relays from power surges. MOV's allow a small leakage current that can affect some high impedance circuits. When connecting output relays to drives, it may be required to remove the MOV to prevent the leakage current through the MOV from holding in the drive. See Figure 8-1. Receiver Layout for the location of the MOV's. The MOV's are next to the relays they protect. The MOV's can be cut

Section 6 – Wiring (Continued)

out of the circuit with a wire cutter. Remember to do this with ALL power OFF on the crane and all associated controls.

Legend

The following is the legend for the wiring diagrams below:

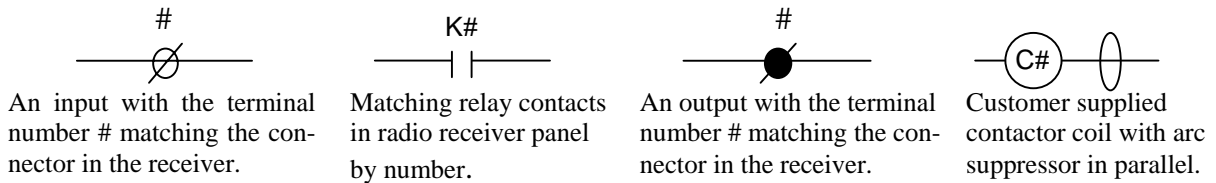

Figure 6-1. Legend.

6-9. Optional Transfer Switch Wiring Configurations.

If a transfer switch is desired, a simple schematic of an externally installed transfer switch interface is shown on the next page. A complete system drawing for this transfer switch is shown on the following pages (see Figure 6-3A.). A factory installed internal transfer switch is available. A system drawing for this optional factory installed internal transfer switch and pigtail is shown on the following pages (See Figure 6-3B.).

Section 6 – Wiring (Continued)

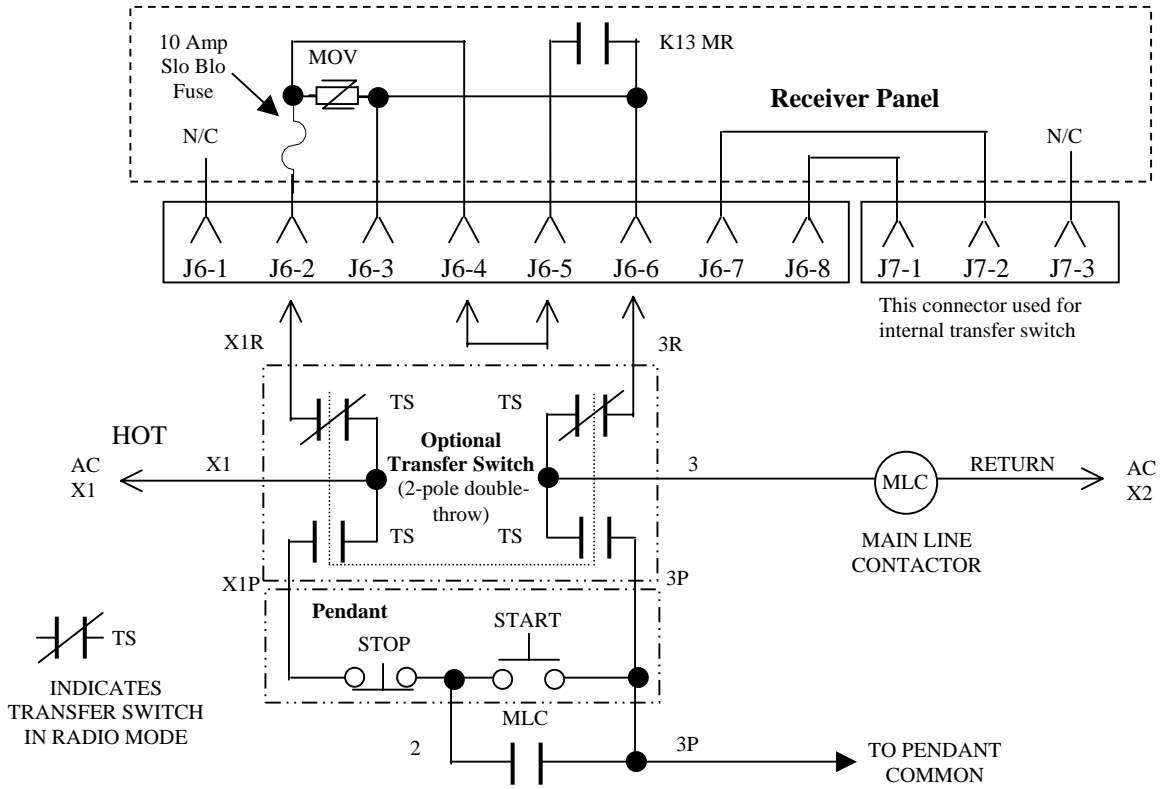
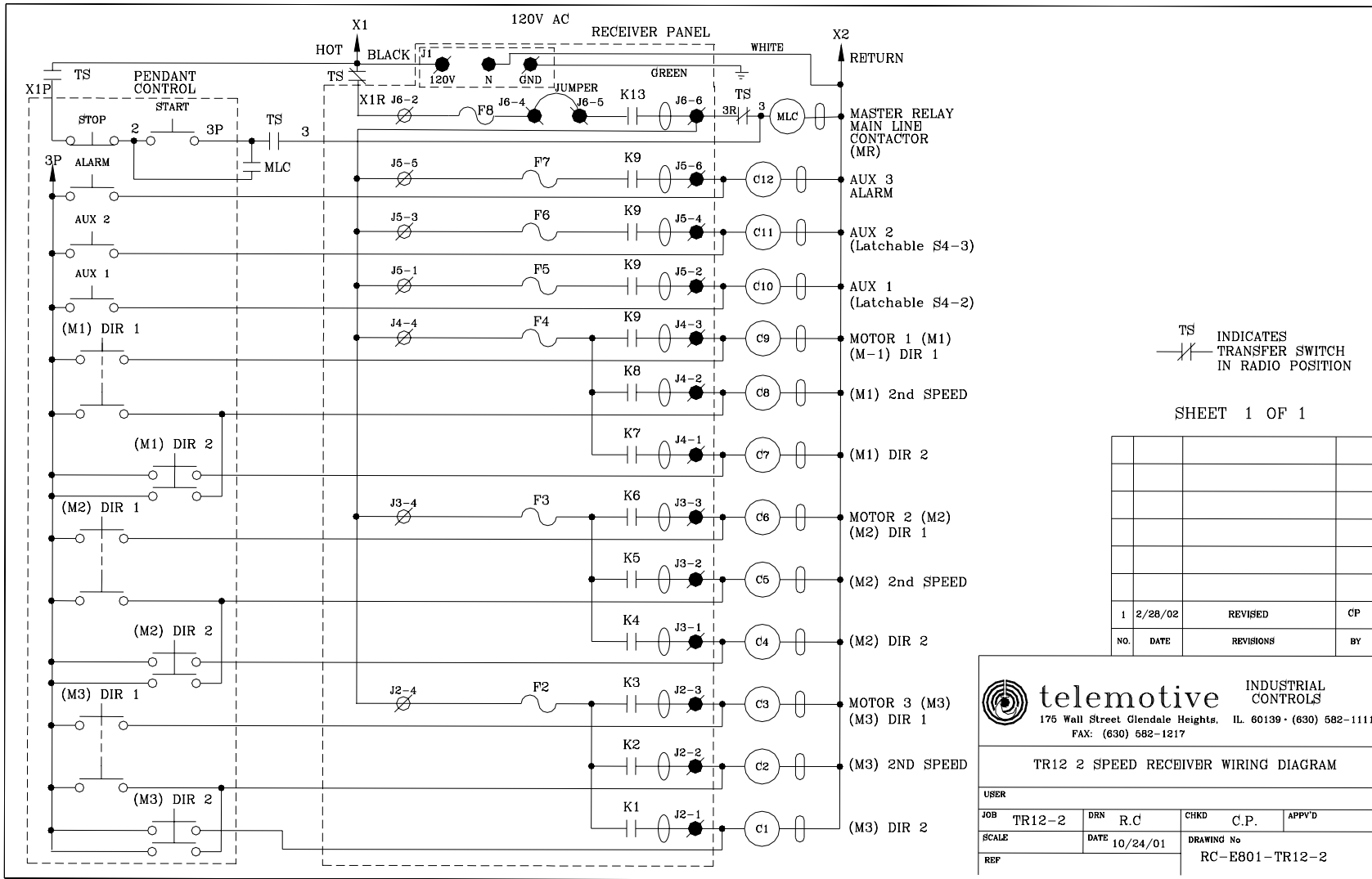

Figure 6-2. External Transfer Switch Wiring



TS INDICATES TRANSFER SWITCH IN RADIO POSITION

SHEET 1 OF 1

1	2/28/02	REVISED	CP
NO.	DATE	REVISIONS	BY

telemotive INDUSTRIAL CONTROLS
 175 Wall Street Glendale Heights, IL 60139 • (630) 582-1111
 FAX: (630) 582-1217

TR12 2 SPEED RECEIVER WIRING DIAGRAM

USER			
JOB	TR12-2	DRN	R.C.
SCALE	DATE	CHKD	C.P.
REP	10/24/01	APP'VD	
DRAWING No		RC-E801-TR12-2	

Figure 6-3A. External Transfer Switch System Wiring

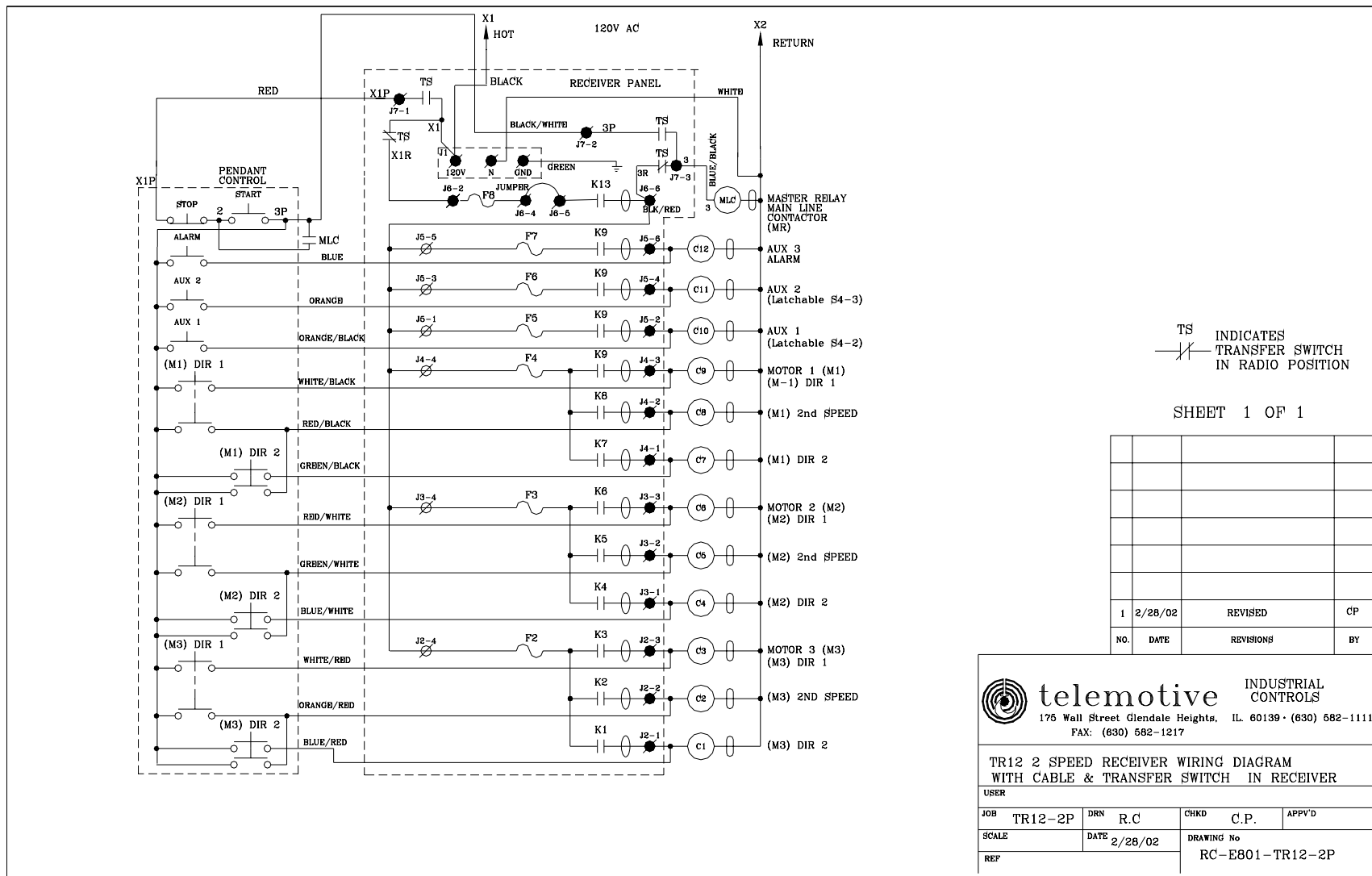

Figure 6-3B. Optional Internal Transfer Switch System Wiring

Section 6 - Wiring (Continued)

TS INDICATES TRANSFER SWITCH IN RADIO POSITION

SHEET 1 OF 1

NO.	DATE	REVISIONS	BY
1	2/28/02	REVISED	CP

telemotive INDUSTRIAL CONTROLS
 175 Wall Street Glendale Heights, IL 60139 • (630) 582-1111
 FAX: (630) 582-1217

TR12 2 SPEED RECEIVER WIRING DIAGRAM
 WITH CABLE & TRANSFER SWITCH IN RECEIVER

USER	DRN	CHKD	APP'VD
JOB TR12-2P	R.C	C.P.	
SCALE	DATE 2/28/02	DRAWING No	
REP		RC-E801-TR12-2P	

Section 6 - Wiring (Continued)

**TABLE 1 TR12 SINGLE-SPEED WIRING DIAGRAM.
STANDARD CONFIGURATION HOIST, TROLLEY AND BRIDGE**

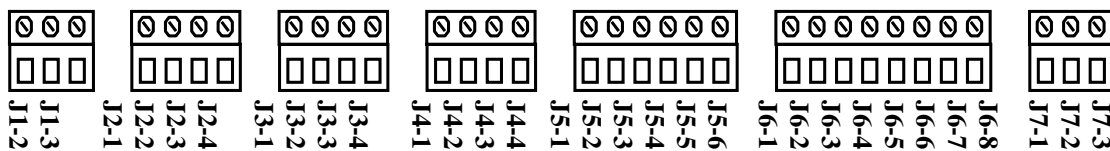
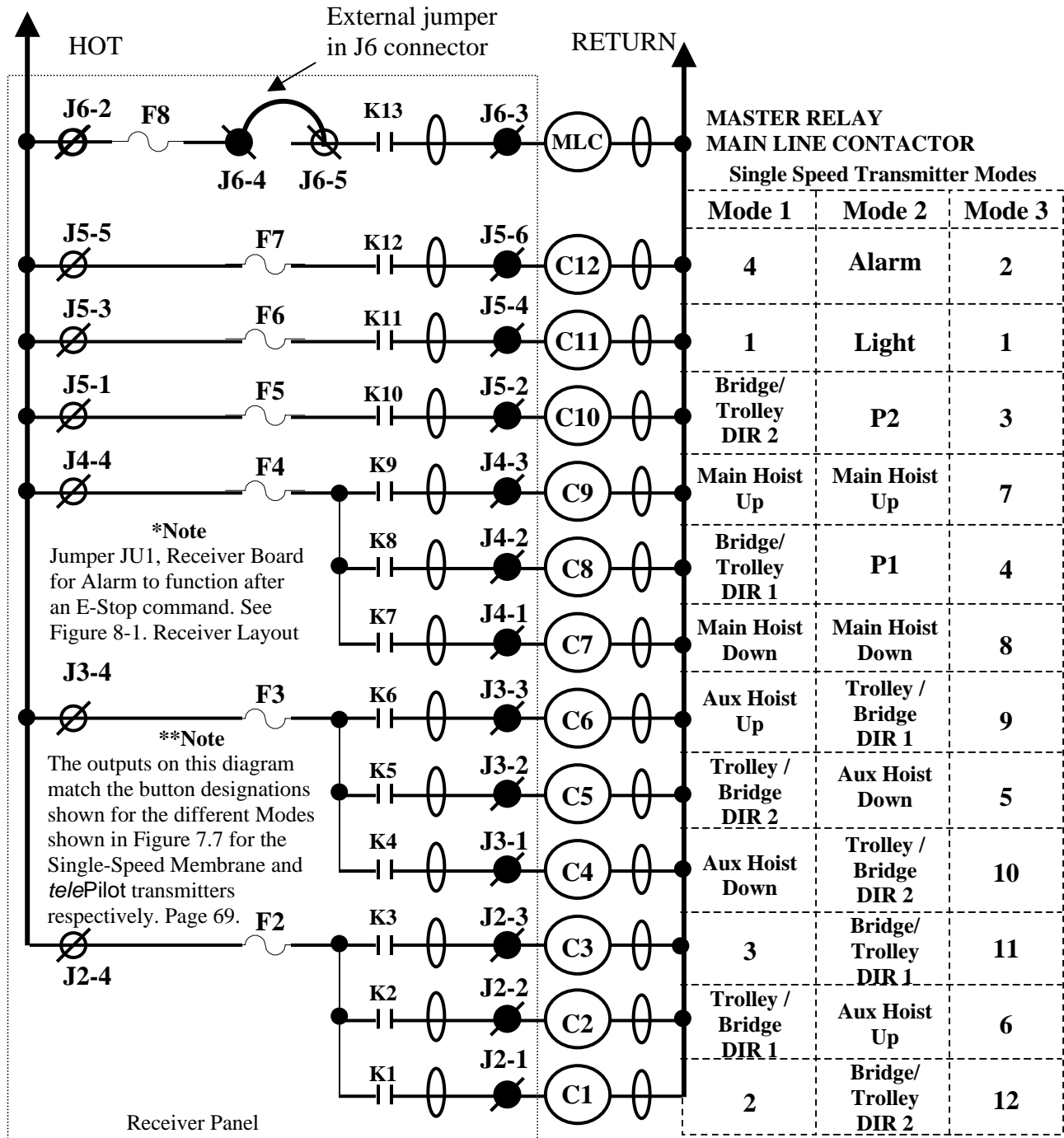

Section 6 - Wiring (Continued)

**TABLE 1 TR12 SINGLE-SPEED PROGRAMMING DIAGRAM.
STANDARD CONFIGURATION HOIST, TROLLEY AND BRIDGE**

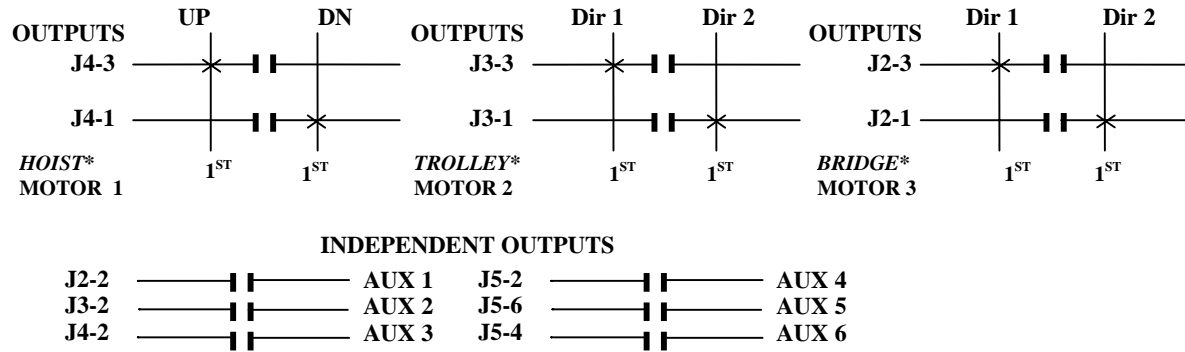

MOTOR 1 CONNECTIONS

J4-3 *HOIST* UP
 J4-1 *HOIST* DOWN
 J4-4 HOT (J4-1, 2 & 3)

MOTOR 2 CONNECTIONS

J3-3 *TROLLEY* DIR 1
 J3-1 *TROLLEY* DIR 2
 J3-4 HOT (J3-1, 2 & 3)

MOTOR 3 CONNECTIONS

J2-3 *BRIDGE* DIR 1
 J2-1 *BRIDGE* DIR 2
 J2-4 HOT (J2-1, 2 & 3)

INDEPENDENT CONNECTIONS

J4-2 AUX 3 (HOT J4-4) J3-2 AUX 2 (HOT J3-4) J2-2 AUX 1 (HOT J2-4)
 J5-2 AUX 4 (LATCHABLE S4-2) J5-1 HOT AUX 4
 J5-4 AUX 6 (LATCHABLE S4-3) J5-3 HOT AUX 6
 J5-6 AUX 5 ALARM J5-5 HOT AUX 5

RECEIVER SWITCH SETTINGS SW3:

**SW3 Position-5
ON**

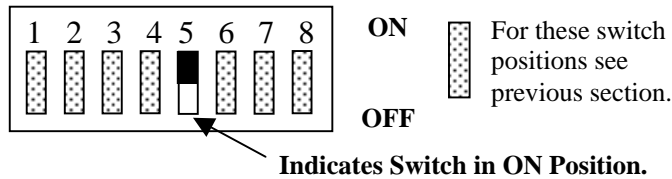

SINGLE SPEED ONLY TRANSMITTERS SWITCH SETTINGS

SINGLE SPEED *telePilot* USE PDA SCREEN (select single-speed transmitter style).

SINGLE SPEED MEMBRANE USE SW3 "C", SINGLE SPEED PENDANT USE SW "D"

TRANSMITTER SWITCH SETTINGS:

Position-5 OFF Position -6 OFF Position -7 OFF

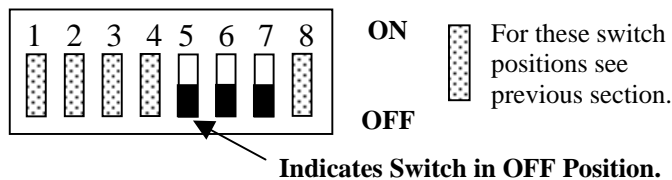

*NOTE: Hoist, Trolley and Bridge are listed here as traditional configurations, the installer may choose to define the motors differently.

Section 6 - Wiring (Continued)

**TABLE 2(A) TR12 2-SPEED WIRING DIAGRAM.
STANDARD CONFIGURATION HOIST, TROLLEY AND BRIDGE**

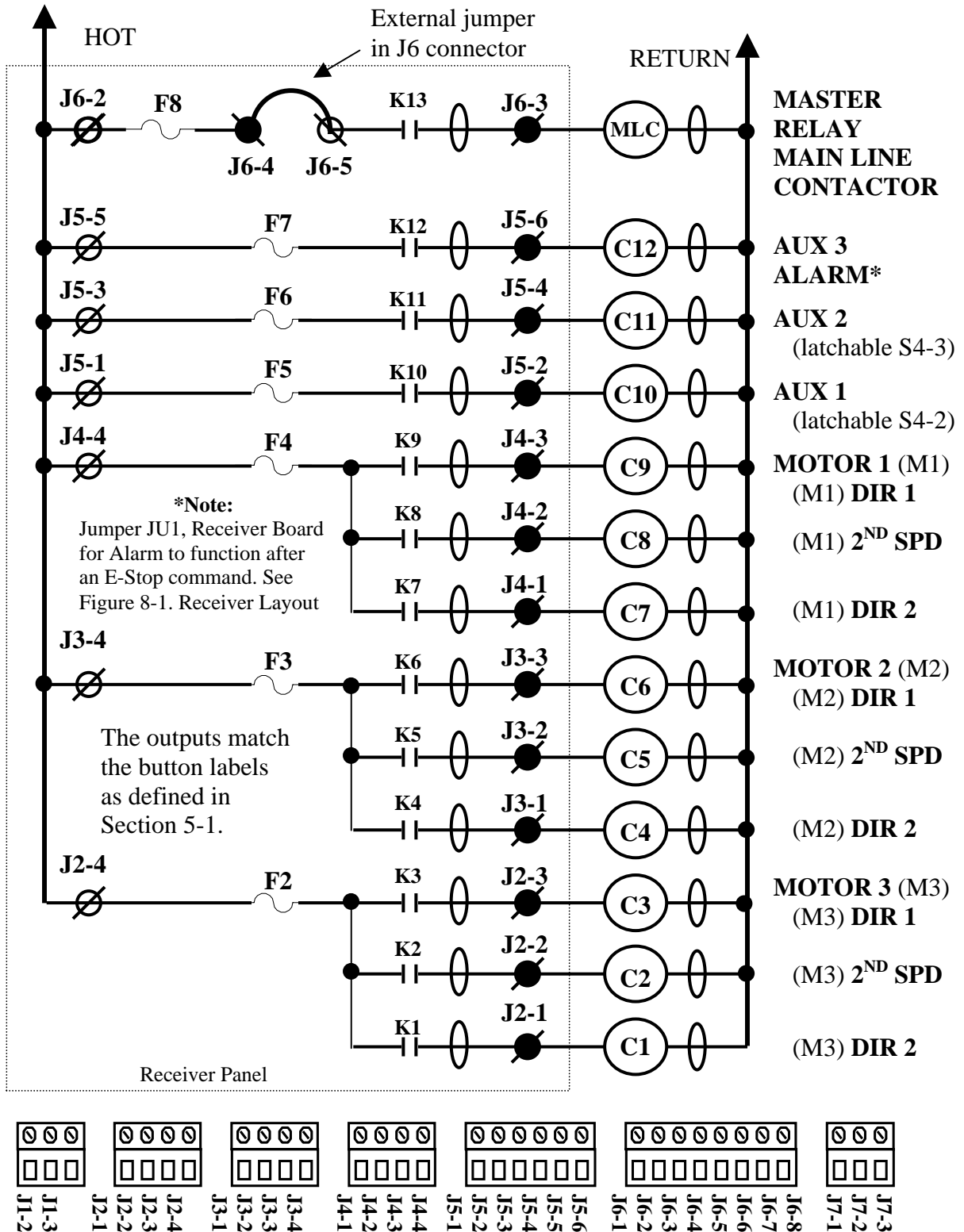

Section 6 - Wiring (Continued)

**TABLE 2(A) TR12 2-SPEED PROGRAMMING DIAGRAM.
STANDARD CONFIGURATION HOIST, TROLLEY AND BRIDGE**

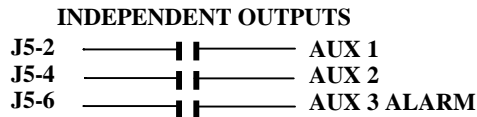
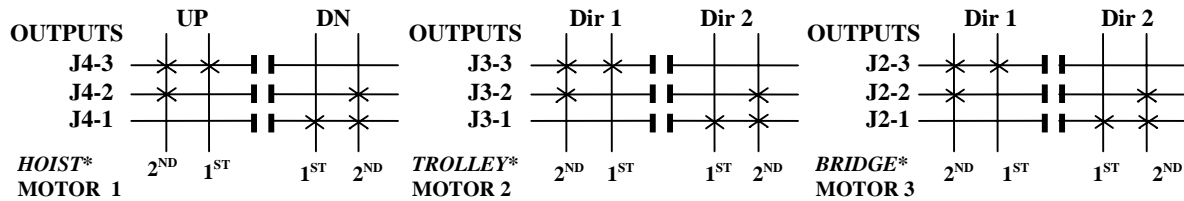

MOTOR 1 CONNECTIONS	MOTOR 2 CONNECTIONS	MOTOR 3 CONNECTIONS
J4-3 <i>HOIST</i> UP	J3-3 <i>TROLLEY</i> DIR 1	J2-3 <i>BRIDGE</i> DIR 1
J4-2 <i>HOIST</i> 2 ND SPEED	J3-2 <i>TROLLEY</i> 2 ND SPEED	J2-2 <i>BRIDGE</i> 2 ND SPEED
J4-1 <i>HOIST</i> DOWN	J3-1 <i>TROLLEY</i> DIR 2	J2-1 <i>BRIDGE</i> DIR 2
J4-4 HOT (J4-1, 2 & 3)	J3-4 HOT (J3-1, 2 & 3)	J2-4 HOT (J2-1, 2 & 3)

INDEPENDENT CONNECTIONS

J5-2 AUX 1 (LATCHABLE S4-2)	J5-1 HOT AUX 1
J5-4 AUX 2 (LATCHABLE S4-3)	J5-3 HOT AUX 2
J5-6 AUX 3 ALARM	J5-5 HOT AUX 3 ALARM

TRANSMITTER SWITCH SETTINGS

telePilot USE PDA SCREEN (Program the configuration switches 5, 6 and 7 to OFF. Under “Main/Aux” select the setting “Aux”).

MEMBRANE USE SW3 “C”

PENDANT, JLTx AND SLTx USE SW4 “D”

TRANSMITTER SWITCH SETTINGS:

Position-5	Position -6	Position -7
OFF	OFF	OFF

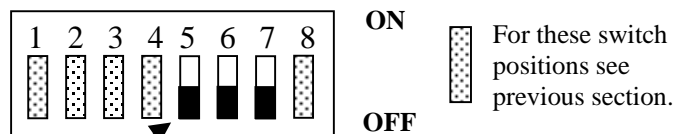

Indicates Switch in OFF Position.

*NOTE: Hoist, Trolley and Bridge are listed here as traditional configurations, the installer may choose to define the motors differently.

Section 6 - Wiring (Continued)

TABLE 2(B) TR12 2-SPEED WIRING DIAGRAM.
2-SPEED with DIRECTIONAL CONTROLS: ALL MOTIONS

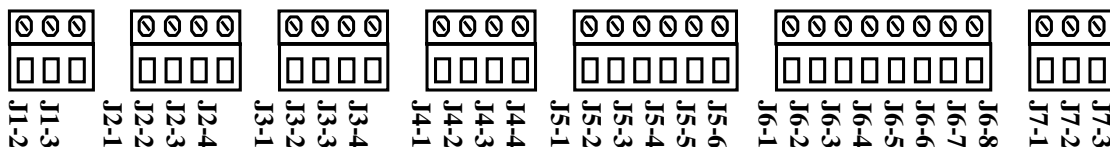
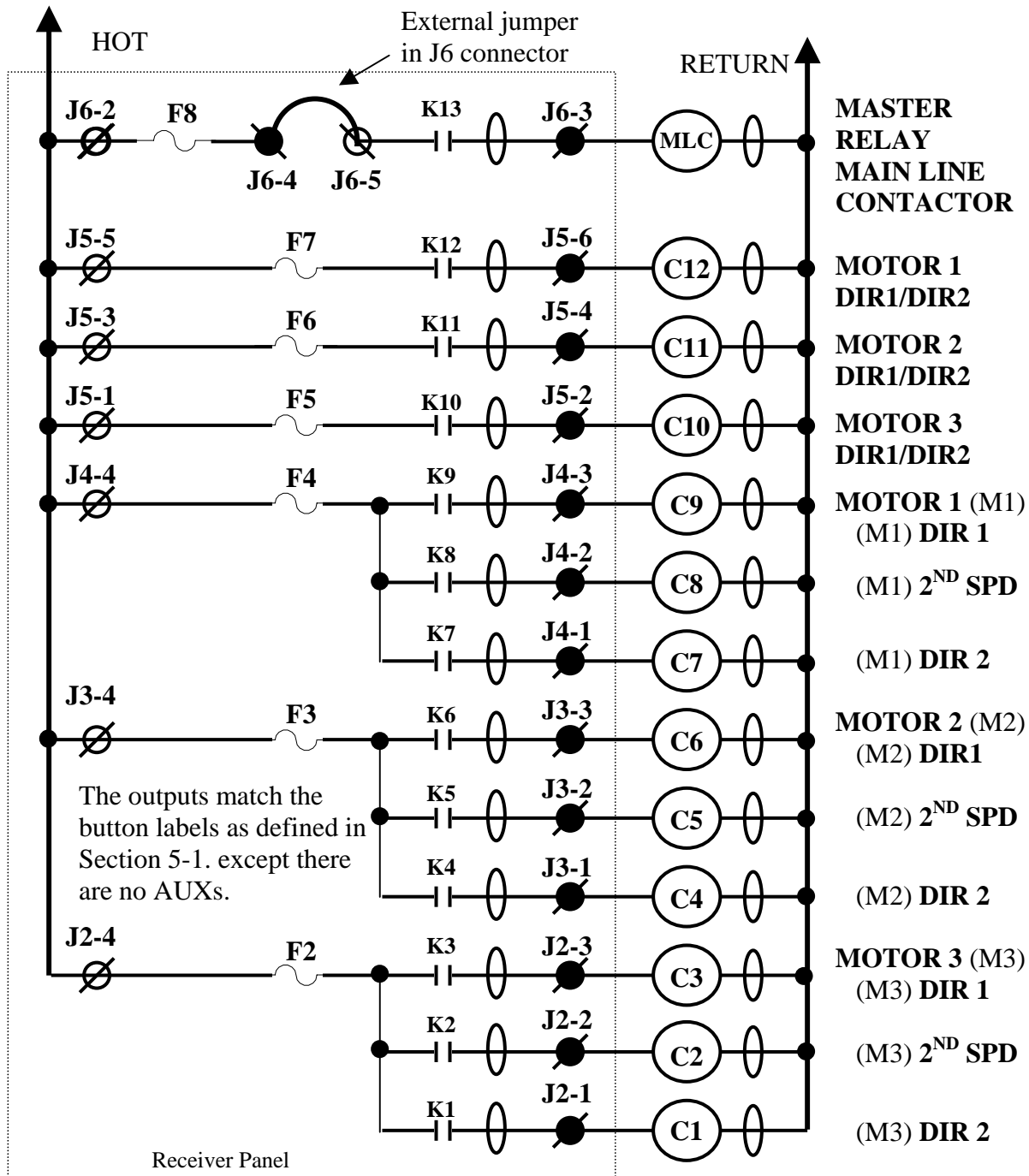

Section 6 - Wiring (Continued)

**TABLE 2(B) TR12 2-SPEED PROGRAMMING DIAGRAM.
2-SPEED with DIRECTIONAL CONTROLS: ALL MOTIONS**

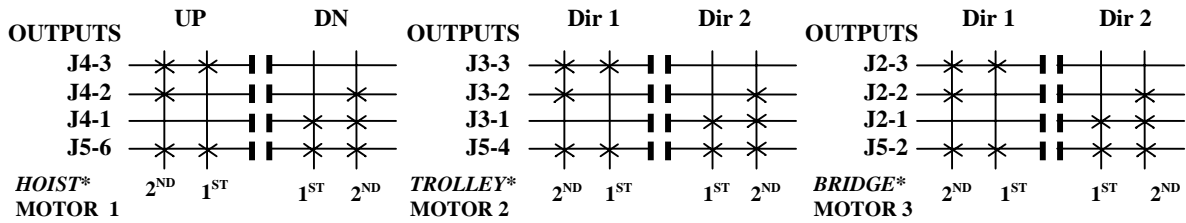

MOTOR 1 CONNECTIONS

J4-3 *HOIST* UP
 J4-2 *HOIST* 2ND SPEED
 J4-1 *HOIST* DOWN
 J4-4 HOT (J4-1, 2 & 3)
 J5-6 *HOIST* DIR1/DIR2
 J5-5 HOT *HOIST* DIR1/DIR2

MOTOR 2 CONNECTIONS

J3-3 *TROLLEY* DIR 1
 J3-2 *TROLLEY* 2ND SPEED
 J3-1 *TROLLEY* DIR 2
 J3-4 HOT (J3-1, 2 & 3)
 J5-4 *TROLLEY* DIR1/DIR2
 J5-3 HOT *TROLLEY* DIR1/DIR2

MOTOR 3 CONNECTIONS

J2-3 *BRIDGE* DIR 1
 J2-2 *BRIDGE* 2ND SPEED
 J2-1 *BRIDGE* DIR 2
 J2-4 HOT (J2-1, 2 & 3)
 J5-2 *BRIDGE* DIR1/DIR2
 J5-1 HOT *BRIDGE* DIR1/DIR2

NOTE

CHECK GOVERNMENTAL AND LOCAL REGULATIONS ON THE REQUIREMENTS OF HORNS OR ALARMS BEFORE USING THIS CONFIGURATION, AS THERE IS NOT A SEPARATE ALARM CONTROL.

TRANSMITTER SWITCH SETTINGS

telePilot USE PDA SCREEN (Program the configuration switches 5, 6 & 7 to match the settings shown below).

MEMBRANE USE SW3 “C”

PENDANT, JLTX AND SLTX USE SW4 “D”

TRANSMITTER SWITCH SETTINGS:

Position-5

Position -6

Position -7

ON

OFF

OFF

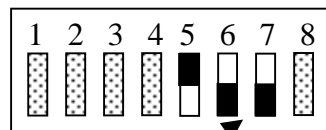

ON

OFF

For these switch positions see previous section.

Indicates Switch in OFF Position.

*NOTE: Hoist, Trolley and Bridge are listed here as traditional configurations, the installer may choose to define the motors differently.

Section 6 - Wiring (Continued)

**TABLE 2(C) TR12 2-SPEED WIRING DIAGRAM.
2-SPEED, 2-WINDINGS: ALL MOTIONS**

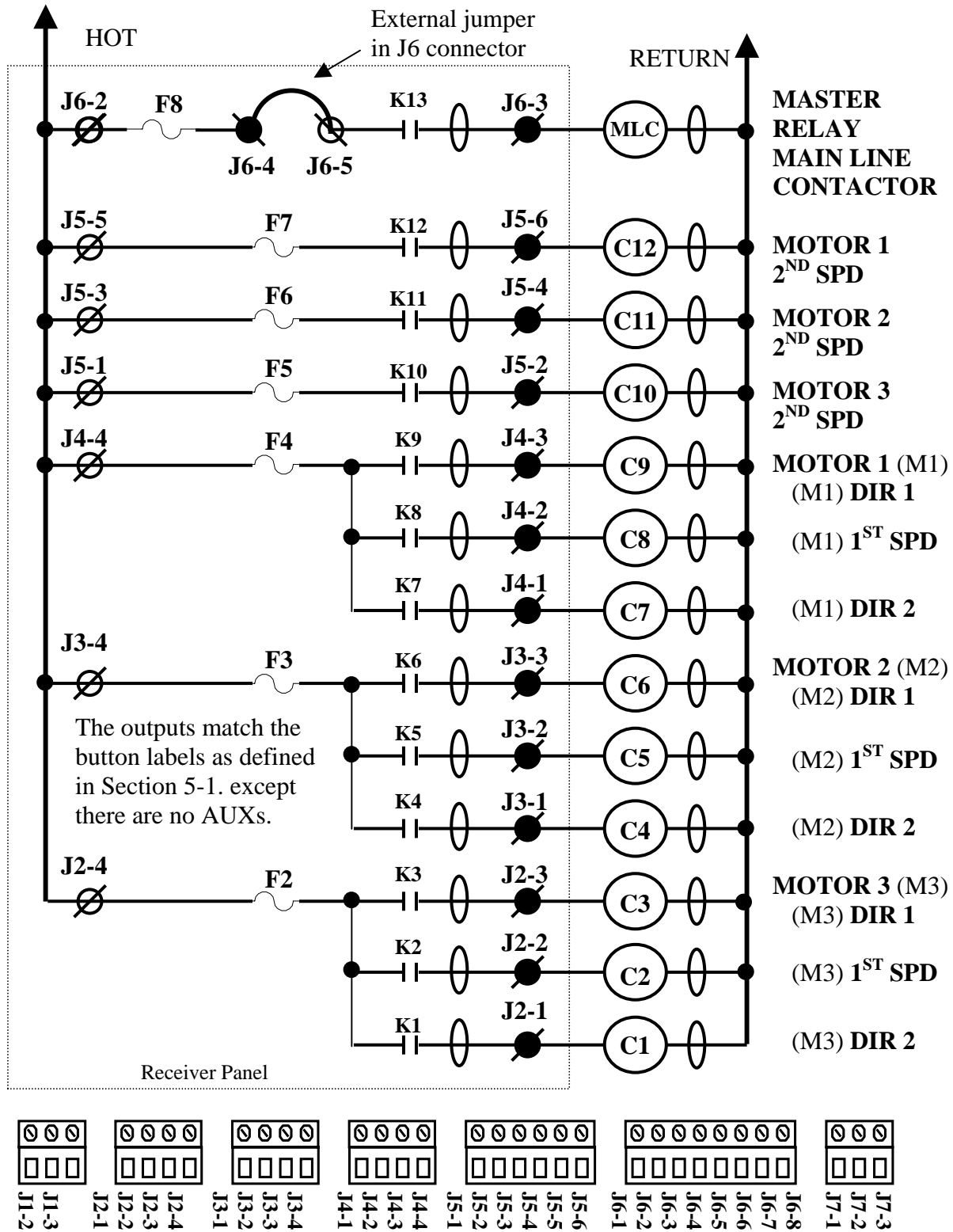

Section 6 - Wiring (Continued)

**TABLE 2(C) TR12 2-SPEED PROGRAMMING DIAGRAM.
2-SPEED, 2-WINDINGS: ALL MOTIONS**

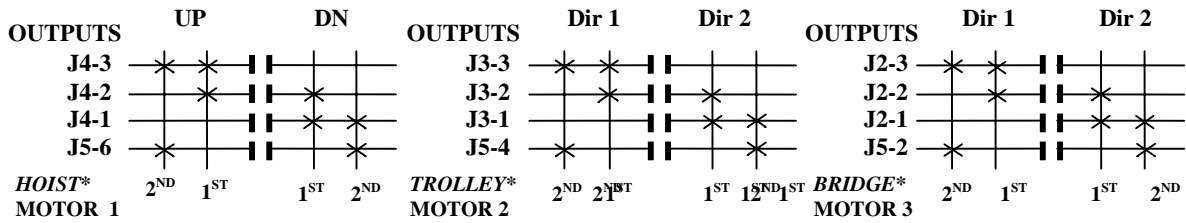

MOTOR 1 CONNECTIONS

J4-3 *HOIST* UP
 J4-2 *HOIST* 1ST SPEED
 J4-1 *HOIST* DOWN
 J4-4 HOT (J4-1, 2 & 3)
 J5-6 *HOIST* 2ND SPEED
 J5-5 HOT *HOIST* 2ND SPEED

MOTOR 2 CONNECTIONS

J3-3 *TROLLEY* DIR 1
 J3-2 *TROLLEY* 1ST SPEED
 J3-1 *TROLLEY* DIR 2
 J3-4 HOT (J3-1, 2 & 3)
 J5-4 *TROLLEY* 2ND SPEED
 J5-3 HOT *TROLLEY* 2ND SPEED

MOTOR 3 CONNECTIONS

J2-3 *BRIDGE* DIR 1
 J2-2 *BRIDGE* 1ST SPEED
 J2-1 *BRIDGE* DIR 2
 J2-4 HOT (J2-1, 2 & 3)
 J5-2 *BRIDGE* 2ND SPEED
 J5-1 HOT *BRIDGE* 2ND SPEED

NOTE

CHECK GOVERNMENTAL AND LOCAL REGULATIONS ON THE REQUIREMENTS OF HORNS OR ALARMS BEFORE USING THIS CONFIGURATION, AS THERE IS NOT A SEPARATE ALARM CONTROL.

TRANSMITTER SWITCH SETTINGS

telePilot USE PDA SCREEN (Program the configuration switches to match the pattern and position shown).

MEMBRANE USE SW3 “C”

PENDANT, JLTX AND SLTX USE SW4 “D”

TRANSMITTER SWITCH SETTINGS:

Position-5	Position -6	Position -7
OFF	ON	OFF

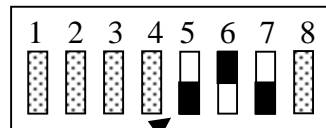

ON For these switch positions see previous section.
 OFF

Indicates Switch in OFF Position.

*NOTE: Hoist, Trolley and Bridge are listed here as traditional configurations, the installer may choose to define the motors differently.

Section 6 - Wiring (Continued)

**TABLE 2(D) TR12 2-SPEED WIRING DIAGRAM.
ACCO CONTROLS: ALL MOTIONS**

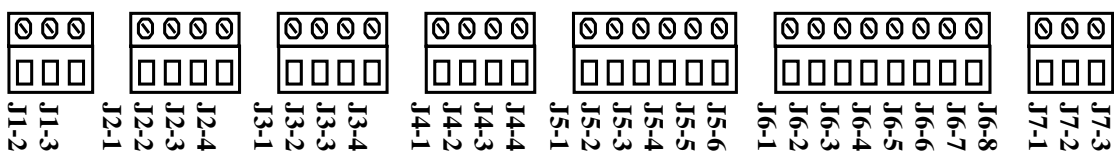
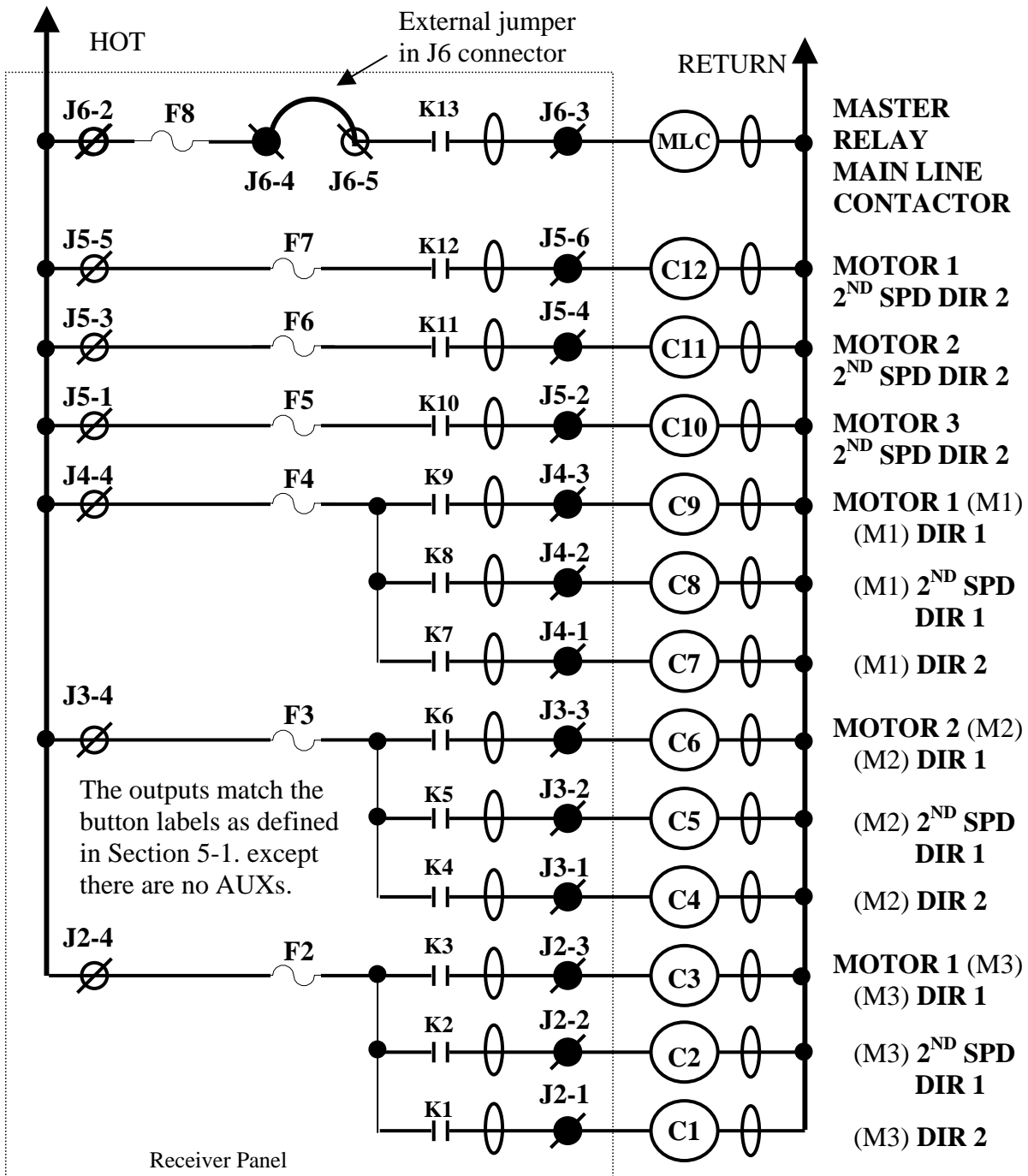

Section 6 - Wiring (Continued)

**TABLE 2(D) TR12 2-SPEED PROGRAMMING DIAGRAM.
ACCO CONTROLS: ALL MOTIONS**

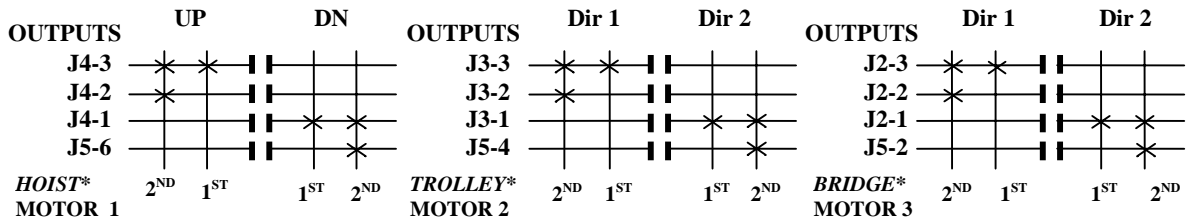

MOTOR 1 CONNECTIONS

J4-3 *HOIST* UP
 J4-2 *HOIST* 2ND SPEED DIR 1
 J4-1 *HOIST* DOWN
 J4-4 HOT (J4-1, 2 & 3)
 J5-6 *HOIST* 2ND SPEED DIR 2
 J5-5 HOT *HOIST* 2ND SPD DIR 2

MOTOR 2 CONNECTIONS

J3-3 *TROLLEY* DIR 1
 J3-2 *TROLLEY* 2ND SPEED DIR 1
 J3-1 *TROLLEY* DIR 2
 J3-4 HOT (J3-1, 2 & 3)
 J5-4 *TROLLEY* 2ND SPEED DIR 2
 J5-3 HOT *TROLLEY* 2ND SPD DIR 2

MOTOR 3 CONNECTIONS

J2-3 *BRIDGE* DIR 1
 J2-2 *BRIDGE* 2ND SPEED DIR 1
 J2-1 *BRIDGE* DIR 2
 J2-4 HOT (J2-1, 2 & 3)
 J5-2 *BRIDGE* 2ND SPEED DIR 2
 J5-1 HOT *BRIDGE* 2ND SPD DIR 2

NOTE

CHECK GOVERNMENTAL AND LOCAL REGULATIONS ON THE REQUIREMENTS OF HORNS OR ALARMS BEFORE USING THIS CONFIGURATION, AS THERE IS NOT A SEPARATE ALARM CONTROL.

TRANSMITTER SWITCH SETTINGS

telePilot USE PDA SCREEN (Program the configuration switches 5, 6 & 7 to match the settings shown below).

MEMBRANE USE SW3 "C"

PENDANT, JLTX AND SLTX USE SW4 "D"

TRANSMITTER SWITCH SETTINGS:

Position-5

Position -6

Position -7

ON

ON

OFF

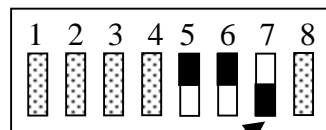

ON

OFF

For these switch positions see previous section.

Indicates Switch in OFF Position.

*NOTE: Hoist, Trolley and Bridge are listed here as traditional configurations, the installer may choose to define the motors differently.

Section 6 - Wiring (Continued)

TABLE 2(E) TR12 2-SPEED WIRING DIAGRAM.
P&H: 2-SPEED, 2-WINDINGS for HOIST and TROLLEY;
STANDARD BRIDGE

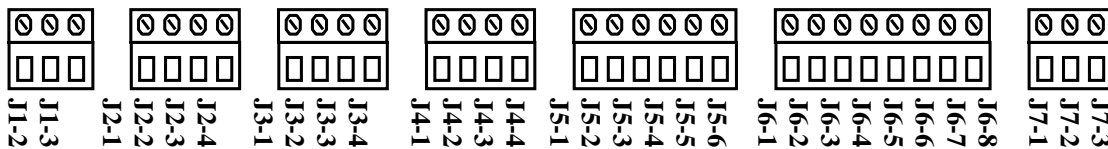
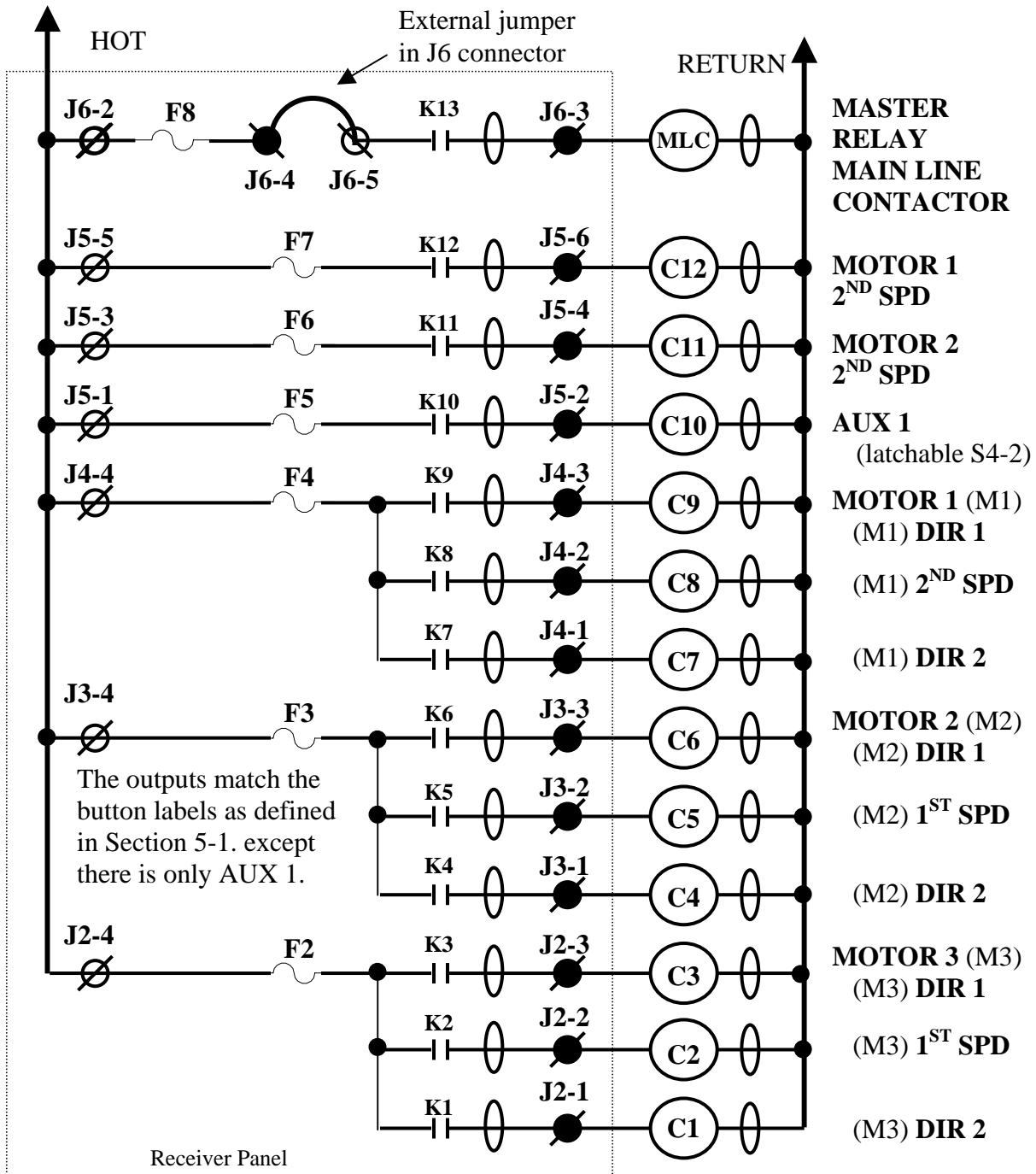

Section 6 - Wiring (Continued)

**TABLE 2(E) TR12 2-SPEED PROGRAMMING DIAGRAM.
P&H: 2-SPEED, 2-WINDINGS for HOIST and TROLLEY;
STANDARD BRIDGE**

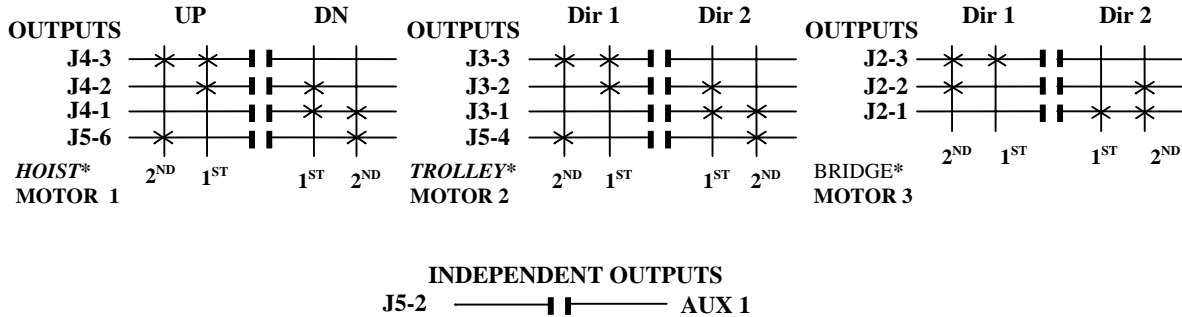

MOTOR 1 CONNECTIONS

- J4-3 *HOIST* UP
- J4-2 *HOIST* 1ST SPEED
- J4-1 *HOIST* DOWN
- J4-4 HOT (J4-1, 2 & 3)
- J5-6 *HOIST* 2ND SPEED
- J5-5 HOT *HOIST* 2ND SPEED

MOTOR 2 CONNECTIONS

- J3-3 *TROLLEY* DIR 1
- J3-2 *TROLLEY* 1ST SPEED
- J3-1 *TROLLEY* DIR 2
- J3-4 HOT (J3-1, 2 & 3)
- J5-4 *TROLLEY* 2ND SPEED
- J5-3 HOT *TROLLEY* 2ND SPEED

MOTOR 3 CONNECTIONS

- J2-3 *BRIDGE* DIR 1
- J2-2 *BRIDGE* 2ND SPEED
- J2-1 *BRIDGE* DIR 2
- J2-4 HOT (J2-1, 2 & 3)

INDEPENDENT CONNECTIONS

- J5-2 AUX 1 (LATCHABLE S4-2)
- J5-1 HOT AUX 1

TRANSMITTER SWITCH SETTINGS

telePilot USE PDA SCREEN (Program the configuration switches 5, 6 & 7 to match the settings shown below).

MEMBRANE USE SW3 “C”

PENDANT, JLTX AND SLTX USE SW4 “D”

TRANSMITTER SWITCH SETTINGS:

Position-5	Position -6	Position -7
OFF	OFF	ON

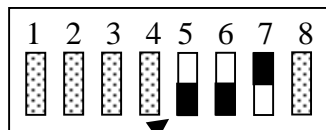

ON For these switch positions see previous section.

OFF

Indicates Switch in OFF Position.

*NOTE: Hoist, Trolley and Bridge are listed here as traditional configurations, the installer may choose to define the motors differently.

Section 6 - Wiring (Continued)

TABLE 2(F) TR12 2-SPEED WIRING DIAGRAM.
P&H: 2-SPEED, 2-WINDINGS for HOIST;
STANDARD TROLLEY and BRIDGE

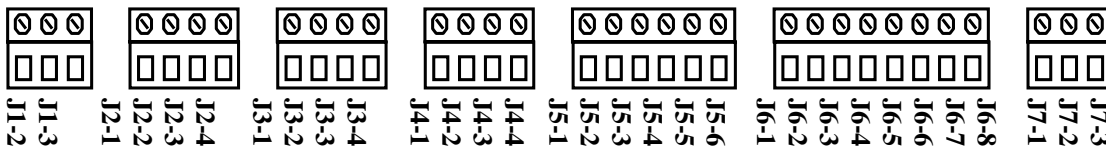
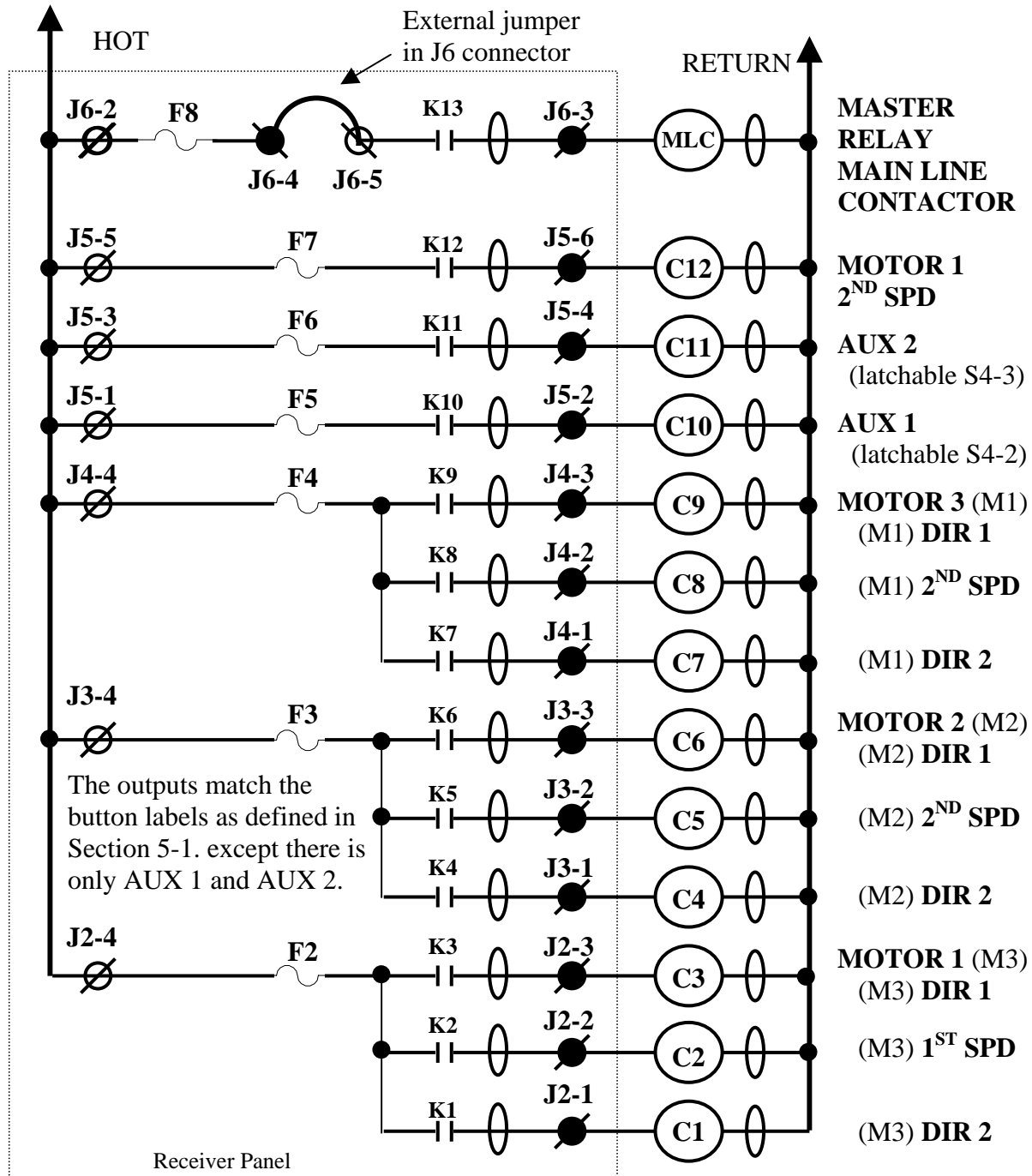

Section 6 - Wiring (Continued)

**TABLE 2(F) TR12 2-SPEED PROGRAMMING DIAGRAM.
P&H: 2-SPEED, 2-WINDINGS for HOIST;
STANDARD TROLLEY and BRIDGE**

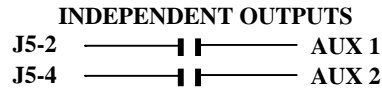
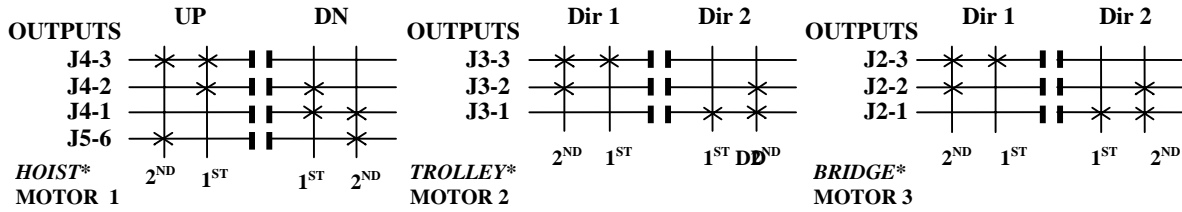

MOTOR 1 CONNECTIONS

- J4-3 *HOIST* UP
- J4-2 *HOIST* 1ST SPEED
- J4-1 *HOIST* DOWN
- J4-4 HOT (J4-1, 2 & 3)
- J5-6 *HOIST* 2ND SPD
- J5-5 HOT *HOIST* 2ND SPEED

MOTOR 2 CONNECTIONS

- J3-3 *TROLLEY* DIR 1
- J3-2 *TROLLEY* 2ND SPEED
- J3-1 *TROLLEY* DIR 2
- J3-4 HOT (J3-1, 2 & 3)

MOTOR 3 CONNECTIONS

- J2-3 *BRIDGE* DIR 1
- J2-2 *BRIDGE* 2ND SPEED
- J2-1 *BRIDGE* DIR 2
- J2-4 HOT (J2-1, 2 & 3)

INDEPENDENT CONNECTIONS

- | | |
|-----------------------------|----------------|
| J5-2 AUX 1 (LATCHABLE S4-2) | J5-1 HOT AUX 1 |
| J5-4 AUX 2 (LATCHABLE S4-3) | J5-3 HOT AUX 2 |

TRANSMITTER SWITCH SETTINGS

telePilot USE PDA SCREEN (Program the configuration switches 5, 6 & 7 to match the settings shown below).

MEMBRANE USE SW3 “C”

PENDANT, JLTx AND SLTx USE SW4 “D”

TRANSMITTER SWITCH SETTINGS:

Position-5	Position -6	Position -7
ON	OFF	ON

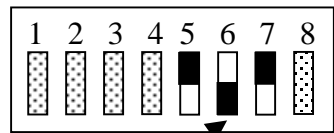
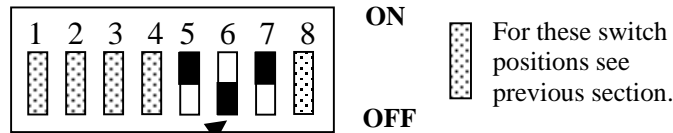

Indicates Switch in OFF Position.

*NOTE: Hoist, Trolley and Bridge are listed here as traditional configurations, the installer may choose to define the motors differently.

Section 6 - Wiring (Continued)

**TABLE 2(G) TR12 2-SPEED WIRING DIAGRAM.
DEMAG: 2-SPEED, 2-WINDINGS for HOIST;
STANDARD TROLLEY and BRIDGE**

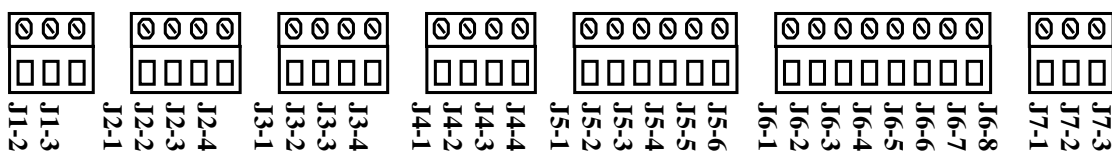
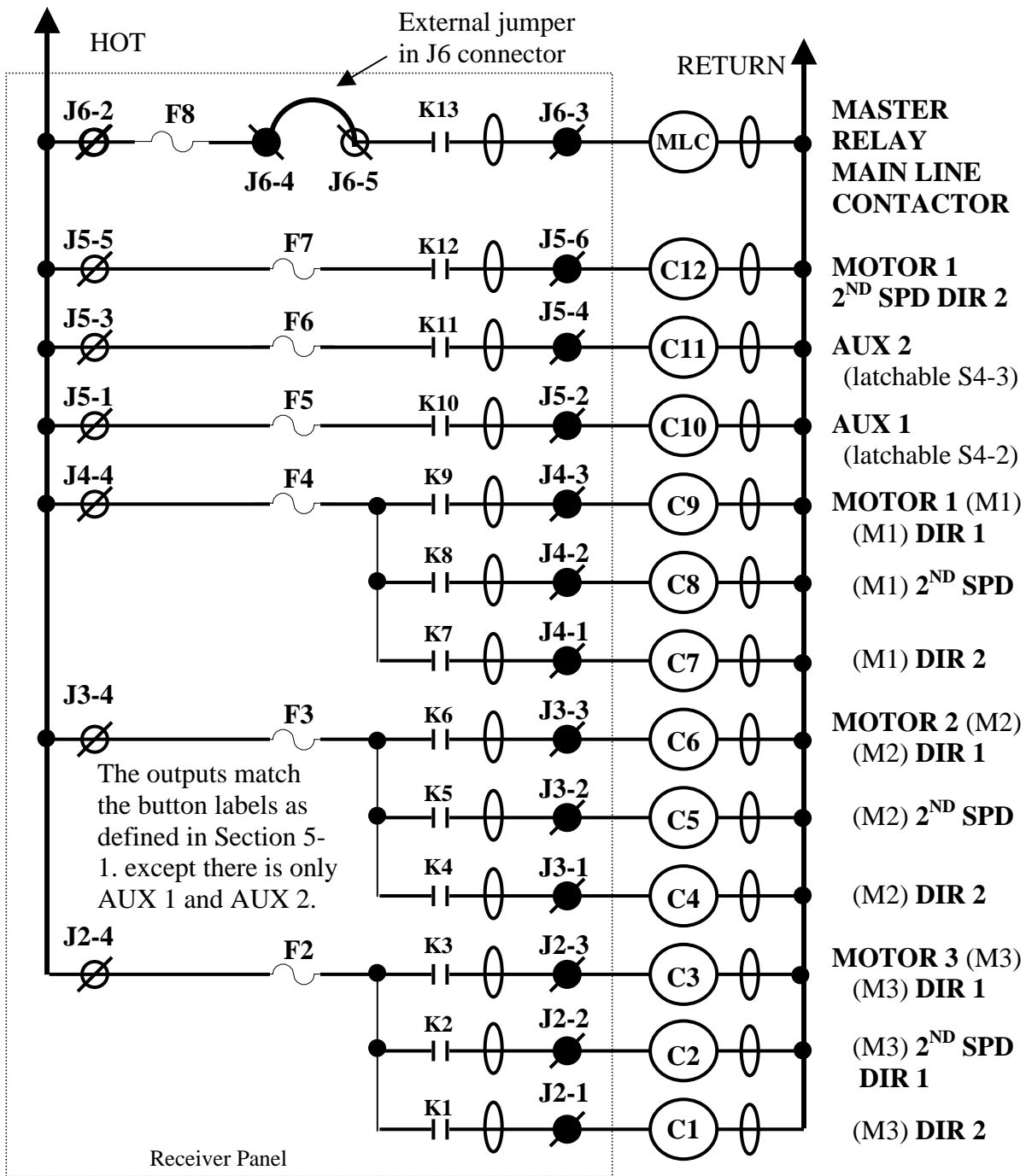

Section 6 - Wiring (Continued)

**TABLE 2(G) TR12 2-SPEED PROGRAMMING DIAGRAM.
DEMAG: 2-SPEED, 2-WINDINGS for HOIST;
STANDARD TROLLEY and BRIDGE**

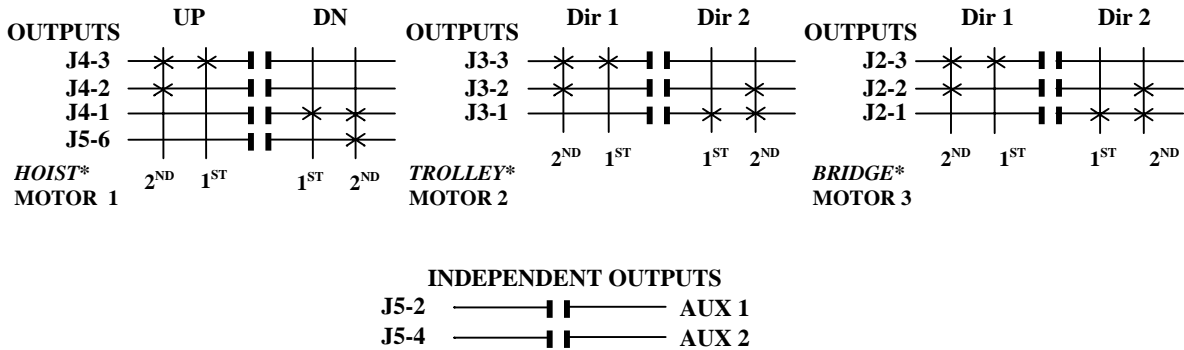

MOTOR 1 CONNECTIONS

J4-3 *HOIST* UP
 J4-2 *HOIST* 2ND SPEED DIR 1
 J4-1 *HOIST* DOWN
 J4-4 HOT (J4-1, 2 & 3)
 J5-6 *HOIST* 2ND SPEED DIR 2
 J5-5 HOT *HOIST* 2ND SPEED DIR 2

MOTOR 2 CONNECTIONS

J3-3 *TROLLEY* DIR 1
 J3-2 *TROLLEY* 2ND SPEED
 J3-1 *TROLLEY* DIR 2
 J3-4 HOT (J3-1, 2 & 3)

MOTOR 3 CONNECTIONS

J2-3 *BRIDGE* DIR 1
 J2-2 *BRIDGE* 2ND SPEED
 J2-1 *BRIDGE* DIR 2
 J2-4 HOT (J2-1, 2 & 3)

INDEPENDENT CONNECTIONS

J5-2 AUX 1 (LATCHABLE S4-2) J5-1 HOT AUX 1
 J5-4 AUX 2 (LATCHABLE S4-3) J5-3 HOT AUX 2

TRANSMITTER SWITCH SETTINGS

telePilot USE PDA SCREEN (Program the configuration switches 5, 6 & 7 to match the settings shown below).

MEMBRANE USE SW3 "C"

PENDANT, JLTX AND SLTX USE SW4 "D"

TRANSMITTER SWITCH SETTINGS:

Position-5

Position -6

Position -7

OFF

ON

ON



ON

OFF

For these switch positions see previous section.

Indicates Switch in OFF Position.

*NOTE: Hoist, Trolley and Bridge are listed here as traditional configurations, the installer may choose to define the motors differently.

Section 6 - Wiring (Continued)

**TABLE 2(H) TR12 2-SPEED WIRING DIAGRAM.
STANDARD 2-SPEED 4 MOTOR SYSTEM**

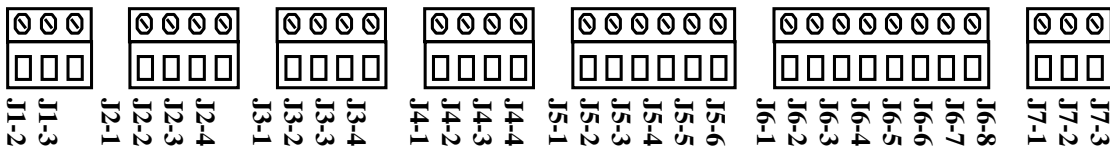
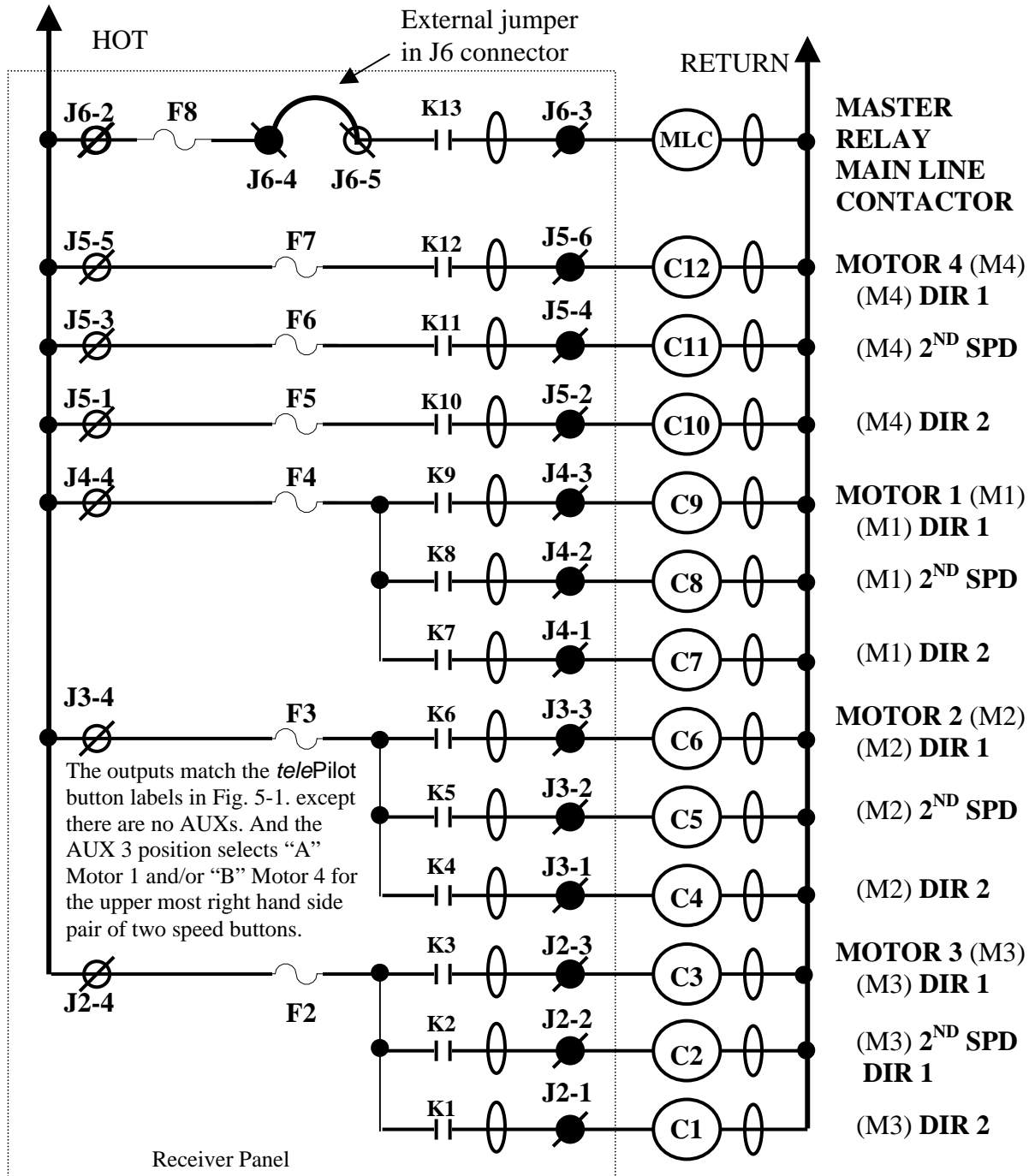

Section 6 - Wiring (Continued)

**TABLE 2(H) TR12 2-SPEED PROGRAMMING DIAGRAM.
STANDARD 2-SPEED 4 MOTOR SYSTEM**

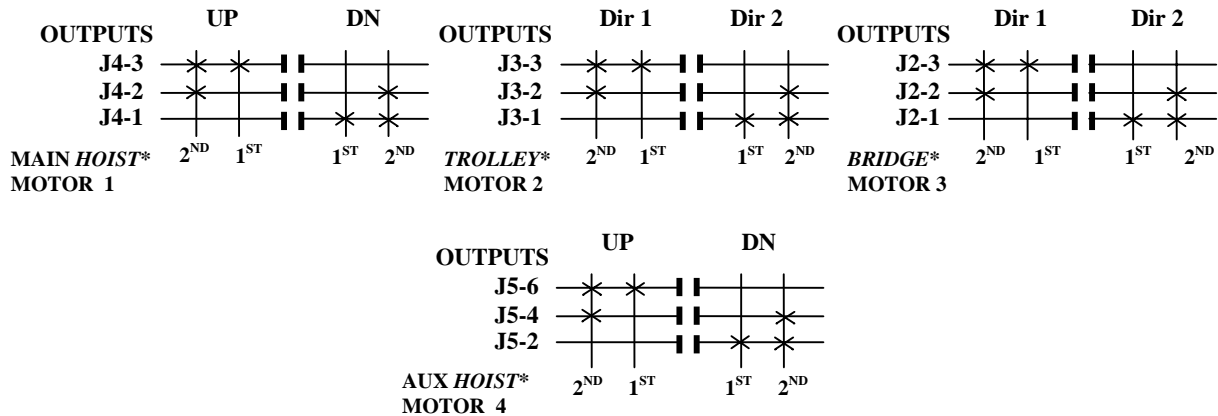

MOTOR 1 CONNECTIONS

J4-3 MAIN HOIST UP
 J4-2 MAIN HOIST 2ND SPEED
 J4-1 MAIN HOIST DOWN
 J4-4 HOT (J4-1, 2 & 3)

MOTOR 2 CONNECTIONS

J3-3 TROLLEY DIR 1
 J3-2 TROLLEY 2ND SPEED
 J3-1 TROLLEY DIR 2
 J3-4 HOT (J3-1, 2 & 3)

MOTOR 3 CONNECTIONS

J2-3 BRIDGE DIR 1
 J2-2 BRIDGE 2ND SPEED
 J2-1 BRIDGE DIR 2
 J2-4 HOT (J2-1, 2 & 3)

MOTOR 4 CONNECTIONS

J5-6 AUX HOIST UP
 J5-4 AUX HOIST 2ND SPEED
 J5-2 AUX HOIST DOWN
 J5-5 HOT AUX HOIST UP
 J5-3 HOT AUX HOIST 2ND SPEED
 J5-1 HOT AUX HOIST DOWN

NOTE

CHECK GOVERNMENTAL AND LOCAL REGULATIONS ON THE REQUIREMENTS OF HORNS OR ALARMS BEFORE USING THIS CONFIGURATION, AS THERE IS NOT A SEPARATE ALARM CONTROL.

TRANSMITTER SWITCH SETTINGS (This configuration does not apply to the Membrane transmitter).

telePilot USE PDA SCREEN (Program the configuration switches 5, 6 and 7 to OFF. Under “Main/Aux” select the setting “Motor”).

PENDANT, JLTX AND SLTX TRANSMITTER SWITCH SW4 “D” SETTINGS:

Position-1 OFF Position-2 ON Position-5 OFF Position -6 OFF Position -7 OFF

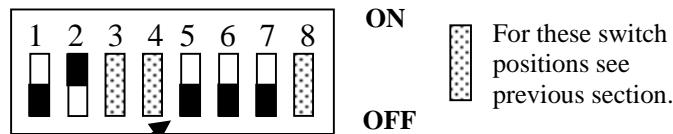

Indicates Switch in OFF Position.

*NOTE: Hoist, Trolley and Bridge are listed here as traditional configurations, the installer may choose to define the motors differently.

Section 6 - Wiring (Continued)

TABLE 2(I) TR12 2-SPEED WIRING DIAGRAM.
STANDARD 2-SPEED 3, 4 & 5 MOTOR SYSTEM using SELECT

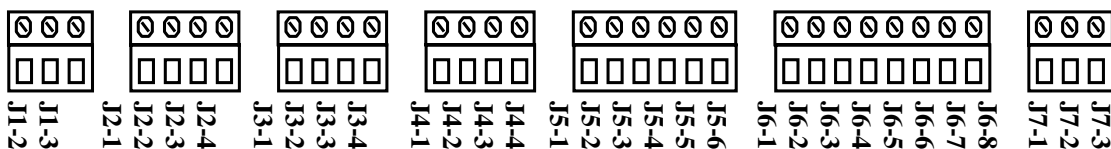
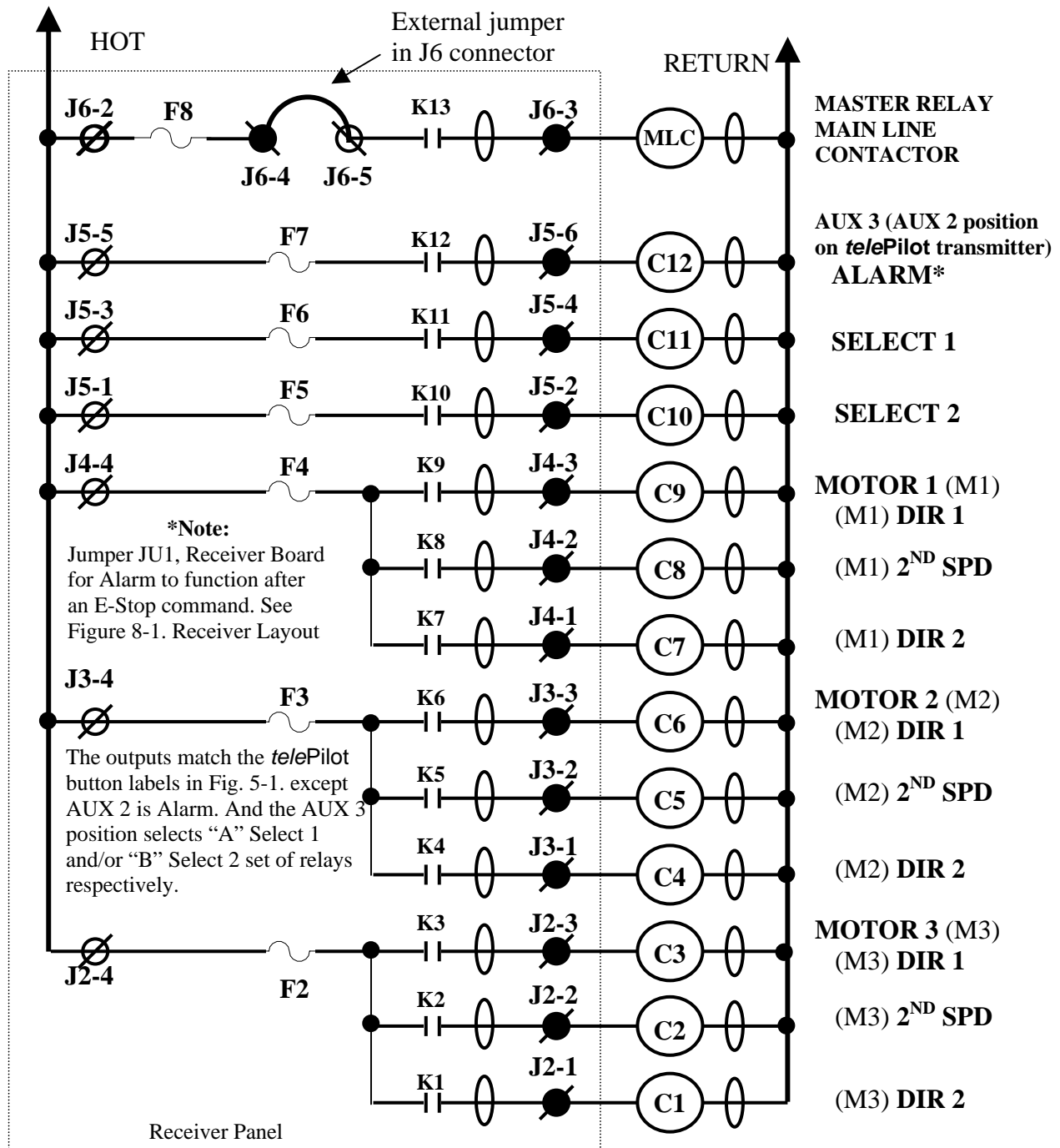

Section 6 - Wiring (Continued)

**TABLE 2(I) TR12 2-SPEED PROGRAMMING DIAGRAM.
STANDARD 2-SPEED 3, 4 & 5 MOTOR SYSTEM using SELECT**

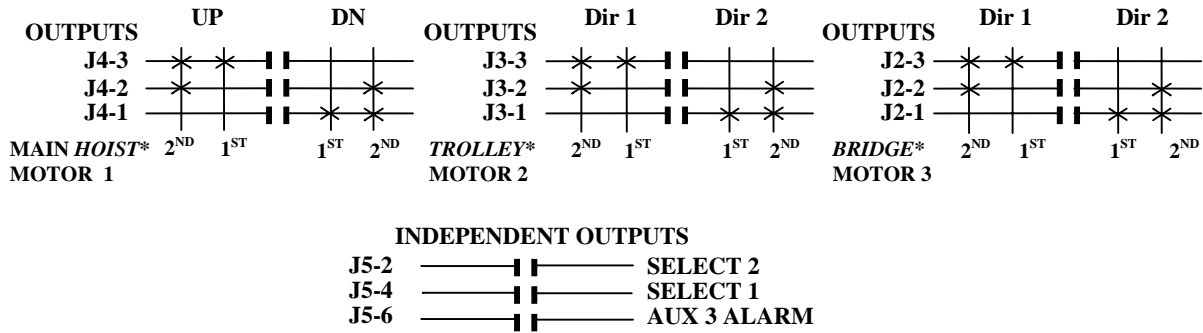

MOTOR 1 CONNECTIONS

- J4-3 MAIN HOIST UP
- J4-2 MAIN HOIST 2ND SPEED
- J4-1 MAIN HOIST DOWN
- J4-4 HOT (J4-1, 2 & 3)

MOTOR 2 CONNECTIONS

- J3-3 TROLLEY DIR 1
- J3-2 TROLLEY 2ND SPEED
- J3-1 TROLLEY DIR 2
- J3-4 HOT (J3-1, 2 & 3)

MOTOR 3 CONNECTIONS

- J2-3 BRIDGE DIR 1
- J2-2 BRIDGE 2ND SPEED
- J2-1 BRIDGE DIR 2
- J2-4 HOT (J2-1, 2 & 3)

INDEPENDENT CONNECTIONS

- | | |
|------------------|----------------------|
| J5-2 SELECT 2 | J5-1 HOT SELECT 2 |
| J5-4 SELECT 1 | J5-3 HOT SELECT 1 |
| J5-6 AUX 3 ALARM | J5-5 HOT AUX 3 ALARM |

TRANSMITTER SWITCH SETTINGS (This configuration does not apply to the Membrane transmitter).

telePilot USE PDA SCREEN (Program the configuration switches 5, 6 and 7 to OFF. Under “Main/Aux” select the word “Select”).

PENDANT, JLTx AND SLTx TRANSMITTER SWITCH SW4 “D” SETTINGS:

- | | | | | |
|------------|------------|------------|-------------|-------------|
| Position-1 | Position-2 | Position-5 | Position -6 | Position -7 |
| ON | ON | OFF | OFF | OFF |

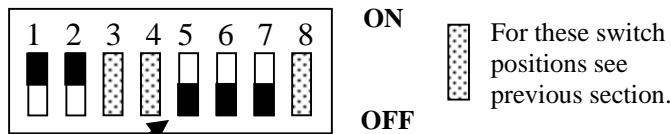

Indicates Switch in OFF Position.

*NOTE: Hoist, Trolley and Bridge are listed here as traditional configurations, the installer may choose to define the motors differently.

Additional programming available:

The select function can be inverted by turning switch position 4 to ON (the Configuration Switch on the telePilot or SW4 “D” for the Pendant, JLTx and SLTx).

Tandem select operation, both select 1 and 2 on at the same time, can be disabled by un-checking the box marked “Tandem” on the telePilot or turning on the Configuration Switch SW 4 “D” for the Pendant, JLTx and SLTx.

Section 7 – Programming

7-1. Access Code Programming.

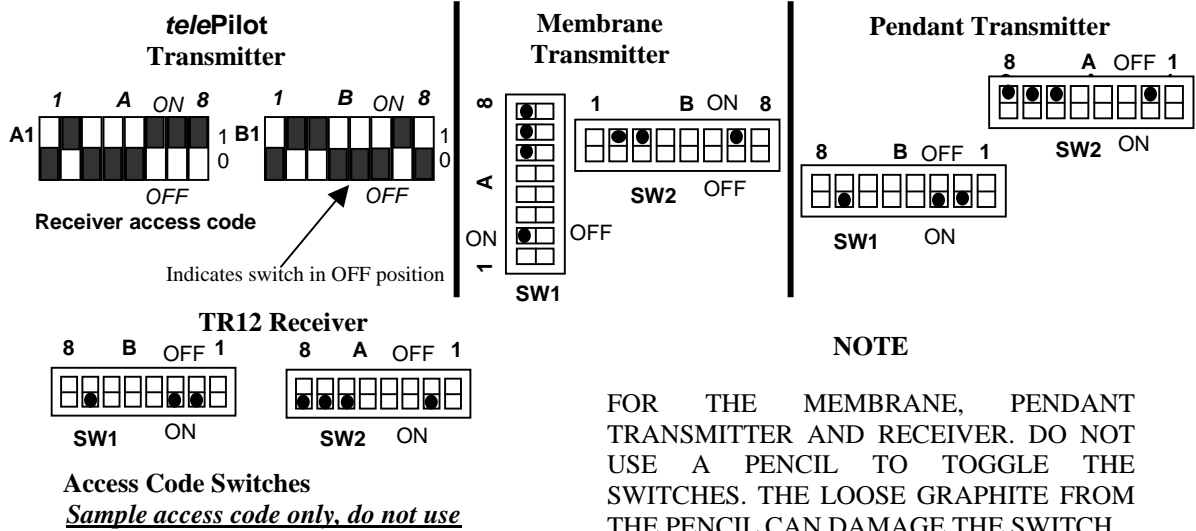

MODEL # -10XXXXXXXXX
 S/N=XXXXXXXXXXXXXXXXXX
 ACCESS CODE SETTING
1 A 8 1 B 8
 0 1 0 0 1 1 1 0 1 1 0 0 0 1 0
 FREQ : = AK01 J# = XXXXX



WARNING

TWO OPERATIONAL TRANSMITTERS WITH THE SAME ACCESS CODES OPERATING AT THE SAME TIME IS A DEFINITE SAFETY HAZARD. FAILURE TO FOLLOW THIS WARNING COULD RESULT IN SERIOUS INJURY OR DEATH AND DAMAGE TO EQUIPMENT.

Sample Membrane or Pendant Transmitter Access Code Label
Sample access code only do not use

Figure 7-1. Access Code Setting.
 (A dot on a switch position or a "1" in the label is an indication that the respective switch position should be ON).

7-1.1. Programming Access Codes.

The access code is set at the factory and should not be changed unless absolutely necessary. If you are reprogramming a spare or new transmitter make sure the other transmitter is securely taken out of service.

Also a label on the transmitter lists the access code settings inside. The positions on the transmitter label match the switch settings. The "1" by A1 means the switch position A1 should be "ON" and "0" means A1 should be "OFF".

7-1.2. Changing Transmitter Access Codes.

7-1.2.1. telePilot Access Code Programming.

For detailed instructions on setting parameters including access codes see Section 7-8. telePilot Programming.

7-1.2.2. Membrane Transmitter Access Code Setting.

Open the back battery door and take out the batteries as a safety precaution.

Remove the 6 screws on the front cover. Lift out switch-pad, logic board and turn logic board over.

Locate the dip switches marked "A" and "B". See Figure 8-3. Membrane Transmitter M/C Module E10635. With a pen or pointed object toggle the switches to match the Access Code on

Section 7 – Programming (Continued)

the receiver. A dot on the switch diagram means that switch position is ON. For Membrane transmitters the access code positions A1-A4 can be accessed through the battery compartment.

Reassemble unit; replace the batteries and test.

7-1.2.3. Pendant Transmitter Access Code Setting.

Open the back battery door and take out the batteries as a safety precaution.

Remove the 8 screws on the front cover. Turn transmitter over and remove back cover.

Locate the dip switches marked “A” and “B”. See Figure 8-6. Pendant Transmitter M/C Module E10636. With a pen or pointed object toggle the switches to match the Pendant Transmitter Code Diagram on the door of the receiver. A dot on the switch diagram means that switch position is ON.

Reassemble unit; replace the batteries and test.



WARNING

AFTER CHANGING THE ACCESS CODES ON THE TRANSMITTER, TEST THE UNIT BY TURNING IT ON AND OFF NEAR THE APPROPRIATE RECEIVER. IF THE RECEIVER DOES NOT RESPOND, DO NOT ACTIVATE A FUNCTION BUTTON! THE TRANSMITTER MAY HAVE THE WRONG ACCESS CODE, WHICH COULD MOVE ANOTHER CRANE. RE-CHECK THE ACCESS CODE IN THE TRANSMITTER AND RETEST. FAILURE TO FOLLOW THIS WARNING COULD RESULT IN SERIOUS INJURY OR DEATH AND DAMAGE TO EQUIPMENT.

7-1.3. Receiver Access Code Setting.

The access code is preset at the factory and should not be changed unless absolutely necessary. The access code switches are labeled “B” and “A”. See Figure 8-1. Receiver Layout for switch location.

The programming in the receiver(s) must match the transmitter. If looking at the label on the

outside of the transmitter, take note that positions “A” and “B” number from the left 1 through 8.

NOTE

IN EVENT PROGRAMMING OF ACCESS CODES IS REQUIRED, TAKE SPECIAL CARE TO CORRECTLY LOCATE ACCESS CODE SWITCHES A AND B. LOOK FOR THE LABELS A AND B ON THE PRINTED CIRCUIT BOARD NEAR THE RESPECTIVE SWITCHES. DETERMINE THEIR ORIENTATION. THE SWITCHES MAY NUMBER FROM LEFT TO RIGHT OR RIGHT TO LEFT. LOOK FOR THE NUMBERING ON THE SWITCHES. MATCH ACCESS CODES A1, A2, -- B1, B2 ETC.

After changing the access code, test the receiver (s) with a matching transmitter. (If the red LED DS9 comes ON in either receiver the code does not match, recheck the access code settings.



WARNING

THE ACCESS CODES IN THE RECEIVER ARE UNIQUE AND FACTORY PRESET. DO NOT CHANGE THESE ACCESS CODES UNLESS YOU ARE REPLACING AN EXISTING RECEIVER AND ITS ACCESS CODE. CHANGING THIS CODE COULD MAKE IT COMMON WITH ANOTHER RECEIVER ACCESS CODE, WHICH COULD MOVE ANOTHER CRANE. NO TWO SYSTEMS IN ANY LOCATION SHOULD EVER HAVE THE SAME ACCESS CODES INDEPENDENT OF FREQUENCY. FAILURE TO FOLLOW THIS WARNING COULD RESULT IN SERIOUS INJURY OR DEATH AND DAMAGE TO EQUIPMENT.

Section 7 – Programming (Continued)

7-2. Receiver Frequency Programming.

The TR12 receiver is equipped with a frequency synthesizer that allows frequencies to be easily changed without retuning. Normally the frequency does not have to be changed; the unit comes programmed to a specific frequency listed on the Frequency and Access Code Label on the TR12 receiver door.

7-2.1. RF Receiver Board Frequency Synthesizer.

Located in the TR12 receiver is the RF Receiver Board. The circuitry on this board contains a digital oscillator and synthesizer that are controlled by a microprocessor. This eliminates the need for specific crystals to change frequencies. A pair of programming pins allows the unit to be reprogrammed in the field to a different channel. The on board microprocessor automatically retunes the RF receiver when the channel is changed; no retuning or any other adjustment is required.

7-2.2. Reading The Channel (Frequency).

Using Figure 8-1. Receiver Layout. locate the RF Receiver Board. Locate the Top Viewing Window (see Figure 7-2. RF Receiver Board). Looking in the Top Viewing Window close to the edge of the board is a red LED that, with the power to the receiver ON, is constantly lit. This indicates the RF Receiver Board is ON and working. Looking farther back into the Top Viewing window there are two flashing LEDs, a red one and a green one. These LEDs flash repeatedly and slowly so allow some time to see them flash. These flashing LEDs indicate the channel (frequency) the unit is receiving.

The counting is done in two digits, where the two digits indicate channel number. The red LED counts (flashes) the channel number in two digits; the green LED indicates (flashes) the spacing and position of the counted digit. The ones digit is counted first and then the tens digit with one green LED flash indicating the beginning of the count of ones digit and two green LED flashes indicating the beginning of the tens digit count.

An example is if the channel is AK04 the channel number is 04. The ones digit is 4 (four red flashes) and the second is zero (no red flash).

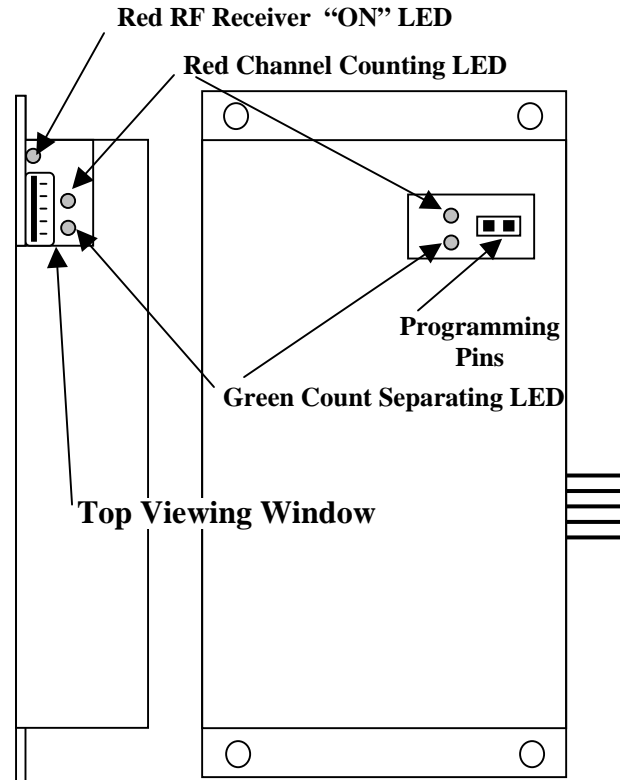

RF Receiver Board Top View **RF Receiver Board Side View**

Figure 7-2. RF Receiver Board.

The repeated sequence for reading channel 4 is:
Long pause, green, red, red, red, red, short pause
green, green, (no red flash, zero).

The repeated sequence for reading channel 12 is:
Long pause, green, red, red, short pause, green,
green, red.

Other examples are (equals count):

- AK01 (1): green, red, short pause, green, green.
- AK02 (2): green, red, red, short pause, green, green.
- AK05 (5): green, red, red, red, red, red, short pause, green, green.
- AK07 (7): green, red, red, red, red, red, red, red, short pause, green, green.
- AK10 (10): green, short pause, green, green, red.
- AK11 (11): green, red, short pause, green, green, red.
- AK14 (14): green, red, red, red, red, short pause, green, green, red.
- AK20 (20): green, green, green, red, red.
- AKA06 (27): green, red, red, red, red, red, red, red, short pause, green, green, red, red.

Section 7 – Programming (Continued)

7-2.3. Reprogramming The Synthesizer

The RF Receiver can be reprogrammed in the unit without removing the RF Receiver Board. Locate the Programming Pins by looking at the side of the RF Receiver Board (see Figure 7-2. RF Receiver Board). To reprogram the synthesizer a small metal tipped blade screwdriver or other tool is necessary to short the two pins together to put in the reprogramming mode.

Having located the programming pins and while watching the flashing red Channel Counting LED, short the programming pins together and keep them shorted. (Do not be concerned while shorting these pins together about touching the metal RF Receiver shield with the shorting tool, it will not cause any damage to the circuitry).

When the Programming Pins are shorted the RF Receiver will go into the programming mode. **KEEP THE PINS SHORTED UNTIL THE PROGRAMMING IS COMPLETE.** The green and red channel indicating LEDs will complete one last channel indication and then only the red LED Channel Counting LED will start to flash. The synthesizer will start programming from channel AK01 and count up in sequence for each channel with a pause in between each channel count. A full count of flashes will be made for each channel with a short pause in between each channel counts by the red Channel Counting LED. The channel counts will increase by one channel after each pause. Keep track of the individual channel counts to determine which frequency the synthesizer is on.

The flashing sequence is as follows: one flash (AK01) short pause, two flashes (AK02), short pause, three flashes (AK03), etc. For channel numbers ten and greater the red LED will still count these out completely, so for channel AK12 there will be twelve flashes. The green LED DOES NOT flash during channel programming.

When you have reached the correct count for the channel desired, remove the short from the shorting pins immediately. Wait a minute for the RF Receiver to automatically retune itself and the green and red channel indicating light should then start to flash indicating the current channel number.

Check the channel count to verify that the RF Receiver is programmed to the desired channel.

(If you have passed the channel number desired wait a minute for the green LED to flash and re-short the pins, the count will begin again from channel AK01).

Channel and Frequency Designations by Count.

Indicator Count	Channel Designator	Actual Frequency
1.	AK01	439.8 MHz
2.	AK02	439.6 MHz
3.	AK03	439.4 MHz
4.	AK04	439.2 MHz
5.	AK05	439.0 MHz
6.	AK06	438.8 MHz
7.	AK07	438.6 MHz
8.	AK08	438.4 MHz
9.	AK09	438.2 MHz
10.	AK10	438.0 MHz
11.	AK11	437.8 MHz
12.	AK12	437.6 MHz
13.	AK13	437.4 MHz
14.	AK14	437.2 MHz
15.	AK15	437.0 MHz
16.	AK16	436.8 MHz
17.	AK17	436.6 MHz
18.	AK18	436.4 MHz
19.	AK19	436.2 MHz
20.	AK20	436.0 MHz
21.	AKA00	433.125 MHz
22.	AKA01	433.325 MHz
23.	AKA02	433.525 MHz
24.	AKA03	433.725 MHz
25.	AKA04	433.925 MHz
26.	AKA05	434.125 MHz
27.	AKA06	434.325 MHz
28.	AKA07	434.525 MHz
29.	AKA08	434.725 MHz

Section 7 – Programming (Continued)

7-3. Multibox.

7-3.1. Multibox Operation.



WARNING

IF YOUR UNIT WAS NOT ORDERED WITH MULTIBOX DO NOT ATTEMPT TO PROGRAM MULTIBOX IN THE FIELD. TELEMOTIVE MUST COORDINATE ACCESS CODE ASSIGNMENTS WITH THE TRANSMITTERS PRIOR TO ENABLING MULTIBOX. PLEASE CONTACT TELEMOTIVE IF YOU NEED TO ADD MULTIBOX. FAILURE TO FOLLOW THIS WARNING COULD RESULT IN SERIOUS INJURY OR DEATH AND DAMAGE TO EQUIPMENT.



WARNING

IF YOUR UNIT HAS MULTIBOX DO NOT ATTEMPT TO PROGRAM ADDITIONAL TRANSMITTERS IN THE FIELD. TELEMOTIVE MUST COORDINATE ACCESS CODE ASSIGNMENTS WITH THE NEW TRANSMITTERS PRIOR TO EXPANDING MULTIBOX. PLEASE CONTACT TELEMOTIVE IF YOU NEED TO ADD ADDITIONAL TRANSMITTERS. FAILURE TO FOLLOW THIS WARNING COULD RESULT IN SERIOUS INJURY OR DEATH AND DAMAGE TO EQUIPMENT.

The TR12 has Multibox capability that allows up to 8 transmitters to access a single system. Only one transmitter may control the receiver(s) at a given time. Access is on a first come first serve basis. Once a transmitter has gained control, another transmitter may not access the receiver(s) until the controlling transmitter relinquishes control by transmitting an OFF command to the receiver(s) or the receiver(s) times out due to inactivity.

The first transmitter to send an ON command after the receiver has been released will then gain control of the receiver(s). The number of transmitters (1-8) allowed to control the

receiver(s) is dip switch selectable on the Receiver Board.

NOTE

THE DESIRED MULTIBOX TRANSMITTERS MUST HAVE CONSECUTIVE ACCESS CODES BEGINNING FROM THE FIRST ACCESS CODE.

7-3.2. SW3 Switch Multibox Settings.

Dip switch settings on the Receiver Board control the number of transmitters. This is done by the Receiver Configuration Switch SW3 (dip switch positions -1, -2 and -3). Different settings are used for 2, 3, 4 and up to 8 transmitters. See Table 7-1. Multibox Switch Settings for proper Multibox settings.

The Receiver Configuration Switch, dip switch SW3, is found on the Receiver Board. See Figure 8-1. Receiver Layout.

On the transmitters sequential access codes are required. These are set on access code switch “A” positions “1”, “2” and “3” or more as required. The first transmitter uses the same access code as the receiver. The other transmitters have the there access code sequentially incremented each by one extra bit. With “A1” being the least significant bit. See Figure 7-1. Access Code Settings.

For Membrane transmitters the Access code positions A1-A2 can be accessed through the battery compartment. The Pendant Transmitter requires the back to be removed.

See Table 7-1. Multibox Switch Settings below for appropriate settings for both the transmitters and receiver(s).

Section 7 – Programming (Continued)

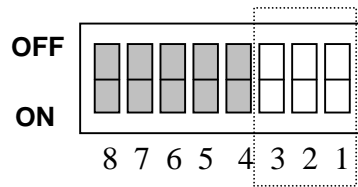

Figure 7-3. SW3 Receiver Multibox Dip Switches

Table 7-1. Multibox Switch Settings.

Receiver (See Figure 8-1). SW3 Switch Settings			Maximum Transmitters	Transmitter (Membrane and Pendant only). Access Code Switch Settings
3-1	3-2	3-3		
OFF	OFF	OFF	1	First Access Code
ON	OFF	OFF	2	First Access Code + 1 bit
OFF	ON	OFF	3	First Access Code + 2 bits
ON	ON	OFF	4	First Access Code + 3 bits
OFF	OFF	ON	5	First Access Code + 4 bits
ON	OFF	ON	6	First Access Code + 5 bits
OFF	ON	ON	7	First Access Code + 6 bits
ON	ON	ON	8	First Access Code + 7 bits

Section 7 – Programming (Continued)

7-4. Custom Programming.

7-4.1. Receiver Programming Options.

The following parameters are programmable in the receiver: (See below for details).

- Auto Alarm – Sounds alarm on turn on.
- E-STOP Alarm – Sends Alarm on E-STOP.
- Single or 2-speed system – Assigns outputs.
- Latching of auxiliary relays – Up to two relays.
- Time-out-timer disable.
- Number of Multibox transmitters.

7-4.2. Transmitter Programming Options.

The following parameters are programmable in most transmitters: (See Sections 7-6., 7-7. and 7-8. Membrane, Pendant and *telePilot* Programming for details).

- Switch Position – Hoist, Trolley Etc.
- Timer-out-timer operation.
- Modes – Single speed switch grouping.
- Crane configuration -
- Tandem disable – Eliminates “both”
- Select invert – Inverts the select function.

7-5. Receiver Programming. (For the location of specific programming switches see Figure 8-1. Receiver Layout).

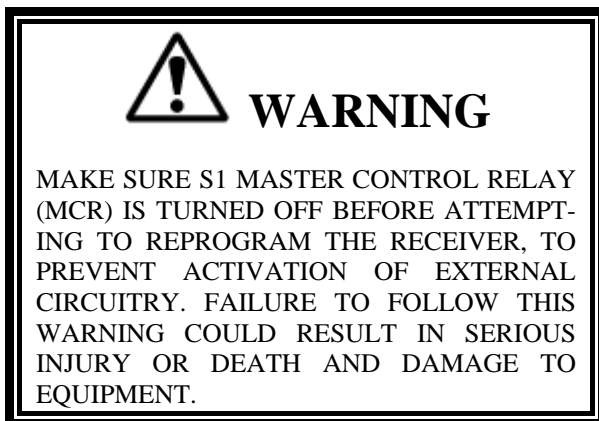

7-5.1. Auto Alarm And E-STOP Alarm.

The receiver can have either one of these functions or both. The use of either one of these two functions dedicates one specific control relay to operate an external alarm. An external alarm (not supplied) needs to be connected to this relay.

7-5.2. Auto Alarm (SW4-8). Normally OFF.

Gives about 5 seconds of alarm when the transmitter is first turned on.

To Enable.

Connect an external alarm. Move dip switch SW4-8 on the Receiver Board to the ON position. See Section 6. Wiring for the location for the location of the alarm relay.

7-5.3. E-STOP Stop Alarm (SW4-7). Normally OFF.

Gives about 5 seconds of alarm when the Emergency Stop (E-STOP) is activated on the transmitter.

To Enable.

Connect an external alarm. Move dip switch SW4-7 on the Receiver Board to the ON position and jumper JU1 to ON. See Figure 8-1. Receiver Board Layout for the position of JU1. Jumper JU1 facilitates bypassing the E-STOP shutdown to the Alarm Relay so it can be activated during an E-STOP shutdown See Section 6. Wiring. for the location for the location of the alarm relay.

7-5.4. 2-Speed Or Single-Speed Outputs (SW3-5). Normally OFF for 2-Speed.

Turning ON switch SW3-5 changes the relay output pattern to best match the needs of a single-speed system. See Section 6. Wiring for appropriate output pattern.

7-5.5. Auxiliary Functions General.

The TR12 receiver has up to 3 auxiliary (Aux) function capability. These Aux functions are dedicated relays that can be used to sound horns, light lights or other functions. Typically a TR12 has 3 Aux functions (for standard 2-speed). See Section 6. Wiring for the location for the location of the auxiliary relays. However, there are a number of specialties and variations available. If your transmitter does not have a document describing these functions, the easiest way to determine what the Aux functions do is to look at the relay outputs and while depressing the appropriate Aux switch on the transmitter see which LED lights for which relay.

7-5.5.1. Auxiliary Function Relay Latching (SW4-2 and -3). Normally All OFF.

Section 7 – Programming (Continued)

Enables the appropriate auxiliary function relay to operate in a latched mode, on or off, rather than as a momentary contact. Which function is latchable and which relay is latched depends on the particular transmitter used.

Switch S4, positions 2 and 3 on the Receiver Board each enable a separate relay to be latched when turned on. See Section 6. Wiring for the specific details on latchable auxiliary relays

7-5.6. Time Out Timer Enable (SW3-8). Normally OFF.

The receiver contains a time out timer. If a receiver once turned on by a transmitter does not receive a signal from a transmitter for a period of 15 minutes the receiver shuts down. Setting S3-8 to ON disables this function.

7-5.7. Multibox (SW3-1, -2, and -3). Normally All OFF.

See Section 7-3. Multibox. One transmitter can only control the TR12 receiver with a specific access code at a time. However, Multibox capability allows the TR12 receiver to automatically switch to a new transmitter when the current controlling transmitter has been turned off and a new transmitter turned on. Up to 8 different transmitters can control one receiver. To enable this function the receiver must be preprogrammed from the factory for Multibox and the correct access codes must be programmed into the appropriate transmitters. (Note: access codes are factory programmed into the receiver and the access codes are sequential.)

7-6. Membrane Transmitter Programming.

The Single-Speed or the 2-Speed 10K12 Membrane Transmitter may be used with the TR12 Receiver. The Membrane Transmitter M/C Board is shown in Figure 8-6. Refer to paragraphs below for programming details.

7-6.1. Membrane Transmitter Switch Settings.

SW3

Position Controls

- 1-3 Switch positioning. (2-Speed only).
- 4 ON disables Transmitter Time-out-timer
- 5-7 Special Crane Control Configurations. (2-Speed only).
- 8 No function. Should be set to OFF.

SW4

Position Controls

- 1-2 Mode Select. (Single-Speed only).

7-6.2. SW3 Positions 1-3 Switch Positioning, 2-Speed Membrane Only. (Standard configuration all “OFF”).

If replacing a Pendant Transmitter with a Membrane Transmitter on an existing installation or making them interchangeable and keeping the existing receiver wiring, open the Membrane Transmitter, find dip switch SW3 and move position 1 (SW3) to “ON”. See Figure 8-3. Membrane Transmitter M/C Module E10635. The Membrane Transmitters labeling and functions North and South, East and West will match the Pendant Transmitter.

7-6.3. SW3 Position 4 Time-out-timer Disable. (Normally keep turned “OFF”).

The transmitter has an approximate 15-minute time-out-timer. If the transmitter is not used for over 15 minutes it will shut down. This transmitter time-out-timer function is transmitter dip switch selectable. SW3 position 4 disables the time-out-timer. Turning SW3-8 “ON” disables the time-out-timer. If disabling the transmitter time-out-timer, remember to also replace the receiver(s) EPROM(s) to disable the time-out-timer in the receiver.

7-6.4. Positions 5-7 Special Crane Control Configurations, 2-Speed Membrane Only. (Standard all “OFF”).

The 10K12 2-Speed Membrane transmitter is available with special crane control configurations. These options are switch configurable on the transmitter. Section 6. Wiring shows all the different crane configurations and the switch positioning needed to achieve them. The standard transmitter comes with the output standard output configuration. **For 2-speed special crane control configurations:** See Section 6. Wiring and program SW3 respectively on the transmitter.

7-6.5. Position 8 No function. (Keep turned “OFF”).

7-6.6. Transmitter Programming SW4 Positions 1-2 Mode Enable. (All 2-speed configurations all “OFF”).

Section 7 – Programming (Continued)

Mode 0, SW4 1 turned “OFF” and SW4 2 turned “OFF”. From the factory the standard 2-Speed Membrane Transmitter is configured this way. This mode in the Membrane Transmitter is for all 2-speed applications. If the Membrane Transmitter has a 2-speed keypad SW4 must be set to all “OFF” positions.

7-6.7. Single-Speed Modes 1-3. (The following three different single-speed modes are listed for single-speed Membrane Transmitters only). See Section 7-6.9 for details.

Mode 1, SW4 1 turned “ON” and SW4 2 turned “OFF”. This configuration gives four-motor single-speed with up to four auxiliaries. This configuration uses the single-speed keypad with two auxiliaries labeled P1 and P2.

Mode 2, SW4 1 turned “OFF” and SW4 2 turned “ON”. This configuration gives four-motor single-speed with four auxiliaries. This configuration uses the single-speed keypad with four auxiliaries labeled Aux 1 through Aux 4.

Mode 3, SW4 1 turned “ON” and SW4 2 turned “ON”. Allows for 12 independent ON/OFF functions (relays) per transmitter button pushed.

Section 7 – Programming (Continued)

7-6.8. Repositioning Of Membrane Transmitter Motion Switch Functions (for 2-Speed Membrane Transmitter only).

SW3 positions 1 through 3 can change the functional positions of the switches controlling bridge, hoist and trolley. This can be useful to align East/West and North/South. This reconfiguration does NOT affect receiver wiring. See Figure 8-3. Membrane Transmitter M/C Module E10635 for switch location.



WARNING

CHANGING THESE SWITCHES CHANGES THE FUNCTIONAL OPERATION OF THE CRANE IN RELATIONSHIP TO THE TRANSMITTER BUTTON BEING DEPRESS-ED. THE FUNCTIONAL OPERATION OF THE CRANE SHOULD NEVER BE CHANGED WITHOUT ALL PERSONNEL RESPONSIBLE FOR CRANE OPERATION BEING NOTIFIED PRIOR TO MODIFICATION. FAILURE TO FOLLOW THIS WARNING COULD RESULT IN SERIOUS INJURY OR DEATH AND DAMAGE TO EQUIPMENT.

Figure 7-4. Membrane Transmitter Motion Switch Positioning.

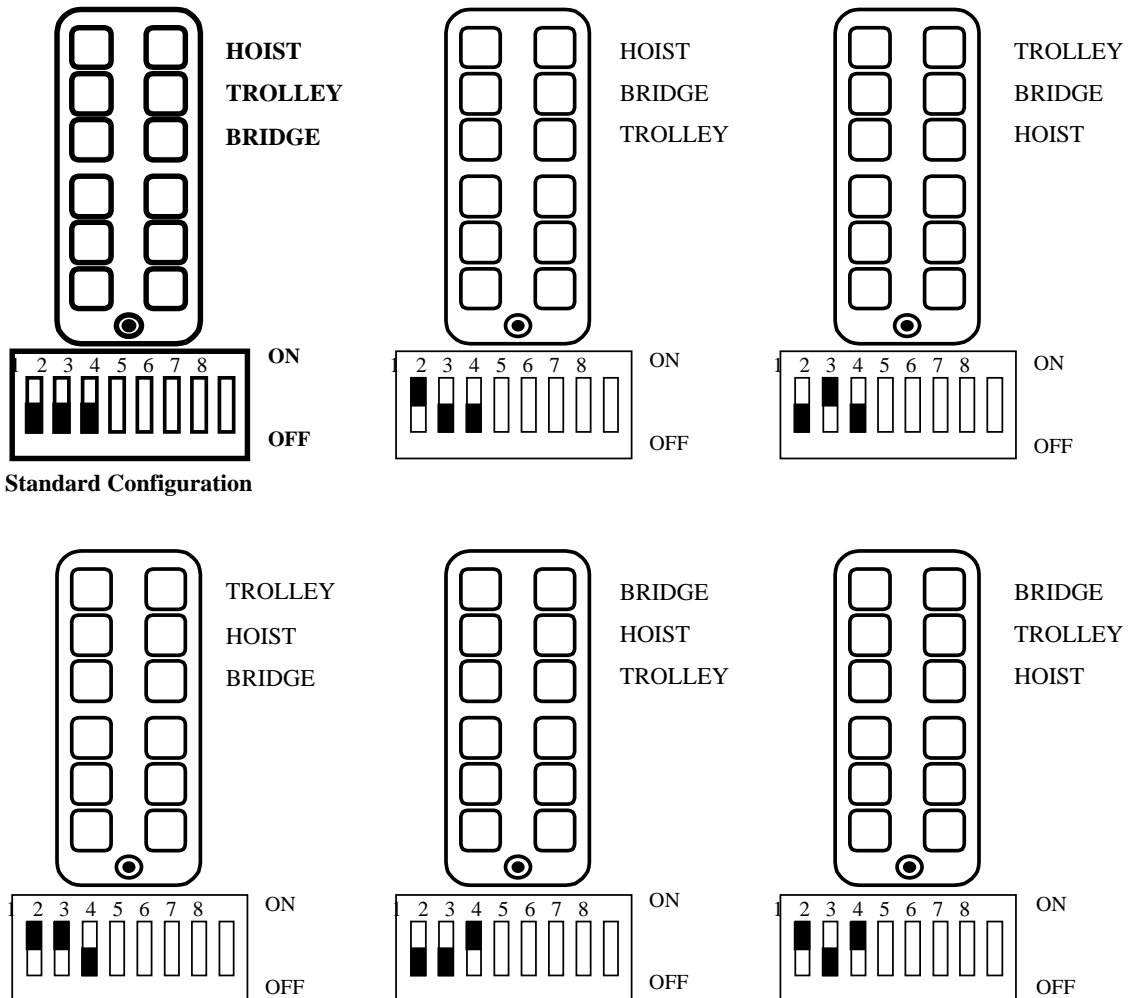

Section 7 – Programming (Continued)

7-6.9. Single-Speed Membrane Transmitter Configurations.

Normally single-speed transmitters are not provided with the 10K6/9. This section is for reference only when using a Single-Speed Membrane Transmitter. All single-speed modes require that the transmitter switch SW3 positions 1 through 3 are all set to OFF.

The EPROM's for the single-speed unit is FW2904-0T and FW2904-0N where 0T means with 15-minute-time-out-timer and 0N means no time-out-timer.

See Figure 8-3. Membrane Transmitter M/C Module E10635 for location of SW3 and SW4. A single-speed keypad (part number S313-1) with special inserts (part number A9657-1) is required for these configurations. The single-speed modes 1 through 3 do not change the outputs, but change the directional lockouts, i.e., E and W cannot be used at the same time. Mode 3 has no lockouts. As for which outputs are controlled by the single-speed transmitter, the switch positions as numbered in the Mode 3 diagram below are indicated on each of the wiring diagrams in Section 6. Wiring.

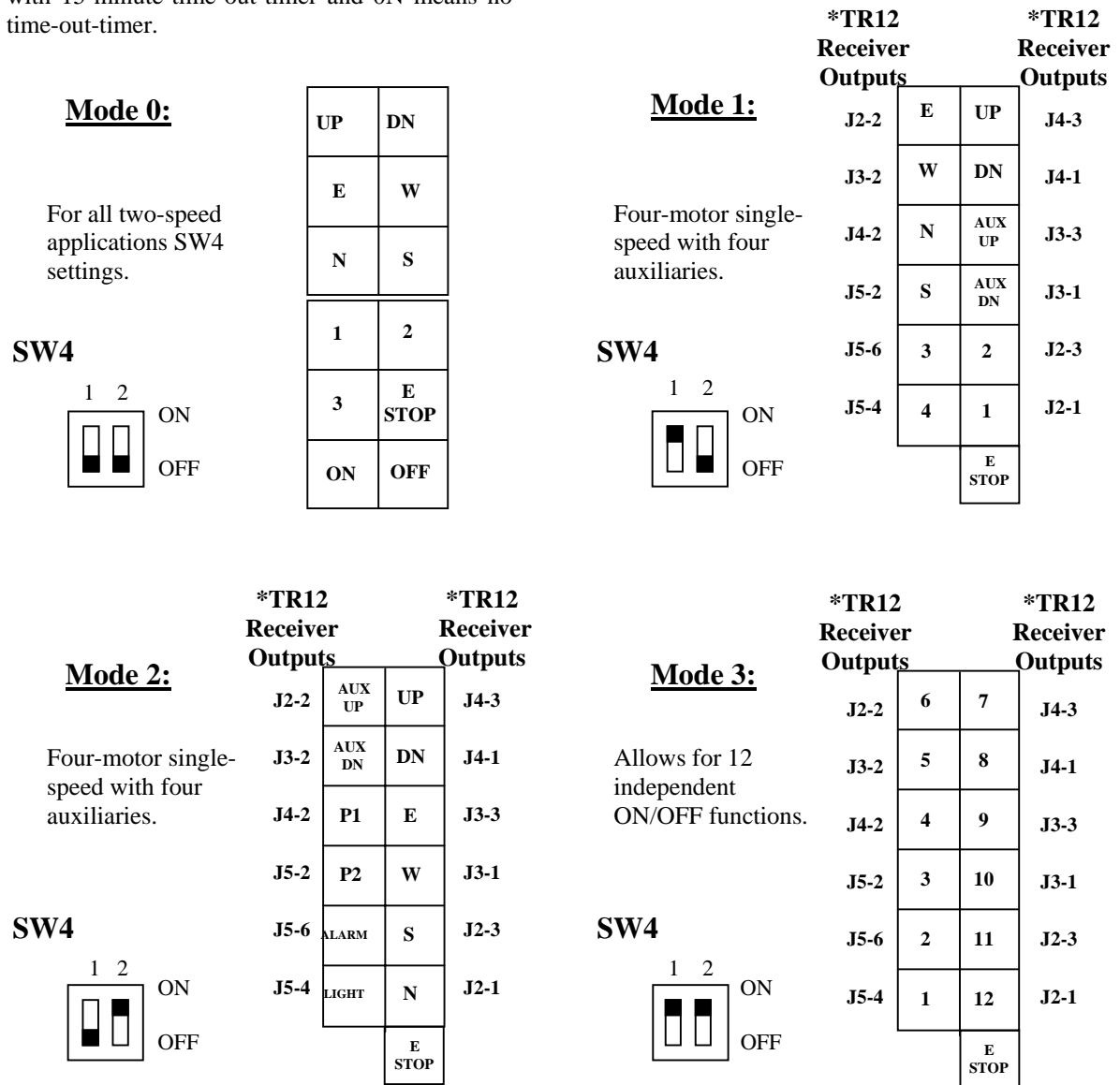

*Single-Speed TR12 Receiver Configuration Only.

Figure 7-5. Membrane Transmitter Single-Speed Configurations.

Section 7 – Programming (Continued)

7-7. Pendant Transmitter Programming.

The Single-Speed or the 2-Speed 10K12 Pendant Transmitter may be used with the TR12 Receiver. The Pendant Transmitter M/C Board is shown in Figure 8-6. Refer to paragraphs below for programming details Procedures.

7-7.1. Pendant Transmitter Switch Settings.

SW3

Position Controls

- 1-3. Switch Positioning. (2-Speed only).
- 4-7. No function, keep off.
8. Time-out-timer disable, turn “ON” to disable time-out-timer.

SW4

Position Controls

- 1-2 Mode Select. (Single-Speed Only).
3. Disable Tandem Hoist. (2-Speed only).
4. Invert Crane Select. (2-Speed only).
- 5-7. Special Crane Configurations. (2-Speed only).
8. No function, keep OFF.

7-7.2. Transmitter Switches SW3 And SW4 Programming. (See Section 8-2. Pendant Transmitter Servicing for physical location of transmitter switches).

7-7.3. Transmitter programming SW3

7-7.4. Positions 1-3 Switch Positioning, 2-Speed Only. (Standard configuration all “OFF”).

The functional positions of the various buttons controlling the hoist trolley and bridge can be moved by transmitter dip switch SW3 also. Positions SW3-1 through SW3-3 control these functions. No change in receiver wiring is needed to use these functions. See Section 7-7.13. for switch versus button configurations.

7-7.5. Position 4-7 No Function. (Keep turned “OFF”).

7-7.6. Position 8 Time-out-timer Disable. (Normally keep turned “OFF”).

The transmitter has an approximate 15-minute time-out-timer. If the transmitter is not used for over 15 minutes it will shut down. This transmitter time-out-timer function is transmitter

dip switch selectable. SW3 position 8 disables the time-out-timer. Turning SW3-8 “ON” disables the time-out-timer.

7-7.7. Transmitter Programming SW4

7-7.8. Position 1-2 Mode Enable. (Standard Mode 1 keep 1-2 turned “OFF”).

Mode 1, SW4 1-2 all “OFF”. The 10K12 single-speed system comes standard configured this way from the factory with three motion controls and six auxiliaries (controlled by the toggle switches). The 10K12 2-speed system comes standard configured this way from the factory with three 2-speed controls and three auxiliaries (controlled by the toggle switches, the rotary is non-functional).

Mode 2, SW4 1 turned “OFF” and SW4 2 turned “ON”. The 10K12 2-speed system configured this way is able to control four 2-speed motion controls and no auxiliaries this give bridge, trolley, main and aux hoist. The rotary selector switch functions are H1 main hoist, H2 aux hoist and B both main and aux hoist (the toggle switches are non-functional).

Mode 3, SW4 1 and 2 turned “ON”. The 10K12 2-speed system will control up to 5 motors using the rotary selector switch. This mode reconfigures two of the 10K12 auxiliary outputs (Aux 1 and Aux 2) to be external motor select functions by the rotary switch. In this mode the auxiliary toggle switch Aux 1 and Aux 2 is disabled. When the rotary switch is in the H1 or H2 position Aux 1 relay or Aux 2 relay will pull in respectively when ever trolley or hoist pushbuttons are pressed. When the rotary switch is in B position both Aux 1 and Aux 2 relays will pull in.

7-7.9. Position 3 Disable Tandem For Hoist And Trolley. (Normally keep turned “OFF”).

For cranes with auxiliary hoists and/or trolleys, turning this switch “ON” disables the transmitter selector switch “B” position (both function) that selects tandem operation of hoist or trolley.

7-7.10. Position 4 Invert Crane Select Aux. Outputs. (Normally keep turned “OFF”).

For cranes that use the select function only, turning this switch “ON” inverts the select

Section 7 – Programming (Continued)

function operation so that the relay closes for the unselected function.

7-7.11. Positions 5-7 Special Crane Control Configurations. (Standard all “OFF”).

The 10K12 2-Speed Pendant and SLTX transmitter is available with special crane control configurations. These options are switch configurable on the transmitter. Section 6. Wiring shows all the different crane configurations and the switch positioning needed to achieve them. The standard transmitter comes with the output standard output configuration **For 2-speed special crane control configurations:** See Section 6. Wiring and program SW4 respectively on the transmitter.

7-7.12. Position 8 No Function. (Keep turned “OFF”).

Section 7 – Programming (Continued)

7-7.13. Repositioning Of Pendant Transmitter Motion Switch Functions (for 2-Speed Pendant Transmitter only).

SW3 positions 1 through 3 can change the functional positions of the switches controlling bridge, hoist and trolley. This reconfiguration does NOT affect receiver wiring.

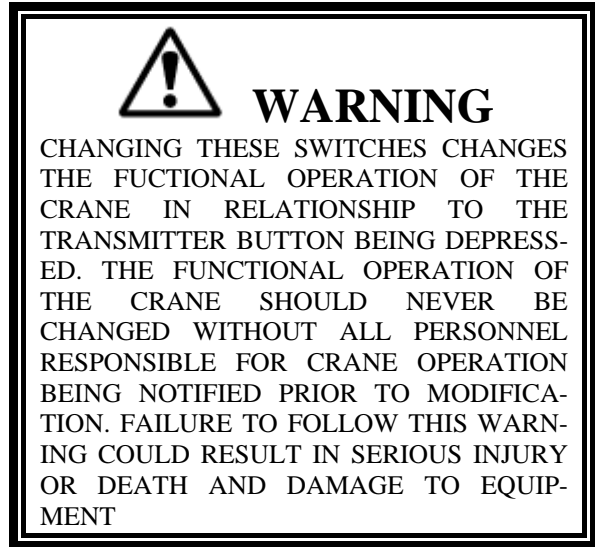
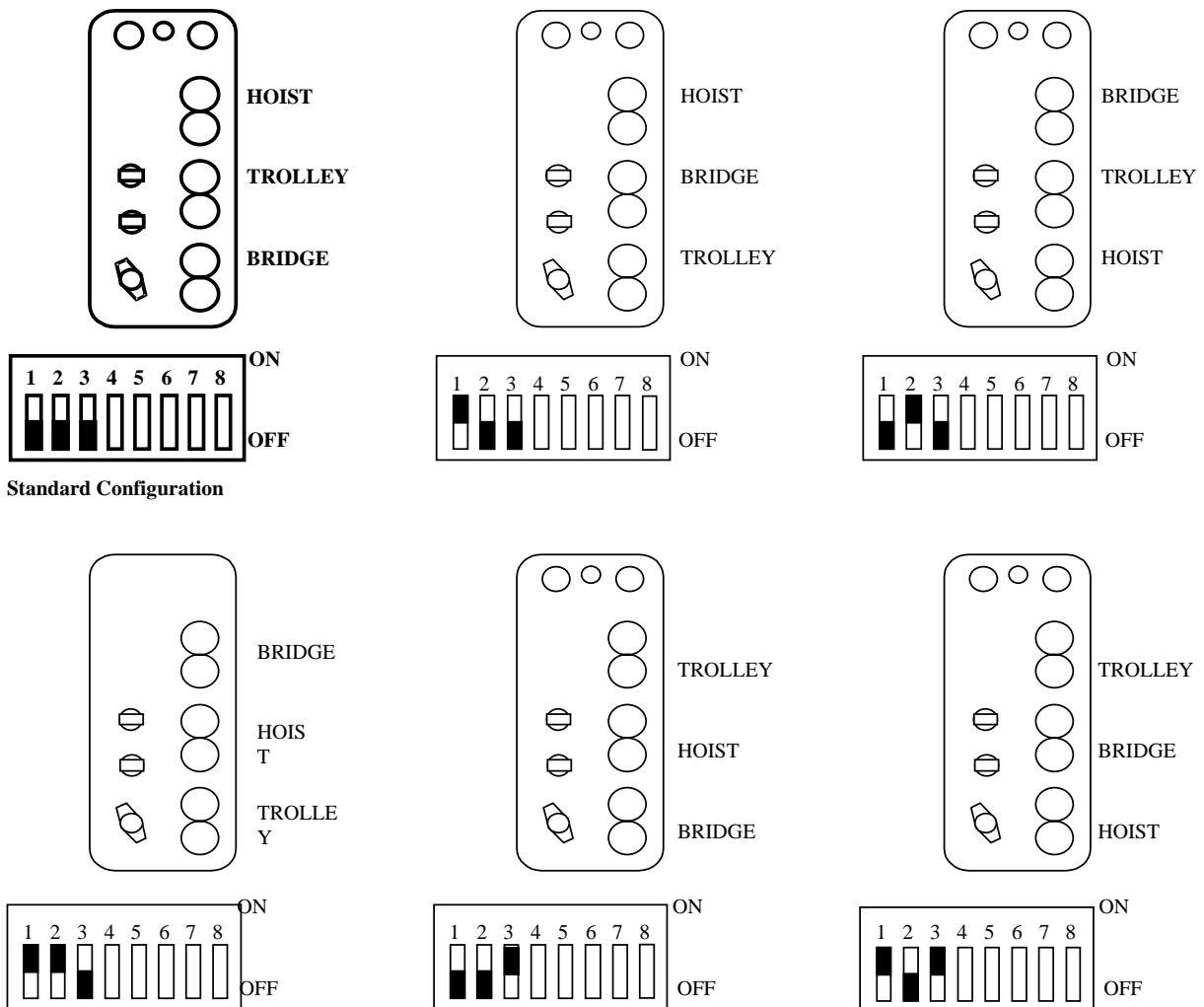

Figure 7-6. Pendant Transmitter Motion Switch Positioning.



Section 7 – Programming (Continued)

7-8. telePilot Programming.

Read Section 5-5. Additional telePilot Operational Features to familiarize you with the features listed below. The telePilot transmitter remote unit for programming uses a PDA (Personal Digital Assistant). Such products as Palm Pilot® or many other products using Palm OS® can be used to run the telePilot programming software. If unsure if your PDA will work or for a recommended product contact the appropriate Telemotive representative or check our website. The software for the PDA is available on a disk shipped with your unit, can be emailed from your Telemotive representative or downloaded from our Website at www.telemotive.com.

telePilot PDA software is quite user friendly and is intended to mimic the dip switch settings used in other Telemotive products without the inconvenience of having to open the transmitter case. The PDA software allows you to select frequency, access code, time-out-timer settings, switch arrangement and crane configuration as in other Telemotive transmitter products.

Load the telePilot programming software into your PDA, refer to your PDA manual or contact Telemotive for the appropriate procedure. Once loaded, look for the Telemotive circle and hook logo labeled telePilot for the appropriate application. Select this application to begin programming.



With the telePilot programmer you can load up to four different transmitter types for use on 10K, 9000 and/or 9100 systems. Each transmitter configuration is stored in a “Bank”. There are up to four banks available. This Bank feature is like having four completely different transmitters in one unit. Up to four Banks (operational configurations) are possible. A Bank is a specific configuration of user-defined parameters including:

- System type
- Frequency
- Access codes
- Also possible:
 - Key arrangement
 - Relay configuration
 - Tandem disable
 - Invert crane select
 - Time-out-timer time
 - Mode selection
 - Alarm settings

After loading the telePilot program the first screen is the initial setup screen.

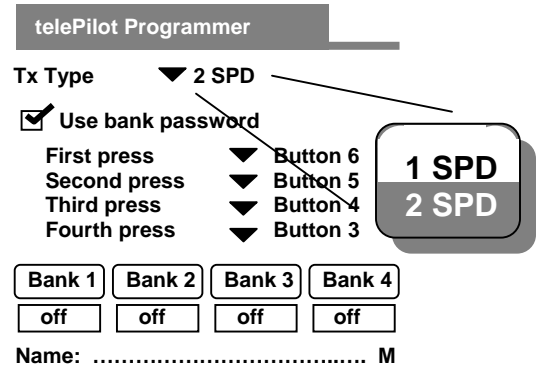

Tx Type (Must be selected).

First select the transmitter type being used (single-speed “1 SPD” or 2-speed “2 SPD”). See Section 5. Operation for differences in the two transmitters. With your PDA stylus tap the arrow after transmitter “Tx Type”. A pull down menu will appear, select “1 SPD” or “2 SPD” and the menu will close showing your selection.

Bank Password (Can be disabled).

Bank password protection is available in changing the transmitter once it has turned OFF. The Bank Password is the same for all Banks. Bank password protection is described in the telePilot operational description in Section 5-5. Additional telePilot Operational Features. **Please familiarize yourself with this section before programming.** A check appears in the box and a list of four buttons. These buttons list the first through fourth buttons and are in the order of entry for the appropriate buttons. Select the four transmitter buttons in the sequence that you wish to be the password by tapping the arrow by “Button #” and making a selection from the pull down menu for each of the four password entries. Be sure to write this password down in a safe place for future reference. The default password is 6, 5, 4, 3.

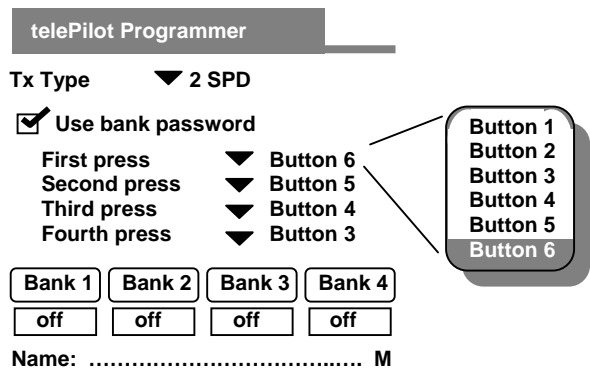

Section 7 - Programming (Continued)

NOTE

ALWAYS REMEMBER TO STORE THE PASSWORD IN A SECURE LOCATION FOR ACCESS IF THE PASSWORD IS LOST OR FORGOTTEN. ONCE THE TRANSMITTER IS PROGRAMMED THERE IS NO WAY TO DEFEAT THE PASSWORD WITHOUT USING A PDA TO EITHER READ THE PASSWORD OUT OR REPROGRAM A NEW ONE.



WARNING

THIS PASSWORD FUNCTION IS NOT TO BE USED AS A SECURITY DEVICE. THE PURPOSE OF THIS FUNCTION IS TO PREVENT ACCIDENTAL BANK SWITCHING. THE BEST FORM OF SECURITY IS ALWAYS TO LOCKUP THE TRANSMITTER WHEN NOT IN SERVICE. FAILURE TO FOLLOW THIS WARNING COULD RESULT IN SERIOUS INJURY OR DEATH AND DAMAGE TO EQUIPMENT.

The Bank password can be disabled during initial programming by the PDA. To disable password protection, tap the check in the box next to the phase "Use bank password". Disabling the Bank password is not recommended unless the operator has access and visibility to all possible cranes controlled.



WARNING

DISABLING THE PASSWORD FUNCTION IS PUTS THE SYSTEM IN ACTIVE BANK SELECT. THIS ALLOWS THE CRANE OPERATOR TO SWITCH BETWEEN BANKS QUICKER. THE OPERATOR IN THIS MODE MUST BE AWARE AND RESPONSIBLE FOR ALL POSSIBLE CONTROLLED CRANES. FAILURE TO FOLLOW THIS WARNING COULD RESULT IN SERIOUS INJURY OR DEATH AND DAMAGE TO EQUIPMENT.

Bank Selection (At least one must be selected).

When done with the password section. Select the number of Bank you wish to program and tap the cell labeled with the appropriate Bank number.

Bank 1	Bank 2	Bank 3	Bank 4
off	off	off	off

The screen should switch to the Setup Bank screen shown below. Complete the Bank setup as described below and hit save. The PDA will revert to the initial screen and the cell for the just programmed Bank should darken and the word "on" appears. Tap on the cell labeled with the next bank you wish to program and a similar "Setup" screen to the one shown below will appear. Continue doing this until you have programmed the four Banks.

You do not have to use all Banks and you do not have to use them in order.

Even after programming a Bank you can turn it back "off". A programmed Bank will not lose its programming by turning it "off". By turning ON and OFF Banks you can easily save certain transmitter configurations in the transmitter to turn them on at a later time with the PDA without having to completely reprogram them.

Bank Programming Setup Screen (Must select system).

Setup Bank #

System ▼ 10K

Freq ▼ AK01

1-SPD

2-SPD

A1	1	0
----	---	---

B1	1	0
----	---	---

10K	9000	9100
10K	9001	9101

Receiver access code
 Multibox
 Auto Turn Off

S3-1	1	0
------	---	---

Timer ▼

Switch conf.: H,T,B

Main/Aux ▼ Aux

The number of the Bank will appear at the top of the screen. **Before selecting any programming feature first go to "System" and select the system type.** Tap on the "System" arrow and select 10K, 9000, 9001, 9100 or 9101 type system. The TR12 Receiver is a 10K type system. If you are unsure of the type of system you have refer to the cover of the systems operating manual for the appropriate system or call your Telemotive representative. After selecting system type, your programming screen will change to match the type of system selected.

Section 7 - Programming (Continued)

The respective screens appear as shown below (the 10K screen is shown first):

system configurations. They are in order of 10K, 9000(1) and 9100(1). Please skip to the appropriate section for your system. Do this in turn for each Bank until all desired Banks are programmed.

Setup Bank #

System ▼ 10K Freq ▼ AK01

A1

1	1	1	1	1	1	1	1	1	1	1	1
0	0	0	0	0	0	0	0	0	0	0	0

Receiver access code

Multibox
 Auto Turn Off

S3-1

1	1	1	1	1	1	1	1	1	1	1	1
0	0	0	0	0	0	0	0	0	0	0	0

Switch conf.: H,T,B

Main/Aux ▼ Aux

Timer ▼

This section appears for 2-Speed only.

Save

Cancel

10K Programming Screen

Setup Bank #

System ▼ 9000(1) Freq ▼ A

A1

1	1	1	1	1	1	1	1	1	1	1	1
0	0	0	0	0	0	0	0	0	0	0	0

Receiver access code

Auto Turn Off

Timer ▼ None

Save

Cancel

9000 and 9001 Programming Screen

Setup Bank #

System ▼ 9100(1) Freq ▼ A

A1

1	1	1	1	1	1	1	1	1	1	1	1
0	0	0	0	0	0	0	0	0	0	0	0

Receiver access code

Auto Turn Off

Timer ▼ None

This appears for 9100(1) Single-Speed only.

Mode ▼ A0

Save

Cancel

9100 and 9101 Programming Screen

The following next three sections of this programming guide are written specifically for each of the three

Section 7 - Programming (Continued)

7-8.1. 10K telePilot Programming.

After you have entered 10K as your system type enter the following items in order for your system:

Frequency (Must be inputted for system to work):

There should be a label either on the receiver or the transmitter listing frequency, it should be a channel number between AK01 to AK20. Find this number and tap the "Freq" arrow and select that channel number.

Screen switch operation.

The screen switches are labeled from left to right "A", "B" and S3. They are numbered from left to right 1 to 8. The darken rectangle to the bottom is "OFF" or "0" the darken rectangle to the top is "ON" or a "1". Tapping the lighten rectangle will cause the switch to toggle.

Access Code (Must be inputted for system to work):

See Section 7.1. Access Code Programming for details on access code programming. There should be a label either on the receiver or the transmitter showing the access code, it should be numbered A1 through A8 and B1 though B8. Find this number and tap the respective switches on the screen. If you cannot find a label with access code information, copy directly from the access code dip switches in your transmitter or receiver, being careful to match the designation and switch position as they do vary from model to model.

Multibox (Optional, skip if you do not wish to use the Multibox feature):

See Section 7-3. Multibox for details on Multibox programming. If your current receiver does not have Multibox do not attempt to use this function. This function WILL NOT turn Multibox on in the receiver. It only assists you in programming the correct transmitter access code for a receiver that already has Multibox. Make sure when you are using the Multibox feature that the access code of the receiver is programmed into the access code above and not one copied from an existing transmitter on a Multibox system. If you cannot find the receiver transmitter code and wish to copy existing transmitter on a Multibox system, put the transmitters access code in the access code switches above and DO NOT check the Multibox box on the PDA.

Select the Tx # this should be the next number in the series of transmitter being put on a Multibox system. If there are two transmitters on already and you are adding a third, select the number 3. Make sure as stated in the Multibox section the receiver is programmed for the appropriate number of transmitters.

The Tx # goes up to 8. Many Multibox systems only go to four. Check with your Telemotive representative if you need more than 4 transmitters on a Multibox system.

10K Single-Speed Programming Screen

10K 2-Speed Programming Screen

Auto Turn Off (Optional, can be skipped):

The telePilot transmitter has a variable length Time-out-timer. To facilitate operation of this timer with various models of receiver the Auto Turn Off feature was created. If this feature is enabled, when the transmitter times out and the transmitter turns OFF, it will before shutting down send an OFF command to the receiver. Check (tap) the box to enable.

Section 7 - Programming (Continued)

10K *telePilot* Programming (Continued).

7-8.1.1. Single-Speed 10K *telePilot* Only:

Skip to next section 7-7.1.2 (below) if 2-speed.

Timer (If unsure of a number start with 15 minutes):

Enables the transmitter time-out-timer. The selections are “None” (meaning the transmitter will never shut off on it own if not used, this is not recommended for battery life) or numbers of minutes till shut down. The minutes are selectable in one-minute steps from 1 to 10 and five minutes steps up to an hour. Tap on the “Timer” arrow; scroll down through the number of minute and tap on the desired number.

Modes 1-3 (The correct mode must be selected for safe operation):

Please refer to **Figure 7-7. Single-Speed 10K *telePilot*** for specific mode details. Modes are various patterns of functional lockouts. If you have UP and a DOWN buttons on a single-speed transmitter controlling a hoist, the transmitter must not be able to send Up and DOWN commands at the same time.

Mode determines the respective buttons that are locked out to each other. Modes do NOT change the configurations of the output relays. Find the desired mode and select its number on the “Mode” selection.

Setup Bank #

System ▼ 10K Freq ▼ AK01

A1 1
0 B1 1
0

Receiver access code

Multibox Tx # ▼ 1

Auto Turn Off

Timer ▼ None
 Mode ▼ 1

10K Single-Speed Programming Screen

This completes the 10K single-speed programming, when completed with the above tap “Save”.

Save will take you back to the initial start screen and turn the Bank ON. At this point select another Bank to program or go to Section 7-9. Loading And Saving The Program.

10K *telePilot* Programming (Continued).

7-8.1.2. 2-Speed 10K *telePilot* Only:

Setup Bank #

System ▼ 10K Freq ▼ AK01

A1 1
0 B1 1
0

Receiver access code

Multibox Tx # ▼ 1

Auto Turn Off

S3-1 1
0 Timer ▼

Switch conf.: H,T,B

Main/Aux ▼ Aux

10K 2-Speed Programming Screen

Programming Switch S3-1

NOTE

IF REPLACING A MEMBRANE OR PENDANT TRANSMITTER, YOU CAN COPY THE SWITCH SETTINGS ON THE EXISTING TRANSMITTER.

Membrane: Copy Switch 3 (all positions) settings on the Membrane transmitter to S3 on the PDA.

Pendant: Copy Switch 3 (positions 1, 2, 3 and 8) settings on the Pendant transmitter to S3 (positions 1, 2, 3 and 8 respectively) on the PDA. Copy Switch 4 (positions 5, 6 and 7) settings on the Pendant transmitter to S3 (positions 5, 6 and 7 respectively) on the PDA. If Switch 4 on the Pendant transmitter has positions 1 and or 2 Switched ON see the write-up on Main/Aux Menu below. If SW4 position 3 is switched “ON” un-check Tandem box on PDA. If SW4 position 4 is switched “ON” check Invert box on PDA.

A detailed table of Transmitter switch programming versus *telePilot* is in Appendix A.

Section 7 - Programming (Continued)

SW3 Positions 1-3 Repositioning of telePilot Transmitter Motion Switch Functions. (Standard configuration all “OFF”).

S3 positions 1 through 3 can change the functional positions of the switches controlling hoist, trolley and bridge. This reconfiguration does NOT affect receiver wiring. As these switches are changed the motor controls are moved.

Standard, Motor 1 is H (Hoist) Motor 2 is T (Trolley) and Motor 3 is B (Bridge). The standard configuration (all switches OFF) is, starting at the top right hand pair of buttons on the transmitter, Motor 1. Moving down to the middle two right hand pair of buttons that is Motor 2. The bottom pair on the right is Motor 3. This is indicated the display “Switch config: H,T,B. The order of Hoist, Trolley and Bridge will vary as S3-1 to 3 switch positions are changed. For an example of switch configurations versus switch settings see Section 7-13. Repositioning of Pendant Transmitter Motion Switch Functions. The settings match the operation of the telePilot.

SW3 Position 4 And 8 Time-out-timer Disable. (Normally turned “OFF”).

Disables the transmitter time-out-timer if turned ON. If the time-out-timer is active, the length of time for time out can be selected for numbers of minutes till shut down. The minutes are selectable in one-minute steps from 1 to 10 and five minutes steps up to an hour. Tap on the “Timer” arrow and scroll down through the number of minutes and tap on the desired number.

Positions 5-7 Special Crane Control Configurations. (Standard all “OFF”).

Section 6. Wiring shows all the different crane configurations and the switch positioning needed to achieve them. The standard transmitter comes with the output standard output configuration. For special crane control configurations program S3 positions 5-7 to match the programming information shown for the respective wiring diagram. When any of the special crane configuration switches is turned ON, the words “Crane control enabled” appears on the display and Main/Aux disappears.

Position 8, Same as Switch Position 4. See write up for switch 4 above (Normally turned “OFF”).

Main/Aux Menu for controlling the “AUX 3” Push Button

This menu shows only if no Special Crane Configurations are selected (Switch 3 positions 5-7).

This programming redefines the function of the (AUX 3) button just above the E-STOP.

(If a three motor crane use “Aux”, for standard four motor use “Motor”, for Select function use Select).

If replacing a pendant transmitter: if Switch 4 on the pendant transmitter has position 1 “OFF” and position 2 “ON” use “Motor”, if Switch 4 has position 1 “ON” and position 2 “ON” use “Select”.

For **three motor stand system** this button is an auxiliary relay control button. (AUX 3).

For **four motor systems** this button controls a main and aux motor such as a hoist. (See Section 5. Operation for details on the operation of this button.) To program a fourth motion select (Motor). This four motor application can only be used with special crane configuration TABLE 2(H) Standard 2-Speed 4 Motor System. The AUX 3 button becomes a switch to toggle between “A” and “B” or both. Where “A” and “B” are main and auxiliary motors respectively. The main motor output is motor 1 and the auxiliary motor output is motor 4.

For up to **5 motors** using the **select function** this button is available to use select relays. This select function can only be used with special crane configuration TABLE 2(I) Standard 2-Speed 3, 4 & 5 Motor System using Select. To program in the select function tap the word “Select”.

Tandem For Hoist, Trolley or Bridge. (Normally checked).

This function appears if a four motor system or select function is chosen. Normally the box is checked meaning “Both A and B” operation is enabled (both MAIN and Aux or Select 1 and Select 2 can be ON at the same time). Removing the check from the box by tapping on it disables the “Both” function. (“A” and “B” will not come ON at the same time). This function maps to Pendant Switch 4 position 3, if SW4 position 3 is switched “ON” un-check Tandem box on PDA.

Section 7 - Programming (Continued)

Position 4 Invert Crane Select Aux. Outputs. (Normally not checked).

This function appears if a system using select is programmed in. Turning this switch “ON” inverts the select function operation so that the relay closes for the unselected function. This function maps to Pendant Switch 4 position 4, if SW4 position 4 is switched “ON” check Invert box on PDA.

The screenshot shows the 'Setup Bank #' screen for a 10K system. At the top, 'System' is set to '10K' and 'Freq' is set to 'AK01'. Below these are two 8-bit binary displays: 'A1' and 'B1', both showing '1' in the top bit and '0' in the bottom bit. Underneath is the 'Receiver access code' section with checkboxes for 'Multibox' and 'Auto Turn Off', and a 'Tx #' dropdown set to '1'. The 'S3-1' display shows '1' in the top bit and '0' in the bottom bit, with a 'Timer' dropdown. The 'Switch conf.: H,T,B' section has a 'Main/Aux' dropdown set to 'Aux'. At the bottom, there are checkboxes for 'Tandem', 'Invert', and 'Crane control enabled'. 'Save' and 'Cancel' buttons are also present.

10K 2-Speed Programming Screen

This completes the 10K 2-speed programming, when completed with the above tap “Save”.

Save will take you back to the Initial start screen. At this point select another Bank to program or go to Section 7-9. Saving And Loading The Program.

Section 7 - Programming (Continued)

7-8.1.3. Single-Speed 10K telePilot Lockout Modes.

The Modes shown are equivalent to the same Modes in the single-speed Membrane transmitter. Auxiliary relay functional labeling shown is in reference to the traditional labeling of the Single-Speed Membrane Transmitter for the respective modes. Each pair of directionals shown for its respective mode is locked out.

The dark rectangles on the drawings below represent buttons pairs that are locked out from both working at the same time.

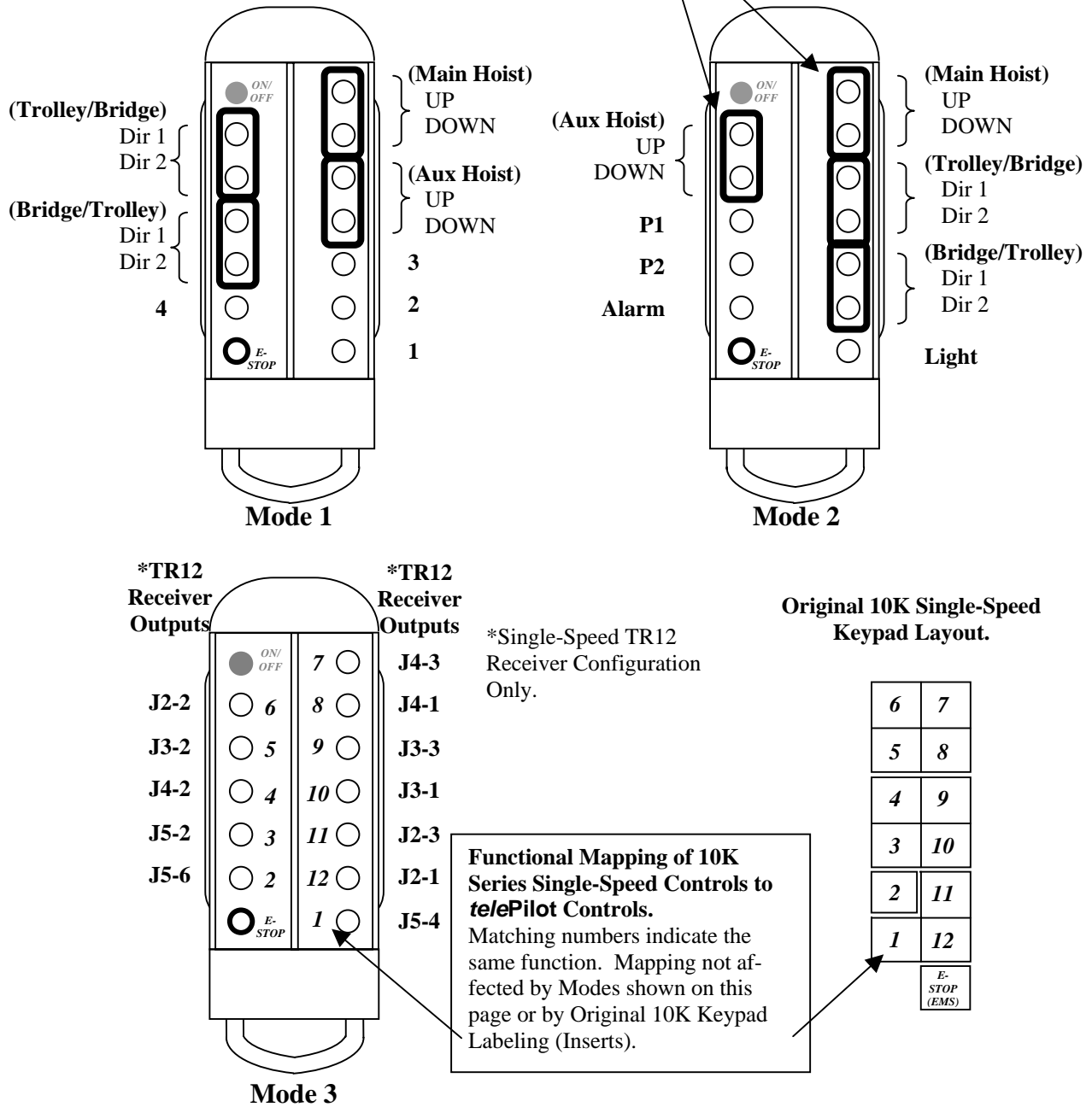

Figure 7-7. Single-Speed 10K telePilot Modes.

Section 7 - Programming (Continued)

7-8.2. 9000 and 9001 telePilot Programming.

After you have entered 9000 or 9001 as your system type enter the following items in order for your system:

Frequency (Must be inputted for system to work):

There should be a label either on the receiver or the transmitter listing frequency, it should be a channel number between A to K. Find this letter and tap the “Freq” arrow and select that channel letter. As the frequency letter is entered the last five positions of the programming automatically sets itself to the positions used in previous 9000(1) systems to program in that frequency.

If you are unable to find a channel letter designation for frequency, copy the last 5 positions of the access code dip switch, from an existing unit. The correct channel number will appear in the “Freq” window.

9000(1) Channel Code versus Frequency.

Channel	Frequency	Channel	Frequency
A	448.0 MHz	F	447.5 MHz
B	448.5 MHz	G	447.1 MHz
C	449.0 MHz	H	446.7 MHz
D	449.5 MHz	J	446.3 MHz
E	450.0 MHz	K	445.9 MHz

Access Code (Must be inputted for system to work):

The first four positions of the switch shown is the access code copy these four switch positions from an existing piece of equipment.

Screen switch operation. The screen switches are labeled from left to right “A”, “B” and S3. They are numbered from left to right 1 to 8. The darkened rectangle to the bottom is “OFF” or “0” the darkened rectangle to the top is “ON” or a “1”. Tapping the lightened rectangle will cause the switch to toggle.

Auto Turn Off (Optional, can be skipped):

The telePilot transmitter has a variable length Time-out-timer. To facilitate operation of this timer with various models of receiver the Auto Turn Off feature was created. If this feature is enabled, when the transmitter times out and the transmitter turns OFF, it will before shutting down send an OFF command to the receiver. Check (tap) the box to enable.

Timer (If unsure of a number start with 15 minutes):

Enables the transmitter time-out-timer. The selections are “None” (meaning the transmitter will never shut off on it own if not used, this is not recommended for

battery life) or numbers of minutes till shut down. The minutes are selectable in one-minute steps from 1 to 10 and five minutes steps up to an hour. Tap on the “Timer” arrow; scroll down through the number of minutes and tap on the desired number.

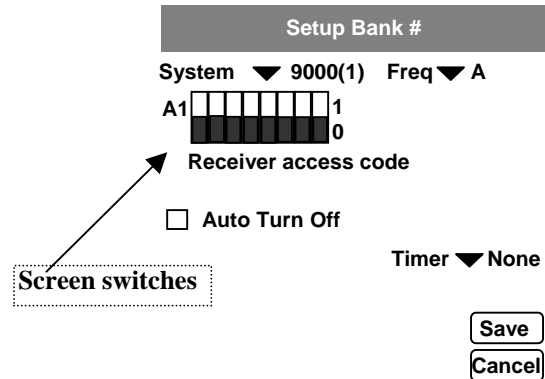

9000 and 9001 Programming Screen

This completes the 9000(1) programming tap “Save”.

Save will take you back to the Initial start screen. At this point select another Bank to program or to Section 7-9. Saving And Loading The Program.

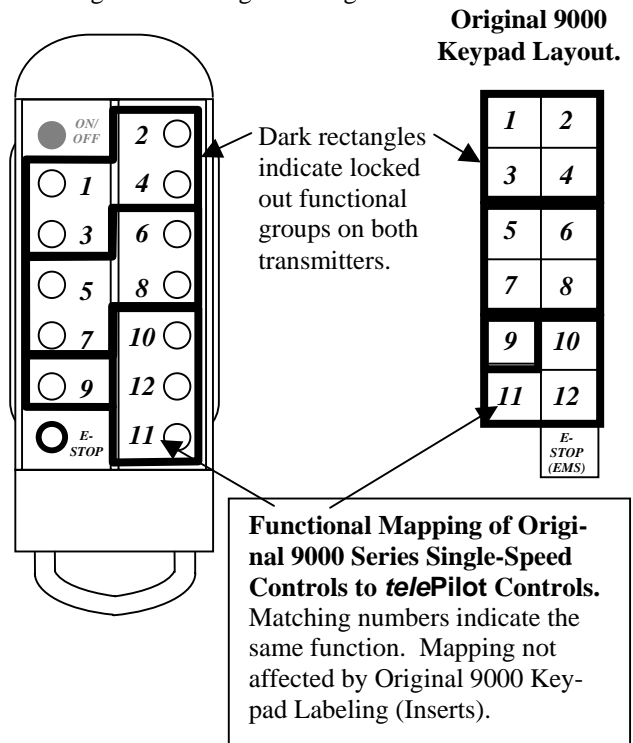

For functional mapping of 2-Speed Controls from 9001 to telePilot see Section 7-9.

Section 7 - Programming (Continued)

7-8.3. 9100 and 9101 telePilot Programming.

After you have entered 9100 or 9101 as your system type enter the following items in order for your system:

Frequency (Must be inputted for system to work):

There should be a label either on the receiver or the transmitter listing frequency, it should be a channel number between A to K. Find this letter and tap the “Freq” arrow and select that channel letter. As the frequency letter is entered the last five positions of the programming automatically sets itself to the positions used in previous 9100 and 9101 systems to program in that frequency. For specific frequency information see the Channel Code versus Frequency listing below.

If you are unable to find a channel letter designation for frequency, copy the last 5 positions of the access code dip switch, from an existing unit. The correct channel number will appear in the “Freq” window.

9100(1) Channel Code versus Frequency.

Channel	Frequency	Channel	Frequency
A	448.0 MHz	F	447.5 MHz
B	448.5 MHz	G	447.1 MHz
C	449.0 MHz	H	446.7 MHz
D	449.5 MHz	J	446.3 MHz
E	450.0 MHz	K	445.9 MHz

Access Code (Must be inputted for system to work):

The first four positions of the switch shown is the access code copy these four switch positions from an existing piece of equipment.

Screen switch operation. The screen switches are labeled from left to right “A”, “B” and S3. They are numbered from left to right 1 to 8. The darken rectangle to the bottom is “OFF” or “0” the darken rectangle to the top is “ON” or a “1”. Tapping the lighten rectangle will cause the switch to toggle.

Auto Turn Off (Optional, can be skipped):

The telePilot transmitter has a variable length Time-out-timer. To facilitate operation of this timer with various models of receiver the Auto Turn Off feature was created. If this feature is enabled, when the transmitter times out and the transmitter turns OFF, it will before shutting down send an OFF command to the receiver. Check (tap) the box to enable.

Timer (If unsure of a number start with 15 minutes):

Enables the transmitter time-out-timer. The selections are “None” (meaning the transmitter will never shut off on it own if not used, this is not recommended for battery life) or numbers of minutes till shut down. The minutes are selectable in one-minute steps from 1 to 10 and five minutes steps up to an hour. Tap on the “Timer” arrow; scroll down through the number of minutes and tap on the desired number.

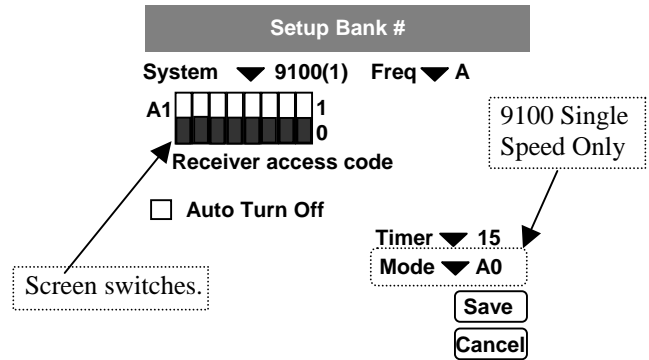

9100 and 9101 Programming Screen

Modes A0-A4 (9100 Single-Speed Only). (The correct mode must be selected for safe operation):

Please refer to **Figure 7-8. Single-Speed 9100 telePilot Lockout Modes** for specific mode details and functional mapping of 9100 controls to telePilot. Modes are various patterns of functional lockouts. If you have UP and a DOWN buttons on a single-speed transmitter controlling a hoist, the transmitter must not be able to send Up and DOWN commands at the same time. Mode determines the respective buttons that are locked out to each other. Modes do NOT change the configurations of the output relays. Find the desired mode and select its number on the “Mode” selection.

For functional mapping of 2-Speed Controls from 9001 to telePilot see Section 7-9.

This completes the 9100(1) programming, when completed with the above tap “Save”.

Save will take you back to the initial start screen. At this point select another Bank to program or go to Section 7-9. Saving And Loading The Program.

Section 7 - Programming (Continued)

7-8.4. Single-Speed 9100 Series *telePilot* Lockout Modes.

The Modes and Mode labeling shown relate to the similar, but not identical, Modes in the Single-Speed 9100 Transmitter. Choose the lockout pair that most closely matches your needs. If you are unsure of the Lockout Mode in your existing unit, read dip switch SW3 in the existing 9100 transmitter and compare it to the chart below. Lockout pairs are shown below:

Original 9100 SW3 Transmitter dip switch settings:

SW3 Switch			Use Mode
1	2	3	
ON	ON	ON	A0
OFF	ON	ON	A1
OFF	OFF	ON	A2
ON	ON	OFF	A3
OFF	ON	OFF	A4
ON	OFF	ON	NA
ON	OFF	OFF	NA
OFF	OFF	OFF	NA

NA means not applicable

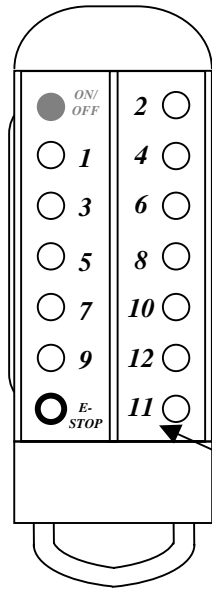

Mode A0

Original 9100 Keypad Layout.

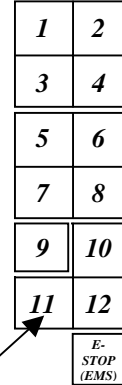

Functional Mapping of 9100 Series Single-Speed Controls to *telePilot* Controls.

Matching numbers indicate the same function. Mapping not affected by Modes shown below or by Original 9100 Keypad Labeling (Inserts).

The dark rectangles on the drawings below represent buttons pairs that are locked out from both working at the same time.

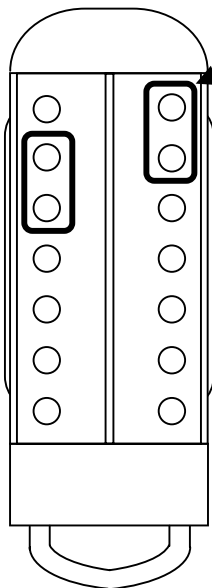

Mode A1

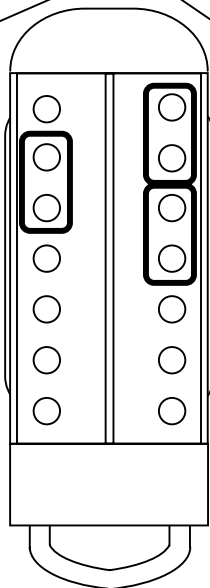

Mode A2

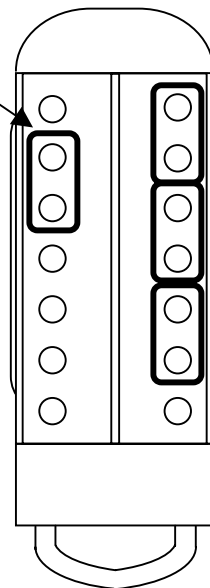

Mode A3

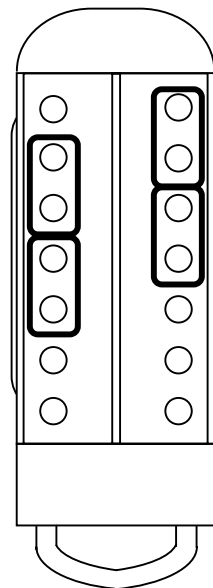

Mode A4

Figure 7-8. Single-Speed 9100 *telePilot* Lockout Modes.

Section 7 - Programming (Continued)

7-8.5. 2-Speed 9001 and 9101 Series *telePilot* Functional Mapping.

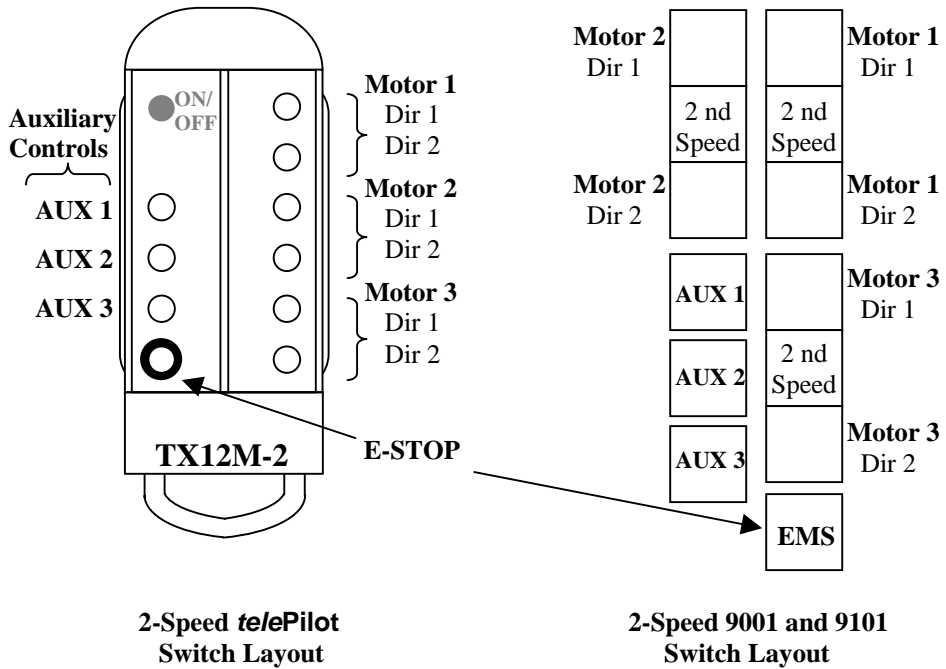

Figure 7-9. Functional Mapping of 9001 and 9101 Series 2-Speed Controls to *telePilot* Controls.

Matching designators indicate the same function.
 Mapping not affected by Keypad Labeling (Inserts).

Section 7 - Programming (Continued)

Saving, Downloading, Reading The Programs and Other PDA Functions.

Saving The Programming File.

With the initial *telePilot* screen displayed, tap in the lower left corner of your PDA, the title bar at the top of the screen will show a menu or tap on the word “*telePilot*”. Choose the way you wish to save the file. Tap on your choice and follow the instructions on the PDA to complete file saving. Old files can be deleted, called up, modified and renamed by this same menu.

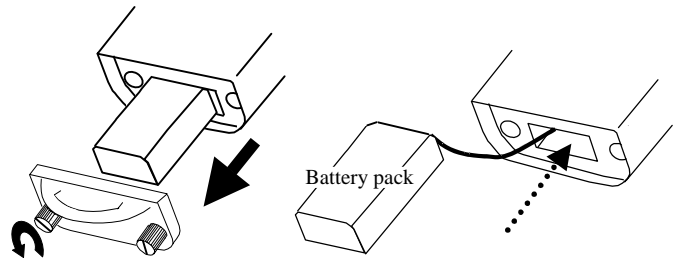
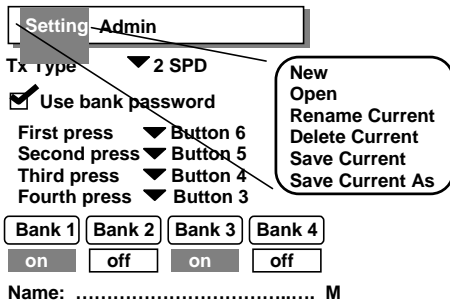

Figure 7-9. *telePilot* Infrared Port Access.



2. Turn transmitter unit ON. Note that the Tx Red LED is ON.
3. From the application file's main menu click on the PDA a dropdown menu icon located at bottom left corner or tap on the word “Programmer” at the top of the screen. Select “Admin.”
4. Under “Admin.” select “Send Setting.”

Sending a Program To The *telePilot*.



WARNING

AFTER EVERY PROGRAMMING OF THE TRANSMITTER, TEST THE UNIT BY TURNING IT ON AND OFF NEAR THE APPROPRIATE RECEIVER. IF THE RECEIVER DOES NOT RESPOND, DO NOT ACTIVATE A FUNCTION BUTTON! THE TRANSMITTER MAY HAVE INCORRECT PROGRAMMING, WHICH COULD MOVE ANOTHER CRANE. RE-CHECK THE PROGRAMMING IN THE TRANSMITTER AND RETEST. AFTER ACTIVATION OF RECEIVER, FUNCTIONALLY TEST ALL COMMANDS ON THE TRANSMITTER BY INITIALLY JOGGING THE BUTTONS, THEN WITH A FULL MOVEMENT BEFORE RETUNING TO SERVICE. FAILURE TO FOLLOW THIS WARNING COULD RESULT IN SERIOUS INJURY OR DEATH AND DAMAGE TO EQUIPMENT.

To send a program file which consists of four banks to a *telePilot* Transmitter:

1. Line up the PDA's infrared port with the transmitters infrared port (remove battery end cap and pull battery pack back and expose the *telePilot*'s infrared port. See Figure 7-9. *telePilot* Infrared Port Access).

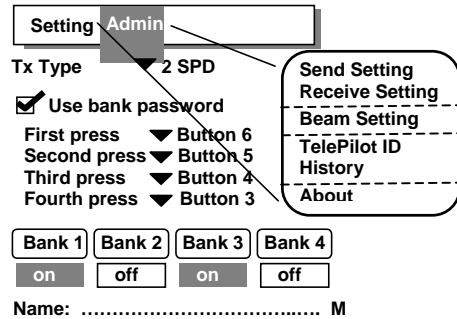

5. Select a name you want for the *telePilot* unit being programmed and tap “OK”.
6. Wait for confirmation text on PDA screen:
7. After programming, always operationally test all the functions the transmitter by using the appropriate receiver with the MR relay disabled before retuning transmitter to service.

Receiving (Reading) The *telePilot* Programming.

To read a program file from the *telePilot* Transmitter:

1. Line up the PDA's infrared port as sets 1 to 3 above, with the transmitter ON. Select “Admin”
2. Select “Receive Setting.”
3. PDA will confirm reception and automatically display current programming in the *telePilot* unit.

Section 7 - Programming (Continued)

Reading The *telePilot* ID.

To read an identity (an identity is the name that was programmed in by step 5 of Sending a Program To The *telePilot*, listed above) from the *telePilot* Transmitter:

1. Line up the PDA's infrared port as sets 1 to 3 above, with the transmitter ON. Select "Admin"
2. Select "*telePilot* ID."
3. PDA will read: Name, Serial/Job Number, and Manufacturing information of the *telePilot* unit.

Reading The *telePilot* History.

To read Service information from the *telePilot* Transmitter:

1. Line up the PDA's infrared port as sets 1 to 3 above, with the transmitter ON. Select "Admin"
2. Select "History"
4. Unit will read: Past Service Orders of the *telePilot* unit.

Reading The PDA *telePilot* Software Version.

To read PDA Software Version from the *telePilot* Transmitter:

1. Select "Admin"
2. Select "About"
3. Unit will read: *telePilot* Programmer Software Version number.

Beaming (Sending) the Configuration(s) to another PDA.

To send a configuration setting to another PDA.

1. Line up the PDA's infrared port as, with the other PDA, which is turned ON.
2. Select "Beam Setting."
3. Select the item(s) you wish to send.
4. Wait for confirmation text on PDA screen:

Error Statements and Codes.

Tx Type Mismatch; If while attempting to program a *telePilot* you receive an error code such as "Error AAAB" you have selected a different style transmitter on the PDA than you are attempting to program. Most common cause is trying to program a 2-speed *telePilot* with single-speed selected or visa versa.

Section 8 – Servicing

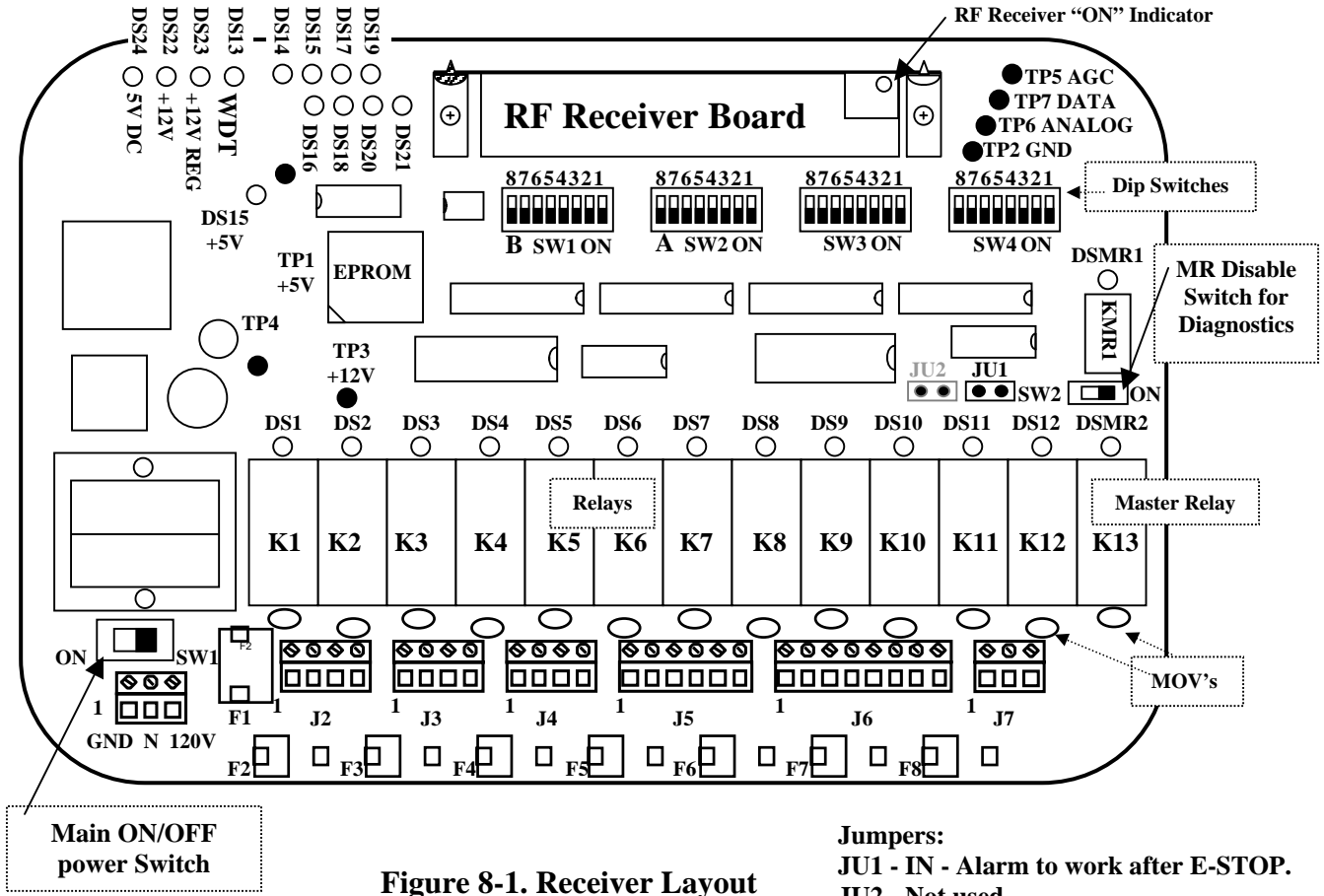

Figure 8-1. Receiver Layout

Jumpers:
 JU1 - IN - Alarm to work after E-STOP.
 JU2 - Not used.

NOTE

IF THE SYSTEM STOPS WORKING CHECK THE RED INDICATOR ON THE TRANSMITTER. IF IT DOES NOT COME ON WITH PUSHING THE ON BUTTON OR THE YELLOW WEAK BATTERY LIGHT IS ON (FOR THE *telePilot* TRANSMITTER) REPLACE THE TRANSMITTER BATTERIES.

Table 8-1. Receiver Diagnostic LED Functions. (See Figure 8-1. Receiver Layout for LED locations).

LED	COLOR	FUNCTION
RF Receiver ON	Red	Power is on to the RF Receiver. Normally ON. Monitors power to the RF Receiver Board. If the main receiver is ON and the RF Receiver ON LED is OFF. Check to see if the RF Receiver Board is properly plugged in to the main board.
DSMR1	Yellow	Monitors closure of the Security Relay output (KMR1). The LED will be illuminated when the Security Relay has been enabled by an ON command received from the Transmitter Unit. LED will extinguish when an OFF command is transmitted, or an EMS condition is present. The Security Relay controls the 12 VDC power to the MCR relay (K13) and the power to the coils of the control relays (K1 through K12) on the Relay Output Modules.

Section 8 – Servicing (Continued)

DSMR2	Red	<p>Monitors closure of the Master Control Relay (MCR) relay (K13).</p> <p>LED will be illuminated when the MCR relay has been enabled by an ON command received from the Transmitter Unit. Led will extinguish, when an OFF command has been transmitted, an EMS condition is present, or SW2 is set to OFF.</p> <p>The MCR controls the 12 VDC power to the Master Relay on the Power Supply Board.</p>
DS1-DS12	Red	<p>Monitors closure of the output relays (K1-K12).</p> <p>Normally ON for a function when that specific function is enabled.</p> <p>The LED will be illuminated when a specific relay has been enabled by the respective command received from the Transmitter Unit. The LED will extinguish, when the command is no longer detected.</p>
DS13	Red	<p>Monitors the watchdog timer.</p> <p>Normally OFF.</p> <p>The LED will illuminate momentarily when power is applied to or removed from the system. If the LED is continuously flashing or on, the computer is not working properly. If LED is illuminated constantly (no flashing), the +5 VDC is probably too low. This could be caused by shorts on the board or by a defective voltage regulator. If the LED flashes at a constant rate, the microcomputer chip or EPROM may be defective.</p>
DS14	Yellow	<p>Monitors data synchronization. (Flashes when a properly formatted data signal is received from the transmitter).</p> <p>This LED will flash rapidly when data is transmitted. The LED can be used with DS16 to analyze incoming data. If DS16 is illuminated or flashing when DS14 also is flashing, another Transmitter Unit on the same frequency may be present. This is normal. As more Transmitter Units operated on the same frequency, LED will flash brighter and more often.</p>
DS15	Yellow	<p>Monitors continuity between receiver RF module and CPU module.</p> <p>Normally ON.</p> <p>Off indicates a malfunctioning receiver.</p>
DS16 Check this first!	Red	<p>Monitors received data errors. Wrong Access Code.</p> <p>Normally OFF.</p> <p>If LED is illuminated continuously when data is transmitted and the system will not respond the Access Code of the Receiver and Transmitter Units may not match. A flashing LED during data transmission may indicate interference of the received data. If LED is illuminated when data is not transmitted, another Transmitter Unit may be present on the same frequency with a different Access Code. The presence of activity on this LED does not necessarily indicate a problem. It should be used with other indicators in analyzing system status.</p>
DS17	Yellow	<p>Monitors system activity.</p> <p>Normally FLASHING.</p> <p>If not flashing the microprocessor is dead.</p>
DS18	Red	<p>Monitors the ON command from the Transmitter.</p>

Section 8 – Servicing (Continued)

		LED will flash when an ON command is being received from the Transmitter. While pushing the ON button on the Transmitter this should light.
DS19	Red	Monitors EMS condition. Normally OFF. LED will flash when an EMS command is transmitted and illuminate continuously when the EMS condition is in effect. An EMS condition may be created when an EMS command is transmitted or when a failure mode is detected by the slave microcomputer. If both DS18 and DS19 are illuminated, a contact monitoring error has been detected. If both DS16 and DS19 are illuminated, the incoming data on the ICC bus has been corrupted.
DS20	Red	Monitors the OFF command from the Transmitter. LED will flash when an OFF command is being received from the Transmitter Unit. While pushing the OFF button on the Transmitter this should light.
DS21	Yellow	Monitors the activity for the Security Relay (KMR1). Normally ON when the receiver is enabled. If the system is ON and the light is not lit there is a serious microprocessor error.
DS22	Green	Monitors the unregulated DC power to the 12 volt regulator Normally ON when AC line is present. If AC Power is present and the AC to DC converter is working then the LED is illuminated. The LED is off if DC power is not present. Check power supply, fuses and if power is applied to the receiver.
DS23	Green	Monitors the regulated 12 VDC power to the Board (receiver board). Normally ON when AC line is present. If 12 VDC power is present then the LED is illuminated. The LED is off if 12 VDC power is not present. Check the 12 VDC regulator and for shorts on the Board.
DS24	Green	Monitors regulated 5 VDC power to the Board. Normally ON when AC line is present. If 5 VDC power is present then the LED is illuminated. The LED is off if 5 VDC power is not present. Check the 5 VDC regulator and for shorts on the Board.

8-2. Receiver Testing.

8-2.1. Receiver test points.

Test points are shown as dark circles on Figure 8-1. Receiver Layout.

TP1 – Monitors regulated 5 VDC.

TP2 – Ground for monitoring other test points.

TP3 – Monitors regulated 12 VDC.

TP4 – Not used.

Section 8 – Servicing (Continued)

NOTE

THE FOLLOWING TEST POINTS NEED AN OSCILLOSCOPE, SEE 8-2. RECEIVER SCOPE WAVE FORMS.

TP5 – Monitors AGC (Automatic Gain Control) from RF Receiver module.

TP6 – Monitors analog signal from RF Receiver module.

TP7 – Monitors received data from RF Receiver module.

8-2.2. Typical Wave Forms on an Oscilloscope.

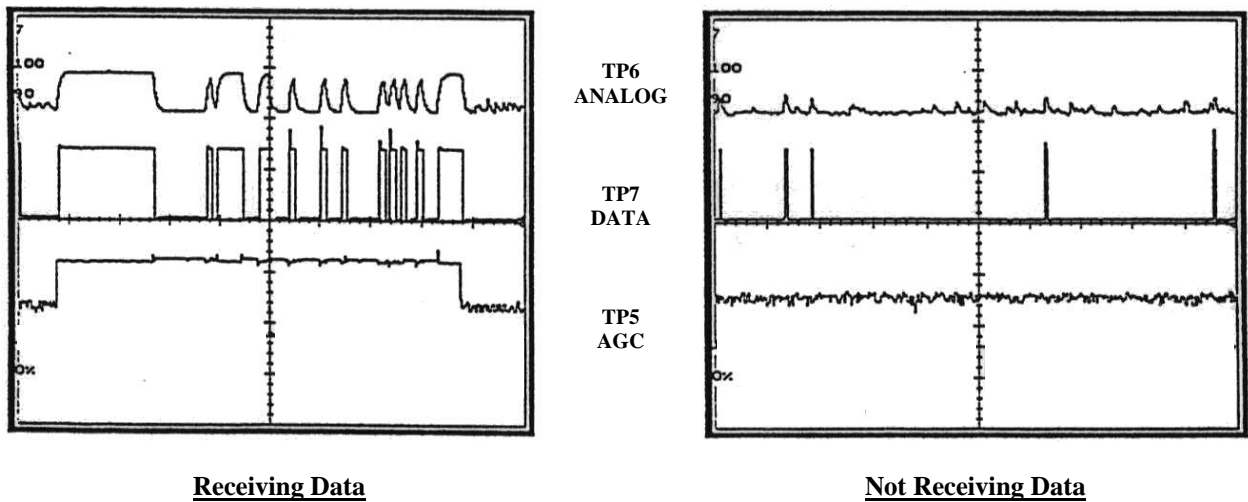

Figure 8-2. Receiver Scope Wave Forms.

Scope Settings:

- Sweep – 1 millisecond per division.
- Sensitivity – TP6, 1 volt per division 10X probe.
TP7, 2 volts per division 10X probe.
TP5, 1 volt per division 10X probe.

Section 8 – Servicing (Continued)

8-3. Membrane Transmitter Servicing.

The Membrane Transmitter M/C board is shown in Figure 8-3. Refer to paragraphs below for Servicing Procedures.

NOTE
TO DISABLE TIME-OUT-TIMER
IN TRANSMITTER TURN SW3
POSITION 3 TO ON.

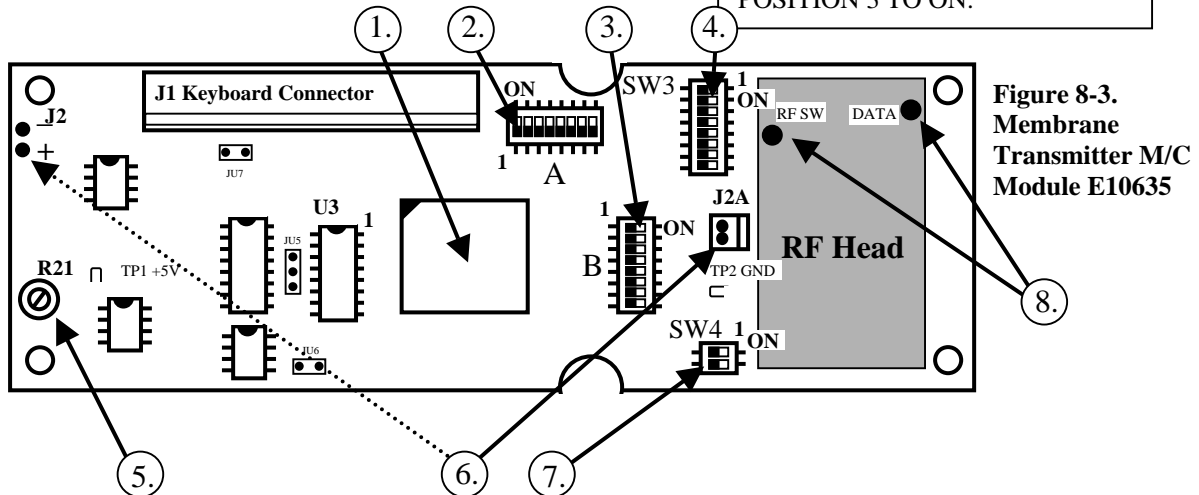

Figure 8-3.
Membrane
Transmitter M/C
Module E10635

- | | | |
|--|--|---|
| 1.) EPROM FW2903-0
Tactile 2-SP, FW2904-0T
1 & 2-SP Non-tactile. | 4.) SW3 Two-Speed Mode
Switch. | 6.) Battery Cable
Connections, J2A plug
and J2 alternate style. |
| 2.) SW1 "A" Access Code
Switch. | 5.) Battery Monitor
Adjustment. Set for 5.8
Volts. | 7.) SW4 Single-Speed Mode
Switch. |
| 3.) SW2 "B" Access Code Switch. | | 8.) Data check points. |

8-3.1. To Check Data.

- 1.) For data input use "DATA" connection to RF Head
- 2.) Use "RF SW" for External Trigger input.
- 3.) Use TP2 for Ground

8-3.2. Battery Monitor Adjustment.

Connect power supply to battery leads observing polarity and set supply voltage to 5.8 volts. Adjust Battery Monitor Potentiometer R21 to just turn off red LED on the front of the transmitter.

8-3.3. Red LED Not Flashing.

If the red LED indicator on the transmitter does not flash when the transmitter is turned ON or

while operating crane with the transmitter, replace the batteries they are weak. Weak batteries may operate the crane for a while, but the LED will not flash. If the battery is too low the battery monitor will shut the transmitter OFF. See Section 5-6. Battery Replacement for proper procedure.

NOTE

IF THE BATTERIES ARE INSTALLED BACKWARDS IN THE MEMBRANE TRANSMITTER THE FUSE IN THE BATTERY COMPARTMENT WILL BLOW TO PROTECT THE INTERNAL CIRCUITRY.

8-3.4. Battery Fusing.

The Membrane Transmitter is protected from reverse battery polarity and shorts by a fuse, part number F2712-1.5 (1.5 Amp, 250V, Fast Acting, 2 AG). If the batteries are installed in backwards this fuse will blow to protect the internal electronics

Section 8 – Servicing (Continued)

8-4. Pendant Transmitter Servicing.

The Single-Speed or the 2-Speed 10K12 Pendant Transmitter may be used with the 10K6/9 Receiver. The Pendant Transmitter M/C Board is shown in Figure 8-4. Refer to paragraphs below for Servicing Procedures.

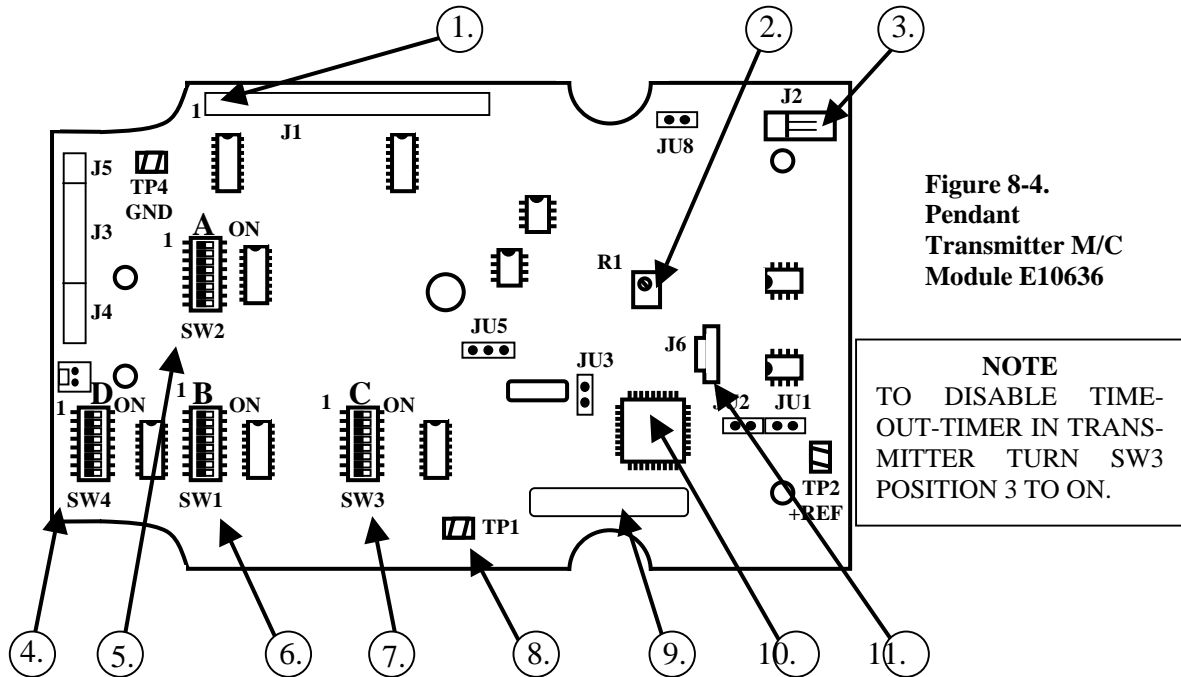

Figure 8-4.
Pendant
Transmitter M/C
Module E10636

NOTE
TO DISABLE TIME-
OUT-TIMER IN TRANS-
MITTER TURN SW3
POSITION 3 TO ON.

- | | | |
|--|--|---|
| 1.) J1 Pin 1 Data Input. | 5.) SW2 "A" Access Code Switch. | 8.) Test Point 1 External Trigger for Data. |
| 2.) Stepless Switch Level Adjustment. (Factory Set). | 6.) SW1 "B" Access Code Switch. | 9.) Software version label. |
| 3.) Battery Connector. | 7.) SW3 "C" Configuration Switch. SW3 position 8 "ON" disables Time-out-timer. | 10.) Flash ROM. |
| 4.) SW4 "D" Mode Switch. | | 11.) Flash ROM Serial Programming Port. |

8-4.1. To Check Data.

- 1.) For data input use pin 1 of J1.
- 2.) Use TP1 for External Trigger input.
- 3.) Use TP4 for Ground.

8-4.2. Battery Monitor Adjustment.

Battery monitor is factory preset no adjustment available.

8-4.3. Red LED Not Flashing.

If the red LED indicator on the transmitter does not flash when the transmitter is turned ON or while operating crane with the transmitter, replace the batteries, they are weak. Weak batteries may operate the crane for a while, but the LED will not flash. If the battery is too low the battery monitor will shut the transmitter OFF. See Section 5-6. Battery Replacement for proper procedure.

Section 8 – Servicing (Continued)

8-4.4. Stepless Switch Adjustment.

R1 is factory preset and controls the upper level of the stepless switch range.

8-4.5. Pendant Transmitter Software.

There is no EPROM in the Pendant Transmitter; software is stored internally in non-volatile flash memory. Software updates are done in the factory through the serial port. A software version label on the board indicates the software version loaded into flash memory.

8-5. *telePilot* Servicing.

There are no user adjustments inside the *telePilot* unit. All internal adjustments are done by software. Internally there is a single circuit board that requires proper handling to replace. The individual switch packs can be replaced without opening the unit. Contact Telemotive Customer Care for details. See Figure 9-1. *telePilot* Exploded View View.



Section 9 – Spare Parts

RECEIVER

PART NUMBER	DESCRIPTION
FW2912-0	EPROM
E13157-S	RF SYNTHESIZED RECEIVER MODULE ASSEMBLY
H310-0	RF RECEIVER MODULE ASSEMBLY MOUNTING SCREWS (4)
MP18005-0	RF RECEIVER MODULE MOUNTING BRACKET TOP SIDE (LEFT)
MP18005-1	RF RECEIVER MODULE MOUNTING BRACKET TOP SIDE (RIGHT)
H906-0	RF RECEIVER MODULE MOUNTING BRACKET BOLT (2)
H934-0	RF RECEIVER MODULE MOUNTING BRACKET NUT (2)
E10199-0	MAIN BOARD
H1224-1	MAIN BOARD MOUNTING SCREWS (5)
E10197-2	ANTENNA ASSEMBLY (INTERNAL)
	CONNECTOR PLUG IN:
TS1060-3	3 POSITION (2)
TS4655-4	3 POSITION (3)
J4655-0	6 POSITION
TS1060-8	8 POSITION
CR260-0	MOV
K1304-0	RELAY (OUTPUT) (13)
S2721-8	DIP SWITCH (ACCESS CODE) (4)
MP10276-0	HOUSING ASSEMBLY, WITH DOORS
H1223-1	SCREW ROUND HEAD #10-24 X 1 ½"
H1226-0	HEX NUT #10-24 (4)
H2079-0	LOCK WASHER #10 SPLIT
TCTX12/TR12-0	INSTRUCTION MANUAL
F2711-2	FUSE ½ AMP, SLO BLO 250V
F2711-0	FUSE 10 AMP SLO BLO 250V (7)
H1127-0	FUSE COVERS, VINYL (7)
WA12038-0	EXTERNAL ANTENNA ADAPTER (Does not include antenna).
A525-1	ANTENNA (For use with WA12038-0).
WA104-20	CABLE ASSMBLY, 20 FOOT (For remote antenna mounting requires WA12038-0 and A525-1).

telePilot TRANSMITTER (SEE FIGURE 9-1.)

PART NUMBER	DESCRIPTION
E10647-0	MAIN CIRCUIT BOARD 2-SPEED
E10727-0	MAIN CIRCUIT BOARD SINGLE-SPEED
N10705-0	LABELS
MP10620-0	SHOULDER STRAP
TCTX12/TR12-0	MANUAL
FW3045-0	PDA PROGRAMMING SOFTWARE
MP10709-0	BELT LOOP ASSEMBLY
A10708-0	BATTERY DOOR ASSEMBLY
H1113-0	HEX STANDOFF (4)
H1114-0	ROD, ALL THREAD, 2-SPEED (2)
H1121-0	ROD, ALL THREAD, SINGLE-SPEED (2)
E10713-0	SWITCH PACK 2-SPEED RIGHT
E10712-0	SWITCH PACK 2-SPEED LEFT
E10715-0	SWITCH PACK SINGLE-SPEED RIGHT
E10714-0	SWITCH PACK SINGLE-SPEED LEFT
WA1050-0	SWITCH RIBBON CABLE (2)
MP10706-0	TOP END CAP
MP10707-0	BOTTOM END CAP
A10724-0	HOUSING ASSEMBLY SINGLE-SPEED

Section 9 – Spare Parts (Continued)

telePilot TRANSMITTER CONTINUED (SEE FIGURE 9-1.)

PART NUMBER	DESCRIPTION
A10722-0	HOUSING ASSEMBLY 2- SPEED
WA1052-0	BATTERY CABLE, 2-SPEED
WA1053-0	BATTERY CABLE, SINGLE-SPEED
MP10721-0	BATTERY HOLDER FOR TWO "AA" CELLS
BT111-0	DISPOSABLE HIGH CAPACITY BATTERY PACK
BT111-1	RECHARGEABLE BATTERY PACK
A10723-0	BATTERY CHARGER FOR BT111-1

MEMBRANE TRANSMITTER

PART NUMBER	DESCRIPTION
F2712-1.5	FUSE 1.5 AMP, 250V FAST ACTING 2 AG
FW22903-0	TWO SPEED TACTILE MEMBRANE EPROM FOR TRANSMITTER M/C MODULE E10635
A9654-0	STRAP ASSEMBLY
A10662-1	TRANSMITTER CASE ASSEMBLY
E9654-0	BATTERY HOLDER ASSEMBLY
A10664-2	BATTERY DOOR ASSEMBLY
E10640-2	BEZEL ASSEMBLY (2-SPEED TRANSMITTER)
S2803-0	MEMBRANE SWITCH PAD (TACTILE)
MP9656-0	VINYL POUCH
A9665-0	RUBBER BOOT ASSEMBLY
BT646-0	BATTERY AA CELL 1.5 VOLTS (5)

PENDANT TRANSMITTER

PART NUMBER	DESCRIPTION
MP10668-1	CASE ONLY, TOP PENDANT TRANSMITTER
H634-0	BOOT, GRAY (PUSHBUTTON)
H635-0	BOOT, RED (PUSHBUTTON)
H2055-3	LENS/MOUNT, LED W/SPACER, RED
S1058-0	SWITCH, PUSHBUTTON, 2-SPEED SBRU-SD
S1026-0	SWITCH, PUSHBUTTON, MOM N/O
S1041-0	SWITCH, TOGGLE, SPDT, CTR OFF
MP10666-0	KNOB, ROTARY 1/2" DIA., BLACK
MP10675-0	BOOT, TOGGLE SW., BLACK
A10667-5	BOTTOM CASE W/O BATTERY DOOR
A10669-1	BATTERY DOOR W/FOAM, W/O SCREWS AND LATCH
MP10676-0	FOAM, BATTERY DOOR
MP10677-0	GASKET FOR BOTTOM CASE
H1047-0	COVER SCREWS (8)
MP1049-0	SWITCH GUARD
E10668-11LT	SAME AS E1066-11 BUT WITH SWITCH GUARD AND LARGE TOGGLES
MP10668-3	CASE TOP ONLY, LARGE TOGGLES
MP10650-3	LATCH FOR BATTERY DOOR
S605-0	SWITCH, TOGGLE SPDT CENTER OFF, LARGE
A1011-X	BOOTS (6) (SEE *NOTE 1 BELOW FOR THE PROPER SUFFIX)
H251-0	SCREW FOR BATTERY DOOR LATCH
H252-0	WAVE WASHER FOR BATTERY DOOR LATCH
H2034-0	FLAT WASHER FOR BATTERY DOOR LATCH
N13653-2	FCC LABEL
E10688-0	BATTERY HOLDER ASSEMBLY, W/CABLE
MP10680-0	O'RING
MP10678-0	SHOULDER STRAP
BT10KP-0	BATTERY, ALKALINE

Section 9 – Spare Parts (Continued)

PENDANT TRANSMITTER CONTINUED

PART NUMBER	DESCRIPTION
BT10KP-1	BATTERY, NICAD
BT10KP-0	BATTERY, ALKALINE
BT10KP-1	BATTERY, NICAD
E10670-1	BATTERY CHARGER

*NOTE 1	<u>UP</u>	<u>DOWN</u>	<u>EAST</u>	<u>WEST</u>	<u>NORTH</u>	<u>SOUTH</u>
YELLOW	23	24	31	32	29	30
BLACK	3	4	11	12	9	10

Section 9 – Spare Parts (Continued)



CAUTION

DO NOT ATTEMPT TO OPEN OR SERVICE THE *TELEPILOT* UNIT. ONLY TRAINED QUALIFIED INDIVIDUALS SHOULD DO SERVICING. STRICT ANTI-STATIC HANDLING PROCEDURES MUST BE FOLLOWED. FAILURE TO FOLLOW THIS CAUTION COULD RESULT IN SERIOUS DAMAGE TO EQUIPMENT AND/OR VOID THE WARRANTY.

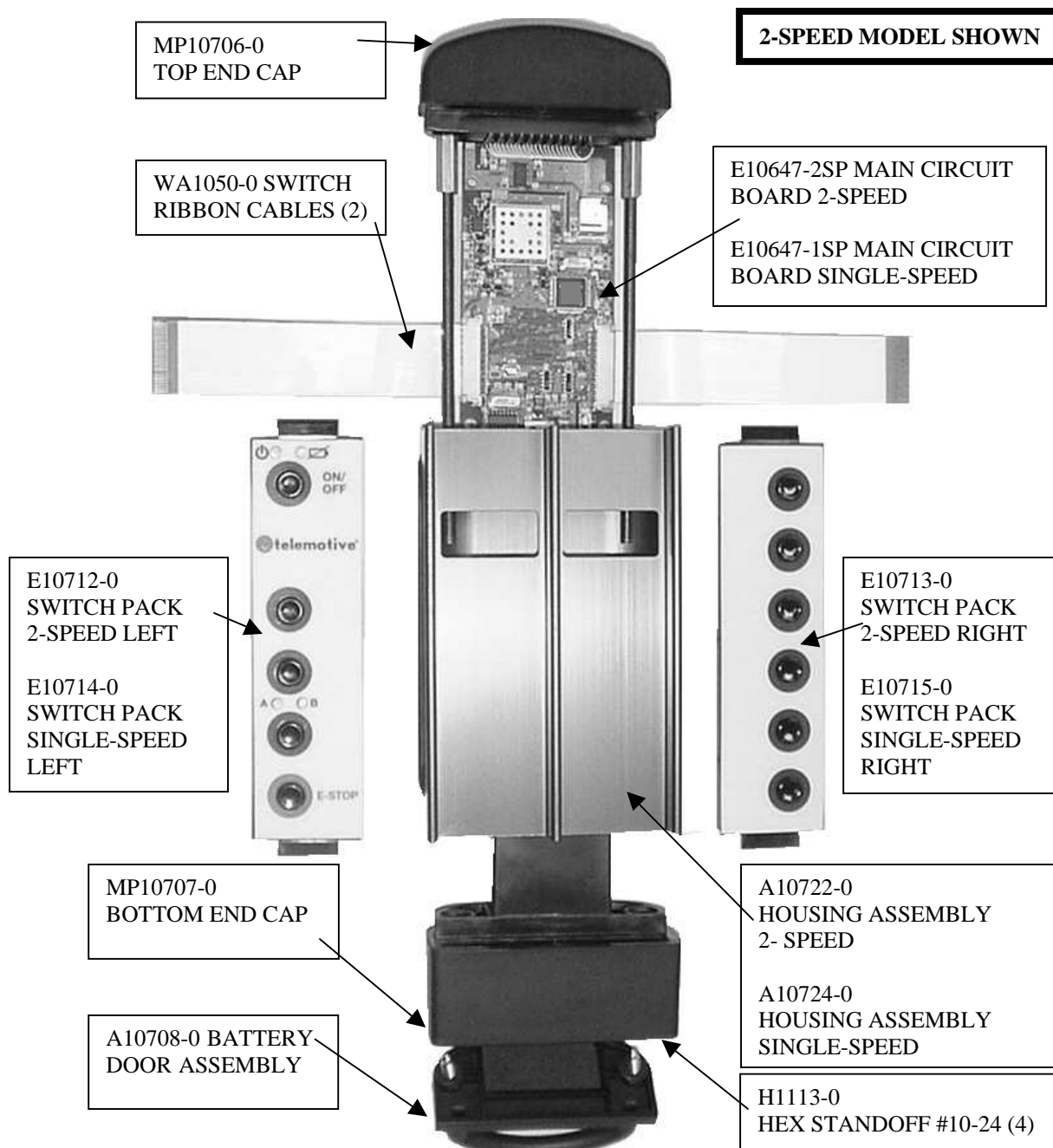

Figure 9-1. *telePilot* Exploded View.

Appendix A - Transmitter Switch Programming

Switch	POS.	Membrane	Pendant	SLTX	JLTX	telePilot
SW3	1	Switch Orientation 1	Switch Orientation 1	N/A	Code Plug Select	Switch Orientation 1
	2	Switch Orientation 2	Switch Orientation 2	N/A	N/A	Switch Orientation 2
	3	Switch Orientation 3	Switch Orientation 3	N/A	N/A	Switch Orientation 3
	4	Time-out-timer Disable	N/A	N/A	N/A	Time-out-timer Disable
	5	Crane Configuration 1	N/A	N/A	N/A	Crane Configuration 1
	6	Crane Configuration 2	RS232 enable	RS232 enable	RS232 enable	Crane Configuration 2
	7	Crane Configuration 3	N/A	N/A	Tilt Switch Disable	Crane Configuration 3
	8	N/A	Time-out-timer Disable	Time-out-timer Disable	Time-out-timer Disable	Time-out-timer Disable

SW4	1	Mode Enable See Table A below	Mode Enable See Table B below	Mode Enable See Table B below	Mode Enable See Table B below
	2	Mode Enable See Table A below	Mode Enable See Table B below	Mode Enable See Table B below	Mode Enable See Table B below
	3	N/A	Tandem Disable Un-check "Tandem" on <i>telePilot</i>	Tandem Disable Un-check "Tandem" on <i>telePilot</i>	Tandem Disable Un-check "Tandem" on <i>telePilot</i>
	4	N/A	Select Invert Check "Invert" on <i>telePilot</i>	Select Invert Check "Invert" on <i>telePilot</i>	Select Invert Check "Invert" on <i>telePilot</i>
	5	N/A	Crane Configuration 1 copy to <i>telePilot</i> S3-5	Crane Configuration 1 copy to <i>telePilot</i> S3-5	Crane Configuration 1 copy to <i>telePilot</i> S3-5
	6	N/A	Crane Configuration 2 copy to <i>telePilot</i> S3-6	Crane Configuration 2 copy to <i>telePilot</i> S3-6	Crane Configuration 2 copy to <i>telePilot</i> S3-6
	7	N/A	Crane Configuration 3 copy to <i>telePilot</i> S3-7	Crane Configuration 3 copy to <i>telePilot</i> S3-7	Crane Configuration 3 copy to <i>telePilot</i> S3-7
	8	N/A	N/A	N/A	N/A

SW4 POS. Table A (Membrane only)

Mode 0	1	OFF	
	2	OFF	Use 2-Speed <i>telePilot</i>
Mode 1	1	ON	
	2	OFF	Use Single-Speed <i>telePilot</i> "Mode 1"
Mode 2	1	OFF	
	2	ON	Use Single-Speed <i>telePilot</i> "Mode 2"
Mode 3	1	ON	
	2	ON	Use Single-Speed <i>telePilot</i> "Mode 3"

SW4 POS. Table B

Mode 1	1	OFF	For Single Speed Use Single-Speed <i>telePilot</i> "Mode 3"	For 2-Speed Transmitter Use 2-Speed <i>telePilot</i> Under "Main/Aux" use "AUX"
	2	OFF		
Mode 2	1	ON	Use 2-Speed <i>telePilot</i> Under "Main/Aux" use "Motor"	
	2	OFF		
Mode 3	1	OFF	Use 2-Speed <i>telePilot</i> Under "Main/Aux" use "Select"	
	2	ON		