

TELEMOTIVE

APPENDIX E

10K JLTX TRANSMITTER



MAGNETEK
UNCOMMON POWER

Material Handling Group

N49 W13650 Campbell Drive
Menomonee Falls, WI 53051
Phone: 800-288-8178 Fax: 262-783-3510
Website: www.telemotive.com

Appendix E –10K JLTx Transmitter (Continued)

This page intentionally left blank.

Appendix E –10K JLTX Transmitter (Continued)

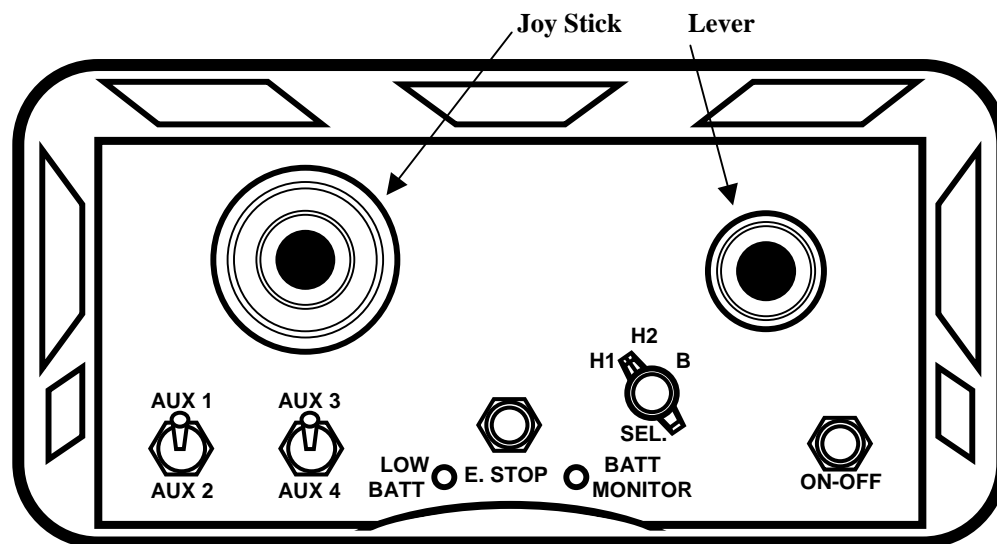

Figure E-1. Typical 10K JLTX Control Layout

E-1. JLTX Transmitter Operation.

Sections E-1.1. through E-1.10. describe the functional operation of the JLTX. Please refer to Figure E-1. Typical 10K JLTX Control Layout for control location.

E-1.2. Key Switch. (For Models So Equipped, disables power to transmitter circuitry only).

For models so equipped, turning the key off and removing it will disable the transmitter. Turning the key switch to on enables power to the transmitter unit, but does not activate the transmitter controls or turn on the receiver. The ON/OFF pushbutton must be pushed to turn the transmitter and receiver on or off. Under normal procedures it is recommended that the unit be turned off with the ON/OFF pushbutton before turning off the key switch. If the key switch is

turned off with the transmitter and receiver on, the key switch must be turned on again to use the ON/OFF pushbutton or E-STOP.

NOTE

FOR UNITS EQUIPPED WITH A KEY SWITCH. THE KEY IS TO BE USED FOR RENDERING THE TRANSMITTER DISABLED ONLY; IT DOES CONTROL THE RECEIVER OR POWER TO OR FROM THE RECEIVER.

E-1.3. "ON-OFF" Push-Button (Turns transmitter and receiver on and off).

(With the key switch engaged, for units with a key switch), pressing the ON/OFF push-button switch turns the transmitter and the receiver on. If the transmitter is on the BATT MONITOR

Appendix E –10K JLTX Transmitter (Continued)

light is on or flashing. Pushing the ON/OFF pushbutton again will turn the transmitter and receiver off. If the transmitter is out of range of the receiver, the receiver will not turn off until it times out. (For those units with receiver time-out-timer set active).

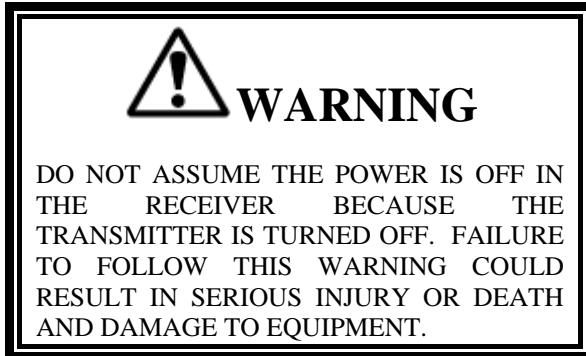

E-1.4. “E-STOP”. (For Emergency Stopping Only).

When depressed all equipment movement is immediately stopped. The transmitter must be turned off and on again to restore normal operation. To be used for emergency stopping only, not for normal system shut down. The E-STOP will not function with the optional key switch turned off.

NOTE

FOR MODELS EQUIPPED WITH THE RED MUSHROOM E-STOP. AFTER PRESSING THE E-STOP AND THE EMERGENCY STOP IS COMPLETED, TWIST THE E-STOP BUTTON CLOCKWISE TO RELEASE. FAILURE TO DO SO WILL IMPAIR BATTERY LIFE OF THE TRANSMITTER AND KEEP E-STOP ALARM ACTUATED IN THE RECEIVER.

E-1.5. “BATT MONITOR” Transmitter LED Indicator.

The transmitter LED (red) indicates on, transmitting and low battery voltage. A slow flash rate indicates the unit is on. A rapid flash rate indicates a unit is transmitting (when a function or control is activated). If the battery goes below a safe level the LED will not light, replace battery immediately.

E-1.6. “LOW BATT” Transmitter Aux. LED Indicator.

The Transmitter Aux. LED (red) indicates a low battery. When this LED is illuminated replace the battery immediately.

E-1.7. Joysticks Or Levers.

To activate motor functions, press and hold the push-button or lever that corresponds to the desired motion. To activate higher speed functions for those models so equipped press the motion switch or lever a little farther.

E-1.8. “SEL. H1, H2, or B” Rotary Selector Switch.

This rotary selector switch is used with the main and auxiliary hoist. Position “H1” activates the hoist lever to control only the main hoist, position “H2” gives activates the hoist lever to control only the auxiliary hoist and position “B” activates the hoist lever to control both the main and auxiliary hoist at the same time in tandem.

E-1.9. “AUX 1, AUX 2, AUX 3 and AUX 4” Auxiliary Switches.

These switches activate special function relays that control such items as such as alarms or lights depending on how the receiver is wired. The switches are momentary and activate the function as long as depressed.

E-1.10. Time-Out-Timer.

Unless this function is disabled the transmitter will turn itself off if not used for 15 minutes.

E-2. Transmitter Switch Programming.

Sections E2.1. through E2.4. describe transmitter Switches SW3 and SW4 Programming. (See Figure E-2 for physical location of transmitter switches SW3 and SW4).

E-2.1. Transmitter Switch Programming for Switch SW3.

E-2.1.1. SW3 Position 1 External Code Plug Enable. (Turn “ON” to enable external code plug).

For those models with external code plug this switch enables the external code plug. The switch causes the internal code plug to be read.

Appendix E –10K JLTX Transmitter (Continued)

E-2.1.2. SW3 Position 7 Tilt Switch Enable – (Turn “ON” to enable tilt switch for those units so equipped).

Switch SW3-position 7 turn “ON” to enable Tilt Switch.

E-2.1.3. SW3 Position 8 Time-out-timer Disable. (Normally keep turned “OFF”).

The transmitter has an approximate 15-minute time-out-timer. If the transmitter is not used for over 15 minutes it will shut down. This transmitter time-out-timer function is transmitter dip switch selectable. SW3 position 8 disables the time-out-timer. Turning SW3-8 “ON” disables the time-out-timer.

E-2.2. Transmitter Switch Programming for Switch SW4.

E-2.2.1. SW4 Position 1-2 Mode Enable. (Standard Mode 1 keeps 1-2 turned “OFF”).

E-2.2.1.1. SW4 Position 1-2 Mode Enable. 10K12 Systems.

Mode 1, SW4 1-2 all “OFF”. The 10K12 single speed system comes standard configured this way from the factory with three motion controls and six auxiliaries (controlled by the toggle switches). The 10K12 2-speed system comes standard configured this way from the factory with three 2-speed controls and three auxiliaries (controlled by the toggle switches, the rotary is non-functional).

Mode 2, SW4 1 turned “OFF” and SW4 2 turned “ON”. The 10K12 2-speed system configured this way is able to control four 2-speed motion controls and no auxiliaries (bridge, trolley, main and aux hoist). The rotary selector switch functions are H1 main hoist, H2 aux hoist and B both main and aux hoist (the toggle switches are non-functional).

Mode 3, SW4 1 and 2 turned “ON”. The 10K12 2-speed system will control up to 5 motors using the rotary selector switch. This mode reconfigures two of the 10K12 auxiliary outputs (Aux 1 and Aux 2) to be external motor select functions by the rotary switch. In this mode the auxiliary toggle switch Aux 1 and Aux 2 is disabled. When the rotary switch is in the H1 or H2 position Aux 1 relay or Aux 2 relay will pull in respectively whenever trolley or hoist

pushbuttons are pressed. When the rotary switch is in B position both Aux 1 and Aux 2 relays will pull in.

E-2.2.1.2. SW4 Position 1-2 Mode Enable. 10K16-24 Systems.

Mode 1, SW4 1-2 all “OFF”. The 10K16 3-speed system comes standard configured this way from the factory with three 3-speed controls and four auxiliaries. The 10K24 3-speed system comes standard configured this way from the factory with five 3-speed controls and four auxiliaries.

Mode 2, SW4 1 turned “ON” and SW4 2 turned “OFF”. The 10K24 configured this way gives hoist, trolley and bridge with independent select functions. The system utilizes separate select relays with common speed and direction.

Mode 3, SW4 1 turned “OFF” and SW4 2 turned “ON”. The 10K24 configured this way is four motor 3-speed selectable by the rotary switch. Two hoists, one trolley and one bridge with main hoist (H1), auxiliary hoist (H2), and “both” (B) main and auxiliary hoists are selectable by the rotary switch.

E-2.2.2. SW4 Position 3 Disable Tandem for hoist and trolley. (Normally keep turned “OFF”).

For cranes with auxiliary hoists and/or trolleys, turning this switch “ON” disables the transmitter selector switch “B” position (both function) that selects tandem operation of hoist or trolley.

E-2.2.3. SW4 Position 4 Invert Crane Select Aux. Outputs. (Normally keep turned “OFF”).

For cranes that use the select function only, turning this switch “ON” inverts the select function operation so that the relay closes for the unselected function.

E-2.2.4. SW4 Positions 5-7 Extended Crane Control.

E-2.2.4.1. SW4 Positions 5-7 Extended Crane Control for Stepped Systems. (Standard all “OFF”).

The 10K JLTX transmitter is available with extended crane control configurations. These options are switch configurable on the transmitter. The eight-position dip switches SW3

Appendix E –10K JLTX Transmitter (Continued)

and SW4 on the transmitter can provide all configurations with a single transmitter CPU EPROM for a particular transmitter style. The programming tables for the transmitter extended crane control configurations are found in the Telemotive Series 10K12/24 Radio Control system manual. In this manual three sections apply Appendix A, Table 1 for 10K12/18 systems, Appendix B, Table 1 for 10K16 systems or Appendix B, Table 2 for 10K24 systems. In these sections if the JLTX is not specifically listed use the switch programming guide for the configurations labeled SLTX.

E-2.2.4.2. SW4 Positions 5-7 Extended Crane Control for Stepless Systems. (Standard all “OFF”).

The 10K JLTX Stepless transmitter is available with extended crane control configurations. These options are switch configurable on the transmitter. The eight-position dip switches SW3 and SW4 on the transmitter can provide all configurations with a single transmitter CPU EPROM for a particular transmitter style. The programming tables for the transmitter extended crane control configurations are found in the Telemotive Series 10K12/24 Radio Control System Manual Supplement Appendix D. In these sections if the JLTX is not specifically listed use the switch programming guide for the configurations labeled SLTX.

E-3.Replacement Transmitter EPROM’s.

All 10K JLTX transmitters use CPU EPROM part numbers as listed below:

Model Number	Control Type	System	EPROM	Firmware
10K12SM02J1	Two speed	10K12	FW2880-0	FW3019-1
10K12SJ02J1	Two speed	10K12	FW2880-0	FW3019-1
10K16SM03J2	Three speed	10K16	FW2881-0	FW3020-1
10K16SJ03J2	Three speed	10K16	FW2881-0	FW3020-1
10K24SM03J1	Three speed	10K24	FW2879-0	FW3018-1
10K24SJ03J1	Three speed	10K24	FW2879-0	FW3018-1
10K24SM05J1	Five speed	10K24	FW2882-0	FW3021-1
10KS1207J2	Stepless	10K12	FW2883-0	FW3022-1
10KS1607J1	Stepless	10K16	FW2885-0	FW3024-1
10KS2407J1	Stepless	10K24	FW2884-0	FW3023-1
10KS1202J2	Stepless Hoist, 2-SPD Bridge/Trolley	10K12	FW2886-0	FW3025-1
10KS1220J2	Stepless Bridge/Trolley, 2-SPD Hoist	10K12	FW2887-0	FW3026-1
10KS1603J1	Stepless Hoist, 3-SPD Bridge/Trolley	10K16	FW2889-0	FW3028-1

Appendix E – 10K JLTX Transmitter (Continued)

E-4.10K JLTX Transmitter Board Setup Information.

The 10K JLTX Transmitter Board is shown in Figure E-2. Refer to paragraphs E.4.1 through E-4.8 for setups.

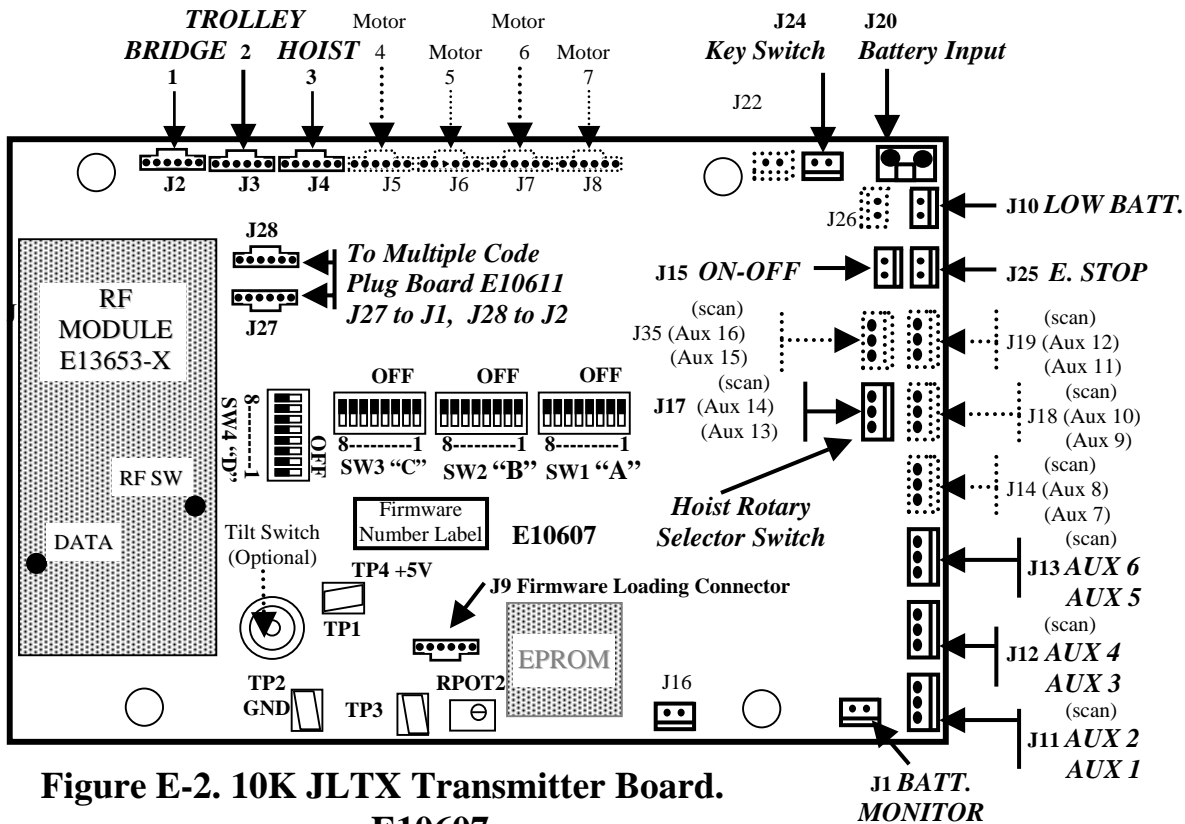

**Figure E-2. 10K JLTX Transmitter Board.
E10607**

E-4.1. Cable Connections.

For re-cabling the unit the bold italicized labels above in Figure E-2 correspond to the connection points for controls, inputs and indicators. Plug appropriate controls, inputs and indicators into their corresponding labeled connectors.

E-4.2. Setting Access Code.

The access code is set at the factory and should not be changed unless absolutely necessary. If a spare transmitter unit is used, the receiver unit access code should be changed to match the access code of the spare transmitter unit. Access codes are printed on a white label on the outside of any transmitter and may be matched to "A" and "B" on the receiver microcomputer module without having to open the transmitter housing.

Switch SW2 (B) in the transmitter must match switch S4 (B) on the receiver microcomputer module and switch SW1 (A) in the transmitter must match switch S5 (A) on the microcomputer module.

E-4.2. To Check Data.

- 1). For data input use Data pin on RF Module.
- 2). Use RF SW pin on RF Module for External Trigger input.
- 3). Use TP2 for Ground.

E-4.3. Battery Monitor.

Factory reset to 5.8 Volts not adjustable.

E-4.4. Analog Voltage Reference.

Controls lever and joystick range. V+ (TP3) factory adjusted with RPOT3.

Appendix E –10K JLTX Transmitter (Continued)

E-5. Batteries.

Two batteries are available, a disposable alkaline battery BT107-0 and a rechargeable NiMH BT108-0. The single unit charger for the BT108-0 is E10674-0. Please follow local regulations for the disposal of any battery product.

The “LOW BATT” red LED will flash briefly just before transmitter shuts down due to low battery. If this light flashes, then replace the battery immediately. The flashing red “BATT MONITOR” LED flashes rapidly during transmit, slowly when unit is ON and turns out when battery is low.

E-6. Intrinsically Safe.

Certain models of the JLTX are intrinsically safe and these are clearly marked so on the bottom of the case. To maintain the intrinsically safe rating an intrinsically safe battery must be used. Intrinsically safe batteries are labeled intrinsically safe. Connect your Telemotive representative for the part number of the intrinsically safe battery for your transmitter.

**WARNING**

FOR INTRINSICALLY SAFE PRODUCTS ONLY QUALIFIED TRAINED SERVICE PERSONNEL ARE ALLOWED TO PERFORM REPAIRS. FAILURE TO USE APPROVED SERVICING TECHNIQUES AS WELL AS TELEMOTIVE APPROVED PARTS FOR INTRINSICALLY SAFE PRODUCTS COULD CREATE A SAFETY HAZARD. IF THERE IS ANY QUESTION AS TO WHOM IS QUALIFIED, WHAT PARTS TO USE OR PROPER SERVICE PROCEDURES PLEASE CONTACT YOUR TELEMOTIVE REPRESENTATIVE. FAILURE TO FOLLOW THIS WARNING COULD RESULT IN SERIOUS INJURY OR DEATH AND DAMAGE TO EQUIPMENT.

E-7. Replacement Parts.

The following pictures on pages E-7, through E-9 detail replacement parts for the JLTX.

**WARNING**

FOR PRODUCT MODELS LISTED IN COMPLIANCE WITH UL, CSA AND ANSI INTRINSICALLY SAFE STANDARDS, DO NOT ATTEMPT TO REPAIR WITHOUT USING TELEMOTIVE APPROVED REPLACEMENT PARTS. FAILURE TO DO SO COULD VOID LISTING AND CREATE A SAFETY HAZARD. FAILURE TO FOLLOW THIS WARNING COULD RESULT IN SERIOUS INJURY OR DEATH AND DAMAGE TO EQUIPMENT.

E-8. Joystick and Levers.

Please note should the lever and joysticks need servicing, please contact Telemotive.. These are environmentally sealed switches, tested for millions of cycles and should not need replacement under normal conditions.

**WARNING**

DISASSEMBLING THE JOYSTICK OR THE LEVER WITHOUT PROPER TRAINING AND EQUIPMENT COULD DESTROY THE SEAL AND DAMAGE THE SWITCH CAUSING IMPROPER OPERATION. FAILURE TO FOLLOW THIS WARNING COULD RESULT IN SERIOUS INJURY OR DEATH AND DAMAGE TO EQUIPMENT.

E-9. JLTX Transmitter Firmware.

EPROMs are not used in the JLTX Transmitter Board Rev. F and higher; firmware (software) is stored internally in non-volatile flash memory. Software updates are done in the factory through the firmware loading connector. A firmware version label on the board indicates the software version loaded into flash memory.

Appendix E – 10K JLTX Transmitter (Continued)

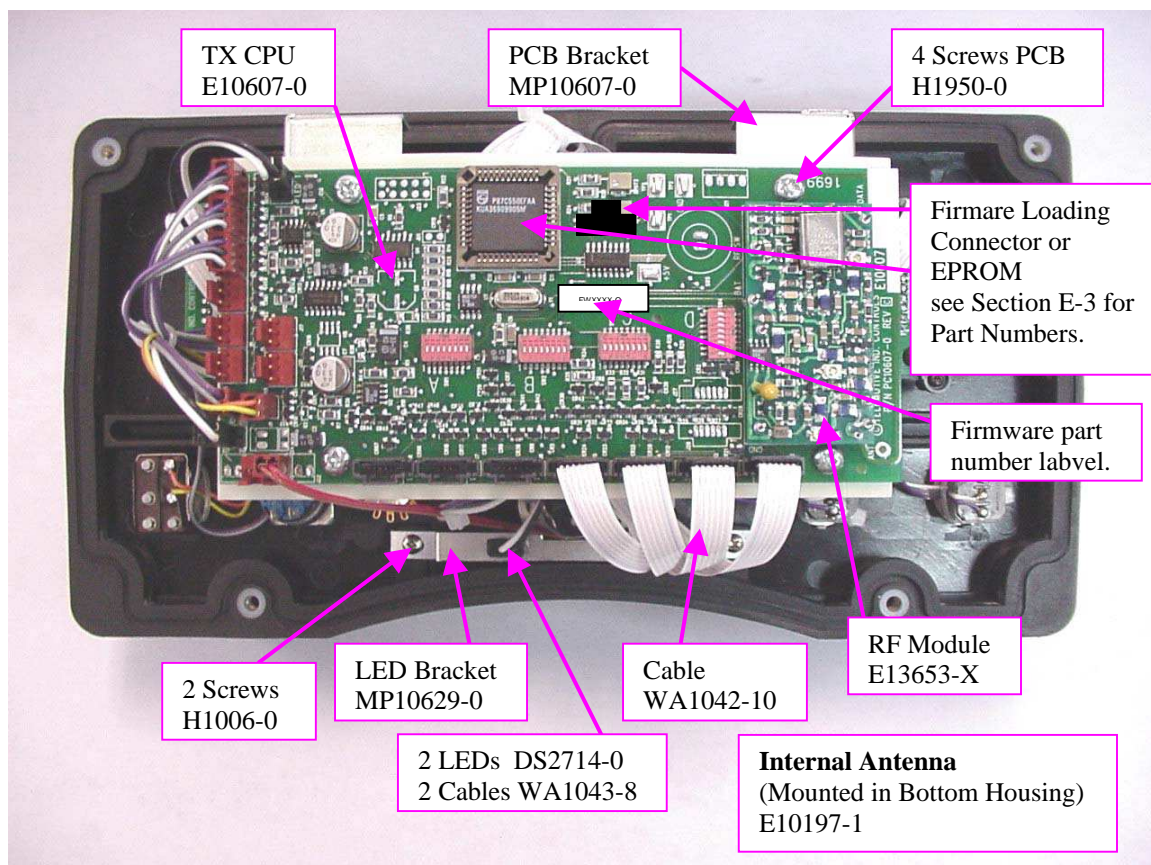
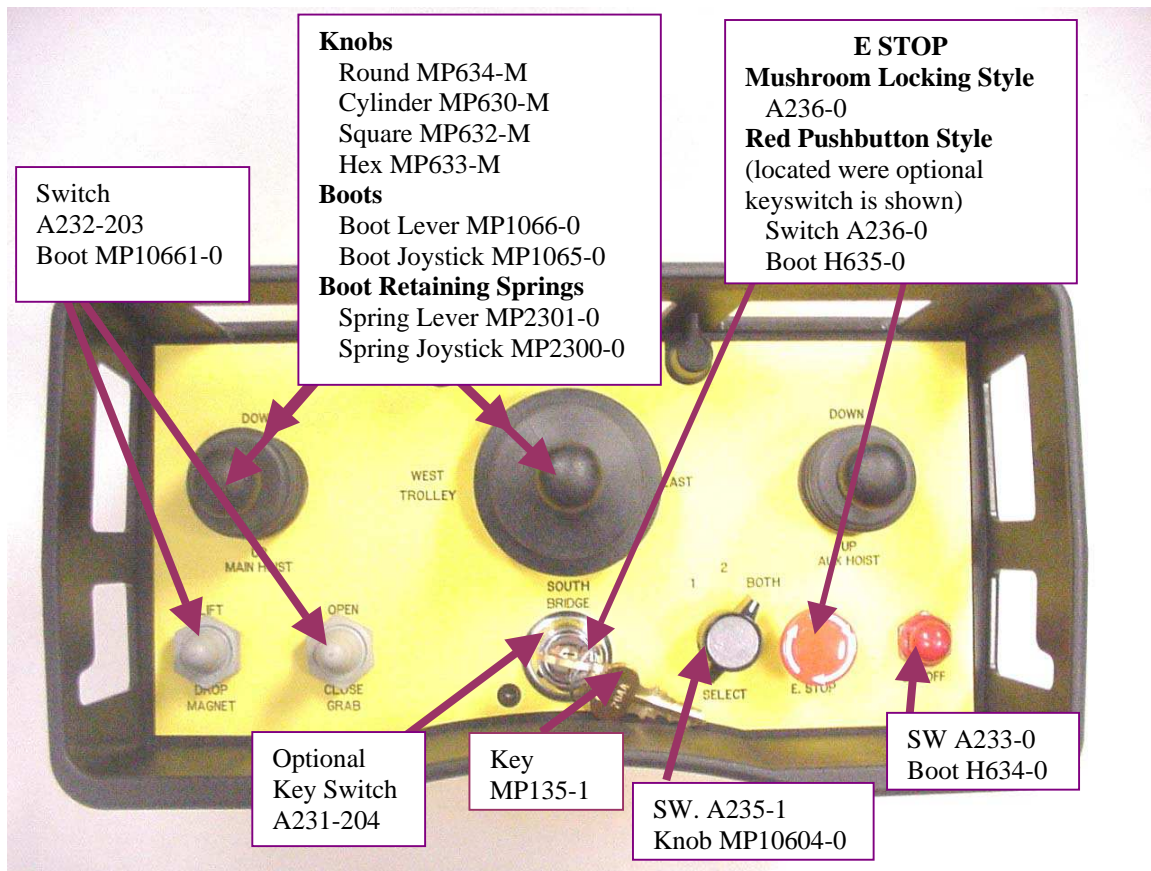

Appendix E – 10K JLTX Transmitter (Continued)

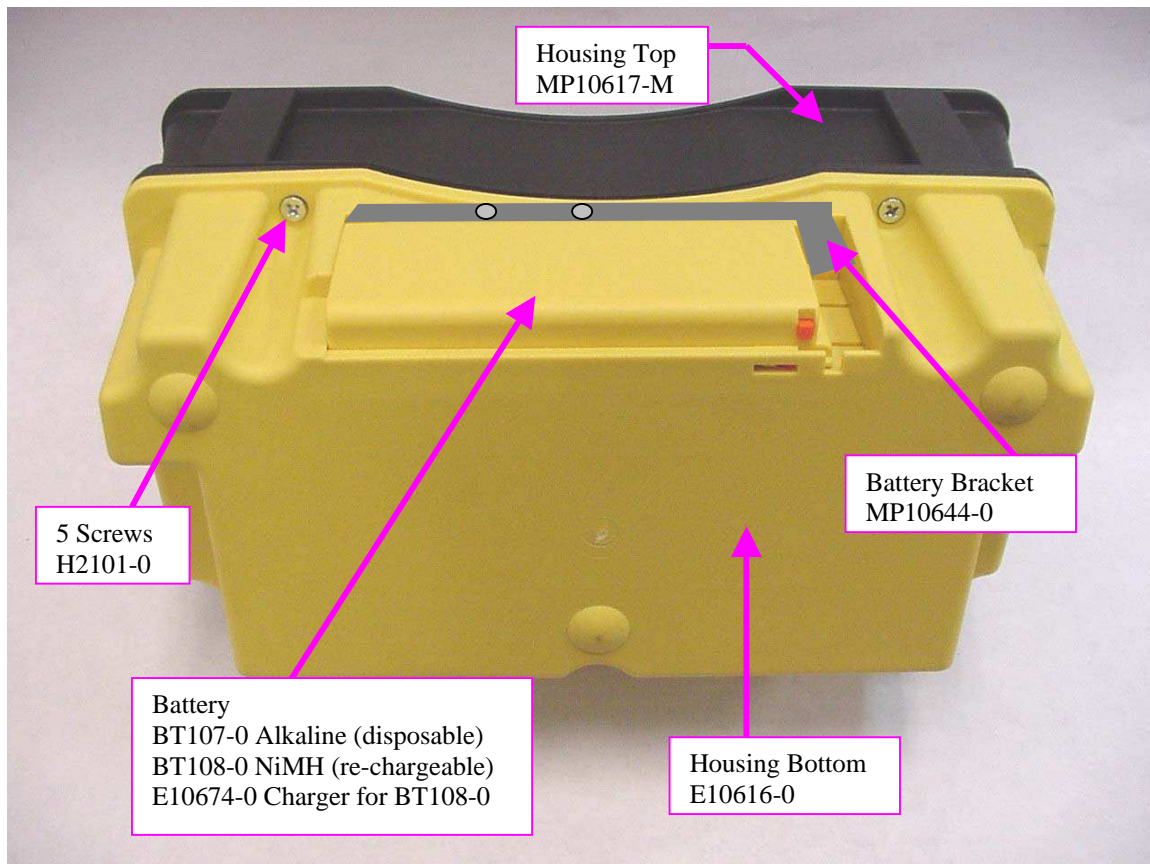
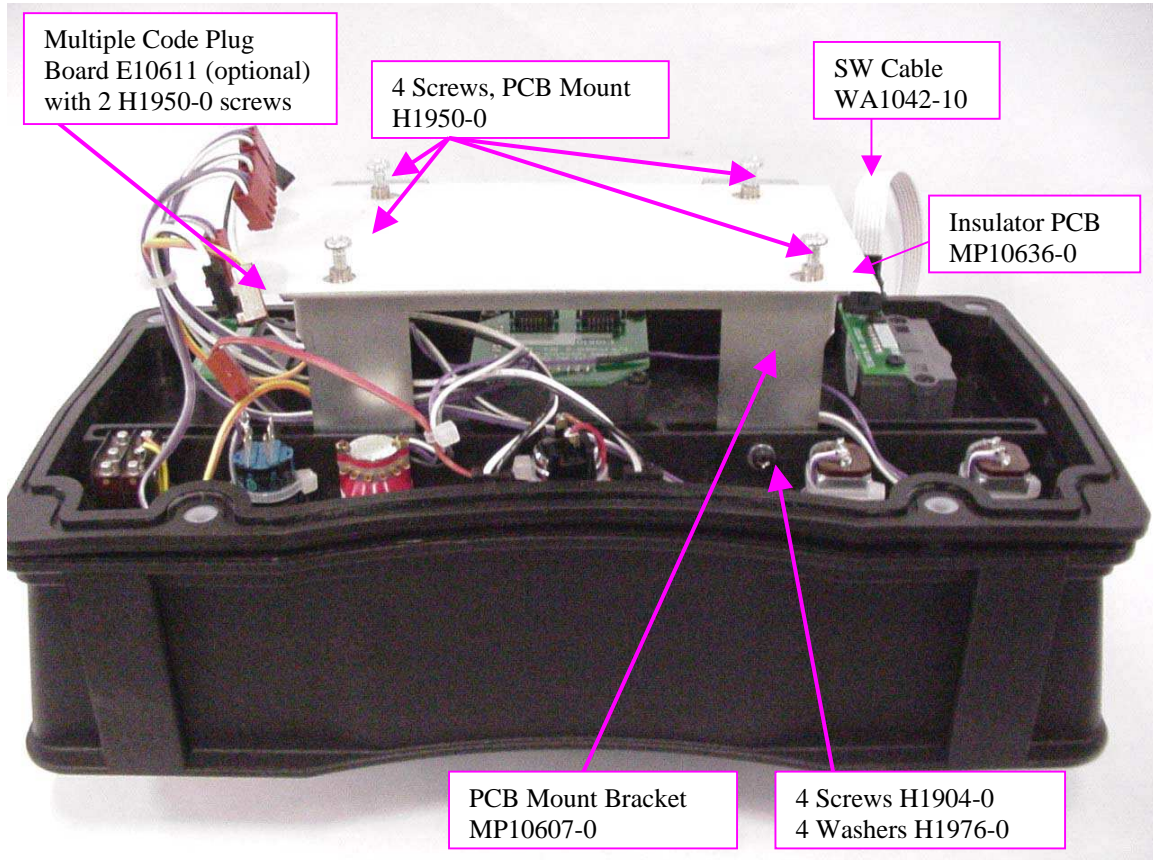

Appendix E –10K JLTX Transmitter (Continued)



MP10619-0
Waist Belt

MP10620-0
Neck Strap