

**SUPPLEMENTAL INSTRUCTION SHEET
FOR 10KM12
WITH FW2832-1 EPROM IN RECEIVER CPU BOARD**

The new FW2832-1 software performs identical to the previous versions of software available for the 12KM12, but also has added features listed below. These features are activated by turning ON certain switches on the receiver CPU board. Please check the number label on the EPROM to make sure it has this number before attempting to use these added features. If not, it must be replaced with the appropriate EPROM. When replacing the EPROM please note the orientation of the EPROM. See the picture below for location and orientation of the EPROM.

SW2 position 4 when turned ON gives a Special DeMag configuration with **all the transmitter configurations all turned OFF** (positions 5-7). Please check the diagram on the next page for Special DeMag relay sequencing. See the picture below for location of SW2 position 4.

SW3 position 5 when turned ON gives Active ESTOP. **This feature can only be used with transmitters so equipped.** Please check with Telemotive to determine the appropriate transmitter. See the picture below for location of SW3 position 5.

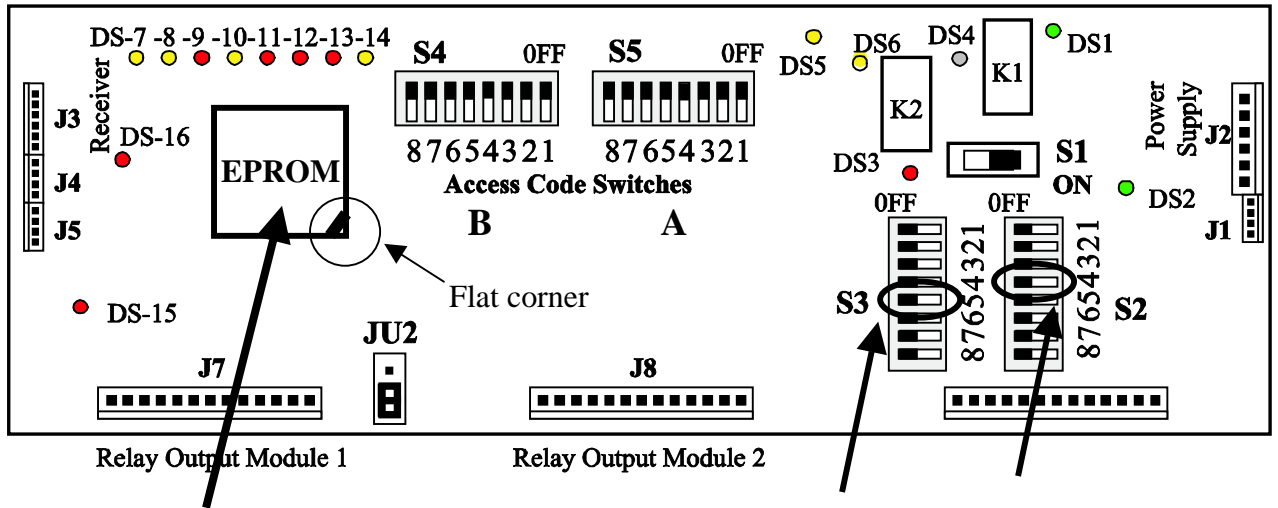

FW2832-1 EPROM
PLEASE NOTE THE FLAT
CORNER ON THE
LOWER RIGHT HAND
SIDE WHEN INSERTING.

RECEIVER CPU BOARD

TABLE 2(SPECIAL A) DEMAG 2-SPEED PROGRAMMING DIAGRAM.

**(SPECIAL: OPENING HOIST DIRECTIONAL ON SECOND SPEED):
2-SPEED, 2-WINDINGS for HOIST;
STANDARD TROLLEY and BRIDGE**

Note

Must be used with software FW2832-1, see page 1.

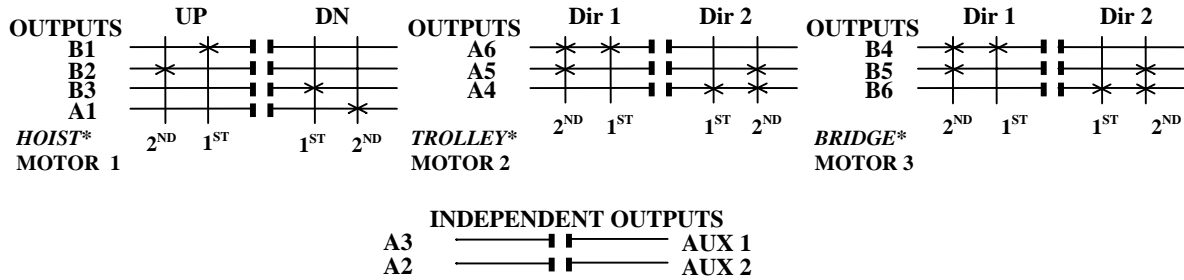

MOTOR 1 CONNECTIONS

- B1 HOIST UP
- B2 HOIST UP 2ND SPEED
- B3 HOIST DOWN
- A1 HOIST DOWN 2ND SPEED

MOTOR 2 CONNECTIONS

- A6 TROLLEY DIR 1
- A5 TROLLEY 2ND SPEED
- A4 TROLLEY DIR 2

MOTOR 3 CONNECTIONS

- B4 BRIDGE DIR 1
- B5 BRIDGE 2ND SPEED
- B6 BRIDGE DIR 2

INDEPENDENT CONNECTIONS

- A3 AUX 1 (LATCHABLE S2-7)
- A2 AUX 2 (LATCHABLE S2-6)

TRANSMITTER SWITCH SETTINGS

telePilot or telePendant USE PDA SCREEN (Program the configuration switches 5, 6 & 7 to match the settings shown below).

MEMBRANE USE SW3 “C”

PENDANT, JLTx AND SLTx USE SW4 “D”

TRANSMITTER SWITCH SETTINGS:

- Position-5 OFF**
- Position -6 OFF**
- Position -7 OFF**

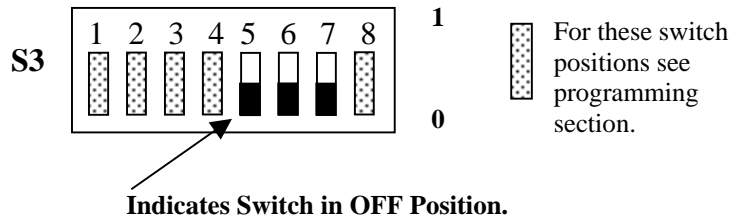

*NOTE: Hoist, Trolley and Bridge are listed here as traditional configurations, the installer may choose to define the motors differently.