

INSTALLATION AND USERS MANUAL

TELEMOTIVE APPENDIX D 10KM SERIES STEPLESS

RADIO

CONTROL

SYSTEM



MAGNETEK
UNCOMMON POWER

Material Handling Group

N49 W13650 Campbell Drive
Menomonee Falls, WI 53051
Phone: 800-288-8178 Fax: 262-783-3510
Website: www.telemotive.com

This page intentionally left blank

Table of Contents

1-	Service Information.....	1
2-	Installation Information.....	2
3-	Operation and Setup.....	9
4-	Optional Wiring Tables.....	20
5-	Firmware.....	61

Section 1 – Service Information

1-1. Service Information.

For questions regarding service or technical information, contact the Telemotive Field Service Department.

For ordering replacement parts contact the Telemotive Order Entry Department.

Magnetek Material Handling Group
N49 W13650 Campbell Drive
Menomonee Falls, WI 53051

Telephone: 800-288-8178

Website: www.telemotive.com

Email: info@telemotive.com

Fax Number

Main: 800-298-3503

Sales: 262-783-3510

Service: 262-783-3508

Section 2 – Installation Information



WARNING

BEFORE USING THIS SUPPLEMENT PLEASE FAMILIARIZE YOURSELF WITH THE CRANE SAFETY REQUIREMENTS IN MANUAL TC10K12M. ALSO REVIEW ALL LOCAL AND GOVERNMENTAL REGULATIONS. FOR ADDITIONAL OPERATIONAL, INSTALLATION AND SERVICING INFORMATION SEE THE ABOVE MANUAL. FAILURE TO FOLLOW THIS WARNING COULD RESULT IN SERIOUS INJURY OR DEATH AND DAMAGE TO EQUIPMENT.

D-2-1. Pre-Installation Considerations.

To ensure reliable and safe operation of the system, the following items must be considered before installing the receiver unit.

If the receiver unit is installed outdoors or in a corrosive environment, the receiver unit cabinet must be housed in a protective enclosure.



WARNING

NO MORE THAN 4 UNITS ON THE SAME FREQUENCY SHOULD BE MOUNTED WITHIN 600 FEET OF EACH OTHER. FAILURE TO FOLLOW THIS WARNING COULD RESULT IN SERIOUS INJURY OR DEATH AND DAMAGE TO EQUIPMENT.



WARNING

THE RECEIVER UNIT OR RELAYS ARE NOT RATED AS EXPLOSION PROOF. THE RECEIVER UNIT MUST NOT BE INSTALLED IN EXPLOSIVE ENVIRONMENTS UNLESS APPROPRIATE SECONDARY ENCLOSURE MEASURES ARE TAKEN. FAILURE TO FOLLOW THIS WARNING COULD RESULT IN SERIOUS INJURY OR DEATH AND DAMAGE TO EQUIPMENT.

The receiver unit should not be subjected to moisture.

D-2-2. Receiver Unit Mounting Location Considerations.

Ensure the mounting location is as far as possible from exposed trolley wires and sources of electromagnetic or radiated noise.

If possible, avoid installing receiver unit to a surface where high vibration or shock is present. If this cannot be avoided, use appropriate shock mounts.

Ensure mounting location is as far as possible from exposed Trolley wire and sources of electromagnetic or radiated noise.

D-2-3. Line Input Considerations.



WARNING

THE UNIT MUST BE WIRED TO THE CORRECT VOLTAGE. FAILURE TO FOLLOW THIS WARNING COULD RESULT IN SERIOUS INJURY OR DEATH AND DAMAGE TO EQUIPMENT.

The receiver unit has direct and separate connect provisions for operation from 120 or 240 VAC (nominal), 50-60 Hz power.

For applications where line voltage deviation exceeds 20% of nominal values or if 440 VAC power is used, a step up or step down transformer must be used.

NOTE

THE RECEIVER UNIT SHOULD NOT BE CONNECTED TO LINES CONTAINING EXCESSIVE POWER UP TRANSIENTS OR

Section 2 – Installation Information (Continued)

CONTINUOUS COMMUTATOR NOISE. A LINE CONDITIONER MAY BE NECESSARY IN SOME INSTALLATIONS.

D-2-4. Wiring Considerations

1. Read this manual before installation.
2. Please observe National Electric Code (NEC) when wiring electrical devices.
3. Do not connect or disconnect wiring, or perform circuit checks while the power is turned on.
4. The motor wiring should be in a separate metal conduit from the power wiring, which should also be in metal conduit.
5. Low voltage wires shall be wired with Class 1 wiring.
6. Control wiring as well as antenna wiring shall be in separate conduit and shall be kept as short as possible.
7. All terminals shall be tightened to specified terminal torque (4.4 IN-LBS. unless otherwise specified).
8. Remove excess metal screws, metal filings and wire clippings from inside of unit.
9. Inspect to make sure no exposed wire has contact with any other wiring or terminals.
10. Suppressors are strongly recommended on all contactors.

D-2-5. Receiver Cabinet Mounting.

Recommended mounting hardware is four - 1/4-20 hex machine screws of appropriate length, four 1/4-20 x 7/16 "keps" or elastic stop nuts.

Flat washers should be used in front of nuts when receiver unit is mounted to a non-structural surface.

Mount receiver unit cabinet securely to mounting surface.

D-2-6. EZ Setup.

1. Determine the type of transmitter you have with your unit. JLTX, or pendant. Select the

wiring configuration that matches your application.

2. Refer to the transmitter switch-programming table at the bottom of the page for the selected configuration.
3. If necessary, open the transmitter and set the switches as shown in the configuration diagram. Normally your unit is pre-programmed at the factory and only installation is necessary. The programming information for the transmitter and receiver is only needed for systems purchased un-programmed or to change system programming. Switch locations are in. **DO NOT CHANGE SWITCH SW1 OR SW2.** These switches program the access code and must be programmed to match the receiver. After setting these switches reassemble the transmitter. Make sure fully charged batteries are placed in the unit.
4. Determine if you need to special program the receiver. **NORMALLY YOU WILL NOT NEED TO CHANGE RECEIVER SWITCH SETTINGS.** Change the receiver settings only to add latched functions, multi box or alarm settings. For information on these settings see the appropriate configuration page.

D-2-7. Receiver Installation.

1. Mounting area, approximately 14" wide by 18" long.
2. Ensure mounting location is as far as possible from exposed Trolley wire and sources of electromagnetic or radiated noise. Antenna should be pointed straight up.
3. Mount unit and install antenna.
4. Set switch SW1 on power supply to off position towards right of cabinet. Set switch SW1 on computer module to the left to disable radio outputs.
5. Connect power leads to right lower terminal strip J1 on power supply board to either 120 VAC and ground or 240 VAC and ground.

Section 2 – Installation Information (Continued)

6. Use, or and pick a wiring diagram on pages 12 through 18 that fits the appropriate interface. All control wiring for the interface should be connected at terminals to J2 on relay output board. When using more than one control transformer the jumpers on J3 must be removed (if provided) and J3 should be wired for the proper voltage per terminal.
7. In the lower right side of the receiver cabinet on the power supply board you will find relay K1 (MR). Terminals 2 and 4 are used to control any master relay function of the control. Relay K1 is shown in the wiring diagrams in , and .
8. Wiring of the 10K system should now be complete.
9. Apply power.
10. Check out radio functions with the outputs disabled. Light DS3 should be out at this time. After the check, put S1 back to the on position DS3 should light. Check function and direction by jogging each motion. Installation should now be complete.

D-2-8. Master Control Relay (MCR) Enable. (S1)

This switch, when turned to off, disables the MCR and removes all output power to all output relays. This allows testing of the receiver control circuitry without activating any external functions such as motors and horns.

D-2-9. Auxiliary Functions General.

The 10K receivers have auxiliary (Aux) function capability. These Aux functions are dedicated relays that can be used to sound horns, light lights or other functions. Typically a 10K12 has 3 Aux functions and a 10K16/24 has 4. However, there are a number of specialties and variations available. If your transmitter does not have a document describing these functions, the easiest way to determine what the Aux functions do is to look at the relay control boards and while depressing the appropriate Aux switch on the transmitter see which LED lights for which relay.



WARNING

MAKE SURE S1 MASTER CONTROL RELAY (MCR) IS TURNED OFF BEFORE ATTEMPTING THIS TO PREVENT ACTIVATION OF EXTERNAL CIRCUITRY. FAILURE TO FOLLOW THIS WARNING COULD RESULT IN SERIOUS INJURY OR DEATH AND DAMAGE TO EQUIPMENT.

D-2-10. System Functions Selection.

Special programming exists to allow some of the Aux relays to be dedicated for special system functions. Setting certain dip switches on the CPU Board enables this programming.

1. Auto Alarm (S2-1).

Description: Gives about 5 seconds of alarm when the transmitter is first turned on. You can have Auto Alarm and EMS Alarm or both. The use of either one of these two functions dedicates one specific control relay to operate an external alarm. An external alarm (not supplied) needs to be connected to this relay.

To Enable: Connect an external alarm. Move dip switch S2-1 on the CPU Board to the ON position.

2. Emergency Stop (EMS) Alarm (S2-2).

Description: Gives about 5 seconds of alarm when the Emergency Stop (EMS) is activated on the transmitter. You can have Auto Alarm and EMS Alarm or both. The use of either one of these two functions dedicates one specific control relay to operate an external alarm. An external alarm (not supplied) needs to be connected to this relay.

To Enable: Connect an external alarm. Move dip switch S2-2 on the CPU Board to the ON position and set jumper JU2 to the upper position. (As a safety measure during EMS shutdown all control lines to relays are disabled. Jumper JU2 facilitates bypassing the EMS shutdown to the Alarm Relay so it can be activated during an EMS shutdown.) See the appropriate page for switch and jumper details and for location of the Alarm Relay.

Section 2 – Installation Information (Continued)

3. Master Control Relay (MCR) Monitoring Disable (S2-3).

Description: Disables the contact monitoring of the MCR. Used for special diagnostic purposes only.

Enable: In normal operation switch S2-3 should be set to OFF. Set to ON to disable contact monitoring of MCR.

4. Auxiliary Function Relay Latching (S2-6, -7 and -8).

Description: Enables the appropriate auxiliary function relay to operate in a latched mode, on or off, rather than as a momentary contact. Which function is latchable and which relay is latched depends on the particular transmitter used.

Enable: Switch S2, positions 6 through 8 on the CPU Board each enable a separate relay to be latched when turned on. If your transmitter does not have a document describing these functions, the easiest way to determine correlation of transmitter function, relay position and dip switch position, is to try various dip switch setting and see which relays are latched and which transmitter controls them. Make sure all three switch positions are off, turn S2-6, S2-7 and S2-8 on separately and note which relay is affected by the appropriate LED indication.

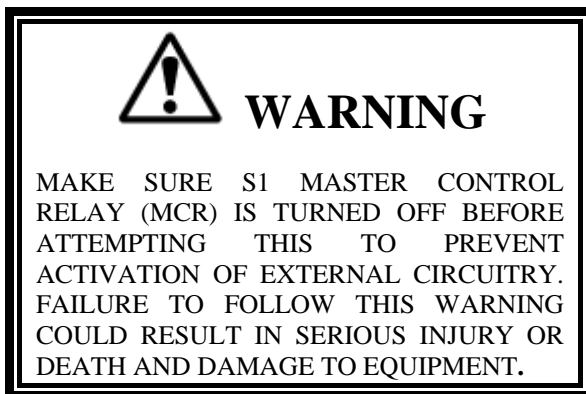

5. Time Out Timer Enable (S3-2).

Description: The receiver contains a time out timer. If a receiver once turned on by a transmitter does not receive a signal from a transmitter for a period of 15 minutes the receiver shuts down.

Enable: Setting S3-2 to ON disables this function.

6. Multibox Enable (S3-3).

Description: One transmitter can only control the 10K receiver with a specific access code at a time. However, Multibox capability allows the 10K receiver to automatically switch to a new transmitter when the current controlling transmitter has been turned off and a new transmitter turned on. Up to 4 different transmitters can control one receiver.

Enable: To enable this function the receiver must be preprogrammed from the factory for Multibox; the appropriate Multibox dip switch enabled (S3-3) and the correct access codes must be programmed into the appropriate transmitters. (Note: access codes are factory programmed into the receiver and the access codes are sequential.). Switch S3-3, when turned on, enables Multibox. Turning off S3-3 in 10K receiver pre-programmed from the factory for Multibox disables this function. S3-3 has no function in a receiver that is not pre-programmed by the factory for Multibox.

NOTE

FOR INFORMATION ON INTERFACING WITH SYSTEMS WITH HIGH IMPEDANCE INPUTS SEE THE FOLLOWING SECTION. CONNECTING OUTPUTS TO DRIVES OR CONTACT TELEMOTIVE.

D-2-11. Connecting Outputs to Drives.

MOV's (transient protectors) are on all the output relays to protect the relays from power surges. MOV's allow a small leakage current that can affect some high impedance circuits. When connecting output relays to drives it may be required to remove the MOV to prevent the leakage current through the MOV from holding in the drive. The MOV's are numbered correspondingly to the relays they protect. The MOV's can be cut out of the circuit with a wire cutter. Remember to do this with ALL power off on the crane equipment and all associated controls.

Section 2 – Installation Information (Continued)

Figure D-1. Stepless 10K Wiring Layout.

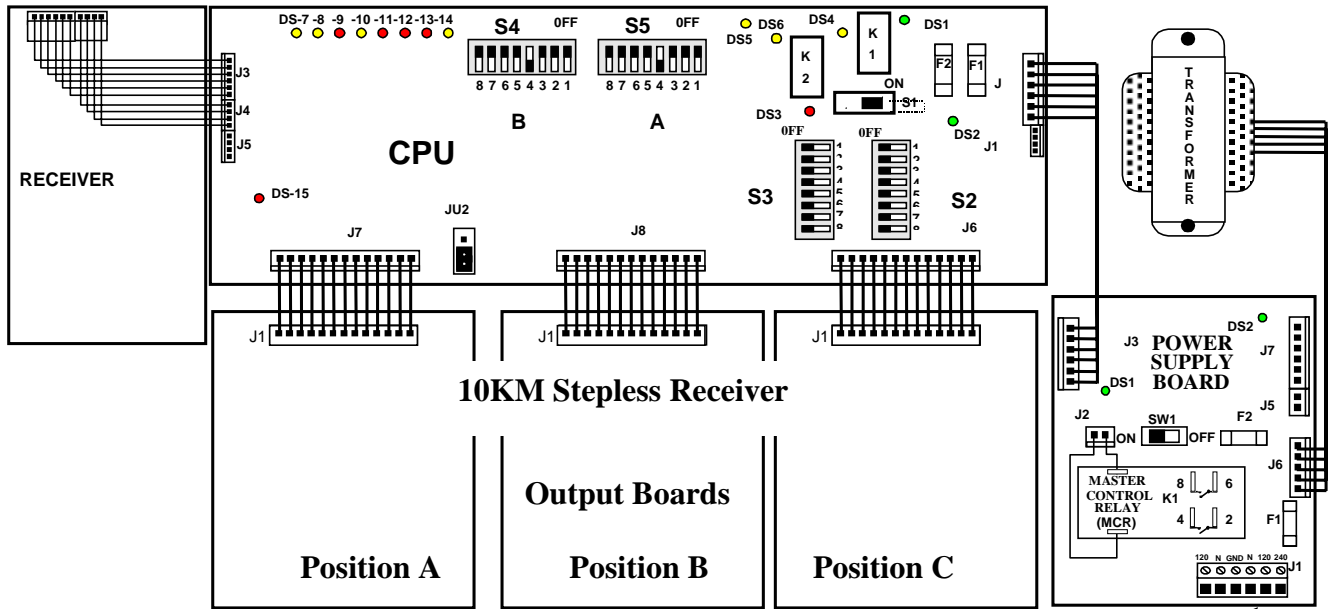

Wiring per Position A, B and C detailed by model number in the following sections.

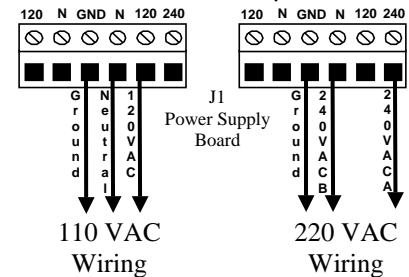

One of the boards below will be used in each of the positions A, B and C.

E10165-0 Relay Output Board
All 6 Normally Open Relays

or

E10112-0 Relay Output Board
All 8 Normally Open Relays

E10109-3 Mechanical
E10109-1 Solid State

E10116-3 Mechanical
E10116-0 Solid State

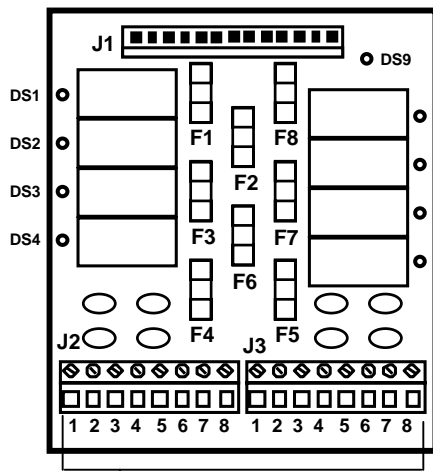

6 or 8 Normally Open Relays Paired:
 J2-1 to J3-1 J2-5 to J3-5
 J2-2 to J3-2 J2-6 to J3-6
 J2-3 to J3-3 for Eight Relays:
 J2-4 to J3-4 J2-7 to J3-7
 J2-8 to J3-8

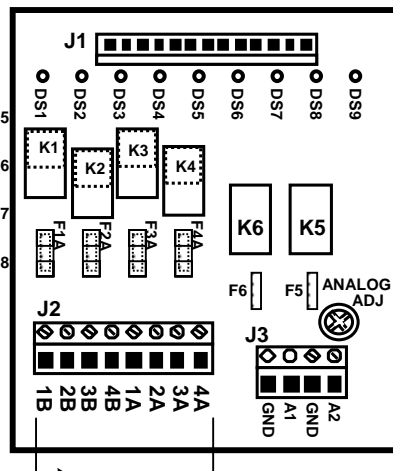

Directional relays
 1A-1B
 2A-2B
 3A-3B
 4A-4B

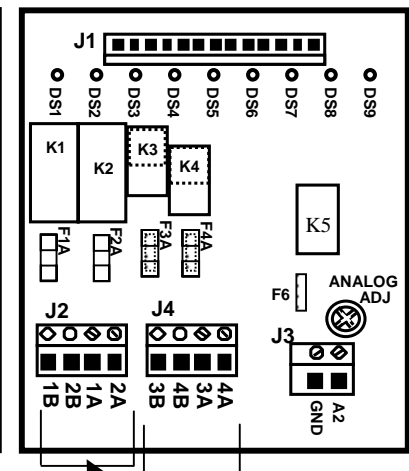

Directional relays
 3A-3B
 4A-4B
 Auxiliary relays
 1A-1B
 2A-2B

Section 2 – Installation Information (Continued)

Figure D-2. Stepless Pendant Configurations

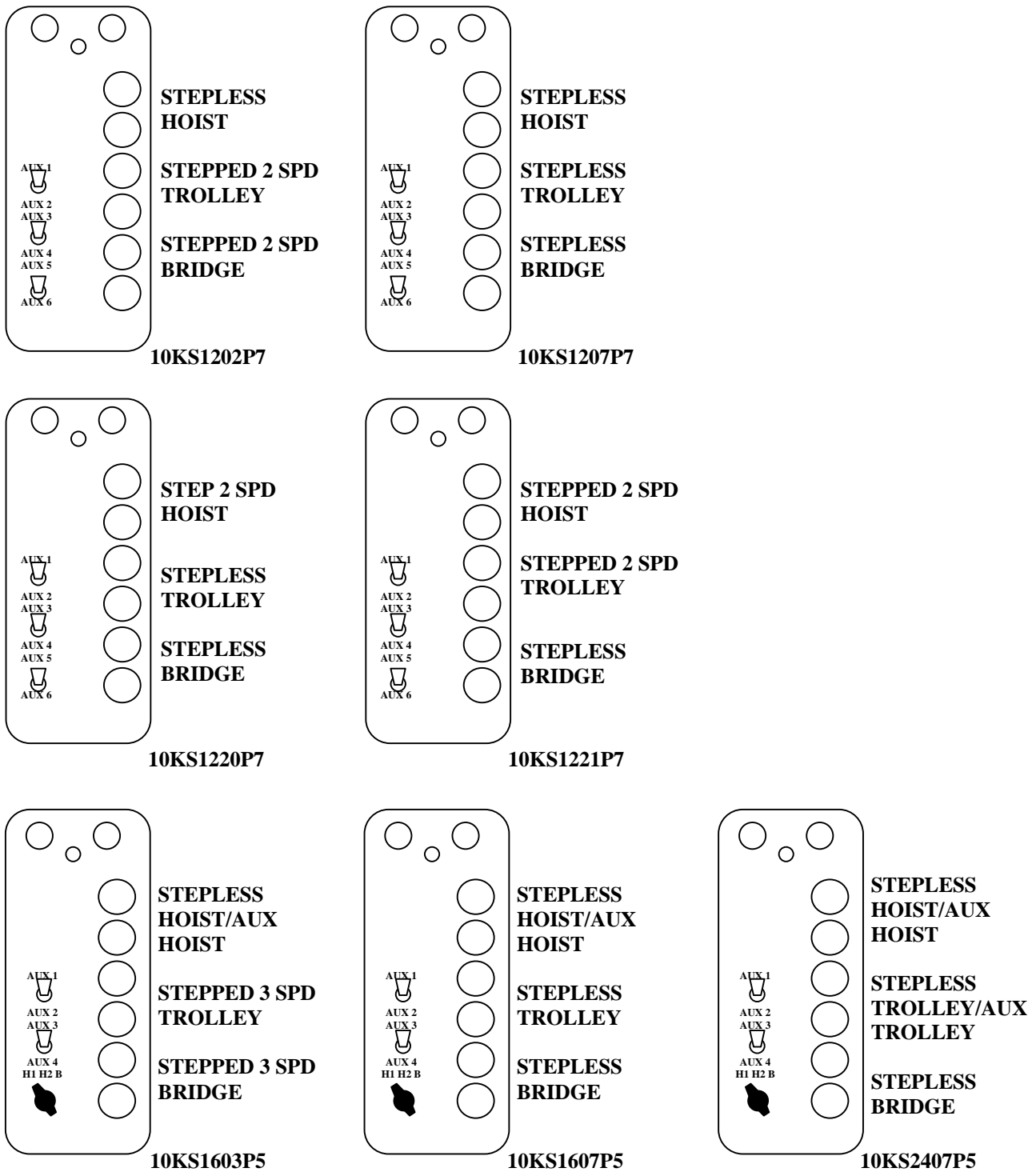

The above model numbers are transmitter only.

Add the suffix H2 for a complete system with relay directional outputs.

Or add M2 to the above model number for special systems requiring solid-state directional relays.

Section 2 – Installation Information (Continued)

Figure D-3. Stepless JLTX Configurations.

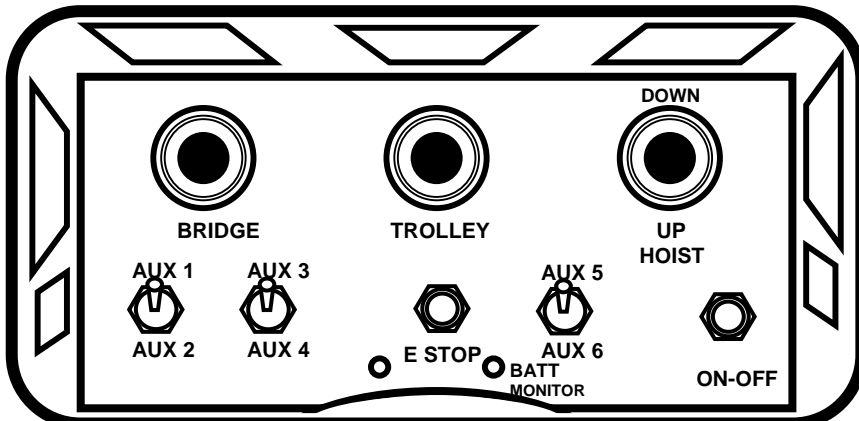

3 – Lever, 3 MOTOR, 6 AUX's
 10KLS1202J2 STPL HOIST, 2-SPD B/T
 10KLS1207J2 ALL STEPLESS
 10KLS1220J2 STPL B/T, 2-SPD HOIST

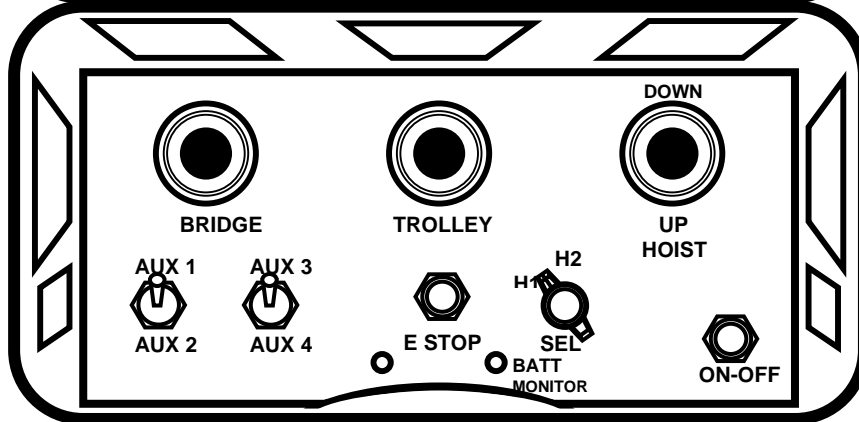

3 – Lever, 4 MOTOR, 4 AUX's
 10KLS1607J1 ALL STEPLESS
 10KLS1603J1 STPL HOIST, 3-SPD B/T

3 – Lever, 5 MOTOR, 2 AUX's
 10KLS2407J1 ALL STEPLESS

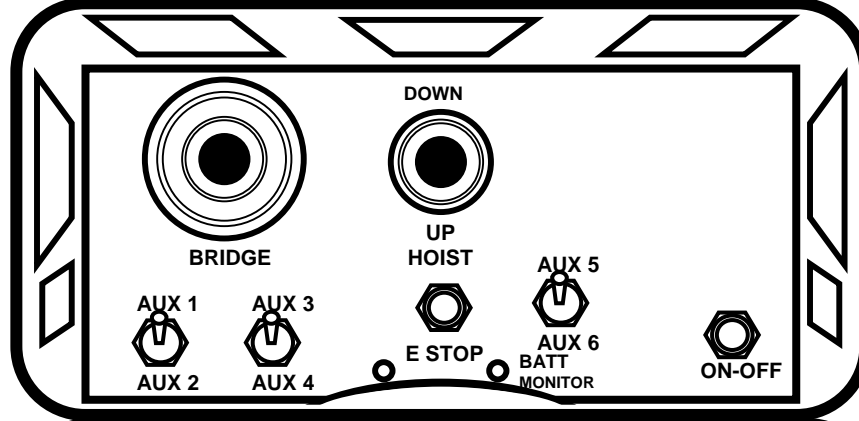

1 Joystick, 1 – Lever, 3 MOTOR, 6 AUX's
 10KS1202J2 STPL HOIST, 2-SPD B/T
 10KS1207J2 ALL STEPLESS
 10KS1220J2 STPL B/T, 2-SPD HOIST
 10KS1221J2 STPL BRIDGE, 2-SPD H/T

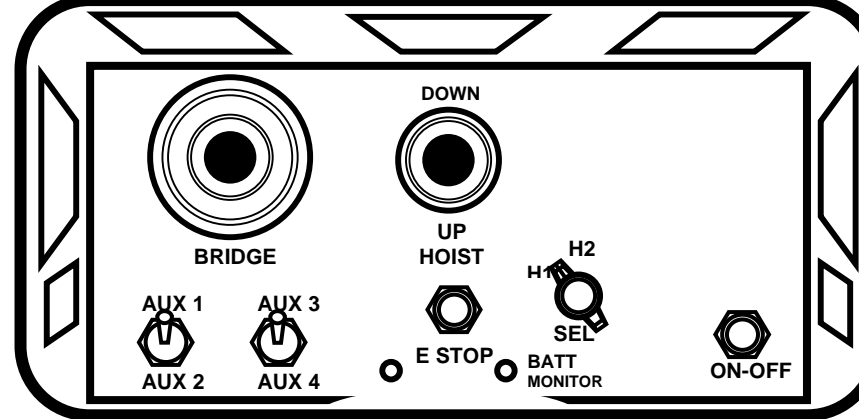

1 Joystick, 1 – Lever, 4 MOTOR, 4 AUX's
 10KS1603J1 STPL HOIST, 3-SPD B/T
 10KS1607J1 ALL STEPLESS

1 Joystick, 1 – Lever, 5 MOTOR, 2 AUX's
 10KS2407J1 ALL STEPLESS

Section 3 – Operation and Setup

D-3-1. 18K Stepless Output Board Setup Information.

The 18K Stepless Output Boards are shown in Figure D-3. Refer to paragraphs D-3-1. through D-3-7. for servicing procedures.

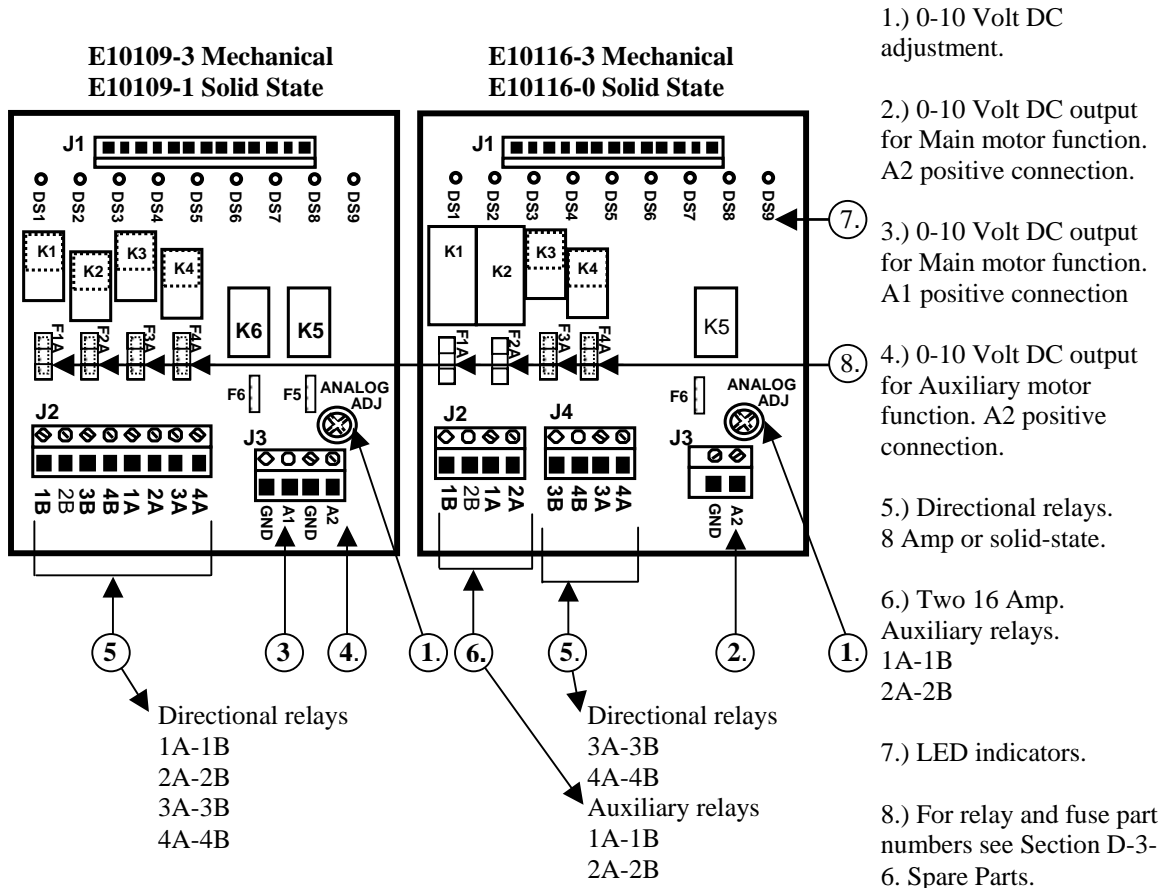

**Figure D-4. Stepless Output Boards.
E10109-X and E10116-X**

D-3-2. Operation.

The Stepless Output Board(s) was designed to interface directly into VFD's. The output consists of a continuously variable DC voltage from 0 to 10 volts plus two directional relays per motor. The directional relays are rated for 8 Amps DC maximum: E10109-3 and E10116-3. (Low current solid-state directional relays are also available for solid-state logic only switching: E10109-1 and E10116-0). For crane motor functions such as Main and Aux. Trolley or Main and Aux. Hoist, a second variable DC voltage from 0 to 10 volts plus 2 two additional

directional relay outputs are available on the two motor board.

NOTE

THE 0-10 VDC OUTPUTS ON ANY ONE STEPLESS BOARD ARE NOT INDEPENDENT. THEY ARE TO BE USED IN TANDEM WITH THE MAIN AND AUXILIARY SELECTOR SWITCH ON THE TRANSMITTER.

The auxiliary relays are rated for 16 Amps DC maximum and fused for 10 Amps continuous service.

Section 3 – Operation and Setup (Continued)

D-3-3. Indicators.

The LED indicators on the board indicate the following:

DS1 – Red - Power to relay K1A.

DS2 – Red - Power to relay K2A.

DS3 – Red - Power to relay K3A.

DS4 – Red - Power to relay K4A.

(Ground is switched to the relay coils K1A-K4A to turn them ON which also turns ON the respective LED). DS5 to DS8 – Red - These LEDs light in an increasing binary pattern to indicate increasing voltage output.

DS9 – Yellow - Power to Stepless Board.

D-3-4. Wiring.

Disable the Master Relay before servicing. See Section D-4 for detailed wiring specifics.



CAUTION

ALL CONTROL WIRES SHOULD BE RUN THROUGH SEPARATE CONDUIT. ALL ANALOG SIGNAL CONTROL WIRES SUCH AS THE ANALOG SIGNALS OUT OF THIS BOARD SHOULD BE RUN THROUGH SEPARATE CONDUIT AND MUST BE SHIELDED TWISTED PAIR. TRY TO KEEP CONTROL WIRING AS SHORT AS POSSIBLE. PLEASE OBSERVE NATIONAL ELECTRIC CODE (NEC) WHEN WIRING DEVICES. FAILURE TO FOLLOW THIS CAUTION COULD RESULT IN DAMAGE TO, OR DESTRUCTION OF EQUIPMENT, OR LOSS OF FUNCTIONAL EFFECTIVENESS.

To interface a unit to a VFD, select the appropriate motor you wish to control. Connect the appropriate output A1 or A2 to the appropriate VFD analog input, noting polarity. (Consult your VFD manual for specific analog input locations). For each motor connect the appropriate directional inputs to your VFD. (Consult your VFD manual for directional input locations).



WARNING

THE MECHANICAL DIRECTIONAL RELAYS ARE ONLY RATED FOR 8 AMPS DC. THE SOLID-STATE DIRECTIONALS RELAYS IF SUPPLIED CANNOT SWITCH A CONTACTOR. USE CAUTION ON HOOKING OTHER DEVICES SUCH AS ALARMS DIRECTLY ON THE DIRECTIONAL RELAYS. FAILURE TO FOLLOW THIS WARNING COULD RESULT IN SERIOUS INJURY OR DEATH AND DAMAGE TO EQUIPMENT.

D-3-5. Adjustment.

Adjust the analog output 0-10 VDC adjustment (Figure D-4. Item 1. above) to 10 volts DC maximum with the transmitter switch fully depressed.

D-3-6. Spare Parts.

Relay part numbers:

E10109-3	Mechanical	K1-K4 – K132-0 K5, K6 – K2115-0
E10109-1	Solid state	K1-K4 – IC2822-1 K5, K6 – K2115-0
E10116-3	Mechanical	K1, K2 – K1304-0 K3, K4 – K132-0 K5 – K2115-0
E10116-0	Solid state	K1, K2 – K1304-0 K3, K4 – IC2822-1 K5 – K2115-0

Fuse part numbers:

E10109-3	Mechanical	F1A-F4A – F2711-0 F5, F6 – F2704-0
E10109-1	Solid state	F1A-F4A, F5, F6 – F2704-0
E10116-3	Mechanical	F1A-F4A – F2711-0 F6 – F2704-0
E10116-0	Solid state	F1A-F2A – F2711-0 F3A-F4A, F6 – F2704-0

D-3-7. Check Out.

Complete the above for each crane motor function. Verify all your connections and voltages before engaging the Master Relay.

Section 3 – Operation and Setup (Continued)

D-3-8. Transmitter Programming. Normally the transmitter does not need programming refer to this section for special crane motor configurations, arrange buttons on pendant or disable time-out-timer.

D-3-8.1. Transmitter programming Sw3 (See 10K manual for physical location of transmitter switches).

D-3-8.1.1. Positions 1-3 (Pendant only) Switch Positioning.

(Standard configuration all "OFF").

The functional positions of the various buttons can be moved by transmitter dip switch Sw3 also. Positions Sw3-1 through Sw3-3 control these. No change in receiver wiring is needed to use these. See 10K manual for switch verses button configurations.

D-3-8.1.2. Positions 1-3 (JLTX only) no function.

(Keep turned "OFF").

D-3-8.1.3. Positions 4-7 no function.

(Keep turned "OFF").

D-3-8.1.4. Position 8 Time-out-timer Disable.

(Normally keep turned "OFF").

The transmitter has an approximate 15-minute time-out-timer. If the transmitter is not used for over 15 minutes it will shut down. This transmitter time-out-timer function is transmitter dip switch selectable. Sw3 position 8 disables the time-out-timer. Turning Sw3-8 "ON" disables the time-out-timer.

D-3-8.2. Transmitter programming Sw4

D-3-8.2.1. Position 1-2 Mode Enable. (Standard Mode 1 keep 1-2 turned "OFF").

D-3-8.2.2. Position 3 Disable Tandem for hoist and trolley.

(Normally keep turned "OFF").

For cranes with auxiliary hoists and/or trolleys, turning this switch "ON" disables the transmitter selector switch "B" position (both function) that selects tandem operation of hoist or trolley.

D-3-8.2.3. Position 4 Invert Crane Select Aux. Outputs.

(Normally keep turned "OFF").

For cranes that use the select function only, turning this switch "ON" inverts the select function operation so that the relay closes for the unselected function.

D-3-8.2.4. Positions 5-7 Extended Crane Control Configurations.

(Standard all "OFF" otherwise see TABLES 1 through 4, pages 23-62)

The 10K Stepless Pendant and JLTX transmitter is available with extended crane control configurations. These options are switch configurable on the transmitter. The eight-position dip switch Sw4 on the transmitter can provide many configurations. The TABLE(s) on pages 23-62 show the available configurations and the switch programming needed to provide them. If a configuration listed in the following is preferred over the standard configuration, please reprogram Sw3 and Sw4 respectively on the transmitter.

D-3-8.2.5. Position 8 no function.

(Keep turned "OFF").

D-3-9. Transmitter Firmware.

See Section 5 - Firmware pages 63-64.

D-3-10. Multibox and Optional Output Board:



WARNING

IF YOUR UNIT WAS NOT ORDERED WITH MULTIBOX DO NOT ATTEMPT TO PROGRAM MULTIBOX IN THE FIELD. TELEMOTIVE MUST COORDINATE ACCESS CODE ASSIGNMENTS WITH THE TRANSMITTERS PRIOR TO ENABLING MULTIBOX. PLEASE CONTACT TELEMOTIVE IF YOU NEED TO ADD MULTIBOX. FAILURE TO FOLLOW THIS WARNING COULD RESULT IN SERIOUS INJURY OR DEATH AND DAMAGE TO EQUIPMENT.

If Multibox is used (Receiver switch Sw3-3 is "ON" and the Optional Output Board is installed in the receiver). The outputs are as follows:

C1-C2 Defined per type

C3 MULTIBOX 1

C4 MULTIBOX 2

C5 MULTIBOX 3

C6 MULTIBOX 4

Section 3 – Operation and Setup (Continued)

D-3-11. Latching of Auxiliary Relays

Certain auxiliary relays can be set to latch (be toggled on and off) by setting dip switch S2 positions 6-8 on the Receiver CPU Board. If an

Aux function is latchable it is noted in the programming diagram by the following note (LATCHABLE S2-#) where # is the switch position 6-8 that must be turned on for the latching function.

Optional 110 Volt Wiring

Power supply wiring is accomplished through connector J1 on the power supply board. The connections labeled 240, 120, N and GND are wired to the appropriate supply connections per the wiring diagrams. An extra connection 120 is provided for 120 Volt applications only for jumpering to Pins 2 and 6 of the Master Relay (MR) K1 on the power supply board. The unit may optionally be wired as in the diagram below. All other wiring is accomplished per the attached tables.

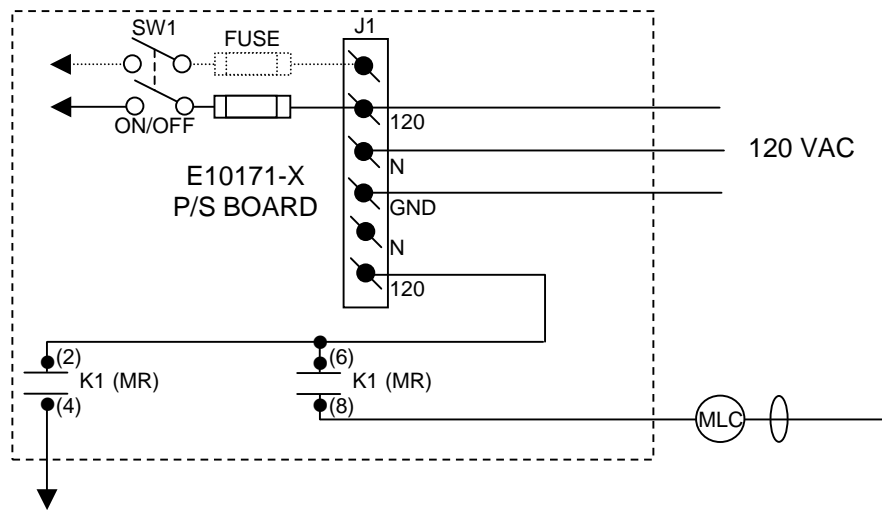

Section 3 – Operation and Setup (Continued)

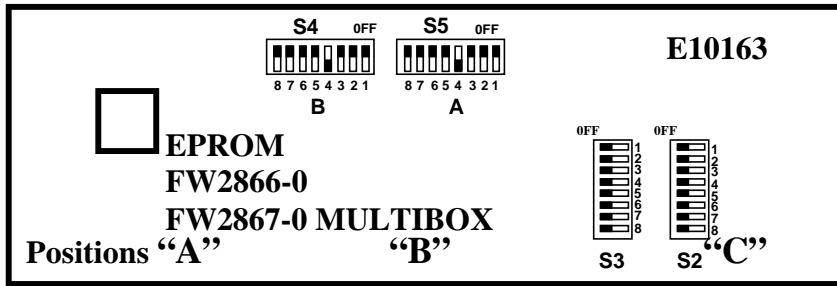

10KS1202P7H2

Stepless Hoist
Stepped 2-Speed
Trolley and Bridge

See Table 1 pages 23-32 for alternate stepped crane motor wiring configurations.

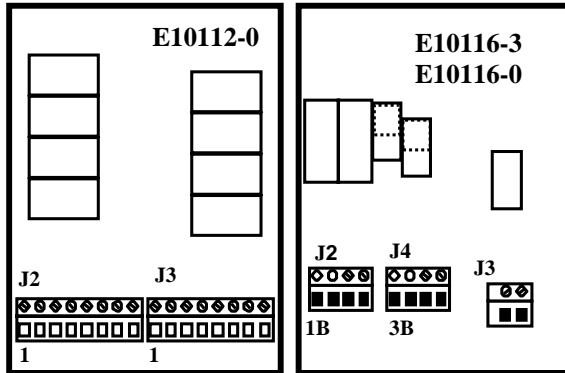

- J2-8 - J3-8 - AUX 4 (ALARM)
 - J2-7 - J3-7 - AUX 3
 - J2-6 - J3-6 - BRIDGE DIR 1
 - J2-5 - J3-5 - BRIDGE 2ND SPD
 - J2-4 - J3-4 - BRIDGE DIR 2
 - J2-3 - J3-3 - TROLLEY DIR 1
 - J2-2 - J3-2 - TROLLEY 2ND SPD
 - J2-1 - J3-1 - TROLLEY DIR 2
- 4A-4B - HOIST DIR 2
 - 3A-3B - HOIST DIR 1
 - 2A-2B - AUX 2
 - 1A-1B - AUX 1
- A2 - HOIST ANALOG
 - GND - GROUND ANALOG

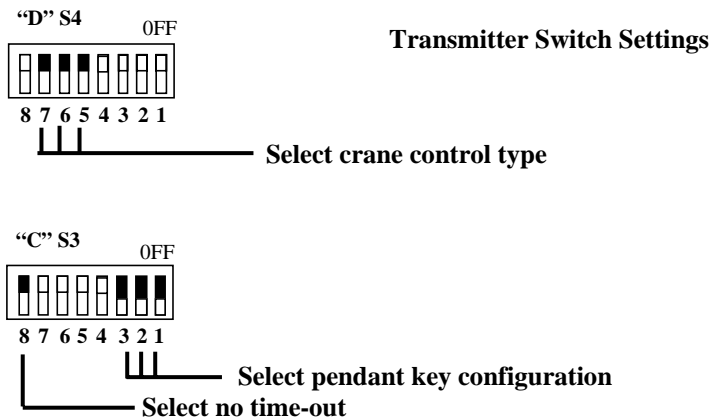
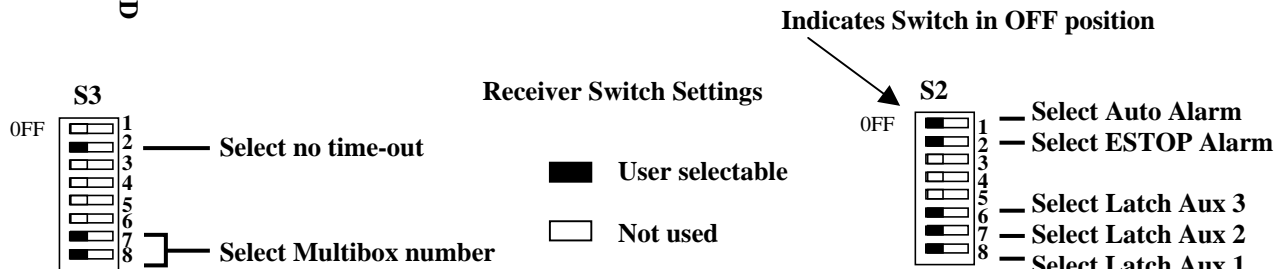

Transmitter Models:
10KS1202P7
10KLS1202J2
10KS1202J2

Section 3 – Operation and Setup (Continued)

10KS1207P7H2
Stepless Hoist,
Trolley and Bridge

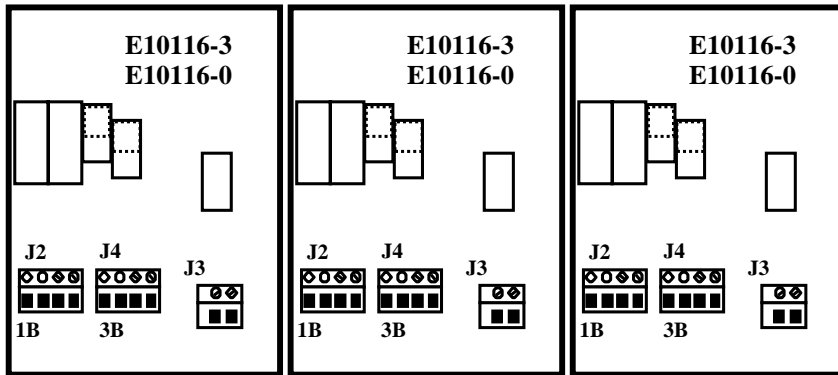
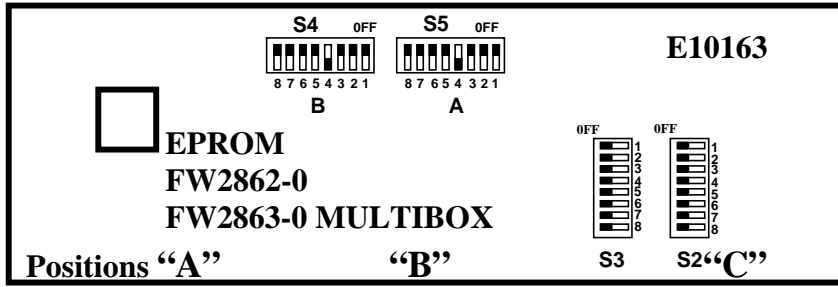

4A-4B - BRIDGE DIR 2
 3A-3B - BRIDGE DIR 1
 2A-2B - AUX 3
 1A-1B - AUX 4 (ALARM)

A2 - BRIDGE ANALOG
 GND - GROUND ANALOG

4A-4B - TROLLEY DIR 2
 3A-3B - TROLLEY DIR 1
 2A-2B - AUX 1
 1A-1B - AUX 2

A2 - TROLLEY ANALOG
 GND - GROUND ANALOG

4A-4B - HOIST DIR 2
 3A-3B - HOIST DIR 1
 2A-2B - AUX 5
 1A-1B - AUX 6

A2 - HOIST ANALOG
 GND - GROUND ANALOG

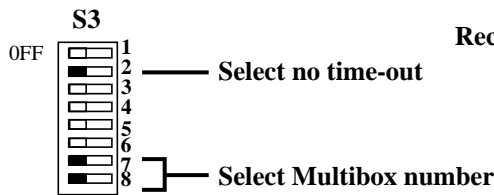

Receiver Switch Settings

User selectable
 Not used

Indicates Switch in OFF position

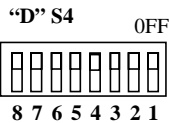
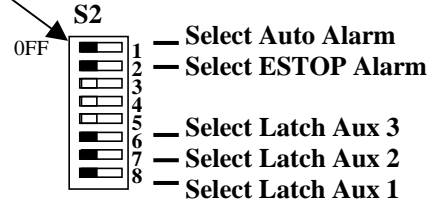

Transmitter Switch Settings

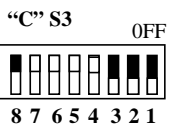

Select pendant key configuration
 Select no time-out

Transmitter Models:
10KS1207P7
10KLS1207J2
10KS1207J2

Section 3 – Operation and Setup (Continued)



10KS1220P7H2

Stepped 2-Speed Hoist
Stepless

Trolley and Bridge

See Table 2 pages 33-40 for
alternate stepped crane
motor wiring configurations.

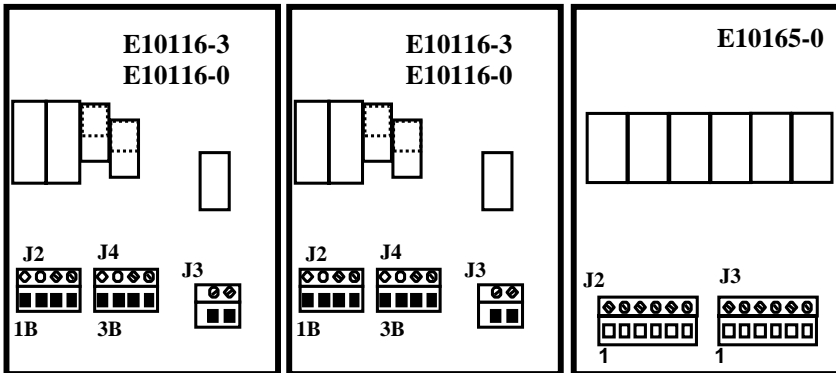

4A-4B - BRIDGE DIR 2
3A-3B - BRIDGE DIR 1
2A-2B - AUX 3
1A-1B - AUX 4 (ALARM)

A2 - BRIDGE ANALOG
GND - GROUND ANALOG

4A-4B - TROLLEY DIR 2
3A-3B - TROLLEY DIR 1
2A-2B - AUX 1
1A-1B - AUX 2

A2 - TROLLEY ANALOG
GND - GROUND ANALOG

J2-6 - J3-6 - HOIST DIR 2
J2-5 - J3-5 - HOIST 2ND SPD
J2-4 - J3-4 - HOIST DIR 1
J2-3 - J3-3 - HOIST (configurable)
J2-2 - J3-2 - AUX 5
J2-1 - J3-1 - AUX 6

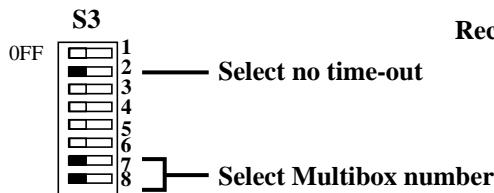

Receiver Switch Settings

■ User selectable
□ Not used

Indicates Switch in OFF position

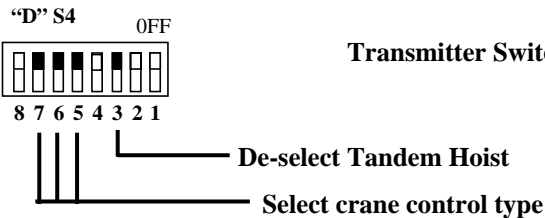
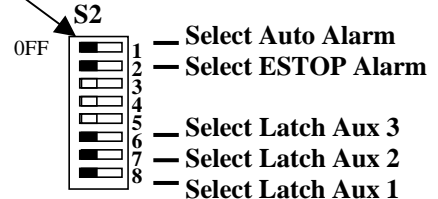

Transmitter Switch Settings

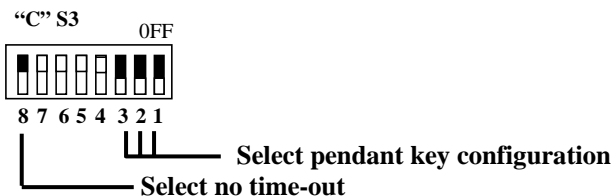

Transmitter Models:

10KS1220P7

10KLS1220J2

10KS1220J2

Section 3 – Operation and Setup (Continued)

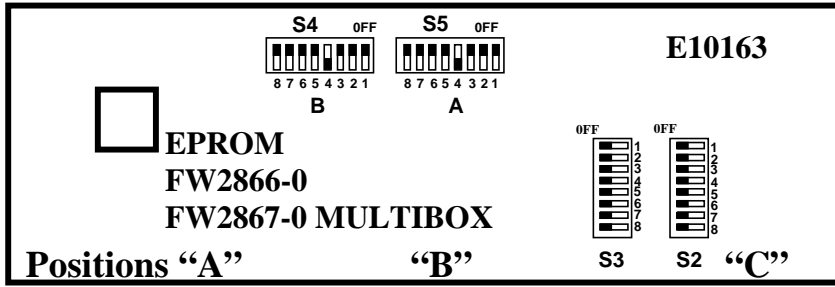

10KS1221P7H2

Stepped 2-Speed Hoist and
Trolley
Stepless Bridge

See Table 3 pages 41-52 for
alternate stepped crane
motor wiring configurations.

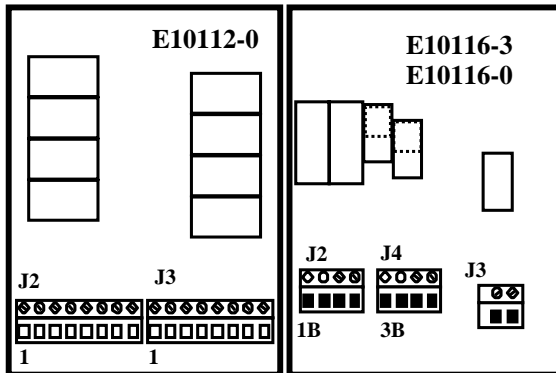

- E10112-0**
- J2-8 - J3-8 - AUX 4 (ALARM)
 - J2-7 - J3-7 - AUX 3
 - J2-6 - J3-6 - HOIST DIR 1
 - J2-5 - J3-5 - HOIST 2ND SPD
 - J2-4 - J3-4 - HOIST DIR 2
 - J2-3 - J3-3 - TROLLEY DIR 1
 - J2-2 - J3-2 - TROLLEY 2ND SPD
 - J2-1 - J3-1 - TROLLEY DIR 2
- E10116-3
E10116-0**
- 4A-4B - BRIDGE DIR 2
 - 3A-3B - BRIDGE DIR 1
 - 2A-2B - AUX 2
 - 1A-1B - AUX 1
 - A2 - BRIDGE ANALOG
 - GND - GROUND ANALOG

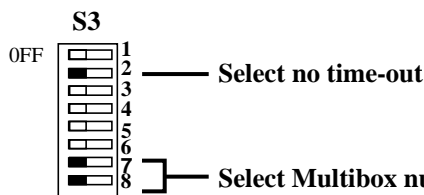

Receiver Switch Settings

- User selectable
- Not used

Indicates Switch in OFF position

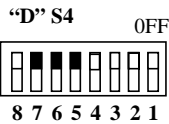
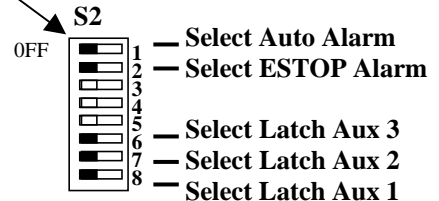

Transmitter Switch Settings

Select crane control type

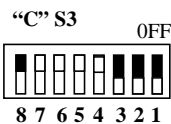

Select pendant key configuration

Select no time-out

Transmitter Models:

10KS1221P7
10KLS1221J2
10KS1221J2

Section 3 – Operation and Setup (Continued)

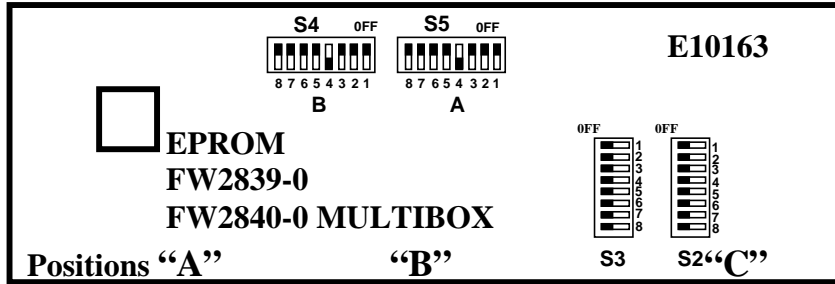

10KS1603P5H2

**Stepless Hoist/Aux Hoist
Stepped 3-Speed
Trolley and Bridge**

See Table 4 pages 53-62 for alternate stepped crane motor wiring configurations.

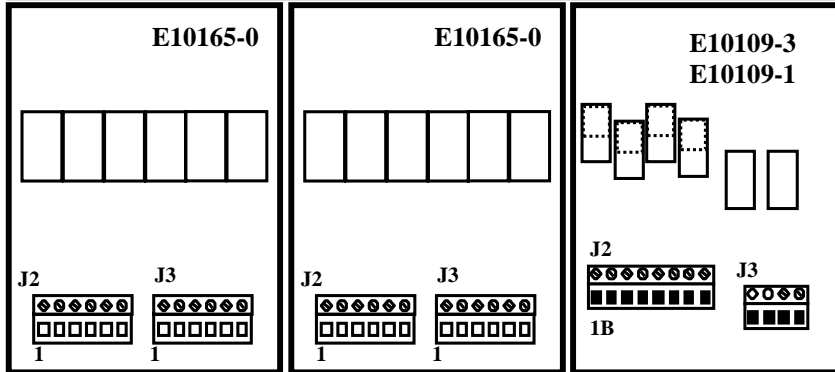

J2-6 - J3-6 - BRIDGE DIR 2
J2-5 - J3-5 - BRIDGE DIR 1
J2-4 - J3-4 - AUX 1
J2-3 - J3-3 - AUX 2
J2-2 - J3-2 - AUX 3
J2-1 - J3-1 - AUX 4 (ALARM)

J2-6 - J3-6 - TROLLEY 3RD SPD
J2-5 - J3-5 - TROLLEY 2ND SPD
J2-4 - J3-4 - TROLLEY DIR 2
J2-3 - J3-3 - TROLLEY DIR 1
J2-2 - J3-2 - BRIDGE 3RD SPD
J2-1 - J3-1 - BRIDGE 2ND SPD

A2 - HOIST ANALOG
GND - GROUND ANALOG
A1 - AUX HOIST ANALOG
GND - GROUND ANALOG
4A-4B - HOIST DIR 2
3A-3B - HOIST DIR 1
2A-2B - AUX HOIST DIR 2
1A-1B - AUX HOIST DIR 1

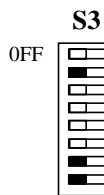

Receiver Switch Settings

Select no time-out

Select Multibox number

■ User selectable

□ Not used

Indicates Switch in OFF position

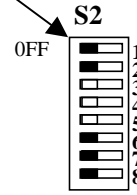

- Select Auto Alarm
- Select ESTOP Alarm
- Select Latch Aux 3
- Select Latch Aux 2
- Select Latch Aux 1

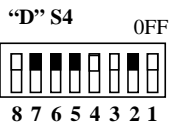

Transmitter Switch Settings

De-select Tandem Hoist

Select crane control type

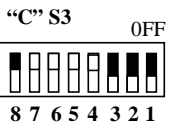

Select pendant key configuration

Select no time-out

Transmitter Models:

10KS1603P5

10KLS1603J1

10KS1603J1

Section 3 – Operation and Setup (Continued)

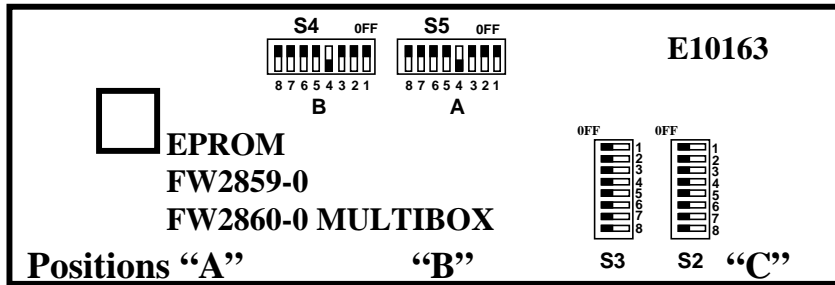

10KS1607P5H2
Stepless Hoist/Aux Hoist,
Trolley and Bridge

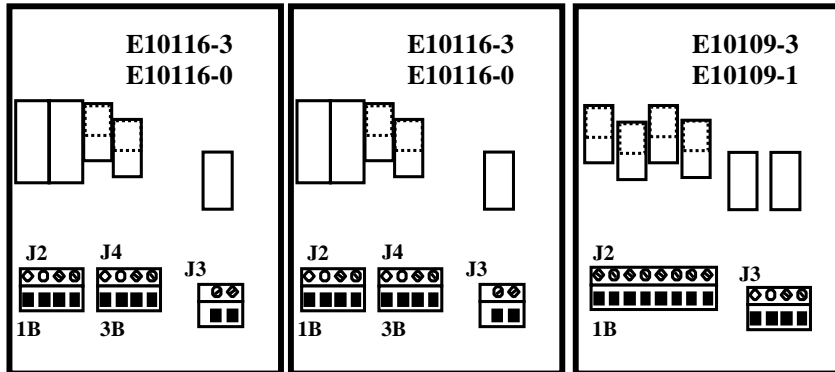

- 4A-4B - BRIDGE DIR 2
 3A-3B - BRIDGE DIR 1
 2A-2B - AUX 3
 1A-1B - AUX 4 (ALARM)
- A2 - BRIDGE ANALOG
 GND - GROUND ANALOG
- 4A-4B - TROLLEY DIR 2
 3A-3B - TROLLEY DIR 1
 2A-2B - AUX 1
 1A-1B - AUX 2
- A2 - TROLLEY ANALOG
 GND - GROUND ANALOG
- 4A-4B - AUX HOIST DIR 2
 3A-3B - AUX HOIST DIR 1
 2A-2B - HOIST DIR 2
 1A-1B - HOIST DIR 1
- A2 - HOIST ANALOG
 GND - GROUND ANALOG
- A1 - AUX HOIST ANALOG
 GND - GROUND ANALOG

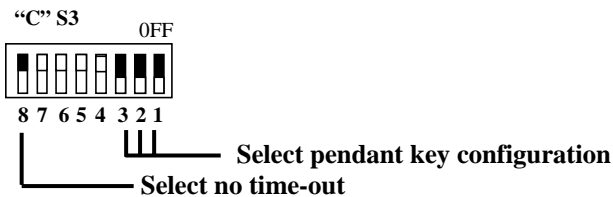
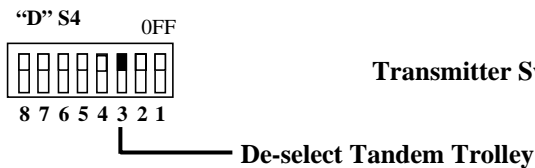
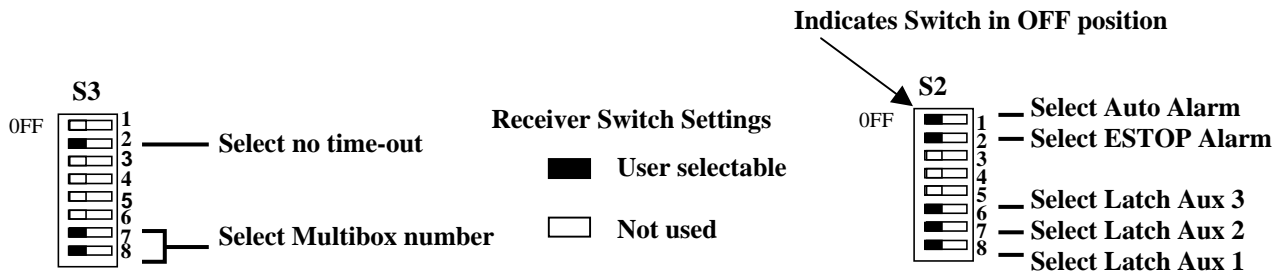

Transmitter Models:
10KS1607P5
10KLS1607J1
10KS1607J1

Section 3 – Operation and Setup (Continued)

10KS2407P5H2

Stepless Hoist/Aux Hoist
Trolley/Aux Trolley and
Bridge

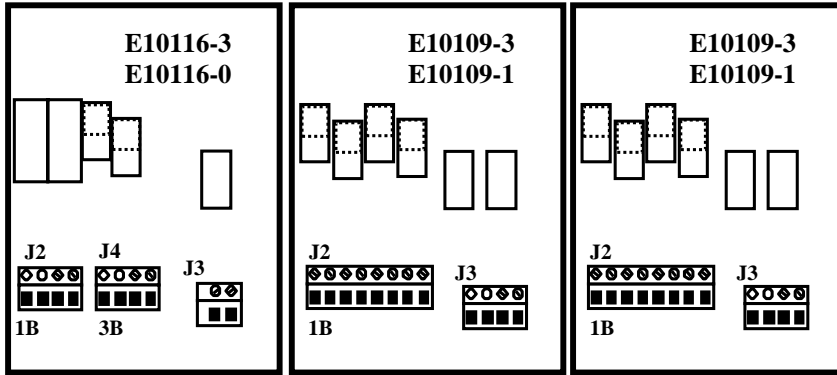
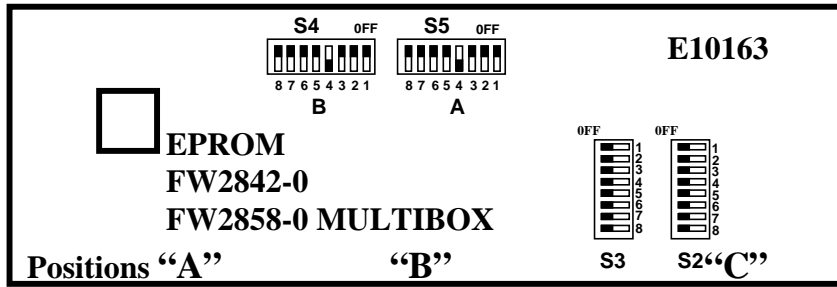

- A2 - AUX HOIST ANALOG
 - GND - GROUND ANALOG
 - A1 - HOIST ANALOG
 - GND - GROUND ANALOG
 - 4A-4B - AUX HOIST DIR 2
 - 3A-3B - AUX HOIST DIR 1
 - 2A-2B - AUX DIR 3
 - 1A-1B - AUX 4 (ALARM)
- A2 - BRIDGE ANALOG
 - GND - GROUND ANALOG
 - 4A-4B - BRIDGE DIR 2
 - 3A-3B - BRIDGE DIR 1
 - 2A-2B - AUX 3
 - 1A-1B - AUX 4 (ALARM)
- A2 - AUX TROLLEY ANALOG
 - GND - GROUND ANALOG
 - A1 - TROLLEY ANALOG
 - GND - GROUND ANALOG
 - 4A-4B - AUX TROLLEY DIR 2
 - 3A-3B - AUX TROLLEY DIR 1
 - 2A-2B - TROLLEY DIR 2
 - 1A-1B - TROLLEY DIR 1
- A2 - AUX TROLLEY ANALOG
 - GND - GROUND ANALOG
 - A1 - TROLLEY ANALOG
 - GND - GROUND ANALOG
 - 4A-4B - AUX TROLLEY DIR 2
 - 3A-3B - AUX TROLLEY DIR 1
 - 2A-2B - HOIST DIR 2
 - 1A-1B - HOIST DIR 1

Indicates Switch in OFF position

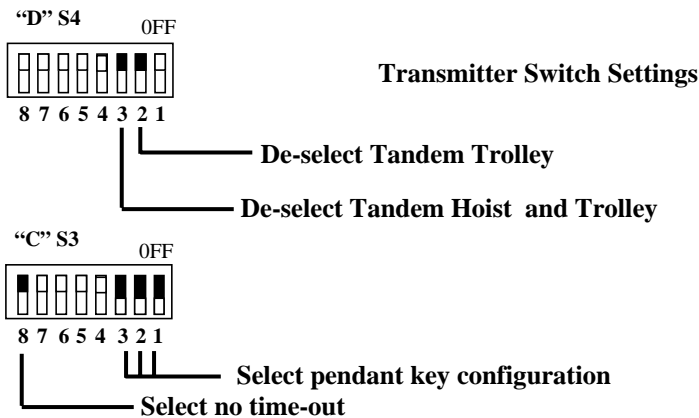
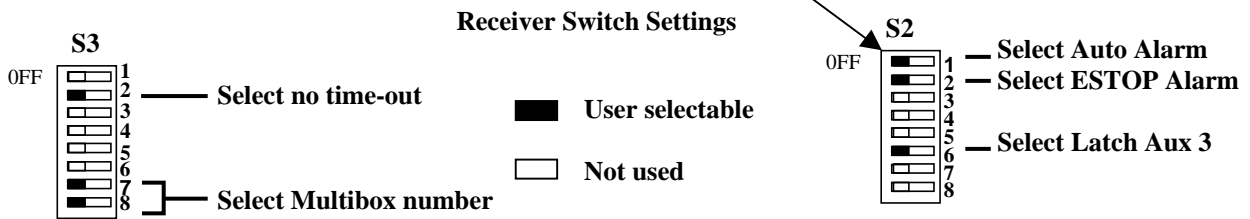

Transmitter Models:
10KS2407P5
10KLS2407J1
10KS2407J1

Section 4 – Optional Wiring Tables

D-4-1. The Optional Wiring Tables begin on the next page.

Tables are in page pairs. Wiring and programming diagrams are opposite each other on separate pages.

D-4-2. The Use of These Tables:

These tables are for use with cranes having combinations of Stepless and Stepped motors. These tables give the detailed relay sequencing and wiring of the stepped motor outputs. Some crane motors, i.e. Demag, P&H and Acco, have special relay sequencing or require additional relays for the stepped motors. An example would be a unique and separate 2nd speed contact for direction 1 versus direction 2. If special crane configuration is required look through these tables under the particular section that matches the application, find the appropriate configuration setting in the “Programming” section and program the transmitter appropriately. When wiring the unit please use the appropriate “Wiring Diagram” on the opposite page for installation.

D-4-3. Tables of Wiring and Programming Diagrams Legend.

The following tables give various extended crane configurations. Functional terms like Trolley East and Hoist Up match standard transmitter labeling from the factory. The following legend is used in these diagrams:

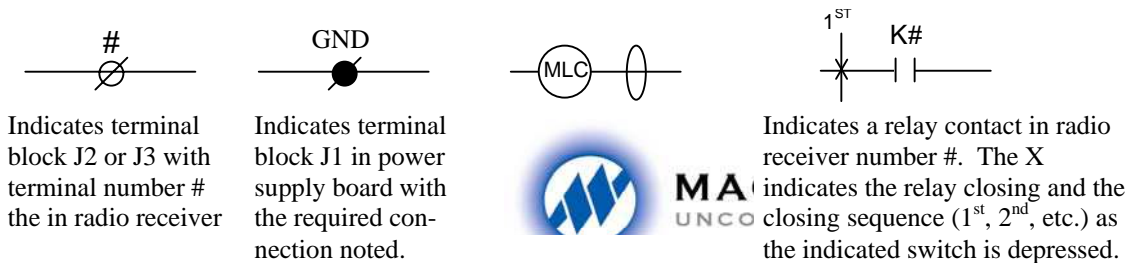

In the following wiring diagrams the relay outputs AJ2, BJ2 and CJ2 have listed next to the right of them the appropriate motor function they control, i.e., trolley, hoist etc. Proper installation requires that this output be wired to a contactor controlling that function and that the contactor has the proper arc suppressor across it.

Section 4 – Optional Wiring Tables

TABLE 1(a)
Crane Control Type Selection:
10KS1202P7, 10K Stepless Hoist, 2-Speed Trolley and Bridge

TYPE 0 WIRING DIAGRAM
STANDARD CONFIGURATION:
STEPLESS HOIST, 2-SPD. TROLLEY and BRIDGE

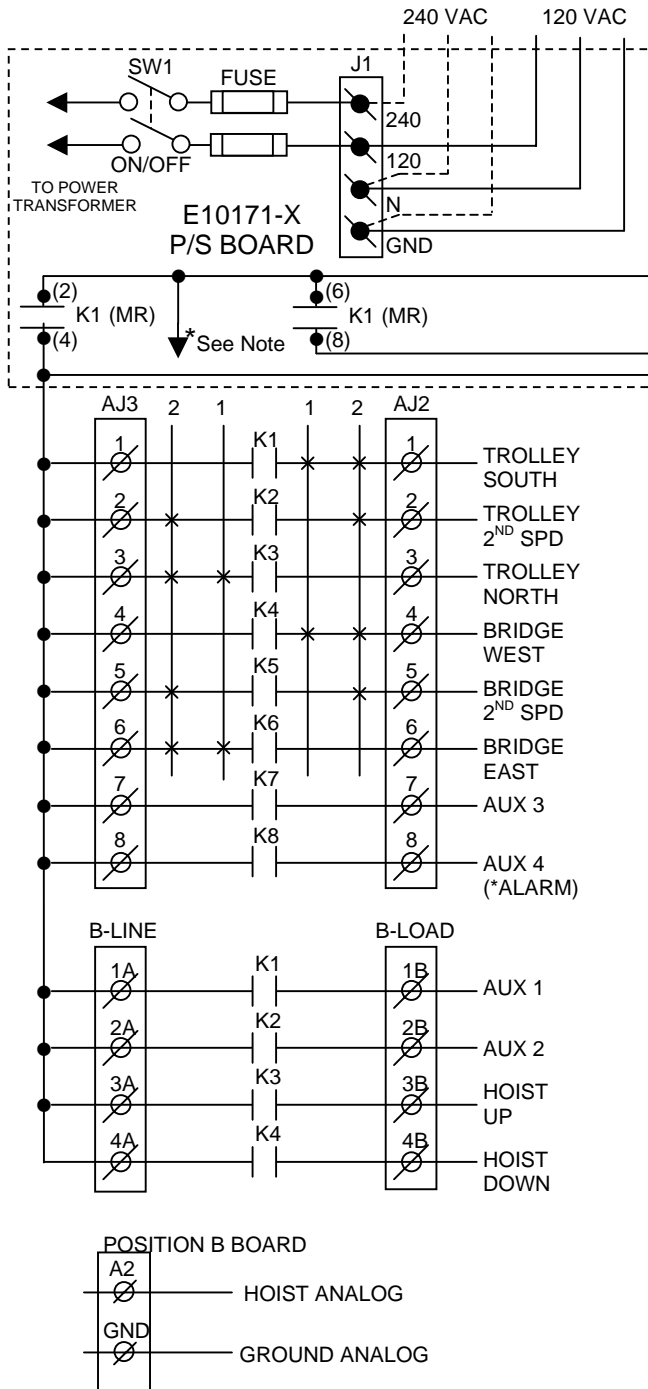

***NOTE:** If it is necessary to operate the Alarm Function during E-Stop condition, wire the input to the alarm relay “AJ3-8” for the alarm function to the control power hot side (relay “K1” (MR) on P/S Board de-energized).

Optional receiver output board (E10165-X).

Multibox outputs available with factory installed Multibox option only.

All connections to outputs AJ2, B-LOAD 1B, 2B and CJ2 are to contactors, with proper arc suppressors across them, controlling the appropriate listed function to the right.

**Aux outputs 5 and 6 available with Multibox. Aux outputs 5 to 6 available with Multibox disabled.

Section 4 – Optional Wiring Tables (Continued)

TABLE 1(a)

**Crane Control Type Selection:
10KS1202P7, 10K Stepless Hoist, 2-Speed Trolley and Bridge**

TYPE 0 PROGRAMMING

STANDARD CONFIGURATION:

STEPLESS HOIST, 2-SPD. TROLLEY and BRIDGE

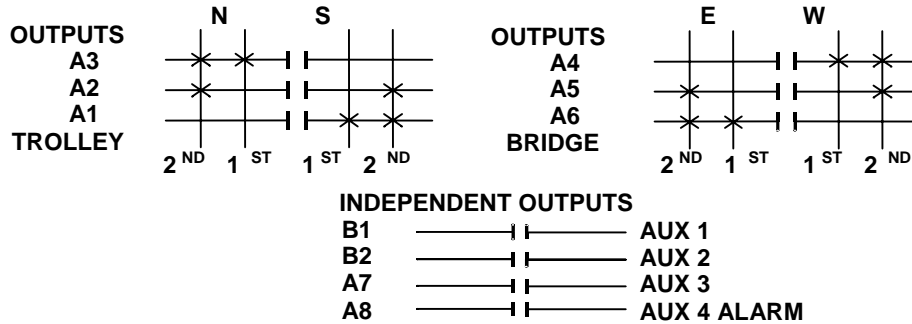

STANDARD OUTPUTS	STANDARD OUTPUTS	OPTIONAL OUTPUT BOARD OPTION #1	OPTIONAL OUTPUT BOARD OPTION #2
A1 TROLLEY SOUTH	B1 AUX 1 (LATCHABLE S2-8)	C1 AUX 5	C1 AUX 5
A2 TROLLEY 2 ND SPEED	B2 AUX 2 (LATCHABLE S2-7)	C2 AUX 6	C2 AUX 6
A3 TROLLEY NORTH	B3 HOIST UP	C3 MULTIBOX 1	C3
A4 BRIDGE WEST	B4 HOIST DOWN	C4 MULTIBOX 2	C4
A5 BRIDGE 2 ND SPEED		C5 MULTIBOX 3	C5
A6 BRIDGE EAST		C6 MULTIBOX 4	C6
A7 AUX 3 (LATCHABLE S2-6)			
A8 AUX 4 (ALARM)			

NOTE: To use Optional Receiver Output Board, the Optional Output board must be installed and connected. With the Optional Output Board installed, Receiver Switch Sw3-3 must “ON” for Output Option #1 and “OFF” for Output Option #2.

Transmitter Switch Select: “D” Switch settings Sw4-5 to Sw4-7 are defined as follows:

TRANSMITTER SWITCH SETTINGS: TYPE	Sw4-7	Sw4-6	Sw4-5
0	OFF	OFF	OFF

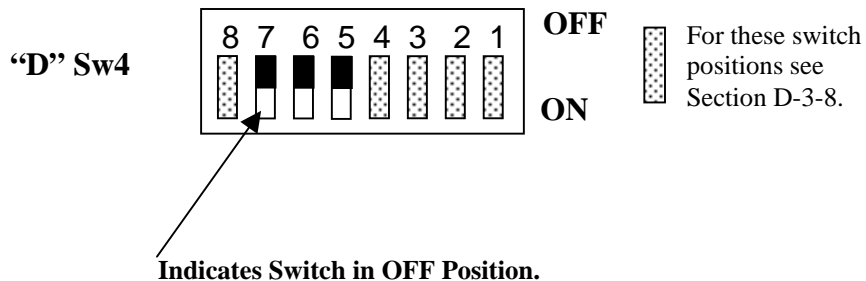

Section 4 – Optional Wiring Tables (Continued)

TABLE 1(b)

**Crane Control Type Selection:
10KS1202P7, 10K Stepless Hoist, 2-Speed Trolley and Bridge**

TYPE 1 WIRING DIAGRAM

2-SPD WITH DIRECTIONAL CONTROL: TROLLEY and BRIDGE

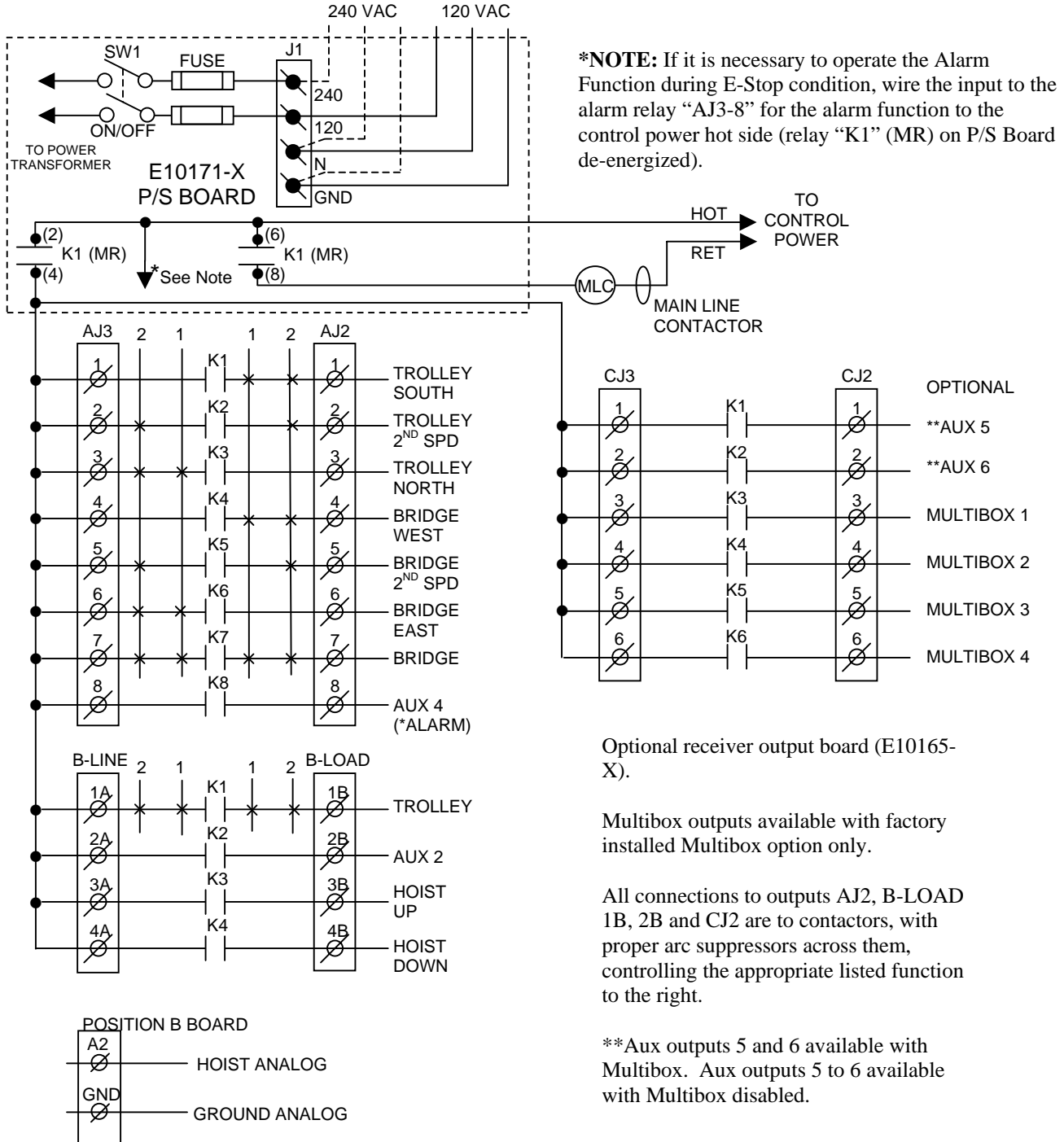

Section 4 – Optional Wiring Tables (Continued)

TABLE 1(b)

Crane Control Type Selection:

10KS1202P7, 10K Stepless Hoist, 2-Speed Trolley and Bridge

TYPE 1 PROGRAMMING

2-SPD WITH DIRECTIONAL CONTROL: TROLLEY and BRIDGE

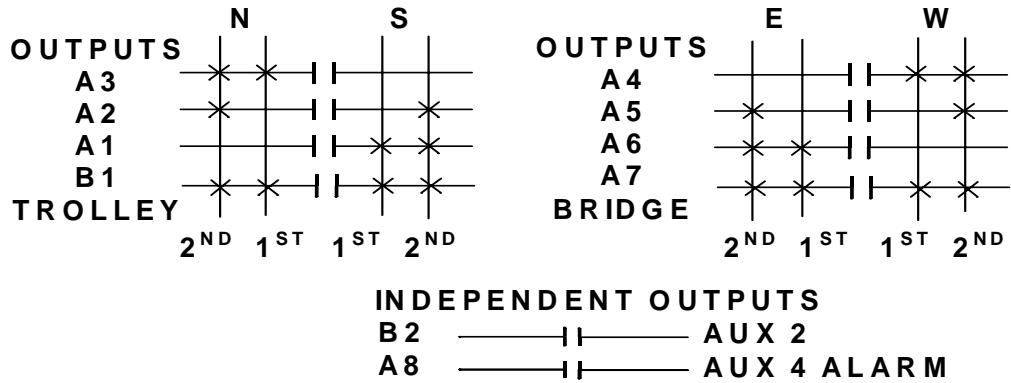

STANDARD OUTPUTS	STANDARD OUTPUTS	OPTIONAL OUTPUT BOARD OPTION #1	OPTIONAL OUTPUT BOARD OPTION #2
A1 TROLLEY SOUTH	B1 TROLLEY	C1 AUX 5	C1 AUX 5
A2 TROLLEY 2 ND SPEED	B2 AUX 2 (LATCHABLE S2-7)	C2 AUX 6	C2 AUX 6
A3 TROLLEY NORTH	B3 HOIST UP	C3 MULTIBOX 1	C3
A4 BRIDGE WEST	B4 HOIST DOWN	C4 MULTIBOX 2	C4
A5 BRIDGE 2 ND SPEED		C5 MULTIBOX 3	C5
A6 BRIDGE EAST		C6 MULTIBOX 4	C6
A7 BRIDGE			
A8 AUX 4 (ALARM)			

NOTE: To use Optional Receiver Output Board, the Optional Output board must be installed and connected. With the Optional Output Board installed, Receiver Switch Sw3-3 must “ON” for Output Option #1 and “OFF” for Output Option #2.

Transmitter Switch Select: Switch settings Sw4-5 to Sw4-7 are defined as follows :

TRANSMITTER SWITCH SETTINGS: TYPE Sw4-7 Sw4-6 Sw4-5
0 OFF OFF ON

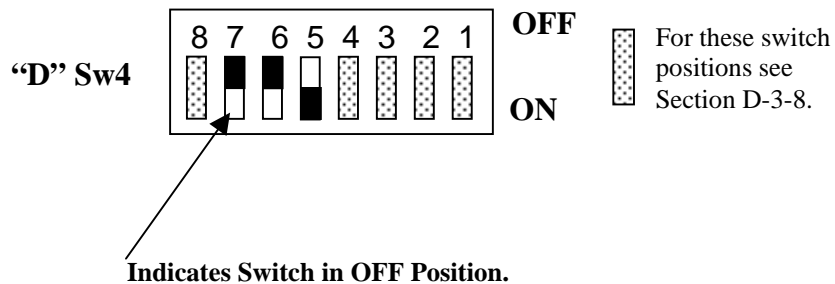

Section 4 – Optional Wiring Tables (Continued)

TABLE 1(c)

Crane Control Type Selection:

10KS1202P7, 10K Stepless Hoist, 2-Speed Trolley and Bridge

TYPE 2 WIRING DIAGRAM

2-SPEED, 2-WINDINGS: TROLLEY and BRIDGE

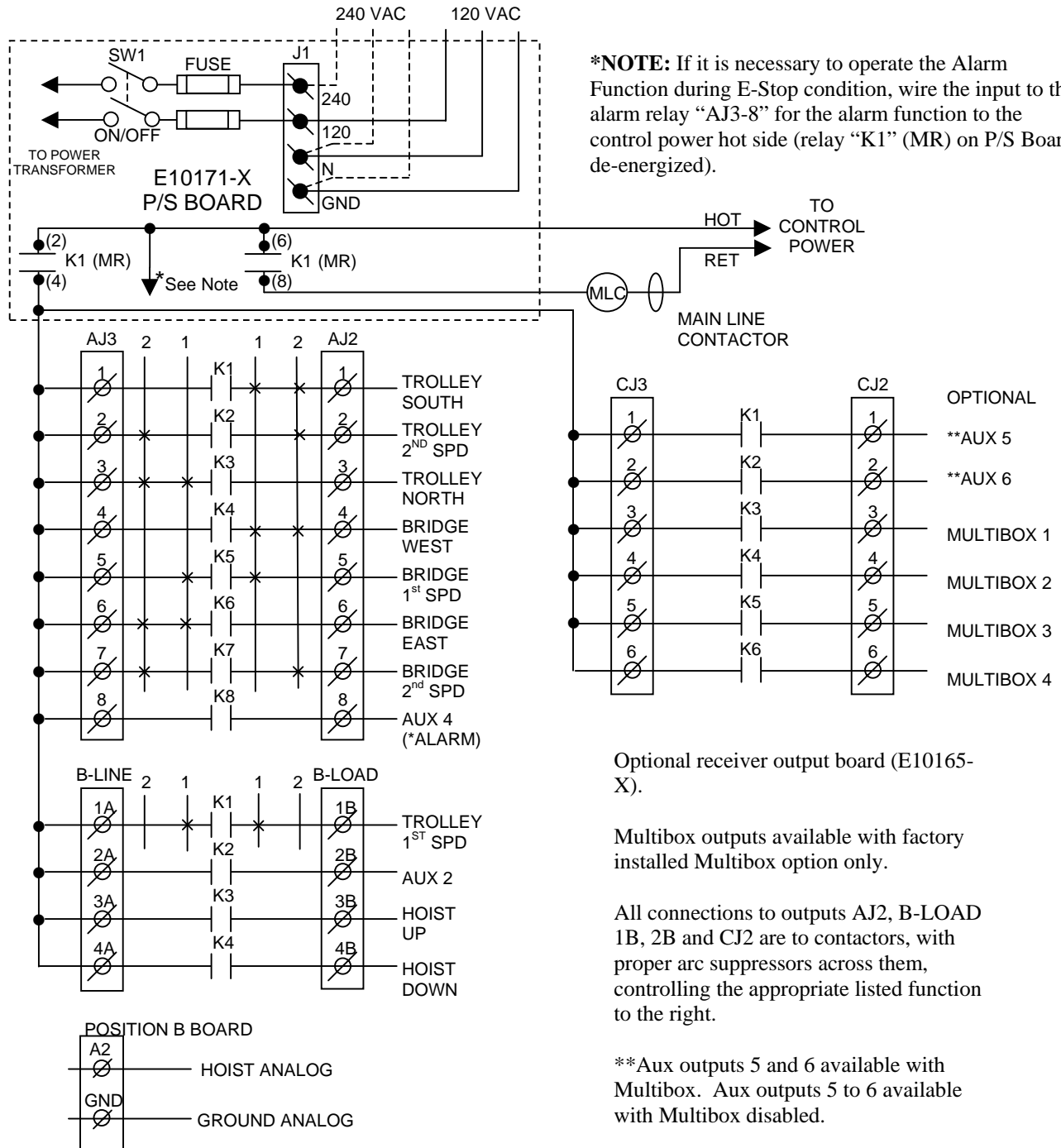

Section 4 – Optional Wiring Tables (Continued)

TABLE 1(c)

Crane Control Type Selection:

10KS1202P7, 10K Stepless Hoist, 2-Speed Trolley and Bridge

TYPE 2 PROGRAMMING

2-SPEED, 2-WINDINGS: TROLLEY and BRIDGE

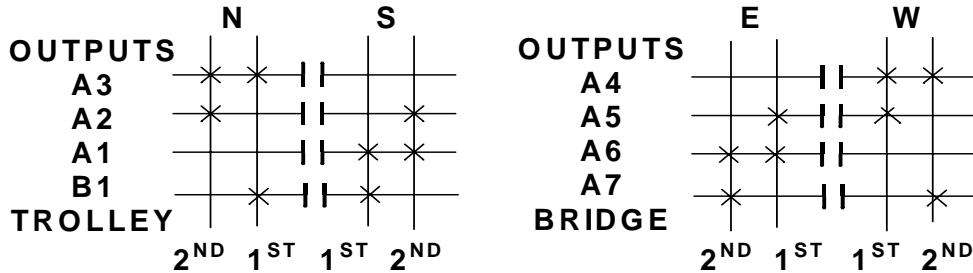

INDEPENDENT OUTPUTS

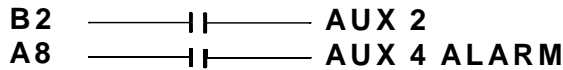

STANDARD OUTPUTS	STANDARD OUTPUTS	OPTIONAL OUTPUT BOARD OPTION #1	OPTIONAL OUTPUT BOARD OPTION #2
A1 TROLLEY SOUTH	B1 TROLLEY 1 ST SPEED	C1 AUX 5	C1 AUX 5
A2 TROLLEY 2 ND SPEED	B2 AUX 2 (LATCHABLE S2-7)	C2 AUX 6	C2 AUX 6
A3 TROLLEY NORTH	B3 HOIST UP	C3 MULTIBOX 1	C3
A4 BRIDGE WEST	B4 HOIST DOWN	C4 MULTIBOX 2	C4
A5 BRIDGE 1 ST SPEED		C5 MULTIBOX 3	C5
A6 BRIDGE EAST		C6 MULTIBOX 4	C6
A7 BRIDGE 2 ND SPEED			
A8 AUX 4 (ALARM)			

NOTE: To use Optional Receiver Output Board, the Optional Output board must be installed and connected. With the Optional Output Board installed, Receiver Switch Sw3-3 must “ON” for Output Option #1 and “OFF” for Output Option #2.

Transmitter Switch Select: “D” Switch settings Sw4-5 to Sw4-7 are defined as follows :

TRANSMITTER SWITCH SETTINGS: TYPE	<i>Sw4-7</i>	<i>Sw4-6</i>	<i>Sw4-5</i>
	2	OFF	ON
		ON	OFF

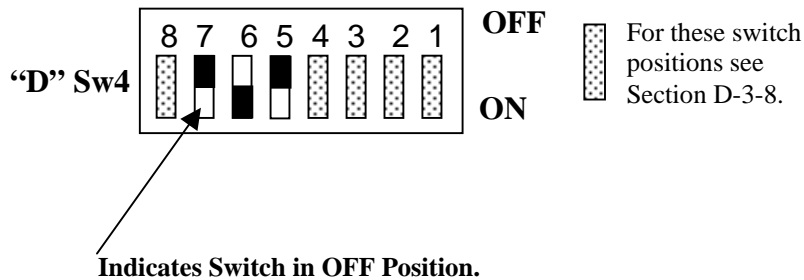

Section 4 – Optional Wiring Tables (Continued)

TABLE 1(d)

**Crane Control Type Selection:
10KS1202P7, 10K Stepless Hoist, 2-Speed Trolley and Bridge
TYPE 3 WIRING DIAGRAM
ACCO CONTROLS: TROLLEY and BRIDGE**

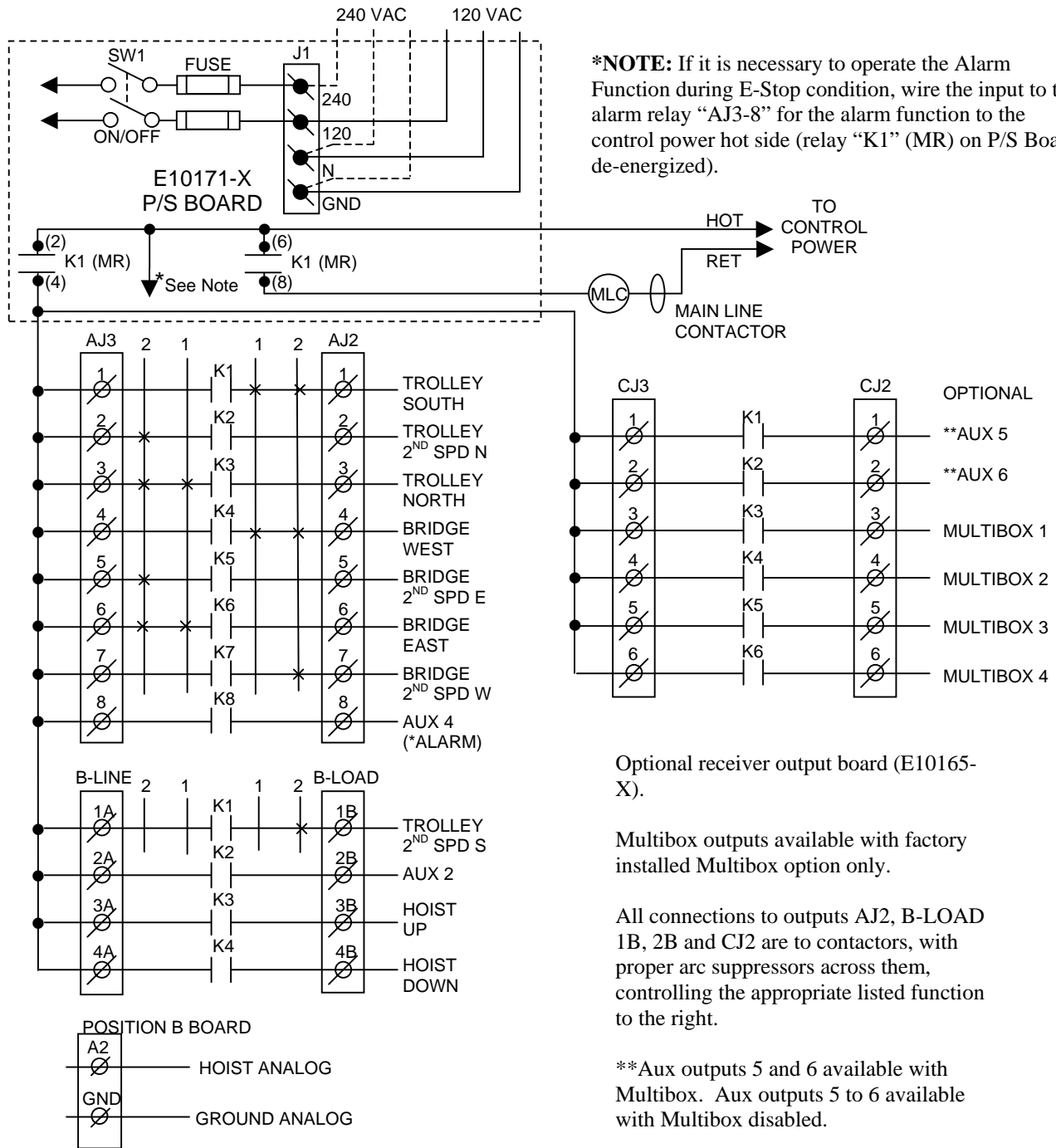

***NOTE:** If it is necessary to operate the Alarm Function during E-Stop condition, wire the input to the alarm relay “AJ3-8” for the alarm function to the control power hot side (relay “K1” (MR) on P/S Board de-energized).

Optional receiver output board (E10165-X).

Multibox outputs available with factory installed Multibox option only.

All connections to outputs AJ2, B-LOAD 1B, 2B and CJ2 are to contactors, with proper arc suppressors across them, controlling the appropriate listed function to the right.

**Aux outputs 5 and 6 available with Multibox. Aux outputs 5 to 6 available with Multibox disabled.

Section 4 – Optional Wiring Tables (Continued)

TABLE 1(d)

Crane Control Type Selection:

10KS1202P7, 10K Stepless Hoist, 2-Speed Trolley and Bridge

TYPE 3 PROGRAMMING

ACCO CONTROLS: TROLLEY and BRIDGE

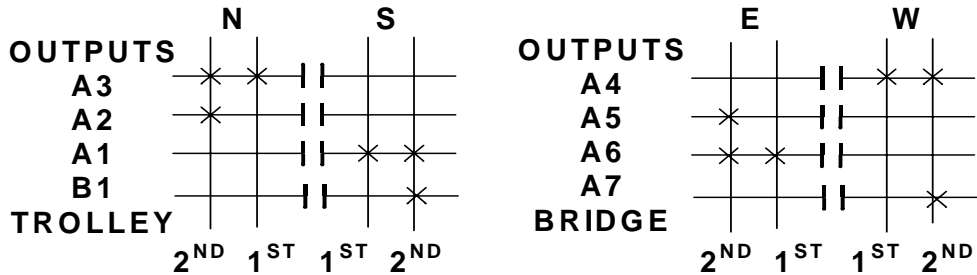

INDEPENDENT OUTPUTS

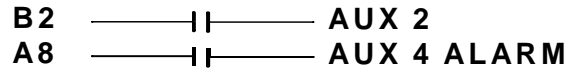

STANDARD OUTPUTS	STANDARD OUTPUTS	OPTIONAL OUTPUT BOARD OPTION #1	OPTIONAL OUTPUT BOARD OPTION #2
A1 TROLLEY SOUTH	B1 TROLLEY 2 ND SPD S	C1 AUX 5	C1 AUX 5
A2 TROLLEY 2 ND SPD N	B2 AUX 2 (LATCHABLE S2-7)	C2 AUX 6	C2 AUX 6
A3 TROLLEY NORTH	B3 HOIST UP	C3 MULTIBOX 1	C3
A4 BRIDGE WEST	B4 HOIST DOWN	C4 MULTIBOX 2	C4
A5 BRIDGE 2 ND SPD E		C5 MULTIBOX 3	C5
A6 BRIDGE EAST		C6 MULTIBOX 4	C6
A7 BRIDGE 2 ND SPD W			
A8 AUX 4 (ALARM)			

NOTE: To use Optional Receiver Output Board, the Optional Output board must be installed and connected. With the Optional Output Board installed, Receiver Switch Sw3-3 must "ON" for Output Option #1 and "OFF" for Output Option #2.

Transmitter Switch Select: "D" Switch settings Sw4-5 to Sw4-7 are defined as follows :

TRANSMITTER SWITCH SETTINGS:

TYPE	Sw4-7	Sw4-6	Sw4-5
3	OFF	ON	ON

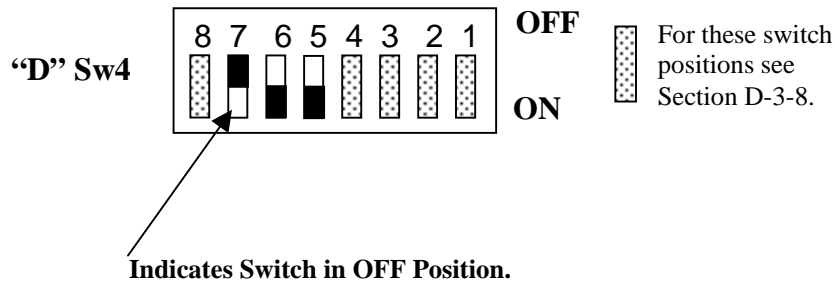

Section 4 – Optional Wiring Tables (Continued)

TABLE 1(e)

**Crane Control Type Selection:
10KS1202P7, 10K Stepless Hoist, 2-Speed Trolley and Bridge**

TYPE 4 WIRING DIAGRAM
P&H: TROLLEY and BRIDGE

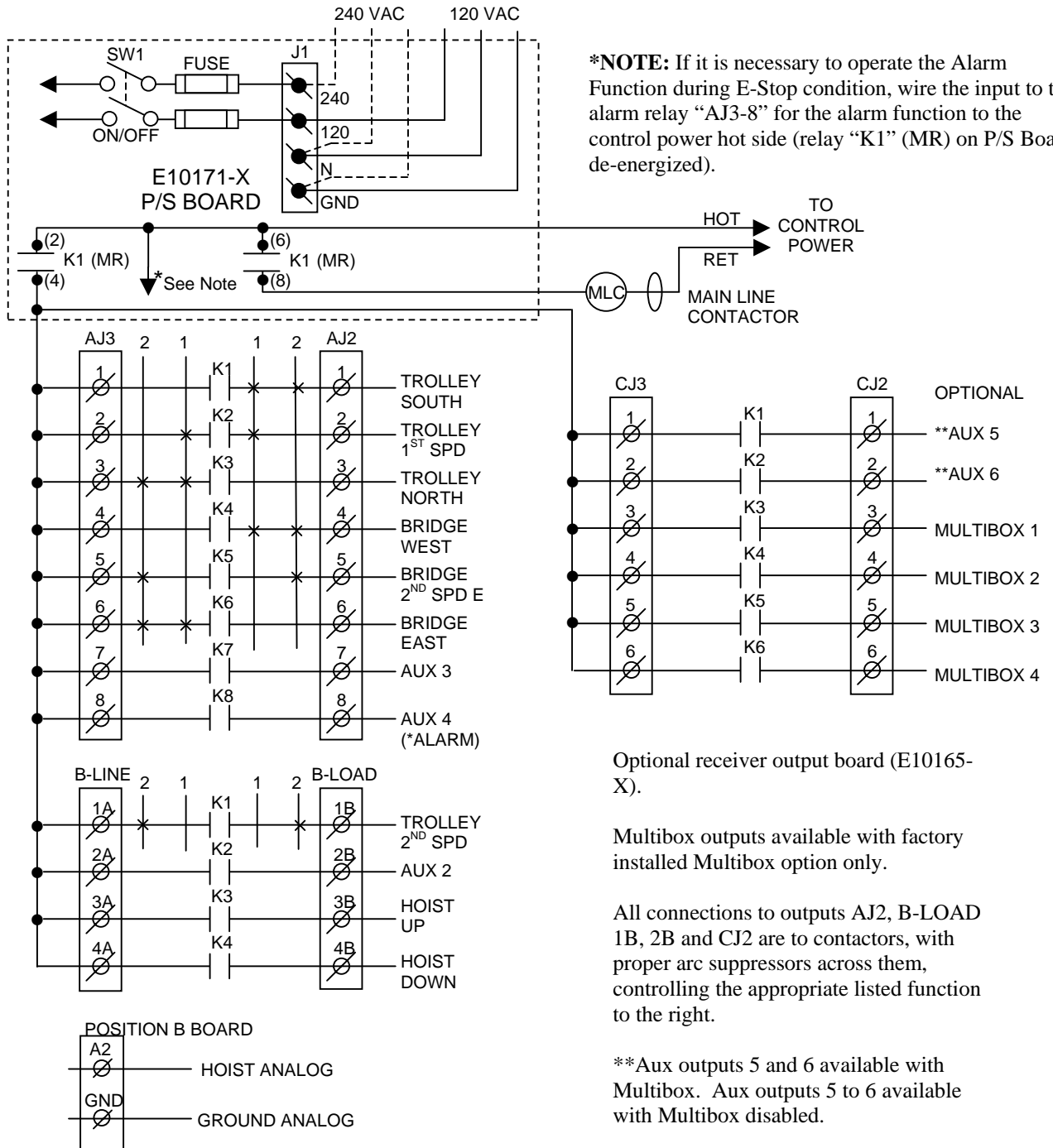

Section 4 – Optional Wiring Tables (Continued)

TABLE 1(e)

**Crane Control Type Selection:
10KS1202P7, 10K Stepless Hoist, 2-Speed Trolley and Bridge**

TYPE 4 PROGRAMMING
P&H: TROLLEY and BRIDGE

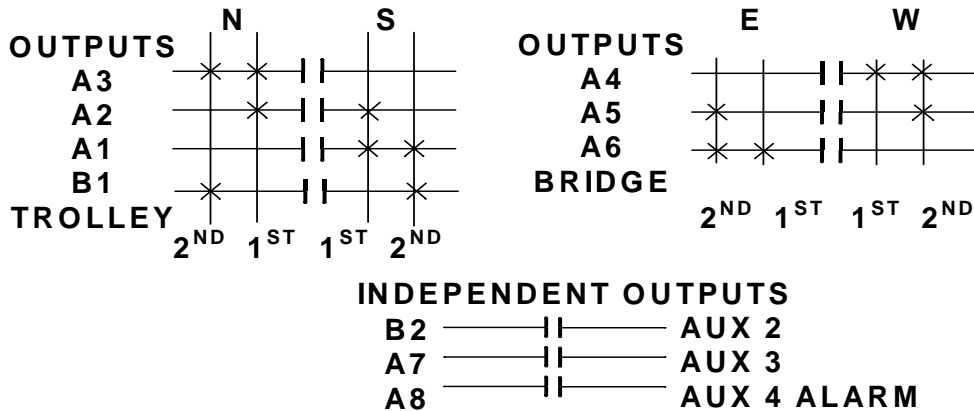

STANDARD OUTPUTS	OPTIONAL OUTPUT OUTPUTS	OPTIONAL OUTPUT BOARD OPTION #1	BOARD OPTION #2
A1 TROLLEY SOUTH	B1 TROLLEY 2 ND SPD	C1 AUX 5	C1 AUX 5
A2 TROLLEY 1 ST SPD	B2 AUX 2 (LATCHABLE S2-7)	C2 AUX 6	C2 AUX 6
A3 TROLLEY NORTH	B3 HOIST UP	C3 MULTIBOX 1	C3
A4 BRIDGE WEST	B4 HOIST DOWN	C4 MULTIBOX 2	C4
A5 BRIDGE 2 ND SPD		C5 MULTIBOX 3	C5
A6 BRIDGE EAST		C6 MULTIBOX 4	C6
A7 AUX 3 (LATCHABLE S2-6)			
A8 AUX 4 (ALARM)			

NOTE: To use Optional Receiver Output Board, the Optional Output board must be installed and connected. With the Optional Output Board installed, Receiver Switch Sw3-3 must “ON” for Output Option #1 and “OFF” for Output Option #2.

Transmitter Switch Select: “D” Switch settings Sw4-5 to Sw4-7 are defined as follows :

TRANSMITTER SWITCH SETTINGS: TYPE Sw4-7 Sw4-6 Sw4-5
4 ON OFF OFF

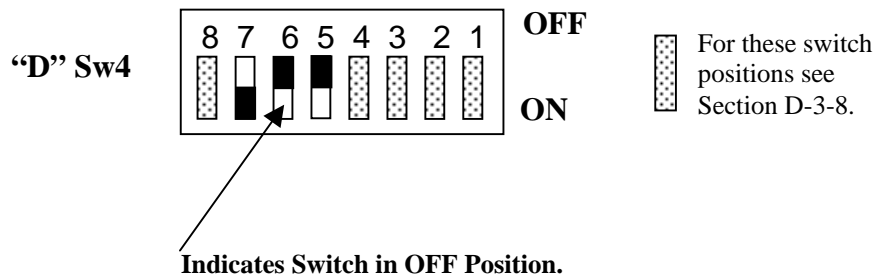

Section 4 – Optional Wiring Tables (Continued)

TABLE 2(a)

**Crane Control Type Selection:
10KS1220P7, 10K Stepless Bridge and Trolley, 2-Speed Hoist**

TYPE 0 WIRING DIAGRAM

STANDARD CONFIGURATION:

STEPPED HOIST, STEPLESS. TROLLEY and BRIDGE

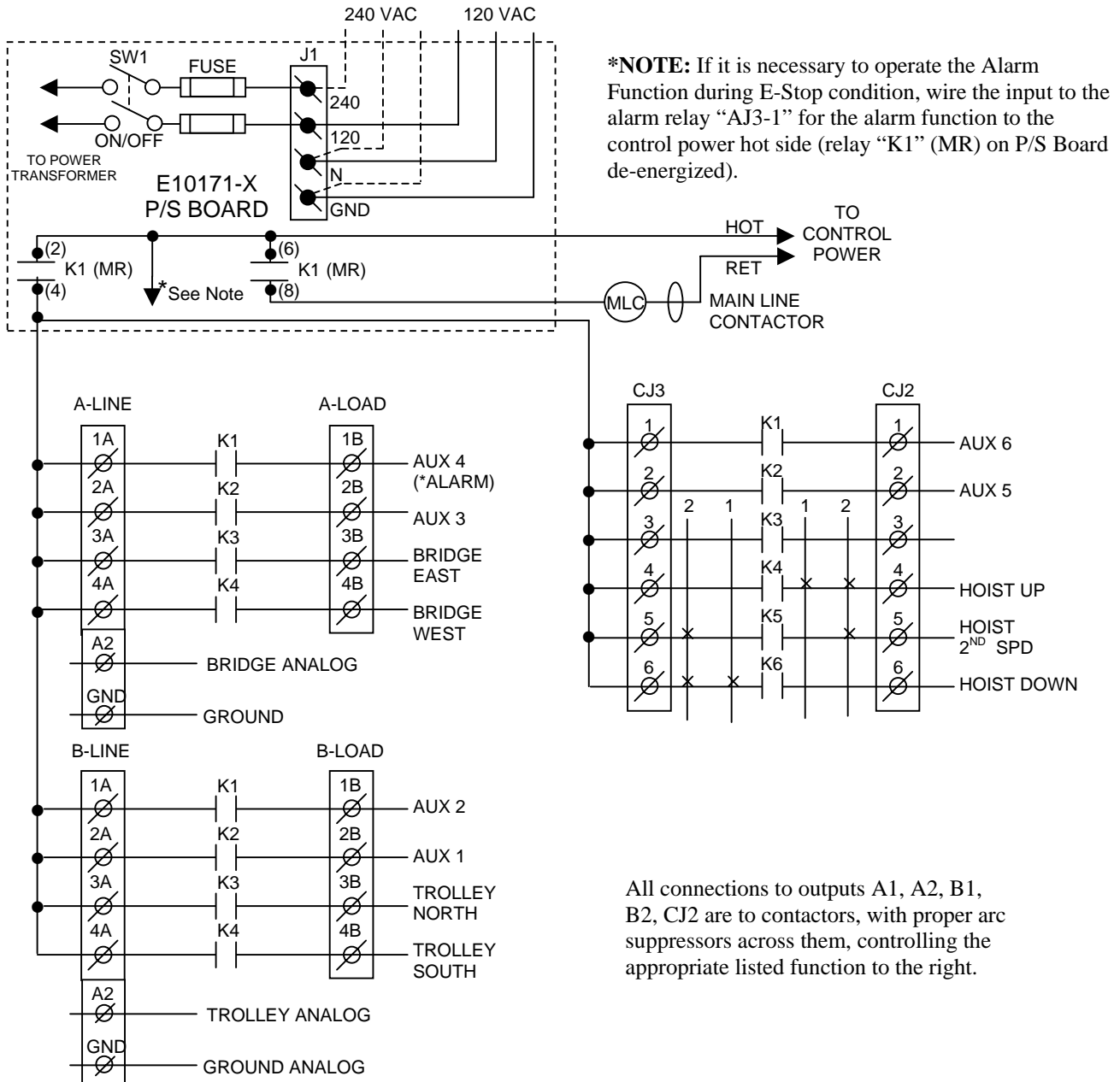

Section 4 – Optional Wiring Tables (Continued)

TABLE 2(a)

**Crane Control Type Selection:
10KS1220P7, 10K Stepless Bridge and Trolley, 2-Speed Hoist**

TYPE 0 PROGRAMMING

STANDARD CONFIGURATION:

STEPPED HOIST, STEPLESS. TROLLEY and BRIDGE

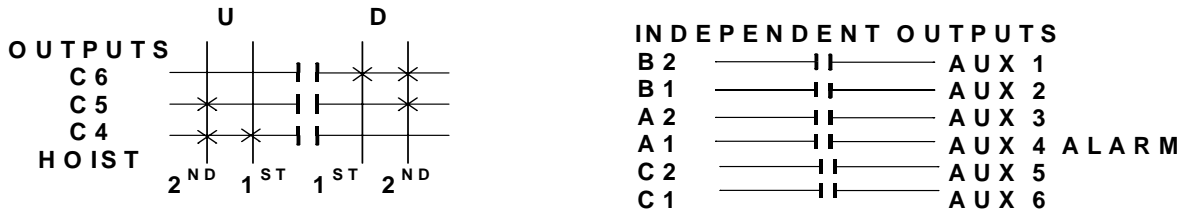

OUTPUT DEFINITIONS

HOIST

- C6 HOIST DOWN
- C5 HOIST 2ND SPEED
- C4 HOIST UP

INDEPENDENT OUTPUTS

- B2 AUX 1 (LATCHABLE S2-8)
- B1 AUX 2 (LATCHABLE S2-7)
- A2 AUX 3 (LATCHABLE S2-6)
- A1 AUX 4 (ALARM)
- C2 AUX 5
- C1 AUX 6

Transmitter Switch Select: "D" Switch settings Sw4-5 to Sw4-7 are defined as :

TRANSMITTER SWITCH SETTINGS: TYPE	Sw4-7	Sw4-6	Sw4-5
	0	OFF	OFF

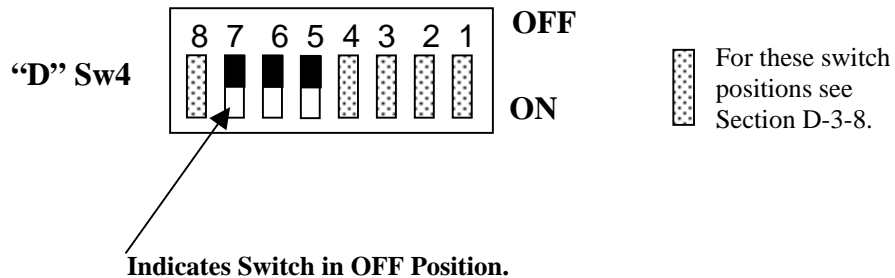

Section 4 – Optional Wiring Tables (Continued)

TABLE 2(b)

**Crane Control Type Selection:
10KS1220P7, 10K Stepless Bridge and Trolley, 2-Speed Hoist**

TYPE 1 WIRING DIAGRAM

2-SPD WITH DIRECTIONAL CONTROL: HOIST

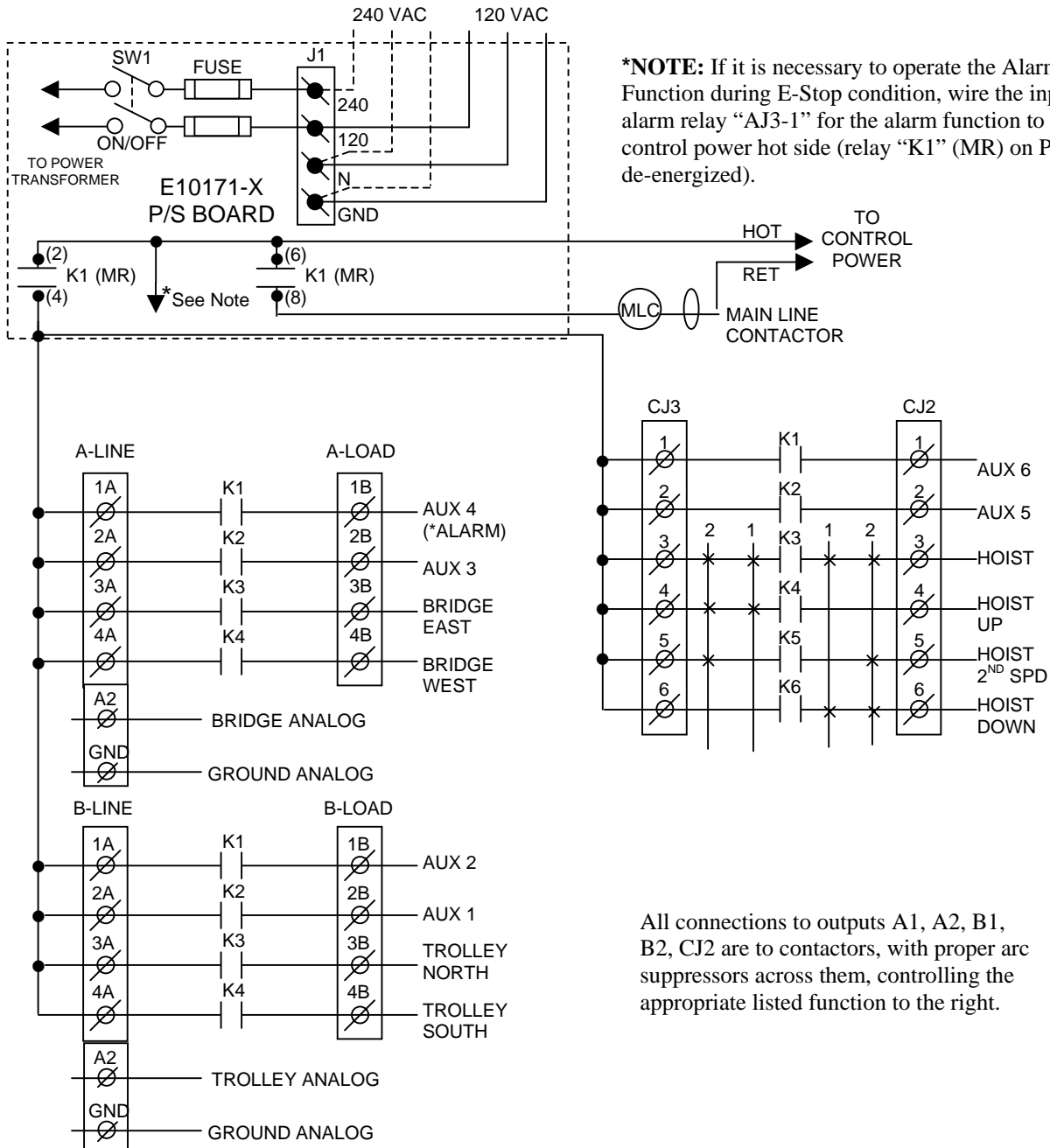

***NOTE:** If it is necessary to operate the Alarm Function during E-Stop condition, wire the input to the alarm relay “AJ3-1” for the alarm function to the control power hot side (relay “K1” (MR) on P/S Board de-energized).

All connections to outputs A1, A2, B1, B2, CJ2 are to contactors, with proper arc suppressors across them, controlling the appropriate listed function to the right.

Section 4 – Optional Wiring Tables (Continued)

TABLE 2(b)

Crane Control Type Selection:
10KS1220P7, 10K Stepless Bridge and Trolley, 2-Speed Hoist
TYPE 1 PROGRAMMING
2-SPD WITH DIRECTIONAL CONTROL: HOIST

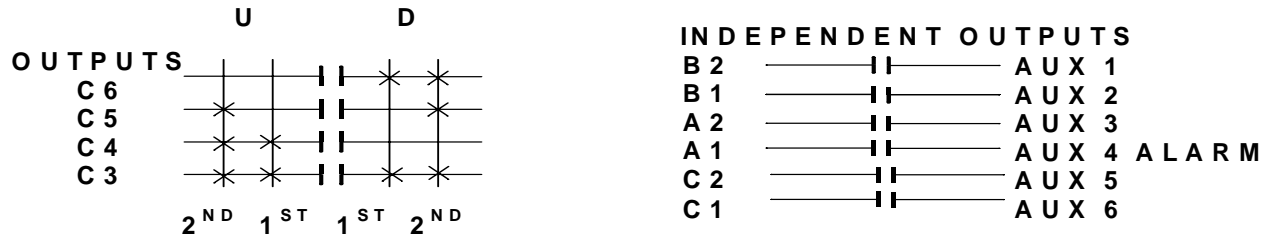

OUTPUT DEFINITIONS

HOIST

- C6 HOIST DOWN
- C5 HOIST 2ND SPEED
- C4 HOIST UP
- C3 HOIST

INDEPENDENT OUTPUTS

- B2 AUX 1 (LATCHABLE S2-8)
- B1 AUX 2 (LATCHABLE S2-7)
- A2 AUX 3 (LATCHABLE S2-6)
- A1 AUX 4 (ALARM)
- C2 AUX 5
- C1 AUX 6

Transmitter Switch Select: "D" Switch settings Sw4-5 to Sw4-7 are defined as follows :

TRANSMITTER SWITCH SETTINGS: TYPE Sw4-7 Sw4-6 Sw4-5
0 OFF OFF ON

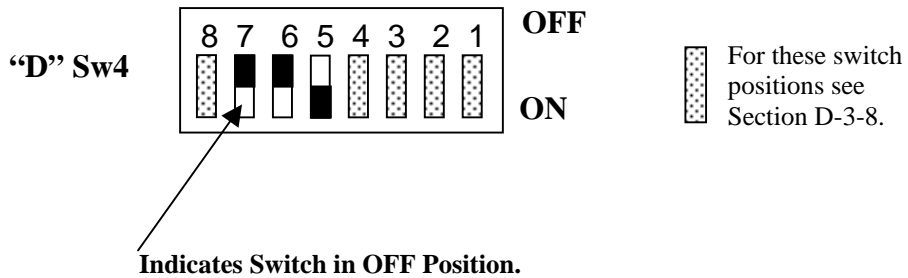

Section 4 – Optional Wiring Tables (Continued)

TABLE 2(c)

**Crane Control Type Selection:
10KS1220P7, 10K Stepless Bridge and Trolley, 2-Speed Hoist**

TYPE 2 WIRING DIAGRAM
2-SPEED, 2-WINDINGS: HOIST

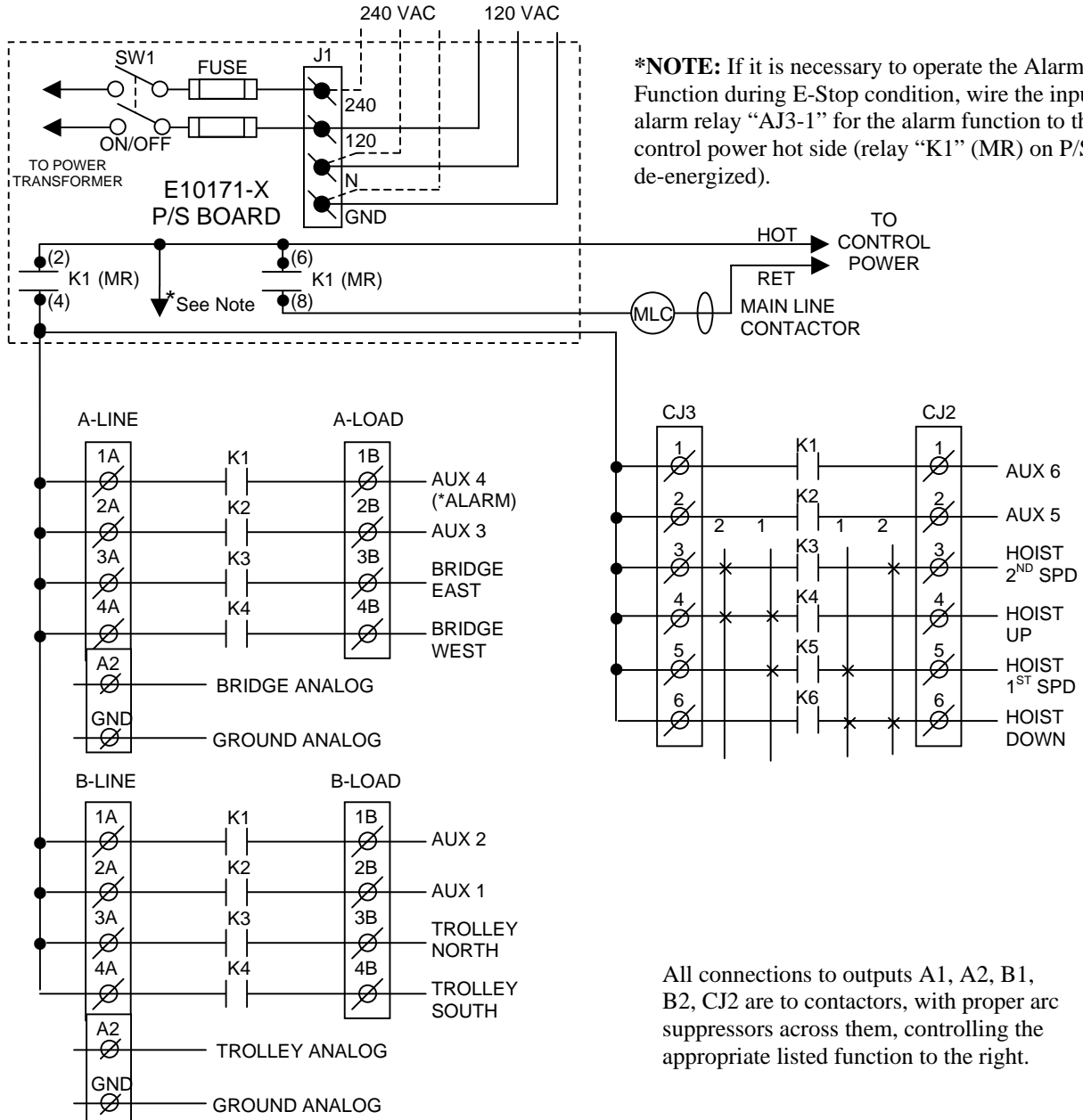

Section 4 – Optional Wiring Tables (Continued)

TABLE 2(c)

**Crane Control Type Selection:
10KS1220P7, 10K Stepless Bridge and Trolley, 2-Speed Hoist**

TYPE 2 PROGRAMMING
2-SPEED, 2-WINDINGS: HOIST

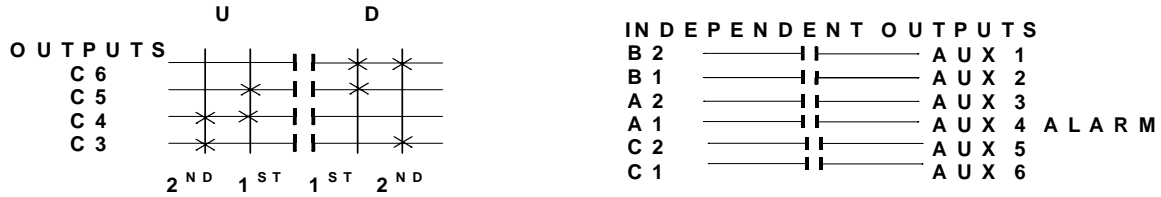

OUTPUT DEFINITIONS

HOIST

- C6 HOIST DOWN
- C5 HOIST 1ST SPEED
- C4 HOIST UP
- C3 HOIST 2ND SPEED

I N D E P E N D E N T O U T P U T S

- B2 AUX 1 (LATCHABLE S2-8)
- B1 AUX 2 (LATCHABLE S2-7)
- A2 AUX 3 (LATCHABLE S2-6)
- A1 AUX 4 (ALARM)
- C2 AUX 5
- C1 AUX 6

Transmitter Switch Select: "D" Switch settings Sw4-5 to Sw4-7 are defined as follows :

TRANSMITTER SWITCH SETTINGS: TYPE	Sw4-7	Sw4-6	Sw4-5
	2	OFF	ON
		ON	OFF

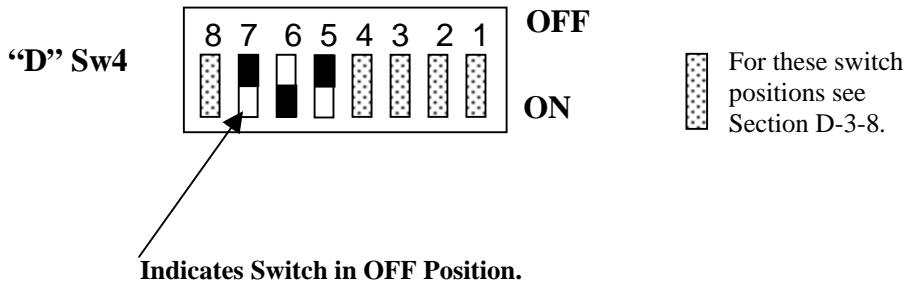

Section 4 – Optional Wiring Tables (Continued)

TABLE 2(d)

**Crane Control Type Selection:
10KS1220P7, 10K Stepless Bridge and Trolley, 2-Speed Hoist
TYPE 3 WIRING DIAGRAM
DEMAG and ACCO CONTROLS: HOIST**

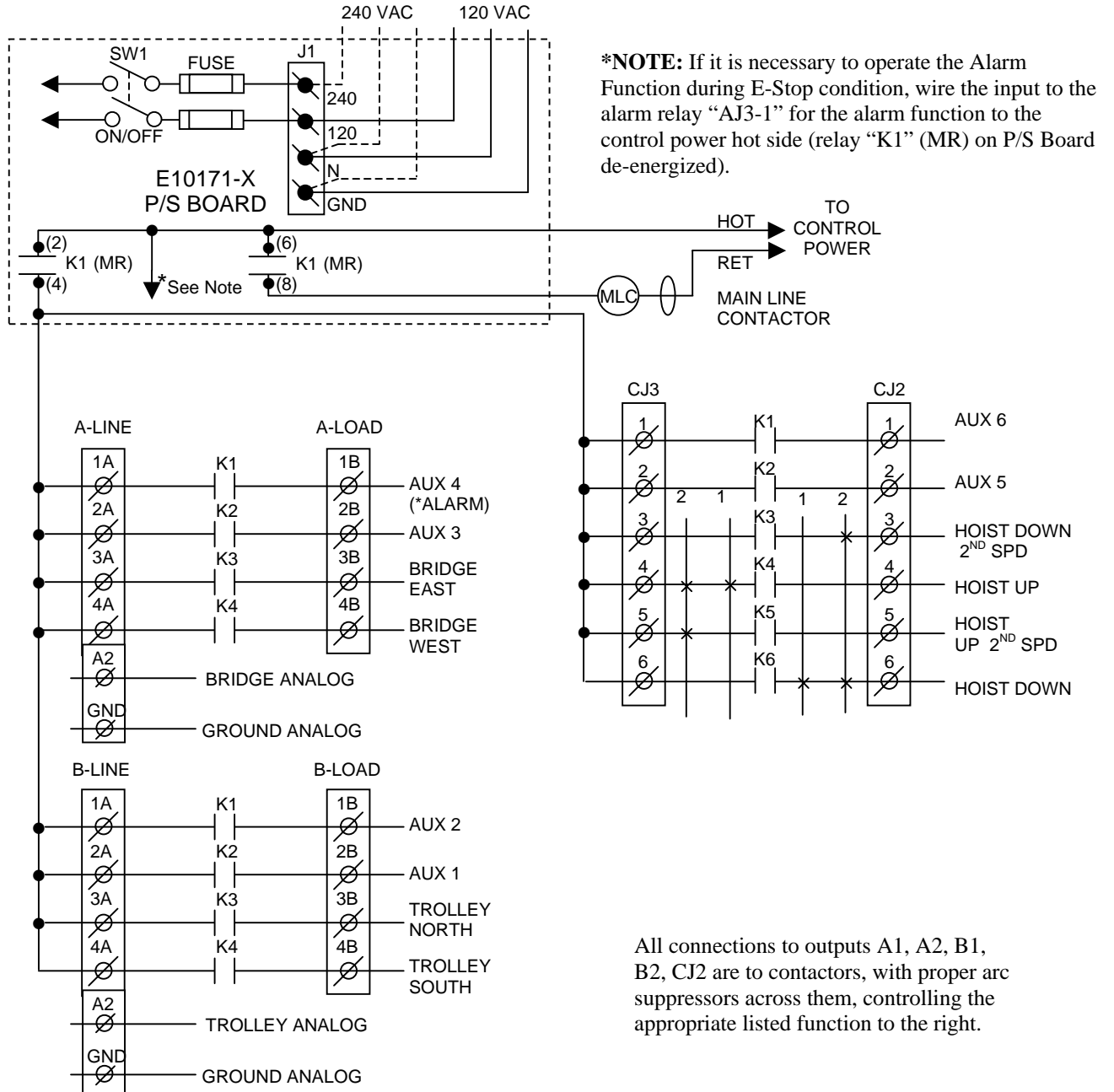

Section 4 – Optional Wiring Tables (Continued)

TABLE 2(d)

Crane Control Type Selection:
10KS1220P7, 10K Stepless Bridge and Trolley, 2-Speed Hoist
TYPE 3 PROGRAMMING
DEMAG and ACCO CONTROLS: HOIST

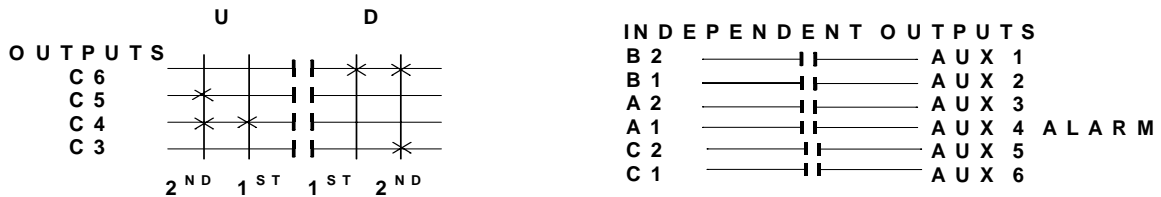

OUTPUT DEFINITIONS

HOIST

- C6 HOIST DOWN
- C5 HOIST 2ND SPEED UP
- C4 HOIST UP
- C3 HOIST 2ND SPEED DOWN

INDEPENDENT OUTPUTS

- B2 AUX 1 (LATCHABLE S2-8)
- B1 AUX 2 (LATCHABLE S2-7)
- A2 AUX 3 (LATCHABLE S2-6)
- A1 AUX 4 (ALARM)
- C2 AUX 5
- C1 AUX 6

Transmitter Switch Select: "D" Switch settings Sw4-5 to Sw4-7 are defined as follows :

TRANSMITTER SWITCH SETTINGS: TYPE	Sw4-7	Sw4-6	Sw4-5
	3	OFF	ON ON

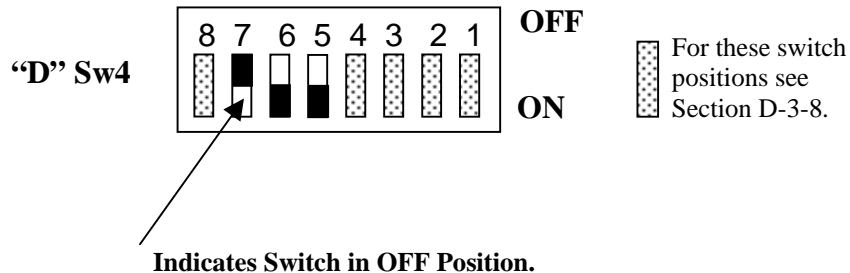

Section 3 – Operation and Setup (Continued)

TABLE 3(a)

**Crane Control Type Selection:
10KS1221P7, 10K Stepless Bridge, 2-Speed Hoist and Trolley**

TYPE 0 WIRING DIAGRAM

STANDARD CONFIGURATION:

STEPLESS BRIDGE, 2-SPD. HOIST and TROLLEY

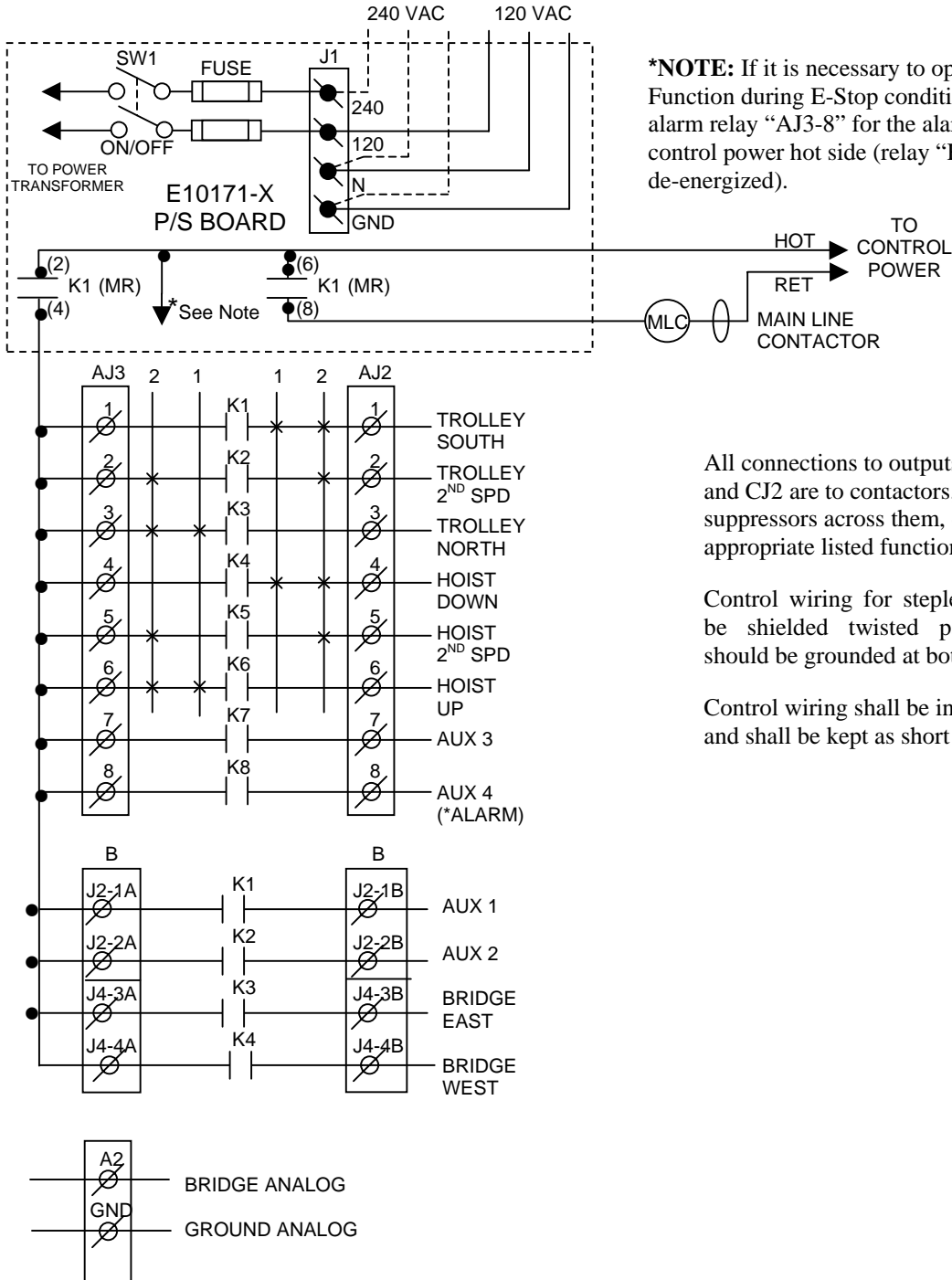

***NOTE:** If it is necessary to operate the Alarm Function during E-Stop condition, wire the input to the alarm relay “AJ3-8” for the alarm function to the control power hot side (relay “K1” (MR) on P/S Board de-energized).

All connections to outputs AJ2, 1B, 2B and CJ2 are to contactors, with proper arc suppressors across them, controlling the appropriate listed function to the right.

Control wiring for stepless devices shall be shielded twisted pair. The shield should be grounded at both ends

Control wiring shall be in separate conduit and shall be kept as short as possible.

Section 4 – Optional Wiring Tables (Continued)

TABLE 3(a)

**Crane Control Type Selection:
10KS1221P7, 10K Stepless Bridge, 2-Speed Hoist and Trolley**

TYPE 0 PROGRAMMING

STANDARD CONFIGURATION:

STEPLESS BRIDGE, 2-SPD. HOIST and TROLLEY

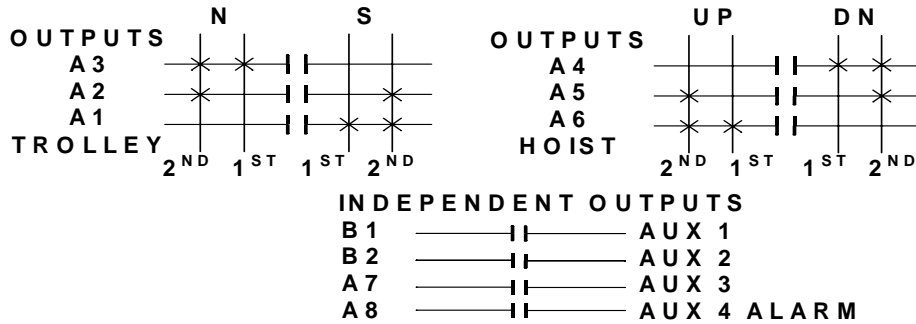

**STANDARD
OUTPUTS**

- A1 TROLLEY SOUTH
- A2 TROLLEY 2ND SPEED
- A3 TROLLEY NORTH
- A4 HOIST DOWN
- A5 HOIST 2ND SPEED
- A6 HOIST UP
- A7 AUX 3 (LATCHABLE S2-6)
- A8 AUX 4 (ALARM)

**STANDARD
OUTPUTS**

- B1 AUX 1 (LATCHABLE S2-8)
- B2 AUX 2 (LATCHABLE S2-7)
- B3 BRIDGE EAST
- B4 BRIDGE WEST

Transmitter Switch Select: "D" Switch settings Sw4-5 to Sw4-7 are defined as follows:

TRANSMITTER SWITCH SETTINGS:

TYPE	Sw4-7	Sw4-6	Sw4-5
0	OFF	OFF	OFF

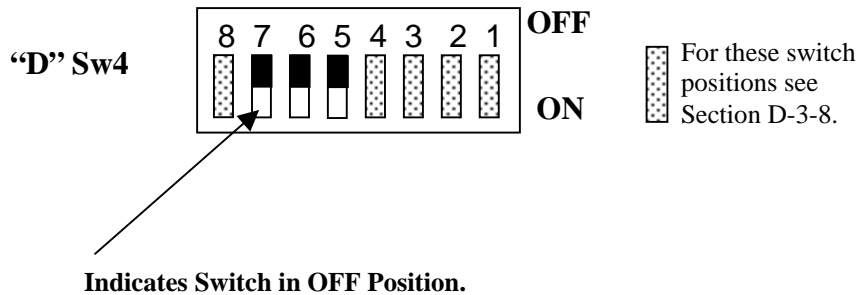

Section 4 – Optional Wiring Tables (Continued)

TABLE 3(b)

Crane Control Type Selection:

10KS1221P7, 10K Stepless Bridge, 2-Speed Hoist and Trolley

TYPE 1 WIRING DIAGRAM

STEPLESS BRIDGE, TROLLEY and HOIST 2-SPD with DIRECTIONAL CONTROL

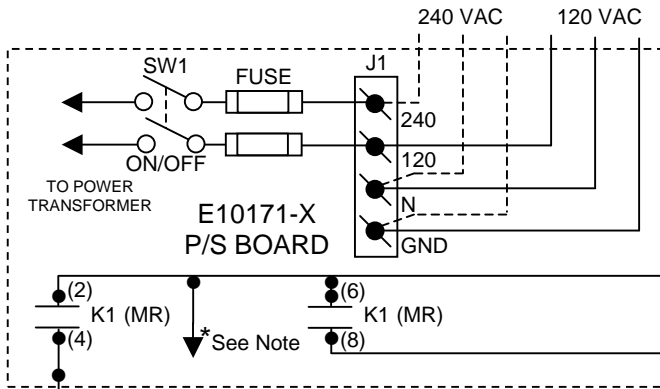

***NOTE:** If it is necessary to operate the Alarm Function during E-Stop condition, wire the input to the alarm relay “AJ3-8” for the alarm function to the control power hot side (relay “K1” (MR) on P/S Board de-energized).

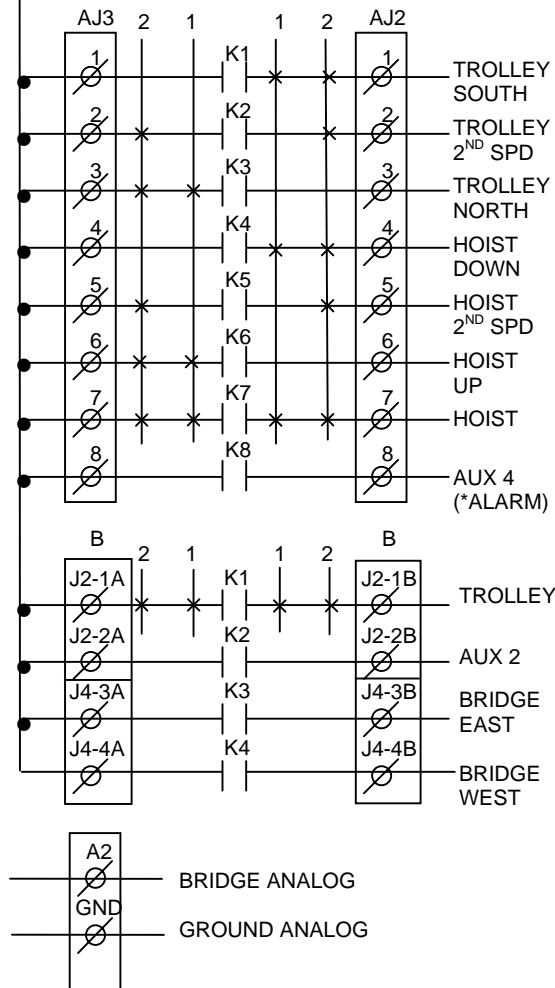

All connections to outputs AJ2, 1B, 2B and CJ2 are to contactors, with proper arc suppressors across them, controlling the appropriate listed function to the right.

Control wiring for stepless devices shall be shielded twisted pair. The shield should be grounded at both ends

Control wiring shall be in separate conduit and shall be kept as short as possible.

Section 4 – Optional Wiring Tables (Continued)

TABLE 3(b)

Crane Control Type Selection:

10KS1221P7, 10K Stepless Bridge, 2-Speed Hoist and Trolley

TYPE 1 PROGRAMMING

STEPLESS BRIDGE, TROLLEY and HOIST 2-SPD with DIRECTIONAL CONTROL

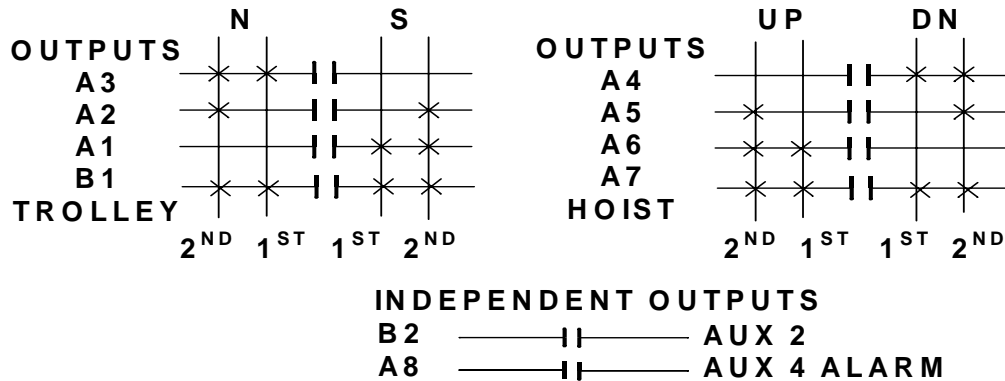

STANDARD OUTPUTS

- A1 TROLLEY SOUTH
- A2 TROLLEY 2ND SPEED
- A3 TROLLEY NORTH
- A4 HOIST DOWN
- A5 HOIST 2ND SPEED
- A6 HOIST UP
- A7 HOIST
- A8 AUX 4 (ALARM)

STANDARD OUTPUTS

- B1 TROLLEY
- B2 AUX 2 (LATCHABLE S2-7)
- B3 BRIDGE EAST
- B4 BRIDGE WEST

Transmitter Switch Select: “D” Switch settings Sw4-5 to Sw4-7 are defined as follows:

TRANSMITTER SWITCH SETTINGS:	TYPE	Sw4-7	Sw4-6	Sw4-5
	1	OFF	OFF	ON

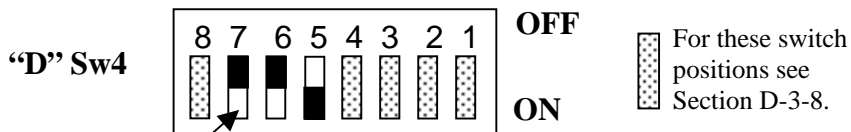

Indicates Switch in OFF Position.

Section 4 – Optional Wiring Tables (Continued)

TABLE 3(c)

Crane Control Type Selection:

10KS1221P7, 10K Stepless Bridge, 2-Speed Hoist and Trolley

TYPE 2 WIRING DIAGRAM

STEPLESS BRIDGE, TROLLEY and HOIST: 2-SPEED, 2-WINDINGS

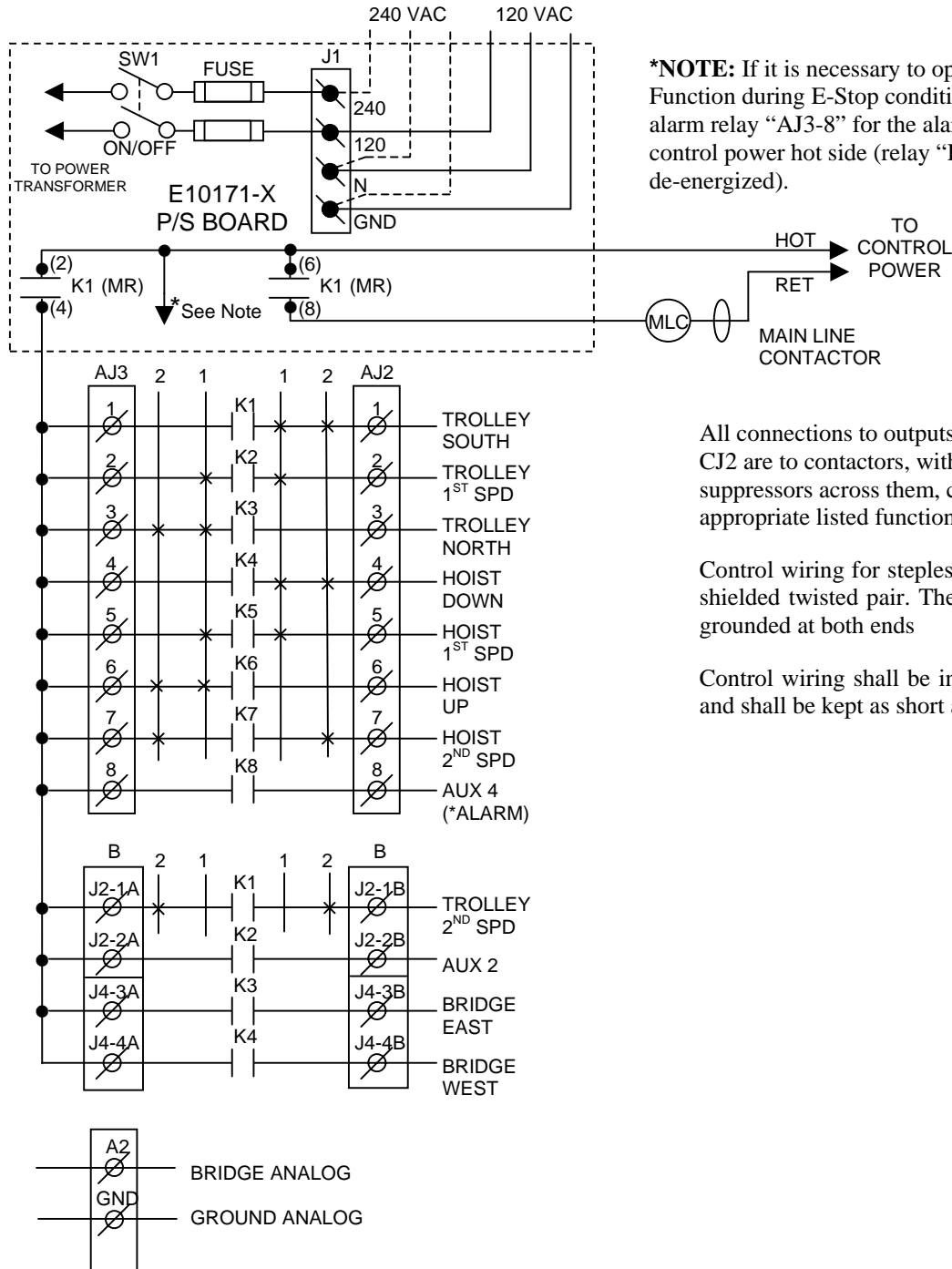

***NOTE:** If it is necessary to operate the Alarm Function during E-Stop condition, wire the input to the alarm relay “AJ3-8” for the alarm function to the control power hot side (relay “K1” (MR) on P/S Board de-energized).

All connections to outputs AJ2, 1B, 2B and CJ2 are to contactors, with proper arc suppressors across them, controlling the appropriate listed function to the right.

Control wiring for stepless devices shall be shielded twisted pair. The shield should be grounded at both ends

Control wiring shall be in separate conduit and shall be kept as short as possible.

Section 4 – Optional Wiring Tables (Continued)

TABLE 3(c)

Crane Control Type Selection:

10KS1221P7, 10K Stepless Bridge, 2-Speed Hoist and Trolley

TYPE 2 PROGRAMMING

STEPLESS BRIDGE, TROLLEY and HOIST: 2-SPEED, 2-WINDINGS

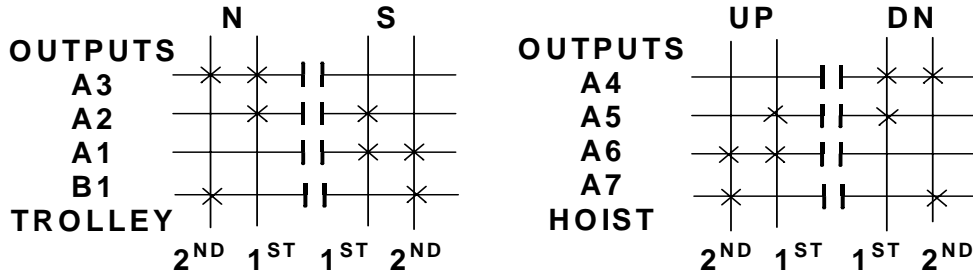

INDEPENDENT OUTPUTS

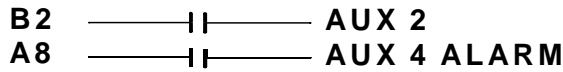

**STANDARD
OUTPUTS**

- A1 TROLLEY SOUTH
- A2 TROLLEY 1ST SPEED
- A3 TROLLEY NORTH
- A4 HOIST DOWN
- A5 HOIST 1ST SPEED
- A6 HOIST UP
- A7 HOIST 2ND SPD
- A8 AUX 4 (ALARM)

**STANDARD
OUTPUTS**

- B1 TROLLEY 2ND SPD
- B2 AUX 2 (LATCHABLE S2-7)
- B3 BRIDGE EAST
- B4 BRIDGE WEST

Transmitter Switch Select: "D" Switch settings Sw4-5 to Sw4-7 are defined as follows:

TRANSMITTER SWITCH SETTINGS:	TYPE	Sw4-7	Sw4-6	Sw4-5
	2	OFF	ON	OFF

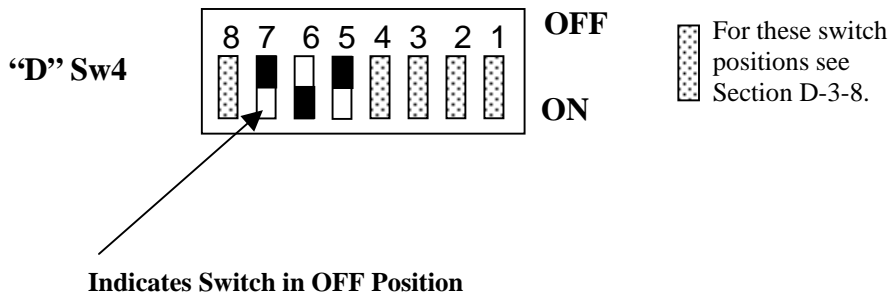

Section 4 – Optional Wiring Tables (Continued)

TABLE 3(d)

**Crane Control Type Selection:
10KS1221P7, 10K Stepless Bridge, 2-Speed Hoist and Trolley**

TYPE 3 WIRING DIAGRAM

ACCO CONTROLS: TROLLEY and HOIST with STEPLESS BRIDGE

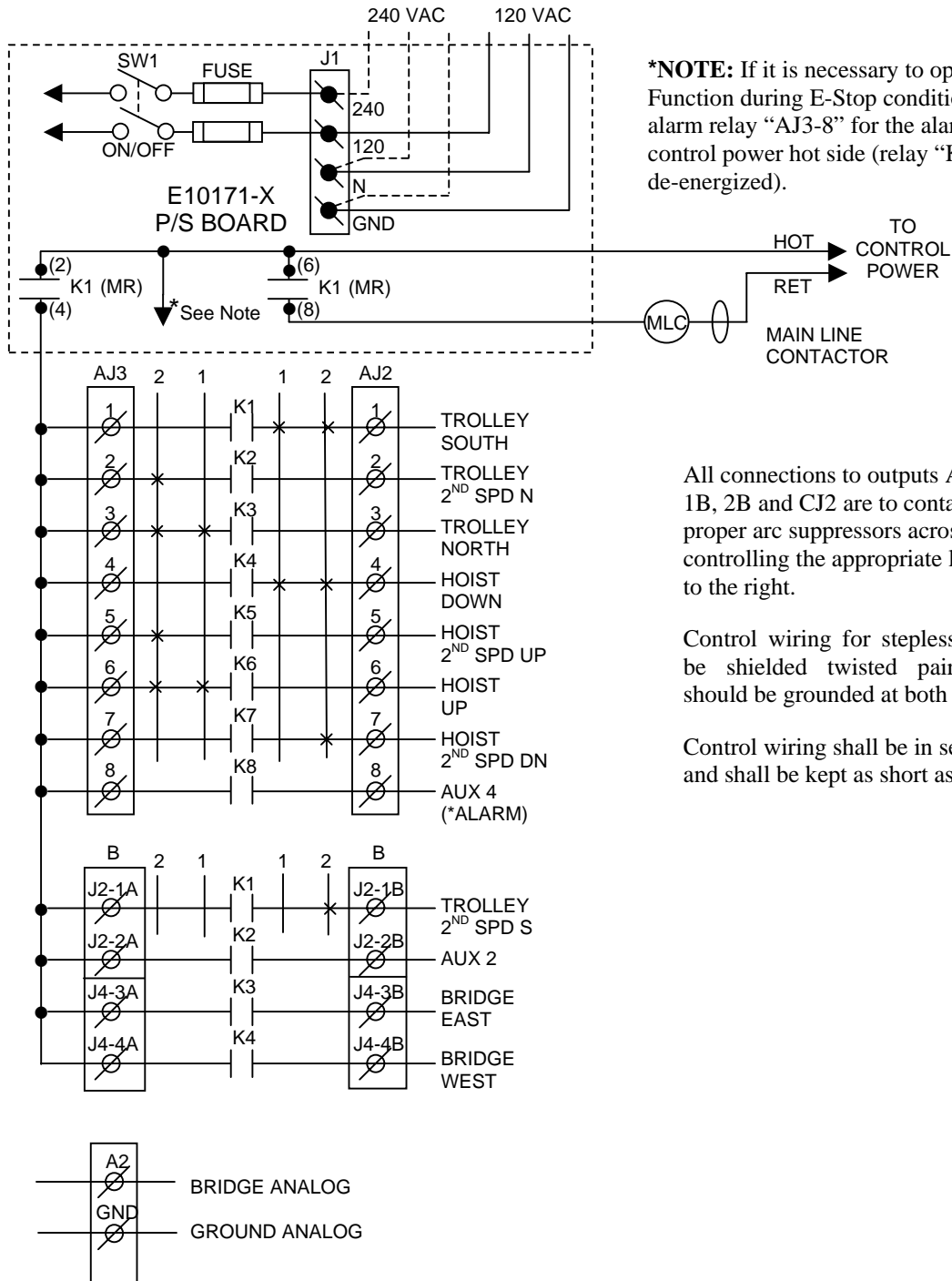

Section 4 – Optional Wiring Tables (Continued)

TABLE 3(d)

Crane Control Type Selection:

10KS1221P7, 10K Stepless Bridge, 2-Speed Hoist and Trolley

TYPE 3 PROGRAMMING

ACCO CONTROLS: TROLLEY and HOIST with STEPLESS BRIDGE

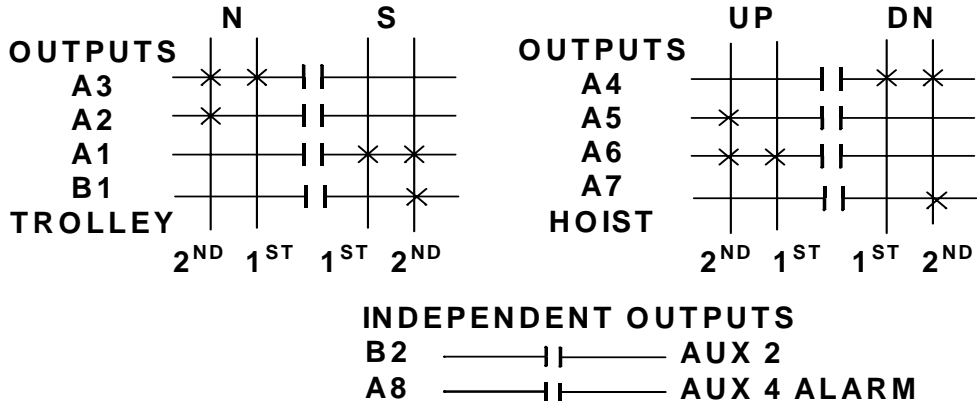

- STANDARD OUTPUTS**
- A1 TROLLEY SOUTH
 - A2 TROLLEY 2ND SPD N
 - A3 TROLLEY NORTH
 - A4 HOIST DOWN
 - A5 HOIST 2ND SPD DN
 - A6 HOIST UP
 - A7 HOIST 2ND SPD UP
 - A8 AUX 4 (ALARM)

- STANDARD OUTPUTS**
- B1 TROLLEY 2ND SPD S
 - B2 AUX 2 (LATCHABLE S2-7)
 - B3 BRIDGE EAST
 - B4 BRIDGE WEST

Transmitter Switch Select: "D" Switch settings Sw4-5 to Sw4-7 are defined as follows:

TRANSMITTER SWITCH SETTINGS:	TYPE	Sw4-7	Sw4-6	Sw4-5
	3	OFF	ON	ON

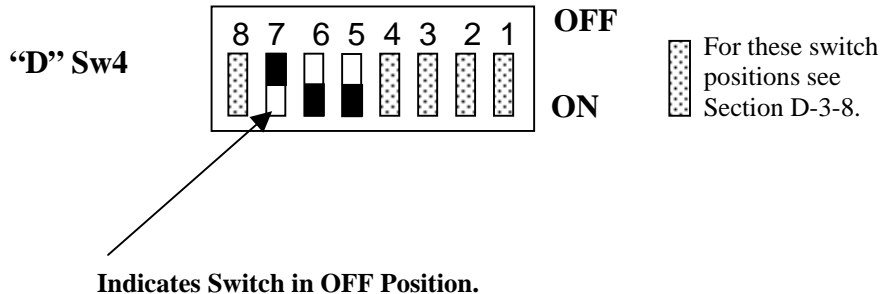

Section 4 – Optional Wiring Tables (Continued)

TABLE 3(e)

Crane Control Type Selection:

10KS1221P7, 10K Stepless Bridge, 2-Speed Hoist and Trolley

TYPE 4 WIRING DIAGRAM

P&H: 2-SPEED, 2-WINDINGS for HOIST, STANDARD TROLLEY
and STEPLESS BRIDGE

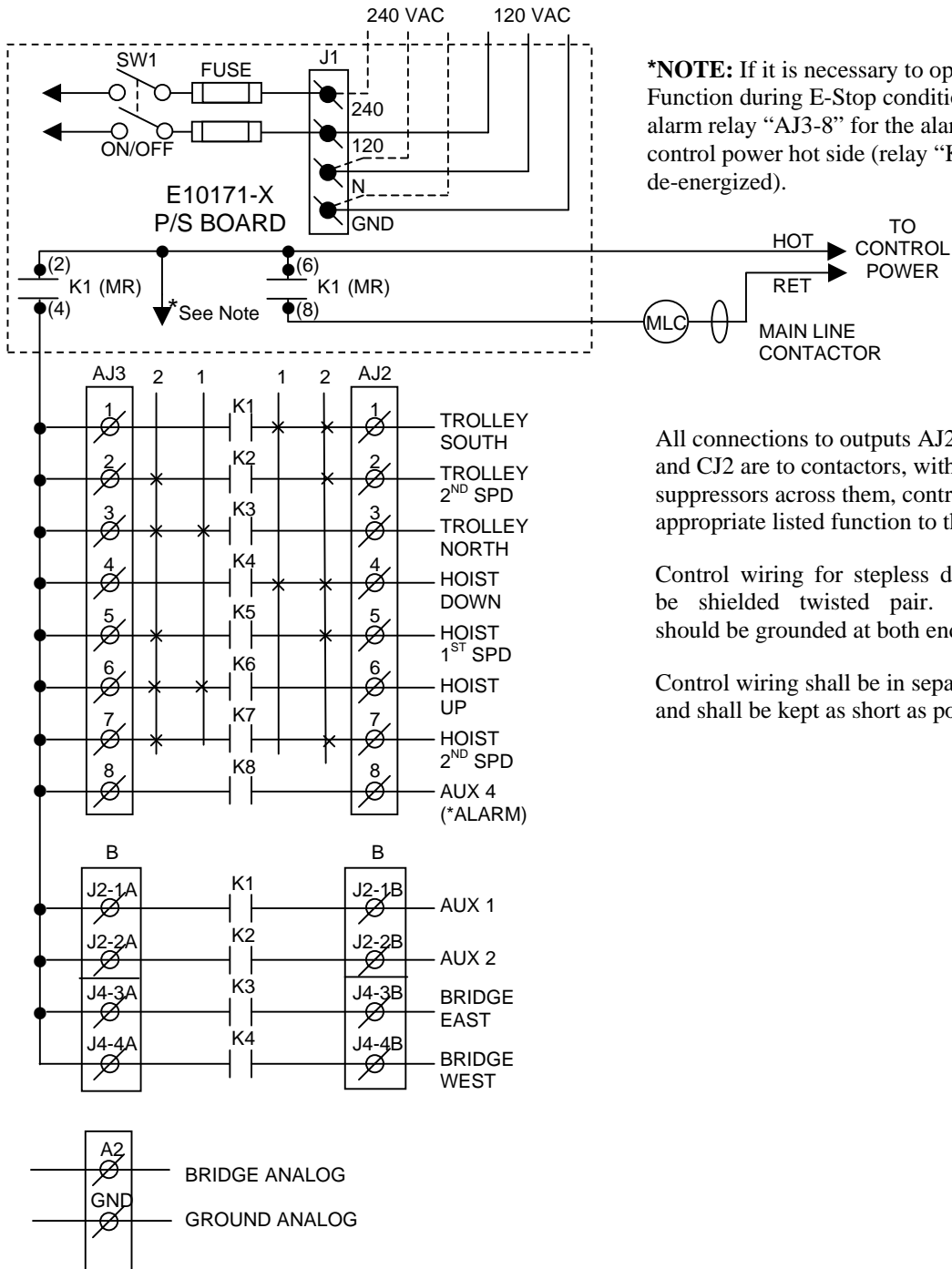

All connections to outputs AJ2, 1B, 2B and CJ2 are to contactors, with proper arc suppressors across them, controlling the appropriate listed function to the right.

Control wiring for stepless devices shall be shielded twisted pair. The shield should be grounded at both ends

Control wiring shall be in separate conduit and shall be kept as short as possible.

Section 4 – Optional Wiring Tables (Continued)

TABLE 3(e)

Crane Control Type Selection:

10KS1221P7, 10K Stepless Bridge, 2-Speed Hoist and Trolley

TYPE 4 PROGRAMMING

P&H: 2-SPEED, 2-WINDINGS for HOIST, STANDARD TROLLEY
and STEPLESS BRIDGE

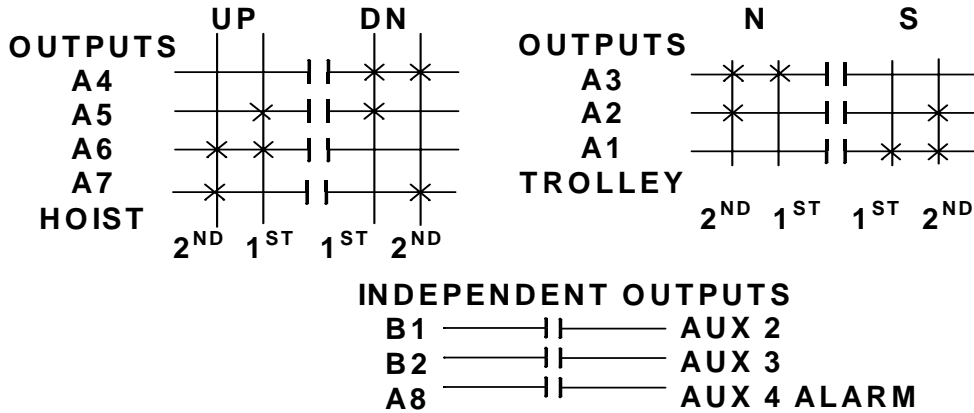

**STANDARD
OUTPUTS**

- A1 TROLLEY SOUTH
- A2 TROLLEY 2ND SPD
- A3 TROLLEY NORTH
- A4 HOIST DOWN
- A5 HOIST 1ST SPD
- A6 HOIST UP
- A7 HOIST 2ND SPD

**STANDARD
OUTPUTS**

- B1 AUX 1 (LATCHABLE S2-8)
- B2 AUX 2 (LATCHABLE S2-7)
- B3 BRIDGE EAST
- B4 BRIDGE WEST

Transmitter Switch Select: "D" Switch settings Sw4-5 to Sw4-7 are defined as follows:

TRANSMITTER SWITCH SETTINGS:

<i>TYPE</i>	<i>Sw4-7</i>	<i>Sw4-6</i>	<i>Sw4-5</i>
4	ON	OFF	OFF

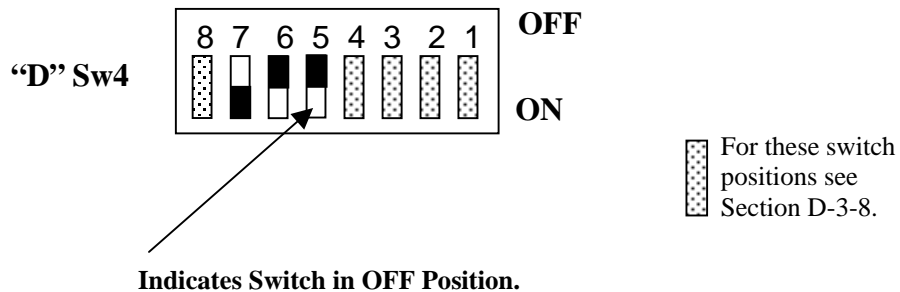

Section 4 – Optional Wiring Tables (Continued)

TABLE 3(f)

Crane Control Type Selection:

10KS1221P7, 10K Stepless Bridge, 2-Speed Hoist and Trolley

TYPE 5 WIRING DIAGRAM

**DEMAG: 2-SPEED, 2-WINDINGS for HOIST, STANDARD TROLLEY and
STEPLESS BRIDGE**

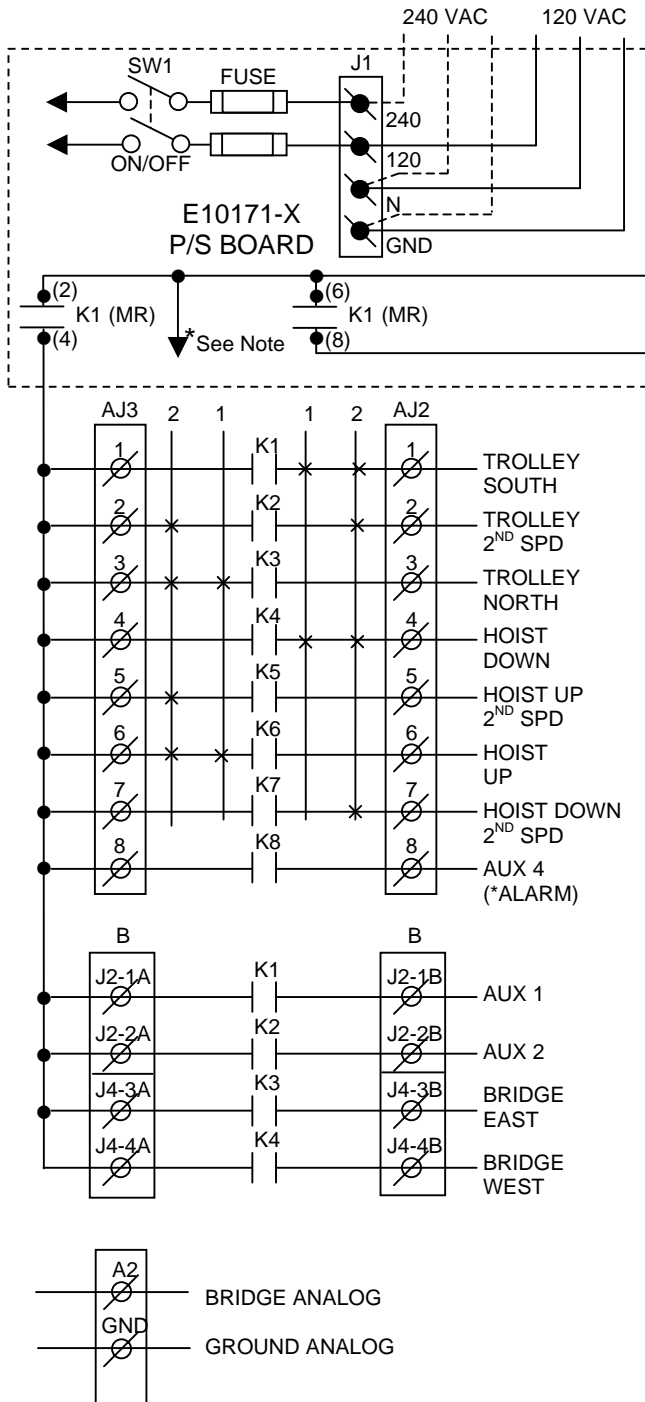

***NOTE:** If it is necessary to operate the Alarm Function during E-Stop condition, wire the input to the alarm relay “AJ3-8” for the alarm function to the control power hot side (relay “K1” (MR) on P/S Board de-energized).

All connections to outputs AJ2, 1B, 2B and CJ2 are to contactors, with proper arc suppressors across them, controlling the appropriate listed function to the right.

Control wiring for stepless devices shall be shielded twisted pair. The shield should be grounded at both ends

Control wiring shall be in separate conduit and shall be kept as short as possible.

Section 4 – Optional Wiring Tables (Continued)

TABLE 3(f)

Crane Control Type Selection:

10KS1221P7, 10K Stepless Bridge, 2-Speed Hoist and Trolley

TYPE 5 PROGRAMMING

DEMAG: 2-SPEED, 2-WINDINGS for HOIST, STANDARD TROLLEY and STEPLESS BRIDGE

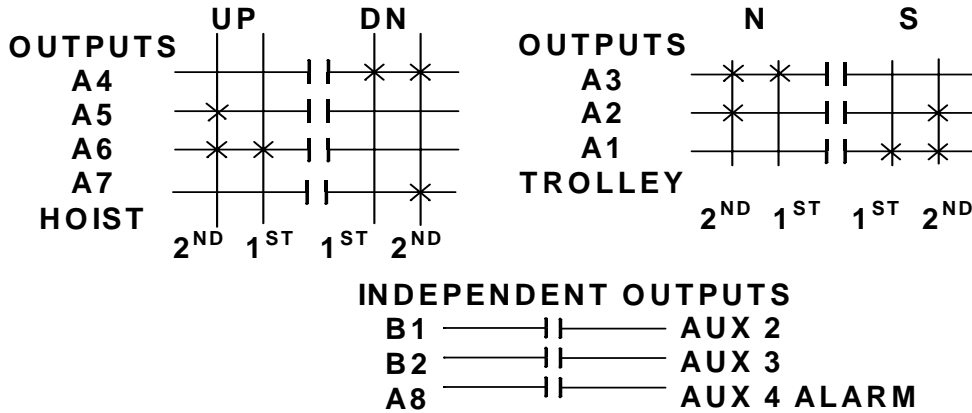

- STANDARD OUTPUTS**
- A1 TROLLEY SOUTH
 - A2 TROLLEY 1ST SPD
 - A3 TROLLEY NORTH
 - A4 HOIST DOWN
 - A5 HOIST 2ND SPD UP
 - A6 HOIST UP
 - A7 HOIST 2ND SPD DOWN
 - A8 AUX 4 (ALARM)

- STANDARD OUTPUTS**
- B1 AUX 1 (LATCHABLE S2-8)
 - B2 AUX 2 (LATCHABLE S2-7)
 - B3 BRIDGE EAST
 - B4 BRIDGE WEST

Transmitter Switch Select: "D" Switch settings Sw4-5 to Sw4-7 are defined as follows:

TRANSMITTER SWITCH SETTINGS:	TYPE	Sw4-7	Sw4-6	Sw4-5
	5	ON	OFF	OFF

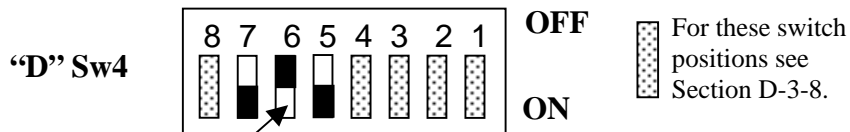

Indicates Switch in OFF Position.

Section 4 – Optional Wiring Tables (Continued)

TABLE 4(a)

**Crane Control Type Selection:
10KS1603P5, 10K Stepless Hoist, 3-Speed Trolley and Bridge**

TYPE 0 WIRING DIAGRAM

STANDARD CONFIGURATION:

STEPLESS HOIST, 3- SPEED TROLLEY and BRIDGE

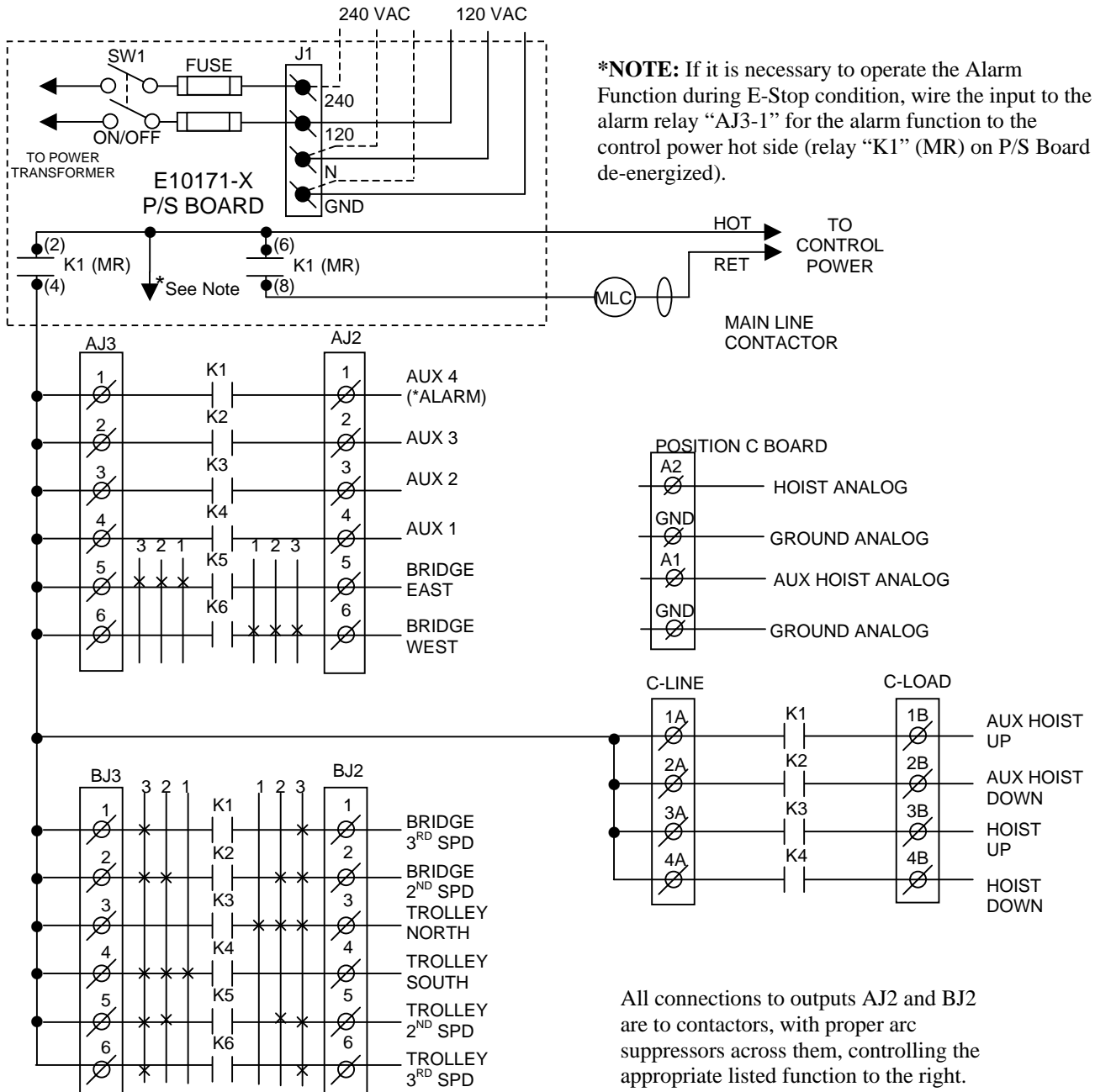

All connections to outputs AJ2 and BJ2 are to contactors, with proper arc suppressors across them, controlling the appropriate listed function to the right.

Section 4 – Optional Wiring Tables (Continued)

TABLE 4(a)

Crane Control Type Selection:

10KS1603P5, 10K Stepless Hoist, 3-Speed Trolley and Bridge

TYPE 0 PROGRAMMING

STANDARD CONFIGURATION:

STEPLESS HOIST, 3-SPEED TROLLEY and BRIDGE

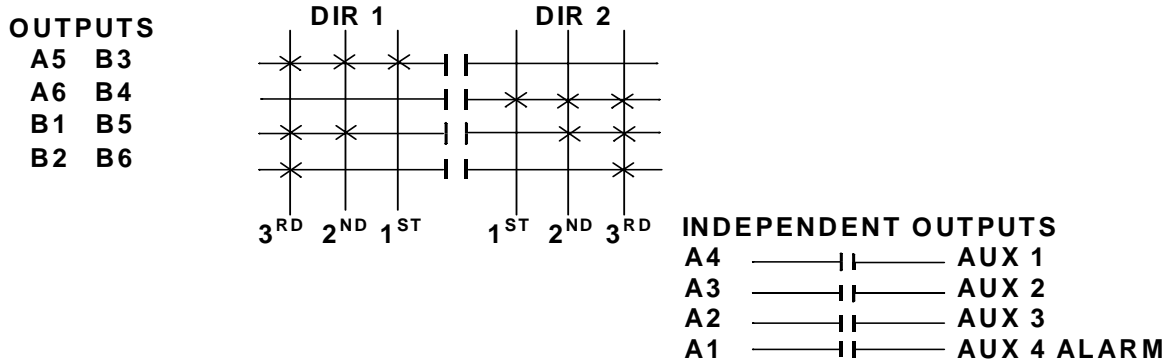

OUTPUT DEFINITIONS

BRIDGE

A5 EAST
A6 2ND SPEED
B1 WEST
B2 3RD SPEED

TROLLEY

B3 NORTH
B4 2ND SPEED
B5 SOUTH
B6 3RD SPEED

INDEPENDENT OUTPUTS

A1 AUX 4 (ALARM)
A2 AUX 3 (LATCHABLE S2-6)
A3 AUX 2 (LATCHABLE S2-7)
A4 AUX 1 (LATCHABLE S2-8)

Transmitter Switch Select: "D" Switch settings Sw4-5 to Sw4-7 are defined as follows:

TRANSMITTER SWITCH SETTINGS: TYPE	<i>Sw4-7</i>	<i>Sw4-6</i>	<i>Sw4-5</i>
0	OFF	OFF	OFF

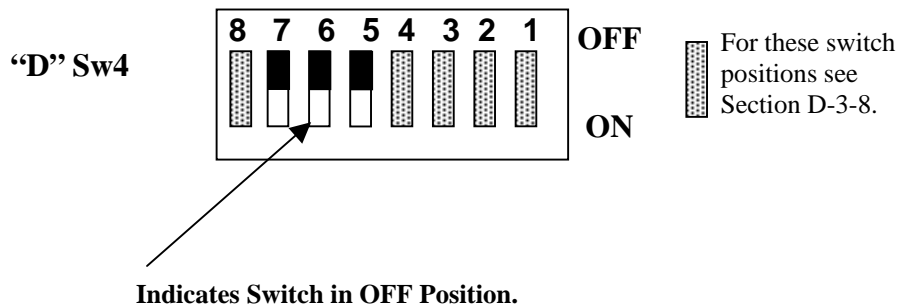

Section 4 – Optional Wiring Tables (Continued)

TABLE 4(b)

**Crane Control Type Selection:
10KS1603P5, 10K Stepless Hoist, 2-Speed Trolley and Bridge**

TYPE 1 WIRING DIAGRAM

2-SPEED with DIRECTIONAL CONTROLS: TROLLEY and BRIDGE

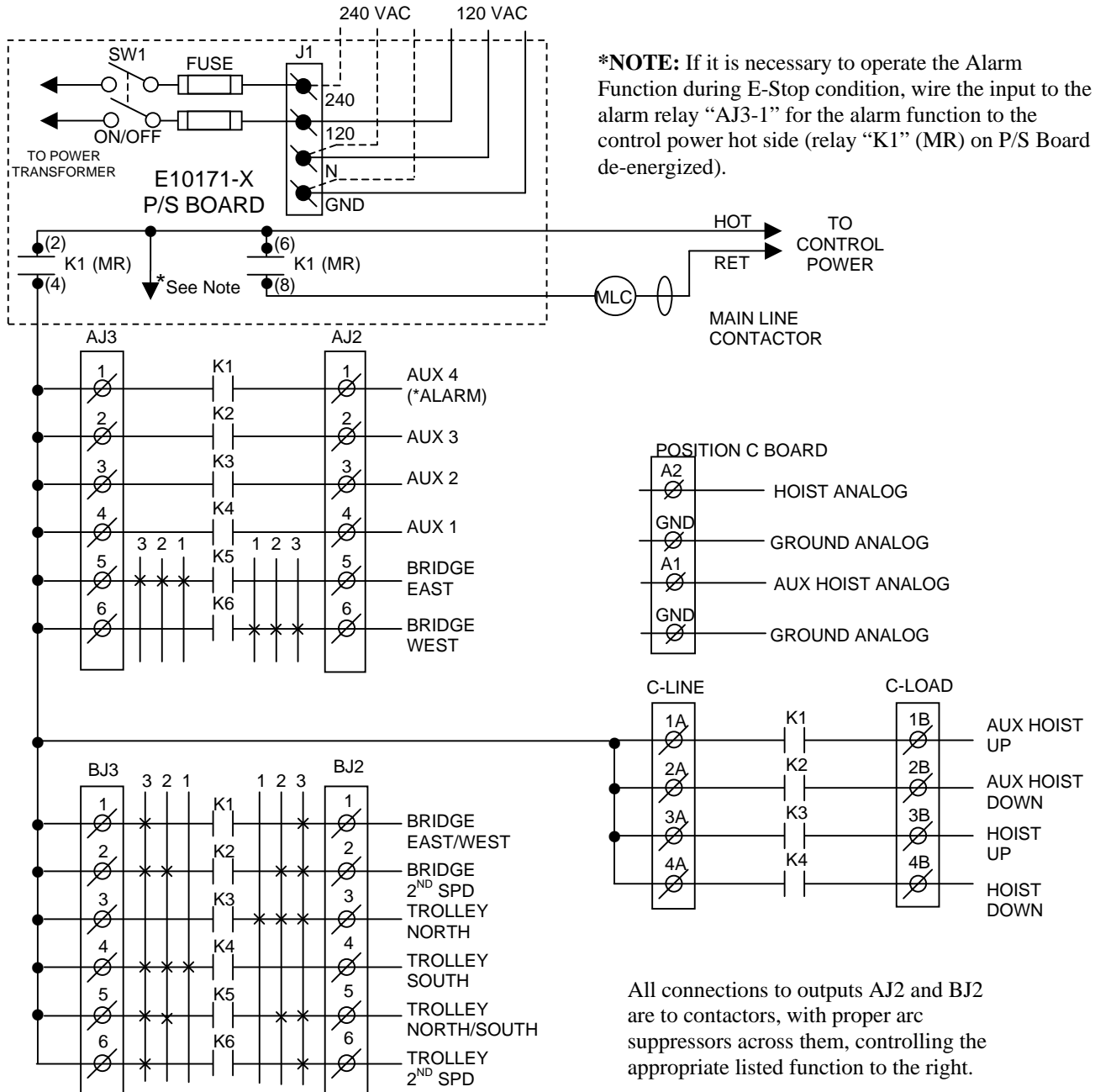

Section 4 – Optional Wiring Tables (Continued)

TABLE 4(b)

Crane Control Type Selection:

10KS1603P5, 10K Stepless Hoist, 2-Speed Trolley and Bridge

TYPE 1 PROGRAMMING

2-SPEED with DIRECTIONAL CONTROL: TROLLEY and BRIDGE

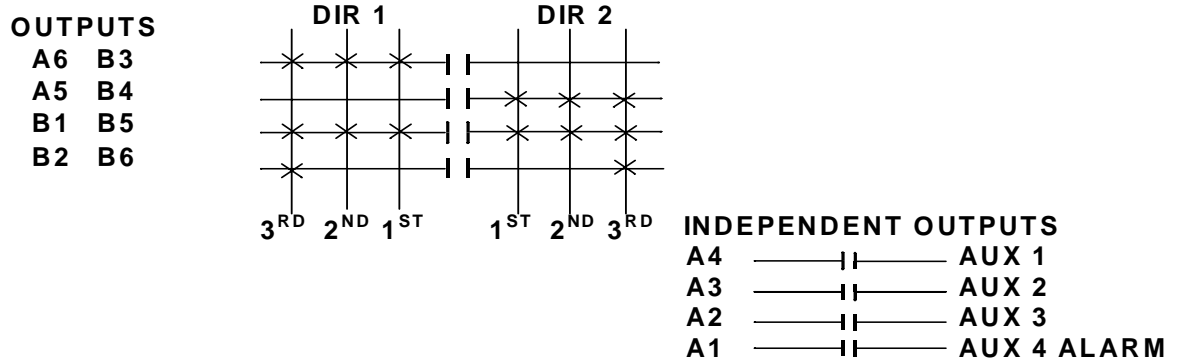

OUTPUT DEFINITIONS

BRIDGE

- A5 EAST
- A6 WEST
- B1 EAST/WEST
- B2 2ND SPEED

TROLLEY

- B3 NORTH
- B4 SOUTH
- B5 NORTH/SOUTH
- B6 2ND SPEED

INDEPENDENT OUTPUTS

- A1 AUX 4 (ALARM)
- A2 AUX 3 (LATCHABLE S2-6)
- A3 AUX 2 (LATCHABLE S2-7)
- A4 AUX 1 (LATCHABLE S2-8)

Transmitter Switch Select: "D" Switch settings Sw4-5 to Sw4-7 are defined as follows:

TRANSMITTER SWITCH SETTINGS: TYPE	<i>Sw4-7</i>	<i>Sw4-6</i>	<i>Sw4-5</i>
1	OFF	OFF	ON

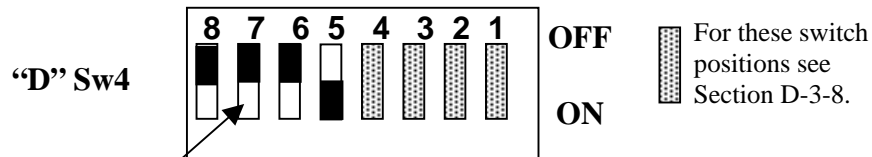

Indicates Switch in OFF Position.

Section 4 – Optional Wiring Tables (Continued)

TABLE 4(c)

**Crane Control Type Selection:
10KS1603P5, 10K Stepless Hoist, 3-Speed Trolley and Bridge
TYPE 2 WIRING DIAGRAM
2-SPEED, 2-WINDINGS: TROLLEY and BRIDGE**

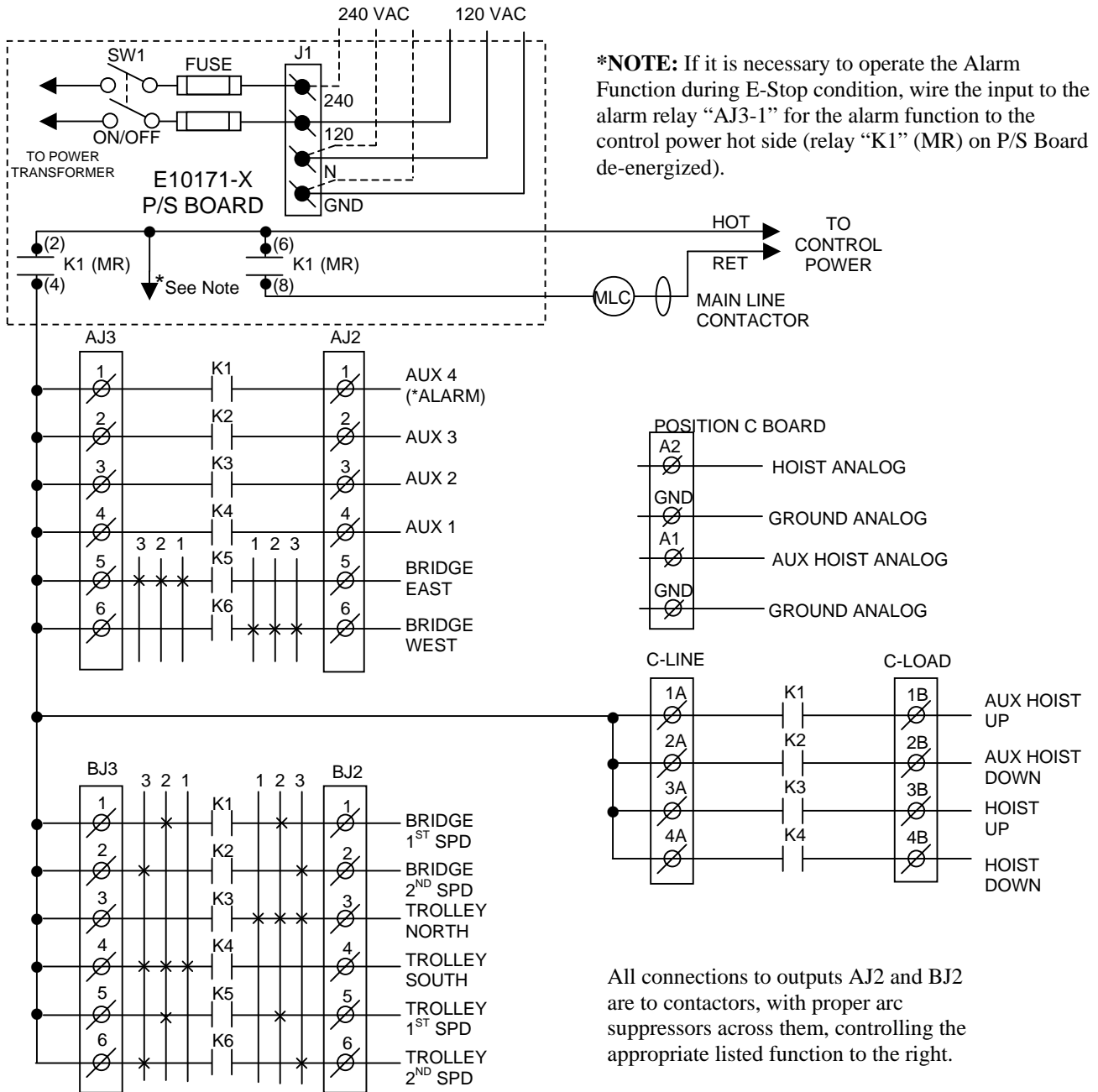

Section 4 – Optional Wiring Tables (Continued)

TABLE 4(c)

Crane Control Type Selection:

10KS1603P5, 10K Stepless Hoist, 3-Speed Trolley and Bridge

TYPE 2 PROGRAMMING

2-SPEED, 2-WINDINGS: TROLLEY and BRIDGE

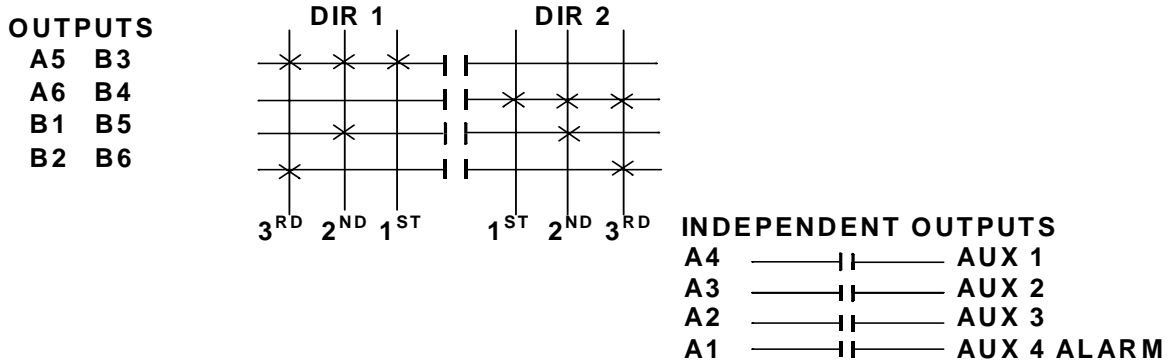

OUTPUT DEFINITIONS

BRIDGE

- A5 EAST
- A6 WEST
- B1 1ST SPEED
- B2 2ND SPEED

TROLLEY

- B3 NORTH
- B4 SOUTH
- B5 1ST SPEED
- B6 2ND SPEED

INDEPENDENT OUTPUTS

- A1 AUX 4 (ALARM)
- A2 AUX 3 (LATCHABLE S2-6)
- A3 AUX 2 (LATCHABLE S2-7)
- A4 AUX 1 (LATCHABLE S2-8)

Transmitter Switch Select: "D" Switch settings Sw4-5 to Sw4-7 are defined as follows:

TRANSMITTER SWITCH SETTINGS: TYPE	<i>Sw4-7</i>	<i>Sw4-6</i>	<i>Sw4-5</i>
2	OFF	ON	OFF

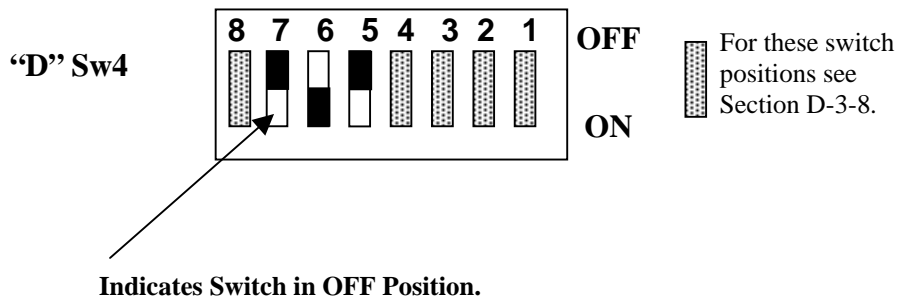

Section 4 – Optional Wiring Tables (Continued)

TABLE 4(d)

**Crane Control Type Selection:
10KS1603P5, 10K Stepless Hoist, 2-Speed Trolley and Bridge**

TYPE 3 WIRING DIAGRAM

ACCO CONTROLS: TROLLEY and BRIDGE

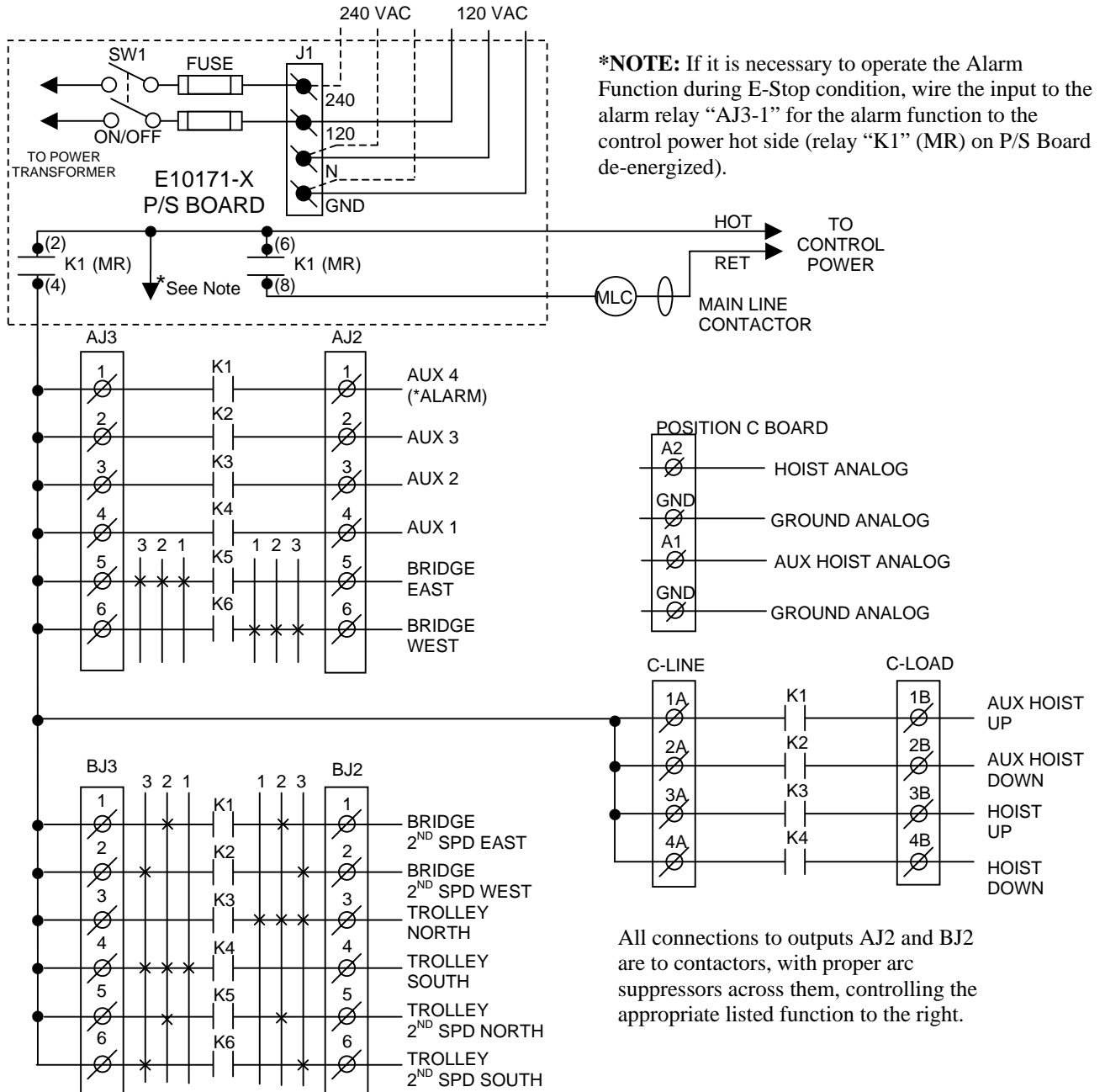

Section 4 – Optional Wiring Tables (Continued)

TABLE 4(e)

**Crane Control Type Selection:
10KS1603P5, 10K Stepless Hoist, 2-Speed Trolley and 3-Speed Bridge**

TYPE 6 WIRING DIAGRAM

P&H: TROLLEY and STANDARD BRIDGE

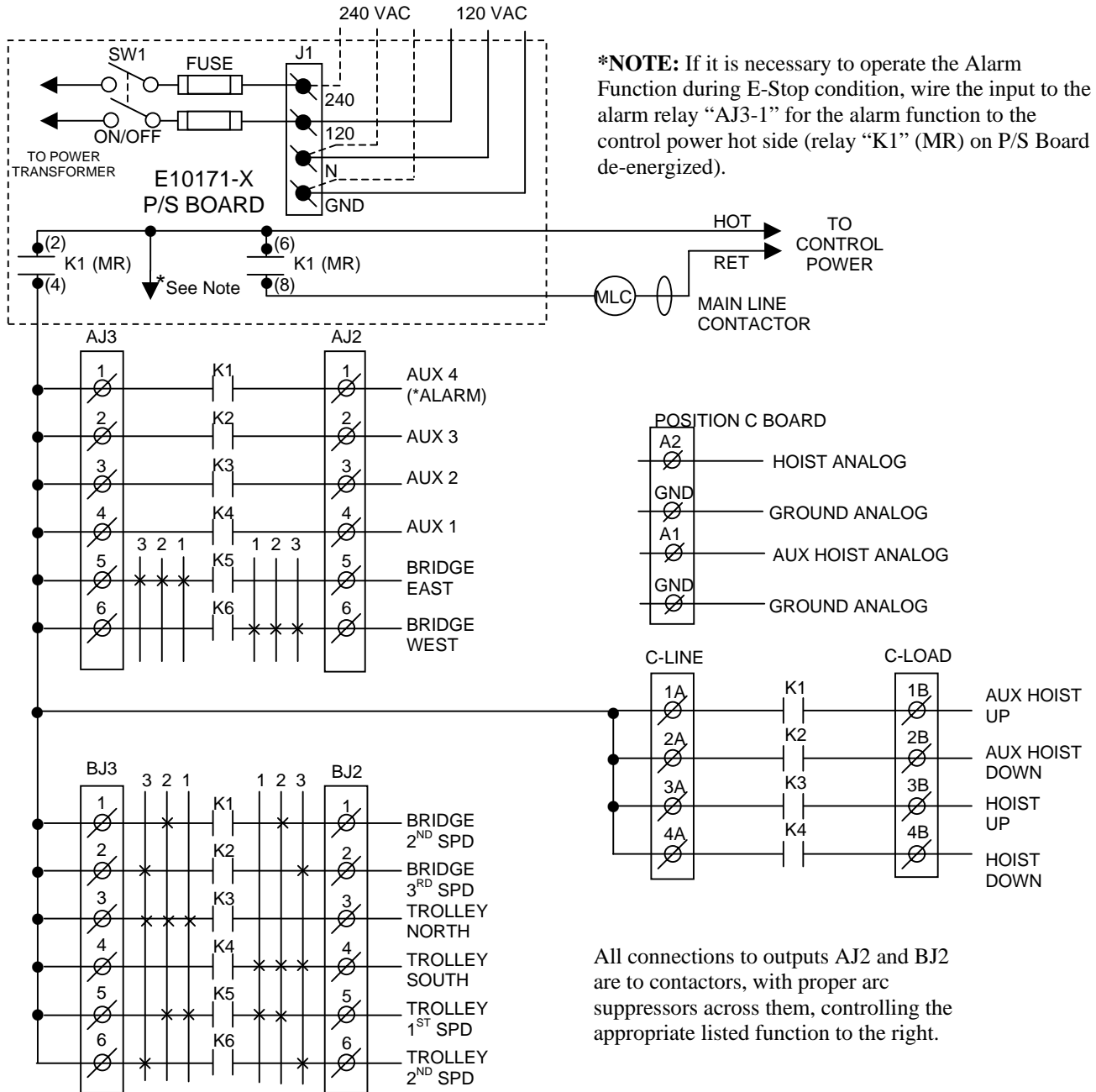

Section 4 – Optional Wiring Tables (Continued)

TABLE 4(e)

**Crane Control Type Selection:
10KS1603P5, 10K Stepless Hoist, 2-Speed Trolley and 3-Speed Bridge**

TYPE 6 PROGRAMMING

P&H: TROLLEY and STANDARD BRIDGE

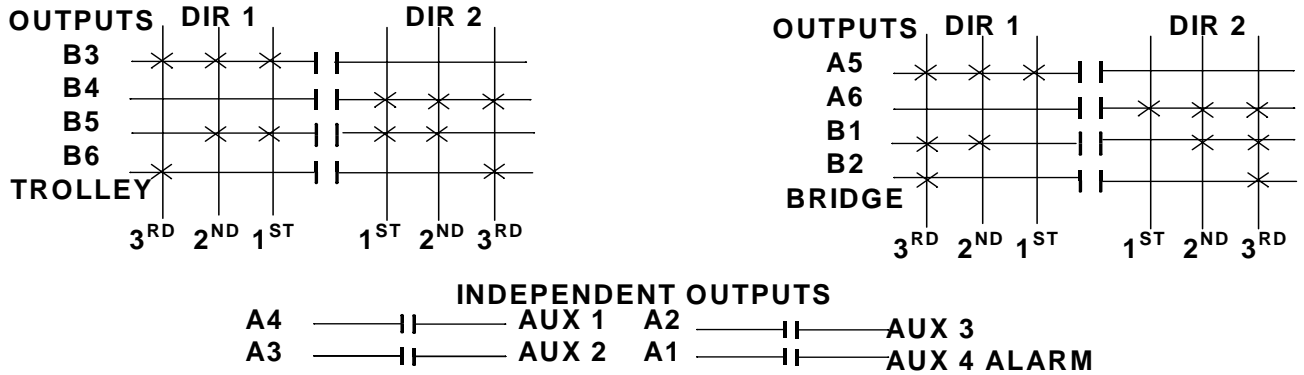

OUTPUT DEFINITIONS

BRIDGE

- A5 EAST
- A6 WEST
- B1 2ND SPEED
- B2 3RD SPEED

TROLLEY

- B3 NORTH
- B4 SOUTH
- B5 1ST SPEED
- B6 2ND SPEED

INDEPENDENT OUTPUTS

- A1 AUX 4 (ALARM)
- A2 AUX 3 (LATCHABLE S2-6)
- A3 AUX 2 (LATCHABLE S2-7)
- A4 AUX 1 (LATCHABLE S2-8)

Transmitter Switch Select: "D" Switch settings Sw4-5 to Sw4-7 are defined as follows:

TRANSMITTER SWITCH SETTINGS: TYPE	Sw4-7	Sw4-6	Sw4-5
	4	ON	OFF OFF

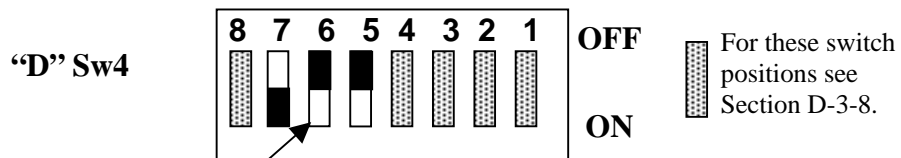

Indicates Switch in OFF Position.

Section 5 - Firmware

10K Stepless Systems Firmware Chart

5 Motor All Stepless With 2 Aux

Transmitters Units *With Flash Memory*

Pendent 4/5 Motor Stepless Hoist, Bridge & Trolley

(10KS2407P5) ----- replaces (FW2843)

FW3010-0

JLTX 4/5 Motor Stepless Hoist, Bridge & Trolley

(10KS2407J1) ----- replaces (FW2884)

FW3023-0

Receiver Units

10KS Stepless Single Box Systems

Master CPU/ Output Module *Single Box Version*

FW2842-0

10KS Stepless Multibox Systems

Master CPU/ Output Module *Multibox Version*

FW2858-0

4 Motor All Stepless With 4 Aux

Transmitters Units *With Flash Memory*

Pendent 4 Motor Stepless Hoist, Bridge & Trolley

(10KS1607P5) ----- replaces (FW2861)

FW3013-0

JLTX 4 Motor Stepless Hoist, Bridge & Trolley

(10KS1607J1) ----- replaces (FW2885)

FW3024-0

Receiver Units

10KS Stepless Single Box Systems

Master CPU/ Output Module *Single Box Version*

FW2859-0

10KS Stepless Multibox Systems

Master CPU/ Output Module *Multibox Version*

FW2860-0

3 Motor All Stepless With 6 Aux

Transmitters Units *With Flash Memory*

Pendent 3 Motor Stepless Hoist, Bridge & Trolley

(10KS1207P7) ----- replaces (FW2864)

FW3007-0

JLTX 3 Motor Stepless Hoist, Bridge & Trolley

(10KS1207J2) ----- replaces (FW2883)

FW3022-0

Receiver Units

10KS Stepless Single Box Systems

Master CPU/ Output Module *Single Box Version*

FW2862-0

10KS Stepless Multibox Systems

Master CPU/ Output Module *Multibox Version*

FW2863-0

4 Motor Stepless Hoist, 3 Speed Bridge and Trolley With 4 Aux

Transmitters Units *With Flash Memory*

Pendant 4 Motor Stepless Hoist, 3 Speed Bridge & Trolley

(10KS1603P5) ----- replaces (FW 2865)

FW3011-0

JLTX 4 Motor Stepless Hoist, 3 Speed Bridge & Trolley

(10K16S03J1) ----- replaces (FW2889)

FW3028-0

Receiver units

10KS Stepless Single Box Systems

Master CPU/ Output Module *Single Box Version*

FW2839-0

10KS Stepless Multibox Systems

Master CPU/ Output Module *Multibox Version*

FW2840-0

Section 5 – Firmware (Continued)

3 Motor Stepless Hoist, 2 Speed Bridge and Trolley With 4 Aux		
Transmitters Units With Flash Memory		
<u>Pendent 3 Motor Stepless Hoist, 2 Speed Bridge & Trolley</u> (10KS1202P7) ----- replaces (FW 2868)		FW3008-0
<u>JLTX 3 Motor Stepless Hoist, 2 Speed Bridge and Trolley</u> (10KS1202J2) ----- replaces (FW 2886)		FW3025-0
Receiver units		
<u>10KS Stepless Single Box Systems</u>		
Master CPU/ Output Module <i>Single Box Version</i>		FW2866-0
<u>10KS Stepless Multibox Systems</u>		
Master CPU/ Output Module <i>Multibox Version</i>		FW2867-0
3 Motor 2 Speed Hoist, Stepless Trolley and Bridge With 6 Aux		
Transmitters Units With Flash Memory		
<u>Pendent 3 Motor 2 Speed Hoist, Stepless Trolley & Bridge</u> (10KS1220P7) ----- replaces (FW 2869)		FW3009-0
<u>JLTX 3 Motor 2 Speed Hoist, Stepless Trolley & Bridge</u> (10KS1220J2) ----- replaces (FW 2887)		FW3026-0
Receiver units		
<u>10KS Stepless Single Box Systems</u>		
Master CPU/ Output Module <i>Single Box Version</i>		FW2859-0
<u>10KS Stepless Multibox Systems</u>		
Master CPU/ Output Module <i>Multibox Version</i>		FW2860-0
3 Motor 2 Speed Hoist and Trolley, Stepless Bridge With 4 Aux		
Transmitters Units With Flash Memory		
<u>Pendent 3 Motor 2 Speed Hoist & Trolley, Stepless Bridge</u> (10KS1221P7) ----- replaces (FW 2897)		FW3012-0
<u>JLTX 3 Motor 2 Speed Hoist & Trolley, Stepless Bridge</u> (10KS1221J2)		FW3039-0
Receiver units		
<u>10KS Stepless Single Box Systems</u>		
Master CPU/ Output Module <i>Single Box Version</i>		FW2866-0
<u>10KS Stepless Multibox Systems</u>		
Master CPU/ Output Module <i>Multibox Version</i>		FW2867-0