

## ***Electric Shoe Brakes Wheel Sizes 15" and 16"***

---

Mondel Electric Shoe Brakes - Wheel Sizes 15" and 16" Instruction Manual



**MAGNETEK**  
MATERIAL HANDLING

---

**Mondel**

Part Number: 560039-R1

January 2006

© Copyright 2006 Magnetek Material Handling



**MAGNETEK**  
MATERIAL HANDLING

---

**Mondel**

## **Installation and Maintenance Instructions**

### **Type SA1 Electric Shoe Brakes Wheel Sizes 15 and 16 Inches Diameter**

#### **SUPPLEMENTS FORMING PART OF THIS MANUAL:**

LOW TORQUE SPRINGS  
NON-LATCHING HAND RELEASE  
FORCING RECTIFIER  
NON-FORCING RECTIFIER  
TERMINAL BOX RECTIFIER  
"MANUAL RELEASE ACTIVATED" LIMIT SWITCH

---

**BRAKE WEIGHT:**

---

**APPLICABLE DIMENSION PRINT:**

---

**EXPLODED VIEW:**

---

**PARTS LIST:**

**Table of Contents**

Chapter 1.0: SA1 Electric Shoe Brakes 15 and 16 Inches Warnings and Cautions..... 4  
Chapter 2.0: General Description..... 7  
Chapter 3.0: Application..... 9  
Chapter 4.0: Description of Operation..... 10  
Chapter 5.0: Installation ..... 12  
Chapter 6.0: Adjustment..... 15  
Chapter 7.0: Electrical Detail..... 18  
Chapter 8.0; Operational Test..... 21  
Chapter 9.0: Maintenance and Repair ..... 22  
Chapter 10.0: Replacement Parts..... 27  
Chapter 11.0: Long Term Storage..... 29

**Chapter 1.0: SA1 Electric Shoe Brakes 15 and 16 Inches Warnings and Cautions**

**Read and Understand All Warnings And Cautions Printed In This Manual Before Commencing Installation, Adjustment Or Repair**

**Chapter 5: Installation – Warnings and Cautions**

**Anyone involved in the installation or service of this brake must have:**

- Received specific training.
- Had experience on similar equipment.
- Knowledge of the equipment on which the brake is installed.
- The ability to understand the terminology.
- The ability to understand the diagrams.

**Do not proceed unless technically qualified for the work involved.**

**The integrity of the brake may be compromised or a replacement part may not fit if alterations are made to the brake to achieve required alignment.**

**If the alterations to the brake supporting structure are required, they must be done under the direction of a competent authority.**

**All electrical power to this equipment must be disconnected by competent personnel. Consult specific wiring diagrams to identify and isolate all live power inputs to the equipment.**

**Unexpected movement or hazardous voltage can cause injury or death. Disconnect, lock out, and tag out the power source that feeds this device to prevent power from being applied while inspection and repairs are being performed. Before beginning repairs, try the operational controls to verify that the intended power source is disconnected.**

**Protect against the possibility of movement due to the effects of gravity, wind or other source of energy, which has the potential to create a hazard when the brake is being worked on or is removed entirely.**

**On a hoist, chock the drum to prevent any rotation, due to the effect of gravity on the hook block etc.**

**On the travel motion subject to the effect of wind or camber gradient, apply the wind anchors or otherwise secure the equipment against inadvertent movement when the brake is being worked on or is removed entirely.**

**Never lift the brake assembly by the brake rod. The weight of the brake can irreversibly damage the rod leading to fracture and total loss of braking effect.**

**Failure to properly install the brake wheel may result in the brake wheel working its way off the motor shaft, resulting in total loss of braking. Do not operate this brake unless the brake wheel is correctly secured to the motor shaft.**

**The brake wheel installation must be complete and the brake wheel fully secured before attempting to finalize the brake installation.**

**Failure to properly center the brake and obtain uniform lining contact causes local heating and, ultimately, reduced torque leading to injury or death.**

**Connect power to the brake using flexible cable and sealing gland, or flexible sealed conduit. Prevent contaminant entry and allow for movement of the electro-magnet during brake operation.**

## **Chapter 6: Adjustment – Warnings and Cautions**

**Disconnect, lock out, and tag out the disconnect switch which feeds this equipment to prevent power from being applied while service is being performed.**

**Monitor the brake frequently, and do not allow the air gap to exceed the maximum value as shown on the adjacent setting plate.**

**Under no circumstances should the brake be allowed to function without torque spring pre-compression. Load control will be lost, possibly resulting in injury or death.**

**WARNING: Reducing the torque to the applied brake's lower limit may seriously affect the brake's drop-out time.**

**Caution: Braking torque is lost when torque spring pre-compression is reduced to zero.**

## **Chapter 7: Electrical Detail – Warnings and Cautions**

**A flexible cable and sealing gland, or flexible sealed conduit must be used to connect power to the electro-magnet. Prevent contaminant entry and allow a few degrees of movement for the actuator during brake operation.**

**Avoid contact with "live" terminals and prevent contaminant entry. Replace the terminal box cover as soon as connections are complete.**

## **Chapter 8: Operational Test – Warnings and Cautions**

**Always perform an operational test of the brake after any replacement, adjustment, or repair. Read and understand the intent of the warnings published in this document – if in doubt, ask.**

**In a hoist application, post observers to monitor the position of the hook if it travels out of sight of the operator.**

**Before conducting an operational test, remove all tools, chocks and other equipment, which may create a hazard when the machine is operated.**

**Following any repair or adjustment, and before conducting an operational test, verify that all brake adjustments are complete in accordance with Chapter 6.**

**Before attempting to operate any motion in any application, advise and account for the location and security of all personnel involved.**

## **Chapter 9: Maintenance and Repair – Warnings and Cautions**

**When replacing a brake wheel or associated drive line components on an existing installation, verify that the brake is centered with uniform lining contact as described under the topic “Brake Installation”. Incorrect repair or replacement can result in death or injury to personnel.**

**Improper brake operation and loss of load control due to incorrect brake adjustment can result in death or injury to personnel.**

## **Chapter 2.0: General Description**

- 2.1: The type SA1 spring applied brakes are intended for hoist or travel motion drives in light to medium duty industrial applications, at up to 120 operations per hour. They are available for brake wheels 4" to 16" diameter. SA1's are ideal in adjustable frequency motor control systems where deceleration energy is absorbed by the motor, and the brake essentially functions to hold the load; consequently, shoe wear is minimal.
- 2.2: This versatile spring applied, DC magnet released, short stroke, high-speed, low armature impact brake has dual internal torque springs adjustable down to 50% of maximum rated torque. Lower torque springs are available as factory installed options.
- 2.3: Type SA1 brakes comply with both CSA and UL standards.
- 2.4: Magnet coils, for shunt and series applications, are computer designed to NEMA standards and wound with class "H" wire providing for class "B" temperature rise over a 40°C (104°F) ambient. Shunt type coils are rated for continuous duty; coils for series use are rated 30 min. or 60 min. duty.
- 2.5: Type "M" (molded) or type "W" (woven) linings are available. Type "W" linings deliver 15% less torque than type "M" linings, but are generally easier to bed and are more tolerant of an existing grooved wheel.
- 2.6: The coil is encapsulated into the magnet frame using modified class "F" thermo-setting resin potting compound. This keeps out contamination and aids in the distribution of coil heat to the magnet casing.
- 2.7: Where AC is available, shunt type magnets can be used in conjunction with a variety of Mondel "forcing" and "non-forcing" rectifiers.
- 2.8: At full torque, maximum armature air gap and normal operating temperature SA1 shunt-connected brakes are designed to release at 80% of rated line voltage. Shunt type brakes are available for operation from 12Vdc to 550Vdc; 105Vdc is typical.
- 2.9: Where high speed performance is not essential, the Mondel type SA1 brakes can be supplied with an integral terminal box rectifier and wound for direct connection to an AC supply of up to 600 Vac.
- 2.10: Series connected brakes are designed to release at 40% full-load motor current and re-apply as the current decreases to 10%.
- 2.11: In addition to standard Mondel footprints and shaft heights, the type SA1 brakes can be supplied in AISE/NEMA footprints and shaft heights.
- 2.12: The Mondel type SA1 brakes can be supplied as "drop-ins" with footprint and shaft heights to replace a wide range of competitor's brakes, including some metric sizes.
- 2.13: For highly corrosive applications, special hardware, enclosures and surface treatments are available.

Figure 1

General Arrangement  
SA1 Electric Shoe Brake

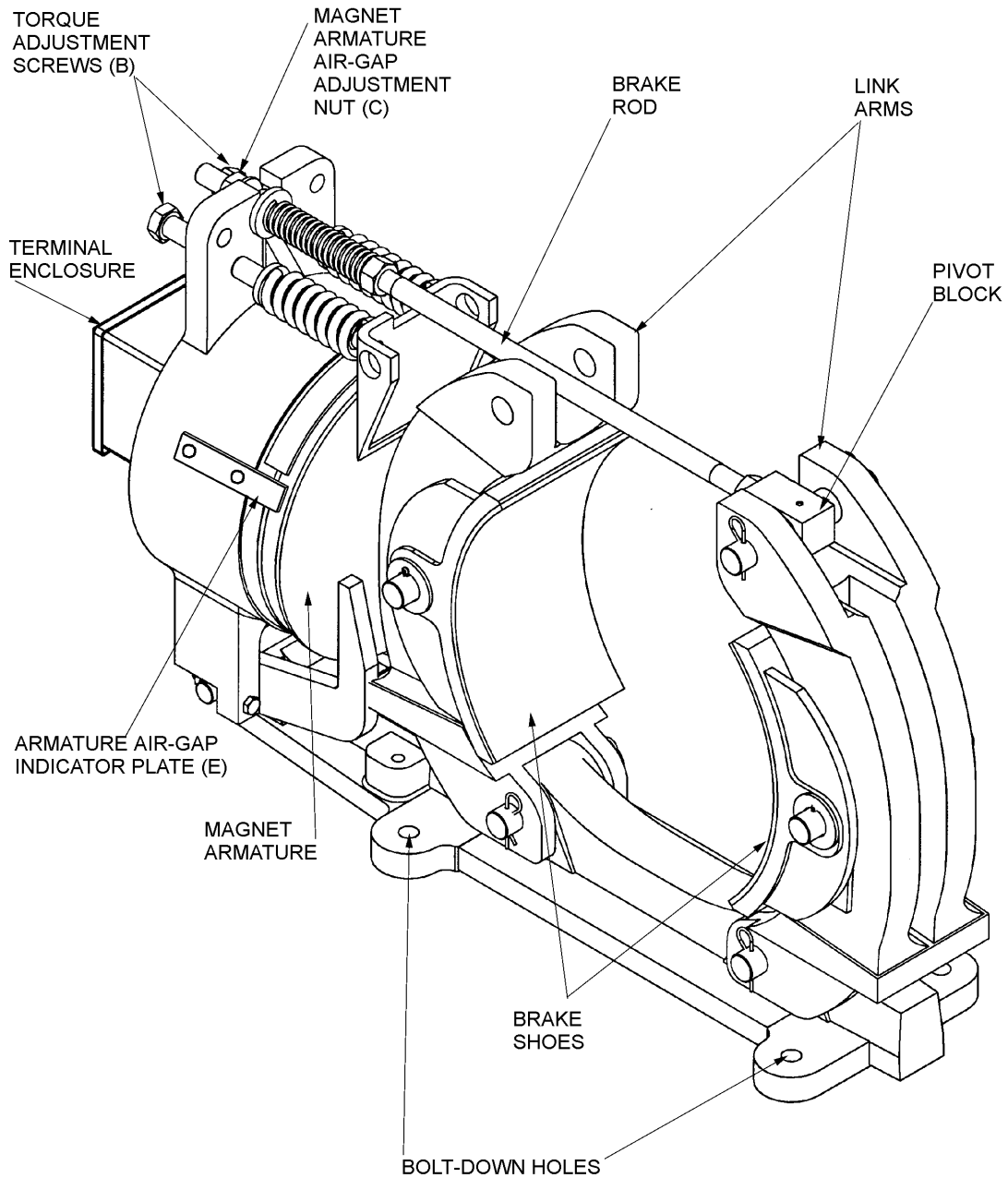

### **Chapter 3.0: Application**

3.1: Type SA1 brakes can be supplied in torque ratings to the following industry standards:

**3.1.(a):** For a given wheel diameter the Association Of Iron And Steel Engineers (AISE) and the National Electrical Manufacturers Association (NEMA) standards define the maximum torque required from 30 to 60 min. rated series type, and 60 min. and 8 hr. rated shunt type brakes in steel mill applications.

**3.1.(b):** The SA1 brake can also be provided with torque values greater than AISE/NEMA ratings, when wheel heating can be accurately predicted. Typical of such applications would be Variable Frequency or other four quadrant drives.

**3.1.(c):** The Mondel Type SA1 brake can also be provided with torque values lower than AISE/NEMA recommendations. These ratings would be suitable for applications where the load cycle requires a larger than normal wheel size, as is frequently the case on crane bridge drives.

**3.1.(d):** The wheel face width necessary for type SA1 brakes is greater than that for AISE brakes in standard sized "8" and "10". Type SA1 wider wheels or special narrow linings are necessary to correct this situation.

**IF YOU HAVE AN UNUSUAL APPLICATION, OR REQUIRE A RECOMMENDATION FOR A BRAKE SIZE AND TYPE, CONTACT MAGNETEK.**

#### **Chapter 4.0: Description of Operation**

- 4.1: Type SA1 brakes are spring applied and dc magnet releases. Heavy-duty compression springs provide the necessary force to apply the linings against the wheel. When power is applied, the armature of the electro-magnet closes and compresses the springs, while pulling the shoes away from the wheel to provide running clearance. See Fig. 2.
- 4.2: Notwithstanding brake geometry, braking torque depends upon three major factors:
- 4.2.(a):** The wheel diameter.
  - 4.2.(b):** The coefficient of friction of the lining material.
  - 4.2.(c):** The force with which the linings are applied to the wheel.
- 4.3: Electro-magnet operation cancels the brake's ability to apply torque.
- 4.4: As the applied shoe force is proportional to the compressed spring length, a slight decrease in brake torque occurs as the linings wear to the recommended adjustment point. Re-adjustment of the magnet air gap to its recommended value will both restore the required shoe clearance and the specified torque.

**NEMA states: "The torque ratings apply at a worn lining condition defined as the point where readjustment is required as recommended by the manufacturer."**

- 4.4.(a):** When the coil is energized and the armature attracted fully home, the spring is compressed while the shoes are retracted to provide running clearance from the wheel.
  - 4.4.(b):** Total running clearance provided by the magnet air gap is equalized by means of the effective shoe clearance equalization bolt. See Fig. 2.
- 4.5: SA1 brakes are equipped with self-aligning parallel clearance shoes designed to allow for greater tolerance of wheel run-out, etc.
- 4.6: Various optional features, including hand release mechanisms, limit switches, hydraulic and pneumatic overrides, etc. are described in separate manuals. If the brake covered by this manual has any of the optional features, they will be listed on the front page of this manual.

Figure 2

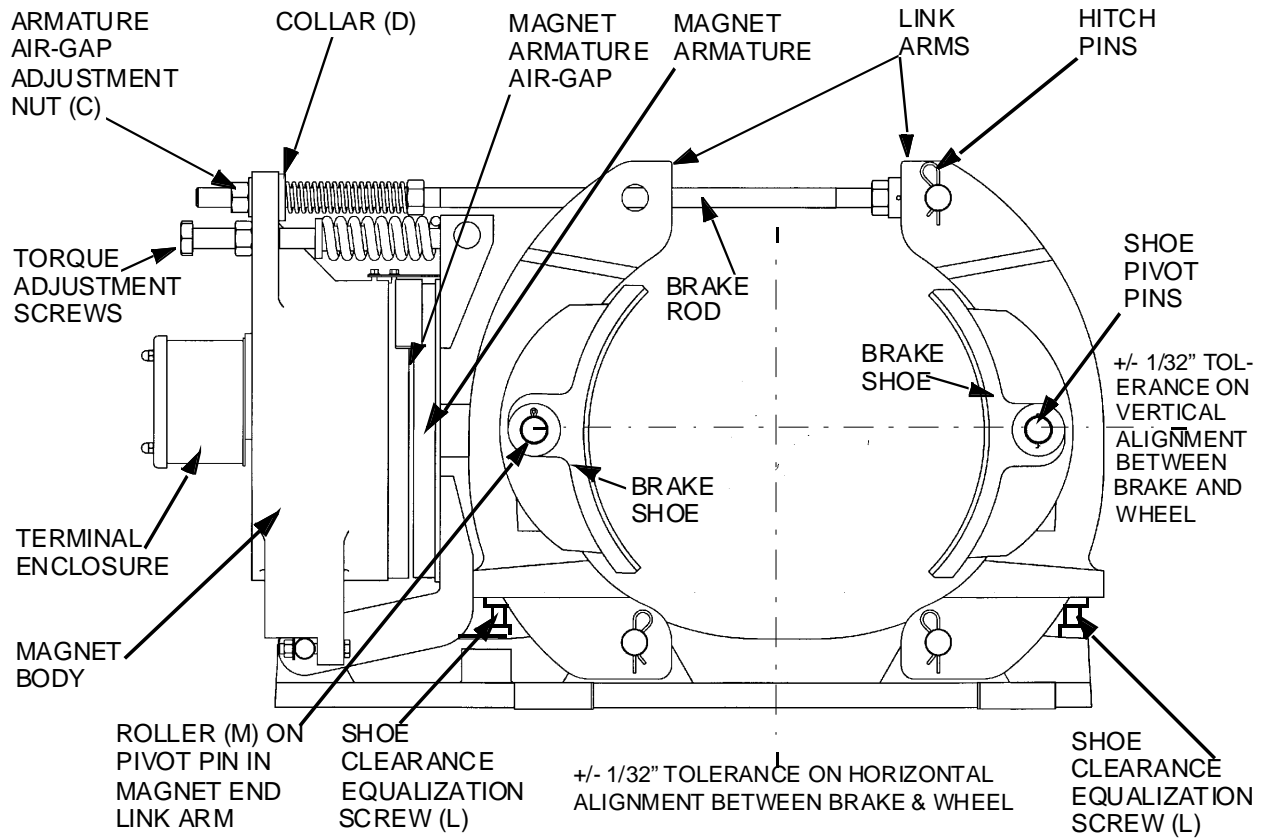

## **Chapter 5.0: Installation**

- 5.1: After unpacking, visually inspect the brake assembly to ensure that damage has not occurred during shipment and that there are no loose or missing parts. Verify that the intended power source is correct for the application.
- 5.2: Generally, the wheel is installed before the brake assembly, although site conditions and handling facilities may determine otherwise.

**Due to the variety of designs, brake wheel installation details are not covered in this manual. Consult the bulletin on the specific wheel employed for assembly methods, fits and tolerances.**

- 5.3: Install the wheel as detailed elsewhere.
- 5.4: Prepare the brake support structure and install the brake assembly subject to the following:
- 5.4.(a):** Leave enough clearance, at each end of the brake assembly, for the link arms to be swung away from the wheel to permit brake shoe service, etc.
- 5.4.(b):** Whether mounting a brake in a new or existing installation, the mounting bolts need a reasonable clearance in the base mounting holes. There must be enough tolerance to allow the brake to be mounted and aligned for full contact between the brake lining and the wheel once bedding is completed.
- 5.4.(c):** Center the brake shoes across the width of the brake wheel. This avoids ridge formation and the possible creation of a dangerous situation as the linings wear.
- 5.5: In most applications the brake assembly is installed over the brake wheel, by introducing the brake axially to the wheel from the wheel's open side face. Follow procedures under the topic "Releasing the Brake" in Chapter 6.
- 5.5.(a):** Alternatively, it may be necessary to move the brake assembly laterally into position around the wheel, i.e. towards the braking surface of the wheel. This requires partial disassembly of the brake. Disconnect the brake rod so that it swings clear of the link arm assemblies. See Fig. 5 and Chapter 9 topic: "Replacing the Brake Shoes". Then, remove the shoe and link arm assembly at the end opposite the electro-magnet.
- 5.6: Whichever method is used, leave uniform clearance, between brake shoes and wheel, for correct alignment when adjustments are made.
- 5.7: Position the brake assembly over the brake wheel, re-assembling as needed, and apply shoe pressure. See Chapter 6, "Setting The Brake".
- 5.7.(a):** This action will apply the brake at approximately rated torque, cause the brake to square itself to the wheel, and maximize the shoe contact area prior to bedding.
- 5.8: Usually, brakes are mounted with their base horizontal, below a horizontally orientated motor and brake wheel assembly. Design flexibility allows the SA1 to operate in any position suited to the application.
- 5.9: Adjust the brake support bracket to achieve the specified horizontal and longitudinal alignment. Shim under the brake base for the vertical alignment. For best performance, the base of the brake should be flat and parallel to the wheel rim, or motor shaft. It may be necessary to release and re-apply the brake pressure several times to achieve optimum alignment.

**5.9.(a):** The brake assembly must be square to the wheel and aligned with the brake wheel within  $\pm 1/32$  inch, in three axes (horizontal, vertical, and longitudinal), (Fig. 2). bolt-down hole clearance provides minor adjustment.

**5.9.(b):** When the brake assembly is correctly aligned and clamped to the wheel, try each of the securing bolts in the brake base mounting holes. Check that brake shoes remain parallel to the face of the brake and that each brake shoe is fully secured to its link arm.

**5.9.(c):** Verify that brake shoe side clearance does not allow either shoe to ride over the edge of the wheel. Brake linings must never overhang the wheel face. With the shoes clamped to the brake wheel, re-check that the shoe braking surfaces remain parallel to the braking surface of the wheel, and that the center lines of the wheel and brake shoes are within  $\pm 1/32$  inch of each other. Re-locate the brake assembly if necessary to obtain uniform contact.

**5.9.(d):** Fully apply the brake and check that the lining area, in contact with the wheel, meets the initial minimum 60%. Emery paper will remove high spots and increase initial bedding area.

**5.9.(e):** Modern linings, although hard wearing, are difficult to “bed” when the area in contact with the wheel cannot support the heat energy transferred to the brake. As a result the linings will become “glazed” where in contact with the wheel. “Glazing” is the name given to a condition whereby the lining has been heated beyond its working temperature range and no longer delivers its designed coefficient of friction. “Glazing” is seldom removed by further braking operations as any increase of lining contact area will immediately be glazed.

**5.9.(f):** Prevent “Glazing” by obtaining at least 60% lining to wheel contact area before load is applied to the brake.

**5.9.(g):** The required lining contact is seldom achieved without “bedding”, but time spent to achieve satisfactory bedding will be rewarded with a considerably longer life for the lining.

**5.9.(h):** Once 60%, or greater, lining contact is obtained, well spaced, short bursts of energy, such as an E.Stop at high speed with no load, are best to complete “bedding”. This procedure will limit the energy input to the wheel and allow control of temperature rise.

5.10: When the brake is correctly aligned in all three axes, tighten the brake mounting bolts and re-check the alignment.

5.11: Flexible sealed conductors, suitable for the rated temperature, must be used to connect the brake release magnet to its power supply terminals. Use type “S0” or higher temperature cable. The magnet assembly must be allowed a few degrees of movement without the risk of dirt or moisture entering the terminal box.

**Table 2**

BRAKE WHEEL SIZES (Inches)	TYPICAL RUNNING CLEARANCE BETWEEN LINING AND BRAKE WHEEL (Inches)	MAXIMUM FULL SPEED BRAKE WHEEL run-out (Inches)
4	0.014	0.004
6	0.014	0.006
8	0.016	0.008
10	0.020	0.010
13	0.026	0.013
16	0.032	0.016

Notes:

1. Refer to "Brake Installation" and "Replacing the Brake Shoes" for adjustment instructions.
2. Evaluate brake wheel run-out at full speed. It must not exceed value shown in this table.

## **Chapter 6.0: Adjustment**

6.1: Following any adjustment or repair of the brake, test operation of the brake as described under "Operational Test", Chapter 8.

6.2: See Chapter 9 for recommendations on periodic adjustments. Complete adjustment is normally required only following rework during which most settings were disturbed.

6.3: Setting and Releasing the Brake

Note: Brake installation, shoe replacement and coil replacement, described elsewhere, require the brake to be released and set without energizing the magnet.

### **6.3.(a): Releasing The Brake**

**6.3.(b):** Slacken off nut (C), see Fig. 2, increase the brake rod length, until the shoes are not forced against the wheel. At this point it should be possible to dis-engage the spring loaded collar and swing the tie rod over to fully access the brake for shoe replacement, and most other servicing, including vertically lifting the drive motor and brake wheel assembly out of the brake. Note that shoe removal requires brake rod disconnection; see Chapter 9, Maintenance and Repair.

6.4: Setting The Brake

**6.4.(a):** Tighten nut (C), see Fig. 2, and decrease the brake rod length, until the linings contact the wheel and the electro-magnet armature is set to the specified air gap.

6.5: Brake Adjustments

**6.5.(a):** The brake torque and magnet armature air gap are factory set prior to shipment. If these settings are disturbed, for any reason, they can be reset as follows:

**6.5.(a).(i):** Adjust nut (C) to close the shoes on the wheel, while reducing the magnet armature air gap to the required value. The actual air gap is not visible, but an indicator plate (E), attached to the magnet housing, indicates the required gap. See Fig. 2.

**6.5.(a).(ii):** The two torque springs are not visible from outside the magnet housing. Changes to the torque setting can be made by adjusting the hex-headed cap screws (B), in or out, until the distance from the magnet housing, to the underside of each screw head, equals the dimension given on the adjacent setting plate. Re-tighten the lock-nuts. See Fig. 2.

**6.5.(a).(iii):** Finally, adjust the active hex cap screws (L) to equalize the clearance between each shoe and the wheel. Re-tighten lock-nuts.

**6.5.(a).(iv):** The brake is now correctly set to deliver rated torque output.

6.6: Torque Adjustment

**6.6.(a):** Notwithstanding brake geometry, the rated torque, as shown on the nameplate, is developed when the following conditions are met:

**6.6.(a).(i):** The brake is applied.

**6.6.(a).(ii):** The torque spring pre-compression is correctly set.

**6.6.(a).(iii):** The magnet armature air gap is set to the value specified on the instruction plate.

**6.6.(a).(iv):** The correct linings, in good condition, are fitted and bedding is completed.

**6.6.(b):** If less than the original specified torque is required at some time, the torque can be reduced to approximately 40% of maximum torque based on the applied springs. Reduce braking torque, to suit site conditions, as follows:

**6.6.(b).(i):** Carefully back off the adjustment screws (B) to decrease the torque spring compression.

**6.6.(c):** Braking torque may not be increased beyond the designated rating. Do not tighten adjustment screws (B) past their indicated setting; this will overload the magnet and could prevent correct release of the brake shoes.

**6.6.(d):** Brake “drop-out” response, when power is removed from the coil is affected by the thickness of a non-magnetic shim in the magnet air gap.

**6.6.(e):** The thickness of this shim is determined during factory testing to ensure that the maximum torque spring force will not cause the magnet to “let go” under the worst conditions of voltage, coil temperature or other NEMA requirements.

**6.6.(f):** When a brake is required for less than maximum rated torque, additional shimming may be required to ensure adequate “drop-out” response. Consult factory if a lower torque range than original is contemplated.

6.7: Shoe Clearance Adjustment

**6.7.(a):** The total available shoe clearance is determined by the magnet armature air gap. Distribution of the resulting clearance is determined by the position of shoe clearance equalizing bolts (L). See Fig. 2.

**6.7.(b):** To adjust the brake shoe running clearance:

**6.7.(b).(i):** Release the brake by energizing the magnet.

**6.7.(b).(ii):** Adjust screws (L), by turning them in or out, until the required clearance is achieved on each brake shoe. Tighten the lock nuts to lock the adjusting screws in place.

6.8: Shoe alignment adjustment

**6.8.(a):** For optimum lining wear distribution, brake shoes have controlled freedom to rotate under their own weight. As the linings wear, near parallel shoe clearance is assured by a pivot tension mechanism, which controls the brake shoe rotation as follows:

**6.8.(a).(i):** A spring loaded device located on the brake arm, see Fig 3, provides tension to control shoe rotation when the brake releases. The device is not adjustable. When replacing shoes make sure that the tension device is present.

**6.8.(b):** After the correct shoe clearance is set, align the shoes and wheel as follows:

**6.8.(b).(i):** Energize the electro-magnet to release the brake. Then use a soft-faced mallet to tap the upper edge of each brake shoe inwards towards the wheel. The arc through which each shoe pivots will be limited by its tension mechanism. This sets the brake shoes to their correct starting position, and ensures that the brake linings assume their designed alignment, with respect to the wheel, the next time the brake is applied.

**6.8.(b).(ii):** Re-apply the brake and the shoe linings, will accurately align with the wheel.

Figure 3

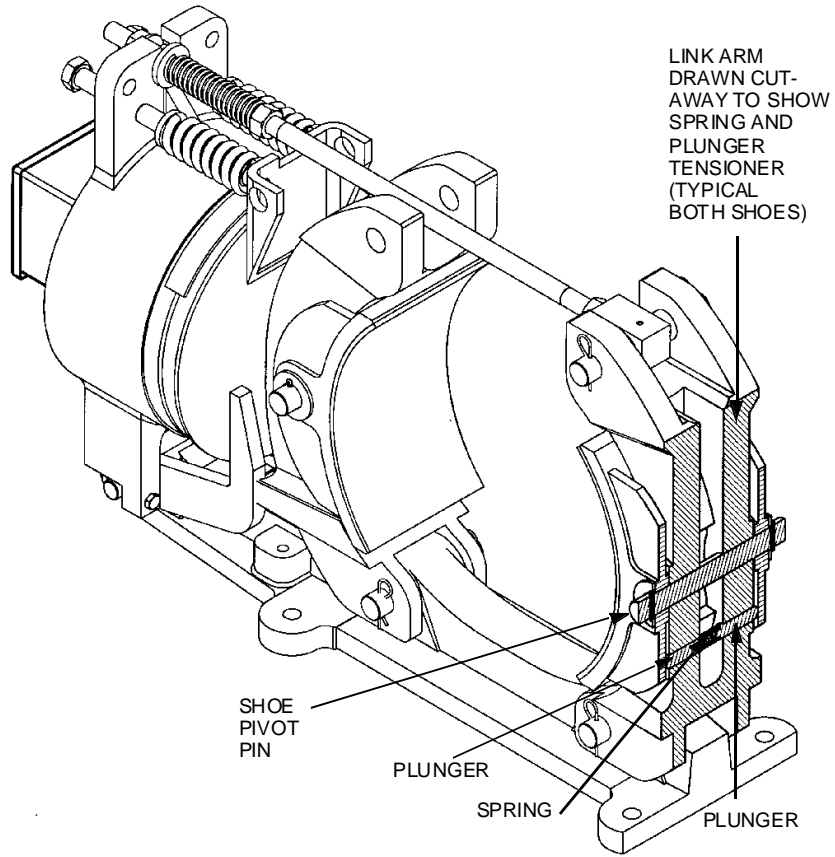

**Chapter 7.0: Electrical Detail**

- 7.1: The brake release magnet is independent of polarity, but the conventional connection for DC supply lines is positive line (+) to the RED wired terminal, and negative line (-) to the BLACK wired terminal.

**Figure 4B**

**Electrical Detail, Without Integral Rectifier**

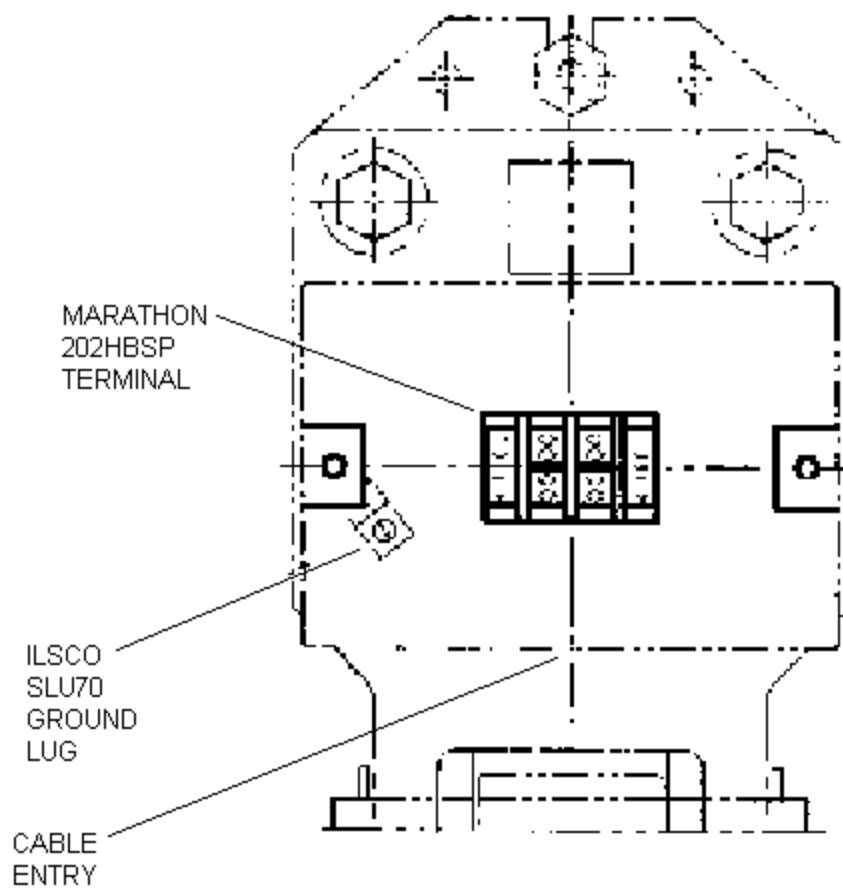
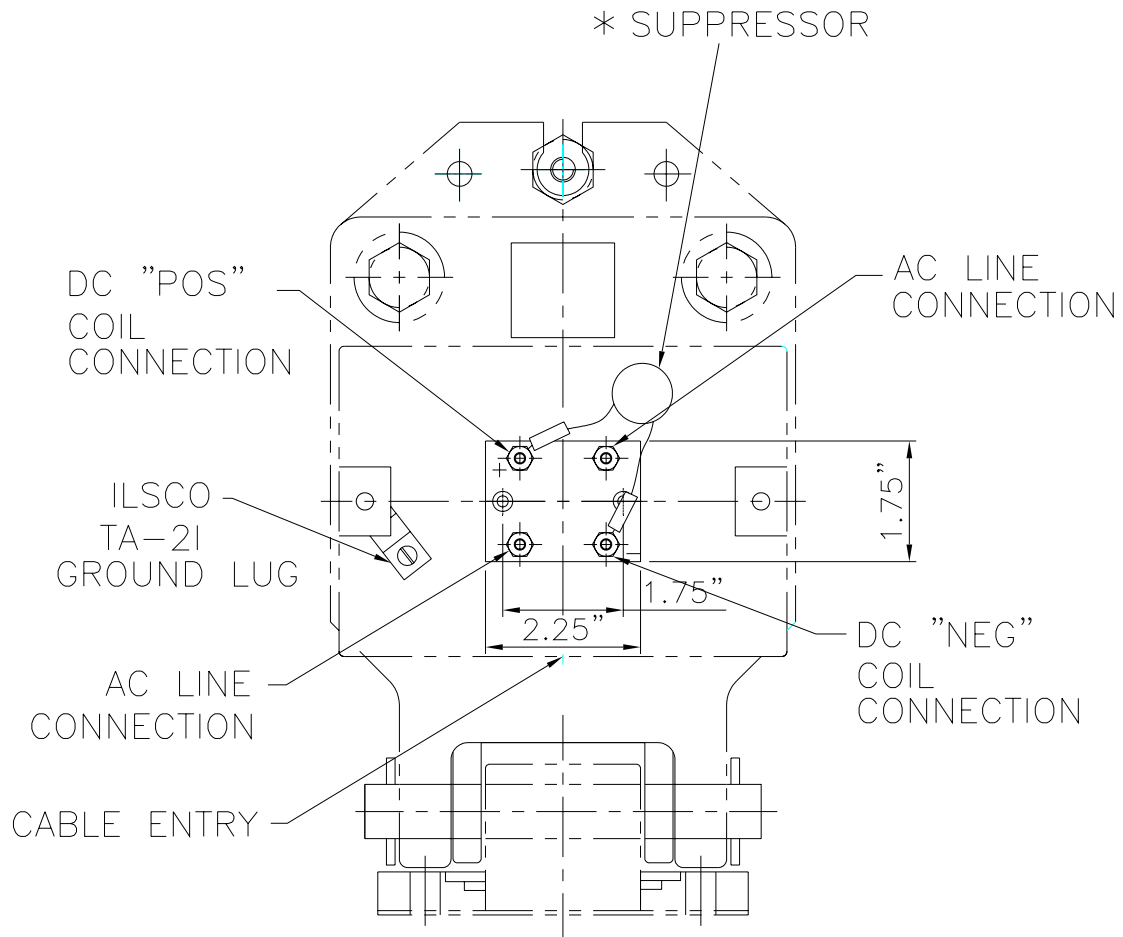

Figure 4

Electrical Detail, With Rectifier Located in Brake Terminal Box



RECTIFIER LOCATED  
IN BRAKE TERMINAL BOX

\* ONLY ON 460 & 575VAC UNITS

Figure 4A

Electrical Detail, With Rectifier Located in Brake Terminal Box

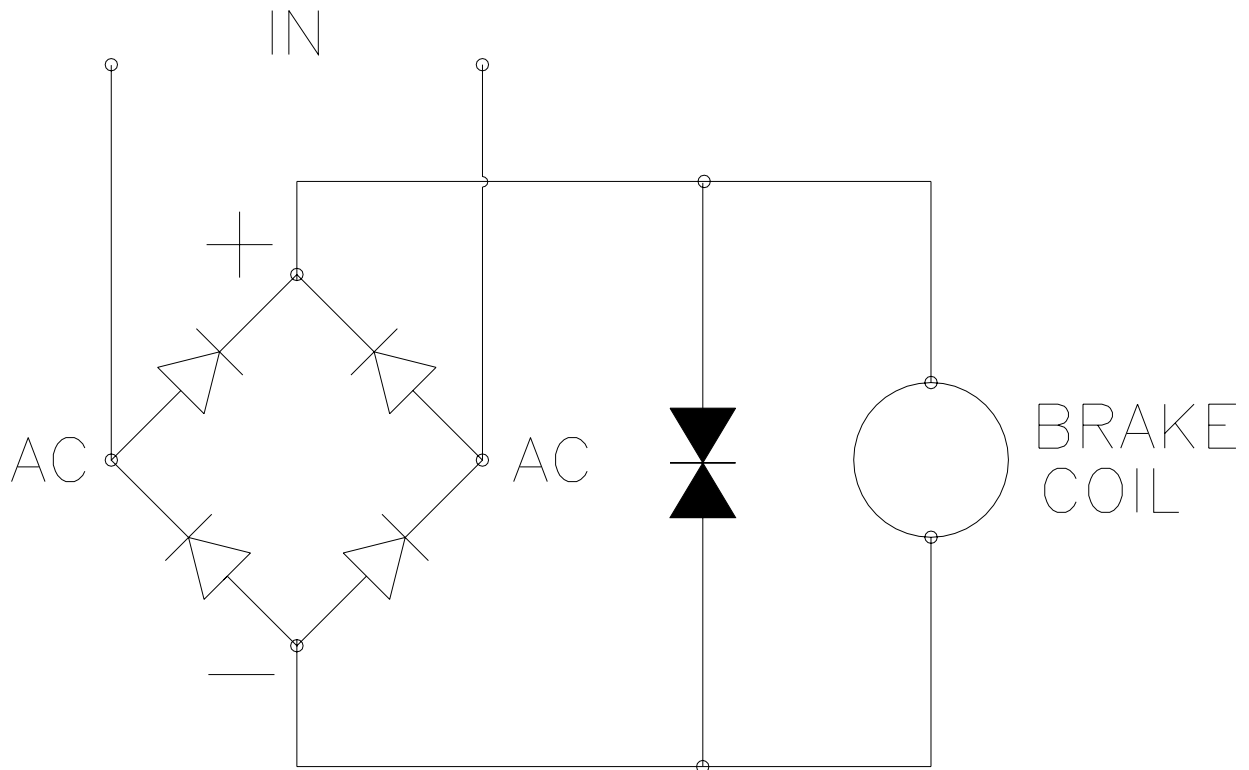

TYPICAL SCHEMATIC  
120-575VAC INPUT

## **Chapter 8.0; Operational Test**

- 8.1: Heed all warnings and cautions in addition to the owners' safety procedures.
- 8.2: Follow all standards and local statutes.
- 8.3: On new installations, confirm that each shoe has a minimum of 60% contact area between lining and wheel before subjecting the brake to its rated capacity. Refer to Chapter 5, Installation Instructions, for directions.
- 8.4: If re-lined shoes have been fitted, or the brake was altered in any way, make sure that the brake is subsequently re-aligned. This will minimize the bedding needed to obtain 60% of brake lining to wheel contact. Refer to Chapter 5, Installation Instructions, for directions.
- 8.4.(a):** Verify that only genuine Mondel lined brake shoes are used to maintain specified performance. In this way, braking torque delivered is neither higher nor lower than design values.
- 8.4.(b):** Note: Linings thicker than the original will contact the wheel only at their tips.
- 8.4.(b).(i):** Note: Linings thinner than the original will contact the wheel only across their middle.
- 8.4.(c):** Where re-lined shoes are used, check that shoe castings are not damaged, worn or distorted.
- 8.4.(d):** Check that the brake is square to the wheel for optimum contact between the lining and the wheel.
- 8.5: Energize the brake release magnet. Check the clearance between each brake shoe and the brake wheel.
- 8.6: After performing all mechanical checks, proceed with caution, as follows:
- 8.6.(a):** Remove any drum chocks on a hoist application.
- 8.6.(b):** To test the brake, energize the brake magnet for one short jog. If the brake fails to stop and hold the motion stationary, repair or re-adjust the brake as necessary. Visually inspect the brake during operation to ensure complete release. If successful, continue with longer duration jogs until confident that the brake is operating satisfactorily.
- 8.7: Make sure that wheel run-out is within allowable values given in Table 2. Lining drag produces unnecessary wheel heat and lining deterioration. Every operational test should include verification of brake wheel run-out as follows.
- 8.7.(a):** At all speeds, verify that the linings are clear of the wheel. Take steps to correct wheel run-out, imbalance or the effects of critical speed.
- 8.7.(a).(i):** Excessive run-out can cause unnecessary wheel heating which may cause "glazing" and loss of torque.
- 8.7.(b):** If necessary, check brake wheel run-out as follows:
- 8.7.(b).(i):** Use a dial gauge to check that wheel surface run-out does not exceed 0.001" per inch of brake wheel diameter. For example, run-out for a 13-inch brake wheel should not exceed 0.013." Refer to Table 2 for other brake wheel run-out values. Use a dial gauge and lift the brake wheel to check bearing play.

## Chapter 9.0: Maintenance and Repair

NEMA Standard ICS 9-1993, Part 1 recommends that brakes be fitted with new or re-lined shoes before the lining material is worn excessively. Table 5 specifies minimum operating lining thickness, and running clearance for size 6" to 16" brake wheels.

9.1: Replacing the Brake Shoes

9.2: On a hoist lower the load to the floor and disconnect the load from the bottom block.

**9.2.(a):** Remove brake shoes as follows:

**9.2.(a).(i):** Reset the bottom block on the floor, or on a suitable support. Chock drum to prevent rotation of the drum.

**9.2.(a).(ii):** Refer to Fig. 5. Slacken off nut (C); disengage spring locating collar (D); and swing the brake rod (F) up clear of the brake link arms.

**9.2.(a).(iii):** Remove shoe pins (N) and replace the special retaining clips to avoid loss. Open out the brake link arms.

**9.2.(a).(iv):** Lift out the worn shoes.

**9.2.(b):** Install new shoes as follows:

**9.2.(b).(i):** New shoes need more clearance. Run the shoe equalization setting screws (L) down as far as they will go to provide additional shoe to wheel clearance.

Figure 5

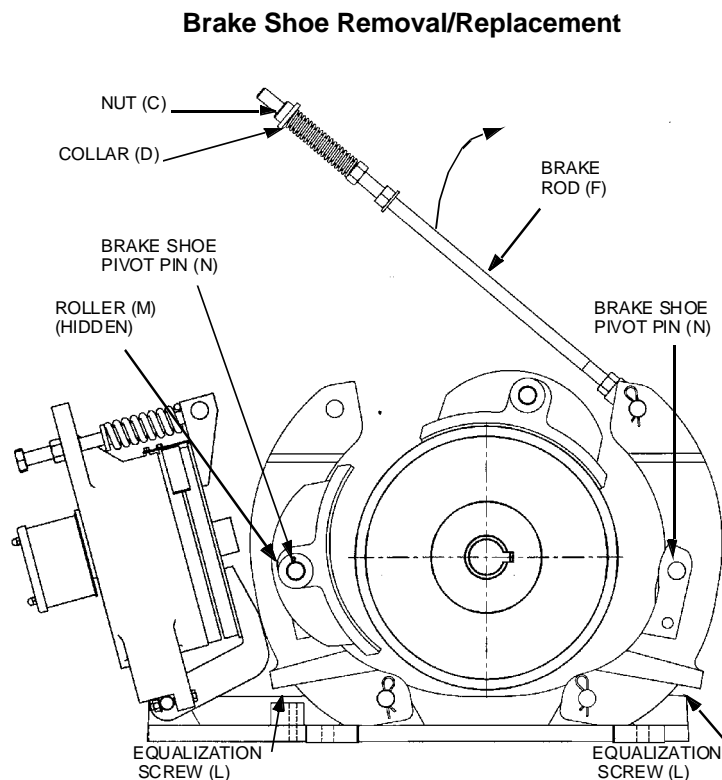

**9.2.(b).(ii):** Before installing the shoes, check that the lining surface will be true to the wheel when the shoe is installed. Carefully check lining contact with the wheel. Remove any high spots with emery paper to ensure 60% contact.

**9.2.(b).(iii):** Install the new shoe assemblies in the reverse order. Take care to replace roller (M) on the shoe pivot pin inside the magnet end link arm. This roller transmits torque spring force via the magnet armature to the brake link arm. Reinstall the brake rod etc.

**9.2.(b).(iv):** Newly lined shoes seldom fit perfectly with the contour of an existing brake wheel, particularly if the wheel is worn or under sized. If the brake has been moved, realignment of the brake with the wheel may be necessary. Refer to the topic "Brake Installation" for the correct alignment and bedding procedure.

**9.2.(b).(v):** Re-apply the brake and make all adjustments covered in Chapter 6.

**9.2.(b).(vi):** Adjust the magnet armature air gap.

**9.2.(b).(vii):** The torque spring setting will need adjustment only if it has been disturbed.

**9.2.(b).(viii):** Adjust brake shoe clearance as instructed in Chapter 6.

**NOTE: The brake can be damaged if the brake shoes are not accurately aligned. Do not operate the brake unless the brake shoes are in their normal position and all mounting hardware is properly installed.**

**9.2.(c):** Test the operation of the brake as instructed in Chapter 8.

### 9.3: Removing The Electro-Magnet

**9.3.(a):** Lower the load to the floor and disconnect the load from the bottom block.

**9.3.(b):** Reset the bottom block on the floor, or on a suitable support. Chock the drum to prevent rotation.

**9.3.(c):** Disconnect and remove electrical wiring and conduit to the brake magnet.

**9.3.(d):** Release the brake before attempting to remove the electro-magnet assembly. see Chapter 6: "Releasing the Brake."

**9.3.(e):** Secure or support the magnet assembly before attempting to remove the pivot pin.

**9.3.(f):** Refer to Fig. 6 and remove the pivot pins, etc. which secure the magnet assembly to the base.

**9.3.(g):** Remove the magnet assembly using appropriate lifting devices.

Figure 6

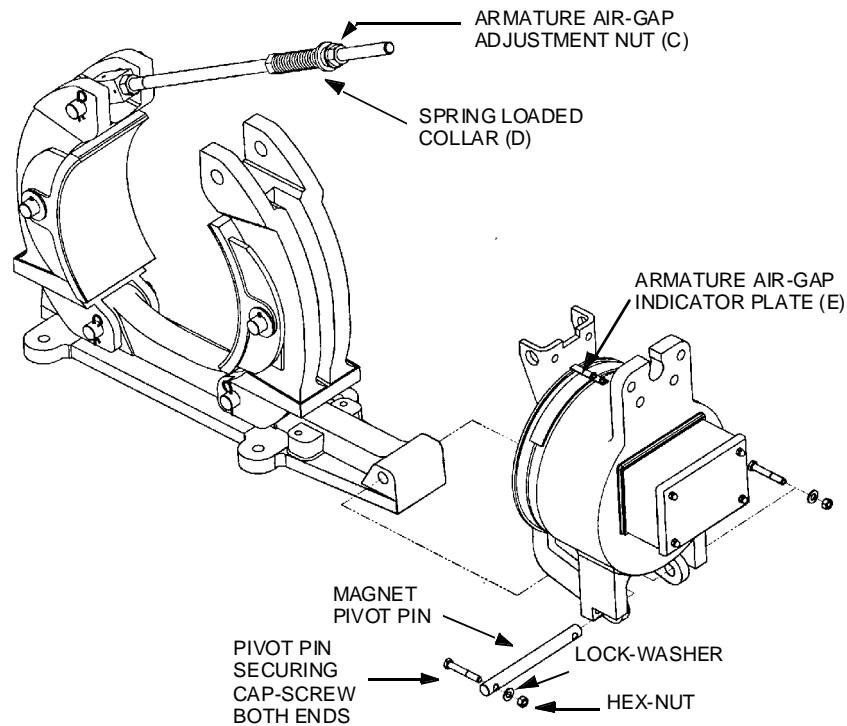

9.4: Re-Installing The Electro-Magnet

**9.4.(a):** Before re-assembling the magnet to the brake, check for wear on the pivot pin bores.

**9.4.(b):** Use appropriate lifting devices to position the magnet assembly on the base.

**9.4.(c):** Re-install the correct base-to-magnet pivot pin, etc. Securely replace all hitch pins. See Fig. 6.

**9.4.(d):** Re-connect the wiring, as required, and replace the terminal box cover.

**9.4.(e):** Review all adjustments; correct as necessary. See Chapter 6.

**9.4.(f):** Test operation of the brake as described in Chapter 8.

9.5: Re-lining The Brake Shoes

**We do not recommend that shoes be re-lined in the field. New bonded shoe assemblies can be ordered as repair parts. Factory rebuilt shoes are also available from Magnetek. Under this program, credit will be allowed for old shoes in usable condition.**

9.6: Removal and Installation of Motor and Brake Wheel

**9.6.(a):** It is possible to remove the top rod and lift out the complete drive motor and brake wheel assembly, as a unit, as follows:

**9.6.(a).(i):** Refer to Fig. 5. Remove both equalization screws. Back off nut (C); withdraw spring loaded collar (D) and swing the brake rod (F) up clear of the brake link arms.

**9.6.(a).(ii):** To allow space for the wheel to pass it may be necessary to remove both shoe assemblies. If so, remove shoe pins (N), etc. The brake shoes can now be taken out.

**9.6.(a).(iii):** Remove the motor and brake wheel by lifting straight up until the wheel clears the brake links.

**9.6.(b):** Re-install the motor and brake wheel by lowering it into place.

**Brake wheel to drive shaft installation is beyond the scope of this manual. Consult instruction by others.**

**9.6.(c):** Re-install the shoe assemblies in the reverse order. Take care to replace pivot tension springs and roller pin (M).

**9.6.(d):** Re-attach to the brake rod assembly.

**9.6.(e):** Verify the brake is still properly centered over the wheel; correct as required. Refer to the topic "Brake Installation" for detail.

**9.6.(f):** Review all adjustments; correct as necessary. See Chapter 6.

**9.6.(g):** Perform a full operational test of the brake, as described in Chapter 8.

#### 9.7: Inspection

**9.7.(a):** Maintenance and inspection periods depend on operating conditions. Wear will be more rapid when the linings are new and the high spots are wearing down. After the initial wear, records should be established by the user based on experience for the particular application.

**9.7.(b):** High duty cycle applications obviously require more frequent inspections than brakes operating on low duty cycle applications.

**9.7.(c):** In either case, Magnetek recommends a general inspection once a month, or every 100 hours of operation, whichever comes first.

**9.7.(d):** At the established inspection period, check brake shoe lining thickness. If the measured thickness at the center point of shoe curvature of either lining is equal to, or less than, 1/16", replace or reline both brake shoes.

**9.7.(e):** Verify that the electrical system is intact.

**9.7.(f):** Check that the brake wheel is secured to the shaft, and that the braking surface is in acceptable condition.

**9.7.(g):** Check that the brake mounting bolts are secure.

**9.7.(h):** Verify that the magnet armature air gap and brake shoe clearance setting are within specifications.

**9.7.(i):** Once set correctly, the torque springs require no further adjustment; they automatically reset to specification each time the air gap is re-adjusted for lining wear.

**9.7.(j):** Check for signs of wear on the various pivot pins, and that all cotter pins are intact.

**9.7.(k):** Make any repairs or adjustments that are necessary for correct brake system operation.

**9.7.(l):** Evaluate the brake wheel run-out at full speed. Refer to the topic “Operational Test”.

9.8: Lubrication

**9.8.(a):** Pivot pins are pre-lubricated at the factory. Mating surfaces are selected to be self-lubricating. Pivot pins are selected bronze alloy and mate with holes in castings. A light coat of “NEVER SEIZE” will prevent corrosion and provide the necessary lubrication. Excessive lubrication tends to attract dust and eventually accelerate wear.

9.9: Brake Adjustment

**9.9.(a):** Wear is accelerated when the linings are new and high spots are wearing down. Re-adjust the magnet armature air gap soon after the brake is put into service.

**9.9.(b):** The magnet armature air gap increases as linings wear. Carry out periodic maintenance to reset the air gap to specifications before the maximum gap stamped on the indicator plate is reached, otherwise the armature may not pull in and release the brake under certain conditions. See Chapter 6 for description.

**9.9.(c):** In severely dirty applications, particularly where the dust is magnetic, the magnet armature air gap may pack with dust. Dismantle as necessary and clean the magnet pole and armature faces.

## Chapter 10.0: Replacement Parts

Following any adjustment, maintenance or repair on the brake, fully test its operation as described in Chapter 8.

### 10.1: Brake Lining Replacement

Table 5

Wheel Diameter (Inches)	Maximum RPM	Minimum Wheel Dia. (Inches) (1)	Lining Thickness (Inches) (2)	
			Riveted (3)	Bonded
4 <sup>(4)</sup>	5000	3.94	0.010	0.016
6 <sup>(4)</sup>	5000	5.94	0.010	0.016
8 <sup>(5)</sup>	5000	7.94	0.010	0.016
10 <sup>(5)</sup>	4000	9.92	0.010	0.020
13 <sup>(5)</sup>	3300	12.90	0.010	0.026
16 <sup>(5)</sup>	2600	15.87	0.015	0.032

(1) Minimum after re-machining.  
(2) Minimum permissible prior to replacement.  
(3) Above rivet head at maximum wear point.  
(4) 4" to 6" Brakes are not covered by NEMA Standards.  
(5) 8" to 16" Brakes per NEMA Standard ICS 9-1993, Part 1.

10.2: As a general guide, Magnetek recommends that brake linings be replaced when the linings wear down to 1/16" minimum thickness.

10.3: Table 5 states the minimum permissible brake lining thickness prior to replacement. Information for wheel sizes 8" to 16" conforms to NEMA standard ICS 9-1993, Part 1; Electro-magnetic Brakes. The information for the 4" to 6" brakes is provided by Magnetek. Table 5 covers both bonded and riveted type linings.

**10.3.(a):** See Chapter 9 covering procedures for brake shoe replacement and electro-magnet removal and re-installation.

**10.3.(b):** For other parts replacement, or complete disassembly and rebuild, refer to the exploded view attached to this manual.

**10.3.(c):** After a brake has been repaired or rebuilt, perform a complete adjustment of the brake as per Chapter 6, "Adjustment".

10.4: Ordering Parts

**10.4.(a):** Refer to the drawing of the Exploded View and the Bill of Material forming part of this manual. Use only genuine Mondel parts to ensure optimum brake performance.

## **Chapter 11.0: Long Term Storage**

- 11.1: If a brake assembly will not be installed immediately, it can be stored indoors in a dry location indefinitely, or outdoors for a reasonable time if adequately protected from moisture and corrosive atmosphere. The brake assembly must always be protected from direct exposure to the elements unless specifically treated at the factory for use in that environment. Covering with plastic sheeting is not acceptable unless provision is made to prevent condensation under the plastic.
- 11.2: During storage, rust may form on the surface of the brake wheel. This is no cause for concern, nor is it necessary to clean the wheel before placing in service. The first few brake applications will re-polish the wheel.
- 11.3: If a type SA1 brake is to be removed and stored temporarily, prepare as recommended above. In addition, clean the complete assembly. Painted surfaces should be touched up or repainted as appropriate.

**11.3(a):** Do not allow paint to contaminate the pivot points, magnet core or armature face, brake wheel or linings. Do not paint over, or remove, data plates and labels.