



---

# RVS-DX Digital Soft Starter Instruction Manual

---



**MAGNETEK**  
UNCOMMON POWER

**Power Control Systems**

April 1, 2004  
Part Number: 188-10130  
© Copyright 2004 Magnetek

## **Contents:**

Disclaimer of Warranty .....	ii-iii
------------------------------	--------

### **Chapter1: Introduction**

Overview .....	1-3
Starter Selection .....	1-3

### **Chapter 2: Installation**

Physical Installation.....	2-3
Enclosures .....	2-3
Built-in Bypass After Acceleration.....	2-4

### **Chapter 3:Terminals & Wiring**

Control Terminals .....	3-3
Typical Control Wiring .....	3-4
Inside the Delta Operation.....	3-5

### **Chapter 4: Control Layout**

Digital Operator Layout.....	4-3
Extended Parameter Settings.....	4-6

### **Chapter 5 : Features**

Start/Stop Features.....	5-3
Motor Protection Features .....	5-7

### **Chapter 6: Parameters**

Parameter Flowchart .....	6-3
Parameters .....	6-6

## **Chapter 7: Start-Up Procedure**

Start-Up Procedure ..... 7-3

Start-Up Procedure with Pump Control ..... 7-5

## **Chapter 8: Troubleshooting**

Troubleshooting ..... 8-3

## **Appendix A: Technical Data/Specifications**

Technical Data/Specifications ..... A-3

## **Appendix B: Dimensional Drawings**

Dimensional Drawings ..... B-3

## **Appendix C: Fuse Selection**

Fuse Selection Table ..... C-3

©2004 MAGNETEK

All rights reserved. This notice applies to all copyrighted materials included with this product, including, but not limited to, this manual and software embodied within the product. This manual is intended for the sole use of the persons to whom it was provided, and any unauthorized distribution of the manual or dispersal of its contents is strictly forbidden. This manual may not be reproduced in whole or in part by any means whatsoever without the expressed written permission of Magnetek.

## ***DANGER, WARNING, CAUTION and NOTE* Statements**

*DANGER, WARNING, CAUTION, and Note* statements are used throughout this manual to emphasize important and critical information. You must read these statements to help ensure safety and to prevent product damage. The statements are defined below.



### **DANGER**

*DANGER* indicates an imminently hazardous situation which, if not avoided, will result in death or serious injury. This signal word is to be limited to the most extreme situations.



### **WARNING**

*WARNING* indicates a potentially hazardous situation which, if not avoided, could result in death or serious injury.



### **CAUTION**

*CAUTION* indicates a potentially hazardous situation which, if not avoided, could result in minor or moderate injury. It may also be used to alert against unsafe practices.

*NOTE:* A *NOTE* statement is used to notify people of installation, operation, programming, or maintenance information that is important, but not hazard-related.

## Disclaimer of Warranty

Magnetek, hereafter referred to as Company, assumes no responsibility for improper programming of a soft starter by untrained personnel. A soft starter should only be programmed by a trained technician who has read and understands the contents of this manual. Improper programming of a soft starter can lead to unexpected, undesirable, or unsafe operation or performance. This may result in damage to equipment or personal injury. Company shall not be liable for economic loss, property damage, or other consequential damages or physical injury sustained by the purchaser or by any third party as a result of such programming. Company neither assumes nor authorizes any other person to assume for Company any other liability in connection with the sale or use of this product.



### **WARNING**

Improper programming of a soft starter can lead to unexpected, undesirable, or unsafe operation or performance.

---

### **IMPORTANT**

---

1. Read this manual carefully and follow its instructions before operating equipment.
  2. Installation, operation, and maintenance should be in strict accordance with this manual, national codes and good practice. Installation or operation not performed in strict accordance with these instructions will void manufacturer's warranty.
  3. Disconnect all power inputs before wiring or servicing the equipment.
  4. After installation, verify that no hardware (bolts, washers, etc.) have fallen into the power section.
- 

---

### **WARNING**

---

1. Internal components and printed circuit boards are at main potential when the RVS-DX is connected to main power. This voltage is extremely dangerous, and may cause death or severe injury if contacted.
  2. The control PCB employs CMOS ICs that are easily damaged by static electricity. Use proper electrostatic discharge (ESD) procedures when handling the control PCB.
  3. When the RVS-DX is connected to main power, even if control power is not connected and the motor is stopped, full voltage may appear on the RVS-DX's output terminals.
  4. RVS-DX must be grounded to ensure correct operation, safety, and to prevent damage.
  5. Power factor capacitors must NOT be connected to the output side of the RVS-DX.
-

---

**ATTENTION**

---

1. This product was designed for compliance with IEC 947-4-2 for class A equipment.
  2. RVS-DX are listed under UL508C.
-

*c h a p t e r* **1**

---

**Introduction**

This page intentionally left blank.

# Overview

The RVS-DX is a digital electronic soft starter, incorporating six SCR's to start a three phase squirrel cage induction motor by supplying a slowly increasing voltage, providing soft start and smooth stepless acceleration, while drawing the minimum current necessary to start the motor. The RVS-DX is equipped with internal bypass relays initiated by its microprocessor control (on units 31-310 amps).

Using the soft stop, the RVS-DX slowly reduces the motor voltage, thus softly stopping a high friction load. In applications where the inertia of a load would cause the motor to "free wheel"; the soft stop will not stop the motor any faster than the coast to stop.

## Starter Selection

Select the RVS-DX soft starter according to the motor's Full Load Amps. Also consider the following information:

Ambient Temp.	I start	Acc Time
40°C	300% In	30 Sec.
	350% In	20 Sec.
	400% In	5 Sec.

Maximum starts per hour: 4 starts per hour at maximum ratings up to 10 starts/hour for lightly loaded applications.

*NOTE: For very frequent starts (inching applications) the inching current should be considered the FLA.*

Supply Voltage (Line to Line): +10%–15%

Standard Supply Voltage: 220–240 volts  
460–500 volts  
575–600 volts

Special Order Voltage: 380–440 volts

*NOTE: All RVS-DX units are suitable for 50/60 Hz.*

Control Voltage: 110-120 volts (+10% -15%); 50/60 Hz (standard)  
220-240 volts (+10% -15%); 50/60 Hz

Max. FLA	Frame Size	Model Number	
		230/460 Volts*	575 Volt
8	A1	RVS-DX-8-D	RVS-DX-8-E
17		RVS-DX-17-D	RVS-DX-17-E
31		RVS-DX-31-D	RVS-DX-31-E
44		RVS-DX-44-D	RVS-DX-44-E
58	A2	RVS-DX-58-D	RVS-DX-58-E
72		RVS-DX-72-D	RVS-DX-72-E
85	A3	RVS-DX-85-D	RVS-DX-85-E
105		RVS-DX-105-D	RVS-DX-105-E
145	A4	RVS-DX-145-D	RVS-DX-145-E
170		RVS-DX-170-D	RVS-DX-170-E
210	A5	RVS-DX-210-D	RVS-DX-210-E
310		RVS-DX-310-D	RVS-DX-310-E
390		td	RVS-DX-390-D

\*Dual rated soft starters come pre-set for 460 volts. To set for 230 volts, simply change the rated line volt parameter in the main parameters (See Chapter 6-Parameters).

No control voltage required)

Approximate Dimensions and Weights				
Frame Size	Width (in.)	Height (in.)	Depth (in.)	Weight (lbs.)
A1	4.72	9.13	4.8	6.6
A2	5.08	10.83	7.15	11.5
A3	5.08	14.96	7.15	18.7
A4	6.77	14.96	7.54	27.5
A5	14.96	17.91	11.61	92.4

*c h a p t e r* **2**

---

**Installation**

This page intentionally left blank.

# Physical Installation

Location of the RVS-DX is important to achieve proper performance and normal operating life. The unit should be installed in an area where it will be protected from:

- Direct sunlight, rain or moisture
- Corrosive gases or liquids
- Vibration, airborne dust or metallic particles

When preparing to mount the RVS-DX, lift it by its base, never by the front cover. For effective cooling as well as proper maintenance, the RVS-DX must be installed on a flat, non-flammable vertical surface (wall or panel) using four mounting screws. There must be a minimum of 4.7 inches of clearance above and below the RVS-DX for sufficient airflow. A minimum of 1.2 inches of clearance is required on each side of the RVS-DX.

The protected chassis is rated to operate over a temperature range of -14°F (-10°C) to +122°F (40°C). Relative non-condensing humidity should not exceed 93%.

## Enclosures

If the RVS-DX is to be mounted in a customer supplied enclosure, the heat dissipation should be considered when sizing an enclosure. Maximum surrounding air temperature should not exceed 40°C. Since the RVS-DX does have built in bypass after acceleration, the watts loss is minimized. The RVS-DX watts loss is approximately 0.4 x the FLA in watts. (example: for a motor of 100A, expect watts loss of the starter to be 40 watts.) Internal enclosure heating can be reduced by using additional ventilation.

## Built in Bypass After Acceleration

The bypass after acceleration allows the RVS-DX to control the motor during starting and stopping for smooth, step-less acceleration and deceleration. However, once up to full voltage the RVS-DX is bypassed to reduce the watt loss.

The RVS-DX incorporates internal bypass relays allowing current flow through the SCR's only during the soft start process. At the end of the soft start, the built-in relays bypass the SCR's and carry current to the motor. Upon stop signal, or in case of fault, all three bypass relays will open and stop the motor. When the decel time is set to allow soft stopping, upon stop command, the bypass relays will open immediately and the current will flow through the SCR's. The voltage will then be reduced slowly and smoothly to zero.

RVS-DX units rated 31-310 amps have built-in bypass.

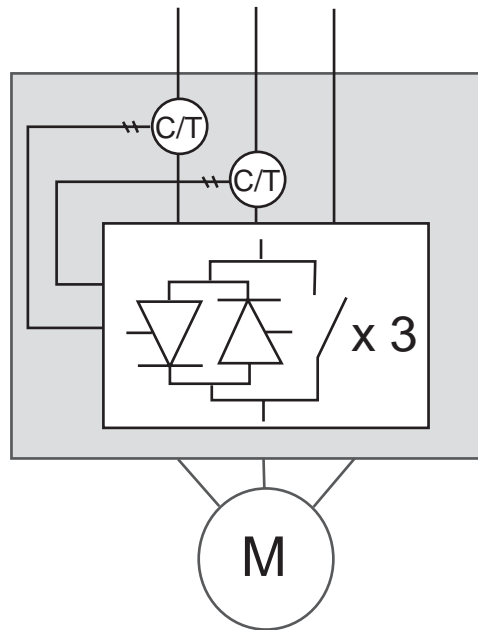

*c h a p t e r* **3**

---

**RVS-DX Terminals and Wiring**

This page intentionally left blank.

# Control Terminals

Terminal	Function	Description
A1 A2	Control Supply <i>(Note 1)</i>	120V control power must be connected at terminals A1 & A2.
B1	Start/Stop	Input from a N.O. maintained contact. Connect terminals A2 & B1 to start, and open to stop.
C1	Aux. Input	Input from a N.O. maintained contact. Connect terminals A2 & C1 to operate the function. <i>(Note 2)</i>
13 14	Auxiliary Output Contact <i>(Note 3)</i>	N.O. output contact can be set to Immediate or End of Acceleration. <i>(Note 3)</i> .
23 24	Fault Contact <i>(Note 4)</i>	N.O. contact closes upon any fault and returns to open position (after the fault has been removed) upon reset, or disconnection of main supply voltage.

1. The control power should be connected to A2, and control neutral to A1.
2. The auxiliary input can be programmed to operate as a reset, dual adjustment, generator starting, slow speed, slow speed reverse, or external fault (see chapter 6 on parameters to set the auxiliary input).
3. If the auxiliary output is set to Immediate, the contact closes at the start signal, and opens at the stop signal, end of soft stop fault, or at loss of voltage. If the auxiliary output is set to End of Acceleration, the contact closes after acceleration and opens at stop or soft stop signals, fault, or loss of voltage.
4. If the fault contact is set to fail-safe, the contact closes immediately when control power is connected, and opens upon fault.



## WARNING

*Do not use the fault contact to trip an upstream contactor. When the fault contact trips the upstream contactor, main voltage will be disconnected thus resetting the soft starter and the motor will restart immediately upon power being restored.*



## WARNING

*Start/stop with maintained contact. When the line contractor is operated by a maintained contact, if main supply voltage is lost, the motor will automatically restart upon voltage restoration. When resetting after a fault, the motor will restart upon the fault being reset.*

# Typical Wiring Diagram

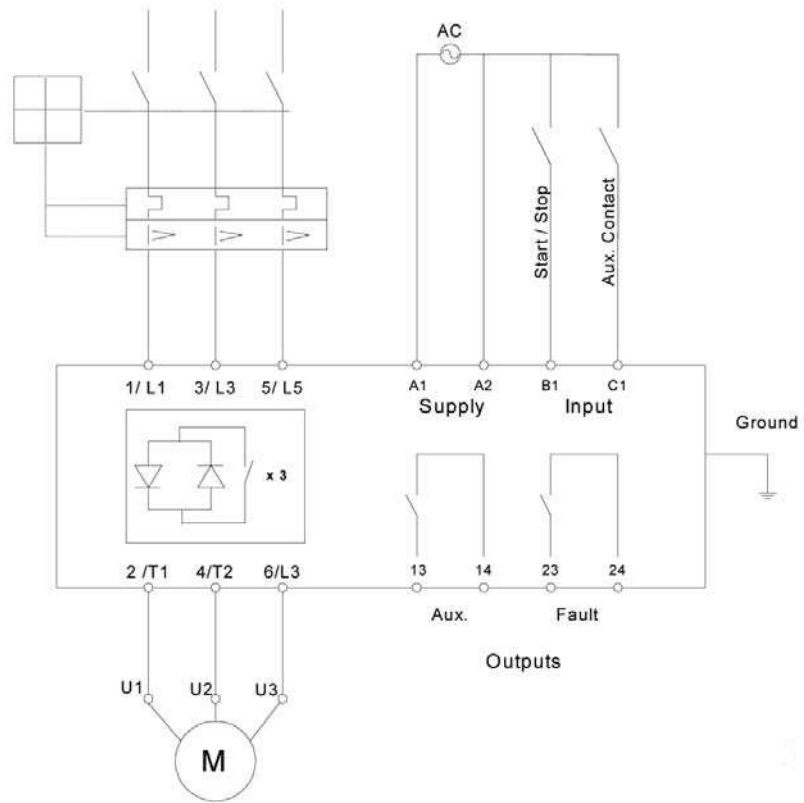

## Operating “Inside the Delta”

Using the RVS-DX soft starter “inside the delta” reduces the required soft starter rating by 1.73 ( $\sqrt{3}$ ) factor. For example, for a 150 amp, 460 volt motor, the RVS-DX-170-D is selected to operate in standard “line” mode. However, for “inside the delta” mode ( $150 \text{ amp} \div 1.73 = 87 \text{ amps}$ ), the RVS-DX-105-D can be selected, thereby, reducing cost and physical space in the application.

The following programming parameters are disabled, once the ‘inside the delta’ is selected:

- Pulse Start
- Pump Curve selection (only standard curve available)
- Slow Speed and Slow Speed Reverse
- Phase Sequence

The motor rating for standard “Line” and “Inside the Delta” connections are show here:

<b>Model Number</b>	<b>RVS-DX FLA</b>	<b>HP at 460V for “Line”</b>	<b>HP at 460V for “Inside Delta”</b>
RVS-DX-8-D	8	5	7.5
RVS-DX-17-D	17	10	15
RVS-DX-31-D	31	20	32
RVS-DX-44-D	44	30	50
RVS-DX-58-D	58	40	68
RVS-DX-72-D	72	50	85
RVS-DX-85-D	85	60	100
RVS-DX-105-D	105	75	125
RVS-DX-145-D	145	100	170
RVS-DX-170-D	170	125	215
RVS-DX-210-D	210	150	250
RVS-DX-310-D	310	200	340
RVS-DX-390-D	390	300	515

*HP Ratings are approximate. The RVS-DX should always be sized by the motor full load amps for “line” starting and the motor FLA/1.73=soft starter FLA for “inside delta”.*

## Typical Wiring for Inside the Delta Operation:

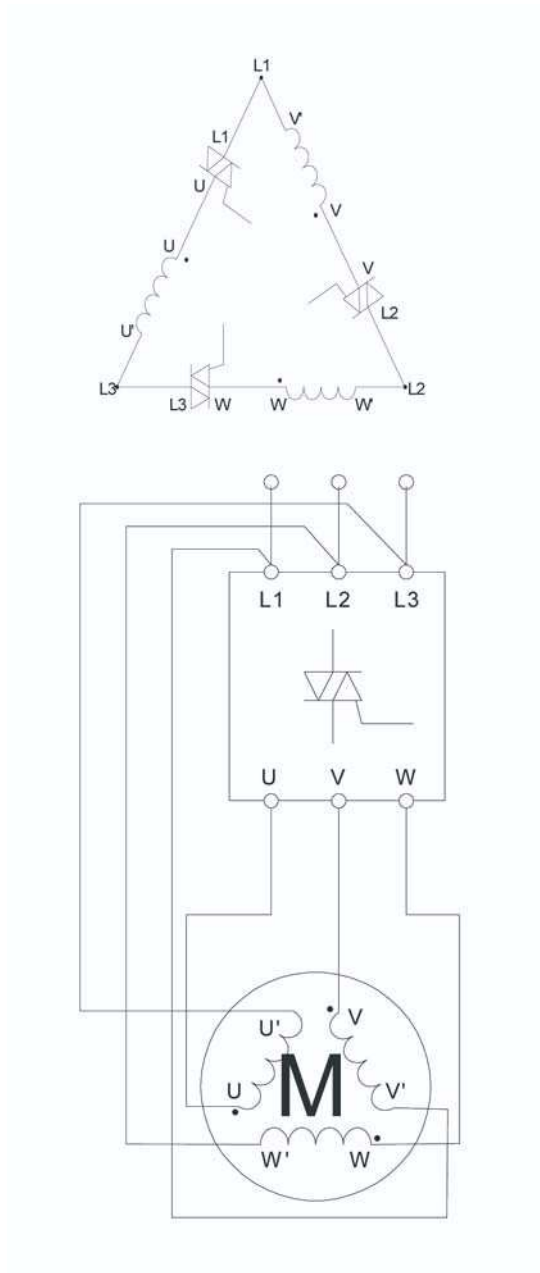

*c h a p t e r* **4**

---

**Control Layout**

This page intentionally left blank.

# Digital Operator Layout

## LED Arrangement:

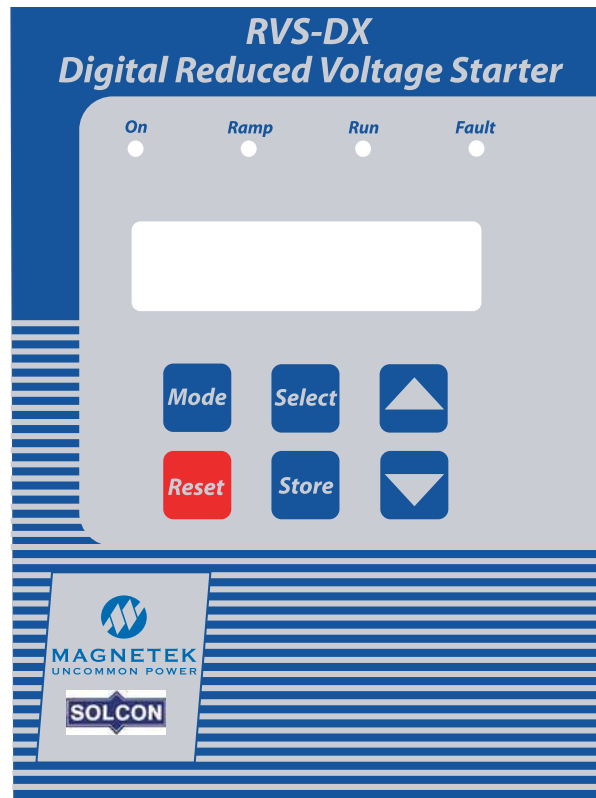

LED	Description
On	Lights when control power is connected to RVS-DX
Ramp	Lights during starting or soft stopping process (motor supply voltage is ramping up or down)
Run	Lights after completion of starting process (motor is receiving full voltage Flashes during slow speed operation)
Fault	Lights when any of the built-in protections cause a fault Flashes when Insulation Alarm relay is activated

## Keypad Arrangement

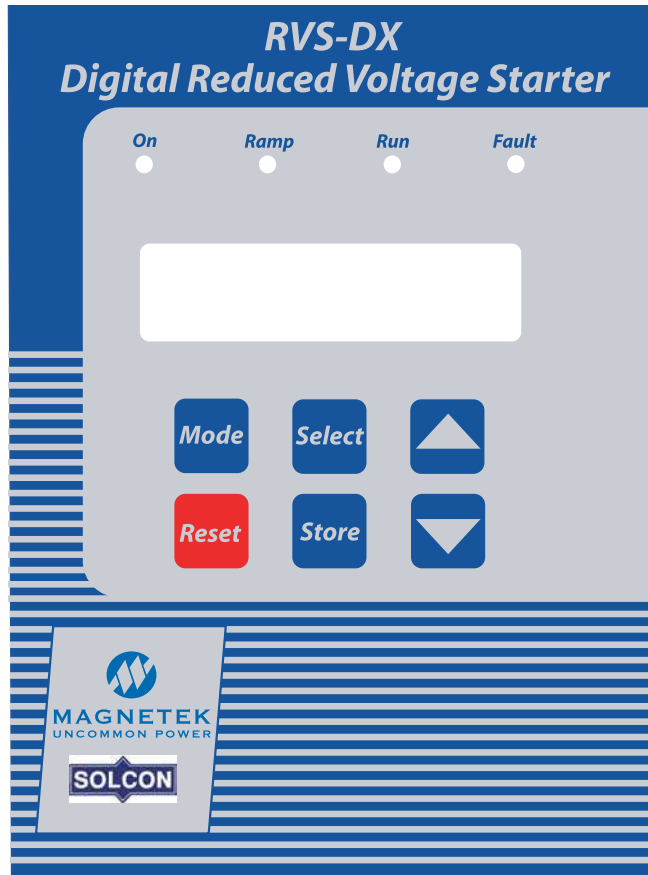

Keypad	Description
Mode	This button scrolls through the following modes: Display Only Main Parameters Start Parameters Stop Parameters Dual Adjustment Parameters Special Feature Parameters Fault Parameters I/O Programming Parameters Serial Communication Parameters Statistical Data
Select	This button scrolls through the various parameters
Up Arrow	Increases a parameter setting
Down Arrow	Decreases a parameter setting
Store	Saves the modified parameters. The “STORE” button will only save the modified parameter when pressed after the LCD display reads “STORE ENABLE”. The “STORE ENABLE” will follow the last parameter within each mode.
Reset	Cancels a displayed fault and allows restarting. The “Reset” button is only operable if the start command has been removed and the fault condition is cleared.

## LCD Display

The LCD display consists of two lines of alphanumeric characters, displaying: system parameters starter settings, motor current, fault indication and statistical data. The LCD can be displayed in four different languages: English, French, German and Spanish. The first line displays the function and the second line displays the setting (or measure value). Upon initiation of the starter the LCD will display the operating current as a percentage of motor FLA.

% Of Motor FLA

By pressing the “Mode Key” you can scan through all of the modes.

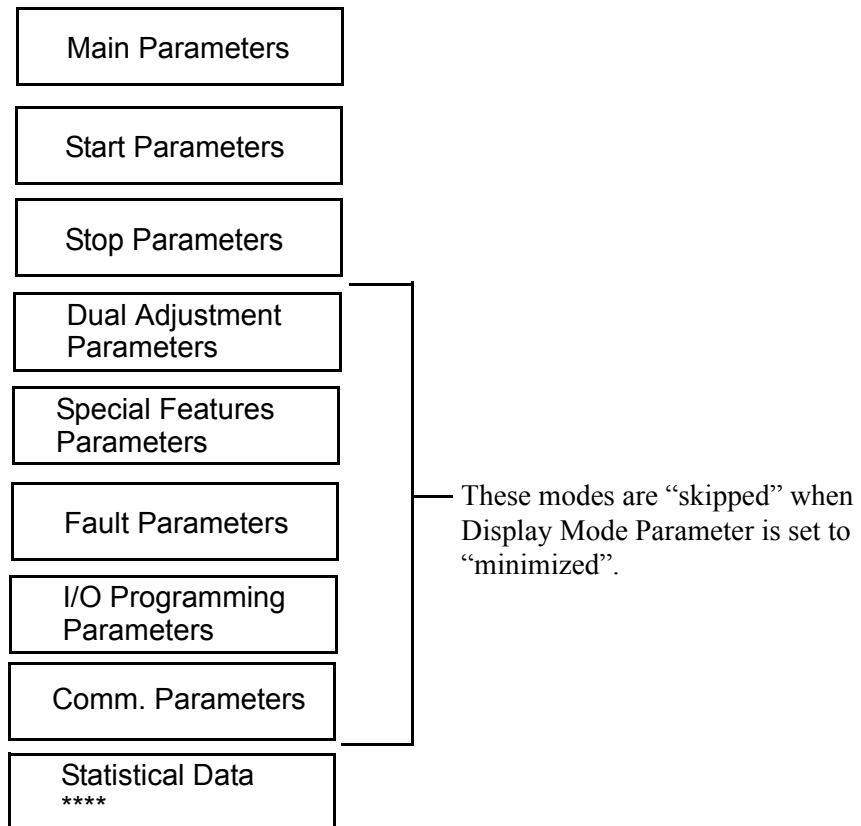

Stop at the required mode and press the “Select” button to review each parameter (function of the mode.)

When you have reached the required parameter, modify its value with up arrow and down arrow buttons.

To store the new parameters press the “Select” button until the “STORE ENABLE” message is displayed on the LCD, and then press the “Store” button. When new parameter data has been successfully saved, the LCD will read “DATA SAVED OK”.

## Extended Parameter Setting

The RVS-DX incorporates a parameter, “WIDER SETTINGS”, in the special Features Parameters. If the RVS-DX is significantly larger than your motor, you can enable the “wider settings” to extend parameter settings of the following:

### Extended Parameter Settings

<b>Parameter</b>	<b>Original Setting Range</b>	<b>Extended Setting Range</b>
Initial Voltage	10-50%	10-80%
Current Limit	100-400%	100-500%
Acceleration Time	1-30 seconds	1-90 seconds
Deceleration Time	0-30 seconds	0-90 seconds
Max. Start Time	1-30 seconds	1-250 seconds

*c h a p t e r* **5**

---

**Features**

This page intentionally left blank.

# Start/Stop Features

The RVS-DX incorporates many features that assist in starting and/or stopping various applications. These features are described within this section.

## Pump Control (Start Curves)

Induction motors produce peak torque up to three times the rated torque. This peak torque can occur towards the end of the starting process. In pump applications, this peak torque may cause high pressure in the pipes.

The RVS-DX incorporates four different starting curves. The start curve (curve 0) is the standard curve and the default. It is the most stable and suitable curve for the motor, preventing prolonged starting and motor overheating. Pump start curves (1, 2, and 3) automatically control the voltage ramp-up to reduce peak torque. The multiple starting curves are shown below:

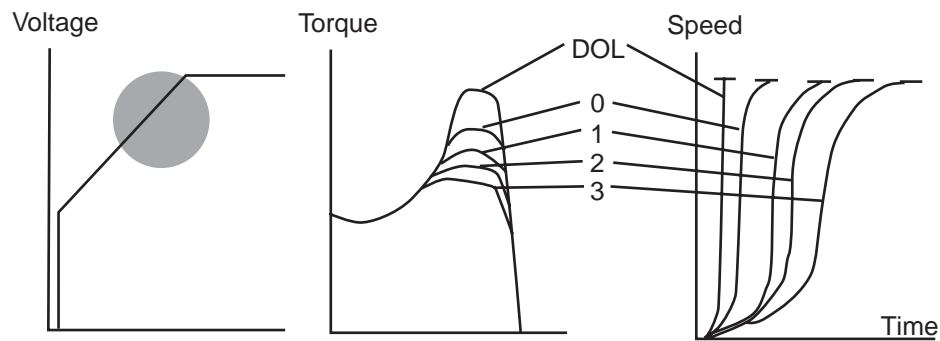

*NOTE: Always start with Start curve 0. If towards end of acceleration, peak torque is too high, proceed to curve 1, then 2 and 3 if necessary.*

## Tach Feedback (0-10 VDC)

The tach feedback provides linear acceleration and deceleration curves according to RPM feedback. Twelve tachometer gain levels can be selected for closed loop control for starting and stopping.

*NOTE: Always begin with minimum gain (0) and proceed with higher gain levels if required.*

## Pulse Start

The pulse start feature is used to break away high friction loads. High friction loads may require close to across the line starting torque for a very short duration of time. The pulse start feature accomplishes this with an 80% voltage boost (without current limit) for a period of 0.1 to 1 second.

After this pulse, the voltage is ramped down to the initial voltage setting where it begins ramping up again to full voltage.

## **Initial Voltage**

The initial voltage determines the motor's initial torque setting (the torque is directly proportional to the square of the voltage). The initial voltage can be set from 10 to 50%. The initial voltage also affects the inrush current and mechanical shock. An initial voltage setting that is too high may cause mechanical shock and a high inrush current. An initial voltage setting that is too low may result in a prolonged period of time before the motor begins to turn.

Generally, this setting should cause the motor to begin turning immediately after the start signal, while minimizing mechanical shock and inrush current.

## **Current Limit**

The current limit feature sets the highest current level that will reach the motor during the starting process. The current limit may be set from 100 to 400%. Once the present current limit value is reached the voltage will level off and only continue ramping up once the current is below the limit again.

If the current limit is set too high, there will be a greater current draw from the main power and a faster acceleration. If the current limit is set too low, the motor may be unable to reach full speed (the starter may trip on maximum start time).

Generally the setting should be high enough to start the motor without stalling.

## **Acceleration Time**

The acceleration time determines the motor's voltage ramp up time from initial to full voltage. The acceleration time can be set from 1 to 30 seconds.

The time it takes the motor to reach full speed may not necessarily be the same as the acceleration time. The following situations may override the acceleration time setting.

1. Since current limit overrides acceleration time, setting the current limit low will extend the acceleration time (but never to exceed maximum start time).
2. When the motor reaches full speed prior to reaching nominal voltage, acceleration time is overridden and voltage quickly ramps up to nominal. (This situation is common with lightly loaded motors.)
3. Using curves (1, 2, or 3) will prevent a quick acceleration time.

Generally this setting should be the minimum acceptable time.

## **Maximum Start Time**

The maximum start time is the maximum allowable time from start signal to end of acceleration. If the voltage does not reach nominal during this time period, the RVS-DX will trip, and the LCD display will read "LONG START TIME". The maximum start time is settable from 1 to 30 seconds.

## Stop Curves

For many applications, the load torque decreases in a square relation to the speed. In these applications, reducing the voltage will reduce the torque and the motor will smoothly decelerate to a stop. With these applications the standard stop curve (0) will be adequate. The stop curve (0) reduces the voltage linearly from nominal to zero.

In some other applications (namely pumps), a considerable amount of the torque is constant and does not decrease with speed. In these applications the motor torque could fall below load torque during stopping, causing the motor to stall. By using stop curves (1, 2 or 3) the motor will smoothly decrease to zero speed and prevent the stall condition.

The stop curves are shown in the graph below:

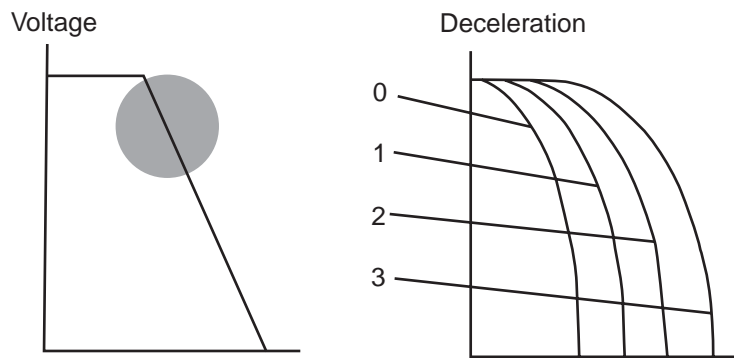

*NOTE: Always begin with Stop Curve 0. If your motor stalls quickly, instead of slowly decreasing its speed then try selecting stop curve 1, then 2 and then 3 if necessary.*

## Deceleration Time (Soft Stop)

The deceleration time is used for controlled deceleration of high friction loads. When the soft stop is initiated the RVS-DX's output voltage is gradually ramped down. The deceleration time is programmable from 0 to 30 seconds.

## Final Torque

The final torque setting determines the torque towards the end of the soft stop. If the motor stalls while current is still flowing and the speed has softly been reduced to zero, increase the final torque setting to prevent unnecessary motor heating. The final torque can be set from 0 to 10 (maximum).

## Dual Adjustment

The dual adjustment feature allows the RVS-DX to have two sets of starting characteristics. This feature is very beneficial in applications where the motor may be starting loaded or unloaded. There is also a dual setting for motor FLA, which allows the RVS-DX to operate a two speed motor with adequate motor protection.

The RVS-DX is transferred to the dual adjustment settings by connection of control power to terminal C1, when it is programmed to Dual Adjust. The dual adjustment parameters are:

IV	Initial voltage	10-50%
CL	Current limit	100-400%
AT	Acceleration time	1-30 seconds
DT	Deceleration time	0-30 seconds
FLA	Motor FLA	8-390 Amps depending upon RVS-DX's FLC.

## Slow Speed Torque

The slow speed torque determines the torque while the motor is operating at 1/6 of the nominal speed. The slow speed torque can be set from 1 to 10.

## Maximum Slow Speed Time

The maximum slow speed time sets the allowable operation time that the RVS-DX can run at slow speed. The setting range is from 1 to 30 seconds.



### WARNING

*Operating current while motor is running at 1/6 speed is much higher than nominal current and motor ventilation is much weaker. Special precaution should be taken to prevent overheating while running at slow speed for long periods of time.*

# Motor Protection Features

The RVS-DX incorporates advanced microprocessor-based digital circuitry, which allows for sophisticated motor protection with digital accuracy. The motor protection features are covered in detail below.

## Too Many Starts

The “too many starts” feature allows programming of the maximum allowable starts during the “starting period”. The maximum amount of starts may be set from 1 to 10 starts within a 1 to 60 minute starting period.

## Start Inhibit

The start inhibit sets the time period which starting is disabled after a “TOO MANY STARTS” trip. The setting range is from 1 to 60 minutes.

*NOTE: When trying to start the motor before the “Start Inhibit” time has elapsed, the LCD will display “WAIT BEFORE ⇒ RESTART: xx MIN.”.*

## Maximum Start Time (Stall Protection)

The maximum start time will trip the starter if the motor does not reach full speed during the “Maximum Start Time”. The maximum start time is settable from 1 to 30 seconds.

## Electronic Fuse (Shear-pin)

The electronic fuse is used to protect the starter and motor from high current. The electronic fuse has two operating modes: one for during start, and one for during operation.

*During starting:* the starter trips when the current exceeds 850% of the motor FLA setting in 1 cycle or less.

*During operation:* (After acceleration period; “Run” LED will be on.) The starter trips when current exceeds the set current level of 200 to 850% in the programmed delay time.

*NOTE: The electronic fuse is not intended to replace fast acting fuses to protect SCR's.*

## Electronic Overload

The electronic overload becomes operational when the “RUN” LED is lit. The starter incorporates a thermal memory register which calculates heating minus dissipation of the motor. When the thermal memory fills up, the starter trips. The thermal register resets itself 15 minutes after the motor stops. The electronic overload is settable from 75 to 150% of motor's FLA. (Factory setting is 115%). The tripping time at 5xFLA is adjustable from 1 to 10 seconds, thus allowing a trip curve selection.

## Undercurrent

The undercurrent is operational when the motor is running. The starter trips when motor current drops below the set undercurrent trip level for a time period longer than the undercurrent delay time. The undercurrent setting ranges from (0=off) 20 to 90% of FLA, and the undercurrent delay ranges from 1 to 40 seconds.

## **Undervoltage**

The under voltage function becomes available only after the start signal. The starter will trip when the main voltage drops below the preset level for a time period longer than the under voltage delay. The under voltage trip setting ranges from 50-90%. The under voltage delay can be adjusted from 1 to 10 seconds. The under voltage fault can be auto reset. The auto reset must be enabled (see “Fault Parameters” in Chapter 6). The starter will re-check for the under voltage fault after 60 seconds and will auto reset as long as the run signal has been removed and the fault condition has cleared.

## **Overvoltage**

The overvoltage function becomes operational only after the start signal. The starter will trip when the main voltage rises above the preset level for a time period longer than the overvoltage delay. The overvoltage trip setting ranges from 110-150%. The overvoltage delay can be adjusted from 1 to 10 seconds.

## **Phase Loss (and under/over frequency)**

This protection feature is operational when the starter is energized. It is designed to protect the motor from single phasing. The starter will trip when 1 or 2 phases are missing for more than one second. The starter will also trip when frequency is less than 45 Hz or greater than 65 Hz. The phase loss fault can be auto reset. The auto reset must be enabled (see Fault Parameters). The starter will re-check for the phase loss fault after 60 seconds, and will auto reset as long as the run signal has been removed and the fault condition has cleared.

## **Phase Sequence**

The phase sequence function becomes operational as soon as the starter is energized. The phase sequence protection must be enabled (see “Fault Parameters” in Chapter 6). The starter will trip when the phase sequencing is wrong.

## **Low Slow Speed Time**

This function will trip the starter if the motor operates at slow speed (forward or reverse direction) longer than the Maximum Slow Speed Time (settable from 1 to 30 seconds). When the motor operates at slow speed it draws higher than nominal current (depending upon the slow speed torque setting), thus the motor and starter may overheat.

*NOTE: Always operate the motor at slow speed for the minimum possible time to prevent overheating.*

## **Wrong Connection**

The wrong connection protection indicates when the motor is not connected to the load terminals, or there is an internal disconnection in the motor winding.

## **Shorted SCR Protection**

The shorted SCR protection trips the starter when one or more SCRs have been shorted.

*NOTE: The soft starter will also trip on the “SHORTED SCR” if the main voltage is applied to the load terminals.*

## Heatsink Over Temperature

The starter has thermal sensors mounted on the heatsink, tripping the starter when the heatsink temperature rises above 85°C.



### WARNING

*The over temperature protection is designed to operate under normal conditions. The SCRs could overheat and fail before the heatsink reaches 85°C in the following situations: if the starter is run at extended low overload, with insufficient ventilation, sized improperly, started too frequently, or started frequently beyond maximum conditions.*

## Wrong Parameters

This protection indicates when incorrect parameters have been entered into the EEPROM. This can also occur when parameters have been incorrectly transferred from RAM to EEPROM.

## External Fault

The external fault becomes operational when the starter is energized. The starter will trip when the external (N.O.) contact on terminal C1 closes for more than 2 seconds. (Aux. input C1 must be programmed to External Fault).

## Fault and Reset

When any of the above protections cause the starter to trip, it locks in a fault condition and disables the SCR firing. The “Fault” LED illuminates, the LCD displays the fault message, and the fault contact (at terminals 23 & 24) closes.

The fault may be reset:

- via the “Reset” key on the keypad.
- via input at terminal C1.

*NOTE: The fault may only be reset once the fault condition has cleared and the run signal is removed.*

*NOTE: If fault occurs due to voltage outage, fault condition is latched and reappears upon voltage restoration.*

## Fault and Auto Reset

The phase loss and under voltage trips can be auto reset. The auto reset must be enabled. This is accomplished in the “Fault Parameters” mode. When auto reset is enabled, the faults due to phase loss and under voltage will receive a reset signal after a delay of 60 seconds. If the fault condition has cleared and the start signal has been removed, then the fault will be reset.

## **Additional Protection Available:**

### **Short Circuit Protection**

Protects the starter against a short circuit by SCR protection fuses. A chart can be found in Appendix C, page C-3.

### **Transient Protection**

Line transient voltages can cause a malfunction of the starter and damage to the SCR's. All RVS-DX soft starters have MOV's to protect from normal line voltage spikes.

*c h a p t e r* **6**

---

**Parameters**

This page intentionally left blank.

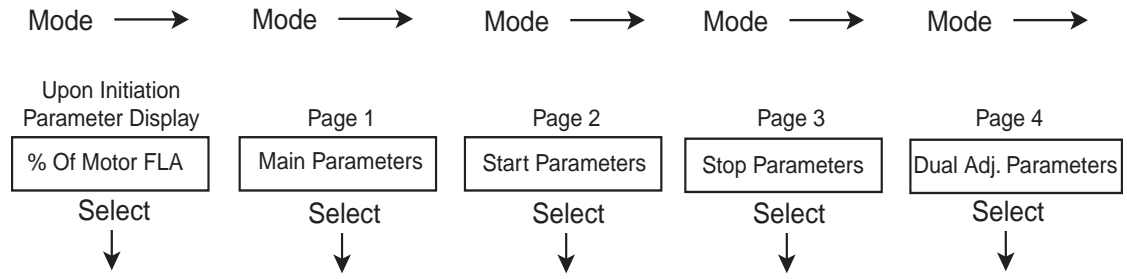

To Review All Parameters

Press   Keys To Change Parameter Value

Option Card Not Installed	Starter FLC 105 Amp	Soft Start Curve 0 (Standard)	Soft Stop Curve 0 (Standard)	When Prog. Input CI is set to Generator Start/Stop DA: (Generator) Parameters
	Motor FLA 105 Amp	Start Tacho Gain 0 (Min. Gain)	Stop Tacho Gain 0 (Min. Gain)	
BACK TO TOP	Connection Type Line	Pulse Time 0 Sec.	Dec. Time 0 Sec.	DA: Int. Current 100%
	Rated Line Volt. 460 Volt	Initial Voltage 30%	Final Torque 0 (Min)	DA: Cur. Limit 400% of FLA
	Undercurr. Trip 0% Of FLA	Initial Current 100%	Store Enable Stop Parameters	DA: Acc. Time 100 Sec.
	Under Curr. Delay 10 Sec.	Current Limit 400% of FLA	BACK TO TOP	DA: Dec. Time 0 Sec.
	O/C Shear Pin 850% Of FLA	ACC. Time 10 Sec.		DA: Motor FLA 105 Amp
	O/C Delay 0.5 Sec.	Max. Start Time 30 Sec.	Note: Available after initial voltage setting is above maximum level.	Store Enable D. Adj. Parameters
	Overload Trip 115% of FLA	Number of Starts 10		BACK TO TOP
	Overload Delay 4 Sec.-at 5 FLA	Starts Period 30 Min.		
	Undervolt. Trip 75%	Start Inhibit 15 Min.		
	Undervolt. Delay 5 Sec.	Store Enable Start Parameters		
	Overvolt. Trip 120%	BACK TO TOP		
	Overvolt. Delay 2 Sec.			
	Display Mode Minimized			
	Parameters Lock Not Locked			
	Store Enable Main Parameters			

BACK TO TOP

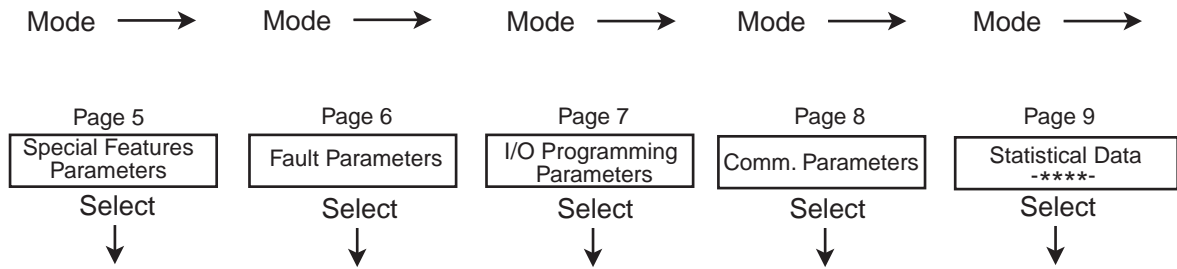

Press   Keys To Change Parameter Value

Slow Speed Torq. 8	Phase SEQ Y/N No	Prog. Input #C1 Remote Reset	Comm. Protocol Modbus	Last Strt Period No Data
Max. Slow Sp Time 30 Sec.	Insulation Alarm Off	Fault Relay Type Fault	Drive Number 0	Last Start Maxl No Data
Wider Settings Disabled	Insultation Trip Off	Prog. Aux. Relay Immediate	Baud Rate 9600	Total Run Time 0 Hourse
Store Enable En. Save & SL. Spd.	Auto Reset No	Relay On Delay 0 Sec.	Parity Check Even	Total # Of Start 0
<b>BACK TO TOP</b>	Thermistor Type PTC	Relay Off Delay 0 Sec.	Serial Link No. 248 (Off)	Last Trip No Data
	Thermistor Trip Off	Analog Output Normal	Store Enable Comm. Parameters	Trip Current 0% Of FLA
	Under Cur. Reset Off	Store Enable I/O Prog. Param.	<b>BACK TO TOP</b>	Total # of Trips 0
	Store Enable Fault Parameters	<b>BACK TO TOP</b>		Previous Trip 1...9 No Data
	<b>BACK TO TOP</b>			<b>BACK TO TOP</b>

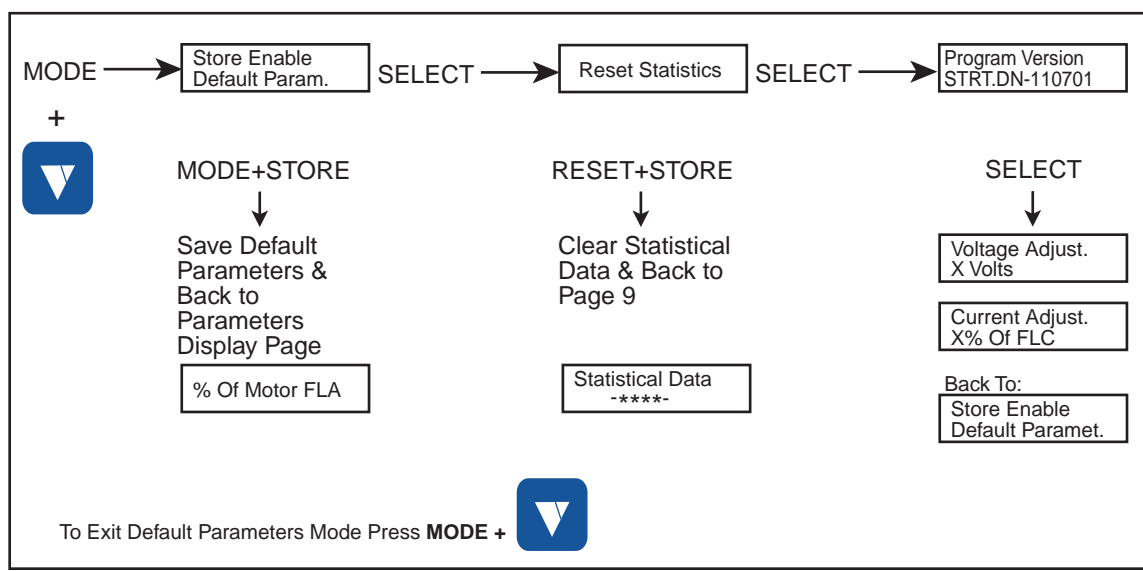

DISPLAY MODE				
Parameter	Description	Default Value	Range	Access
% of MOTOR FLA	The operating current as a % of the motor FLA	n/a	0-100%	Display only
MOTOR INSULATION*	Displays the insulation level of the motor's windings	Option card-not installed	?	Option card
THERMISTOR RES.*	Displays the motor thermistor resistance	Option card-not installed	?	Option card
ANALOG OUTPUT	Normal=analog output increases with increasing current Inverted=analog output decreases with increasing current	Option card-not installed*	Normal or Inverted	Option card

\* Requires an option card for these parameters to be displayed. If there are no option cards, the display will read, "Option Card—Not Installed".

SERVICE MODE		
Parameter	Description	Default
<b>Access:</b> To Enter or Exit the Service Mode press "Mode" & ▼ simultaneously.		
STORE ENABLE DEFAULT PARAMET.	Reset ALL parameters to default settings	Press "Mode" & Store simultaneously to save default parameters.
RESET STATISTICS	Reset statistical data.	Press "Reset" & "Store" simultaneously to reset statistic parameters.
PROGRAM VERSION	View the software version.	STRT.DN-xxxxxx
VOLTAGE ADJUST.	Factory calibration of phase to phase voltage.	xxx VOLT
CURRENT ADJUST.	Factory calibration of current.	xxx% of FLC

The User access level is always available. The maximized access is available when Display Mode parameter is set to maximized (changing available parameters from minimized to maximized level), but these parameters can only be changed when the RVS-DX is stopped.

MAIN PARAMETERS				
Parameter	Description/Function	Default Value	Range	Access
LANGUAGE	Language the Parameters are viewed in	English	English, French, German & Spanish	user
STARTER FLC	Full load current of the RVS-DX starter	(1)	8-390 amps	user
MOTOR FLA	Full load amps of the motor	(1)	50-100% of FLC setting	user
CONNECTION TYPE	Determines how the soft starter will be connected	LINE	Line or Inside Delta	user
RATED LINE VOLT.	Rated input line voltage	460	220-600 V	user
UNDERCURREN. TRIP	Under current trip setting	0%	0; 20-90% FLA	user
UNDERCURREN. DELAY	Under current delay setting	10	1-40 seconds	user
O/C—SHEAR PIN	Over current (shear pin) trip setting	850	100-850% FLA	user
O/C DELAY	Over current (shear pin) delay setting	.5	0-5 seconds	user
OVERLOAD TRIP	Overload trip setting	115	75-150% FLA	user
OVERLOAD DELAY	Overload delay setting at 500% of mtr FLA	4	1-10 seconds	user
UNDERVOLT. TRIP	Under voltage trip setting	75%	50-90%	user
UNDERVOLT. DELAY	Under voltage delay setting	5	1-10 seconds	user
OVERVOLT. TRIP	Over voltage trip setting	120%	110-125%	user
OVERVOLT. DELAY	Over voltage delay setting	2	1-10 seconds	user
DISPLAY MODE	Determines the parameters available to view.	MINIMIZED NOT LOCKED	Minimized or Maximized	user
PARAMETER LOCK	Locks all parameters from being changed.		Locked or not locked	
STORE ENABLE	Press 'Store' to save changes made to any of the Main Parameters			
MAIN PARAMETERS				

START PARAMETERS				
Parameter	Description/Function	Default Value	Range	Access
SOFT START CURVE	Determines the soft start curve	0(standard)	0-4	user
START TACHO GAIN	Allows tach. curves after scrolling through soft start curves		0-5	user(2)
PULSE TIME	Pulse (of 80% voltage) start time setting	0	0-1 second	user
INITIAL VOLTAGE	Initial voltage setting	30	10-50% (80%)(3)	user
INITIAL CURRENT	Allows initial current setting after scrolling through Initial Voltage settings		100-400%	user
CURRENT LIMIT	Current limit setting	400	100-400% (500%)	user
ACC. TIME	Acceleration time setting	10	1-30 sec. (90 sec.)(3)	user
MAX. START TIME	Maximum starting time setting	30	1-30 sec. (250 sec.)(3)	user
NUMBER OF STARTS	Maximum number of starts setting	10	off; 1-10	user
STARTS PERIOD	Period of time for max. number of starts	30	1-60 minutes	user
STARTS INHIBIT	Time Delay after max. number of starts were made	15	1-60 minutes	user
STORE ENABLE	Press 'Store' to save changes made to any of the Start Parameters			
START PARAMETERS				

STOP PARAMETERS				
Parameter	Description/Function	Default Value	Range	Access
SOFT STOP CURVE	Determines the soft stop curve	0 (standard)	0-4	user
STOP TACHO GAIN	Allows tach. curves after scrolling through soft stop curves		0-5	user (2)
DEC. TIME	Deceleration time setting	0	0-30 sec. (90 sec.) (3)	user
FINAL TORQUE	Final Torque setting	0	0-10	user
STORE ENABLE	Press 'Store' to save changes made to any of the Stop Parameters			
STOP PARAMETERS				

DUAL ADJUSTMENT PARAMETERS( <i>display mode set to maximized to access</i> )				
Parameter	Description/Function	Default Value	Range	Access
D. ADJ: GENERATOR PARAMETERS	Used for dual adjustment setting or generator settings.			maximized
DA: INIT. VOLT.	Initial voltage setting for dual adjust	30	10-50% (80%) (3)	maximized
DA: INIT CURRENT	Allows Initial current setting after scrolling through Initial Voltage settings.		100-400%	maximized
DA: CURR. LIMIT	Current limit setting for dual adjust	400	100-400% (500%) (3)	maximized
DA: ACC. TIME	Acceleration time setting for dual adjust	10	1-30 sec. (90 sec.) (3)	maximized
DA: DEC. TIME	Deceleration time setting for dual adjust	0	1-30 sec. (90 sec.) (3)	maximized
DA: MOTOR FLA	Motor FLA setting for dual adjust	STARTER FLC value	50-100% of FLC setting	maximized
STORE ENABLE	Press 'Store' to save changes made to any of the Dual Adjustment Parameters			
D.ADJ PARAMETERS				

SPECIAL FEATURES PARAMETERS ( <i>display mode set to maximized to access</i> )				
Parameter	Description/Function	Default Value	Range	Access
SLOW SPEED TORQ.	Slow speed torque level setting	8	1-10	maximized
MAX. SLOW SP TIME	Maximum slow speed operation time	30	1-30 sec. (250 sec.) (3)	maximized
WIDER SETTINGS	Enables extended parameter settings (p.4-6)	DISABLED	Enabled or Disabled	maximized
STORE ENABLE	Press "Store" to save changes made to any of the Special Features Parameters			
SPECIAL FEATURES				

<b>FAULT PARAMETERS</b> ( <i>display mode set to maximized to access</i> )				
<b>Parameter</b>	<b>Description/Function</b>	<b>Default Value</b>	<b>Range</b>	<b>Access</b>
PHASE SEQ. Y/N	Phase sequence trip setting	NO	Yes=on; No=off	maximized
INSULATION ALARM	Insulation alarm setting	OFF	off; 0.2-5 Mohm	maximized
INSULATION TRIP	Insulation trip setting	OFF	off; 0.2-5 Mohm	maximized
AUTO RESET	Auto reset 'on/off' setting	NO	Yes=on; No=off	maximized
THERMISTOR TYPE	Thermistor type setting	PTC	PTC, NTC	maximized
THERMISTOR TRIP	Thermistor trip setting	OFF	off; 0.1-10.0 Kohm	maximized
UNDER CUR. RESET	Under current auto reset time setting	OFF	10-120 min.; off	
STORE ENABLE	Press 'Store' to save changes made to any of the			
FAULT PARAMETERS	Fault Parameters			

<b>I/O PROGRAMMING PARAMETERS</b> ( <i>display mode set to maximized to access</i> )				
<b>Parameter</b>	<b>Description/Function</b>	<b>Default Value</b>	<b>Range</b>	<b>Access</b>
PROG.INPUT C1	Sets terminal C1 to: Dual adjust, generator mode, slow speed/reverse, external fault, remote reset.	Remote Reset	Dual Adjustment, Generator mode, slow speed/rev., external fault, reset	maximized
FAULT RELAY TYPE	Fault Fault-fail safe	Fault	Fault, Fault-Fail Safe	maximized
PROG. AUX. RELAY	Immediate or End of Accel	Immediate	Immediate, End of Accel.	maximized
RELAY ON DELAY	Time Delay before relays turns on	0	0-60 seconds	maximized
RELAY OFF DELAY	Time Delay before relay turns off	0	0-60 seconds	maximized
ANALOG OUTPUT	Normal=output increases with increasing current Inverted=output increases with decreasing current	Normal	Normal, Inverted	maximized
STORE ENABLE	Press 'Store' to save changes made to any of the I/			
I/O PROG. PARAM	O Programming Parameters			

<b>COMMUNICATION PARAMETERS</b> ( <i>display mode set to maximized to access</i> )				
<b>Parameter</b>	<b>Description/Function</b>	<b>Default Value</b>	<b>Range</b>	<b>Access</b>
COMM. PROTOCOL	Serial Communicaitons protocol selection	Modbus	Modbus, Profibus	maximized
DRIVE NUMBER	Drive number setting	0	0-999	maximized
BAUD RATE	Baud rate setting	9600	1200, 2400, 4800, 9600	maximized
PARITY CHECK	Parity Check setting	Even	Even, Odd, NO	maximized
SERIAL LINK NO.	Serial link number	248 (off)	1-248	maximized
STORE ENABLE	Press 'Store' to save changes made to any of the			
COMM.PARAMETERS	Communication Parameters			

STATISTICAL DATA				
Parameter	Description/Function	Default Value	Range	Access
LAST STRT PERIOD	Displays the last starting time in seconds	NO DATA		user
LAST START MAX-I	Displays the maximum current during last start	NO DATA		user
TOTAL RUN TIME	Displays the motor's hour counter since commencement or "Statistical Data" was reset.	0 HOURS		user
TOTAL # OF START	Displays total number of starts since commissioning or Statistical Data was reset	0		user
LAST TRIP	Describes the last fault	NO DATA		user
TRIP CURRENT	Displays the current at the last fault	0% of FLA		user
TOTAL # OF TRIPS	Displays the total number trips since commencement or "Statistical Data" was reset.	0		user
PREVIOUS TRIP -1	Describes the second last fault	NO DATA		user
PREVIOUS TRIP -2	Describes the third last fault	NO DATA		user
PREVIOUS TRIP -3	Describes the fourth last fault	NO DATA		user
PREVIOUS TRIP -4	Describes the fifth last fault	NO DATA		user
PREVIOUS TRIP -5	Describes the sixth last fault	NO DATA		user
PREVIOUS TRIP -6	Describes the seventh last fault	NO DATA		user
PREVIOUS TRIP -7	Describes the eight last fault	NO DATA		user
PREVIOUS TRIP -8	Describes the ninth last fault	NO DATA		user
PREVIOUS TRIP -9	Describes the tenth last fault	NO DATA		user

- (1) The FLC of the RVS-DX is pre-determined by the size of the power section. This setting can be adjusted lower, but not higher than the unit's rating. The Motor FLA setting is shown in amps. The default value will be matched to the FLC of the RVS-DX value, and can be modified from 50-100% of the FLC value.
- (2) Access to these parameters is available when dip switch 1.2 is ON.
- (3) The setting in parenthesis is the maximum setting of that parameter when the WIDER PARAMETERS is set to enable.

*c h a p t e r* **7**

---

**Start-Up Procedure**

This page intentionally left blank.

# Start-Up Procedure

*NOTE: If the motor is NOT connected to the load terminals, the “WRONG CONNECTION” fault indication will appear on LCD display.*

## Start-Up Procedure:

1. Connect an N.O. maintained push button from terminals B1 to A2.
2. Connect control power to terminals A1 and A2. (ON LED should illuminate.)
3. Review all parameters with “Mode” and “Select” keys and set parameters as required.
4. If necessary, return to Default Parameters (see page 6-5, “Service” Mode).
5. Connect main voltage to starter’s line terminals (L1, L2, and L3), and motor to load terminals (U, V, and W).
6. Set LCD to show “% OF MOTOR FLA”.
7. Press the “Start” button. If motor starts to turn shortly after the start signal proceed to Step 8. If the motor does not begin turning, increase the “Initial Voltage” and press “Start” again. When starting if initial inrush and mechanical shock are too high, decrease “Initial Voltage” setting, and proceed to Step 8.
8. Motor has begun to turn. If speed accelerates to nominal proceed to Step 9. If the motor speed does not accelerate to nominal, increase the “Current Limit” setting. If the current during acceleration process is too high, decrease the “Current Limit” setting, and proceed to Step 9.
9. Press the “Soft Stop” button and wait for the motor to stop.
10. Slightly increase the “Initial Voltage” and “Current Limit” settings to allow for load changes.
11. Press “Start” button and see that the motor “Acceleration Time” to full speed is as required.
12. If acceleration time is too short, increase “Acceleration Time” setting as required.
13. Check the total starting time and set “Max. Start Time” to approximately 5 seconds longer than the maximum time required to start the motor.
14. Repeat the same for the soft stop process.

*NOTE: When power factor correction capacitors are used, they must be installed on the soft starter line side.*

## Examples of starting curves

### Light Loads-Pumps, Fans, etc.

Initial Voltage (IV)-set to 30% (Factory Default)

Current Limit (CL)-set 300%

Acceleration Time (AT)-set 5 sec.

Voltage quickly increases to the Initial Voltage value and then gradually ramps-up to nominal. Current simultaneously and smoothly increases to reach Current Limit setting or less, before smoothly decreasing to the operating current. Motor speed will accelerate to full speed quickly and smoothly.

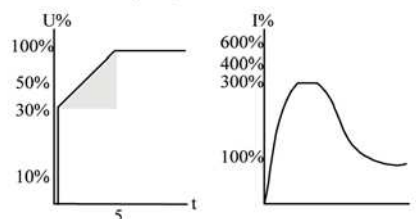

**High Inertia Loads-Fans, Centrifuges, etc.**

Initial Voltage (IV)-set 50%  
 Current limit (CL)-set 400%  
 Acceleration time (AT)-set 20 sec.

Voltage and current increase until current reaches “ Current Limit”. The voltage is held at this value until motor is close to nominal speed, then current will begin to decrease. The HRVS-DX continues to ramp-up the voltage until reaching nominal. Motor speed smoothly accelerates to full speed.

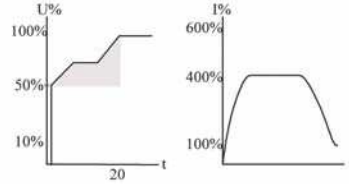

**Special starting-Using Dual Adjustment**

Using two starting characteristics, the starter will accelerate to the Dual Adjustment-IV reaching 100% current limit. After the Immediate Relay delay time, voltage to terminal C1 is switched off, using the standard characteristic to complete acceleration. This method of starting is useful to prevent initial high acceleration.

(Application: Submersible pumps, Drum fans with resonating frequency, etc.)

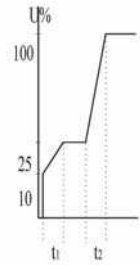

	Dual Adj. Par.	Standard Par.
Initial Voltage	10%	25%
Acceleration Time	t1=2-30 sec	t2=2-30 sec
Current Limit	200%	300-400%
Imm. Rel. ON delay	Tx=1-60 sec	—

# Start Up Procedure With Pump Control

## Starting Curve

1. Adjust main parameters as necessary (FLA, FLC, etc).
2. Set Starting Curve, Acceleration Time, Current Limit, and Initial Voltage to their default values (curve 0, 10 sec., 400% and 30% respectively).
3. Start the pump while watching the pressure gauge as the pump starts and look for overshooting (“Pressure Surge”) of the gauge needle above the target pressure. In case of over pressure, choose a peak torque reduction curve (Pump Control curve 1!).
4. Set Start Curve 1!, increase Acceleration Time to 15 sec. and reduce Current Limit to 350%. Start the pump and watch the pressure gauge while the pump starts.
5. In most cases, overshooting is reduced, if the overshoot persists, increase Acceleration time to 25 sec. (confirm with motor manufacturer) and try again.
6. If the overpressure persists, increase Starting Curve setting to 2!, or 3!, if necessary. Each increase in Starting Curve setting will reduce the Peak Torque, thus, reducing the overpressure and preventing the “Pressure Surge” during start.
7. To increase starting time above these maximums, employ “Extended Parameters Settings” (page 5-7).

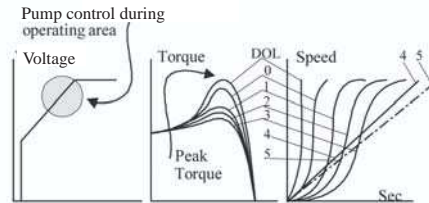

## Stopping Curve

1. Adjust main parameters as necessary (FLA, FLC, etc.)
2. Set Stop Curve and Deceleration Time, to their default values (curve 0, 10 sec., respectively).
3. Stop the pump, watching the pressure gauge and check valve as the pump stops. Look for overshooting (“Water Hammer”) of the gauge (abruptly stops the pump and the motor).
4. Select Stop Curve 1, increase Deceleration time to 15 seconds. Stop the pump and watch the pressure gauge and the rate of closing of the check valve as the pump stops. Abrupt stopping of the pump and motor will cause a loud audible noise emitted from the check valve.
5. In most cases, “Water Hammer” is reduced. If the “Water Hammer” persists, increase the time to 25 seconds (confirm with motor manufacturer) and try again.
6. If the “Water Hammer” persists, increase Stop Curve setting to 2!, or 3!. Each increase in stop curve will reduce the abrupt stop of the pump, thus, preventing the “Water Hammer” phenomenon.

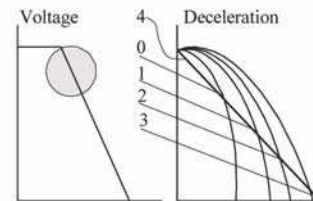

## Final torque during soft-stopping a pump motor

1. While decelerating, the check valve may close before Deceleration Time has elapsed, thus, allowing current to flow through stator winding causing unnecessary heat. Select Final Torque sensitivity to 1, and stop the pump, confirm that current stopped flowing through the motor shortly after the check valve closed.
2. If current still flows more than 3-5 seconds after check valve closure, increase Final Torque up to 10 if necessary, to stop current flow earlier.

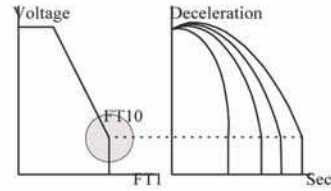

# *C h a p t e r* 8

---

## **Troubleshooting**

This page intentionally left blank.

# Troubleshooting

Upon fault the motor stops, “Fault” LED illuminates and fault relay operates. The LCD will display “Trip: fault description”.

Check “Statistical Data” for additional fault-related information.

<b>Fault</b>	<b>Description</b>
ALARM: INSULATION	(Optional) Initiates a signal when motor insulation level decreases below set level.
TRIP: INSULATION	(Optional) Trips the starter when motor insulation level decreases below trip value. Check motor and cable insulation level.
TRIP: THERMISTOR	(Optional) Trips the starter when motor’s thermistor resistance decreases below trip value. Check thermistor and cable’s resistance; check motor temperature near thermistor location.
TOO MANY STARTS	Trips the starter if the number of starts during “Start Period” exceeds the preset number. Wait until motor and starter cool down—according to “Start Inhibit” setting.
LONG START TIME	Trips the starter if output voltage does not reach nominal at the preset time. Check “FLA”, “FLC” and “Max. Start Time” settings. Increase “Initial Voltage”, “Current Limit” and “Max. Start Time” settings or decrease “Acceleration Time” as necessary.
O/C—SHEAR PIN	The electronic fuse trips the starter instantaneously when current exceeds 8.5 X FLA during starting or 200-850% during running. Check “FLA”, “FLC” settings, motor and cable connections. Check that the motor is not stalled.
OVERLOAD	Trips the starter when current exceeds the Overload Trip level and thermal register has filled up. Check “FLA”, “FLC” and “Overload” settings, and check the motor current. Wait 15 minutes to let the motor and stater cool down before starting.
UNDERCURRENT	Trips the starter when line current drops below the preset level for the preset time. Check “Undercurrent Trip” and “Undercurrent Delay” settings. Check line current through L1, L2, and L3.
UNDERVOLTAGE	Trips the starter when line voltage drops below the preset level for the preset time. Check “Undervoltage Trip” and “Undervoltage Delay” settings. Check line voltage through L1, L2 and L3.
OVERVOLTAGE	Trips the starter when line voltage rises above the preset level for the preset time. Check “Overload Trip” and “Overvoltage Delay” settings. Check line voltage through L1, L2 and L3.
PHASE LOSS	Trips the starter if 1 or 2 phases are missing. Check line voltages through L1, L2 and L3. Check that the frequency variations are between 45 to 65 Hz.
PHASE SEQUENCE	Trips the starter if input phase sequence is wrong. Check line phase sequence and if wrong, swap two wires on the line side. If the motor rotates in the wrong direction, swap two wires on the load side.
MAX. SLOW SP TIME	Trips the starter when operating at slow speed for extended period of time. Check that operation time at Slow Speed is shorter than the “Max. Slow Speed Time” setting. <i>NOTE: Motor and starter may overheat when operating at slow speed for an extended period of time.</i>
WRONG CONNECTION	Trips the starter when motor is not properly connected to load terminals.
SHORTER SCR	Trips the starter and prevents starting if one or more SCRs are short circuited or when motor windings are shorted. Check with an ohmmeter between L1-U, L2-V and L3-W, resistance > 20 KΩ  SCRs may fail due to: <ul style="list-style-type: none"> <li>• High short current not protected by proper fuses.</li> <li>• High voltage spikes not protected by proper external varistors.</li> <li>• Frequent starting at max. conditions or fault conditions.</li> </ul>
OVERTEMPERATURE	Heatsink overtemperature. Trips the starter when the heatsink temperature rises above 85°C. Improve cooling. Check the motor stiring is not too frequent.
EXTERNAL FAULT	Trips the starter when a N.O. contact between terminal A2 and C1 closes for over two seconds. Check contact position and cause of closure.

---

<b>Fault</b>	<b>Description</b>
WRONG PARAMETERS	Parameters were not transferred from RAM to EEPROM. This may happen after replacing the EEPROM with a new version program. Press “Reset” key, then “Mode” and down arrow keys simultaneously and save new default parameters by pressing “Store” and “Mode” keys simultaneously. (If “Fault” LED is illuminated, press “Reset” key after storing parameters.)

---

*NOTE: When operating in generator mode, shorted SCR and wrong connection faults are not active.*

*a p p e n d i x* **A**

---

**Technical Data/Specifications**

This page intentionally left blank.

# RVS-DX Technical Data/Specifications

## General Information:

Supply Voltage	Line to Line 220-600V (to be specified) +10%, -15%
Frequency	45-65Hz (fixed or variable source)
Control Supply	110-120V +10%, -15%
Control Inputs & Outputs	110-120V
Load	Three phase, three wire, squirrel cage induction motors

## Stop Parameters:

Start FLC	Starter's full load current
Motor FLA	Motor's full load amps, 50-100% of starter FLC
Pump Control Curves	6 field selectable curves to prevent over-pressure and water hammer
Pulse Start Duration	A pulse of 80% voltage for an adjustable time of 0.1-1 second, for starting high friction loads
Initial Voltage	10-50% voltage (can be extended to 10-80%)
Current Limit	100-400% of motor FLA (can be extended to 100-500%)
Acceleration Time	1-30 seconds (can be extended to 1-90 seconds)
Deceleration Time	0-30 seconds (can be extended to 0-90 seconds)
Dual Adjustments	Secondary settings for: Motor FLA, Initial Voltage, Current Limit, Acceleration Time and Deceleration Time
Slow Speed Torque	Torque while the motor is operating at 1/6 speed

## Motor Protection:

Too Many Starts	Maximum allowable number of starts, range: off, 1-10; during time period of 1-60 minutes
Start Inhibit	Time period of 1-60 minutes during which starting is prevented after the "TOO MANY STARTS" fault
Long Start Time (Stall Protection)	Maximum allowable starting time 1-30 seconds (can be extended to 1-250 seconds)
Overcurrent (Shear Pin)	Two operating functions: during starting trips and starter at 850% and during running at 200-850% current, both within 1 cycle.
Electronic Overload ( $I^2T$ )	Adjustable 75-150% of motor FLA, adjustable trip time at 500% current of 1-10 seconds
Undercurrent	Trips when current drops below 20-90% current for time delay of 1-10 seconds
Undervoltage	Trips when main voltage drops below 50-90% for a time delay of 1-10 seconds
Overvoltage	Trips when main voltage increases above 110-125% for a time delay of 1-10 seconds
Phase Loss (Under/Over Frequency)	Trips when one or two phases are missing and when frequency is not between 40 and 65 Hz
Phase Sequence	Trips when phase sequence is wrong
Long Slow Speed Time	Trips if operating at slow speed for more than 1-30 seconds
Wrong Connection	Prevents starting; Trips if motor is not connected or incorrectly connected to the starter
Shorted SCR	Trips is case one or more SCR's have been shorted
Heatsink Overtemperature	Trips when heatsink temperature rises above 85°C
External Fault	Trips when an External Control closes for 2 seconds

**Control:**

Displays	LCD in 4 (field selectable) languages and 4 LEDs
Keypad	6 keys for easy setting
Aux. Contact—immediate or end of accel	1 N.O., 8A, 250 VAC, 2000 VA
Fault Contact	1 N.O., 8A, 250 VAC, 2000 VA

**Temperatures:**

Operating Temperature	-10°C to +40°C
Storage Temperature	-20°C to +70°C

**Standards:**

Dielectric Test	2500 VAC
Degree of Protection	IP20 for frame size A1 IP00 for frame size A2-A5
Pollution Degree	3
EMC	
Emissions	EN 55011                      CISPR 11 Class A
Immunity	EN 55082-2                    ESD 8KV air, IEC 801-2 Fast transients 2KV, IEC 801-4
Safety	EN 600947-1                    Related to safety requirements. UL508C
UL508c listed	on units 8-170 Amps

**Normal Service Conditions**

Altitude	Up to 1000m. For equipment to be used at high altitudes consult Factory.
Humidity	95% at 50°C or 98% at 45°C.

**Starter Consumption Ratings:**

Size A1 & A2	Total starter consumption: 185VA
Size A3-A5	Total starter consumption: 215VA

*a p p e n d i x* ***B***

---

**Dimensional Drawings**

This page intentionally left blank.

# Dimensional Drawings

## Protected Chassis

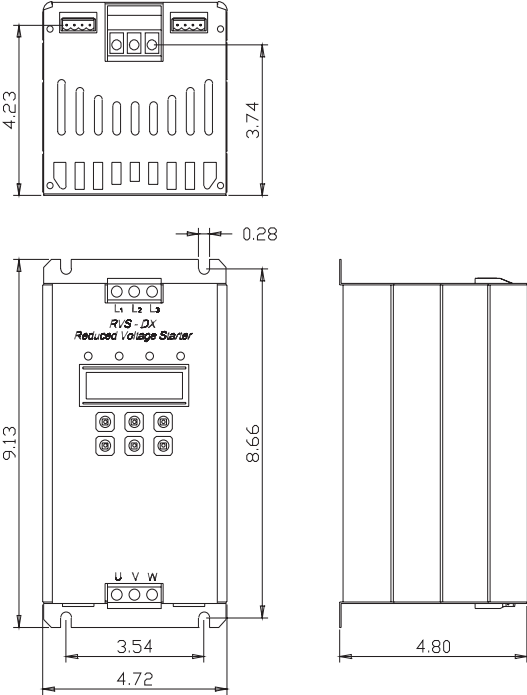

**RVS-DX 8-44A**

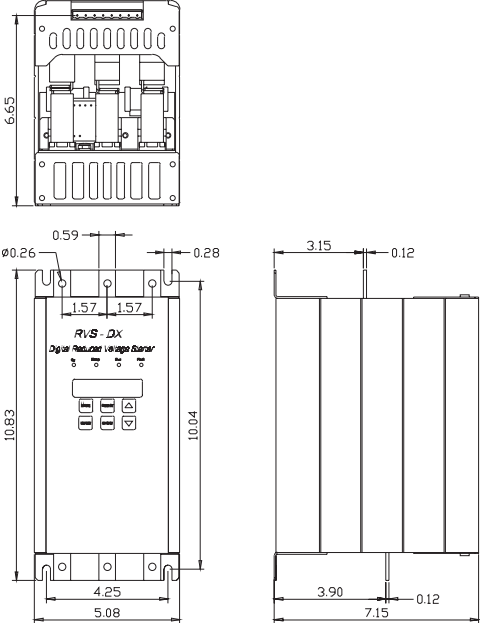

**RVS-DX 58-72**

## Protected Chassis

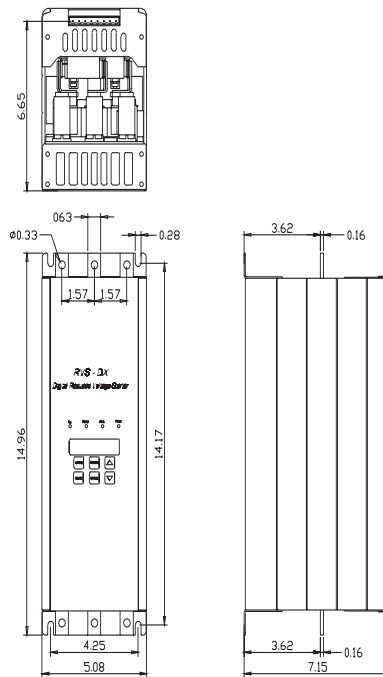

**RVS-DX 85-105A**

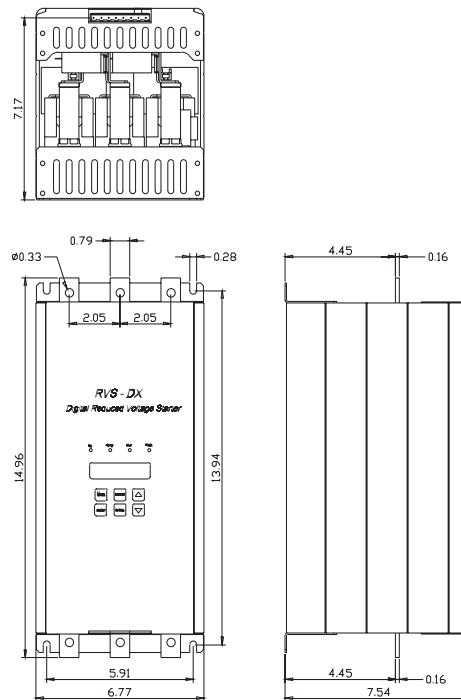

**RVS-DX 145-170A**

## Protected Chassis

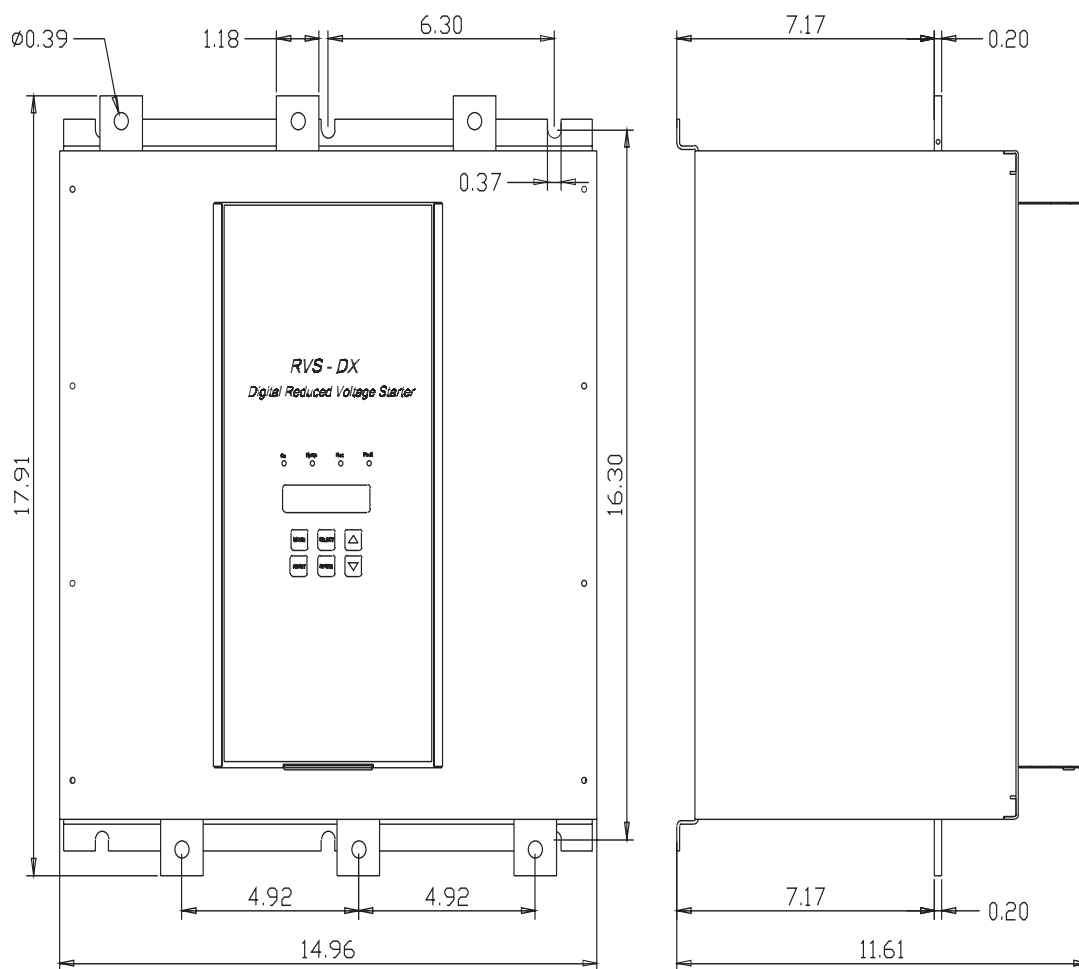

**RVS-DX 210-310A**

*a p p e n d i x* **C**

---

**Fuse Selection Table**

This page intentionally left blank.

## Fuse Selection Table

230 Volt				460 Volt				575 Volt			
RVS-DX	Max. SCR I <sup>2</sup> T Allowed	Fuse Amp Rating	250V Fuse Kit* Part Number	RVS-DX	Max. SCR I <sup>2</sup> T Allowed	Fuse Amp Rating	500V Fuse Kit* Part Number	RVS-DX	Max. SCR I <sup>2</sup> T Allowed	Fuse Amp Rating	700V Fuse Kit* Part Number
8-D	400	40	161-20045	8-D	400	40	161-20055	8-E	400	30	161-20038
17-D	5,00	60	161-20046	17-D	5,00	60	161-20056	17-E	5,000	50	161-20039
31-D	10,000	60	161-20046	31-D	10,000	60	161-20056	31-E	10,00	90	161-20040
44-D	12,000	100	161-20047	44-D	12,000	100	161-20057	44-E	12,000	125	161-20041
58-D	15,000	200	161-20048	58-D	15,000	200	161-20058	58-E	15,000	150	161-20042
72-D	18,000	200	161-20048	72-D	18,000	200	161-20058	72-E	18,000	175	161-20043
85-D	40,000	200	161-20048	85-D	40,000	200	161-20058	85-E	40,000	200	161-20044
105-D	60,000	200	161-20048	105-D	60,000	200	161-20058	105-E	60,000	250	161-20065
145-D	100,000	350	161-20049	145-D	100,000	300	161-20059	145-E	100,000	300	161-20066
170-D	140,000	350	161-20049	170-D	140,000	400	161-20060	170-E	140,000	400	161-20067
210-D	200,000	500	161-20050	210-D	200,000	400	161-20060	210-E	200,000	500	161-20068
310-D	600,000	600	161-20051	310-D	600,000	600	161-20061	310-E	600,000	800	161-20069
390-D	700,00	800	161-20052	390-D	700,000	800	161-20062	390-E	700,000	900	Consult factory

\*Fuse Kit consists of fuses and fuse blocks.