

RVS-DN / Modbus RS-485 Technical Manual



Industrial Controls Group

June 13, 2003

Part Number: 188-10072

© Copyright 2003 Magnetek

Note

Installation, operation, and maintenance should be in strict accordance with the instruction manual, national codes, and good practice. Installation or operation not performed in strict accordance with these instructions will void the manufacturer's warranty.

Warning

RVS-DN must be grounded before connecting serial link wires. Operating without ground can be dangerous and may result in permanent damage to the serial link hardware.

Contents

Chapter 1: Introduction	1-1
Chapter 2: Set Up	
Parameter Settings	2-1
Wiring	2-2
Chapter 3: The Message Format	
Structure of the Message	3-1
Chapter 4: Functions Supported by the RVS-DN	
Memory Organization	4-1
Actual Data	4-1
Setpoints	4-2
Discrete Commands	4-5
Hardwired Control Inputs	4-5
Chapter 5: Error Codes and Troubleshooting	
Exception Response	5-1
RVS-DN Faults	5-2
Resetting after a Fault	5-2
Chapter 6: Examples	
Message and Response Examples	6-1

This technical manual summarizes the set up and Modbus RTU protocol to and from the RVS-DN. The Modbus RS-485 Serial Communications port is an option that must be ordered with the RVS-DN soft starter.

The Modbus RTU protocol requires that the controller communicate using a master-slave technique, in which only one device (the master) can initiate transactions. The other devices (the slaves) respond by supplying the requested data to the master, or by taking the action requested. The RVS-DN soft starter must act in the slave mode.

A complete understanding of the RVS-DN soft starter is required before attempting serial communication operation. A full discussion of programming and operation of the RVS-DN soft starter is available in the RVS-DN Technical Manual (part # 188-10036).

RVS-DN / Modbus RTU Specifications

- RS-485 Hardware
- Asynchronous serial link
- Half Duplex
- Modbus RTU Format
 - Binary
 - Each character includes 11 bits
 - 1 start bit
 - 8 data bits, least significant to be sent first
 - 1 parity bit (even, odd, or none)
 - 1 stop bit (if parity is used, 2 stop bits if no parity is used)
 - Cyclical Redundancy Check (CRC), 16 bits
- Baud Rate: 1200, 2400, 4800, or 9600 bits per second
- Response Time of the RVS-DN
 - Normally, 4 – 40 msec
 - For a long response, < 200 msec

Notes:

1. *Transmitting to the RVS-DN faster than once per second, may slow down the response time.*
2. *After storing setpoints, do not transmit within 1 second to the same RVS-DN.*
3. *Broadcast commands are NOT supported.*
4. *Connection of 120 Ohm resistors on both ends of the serial link is recommended.*
5. *The RVS-DN control power must be cycled after changing the baud rate, parity check, or serial link number (slave address). These parameters can only be set manually (not through the serial link).*

Parameter Settings -

COMM. PARAMETERS

Note: This mode WILL NOT APPEAR if dip switch No. 1 is set to ON.

If a change to a communication parameter is required, press the “Select” key until the desired parameter is reached. Then use the up arrow and down arrow keys to modify the parameter setting.

DRIVE NUMBER
0

Drive Number - 0-999

BAUD RATE
9600

Baud Rate - 1200-9600 bps

PARITY CHECK
EVEN

Parity Check - Even, Odd, No

SERIAL LINK NO.
248 (OFF)

Serial Link Number - 1-248 (up to 32 starters on one twisted pair)

STORE ENABLE
COMM. PARAMETERS

When this message is displayed on LCD, press the “Store” key to save any adjusted parameters.

When the parameters were correctly stored the LCD will display the “ DATA SAVED OK ” message. If the parameters were not stored, the LCD will display “ STORAGE ERROR ”.

Note:

The RVS-DN control power must be cycled after saving any changes to the COMM PARAMETERS, before the master device will recognize the new COMM PARAMETER settings.

Wiring -

Wiring of the serial link requires a twisted shielded pair (Belden 9841 is recommended). Locate terminals 22, 23, and 24 on the RVS-DN. 120 Ohm resistors should be used on each end of the serial link. Terminals 4 and 5 must be tied to control power, to operate in communications mode.

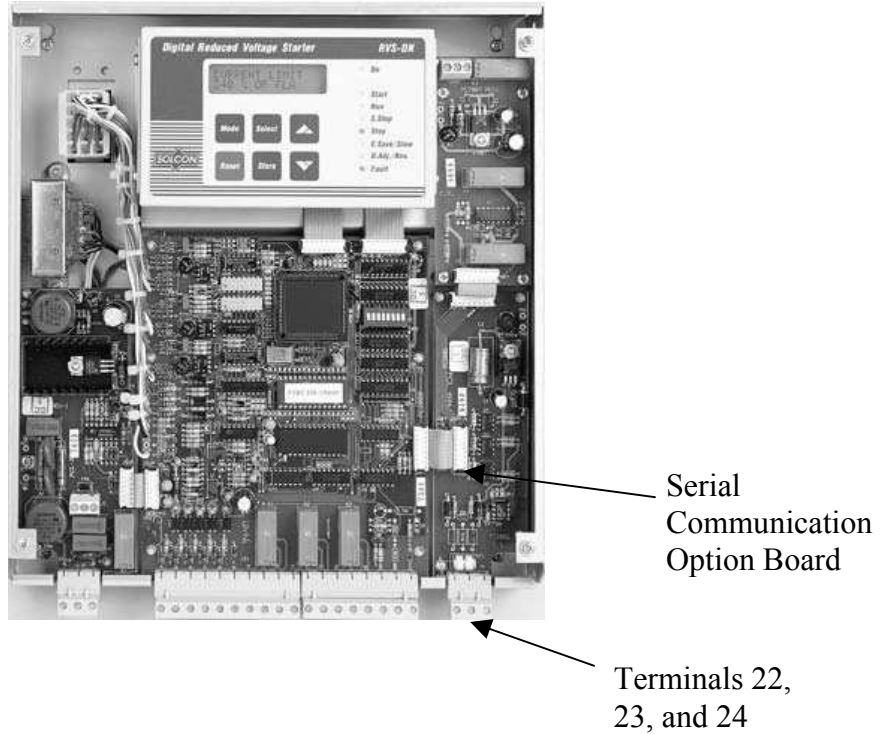

Functions of RVS-DN Serial Communication Terminals

Terminal	Function
22	Shield connection terminal
23	S/R (-) RS-485 input/output (-)
24	S/R (+) RS-485 input/output (+)

Note

Avoid sources of electrical interference capable of inducing noise into the cable. Communication and signal wiring should be kept separate from power wiring. If communication or signal wiring must cross power wiring, it must cross at a right angle.

Wiring –

Operation via Serial Communication link with a Local / Remote selector switch:

Remote operation – Communication link

Local operation – Start / Soft Stop switch

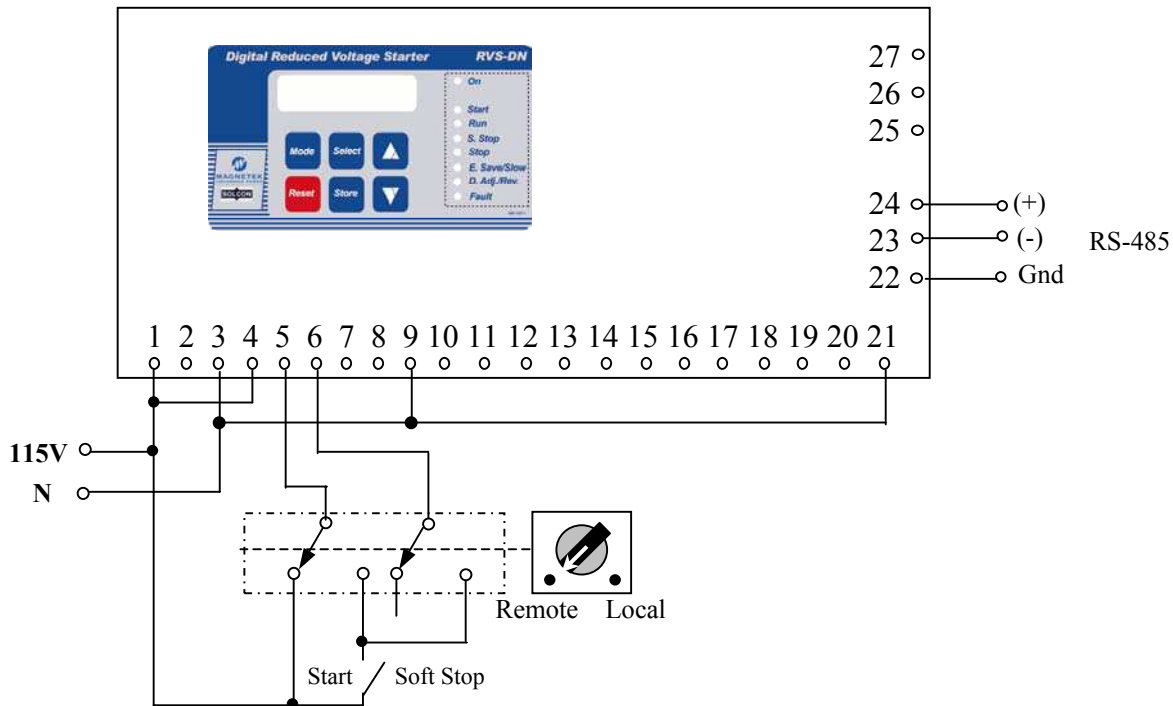

Wiring Instructions

1. Connect communication line (twisted shielded pair) to terminals 22, 23, and 24.
2. Connect terminal 1 to control power and terminal 3 to neutral of control power.
3. Connect terminal 4 to control power.
4. Connect terminal 9 and 21 to neutral. Terminal 21 must be at ground potential, otherwise left open.
5. During operation via communication link, terminal 5 is connected through the local/remote switch to control power and start/stop commands will be controlled through communication port.
6. During operation in local mode, terminals 5 and 6 are connected to control power through the start/soft stop switch.

Wiring –

Operation via Serial Communication link momentary pushbuttons for start, soft stop, and immediate stop:

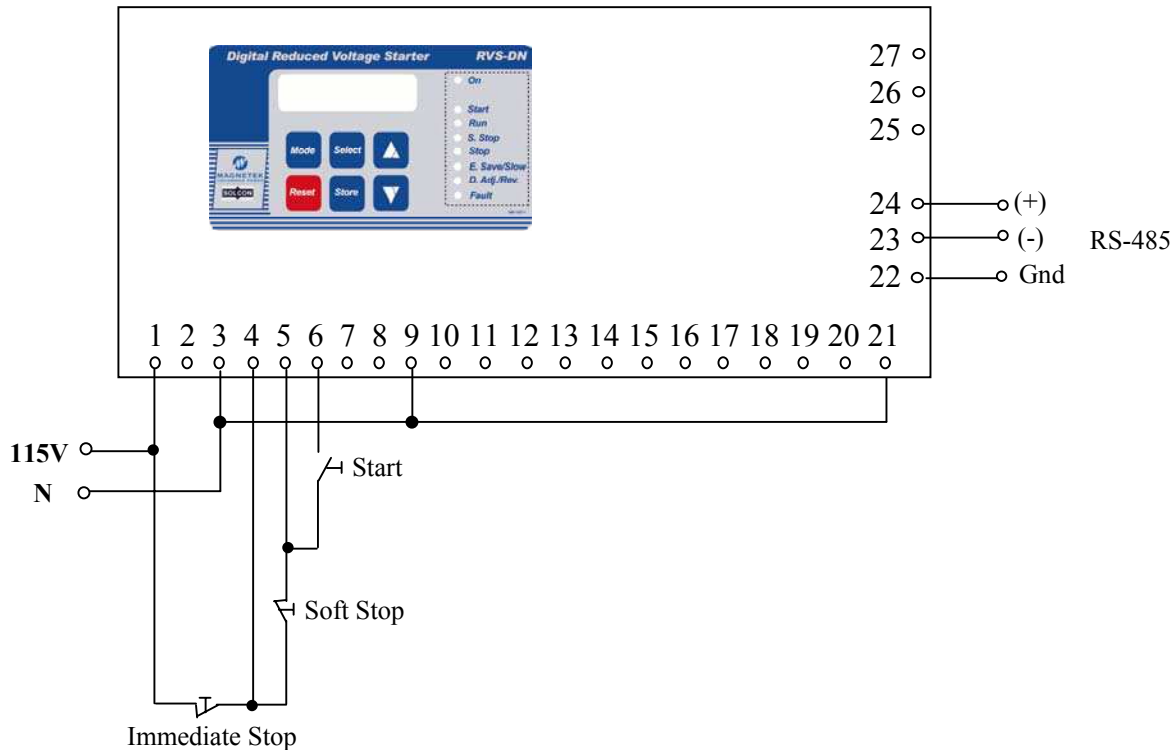

Wiring Instructions

1. Connect communication line (twisted shielded pair) to terminals 22, 23, and 24.
2. Connect terminal 1 to control power and terminal 3 to neutral of control power.
3. Connect terminals 4 and 5 through normally closed pushbuttons to control power.
4. Connect terminal 6 through a normally open pushbutton to control power.
5. Connect terminal 9 and 21 to neutral. Terminal 21 must be at ground potential, otherwise left open.
6. During operation via communication link, terminals 4 and 5 are connected through the pushbuttons to control power, and start, soft stop and immediate stop can be controlled through the communication port.
7. During normal operation, terminals 4 and 5 are connected to control power through the pushbuttons, and soft start may be initiated by pressing the start pushbutton.

Notes:

1. The communication (data retrieval and statistics) is active at all times.
 2. When start/stop control is required via communication port, terminals 4 and 5 must be wired to control power (as indicated in the wiring examples).
-

Structure of the Message -

The Modbus RTU frame has the same structure for both a 'Read' transmission from the master to the slave, and a 'Response' from the slave to the master.

The frame structure is:

<i>"sync"</i>	<i>Silent time of at least 3.5 characters (3.5 * 11 bit times)</i>
<i>byte 1:</i>	<i>Serial Link Number (slave address from 1 to 247)</i>
<i>byte 2:</i>	<i>Function (1,2,3,4,5,6,8,15, & 16 are supported)</i>
<i>byte 3:</i>	<i>Data Bytes (\$XX)</i>
<i>byte n-1:</i>	<i>CRC_low (\$XX)</i>
<i>byte n:</i>	<i>CRC_high (\$XX)</i>
<i>"sync"</i>	<i>Silent time of at least 3.5 characters (3.5 * 11 bit times)</i>

Sync (Silent Interval) -

Modbus RTU messages are "synchronized" by "Silent Intervals" of more than 3.5 character times which separate between transmission frames. Therefore, the entire frame must be transmitted as a continuous stream. A silent interval of more than 3.5 character times during frame transmission will cause the receiving device to ignore the incomplete frame. Next byte will be assumed as the serial link number of the next frame.

Similarly, the frame will be ignored if a second message is transmitted before the 3.5 character times from the end of the previous message, causing the receiving device to consider it as a continuation of the first frame, thus resulting in a CRC error.

Serial Link Number -

The RVS-DN slave number on the serial link can be set from 1 to 247 (default value is 248, which is communication OFF condition). The serial link number is used as the first byte in both read and response messages.

Note

Serial link number of 0, which is normally for broadcast messages, is NOT supported by the RVS-DN.

Function -

The function code defines the required operation. Normally, the function is used as the second byte in both read and response messages. The Functions supported by the RVS-DN are:

Function No.	Modbus Name of Function	Operation in RVS-DN
01	Read Coil Status	Read discrete command status
02	Read Input Status	Read discrete input status
03	Read Holding Registers	Read setpoints
04	Read Input Registers	Read actual data
05	Force Single Coil	Force one discrete command
06	Force Single Register	Write to one setpoint
08	Diagnostic	Loopback Test
15	Force Multiple Coils	Force discrete command
16	Force Multiple Registers	Write to setpoints

Data –

The data field includes information transferred to and from the RVS-DN. The specific data format is changed with the Function. When Word data parameters are transmitted, the high byte is transmitted first, followed by the low byte.

CRC –

The CRC (Cyclic Redundancy Check) consists of two bytes (16 bit), which are used to check the entire frame bytes for accuracy. The CRC is generated in the master device and transmitted as the last two bytes of the frame (low byte is first, followed by the high byte). The slave device generates the CRC bytes again and compares it to the received CRC bytes. If the CRC bytes are not identical, the frame is flushed and no response is transmitted to the master.

Chapter 4

Modbus Functions Supported by the RVS-DN

The RVS-DN memory is organized according to common Modbus addresses as shown below:

RVS-DN Use	Memory Type	Max. Query	Response Parameters
Actual Data	3X References	32 registers	#1-32; addressed 0-31 (0-1F hex)
Setpoints	4X References	84 registers	#1-84, addressed 0-83 (0-53 hex)
Hardwired Control Inputs	1X References	16 inputs	#1-16, addressed 0-15 (0-F hex)
Discrete Serial Commands	0X References	16 coils	#1-16, addressed 0-15 (0-F hex)

Actual Data (3X References) -

Actual Data includes measured values (such as voltage, current and insulation resistance), logic and statistical information. All parameters are word (two bytes) parameters. The protocol supports only reading of these parameters.

The Register # (in hex) is the hexadecimal value of the address of the parameter. The actual parameter address is 1 lower than parameter #. For example the address of parameter #12 is 11 (30011), and the hexadecimal register # is B.

The parameters have the following 3x references:

Register # (in hex)	Function of the Parameter	Bit No.	Description (a '1' indicates)		
0	Logic Status	0-5	Reserved (all zeros)		
		6	Motor stopped		
		7	Motor in soft stop process		
		8	Motor in start process		
		9	Motor is running		
		10	Dual Adjustment is ON		
		11	Motor is running with energy Save ON		
		12	Motor is running slow speed forward		
		13	Motor is running slow speed reverse		
		14	Insulation alarm		
		15	Reserved (all zeros)		
		1	Current		As % of FLA
		2	Voltage		Line voltage (in volts)
		3	Phase Sequence		1=Correct; 0=Incorrect phase sequence
		4	Hardwired Inputs	0	Stop input
1	Soft stop input				
2	Start input				
3	E.Save/Reverse/Reset (programmable) input				
4	D.Adj./Slow Speed/Reset (programmable) input				
5	Reserved				
6	Reserved				
7	External Fault				
		8-15	Reserved (all zeros)		

Register # (in hex)	Function of the Parameter	Bit No.	Description (a '1' indicates)
5	Dip Switch Settings	0	DS1 OFF – Parameters Minimized
		1	DS2 OFF – Tach feedback disabled
		2	DS3 OFF – Mains enabled (generator disabled)
		3	DS4 OFF – RESERVED (always off)
		4	DS5 OFF – Language Selection
		5	DS6 OFF – Language Selection
		6	DS7 OFF – Std. Parameter Range (extended off)
		7	DS8 OFF – Parameters Unlocked
6	Insulation Resistance		Motor insulation (Kohms)
7,8...F	RESERVED		
10	Status at Supply Loss		Logic Status at control power supply loss
11	Total Run Time		Total running time (in hours)
12	Total Starts		Total number of starts
13	Last Start Period		Duration of last start (in seconds)
14	Last Start Peak Current		Peak current during last starting period
15	Time to Start		Time delay after too many starts trip (in seconds)
16	Total Trips		Total number of trips
17	Last Trip Number		# of last trip (see fault codes in Chapter 5)
18	Previous Trip Current		Current at time of last trip (amps)
19,1A...1F	RESERVED		

Setpoints (4X References) –

These are the parameters that can be set manually and which determine RVS-DN mode of operation and protection levels. All parameters are word (two bytes) parameters.

The protocol supports both reading and modifying most of these parameters.

CAUTION

Parameters must be carefully set, the motor and RVS-DN starter
may be damaged by incorrect settings!

The Register # (in hex) is the hexadecimal value of the address of the parameter. The actual parameter address is 1 lower than parameter #. For example the address of parameter #28 is 27 (40027), and the hexadecimal register # is 1B.

The parameters have the following 4x references:

Register # (in hex)	Parameter	Range	Default
Main Parameters			
0	RVS-DN FLC	8 to 2700	
1	Motor FLA	4 to 2700	<i>Matches RVS-DN FLC</i>
3,4...7	RESERVED		
8	Under Current Trip	0 to 90 (% of FLA)	0
9	Under Current Delay	1 to 40 (seconds)	10
A	O/C Shear Pin	200 to 850 (% of FLA)	400
B	Overload Trip	75 to 150 (% of FLA)	115

Register # (in hex)	Parameter	Range	Default
C	Overload Delay	1 to 10 (seconds)	4
D	Under Voltage Trip	120 to 600 (volts)	396
E	Under Voltage Delay	1 to 10 (seconds)	5
F	Over Voltage Trip	150 to 750 (volts)	528
10	Over Voltage Delay	1 to 10 (seconds)	2
11,12...17	RESERVED		
Start Parameters			
18	Soft Start Curve	0 to 9 (4-9 are for tach only)	0 (standard)
19	Pulse Time	0 to 10 (tenth of second)	0 (off)
1A	Initial Voltage	10 to 80 (% of voltage)	30
1B	Current Limit	100 to 500 (% of FLA)	400
1C	Acceleration Time	1 to 90 (seconds)	10
1D	Max Start Time	1 to 250 (seconds)	30
1E	Number of Starts	1 to 10 (11=off)	10
1F	Starts Period	1 to 60 (minutes)	30
20	Start Inhibit Time	1 to 60 (minutes)	15
21	Run Contact Delay	0 to 40 (seconds)	5
22,23...27	RESERVED		
Stop Parameters			
28	Soft Stop Curve	0 to 9 (4-9 are tach only)	0 (standard)
29	Deceleration Time	1 to 30 (seconds)	10
2A	Final Torque	0 to 10 (0 = minimum)	0
2B,2C...2F	RESERVED		
Dual Adjust Parameters			
30	DA Initial Voltage	10 to 80 (% of full voltage)	30
31	DA Current Limit	100 to 500 (% of FLA)	400
32	DA Accel. Time	1 to 90 (seconds)	10
33	DA Dec. Time	1 to 30 (seconds)	10
34	DA Motor FLA	5 to 2700 (amps)	<i>matches RVS-DN FLC</i>
35,36,37	RESERVED		
Energy Save & Slow Speed Parameters			
38	Energy Save	0 to 10 (0=minimum)	0
39	Slow Speed Torque	1 to 10 (1=minimum)	8
3A	Max. Slow Spd Time	1 to 250 (seconds)	30
3B,3C...3F	RESERVED		
Fault Parameters			
40	Phase Sequence	0 or 1 (0=off; 1=on)	0
41	Insulation Alarm	1 to 50 (tenth of Mohm = 1 is off and 0.2 to 5Mohm)	1
42	Insulation Trip	1 to 50 (tenth of Mohm = 1 is off and 0.2 to 5 Mohm)	1
43	Auto Reset	0 or 1 (0=off; 1=on)	0
44,45...47			
I/O Programming Parameters			
49	Input (terminal) 7	0,1,2 (0=E.Save, 1=S.Spd, 2=Rst)	0
4A	Input (terminal) 8	0,1,2 (0=D.Adj, 1=Rvrs, 2=Rst)	0
4B	Fault Relay Type	0 or 1 (0=Fault, 1=Fail Safe)	0
4C	Imm. Relay On Delay	0 to 60 (seconds)	0

Register # (in hex)	Parameter	Range	Default
4D	Imm Relay Off Delay	0 to 60 (seconds)	0
4E,4F,50	RESERVED		
Communication Parameters			
51	Drive Number	1 to 999	1
52	Baud Rate	12 to 96 (*100)	96 (9600)
53	Parity Check	0,1,2 (0=Even, 1=Odd, 2=No)	0 (even)
54	Serial Link No.	1 to 247 (248=off)	248 (off)

Notes:

1. When Preset Single Register Function (06) is used to adjust *one* setpoint parameter, the communication program checks that the parameter value is within the allowed limits. If it is not, an Exception Response (Exception code 03) is returned instead of a Normal response. (see Exception Responses in chapter 5).
2. If Preset Multiple Register Function (16) is used to adjust one or multiple setpoint parameters, then even if one or more setpoint parameters are out of range, a normal response will be returned. The RVS-DN program will check later the value of each parameter. If it is beyond the allowed limit, the limit value will be stored instead the transmitted parameter value.
3. It is strongly recommended to preset setpoints only when motor is stopped. The RVS-DN enables, however to preset *one* parameter (using function 06 only) when motor is running at full voltage. When motor is soft starting, soft stopping, or running with energy saving or at slow speed; the RVS-DN ignores "Preset Single Register" or "Force Multiple Register" instructions. A "busy" Exception response is returned by the RVS-DN whenever it's logic condition does not enable presetting.
4. Always wait more than 0.5 Sec. after using Functions 06 or 16 to preset parameter(s) before transmitting again to the same RVS-DN.
5. Communication parameters 51, 52, and 53 (hex) can only be read through serial link. They can only be set (written) manually.
6. It is the user responsibility to read and check all changed setpoint parameters after presetting.

Discrete Commands (Coils 0X References) –

The RVS-DN incorporates 16 "Coils", (bit parameters), from which only 5 are operative. The other 10 are reserved and were incorporated to enable using word (16 bits) type parameters.

The Register # (in hex) is the hexadecimal value of the address of the coil. The actual address is 1 lower than coil #. For example the address of coil #3 is 2 (00002), and the hexadecimal register # is 2.

The coils have the following 0x references:

Register # (in hex)	RVS-DN Operation	Comments
0	Stop	Write '1' (ON) to stop.
1	Soft Stop	Write '1' (ON) to soft stop.
2	Start	Write '1' (ON) to start.
3	Energy Save	Write '1' (ON) to use Energy Save.
4	Dual Adjust	Write '1' (ON) to operate Dual Adjust.
5	Slow Speed	Write '1' (ON) for slow speed. Write '0'(OFF) to start at normal speed.
6	Slow Speed Reverse	Write '1' (ON) for reverse direction. Write '0' (OFF) for forward direction.
7	Reset	Write '1' (ON) to reset.
8,9...F	RESERVED	

Discrete Hardware Inputs (1X References) –

The RVS-DN incorporates 16 Discrete Inputs, (bit parameters), from which only 6 are operative. The other 10 are reserved and were incorporated to enable using word (16 bits) type parameters.

The register # (in hex) is the hexadecimal value of the address of the input. The actual address is 1 lower than input #. For example the address of input #8 is 7 (10007), and the hexadecimal register # is 7.

The inputs have the following 1x references:

Register # (in hex)	RVS-DN Use	Comments
0	Stop (terminal 4)	Open Input (input reads 0) to stop. Close Input (input reads 1) to enable starting/running.
1	Soft Stop (terminal 5)	Open Input (reads 0) to soft stop. Close Input (reads 1) to enable starting/running.
2	Start (terminal 6)	Close Input (input reads 1) to start
3	Terminal 7 *	Close input (1) for On; open (0) for Off.
4	Terminal 8 **	Close input (1) for On; open (0) for Off.
5,6	RESERVED	
7	External Fault (19)	Open input (0) = no fault; close input (1) = fault.
8,9...F	RESERVED	

*Terminal 7 is programmable for energy save, slow speed, or reset.

** Terminal 8 is programmable for dual adjust, slow speed reverse, or reset.

Exception Responses –

When the master sends a query frame to an RVS-DN, one of the following four responses from the RVS-DN is possible:

1. If there is no communication error detected in the query, and no mistake found by the communication program in the RVS-DN, a normal response is returned.
2. If the RVS-DN does not receive the query frame (for example, due to a disconnected serial link cable) then no response is returned. The master will eventually cause a timeout condition.
3. If the RVS-DN receives the query, but a faulty CRC byte and/or Parity bits are detected, then no response is returned. The master will eventually cause a timeout condition.
4. If no communication error is detected in the query, but the RVS-DN communication program finds an error such as illegal Function, data address or data value, or if the RVS-DN is busy, then an Exception response is returned.
The Exception response includes the Exception Code to inform the master about the type of error.

Exception Response Frame

Exception response frame holds a fixed number of 5 bytes. The first one - the Slave Address field is the Serial link number (transmitted in query and identical to RVS-DN Serial Link No.). The second byte - the Function field returns the echo of the transmitted query function, but with the Most Significant Bit set to 1 (adding \$80 to the transmitted function code). The third byte is the Exception Code, indicating the type of error. Last two bytes are the CRC bytes.

Exception Codes supported by the RVS-DN:

Exception Code	Type	Comment
01	Illegal Function	Requested Function is not supported. Functions 1-6, 8, 15, or 16 are supported.
02	Illegal Data Address	Data address is not allowed.
03	Illegal Data Value	Data value is not in the allowed range.
06	RVS-DN Busy	RVS-DN is busy now. Master should transmit the message again later.

RVS-DN Faults –

If the RVS-DN trips due to one of its protection features (example: under voltage trip), the following will occur:

1. The LCD display on the unit will display the fault.
2. The fault LED will illuminate.
3. The fault auxiliary relay will energize.
4. The fault number (see table below) will be available on parameter address 23 (17 hex), Last Trip Number.
5. The RVS-DN will stop the motor.

Fault Number	Fault
01	Over Temperature
02	O/C Shear pin
03	Overload
04	Under Current
05	Under Voltage
06	Over Voltage
07	Phase Loss
08	Phase Sequence
09	Shorted SCR
10	Long Start Time
11	Slow Speed Time
12	Wrong Connection
13	External Fault
14	Wrong Parameters
15	EMI/RFI Fault
16	Too Many Starts
17	Motor Insulation

Resetting after a Fault –

To reset the RVS-DN after it has tripped due to a fault condition, the following must occur:

1. The fault condition must be removed.
2. The start signal must be removed.
3. The fault can be reset from the keypad, on terminal 7 or 8 (see I/O Programming in the RVS-DN Technical manual – Part # 188-10036), or by a Modbus serial communication message.

Example 1 - Actual Data (3X References)

To read actual parameters 2 and 3 (Current and Voltage, addressed as 1 and 2 hex) of the RVS-DN with a serial link number of 18, the host computer should send the following frame:

byte 1: Serial Link No.	(\$18)	
byte 2: Function	(\$04)	
byte 3: Starting Address High	(\$00)	
byte 4: Starting Address Low	(\$01)	
byte 5: No. of Points High	(\$00)	
byte 6: No. of Points Low	(\$02)	
byte 7: CRC_Low	(\$XX)	
byte 8: CRC_High	(\$XX)	

The RVS-DN response, (when Current = 400 % of FLA, and Voltage = 420V) is:

byte 1: Serial Link No.	(\$18)	
byte 2: Function	(\$04)	
byte 3: Byte Count	(\$04)	
byte 4: Data High, parameter 2	(\$01)	(400)
byte 5: Data Low, parameter 2	(\$90)	
byte 6: Data High, parameter 3	(\$01)	(420)
byte 7: Data Low, parameter 3	(\$A4)	
byte 8: CRC_Low	(\$XX)	
byte 9: CRC_High	(\$XX)	

Note: \$XX indicates Hexadecimal byte.

Example 2 – Setpoint Parameters (4X References)

To read stop setpoint parameters 41 through 43 (addressed at 28 to 2A in hex), which is the Soft Stop Curve, Deceleration Time, and Final Torque, of the RVS-DN with a serial link number of 96 (60 hex), the host computer should send the following frame:

byte 1: Serial Link No.	(\$60)	
byte 2: Function	(\$03)	
byte 3: Starting Address High	(\$00)	(40)
byte 4: Starting Address Low	(\$28)	
byte 5: No. of Registers High	(\$00)	
byte 6: No. of Registers Low	(\$03)	
byte 7: CRC_Low	(\$XX)	
byte 8: CRC_High	(\$XX)	

The RVS-DN normal response:

byte 1:	Serial Link No.	(\$60)	
byte 2:	Function	(\$03)	
byte 3:	Byte Count	(\$08)	
byte 4:	Data High	(\$00)	(Soft Stop Curve = 0)
byte 5:	Data Low	(\$00)	
byte 6:	Data High	(\$00)	(Deceleration Time = 10Sec.)
byte 7:	Data Low	(\$10)	
byte 8:	Data High	(\$00)	(Final Torque = 0)
byte 9:	Data Low	(\$00)	
byte 10:	CRC_Low	(\$XX)	
byte 11:	CRC_High	(\$XX)	

Example 3 – Setpoint Parameters (4X References)

To write one setpoint parameter (Under_Voltage_Trip = 300V) to Setpoint Parameter # 14 (addressed as D in hex) of RVS-DN serial link # 5, the host computer should send following frame:

byte 1:	Serial Link No.	(\$05)	
byte 2:	Function	(\$06)	
byte 3:	Starting Address High	(\$00)	
byte 4:	Starting Address Low	(\$0D)	(13)
byte 5:	Preset Data High	(\$01)	(300)
byte 6:	Preset Data Low	(\$2C)	
byte 7:	CRC_Low	(\$XX)	
byte 8:	CRC_High	(\$XX)	

The RVS-DN normal response, is an echo of the query:

byte 1:	Serial Link No.	(\$05)	
byte 2:	Function	(\$06)	
byte 3:	Starting Address High	(\$00)	
byte 4:	Starting Address Low	(\$0D)	
byte 5:	Preset Data High	(\$01)	
byte 6:	Preset Data Low	(\$2C)	
byte 7:	CRC_Low	(\$XX)	
byte 8:	CRC_High	(\$XX)	

Example 4 – Setpoint Parameters (4X References)

To write multiple setpoint parameters (Under_Voltage_Trip = 300V, Under_Voltage_delay = 10Sec., Over_Voltage_Trip = 480V, Over_Voltage_delay = 2Sec.) to Setpoints Parameters # 14-17 (addressed as D-10 in hex) to RVS-DN with the serial link # 128 (80 hex), the host computer should send following frame:

byte 1:	Serial Link No.	(\$80)	
byte 2:	Function	(\$10)	
byte 3:	Starting Address High	(\$00)	
byte 4:	Starting Address Low	(\$0D)	
byte 5:	No. of Registers High	(\$00)	
byte 6:	No. of Registers Low	(\$04)	
byte 7:	Byte Count	(\$08)	
byte 8:	Data High	(\$01)	(300)
byte 9:	Data Low	(\$2C)	
byte 10:	Data High	(\$00)	(10)
byte 11:	Data Low	(\$10)	
byte 12:	Data High	(\$01)	(480)
byte 13:	Data Low	(\$E0)	
byte 14:	Data High	(\$00)	(2)
byte 15:	Data Low	(\$02)	
byte 16:	CRC_Low	(\$XX)	
byte 17:	CRC_High	(\$XX)	

The RVS-DN normal response:

byte 1:	Serial Link No.	(\$80)
byte 2:	Function	(\$10)
byte 3:	Starting Address High	(\$00)
byte 4:	Starting Address Low	(\$0D)
byte 5:	No. of Registers High	(\$00)
byte 6:	No. of Registers Low	(\$04)
byte 7:	CRC_Low	(\$XX)
byte 8:	CRC_High	(\$XX)

Note:

Even if the preset data value is beyond the allowed range for one or more setpoint parameters, then a Normal response will be returned. The RVS-DN program will check later the value of each parameter. If it is outside the allowed limit, the limit value will be stored instead the transmitted parameter value. It is the users responsibility to read and check all setpoint parameters after presetting.

Example 5 - Read Coils (0X References)

To read coils 1..8 (addressed at 1 – 8 hex) status of RVS-DN with serial link # 10 (A hex), the host computer should send following Query frame:

byte 1:	Serial Link No.	(\$0A)
byte 2:	Function	(\$01)
byte 3:	Starting Address High	(\$00)
byte 4:	Starting Address Low	(\$00)
byte 5:	No. of Coils High	(\$00)
byte 6:	No. of Coils Low	(\$08)
byte 7:	CRC_Low	(\$XX)
byte 8:	CRC_High	(\$XX)

The RVS-DN response, when coils 7..0 are Off, Off, Off, On, Off, On, Off, and Off:

byte 1:	Serial Link No.	(\$0A)
byte 2:	Function	(\$01)
byte 3:	Byte Count	(\$01)
byte 4:	Data (coils 7..0)	(\$14)
byte 5:	CRC_Low	(\$XX)
byte 6:	CRC_High	(\$XX)

Example 6 - Force Single Coil (0X References)

To stop a motor controlled by RVS-DN with serial link # 1 (1 hex), the host computer should write "1" to the "STOP COIL" (coil 1 addressed as 0).

Note: For Force Single Coil Function, Force Data of \$0000 forces "0" = Off. Force data of \$FF00 forces "1" = On. The "Query" frame sent by the host:

byte 1:	Serial Link No.	(\$01)
byte 2:	Function	(\$05)
byte 3:	Coil Address High	(\$00)
byte 4:	Coils address Low	(\$00)
byte 5:	Force Data High	(\$FF) (force On)
byte 6:	Force Data Low	(\$00)
byte 7:	CRC_Low	(\$XX)
byte 8:	CRC_High	(\$XX)

The normal (if no exception) response:

byte 1:	Serial Link No.	(\$01)
byte 2:	Function	(\$05)
byte 3:	Coil Address High	(\$00)
byte 4:	Coils address Low	(\$01)
byte 5:	Force Data High	(\$FF)
byte 6:	Force Data Low	(\$00)
byte 7:	CRC_Low	(\$XX)
byte 8:	CRC_High	(\$XX)

Notes:

1. The following "discrete" commands have an identical format: Stop, Soft Stop, Start & Reset. For these commands, writing "Off" to coil is meaningless. For example, when the RVS-DN is in Stop condition, (Coil # 1, addressed as 0 = 1 On), while forcing the Stop Coil #1 to Off will have no effect. However, forcing the Start Coil (#3) to On will set the Start Coil and reset the Stop Coil.
2. For Energy Save, Dual Adjust, Slow Speed & Slow Speed Reverse, writing On will turn On the option, while writing "Off" will turn it Off .

Example 7 - Force Multiple coils (0X References)

The motor that is controlled by RVS-DN with serial link # 32 (20 hex) is stopped, and Energy Save, Dual Adjust, Slow Speed and Reverse are set to off.

To start the motor using the Dual Adjust parameters and enabling Energy Save feature (after end of starting), the host computer should write "1" to the Start , Energy Save and Dual Adjust Coils no. 3-5 (addressed as 2-4 hex).

The "Query" frame sent by the host:

byte 1:	Serial Link No.	(\$20)
byte 2:	Function	(\$0F)
byte 3:	Coil Address High	(\$00)
byte 4:	Coils address Low	(\$02)
byte 5:	No. of Coils High	(\$00)
byte 6:	No. of coils Low	(\$03)
byte 7:	Byte Count	(\$01)
byte 8:	Force Data High	(\$00)
byte 9:	Force Data Low	(\$07)
byte 10:	CRC_Low	(\$XX)
byte 11:	CRC_High	(\$XX)

The normal (if no exception) response is the echo of the Query:

byte 1:	Serial Link No.	(\$20)
byte 2:	Function	(\$0F)
byte 3:	Coil Address High	(\$00)
byte 4:	Coils address Low	(\$02)
byte 5:	No. of Coils High	(\$00)
byte 6:	No. of coils Low	(\$03)
byte 7:	CRC_Low	(\$XX)
byte 8:	CRC_High	(\$XX)

Example 8 – Discrete Inputs (1X References)

To read RVS-DN with serial link # 12 (C hex) discrete inputs, the host computer should send following Query frame:

byte 1: Serial Link No.	(\$0C)	(12)
byte 2: Function	(\$02)	
byte 3: Starting Address High	(\$00)	
byte 4: Starting Address Low	(\$00)	
byte 5: No. of Points High	(\$00)	
byte 6: No. of points Low	(\$08)	
byte 7: CRC_Low	(\$XX)	
byte 8: CRC_High	(\$XX)	

The RVS-DN response, when only Stop and Soft Stop terminals (Inputs 1&2) are connected:

byte 1: Serial Link No.	(\$0C)	(12)
byte 2: Function	(\$02)	
byte 3: Byte Count	(\$01)	
byte 4: Data (Inputs 7..0)	(\$03)	
byte 5: CRC_Low	(\$XX)	
byte 6: CRC_High	(\$XX)	

Example 9 – Diagnostics

Modbus Function 08, as implemented in the RVS-DN supports only Subfunction \$0000, providing "loopback" (Return Query Data) feature, for checking the Communication Serial Link between the master and the RVS-DN.

To request RVS-DN with serial link # 1 (1 hex) to return Query data, the master should send following Query frame:

byte 1: Serial Link No.	(\$01)
byte 2: Function	(\$08)
byte 3: Subfunction High	(\$00)
byte 4: Subfunction Low	(\$00)
byte 5: Data High	(\$37)
byte 6: Data Low	(\$A5)
byte 7: CRC_Low	(\$XX)
byte 8: CRC_High	(\$XX)

The normal (if no exception) response is the echo of the Query:

byte 1: Serial Link No.	(\$01)
byte 2: Function	(\$08)
byte 3: Subfunction High	(\$00)
byte 4: Subfunction Low	(\$00)
byte 5: Force Data High	(\$37)
byte 6: Force Data Low	(\$A5)
byte 7: CRC_Low	(\$XX)
byte 8: CRC_High	(\$XX)