

TB681

Operating, Maintenance & Parts Manual

TB603 Manually Lever Operated Chain Hoist

1100 POUNDS MAXIMUM CAPACITY (500 kg)

Follow all instructions and warnings for inspecting, maintaining and operating this hoist.

The use of any hoist presents some risk of personal injury or property damage. That risk is greatly increased if proper instructions and warnings are not followed. Before using this hoist, each operator should become thoroughly familiar with all warnings, instructions, and recommendations in this manual. Retain this manual for future reference and use.

Forward this manual to the hoist operator. Failure to operate the equipment as directed in the manual may cause injury.

Should you have any questions regarding this product, please call Coffing Hoists at **(800) 477-5003**.

Before using the hoist, fill in the information below:

Model No. _____

Serial No. _____

Purchase Date _____



COFFING® HOISTS

Country Club Road • P.O. Box 779 •
Wadesboro, North Carolina 28170 USA
Tel: 800.477.5003 • **Fax:** 800.374.6853 • 704.694.6829
www.coffinghoists.com

SAFETY PRECAUTIONS

Each TB603 Manually Operated Lever Hoist is built in accordance with the specifications contained herein and at the time of manufacture complies with our interpretation of applicable sections of *ASME B30.21, *ANSI/ASME HST-3M and the Occupational Safety and Health Act-1970. The safety laws for elevators and for dumbwaiters specify construction details that are not incorporated in Coffing industrial hoists. We recommend the use of equipment that meets state and national safety codes for such use. Coffing Hoists cannot be responsible for applications other than those for which Coffing equipment is recommended.

*Copies of the standards may be obtained from ASME Order Department, 22 Law Drive, PO Box 2300, Fairfield, NJ 07007-2300.

⚠ WARNING

Improper operation of a hoist can create a potentially hazardous situation which, if not avoided, could result in death or serious injury. To avoid such a potentially hazardous situation, the operator shall:

1. **NOT** operate a malfunctioning or unusually performing hoist.
2. **NOT** operate the hoist until you have thoroughly read and understood this Operating, Maintenance and Parts Manual.
3. **NOT** operate a hoist which has been modified without the manufacturer's approval or certification to be in conformity with applicable OSHA regulations.
4. **NOT** lift or pull more than rated load for the hoist.
5. **NOT** use damaged hoist or hoist that is **not** working properly.
6. **NOT** use hoist with twisted, kinked, damaged, or worn load chain.
7. **NOT** operate with any lever extension (cheater bar).
8. **NOT** attempt to "free-chain" the hoist while load is applied.
9. **NOT** use the hoist to lift, support, or transport people.
10. **NOT** lift loads over people and make sure all personnel remain clear of supported load.
11. **NOT** attempt to lengthen the load chain or repair damaged load chain.
12. Protect the hoist's load chain from weld splatter or other damaging contaminants.
13. **NOT** operate hoist when it is restricted from forming a straight line from hook to hook in the direction of loading.
14. **NOT** use load chain as a sling or wrap load chain around load.
15. **NOT** apply the load to the tip of the hook or to the hook latch.
16. **NOT** apply load unless load chain is properly seated in the chain wheel(s) or sprocket(s).
17. **NOT** apply load if bearing prevents equal loading on all load supporting chains.
18. **NOT** operate beyond the limits of the load chain travel.
19. **NOT** leave load supported by the hoist unattended unless specific precautions have been taken.
20. **NOT** allow the chain or hook to be used as an electrical or welding ground.
21. **NOT** allow the chain or hook to be touched by a live welding electrode.
22. **NOT** remove or obscure the warnings on the hoist.
23. **NOT** operate a hoist which has **not** been securely attached to a suitable support.
24. **NOT** operate a hoist unless load slings or other approved single attachments are properly sized and seated in the hook saddle.
25. **NOT** lift loads that are **not** balanced and that the holding action is **not** secure, taking up slack carefully.
26. **NOT** operate a hoist unless all persons are and remain clear of the supported load.
27. Report malfunctions or unusual performances of a hoist, after it has been shut down until repaired.
28. **NOT** operate a hoist on which the safety placards or decals are missing or illegible.
29. Be familiar with operating controls, procedures and warnings.

⚠ WARNING

Improper operation of a hoist can create a potentially hazardous situation which, if not avoided, could result in minor or moderate injury. To avoid such a potentially hazardous situation, the operator shall:

1. Maintain a firm footing or be otherwise secured when operating the hoist.
2. Check brake function by tensioning the hoist prior to each lift or pulling function.
3. Use hook latches. Latches are to retain slings, chains, etc. under slack conditions only.
4. Make sure the hook latches are closed and not supporting any parts of the load.
5. Make sure the load is free to move and will clear all obstructions.
6. Avoid swinging the load or hook.
7. Avoid lever "fly-back" by keeping a firm grip on the lever until operating stroke is completed and the lever is at rest.
8. Inspect the hoist regularly, replace damaged or worn parts, and keep appropriate records of maintenance.
9. Use the hoist manufacturer's recommended parts when repairing the unit.
10. Lubricate load chain per hoist manufacturer's recommendations.
11. **NOT** use the hoist load limiting or warning device to measure load (if so equipped).
12. **NOT** operate except with manual power.
13. **NOT** permit more than one operator to pull on lever at the same time. More than one operator is likely to cause hoist overload.
14. **NOT** allow your attention to be diverted from operating the hoist.
15. **NOT** allow the hoist to be subjected to sharp contact with other hoists, structures, or objects through misuse.
16. **NOT** adjust or repair the hoist unless qualified to perform such adjustments or repairs.

INSTALLATION

1. Read and understand the safety precautions on page 2 of this manual.
2. Estimate the load that is to be lifted or moved and make sure it does not exceed 1100 pounds (500 kg).
3. Make sure that the support to which the upper hook is attached is strong enough to hold several times the weight of the load. Be sure the hoist is solidly held in in the uppermost part of the upper hook, the latch is closed and the latch does not contact the support.
4. Make sure that the hoist is rigged so that the upper and lower hooks will form a straight line when the hoist is operated and the frame is free to swivel and will not come in contact with any object.

OPERATION

Before using the TB603 Lever Hoist, familiarize yourself with main parts (See Figure 1). Always check the hoist for proper operation before use and under no circumstance should you attempt to use a malfunctioning hoist. To reduce the risk of injury, the user must read and understand this manual.

WARNING

- Failure to use as directed herein may cause injury to you or others and could result in property damage.
- DO NOT exceed the 1100 pound (500 kg) capacity of the hoist or 56 pounds (25 kg) handle pull when lifting or pulling.
 - DO NOT use the hoist to lift people or loads over people.
 - DO NOT use a damaged or malfunctioning hoist.
 - DO NOT use if the load chain is twisted, kinked, worn, stretched or damaged.
 - DO NOT use unless the hoist's frame and chain form a straight line between hooks.
 - DO NOT use if the hoist's frame is in contact with any object.
 - DO NOT leave a suspended load or hoist under tension unattended.
 - DO NOT use an extension on the handle. Operate using hand power only.
 - DO NOT apply loads to the tip of the hooks or to the hook latches.
 - DO NOT remove warning labels and tags from the hoist.

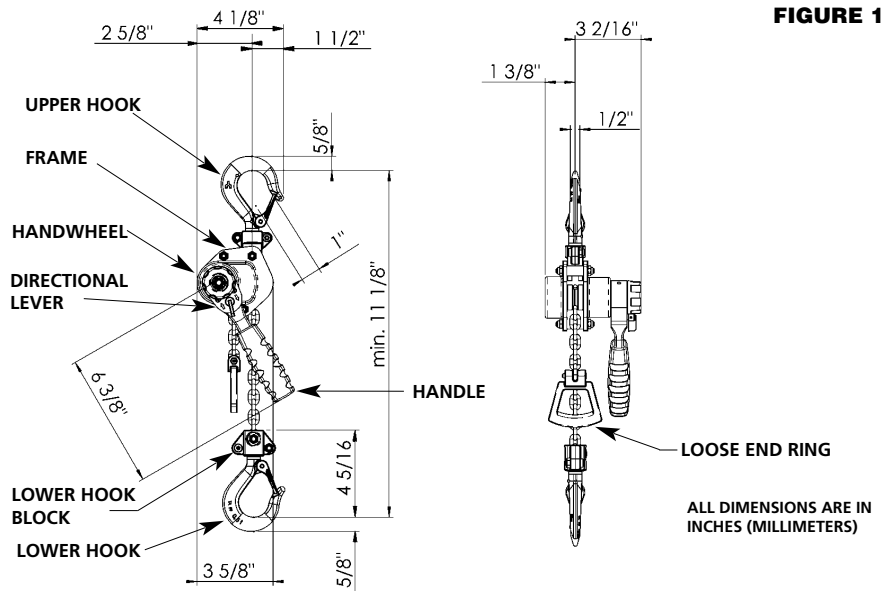

Model Number	Maximum Capacity	Std. Lift	Chain Size	Minimum Distance Between Hooks	Pull on Handle to Lift Max. capacity	Number of 90° Handle Strokes to Lift Load 1 Foot (.3 m)	Net Weight	Shipping Weight
TB603	1100 lbs. (500 kg)	5 ft. (1.5 m)	4 x 12 mm	11 1/8" (282 mm)	56 lbs. (25 kg)	67	6 lbs. (2.7 kg)	7 lbs. (3.2 kg)

COFFING®
HOISTS

FREE CHAINING

In this mode, the load can be pulled through the hoist in either direction by hand for quick attachment to the load. To set the hoist to free chaining mode:

1. With no load on the hoist, move the directional lever to the center (neutral) position.
2. Pull the load chain, in either direction, to its desired length so that the lower hook can be attached to the load. Note that the chain must feed into the hoist freely. If it does not, check for twisted chain. A twisted chain may become damaged by the chain guide rollers or liftwheel and result in chain damage. Pull the chain slowly and be careful: **HANDLE MAY SPIN.**

OPERATING THE LEVER HOIST

The TB603 Lever Hoist can be used in any position as long as it is rigged to pull in a straight line from hook to hook and the frame is free to swivel on the upper hook.

WARNING

If the hoist is not rigged in a straight line hook to hook manner or if the frame is not free to swivel on the upper hook, handle pull may break the frame, bend upper hook and/or break the chain and cause physical injury or loss of load.

To Avoid Injury:

Always rig the hoist in a straight line hook to hook manner and do not allow the frame to touch the load or any object when in use.

When operating in limited spaces, use attachments or slings to make sure the frame is free to swivel on the upper hook and that there are no obstructions that would prevent you from operating the hoist.

1. Suspend or attach the hoist from an adequate support (see **INSTALLATION**).
2. Following the instruction for **FREE CHAINING**, take up the slack chain and attach the lower hook to load to be lifted or moved. Make sure that the load will be applied to the bowl of the lower hook and that it will not be applied to the latch or tip of the hook.
3. To lift or pull load, set the directional lever to (▲) **LOAD** position and slowly pull chain in either direction by hand to ensure the hoist is out of the free chaining mode. **Be careful: HANDLE MAY SPIN.** Then operate the handle up and down to tension the load only enough to check that the brake is engaged and that the attachments to hooks and load are firmly seated. Then repeatedly operate the handle up and down to lift or pull the load. **DO NOT OVERLOAD!** A handle pull of 56 pounds (25 kg) results in applying the maximum capacity of 1100 pounds (500 kg) to the hoist.
4. To lower or loosen the load, move the directional lever to the (▼) **UNLOAD** position and operate the handle up and down repeatedly.

WARNING

With no load on the hoist and when the directional lever is in the (▲) **LOAD** or (▼) **UNLOAD** position, pulling sharply on either end of the chain will cause the handle to spin rapidly.

To Avoid Injury:

Never pull sharply on either end of the chain when the directional lever is in the (▲) **LOAD** or (▼) **UNLOAD** position.

WARNING

If directional lever is forced out of engagement with a load applied, load will be released.

To Avoid Injury:

With a load applied to the hoist, do not force the directional lever into the center (neutral) position.

LOCKED BRAKE

If a hoist under load is suddenly relieved of the load by removing the load from the hoist by some other means, the brake will remain locked. The brake could also lock if the lower hook block is run tightly against the frame. To unlock the brake, move the directional lever to the (▼) **UNLOAD** position and pull sharply on the handle, or reapply the load and operate the hoist in the normal manner.

MAINTENANCE & INSPECTION

The TB603 Lever Hoist normally requires very little maintenance, other than the frequent and periodic inspection listed in the chart on page 6. However, if the hoist is disassembled for inspection, the following should be observed when reassembling (refer to the exploded view and parts lists for relationship and name of parts):

1. The pawl must engage the teeth of the ratchet as shown in Figure 2.
2. The check washer must be positioned on the ratchet hub as shown in Figure 2.
3. When installing the chain, it must be fed through the chain guide rollers with the welds away from the liftwheel, the lower hook must be directly below the upper hook and the loose end ring must be positioned and oriented at the end of the chain as shown in Figure 3
4. A rivet is used to attach the latch to the hook. To remove the latch grind off the head of the rivet. When installing the latch, only peen over the end of the rivet enough to secure it.

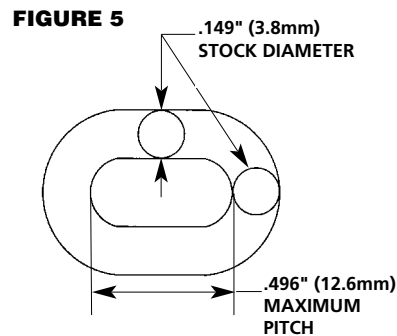
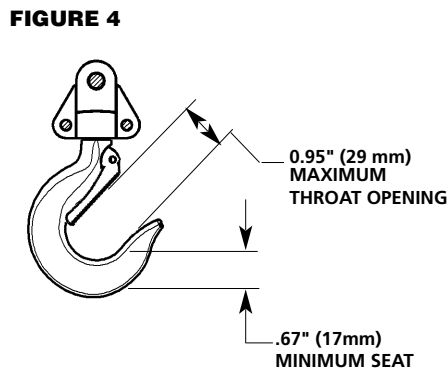
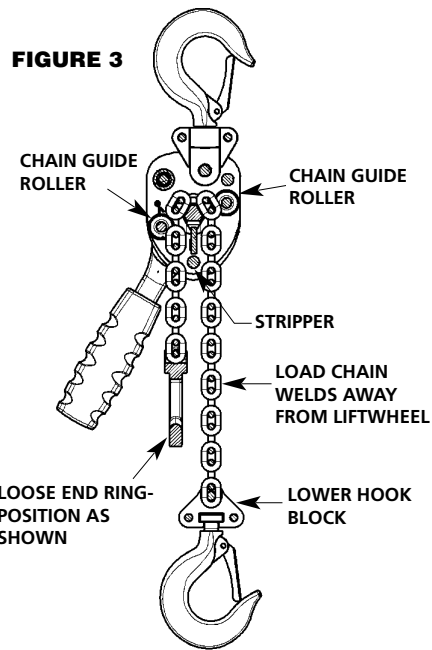
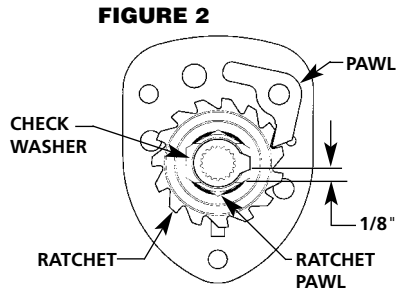

FREQUENT AND PERIODIC INSPECTION CHART

*Daily or before each use.

ITEM	FREQUENCY		WHAT TO CHECK	INSPECTION METHOD	ACCEPTANCE LEVEL
	*DAILY (FREQUENT)	EVERY 6 MONTHS (PERIODIC)			
Labeling and Tags	X	X	Nameplate, capacity label warning labels and free chaining tag	Visually	These items must be legible and securely fastened to the hoist. Replace if necessary.
Operation	X	X	General operation	Lift and Lower a light load.	1.Chain must feed into and out of the hoist freely. 2. Brake must hold the load when handle is released.
	---	X	Overload test	Lift and Lower a 1378# (625 kg) load one foot (300 mm)	1. Pull on handle should be about 73# (33 kg) 2. Brake should operate smoothly while lowering.
	X	X	Directional lever	Movement	Lever must move smoothly.
	X	X	Free chaining	Movement	In free chaining mode, chain should feed into and out of the hoist freely when pulled by hand.
Hook Assemblies	X	X	Hook opening and bowl wear	Measure opening and bowl wear.	See Figure 4.
	X	X	Hook latch	Operation, engagement and damage.	1. Latch must not be damaged. 2. Latch must operate smoothly with sufficient pressure to engage the tip of the hook tightly.
	X	X	Hook deformation	Visually	Hook must not be bent more than 10 degrees from the plane of the unbent hook.
	X	X	Hook chain screw, upper hook pin, hook collars and hook collars hardware	Visually	There must be no damage, corrosion, excessive wear or looseness.
	X	X	Hooks chemical damage, cracks, gouges	Visually	There must be no excessive corrosion, visible cracks or gouges.
Chain	X	X	Lubrication	Visually	Chain should be frequently lubricated using Frisk Bros. Lubriplate 10-R, or equal.
	X	X	Corrosion, pitting, gouges	Visually	There must be no excessive corrosion, pitting or gouges on the chain.
	X	X	Wear and deformation	Measure chain for wear and stretch.	See figure 5.
	X	X	Deformation, twists	Visually	Chain must be free of twists.
Brake Disc	----	X	Wear and contamination	Measure thickness and visually.	Replace brake disc if its thickness is less than 0.094" (2.4 mm) or if the friction surfaces are glazed, oily or contaminated.
Hoist Body	----	X	Side plate and covers	Visually	Frame and covers should not be damaged or corroded.
	X	X	Handle	Visually	Handle must not be bent or corroded. Grip should not be damaged.
	----	X	Stripper	Visually	Stripper must not be bent, corroded or worn.
	X	X	Hardware	Visually	All nuts must not be corroded and must be securely tightened.
	----	X	Pawl and ratchet	Visually	There should be no excessive wear of the ratchet teeth and the tip of the pawl. The pawl spring should not be corroded or stretched.

COFFING®
HOISTS

Figure 6 - TB603 Lever Hoist Exploded View

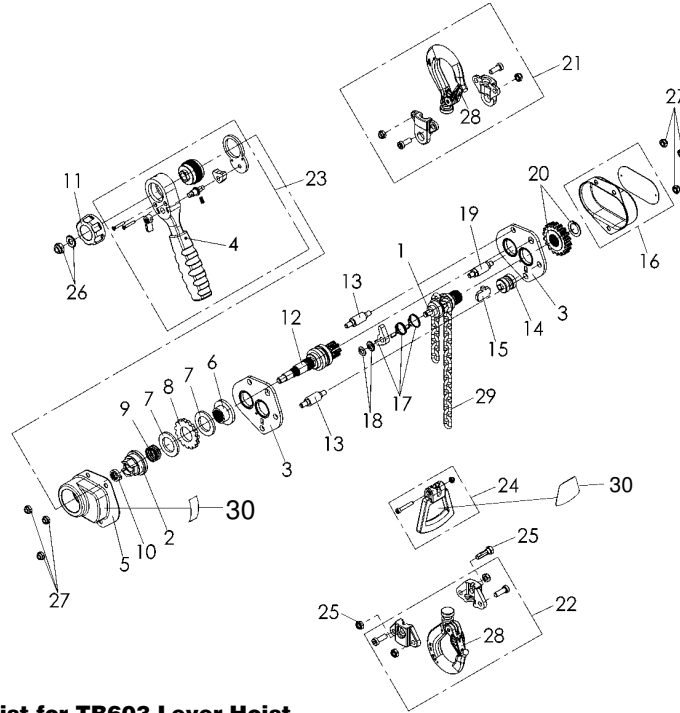

Parts List for TB603 Lever Hoist

Ref. No.	Description	Part No.	Qty	Ref. No.	Description	Part No.	Qty
1	Liftwheel & Shaft	00230329	1	17	Pawl and Springs	00230259	1
2	Ratchet Hub	00230138	1	18	Washer and Snapring	00230348	1
3	Side Plate Assembly	00230328	2	19	Upper Hook Pin	00230336	1
4	Lever Grip	00230153	1	20	Gear Assembly	00230350	1
5	Brake Cover	00230332	1	21	Upper Hook Assembly	00230351	1
6	Friction Hub	00230113	1	22	Lower Hook Assembly	00230342	1
7*	Brake Disc	00210001	2	23	Handle Assembly	00230164	1
8	Ratchet	00230114	1	24	Chain Stop Assembly	00230260	1
9	Brake Spring	00230130	1	25	Chain Screw and Nut	00230352	2
10	Check Washer	00230117	1	26	Brake Nut and Washer	00230262	1
11	Handwheel	00230155	1	27	Cover Nut Kit	00230288	1
12	Drive Shaft	00230330	1	28*	Latch Kit	00400449	2
13	Side Plate Studs	00230331	2	29*	Load Chain (5ft. Lift)	02100009	1
14	Chain Guide Roller	00230335	1	30	Warning Labels, Capacity Label, Nameplate and Drive Screw Kit	00011C	1
15	Stripper	00230340	1				
16	Cover with Nameplate	00230347C	1				

*Indicates parts Coffing Hoists stocks for repairs. All other parts are available on a special order basis-contact Coffing Hoists.

COFFING WARRANTY

Every hoist is thoroughly inspected and performance tested prior to shipment from the factory. If any properly installed, maintained and operated hoist as outlined in the applicable accompanying Coffing Hoists manual develops a performance problem due to defective materials or workmanship as verified by Coffing Hoists, repair or replacement of the hoist will be made to the original purchaser without charge and the hoist will be returned, transportation prepaid. This warranty does not apply where deterioration is caused by normal wear, abuse, improper or inadequate maintenance, eccentric or side loading, overloading, chemical or abrasive actions, excessive heat, unauthorized modifications or repairs, or use of non-Coffing repair parts. **EXCEPT AS STATED HEREIN, COFFING HOISTS MAKES NO OTHER WARRANTIES, EXPRESS OR IMPLIED, INCLUDING WARRANTIES OF MERCHANTABILITY AND FITNESS FOR A PARTICULAR PURPOSE.**

WARNING

Overloading and Improper Use Can Result In Injury

To Avoid Injury:

- Do not exceed working load limit, load rating, or capacity.
- Do not use to lift people or loads over people.
- Use only alloy chain and attachments for overhead lifting.
- Read and follow all instructions.

COFFING® HOISTS

Country Club Road • P.O. Box 779 •
Wadesboro, North Carolina 28170 USA

Tel: 800.477.5003 • **Fax:** 800.374.6853 • 704.694.6829

www.coffinghoists.com