

© 1999 ELECTROMOTIVE SYSTEMS, INC.

All rights reserved. This notice applies to all copyrighted materials included with these products, including, but not limited to, this manual and the software embodied within the product. This manual is intended for the sole use of the person to whom it was provided, and any unauthorized distribution of the manual or dispersal of its contents is strictly forbidden. This manual may not be reproduced in whole or in part by any means whatsoever without the expressed written permission of ELECTROMOTIVE SYSTEMS, INC.



WARNING

- This manual instructs you how to use PulseStar•jr. If you disregard the instructions, information, and/or warranty in the manual, you could be assuming responsibility for damages, costs, or injury incurred by such disregard.
- Do NOT touch any circuit components on the circuit board while the main AC power is on.
- Do NOT change the address settings in the receiver.
- Do NOT make any address changes in the transmitter without first contacting Electromotive Systems.

This page intentionally left blank.

Contents

Welcome!	iii
PulseStar JRT-310	iii
Important System Information	iv

Chapter 1: PulseStar•jr. System Overview

PulseStar•jr. System Overview (JRT-310)	1-3
Introduction	1-3
Theory of Operation	1-3
Active E-Stop Function	1-3
JRT Transmitter	1-4
Introduction	1-4
JRT Components	1-4
Sleep and Time-Out Modes	1-5
Transmitter Sleep Mode	1-5
Receiver Time-Out Mode	1-5

Chapter 2: Installing and Wiring the PulseStar•jr. Receiver

Overview	2-3
Assessing the Receiver Enclosure Environment	2-3
Mounting PulseStar•jr. Receiver Enclosure	2-4
Wiring the PulseStar•jr. Receiver Circuit Board	2-8
Testing The Receiver	2-14
PulseStar•jr.—Receiver	2-14
Changing the Frequency of the Receiver	2-15
The Relay Latching Option	2-16

Chapter 3: Operating the JRT Transmitter

Overview	3-3
Start-up and Operation	3-4
Start-up	3-4
Holding the Transmitter	3-4
Using the Transmitter Pushbuttons	3-5
Shutting Off the Transmitter	3-5
Emergency Stop	3-5
Spare Transmitter Setup	3-6
Replacing the Pushbutton Legends	3-6
Setting the Transmitter Address and Frequency	3-7
Battery Information	3-10

Chapter 4: Troubleshooting PulseStar•jr.

Troubleshooting	4-3
Introduction	4-3

Appendix A: Definitions and Abbreviations

Definitions and Abbreviations	A-3
Definitions	A-3
Commonly Used Abbreviations	A-3

Appendix B: Specifications

Specifications – PulseStar•jr.	B-3
System Specifications	B-3
JRT Transmitter Specifications	B-3
Receiver Specifications	B-4

Appendix C: StarService and Warranty

StarService Policy.....	C-3
On-Call Service.....	C-3
Warranty.....	C-3
Transmitter Loaner & Repair Program	C-3
Receiver Replacement/Repair Program	C-4
Electromotive Systems Limited Warranty.....	C-5

Welcome!

Welcome to the PulseStar•jr. radio remote crane control system. Electromotive Systems has set a whole new standard in radio-remote performance, dependability, and value with this unique new line of modular transmitters and receivers. Without a doubt, PulseStar•jr. is the ultimate solution for having precise, untethered, and safe control of overhead loads.

Using state-of-the-art synthesizer technology and the best circuit board manufacturing designs available, Electromotive Systems has eliminated many of the unreliable and expendable electromechanical components found in traditional radio remote systems.

PulseStar's unique transmitter and receiver design provide a sophisticated, yet easy-to-understand, efficient, and safe radio remote control.

PulseStar JRT-310

The PulseStar•jr model JRT-310 system consists of a receiver and a hand held transmitter for remote control of up to three two-speed crane motions. The system uses PulseStar's synthesizer technology and operates over the 400-470 MHZ band. PulseStar•jr. systems are FCC approved with no site license required.

Two JRT-310 receivers may be used in tandem, one on the bridge and one on the trolley, and thus eliminate the need for control circuit span conductors.

Two JRT-310 receivers can be used to provide Independent/Combined control of two (2) two-speed/trolley hoists from one transmitter. The bottom row of the buttons are used to select "Hoist A and/or Hoist B". In order to alert the operator as to which hoists are active, status light must be mounted on each respective hoist.

JRT-310 Receiver

The JRT-310 Receiver is provided with:

- E-Stop relay
- Start/Mainline relay
- Nine motion relays for discreet output to adjustable frequency drives and/or conductors
- IP65 Weatherproof enclosure

JRT Transmitter

The JRT Three Motion Transmitter is provided with:

- Six two-speed buttons
- Red Mushroom E-Stop button
- On/Off key switch
- Start/Horn button
- Holster with Belt Clip

Important System Information

Before operating PulseStar•jr., read this important system information.

- When not in use, the transmitter should be turned off and stored in a safe place to prevent unauthorized users from operating it.
- If the crane fails to respond properly, stop operation, turn off the transmitter, and report the condition immediately to an appropriate technician or supervisor.
- Wire the receiver circuit board to the crane's ground.
- If you are using an external antenna, mount it on a metal surface with the same ground as the receiver circuit board. Make sure that the antenna is not surrounded by metal or other conductive materials.
- Before working on the transmitter, remove the battery.
- When taking a break or changing the battery, turn the transmitter off with the key switch.
- Make sure that the battery charger is always charging a battery.
- Perform the initial setup or service work only if you have been authorized to do so. Use only Electromotive Systems' spare parts.

chapter **1**

**PulseStar•jr.
System Overview**

This page intentionally left blank.

PulseStar•jr. System Overview (JRT-310)

Introduction

This chapter introduces the basic conceptual information that you should know before installing, wiring, and operating PulseStar•jr.

Theory of Operation

The PulseStar•jr. system consists of a receiver and a transmitter. The transmitter, using PulseStar's synthesizer technology, electronically generates a frequency over which it and the receiver communicate. PulseStar transmitters and receivers operate over the 400–470 MHz frequency range (70-cm band). To ensure safety when the crane is being operated in conjunction with other radio controls, the receiver and transmitter are configured with the same address and frequency. This way, the receiver only accepts commands from the transmitter with the same address and frequency.

NOTE: The PulseStar•jr. transmitters and receivers already have their addresses and frequencies setup before they are shipped. Never change the address in the receiver. The only time you need to change the address and/or frequency inside the transmitter is when you are setting up a spare or replacement transmitter, or when there is interference on a particular frequency. Contact Electromotive Systems before changing any frequencies.

Active E-Stop Function

One of the most important features of the PulseStar•jr. is **Active E-Stop**. The transmitter continuously sends the **Active E-Stop** status signal, followed by the desired crane function. This constant communication between the transmitter and the receiver confirm that the ongoing operations are safe. If the red mushroom E-STOP button is pressed on the transmitter, the **Active E-Stop** relay opens within 45 msec, and crane motion then ceases.

Active E-Stop responds faster than any other PulseStar function. When **Active E-Stop** occurs, the system ignores any other signal it receives. **Active E-Stop** is the only signal that is recognized until the problem is corrected.

Active E-Stop is fail-safe and self-monitoring. If a fault should occur within the **Active E-Stop** circuitry, it will be detected by the decoder, and the system will go into **Active E-Stop** mode.

To restart the system after **Active E-Stop**, pull out the E-STOP button and press the START/HORN button on the transmitter.

JRT Transmitter

Introduction

The JRT transmitter is a hand-held radio control device with pushbuttons to control the crane motions. The JRT can control up to three crane motions. The crane motion pushbuttons have two detents corresponding to two speeds. The START/HORN button is a single-detent button.

JRT Components

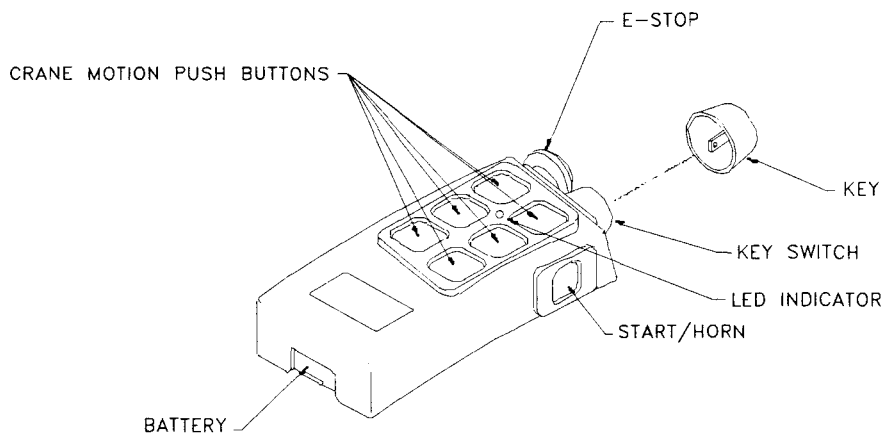

Figure 1.1

START/HORN. The START/HORN button activates the mainline contactor of the crane and sounds a horn (when provided). Once the mainline contactor has been turned on, pressing this button sounds the horn only. When a horn is used, a separate relay is required (not furnished by Electromotive Systems). See Chapter 2 for more information.

E-STOP. Pressing the red E-STOP button will turn off the mainline contactor within 45 msec. The E-STOP button must be pulled out for the transmitter to be operational.

NOTE: The E-STOP button is for emergency situations only. Do NOT use it as an OFF switch. Use the key switch to turn the transmitter on and off.

Crane Motion Pushbuttons. These buttons control the various crane motions and are labeled accordingly.

LED Indicator. As soon as the JRT is turned on, this LED will emit a flashing red light. The transmitter performs a self-test to check the JRT software. If it passes, the LED changes to flashing green and continues flashing green until the transmitter is turned off. This LED changes to a flashing red when the battery is low.

Key Switch. The key switch turns the transmitter on and off. It only works with the key inserted, and can only be removed while in the OFF position.

Sleep and Time-Out Modes

Transmitter Sleep Mode

To prevent accidental operation, the PulseStar•jr. transmitter has a built-in safety feature called **Sleep Mode**. If a transmitter is not used for ten minutes, it turns itself off. While the transmitter is in **Sleep Mode**, none of the buttons will operate. To restart the transmitter, turn the key switch off and then on again. Press the START/HORN button.

Receiver Time-Out Mode

Another PulseStar jr. safety feature is the receiver **Time-Out**. If the receiver detects interference or a loss of signal (including when the transmitter goes into **Sleep Mode**), it will begin the **Time-Out** process.

As soon as the receiver detects a loss of signal or interference, the receiver starts a 45msec. **Time-Out Waiting Period**. Once that expires and the receiver still has not detected a valid signal, the receiver blocks all the crane motion commands to avoid any accidental crane movement. The **Active E-Stop** relay remains closed and the mainline contactor is still active. The receiver then begins a ten-minute timer. If the receiver does not detect a valid signal within that period, it goes into **Active E-Stop**, shutting off power to the mainline contactor.

The receiver time-out waiting period can be eliminated, in which case, the E-STOP relay will open immediately upon loss of signal. (This option must be specified when ordering and configured by Electromotive Systems.)

c h a p t e r **2**

**Installing and Wiring the
PulseStar•jr. Receiver**

This page intentionally left blank.

Overview

This chapter tells you how to install and wire the PulseStar•jr. receiver. It also contains start-up test procedures so you can ensure that the transmitter(s) and receiver are working properly before you actually use them to control the overhead crane.



WARNING

Only authorized personnel are permitted to perform the initial setup or service work. Use only Electromotive Systems' spare parts.

Assessing the Receiver Enclosure Environment

When you choose a location for the receiver enclosure, consider the following guidelines.

1. The Receiver can be operated on the following power supplies:
 - 12-24V, DC (+/-50%)
 - 50V (+/- 20%), AC, Single Phase
 - 110V (+/-20%), AC, Single Phase
 - 240V (+/-20%), AC, Single Phase
2. Ensure that the receiver enclosure will be protected or isolated from:
 - Ambient temperatures outside the range of -22°F to 167°F (-30°C to +75°C) (Consult Electromotive Systems if you must exceed this temperature range).
 - Corrosive gases or liquids.
3. As much as possible, ensure that the receiver is not surrounded by metal or other conductive materials that could prevent the internal antenna from receiving the transmitter signal. If you are using an external antenna, ensure that it is not surrounded by metal or other conductive materials.

Before you prepare to mount the receiver, locate the nameplates on the transmitter and receiver. **The serial number is important if you ever need to call Electromotive Systems for service.** When you mount the receiver, ensure that the nameplate is visible so that you can easily read the serial number.

Mounting PulseStar•jr. Receiver Enclosure

1. Determine the position of the receiver enclosure. Orient the enclosure so that the plug holes are parallel to and facing the floor or the building walls.

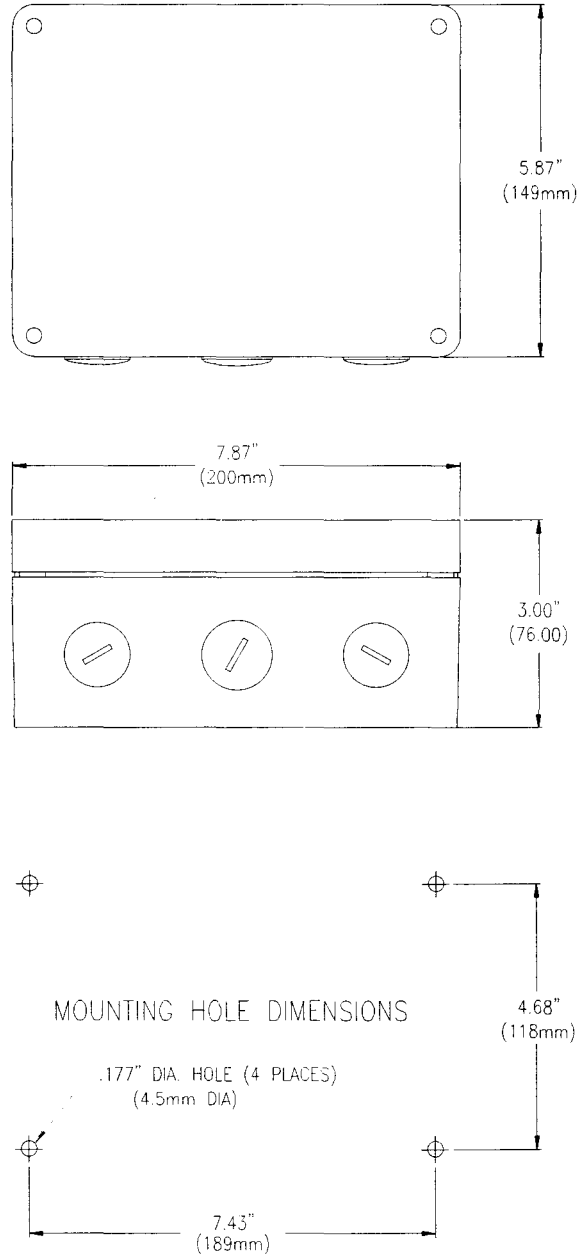

Figure 2.1: Receiver Enclosure

2. Remove the four screws holding the face of the enclosure.

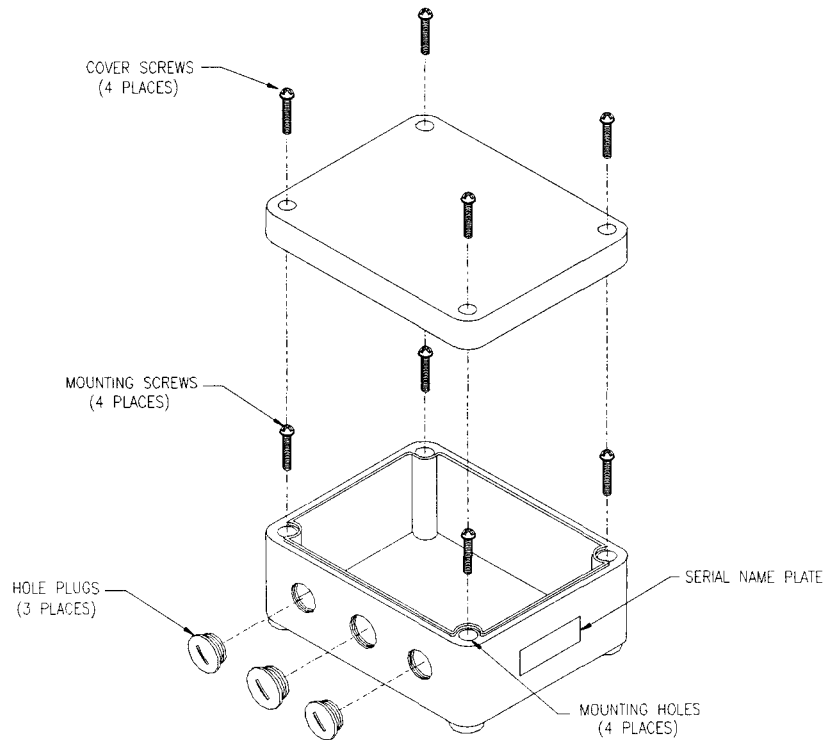

Figure 2.2

3. Drill holes 4.5 mm in diameter (.177 in.) into the mounting surface. The depth of the hole depends on the type of screw you are using to mount the receiver enclosure.
4. Insert the screws through each of the four mounting holes then tighten the four mounting screws to the mounting surface.
5. Determine the sizes and connection locations for the components that need to be wired.
6. Use a screwdriver to remove any of the three hole plugs you are going to use for control or power wires.

7. Lay out the wire runs. At a minimum, use #18 AWG wire for control wiring.

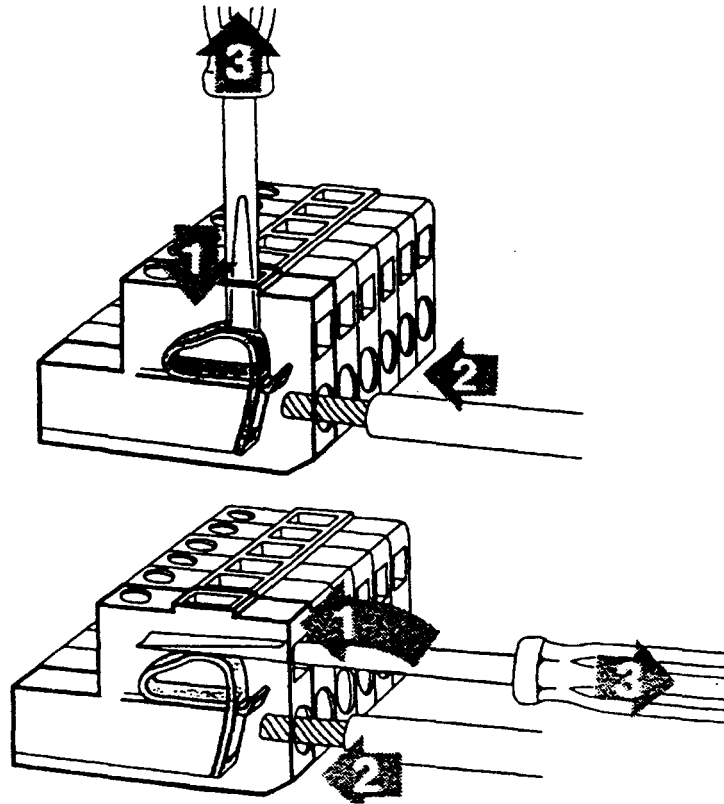

Figure 2.3: Connecting Block of the Receiver with Screwless Terminals

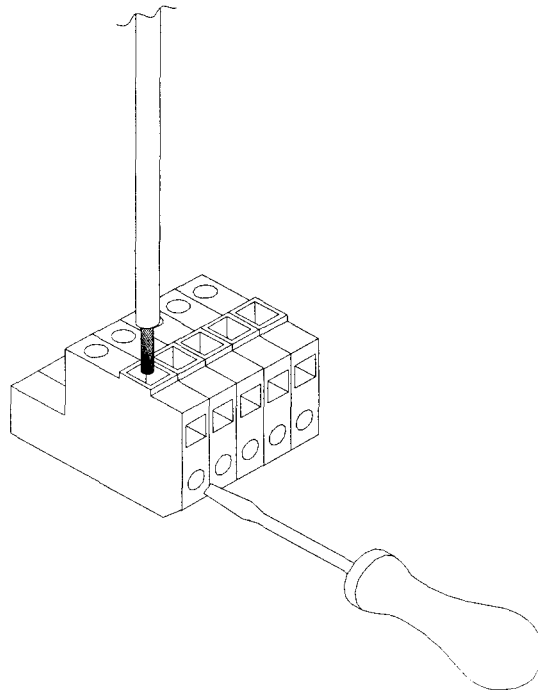

Figure 2.4: Connecting Block of the Receiver with Screw Terminals

Screwless Terminals

To insert wire:

1. Use a standard screwdriver and insert the blade into either the top or side slot of connector and apply pressure to the retention spring as illustrated above.
2. While maintaining pressure on the retention spring insert wire into the wire orifice.
3. Once the wire is inserted into the orifice, remove pressure from the retention spring and remove the screwdriver.

To remove wire:

1. Use a standard screwdriver and insert the blade into either the top or side slot of connector and apply pressure to the retention spring as illustrated above.
2. While maintaining pressure on the retention spring remove wire from the wire orifice.
3. Once the wire is removed from the orifice, remove pressure from the retention spring and remove the screwdriver.

Screw Terminals

To insert wire; loosen screw, insert wire, tighten screw.

To remove wire; loosen screw and remove wire.

Wiring the PulseStar•jr. Receiver Circuit Board

NOTE: Figures 2.5 and 2.6: PulseStar•jr. Receiver Circuit Board show how to wire the receiver board for a two-speed application. For single-speed applications, wire only the FORWARD and REVERSE terminals for each motion.

Three Motion/Two Speed Application

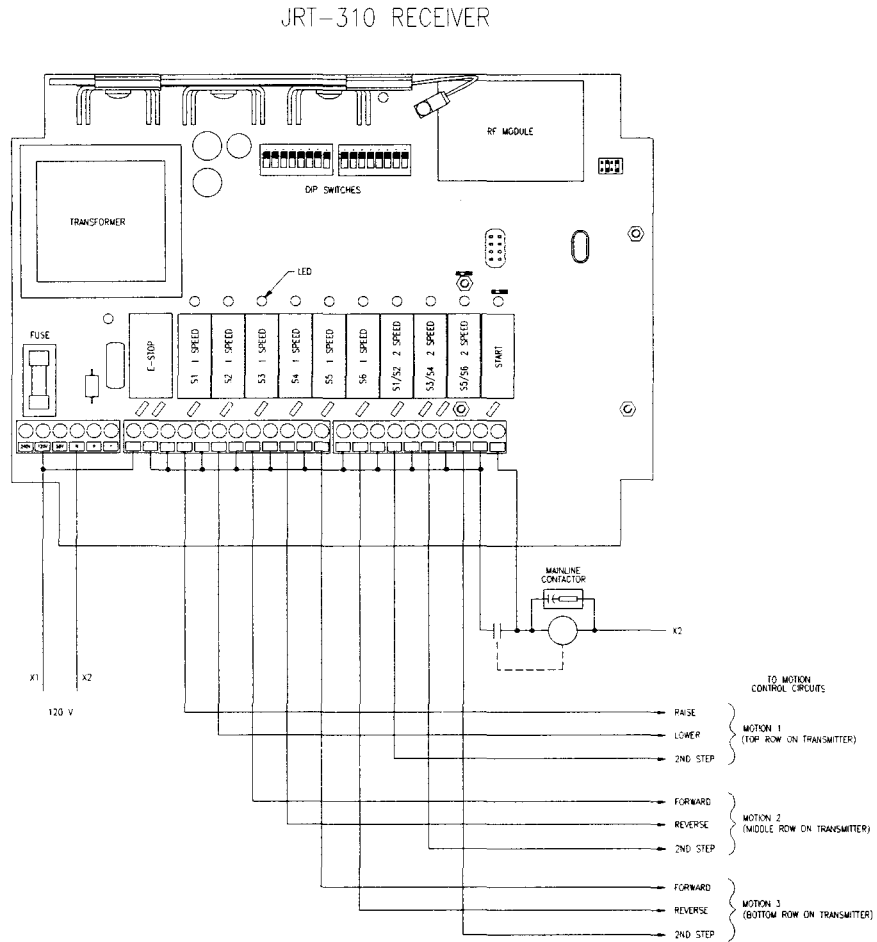

Figure 2.5: PulseStar•jr. Receiver Circuit Board

Two Motion Two Speed Application with A/B Select

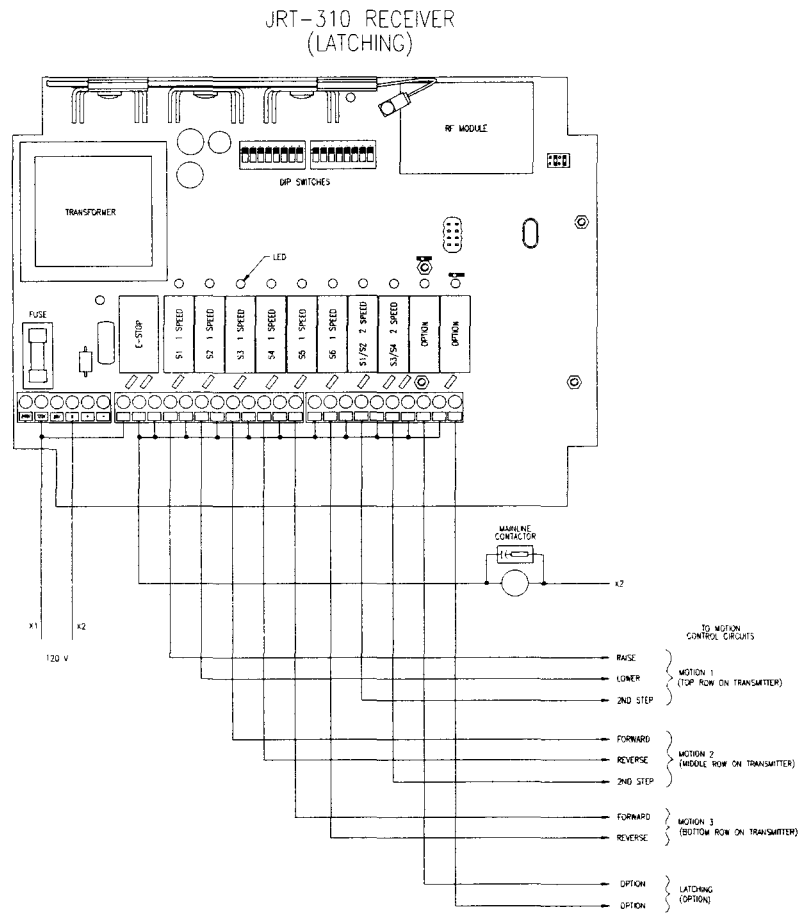

Figure 2.6: PulseStar jr. Receiver Circuit Board for A/B Select

NOTE: The above arrangement requires redefining the standard relay outputs and must be specially configured by Electromotive Systems

1. Refer to the information below to determine the appropriate power input blocks to use.
 - 12–24VDC—use the 6-point terminal block
 - 50VAC—use the 6-point terminal block
 - 110VAC—use the 6-point terminal block
 - 240VAC—use the 6-point terminal block
2. Run the power and control wires through the plug holes of the receiver enclosure.

NOTE: Ensure that the receiver signal wires and the high voltage power wires cross at 90° angles. Also do not combine high voltage power and control wires in the same cable run.
3. Connect incoming power to the 6 point terminal block using either the top or bottom configuration of Figure 2.8 per customer requirement.

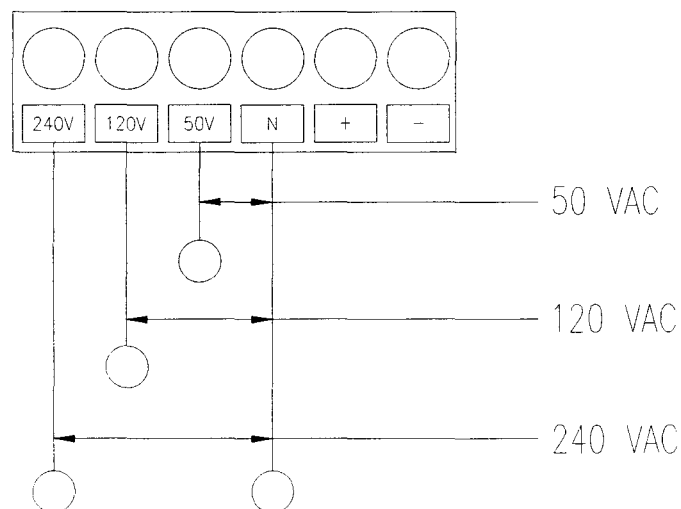
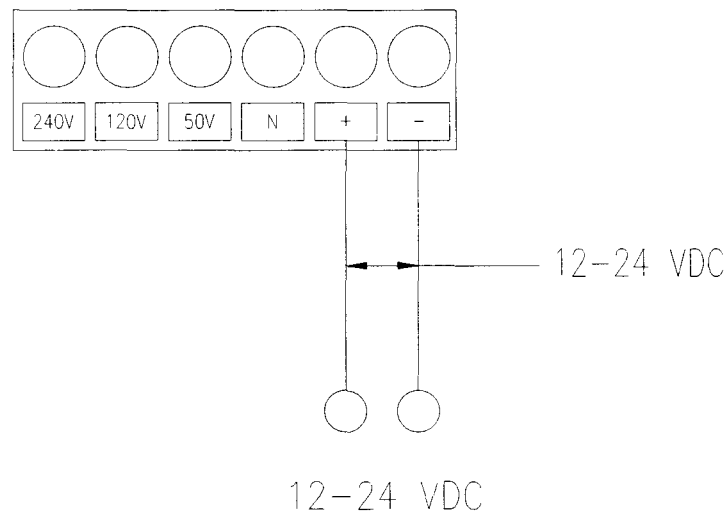

Figure 2.8

- If you are connecting the PulseStar•jr. receiver to a horn, refer to Figure 2.6: PulseStar•jr. Receiver Circuit Board on the previous page and then refer to Figure 2.9.

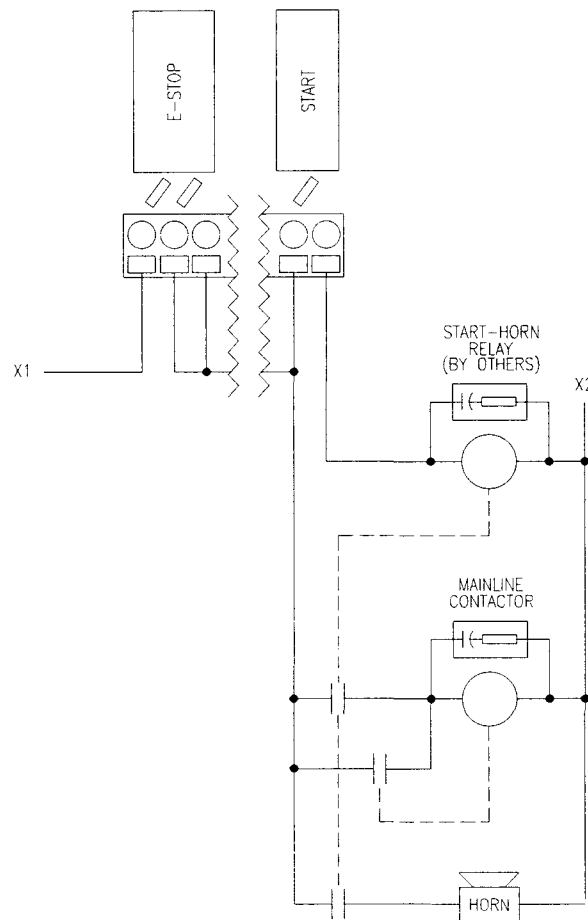

Figure 2.9

- Connect the output wires to the terminal blocks as shown in Figures 2.5, 2.6, 2.7 or 2.9 which ever is appropriate for your application PulseStar•jr. Receiver Circuit Board.
- Snap the terminal blocks to the terminals on the receiver circuit board.
- Install R-C-type surge absorbers (not MOV-type) across the coils of any contactors installed in the control enclosure.
- Reinsert the cover of the receiver enclosure and tighten the four screws.

Connecting an External Antenna

In some cases, such as when the receiver is inside a panel enclosure, you may need to connect an external antenna to the antenna plug on the jr. receiver circuit board instead of using the internal antenna. Mount the antenna on a metal surface with the same ground as the receiver circuit board. As much as possible, ensure that the antenna is not surrounded by metal or other conductive materials. For best reception, the antenna should be pointing upward.

1. Drill a $\frac{9}{16}$ inch hole through the enclosure.
2. Insert the connector base through the hole so that the antenna side is on the outside, and the base is seated firmly against the enclosure surface.
3. Use the Figure 2.10: PulseStar•jr. External Antenna to assemble an external antenna.

Antenna Kit PS-66504000 has a 1.5-m cable, and Antenna Kit PS-66504001 has a 3.0-m cable, and antenna kit PS-66504002 has a 5.0m cable.

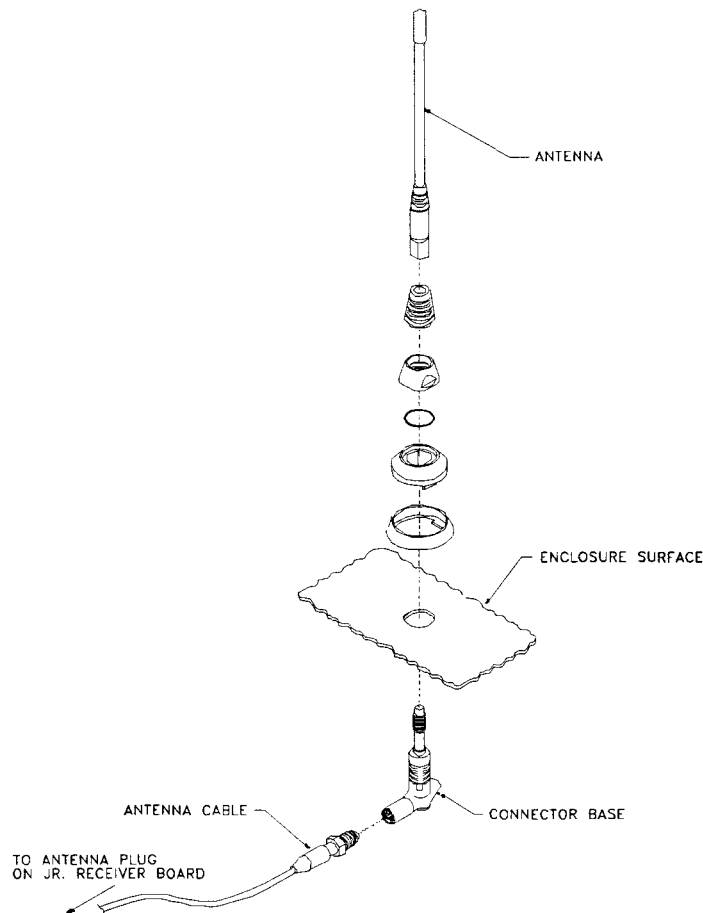

Figure 2.10: PulseStar•jr. External Antenna

4. Screw the antenna pole into the antenna body.
5. Snap the antenna cable connector into the antenna plug on the receiver circuit board.

Testing The Receiver

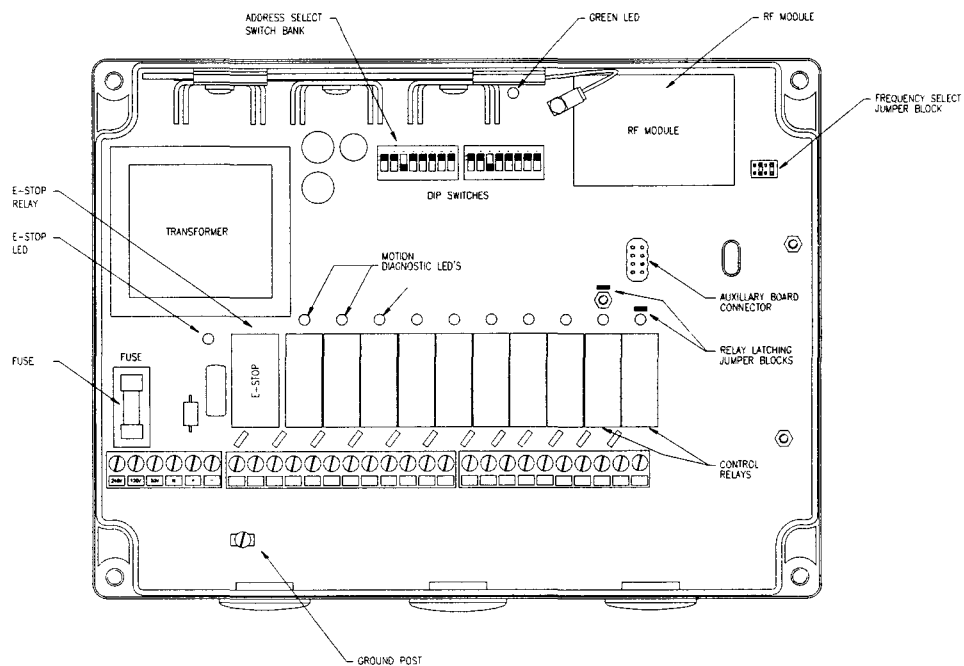

Figure 2.11

PulseStar•jr.—Receiver

1. Turn on the power to the receiver.
2. Make sure there is a charged battery in the transmitter.
3. Insert the key into the key switch opening and turn to the ON position. The green LED light on the transmitter flashes to indicate the power-up.
4. The green LED located near the radio frequency module in the receiver should start flashing. This indicates that the transmitter is communicating with the receiver.
5. Pull the red E-STOP button out and press the green START/HORN button on the transmitter to provide power to the mainline contactor. The horn will sound when supplied.
6. Test the **Active E-Stop** by pushing in the red mushroom E-STOP button. The mainline contactor should drop out.
7. Repeat step five above.
8. Depress the motion control buttons on the transmitter to test the crane functions. Confirm that the crane moves appropriately. The red LED's located by each relay should illuminate indicating that the particular relay is being activated.
9. If all transmitter and receiver functions work properly the system is ready for use.

Changing the Frequency of the Receiver

1. The frequency of the receiver and transmitter are set by Electromotive Systems prior to shipment. Should interferences occur on a particular frequency (channel) it may be necessary to change the frequency of the receiver and transmitter. Contact Electromotive Systems prior to making any frequency changes. **Do not change the address under any circumstances.**
2. The transmitter and receiver operate over the 400—470 MHz frequency range (70-cm band). There are 16 possible frequencies and 16 corresponding channels available. Figure 2.11: Frequency Diagram shows each channel, its respective frequency, and the position of the four jumpers according to the diagram for the frequency you are setting.

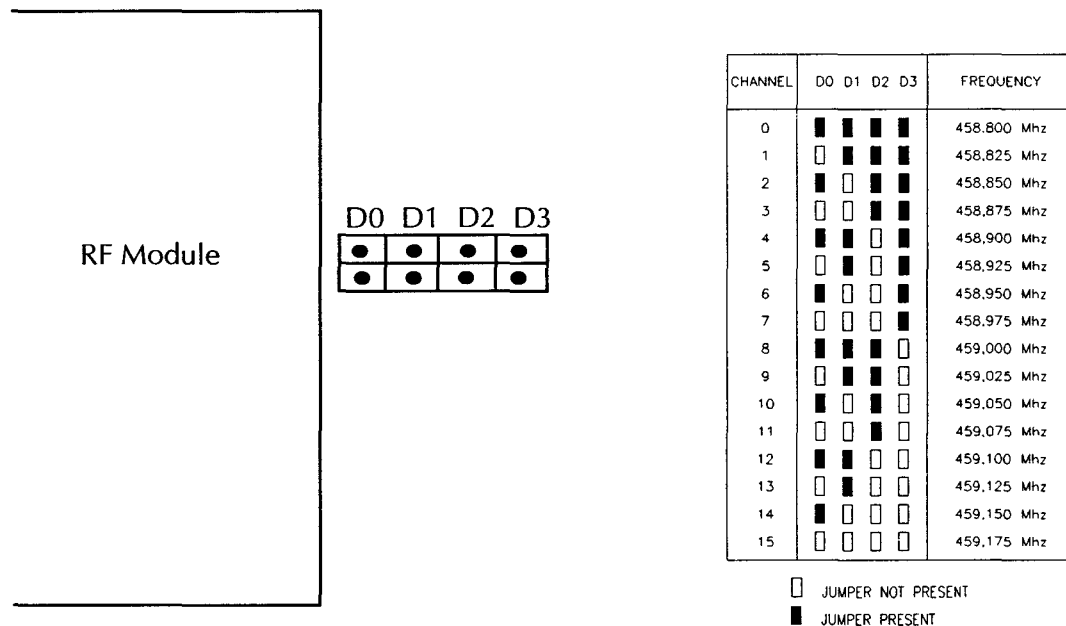

Figure 2.12: Frequency Diagram

The Relay Latching Option

Latching Functions are configured by Electromotive Systems to suit specific applications. To set the Relay Latching Option, insert a jumper according to the diagram below.

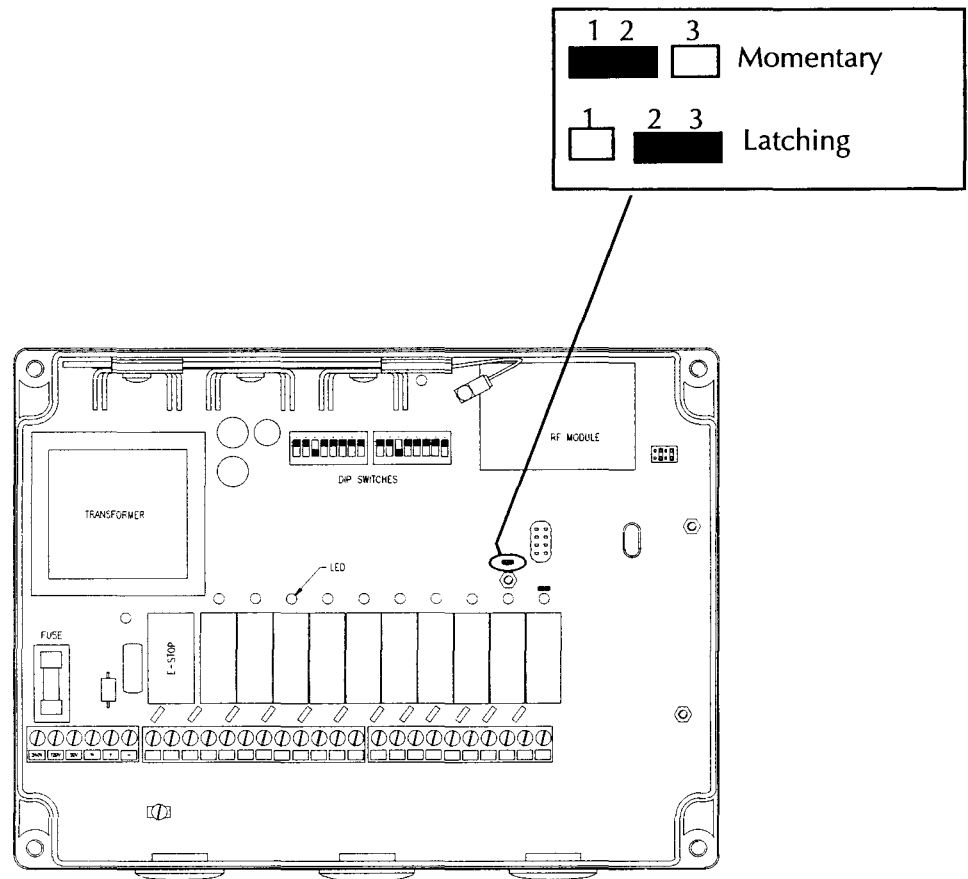

Figure 2.13

c h a p t e r **3**

Operating the JRT Transmitter

This page intentionally left blank.

Overview

The JRT transmitter is a hand-held radio control device with pushbuttons used to control crane motions. Each pushbutton operates with two detents. The JRT can control up to three crane motions. The JRT transmitter is designed specifically for use with the PulseStar•jr. receiver and may not be used with other PulseStar systems.

Once you've installed, wired, and tested the PulseStar•jr., you are ready to use it. This chapter covers the following information.

- Start-up and operation
- Setup of a spare or replacement transmitter
- Battery information

Start-up and Operation

Start-up

To start the JRT transmitter:

1. Make sure that there is a charged battery in the transmitter.
2. Pull out the red mushroom E-STOP button.
3. Insert the key into the key switch opening and turn to the ON position. The green LED light flashes to indicate power-up.
4. Press the START/HORN button to provide power to the mainline contactor.

The transmitter is now ready for use.

Holding the Transmitter

Before using the transmitter, refer to Figure 3.1: JRT Transmitter so that you hold the JRT the correct way.



WARNING

To make sure that you are oriented correctly in relation to the directional buttons, hold the transmitter as shown in Figure 3.1: JRT Transmitter. The end with the key switch and red E-STOP button should be pointing away from your body as you hold it.

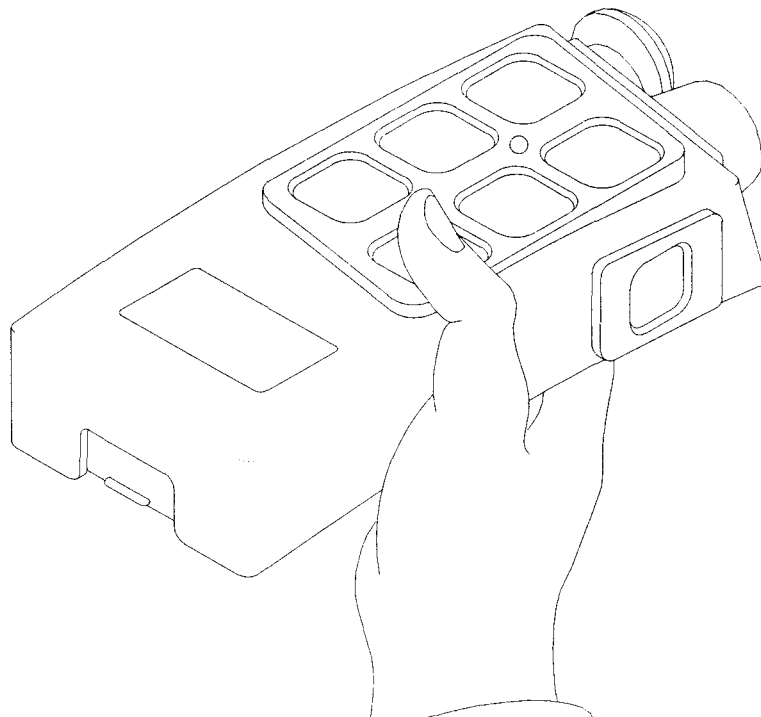

Figure 3.1: JRT Transmitter

Using the Transmitter Pushbuttons

The JRT transmitter can control up to three crane motions. Each pair of buttons corresponds to one crane motion. The pushbuttons are “interlocked,” which means that only one button in each horizontal row is operational at a time. In other words, if you press a button, the crane function corresponding to that button will be activated. If you then press the other button in the same row while still holding down the first button pressed, the receiver will ignore the crane motion corresponding to the second button pressed.

Shutting Off the Transmitter

When you are finished using the transmitter, turn the key switch to OFF. The mainline contactor will drop out after ten minutes. Remove the key switch and take it with you to prevent unintended use.

Emergency Stop

For all emergency situations, push in the red mushroom E-STOP button. To restart, turn the key switch ON, pull out the E-STOP button and depress the START/HORN button.

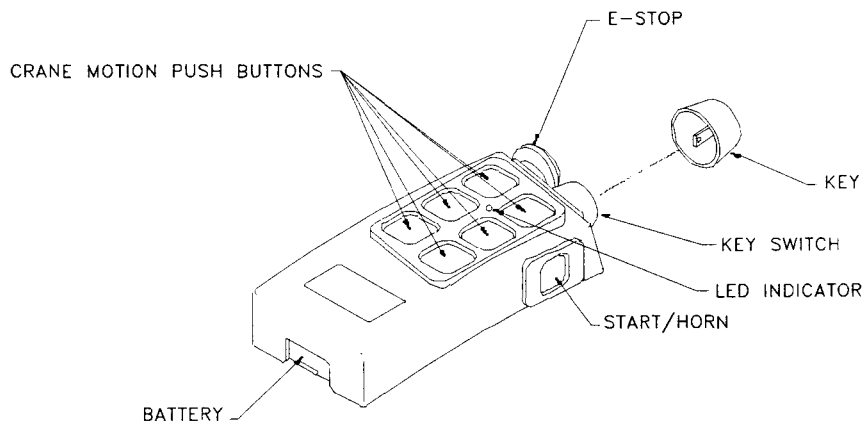

Figure 3.2: JRT Transmitter

Spare Transmitter Setup

This section covers how to set up a spare or replacement JRT transmitter.

Replacing the Pushbutton Legends

If your spare or replacement transmitter came with button legends that you need to manually insert, refer to Figure 3.3: JRT Transmitter and the following instructions. Do not operate the transmitter until all legends are properly installed.

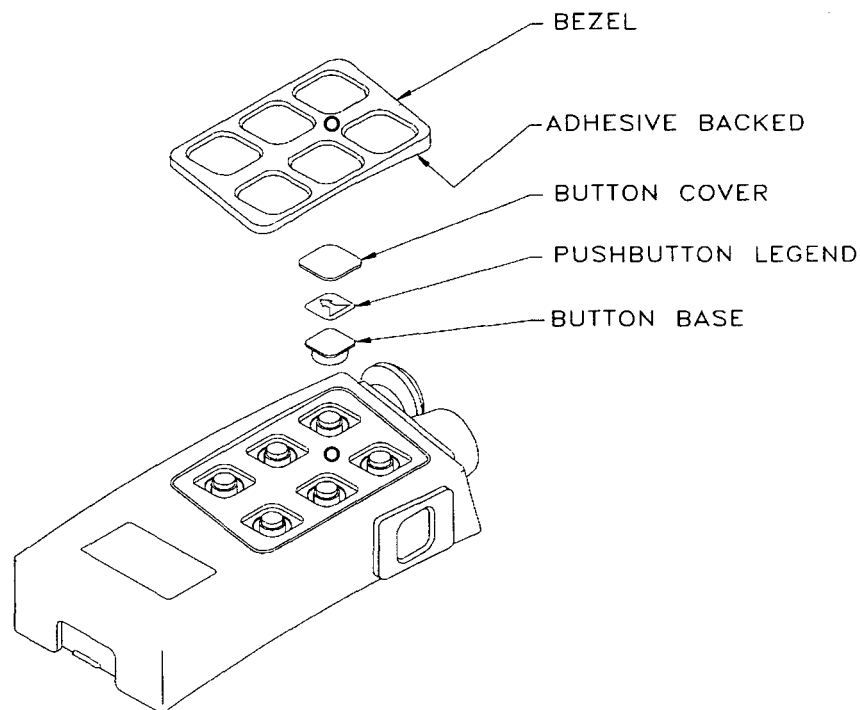

Figure 3.3: JRT Transmitter

1. Unsnap the button cover from the button base. Remove the button legend and replace it with the new legend. Place the legend in the grooves of the button cover face down so that when you turn the button over, the button legend is visible.
2. Snap the button base into the cover. Repeat steps 1 and 2 for each button legend you are replacing.
3. Assemble the buttons on the transmitter according to the layout for your application.
4. Ensure that the transmitter housing is free of dirt, oil and other contaminants or the bezel won't stick.
5. Once you are satisfied with the button layout, remove the adhesive strip on the back of the bezel and line it up on the enclosure. Press the bezel firmly into place.

Setting the Transmitter Address and Frequency



WARNING

This section explains how to set the address and frequency of the JRT transmitter. This should be done **ONLY** if you are setting up a spare or replacement transmitter.

- Do **NOT** change the address or frequency of the original JRT transmitter that came with your PulseStar•jr. system without first contacting Electromotive Systems.
- Do **NOT** change the address settings in the receiver.
- Ensure that you don't operate two transmitters set with the same frequency and address as the receiver at the same time.

Before setting the address and frequency of the transmitter, ensure you first know the address and frequency of the receiver it is going to control. To set the address or frequency of a spare transmitter:

1. Make sure the transmitter is off. Remove the key to be sure.
2. Remove the battery from the transmitter, refer to "Battery Information".
3. Remove the eight screws on the back of the JRT that fastens the back piece to the transmitter.
4. Remove the back piece to expose the inside of the transmitter.
5. Use Figure 3.4: Inside the JRT Transmitter to locate the two blocks of address DIP switches and the frequency jumpers inside the JRT transmitter enclosure.

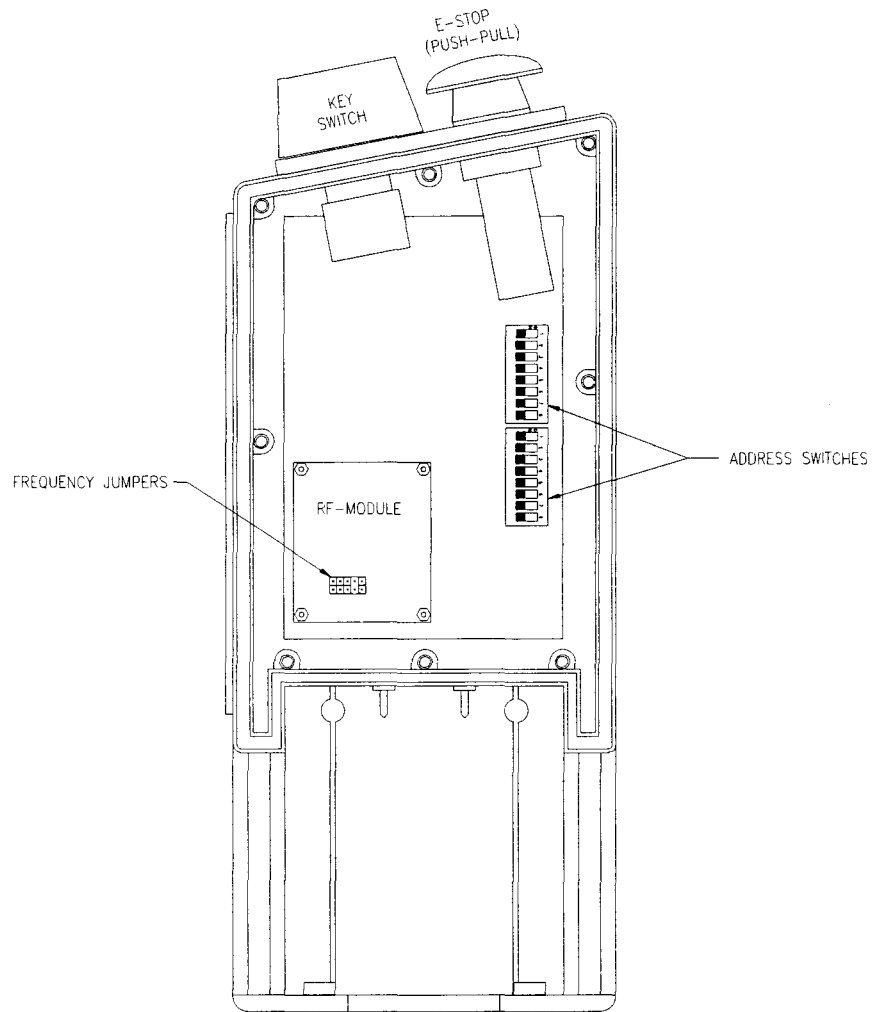

Figure 3.4: Inside the JRT Transmitter

Setting the Address

6. The address of the transmitter must be set to the address of the receiver it is going to control. Set the address DIP switches to the 16-bit address of the receiver.

Setting the Frequency

- The frequency of the transmitter must be set to the frequency of the receiver it is going to control. The transmitter and receiver operate over the 400–470 MHz frequency range (70-cm band). There are 16 possible frequencies and 16 corresponding channels available. Figure 3.5: Frequency Diagram shows each channel, its respective frequency, and the position of the four jumpers. Set the frequency jumpers according to the diagram for the frequency you are setting for the transmitter.

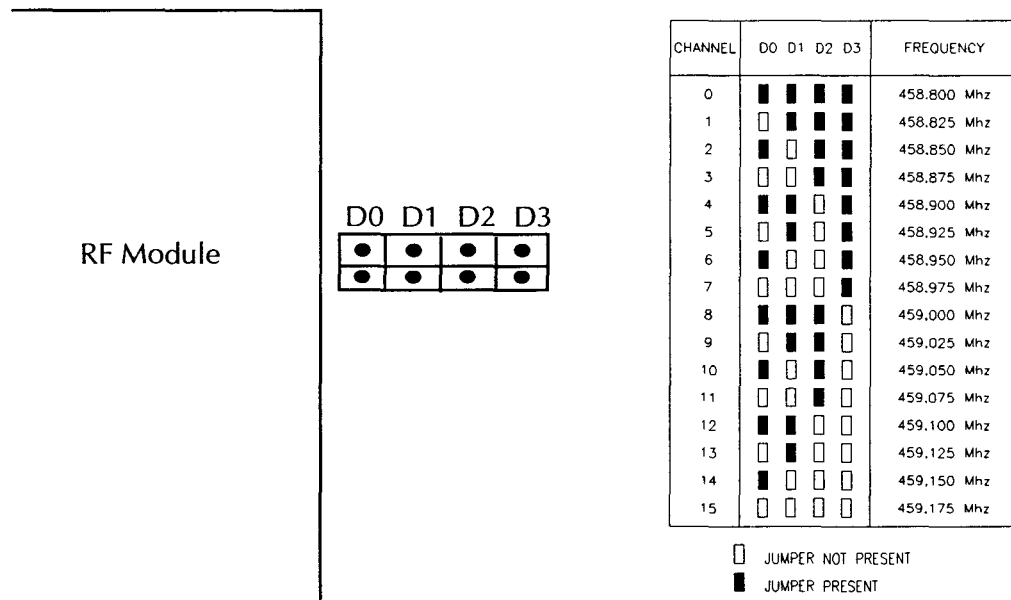

Figure 3.5: Frequency Diagram

- When finished, replace the back piece and tighten the eight screws.

Battery Information

When the JRT battery voltage drops below approximately 8 volts, the LED on the transmitter will begin flashing red for about 30 seconds. At the end of the 30-second period, the transmitter will automatically shut itself off and send an **Active E-Stop** command to block the crane motions.

The PulseStar battery charger is designed for 115/230VAC and plugs into a regular wall outlet.

Removing the Battery From the Transmitter

To remove the battery from the JRT transmitter, push the battery against the spring-loaded contacts until the battery pops out of the compartment. Refer to Figure 3.6: JRT Transmitter Battery to remove the battery.

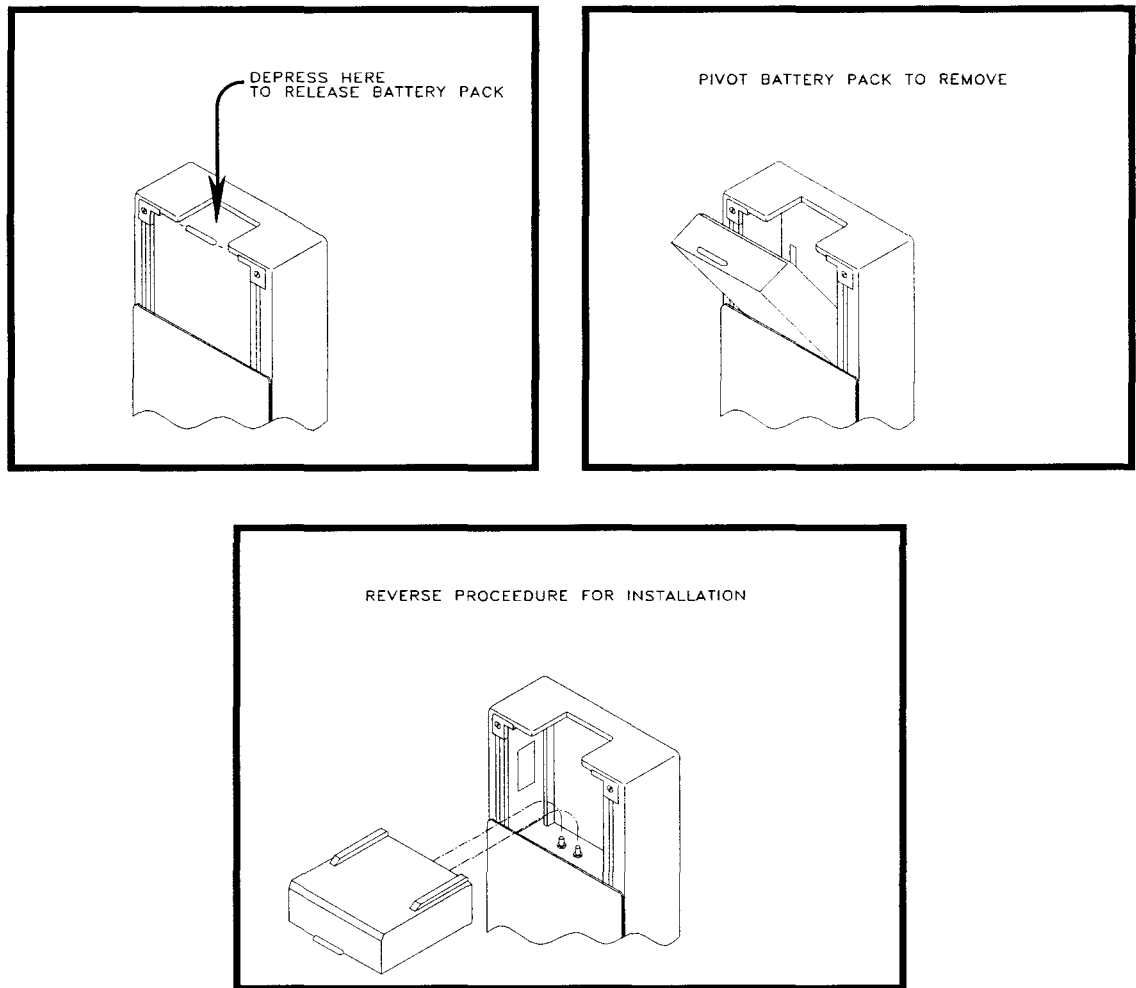

Figure 3.6: JRT Transmitter Battery

Charging the Battery

Insert the battery into the charger. The LED emits a steady green light to indicate that the battery is being charged.

The processor in the charger checks the actual charge state of the battery until the battery is fully charged. The maximum charging time is three hours. When the battery is fully charged, the green LED begins to flash. Leave the battery in the charger until needed to ensure it is fully-charged.

If the power supply to the charger is interrupted, or the battery is removed and then reinserted into the charger (before the battery was fully charged), the charger detects how much charge the battery has left and resumes the charging process.

The following table summarizes battery information of the JRT.

Charging Time	3 hours (from fully discharged)
Operation Time	7–9 hours
Type	Nickel-Cadmium; 9.6 Volts, 300 milliampere hours
Maximum number of charges	Approximately 800 times

All charger and battery contacts are gold-plated to provide superior contact. Batteries and chargers are IP65-rated.

The mechanical design of the battery case and the battery pocket ensures that each insertion and removal of the battery will clean the contacts. This is known as “self-cleaning” contacts.

Memory Effect

To maximize the lifetime of your nickel cadmium batteries, **only charge completely discharged batteries** whenever possible. Charging a partially discharged battery results in a memory effect in the battery, which reduces the number of times it can be effectively charged.

c h a p t e r **4**

**Troubleshooting
PulseStar•jr.**

This page intentionally left blank.

Troubleshooting

Introduction

This chapter covers what to do if the PulseStar•jr. does not seem to work properly. Review start-up test procedures for self-diagnostic indications, located on page 2-13. If, after trying the suggestions in this chapter, your unit still does not work, contact Electromotive Systems immediately at 1-800-288-8178.

Possible Causes of Nonfunctioning Transmitter

- E-STOP button not pulled out.
- Key switch in the OFF position.
- START/HORN button not pressed.
- START/HORN button was pressed while accidentally holding in one of the other buttons.
- Battery not in place or charged.
- Transmitter beyond its operating range of 330 feet.

Possible Causes of Nonfunctioning Receiver

Open the receiver enclosure and check the following:

- Connections/terminals are loose.
- Connection plug for the antenna is not firmly connected.
- Power supply and ground wire connections are not secure.
- Control wires are not separated from the high-voltage power wires.
- Frequency interference. **Contact Electromotive Systems for assistance prior to changing frequency.**
- Blown fuse. Check fuse and replace if necessary.

a p p e n d i x **A**

Definitions and Abbreviations

This page intentionally left blank.

Definitions and Abbreviations

Definitions

The following terms may be used in radio remote control discussion and may be unfamiliar to some operators.

Term	Definition
analog	Proportional-stepless or infinite control
baud	The transmitting speed measured in bits per second
decoder	Converts a serial data message into parallel signals
double superheterodyne	A method to build an extremely narrow band receiver by converting the receiver frequency twice.
encoder	Converts parallel signals into a serial data message
hamming distance	A measurement of data transmission safety. The higher the hamming distance, the safer the data transmission.
synthesizer technology	Used to electronically generate a carrier frequency.

Commonly Used Abbreviations

Abbreviation	Meaning
A/D	Analog to digital conversion
AK	Analog channel (German: Analog Kanal)
AMP	Ampere
AWG	American wire gauge
BPS	Bits per second
DK	Digital channel (German: Digital Kanal)
EMC	Electromagnetic compatibility
EMI	Electromagnetic immunity
EPROM	Electrical programmable read-only memory
FM	Frequency modulation
GND	Ground
HF	High frequency
KHz	Kilohertz
mAh	Milliamperere hours
mA	Milliamperere
msec	Millisecond
MHz	Megahertz
mW	Milliwatt
NiCd	Nickel-Cadmium
PLC	Programmable logic controller
PLL	Phased locked loop
PWM	Pulse width modulation

Abbreviation	Meaning
RF	Radio frequency (same as HF - high frequency)
RMS	Root mean squared
Rx	Receiver
RxD	Receiving data
SMD	Surface mount device
SMT	Surface mount technology
TTL	Transistor transistor logic
Tx	Transmitter
TxD	Transmitting data
Ub	Operating power
μv	Microvolts
VAC	Volts (alternating current)
VDC	Volts (direct current)

a p p e n d i x **B**

Specifications

This page intentionally left blank.

Specifications – PulseStar•jr.

System Specifications

Specification	Setting
Certification	TÜV, CE, and CUL
Temperature range	-22°F to 167°F (-30°C to 75°C)
Operating range	330 ft (100 m) ⁽¹⁾
Humidity range	0–95% maximum
Modulation	Narrow band—FM
Frequency range	400–470 MHz (16 preset frequencies)
Bandwidth	12.5 kHz/25kHz
Frequency generation	Microprocessor-controlled PLL Synthesizer
Microprocessor	Intel
Baud rate	4800 bps (approx. 55-msec response time)
Hamming distance	4
Security	16-bit addressing (more than 65,000 possibilities)

⁽¹⁾ Requires external antenna when mounted inside control enclosure.

JRT Transmitter Specifications

Specification	JRT setting
Weight	Less than 1.25 lbs (including battery)
Physical size (LxWxH)	8 in. x 3.5 in. x1.5 in. (21 cm x 8.7 cm x 4 cm)
HF output power	Maximum 10 mW
Deviation	±2kHz
Power supply	9.6-V Nickel-Cadmium rechargeable battery; 300 milliamp-hours
Operation time	7–9 hours with one charge
Enclosure	IP65 Weatherproof (exceeds NEMA 12/13)
Protection	Key switch with cap
Antenna	Built-in
Functions	Emergency-stop button (push/pull) 3 crane motions 2 speeds, interlocked Horn and mainline activation
Features	Sleep mode (10 minutes) Switch-ON protection Mechanical protection against accidental activation
Battery charger	115/220VAC (±20%) Charging time—3 hours Gold and self-cleaning contacts 2 batteries included

Receiver Specifications

Specification	Setting
Operating power	50/115/220 VAC ($\pm 20\%$), 12.24VDC ($\pm 50\%$)
Current	Less than 100 mAmps
HF part	Double superheterodyne
Sensitivity	0.4 microvolts (root mean-squared)
Safety	Fail-safe, spring-forced emergency-stop relay
Output	1 Emergency-Stop relay; 275VAC, 8 Amp/30VDC, 5 Amp 1 START/mainline relay; normally open; 275VAC, 8 Amp/30 VDC, 5 Amp 9 crane motion relays; 275VAC, 8 Amp/30VDC, 5 Amp
Enclosure	IP65 Weatherproof
Antenna	Built-In (External Antenna Optional)

a p p e n d i x **C**

StarService and Warranty

This page intentionally left blank.

StarService Policy

This chapter includes information pertaining to on-call service, transmitter loaner and Repair program and Receiver Replacement/Repair Program warranty. Before you install, troubleshoot, or service the drive, we highly recommend that you read this entire chapter. Doing this will help assure quick service response, minimize your on-site repair costs, and reduce crane downtime.

On-Call Service

If you ever have a problem with your PulseStar•jr. system, call Electromotive Systems at 1-800-288-8178. Technical support is available 24 hours a day, seven days a week. If necessary, Electromotive Systems can arrange to have a service technician visit your site to evaluate the situation (normally at your expense.)

Warranty

Every PulseStar product includes a two-year warranty from the date of shipment. The warranty is described in detail later in this chapter.

Transmitter Loaner & Repair Program

The PulseStar Transmitter Loaner & Repair Program provides a loaner transmitter while your transmitter is being repaired.

Under the terms of the Loaner and Repair Program, please provide a purchase order or credit card to cover the cost of the loaner transmitter.

If you need to return a defective JRT, please follow the steps below.

1. Request a Return Goods Authorization (RGA) from Electromotive Systems' Service Department and return the defective transmitter to Electromotive Systems **via pre-paid freight. When you call, please have the original serial number of the transmitter available and be prepared to provide the information requested on the Return Authorization Information Sheet found on page C-6.**
2. Electromotive Systems will inspect the defective transmitter and determine if the defects are covered under warranty.
 - If the defects are covered under warranty, Electromotive Systems will credit the full cost of the loaner transmitter, plus pay for all freight charges for both the loaner transmitter and the transmitter repaired under warranty.
NOTE: Freight charges incurred from sources other than common ground carriers WILL NOT be reimbursed unless pre-approved by Electromotive Systems.
 - If the defects are not covered under warranty, Electromotive Systems will credit the cost of the loaner transmitter, less the cost of the repairs, a \$50 loaner inspection fee, and any freight charges incurred by Electromotive Systems.
3. Electromotive Systems will ship a loaner transmitter within 24 hours.
4. Electromotive Systems will repair or replace the transmitter and return it to you within 72 hours of receipt (three working days).
5. Return the loaner transmitter in good condition to Electromotive Systems **via prepaid freight.**

Receiver Replacement/Repair Program

The process for returning a defective PulseStar•jr. receiver is described in the following steps.

1. Request a Return Goods Authorization (RGA) from Electromotive Systems' Service Department and return the defective receiver to Electromotive Systems via prepaid freight. When you call, please have the original serial number of the receiver available so that Electromotive Systems can set up the replacement receiver with the correct address and frequency. Also, please provide a purchase order or a credit card number to cover the cost of the replacement receiver. You are responsible for the shipping charges for sending the defective parts to Electromotive Systems.
2. Electromotive Systems will send out a replacement receiver within 24 hours. The receiver will be configured with the correct address and frequency.
3. Electromotive Systems will inspect the receiver and determine if the defects are covered under warranty.
 - If the defects are covered under warranty, Electromotive Systems will credit the full cost of the PulseStar•jr. receiver, plus pay for all freight charges.

NOTE: Freight charges incurred from sources other than common ground carriers WILL NOT be reimbursed unless pre-approved by Electromotive Systems.

- If the defects are not covered under warranty, you are responsible for the cost of the replacement PulseStar•jr. receiver, the inspection cost of \$50.00, and all freight charges.

Electromotive Systems Limited Warranty

Electromotive Systems, Inc., hereafter referred to as Company, guarantees all items manufactured by it against any defects of material and/or workmanship for a period of two years from the date of shipment. Company makes NO OTHER WARRANTY, EXPRESSED OR IMPLIED, AS TO THE MERCHANTABILITY OR FITNESS OF THE ITEMS FOR THEIR INTENDED USE OR AS TO THEIR PERFORMANCE. Any statement, description or specification in Company's literature is for the sole purpose of identification of items sold by the Company and imparts no guarantee, warranty or undertaking by company of any kind. Components and accessories not manufactured by Electromotive Systems are not included in this warranty and are warranted separately by their respective manufacturers.

Company's sole liability shall be to repair at its factory, or replace any item returned to it within two years from date of shipment, which Company finds to contain defective material or workmanship. All items to be repaired or replaced shall be shipped to Company (Note: return authorization by Company is required) within said two year period, freight prepaid, as a condition to repair or replace defective material or workmanship. Company's herein assumed responsibility does not cover defects resulting from improper installation, maintenance, or improper use. Any corrective maintenance performed by anyone other than the Company during the warranty period shall void the warranty. Company shall not be liable for damages of any kind from any cause whatsoever beyond the price of the defective Company supplied items involved. Company shall not be liable for economic loss, property damage, or other consequential damages or physical injury sustained by the purchaser or by any third party as a result of the use of any Company supplied items or material.

Company neither assumes nor authorizes any other person to assume for Company any other liability in connection with the sale or use of items sold by Company.

Materials or items may not be returned for credit, without the prior written consent of the Company. Any authorized return of materials or items shall be subject to a restocking charge equal to 25% of the net invoiced amount (\$100 minimum charge for all control products) after Company determines that the material or item is in resalable condition. If upon receipt of the material or items returned, the Company determines that said material or items cannot be resold without alteration or service, the Company reserves the right to reject the returned materials or items and to send the same back to said purchaser at purchaser's expense.

Any claim for errors in shipment or for material or time shortages must be received by Company within 30 days of shipment and must be accompanied by copies of the bill of lading and packing slip.

ELECTROMOTIVE SYSTEMS, INC.
RETURN AUTHORIZATION INFORMATION SHEET

To Expedite Processing Complete This Form

Please provide us with the information on lines with checked. If you have any questions regarding the completion of this form contact Electromotive Systems Service Department at 800-288-8178 ex 375

1. Return Authorization Number: RA _____ Issue Date ___/___/___
2. Customer _____
3. Customer P.O. Number _____
4. Contact Name _____ Phone _____ FAX _____
5. End User (name/location) _____
6. Component Model _____
7. Component Serial Number _____

ABOVE MATERIAL TO BE RETURNED VIA PRE PAID FREIGHT TO:

Electromotive Systems, Inc.
N49 W13650 Campbell Drive
Menomonee Falls, WI 53051

*Please enclose a copy of this form with material to be returned and
mark RA number clearly on shipping container*

APPLICATION INFORMATION

8. Type of application (i.e., Mill, Log Handling, Standard Industrial): _____
9. Crane Duty Cycle: CMAA A B C D E F (circle)
10. Motion: ___ Main Hoist ___ Aux Hoist ___ Bridge ___ Trolley
___ Other (please specify) _____
11. Describe conditions under which problem occurred _____
12. Make/Model Dynamic Braking Resistor: _____
13. Line Voltage ___ 230 ___ 460 ___ 575 ___ Other (specify) _____
14. Motor Information: Qty ___ 1 ___ 2 ___ Other (please specify) _____
_____ Motor RPM _____ Nameplate Full Load Amps
15. Reactors used ___ Line ___ Load ___ None

FOR WARRANTY INFORMATION SEE BACK OF THIS FORM

Control number 1584

Original Date: 04/08/97

Rev 00

Page 1 of 1