

---

**PulseStar<sup>®</sup> • jr.**

---

Remote Crane Controls

---

# Instruction Manual



**ELECTROMOTIVE SYSTEMS**  
by **M** *MagneTek*

PSJRINST-99A 206/306 Series September 1, 1999  
Part Number: 900-4125

© Copyright 1999 Electromotive Systems

©1999 ELECTROMOTIVE SYSTEMS

All rights reserved. This notice applies to all copyrighted materials included with this product, including, but not limited to, this manual and software embodied within the product. This manual is intended for the sole use of the persons to whom it was provided, and any unauthorized distribution of the manual or dispersal of its contents is strictly forbidden. This manual may not be reproduced in whole or in part by any means whatsoever without the expressed written permission of ELECTROMOTIVE SYSTEMS

## ***DANGER, WARNING, CAUTION, and NOTE* Statements**

*DANGER, WARNING, CAUTION, and Note* statements are used throughout this manual to emphasize important and critical information. You must read these statements to help ensure safety and to prevent product damage. The statements are defined below.



### **DANGER**

*DANGER* indicates an imminently hazardous situation which, if not avoided, will result in death or serious injury. This signal word is to be limited to the most extreme situations.



### **WARNING**

*WARNING* indicates a potentially hazardous situation which, if not avoided, could result in death or serious injury.



### **CAUTION**

*CAUTION* indicates a potentially hazardous situation which, if not avoided, could result in minor or moderate injury. It may also be used to alert against unsafe practices.

*NOTE:* A *NOTE* statement is used to notify people of installation, operation, programming, or maintenance information that is important, but not hazard-related.



## **WARNING**

- This manual instructs you how to use PulseStar<sup>jr</sup>. If you disregard the instructions, information, and/or warranty in the manual, you could be assuming responsibility for damages, costs, or injury incurred by such disregard.
- Do not touch any circuit components on the circuit board while the main AC or DC power is on.
- Do not make any address code or frequency channel changes in the transmitter or receiver without first contacting Electromotive Systems.

# Contents

Welcome! .....	v
PulseStar JRT-206 System .....	vi
PulseStar JRT-206-2 System .....	vii
PulseStar JRT-306 System .....	viii
How to Use This Manual .....	ix
Important System Information .....	ix

## Chapter 1: PulseStar•jr. System Overview

PulseStar•jr. System Overview .....	1-3
Introduction .....	1-3
Theory of Operation .....	1-3
Active Emergency Stop (E-Stop) Function .....	1-3
Sleep and Time-Out Modes .....	1-4
Transmitter Sleep Mode .....	1-4
Receiver Safe Mode and Ten Minute Time-Out Mode .....	1-4

## Chapter 2: Installing and Wiring the PulseStar•jr. Receiver

Overview .....	2-3
Receiver Components .....	2-4
Installing the PulseStar•jr. Receiver .....	2-5
Assessing the Receiver Enclosure Environment .....	2-5
Serial Nameplate .....	2-5
Mounting PulseStar•jr. Receiver .....	2-6
Wiring the PulseStar•jr. Receiver .....	2-7
Connecting a Standard External Antenna .....	2-12
Connecting a Gain Flex Antenna .....	2-13
Start-up and Test Procedures .....	2-14
Pre-operation Check List .....	2-14
Testing The Receiver .....	2-15
Changing the Frequency Channel of the Receiver .....	2-17
Relay Latching Option .....	2-19

## Chapter 3: The PulseStar•jr. Transmitter

Overview .....	3-3
PulseStar•jr. Transmitter .....	3-4
JRT-5 Transmitter Components .....	3-4
JRT-5 Transmitter Functions .....	3-5
Transmitter Setup .....	3-6
Placing the Push-button Labels .....	3-6
Transmitter Address Code and Frequency Channel .....	3-7
Setting the Address Code and Frequency Channel of a Transmitter: .....	3-8
Start-up and Operation .....	3-12
Holding the Transmitter .....	3-12
Start-up .....	3-13
Shutting Off the Transmitter .....	3-13
Transmitter Options .....	3-14
Spare Transmitter .....	3-14
Battery and Charger Information .....	3-15
Removing and Inserting the Battery From the Transmitter .....	3-15
Charging the Battery .....	3-16
Memory Effect .....	3-17

## Chapter 4: Troubleshooting PulseStar•jr.

Troubleshooting .....	4-3
Introduction .....	4-3
Common Problems .....	4-3
Questions to Ask .....	4-5

## Appendix A: Definitions and Abbreviations

Definitions and Abbreviations .....	A-3
Definitions .....	A-3
Commonly Used Abbreviations .....	A-4

## **Appendix B: Specifications**

Specifications .....	B-3
System Specifications .....	B-3
JRT Specifications .....	B-3
Receiver Specifications .....	B-4

## **Appendix C: StarService and Warranty**

StarService Policy .....	C-3
On-Call Service .....	C-3
Warranty .....	C-3
Transmitter Loaner, Replacement & Repair Program .....	C-3
Receiver Repair Program .....	C-4
Limited Warranty And Terms Of Sale .....	C-5
Special Terms and Conditions: Orders of \$25,000 or More .....	C-6
Special Terms and Conditions: Orders for Special Control Panels .....	C-6

# Welcome!

Welcome to the PulseStar•jr. radio remote crane control system. Electromotive Systems has set a whole new standard in radio-remote performance, dependability, and value with this unique new line of modular transmitters and receivers. Without a doubt, PulseStar•jr. is the ultimate solution for having precise, untethered, and safe control of overhead loads.

Using state-of-the-art synthesizer technology and the best circuit board manufacturing designs available, Electromotive Systems has eliminated many of the unreliable and expendable electromechanical components found in traditional radio remote systems.

The PulseStar•jr. system consists of a receiver and a hand held transmitter. The system uses PulseStar's synthesizer technology and operates over the 400-470 MHz band. PulseStar•jr. is FCC approved with no site license required.

PulseStar's unique transmitter and receiver design provide a sophisticated, yet easy-to-understand, efficient, and safe radio remote control. PulseStar's modular design has the following advantages:

- Flexible design allows easy mixing and matching.
- On-board diagnostics allow easy troubleshooting.
- Standardized spare parts; kits available.
- Simple design.

## PulseStar JRT-206 System

The PulseStar JRT-206 system consists of a JRX-6 receiver and JRT-5 transmitter kit. The JRT-206 system is normally used for remote control of one (1) two motion, single-speed crane or monorail carrier with hoist.

### JRX-6 Receiver

The JRX-6 receiver is provided with:

- Six motion relays for discreet output to adjustable frequency drives and/or contactors.
- **Active E-STOP** relay.
- Self-diagnostics to ensure trouble-free operation.
- 16-bit address security code (over 65,000 possibilities).
- Internal antenna with 330 foot range.
- IP66 weatherproof enclosure.

### JRT-5 Transmitter Kit

The JRT-5 three motion transmitter kit is provided with:

- JRT-5 transmitter.
  - Six two detent motion push-buttons.
  - **START/HORN** push-button (not used with the JRT-206 system).
  - **Active E-STOP** for immediate stopping action.
  - **Sleep Mode** to increase battery life and enhance safety.
  - Removable key switch for added security.
  - 16-bit address security code (over 65,000 possibilities).
  - Internal antenna with 330 foot range.
  - IP65 weatherproof enclosure.
  - Carrying holster with belt clip.
- Battery charger.
- Two rechargeable batteries.

## PulseStar JRT-206-2 System

The PulseStar JRT-206-2 system consists of a JRX-6-2 receiver and JRT-5 transmitter kit. The JRT-206-2 system is normally used for remote control of one (1) two motion, two speed crane or monorail carrier with hoist.

### JRX-6-2 Receiver

The JRX-6-2 receiver is provided with:

- Six motion relays for discreet output to adjustable frequency drives and/or contactors.
- **Active E-STOP** relay.
- Self-diagnostics to ensure trouble-free operation.
- 16-bit address security code (over 65,000 possibilities).
- Internal antenna with 330 foot range.
- IP66 weatherproof enclosure.

### JRT-5 Transmitter Kit

The JRT-5 three motion transmitter kit is provided with:

- JRT-5 transmitter.
  - Six two detent motion push-buttons.
  - **START/HORN** push-button (not used with the JRT-206 system).
  - **Active E-STOP** for immediate stopping action.
  - **Sleep Mode** to increase battery life and enhance safety.
  - Removable key switch for added security.
  - 16-bit address security code (over 65,000 possibilities).
  - Internal antenna with 330 foot range.
  - IP65 weatherproof enclosure.
  - Carrying holster with belt clip.
- Battery charger.
- Two rechargeable batteries.

## PulseStar JRT-306 System

The PulseStar JRT-306 system consists of a JRX-6 receiver and JRT-5 transmitter kit. The JRT-306 system is normally used for remote control of one (1) three motion, single-speed crane.

### JRX-6 Receiver

The JRX-6 receiver is provided with:

- Six motion relays for discreet output to adjustable frequency drives and/or contactors.
- **Active E-STOP** relay.
- Self-diagnostics to ensure trouble-free operation.
- 16-bit address security code (over 65,000 possibilities).
- Internal antenna with 330 foot range.
- IP66 weatherproof enclosure.

### JRT-5 Transmitter Kit

The JRT-5 three motion transmitter kit is provided with:

- JRT-5 transmitter.
  - Six two detent motion push-buttons.
  - **START/HORN** push-button (not used with the JRT-306 system).
  - **Active E-STOP** for immediate stopping action.
  - **Sleep Mode** to increase battery life and enhance safety.
  - Removable key switch for added security.
  - 16-bit address security code (over 65,000 possibilities).
  - Internal antenna with 330 foot range.
  - IP65 weatherproof enclosure.
  - Carrying holster with belt clip.
- Battery charger.
- Two rechargeable batteries.

## How to Use This Manual

*PulseStar•jr. Instruction Manual* has a comprehensive introduction chapter that you should read before installing, wiring, or operating the system. It introduces some of the PulseStar features, and the different components of the system.

Chapter 2 covers installing and wiring the receiver, as well as start-up and test procedures to make sure the system is working properly before you begin regular operation.

Chapter 3 covers address code and frequency channel setup, start up, and how to operate the PulseStar•jr. transmitter.

Chapter 4 gives you a basic troubleshooting guide, plus a checklist of things to look for before calling Electromotive Systems for service. In most cases, problems are minor and easy to solve.

## Important System Information

Before operating PulseStar•jr., read this important system information.

- Resistor-Capacitor surge suppressors must be used when the PulseStar•jr. receiver is controlling magnetic contactors.
- When not in use, the transmitter should be turned off and stored in a safe place to prevent unauthorized users from operating it.
- If the crane fails to respond properly, stop operation immediately, turn off the transmitter, and report the condition immediately to an appropriate technician or supervisor.
- Wire the receiver circuit board to the crane's ground.
- When using a standard external antenna mount it on a conductive metal surface with the same ground as the receiver circuit board. Remove any burrs from the antenna mounting hole and scrape away any paint which may prohibit the antenna base from making a good ground contact with the surface. Make sure that the antenna is not surrounded by metal or other conductive materials. Failure to properly install the antenna will result in intermittent operation.
- When using a gain flex external antenna make sure that your mounting location is at least 2 meters (6 feet) from any metallic or conductive objects. These objects will interfere with the antenna and cause intermittent operation.
- Before working on the transmitter, turn off the key switch and remove the battery is available.
- When taking a break or changing the battery, turn the transmitter off with the key switch.
- Always have a battery in the battery charger to ensure a fully charged battery.
- Perform initial setup or service work only if you have been authorized to do so. Use only Electromotive Systems spare parts.
- If your facility has more than one PulseStar remote radio control system, and the systems operate within 200 feet of one another, the frequency channels for each system must be at least two channels apart. If the systems operate within 50 feet of one another, the frequency channel for each system must be at least three channels apart.

*c h a p t e r* **1**

---

**PulseStar•jr.  
System Overview**

# PulseStar•jr. System Overview

## Introduction

This chapter introduces the basic conceptual information that you should know before installing, wiring, and operating PulseStar•jr.

## Theory of Operation

The PulseStar•jr. system consists of a receiver and a transmitter. The transmitter, using PulseStar's synthesizer technology, electronically generates a frequency over which it and the receiver communicate. PulseStar transmitters and receivers operate over the 400–470 MHz frequency range (70-cm band). To ensure safety when the crane is being operated in conjunction with other radio controls, the receiver and transmitter are configured with the same address code and frequency channel. This way, the receiver only accepts commands from the transmitter with the same address code and frequency channel.

**NOTE:** *The PulseStar•jr. transmitter and receiver already have their address code and frequency channel set before they are shipped. Never change the address code in the receiver. The only time you need to change the address code and/or frequency channel inside the transmitter is when you are setting up a spare or replacement transmitter, or when there is interference on a particular frequency channel. Contact Electromotive Systems before changing the frequency channel.*

## Active Emergency Stop (E-Stop) Function

One of the most important features of the PulseStar•jr. is **Active E-STOP**. The transmitter continuously sends the **Active E-STOP** status signal, followed by the desired crane function. This constant communication between the transmitter and the receiver confirm that the ongoing operations are safe. If the **Active E-STOP** push-button is pressed on the transmitter, the **Active E-STOP** relay module in the receiver opens, and crane motion then ceases. The receiver is then in **Safe Mode**.

To restart the system after activating **Active E-STOP** via the **Active E-STOP** push-button, pull out the **Active E-STOP** push-button.

**NOTE:** *There are other situations in which the system automatically goes into Active E-STOP without the operator pressing the Active E-STOP push-button on the transmitter. These are explained in later sections of the manual.*

**Active E-STOP** responds faster than any other PulseStar function. When **Active E-STOP** occurs, the system ignores any other signal it receives. **Active E-STOP** is the only signal that is recognized until the problem is corrected.

**Active E-STOP** is fail-safe and self-monitoring in both the transmitter and receiver. When you apply power to the receiver, it performs a self-test to make sure the **Active E-STOP** circuitry is working properly. If the receiver detects an error in the **Active E-STOP** circuitry, the system automatically goes into **Safe Mode**.

When you first turn on the transmitter, it also performs a self-test to make sure CPU circuitry is working properly. If it detects an error, the transmitter will not begin transmitting.

# Sleep and Time-Out Modes

## Transmitter Sleep Mode

To prevent accidental operation, PulseStar•jr. transmitters have a built-in safety feature called **Sleep Mode**. If a transmitter is not used for 10 minutes, it turns itself off. While the transmitter is in **Sleep Mode**, the push-buttons will not operate. To restart the transmitter cycle power (turn the key off and back on).

## Receiver Safe Mode and Ten Minute Time-Out Mode

Another PulseStar•jr. safety feature is the receiver **Safe Mode** and **Ten Minute Time-Out Mode**. The receiver will go into **Safe Mode** if any of the following should occur.

- The transmitter goes into **Sleep Mode**.
- Interference caused by other transmitters or other radio-controlled products in the area.
- The transmitter is taken out of its operating range (330 feet).
- The **Active E-STOP** push-button is activated.
- There is a failure with the **Active E-STOP** circuitry.

When the receiver loses the transmitter carrier frequency signal, the **Time Out Waiting Period** process begins. The **Time Out Waiting Period** is factory set at 450msec, however it can be extended to 2 seconds. Once the **Time Out Waiting Period** expires and the receiver still has not detected a valid signal the receiver goes into **Ten Minute Time-Out Mode**. The receiver blocks all the crane motion commands to avoid any accidental crane movement. The emergency stop relay remains closed and the mainline contactor is still active. The receiver then begins a ten-minute timer. If the receiver does not detect a valid signal within that period, it goes into **Safe Mode**. When in **Safe Mode** the receiver shuts off power to the output modules, and drops out the mainline contactor by opening the **Active E-STOP** relay.

**NOTE:** *Ten Minute Time-Out Mode can be disabled by changing a jumper setting, in which case, the receiver will go into Safe Mode immediately upon loss of signal. Consult Electromotive Systems to disable this feature.*

*c h a p t e r* **2**

---

**Installing and Wiring the  
PulseStar•jr. Receiver**

# Overview

This chapter tells you how to install and wire the PulseStar•jr. receiver. It also contains start-up test procedures so you can ensure that the transmitter(s) and receiver(s) are working properly before you actually use them to control the overhead crane.

This chapter covers the following information.

- Receive Components.
- Installing the PulseStar•jr. Receiver.
- Start-up and Test Procedures.



## WARNING

Only authorized personnel are permitted to perform the initial setup or service work. Use only Electromotive Systems spare parts.

# Receiver Components

The PulseStar•jr. receiver receives commands from the remote transmitter, and interfaces with the crane controls to move the crane. Figure 2.1: PulseStar Receiver Layout shows the components which make up the PulseStar receiver.

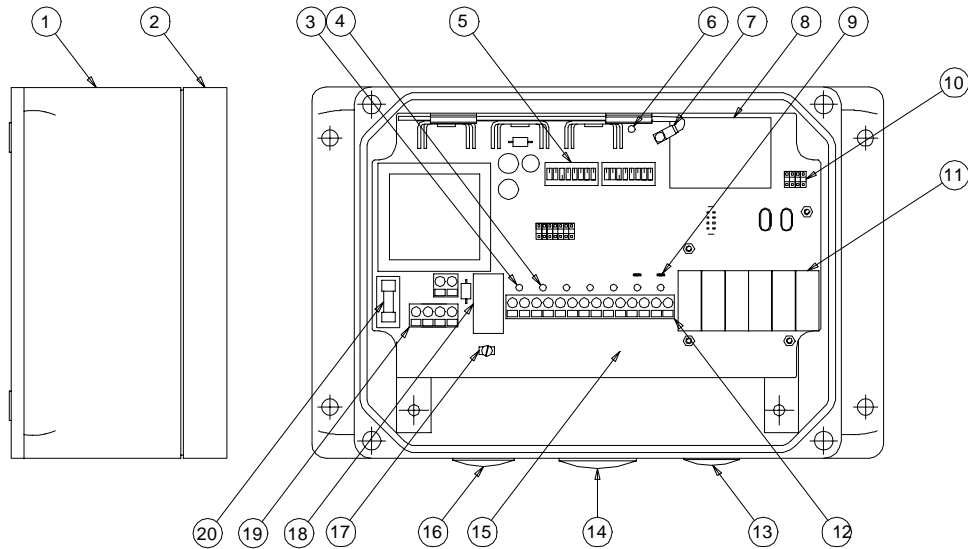

**Figure 2.1: PulseStar Receiver Layout**

- |  |  |
|--|--|
| 1. Receiver Enclosure                      | 11. Normally Open Motion Output Relay (1 of 6) |
| 2. Receiver Cover                          | 12. Output Terminal Block                      |
| 3. Active E-STOP LED                       | 13. Hole Plug PG-13.5                          |
| 4. Motion Relay LED                        | 14. Hole Plug PG-21                            |
| 5. Address Code Switches                   | 15. Receiver Printed Circuit Board             |
| 6. Telegram LED                            | 16. Hole Plug PG-16                            |
| 7. Internal Antenna                        | 17. Ground Post                                |
| 8. RF Module                               | 18. Active E-STOP Relay                        |
| 9. Latching Function Jumper Block (1 of 2) | 19. Incoming Power Terminal Block              |
| 10. Frequency Channel Jumper Block         | 20. Fuse                                       |

# Installing the PulseStar•jr. Receiver



## WARNING

- Only authorized personnel are permitted to perform the initial setup or service work. Use only Electromotive Systems parts.
- Do NOT touch any circuit components on the circuit board while the main AC or DC power is on.
- Do NOT change the address code settings in the receiver.
- Do NOT run control wires with power wires.
- Surge Suppressors must be used with all magnetic contactors that are controlled by the PulseStar•jr. system.

## Assessing the Receiver Enclosure Environment

When you choose a location for the receiver enclosure, consider the following guidelines.

1. The Receiver can be operated on the following power supplies:
  - 12-24V, DC (+/-50%).
  - 50/110/240V (+/- 20%), AC, Single Phase.
2. Ensure that the receiver enclosure will be protected or isolated from:
  - Ambient temperatures outside the range of -18°F to 158°F (-25°C to +70°C) (Consult Electromotive Systems if you must exceed this temperature range).
  - Corrosive gases or liquids.
3. As much as possible, ensure that the receiver is not surrounded by metal or other conductive materials that could prevent the internal antenna from receiving the transmitter signal. If you are using an external antenna, ensure that it is not surrounded by metal or other conductive materials.

## Serial Nameplate

Before you prepare to mount the receiver, locate the serial nameplate. The receiver serial nameplate is typically located on the right hand side of the enclosure. The serial nameplate contains the Electromotive Systems job number, the address code used by the system, and the frequency channel used by the system. **The Electromotive Systems job number is important if you ever need to call Electromotive Systems for service.** When you mount the receiver, ensure that the serial nameplate is visible so that you can easily read the Electromotive Systems job number.

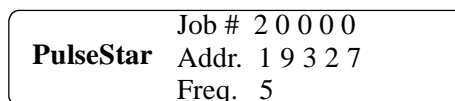

*Figure 2.2: Serial Nameplate*

## Mounting PulseStar•jr. Receiver

Use Figure 2.3: JRX-6 Enclosure Mounting Dimensions for dimensions and mounting hole spacing.

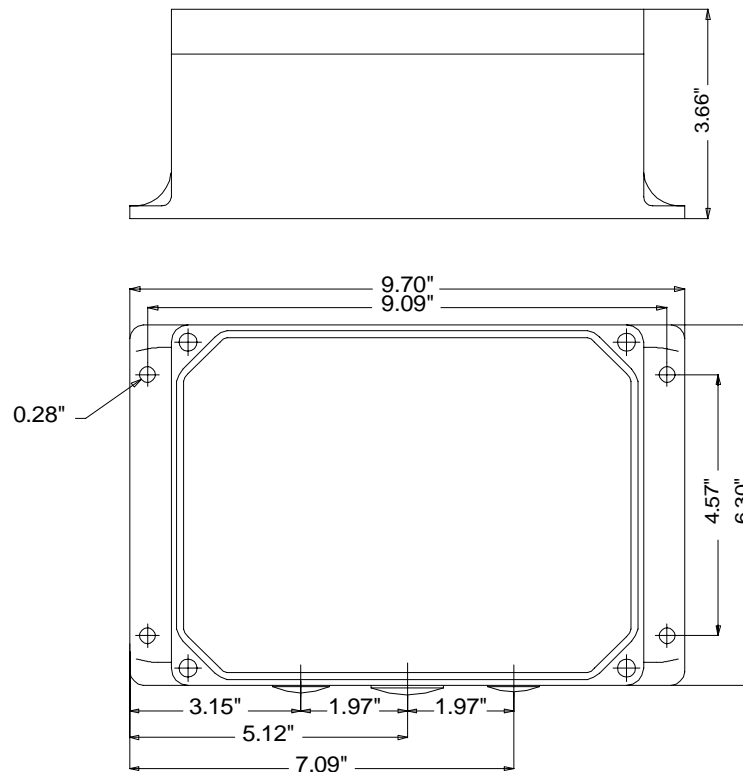

**Figure 2.3: JRX-6 Enclosure Mounting Dimensions**

1. Determine the position of the receiver enclosure. Position the enclosure so that the plug holes are on the bottom or on the side.
2. Refer to Figure 2.3: JRX-6 Enclosure Mounting Dimensions. Drill holes 7 mm in diameter (.28 in.) into the mounting surface. The depth of the hole depends on the type of screw you are using to mount the receiver enclosure.
3. Insert screws through each of the four mounting holes then tighten the four mounting screws to the mounting surface.
4. Determine the sizes and connection locations for the components that need to be wired.
5. Remove the hole plug(s) you are going to use for control and/or power wires.
6. Lay out the wire runs. At a minimum, use #18-AWG wire for control wiring.

# Wiring the PulseStar•jr. Receiver

The following wiring diagrams represent different PulseStar•jr. applications. Select the wiring diagram which matches your application.

## JRT-206 and JRT-306

Refer to Figure 2.4: PulseStar JRT-306 Wiring Diagram to wire the PulseStar•jr. receiver to the crane controls. The JRT-206 system is wired the same as the JRT-306 system, except it does not have a third motion.

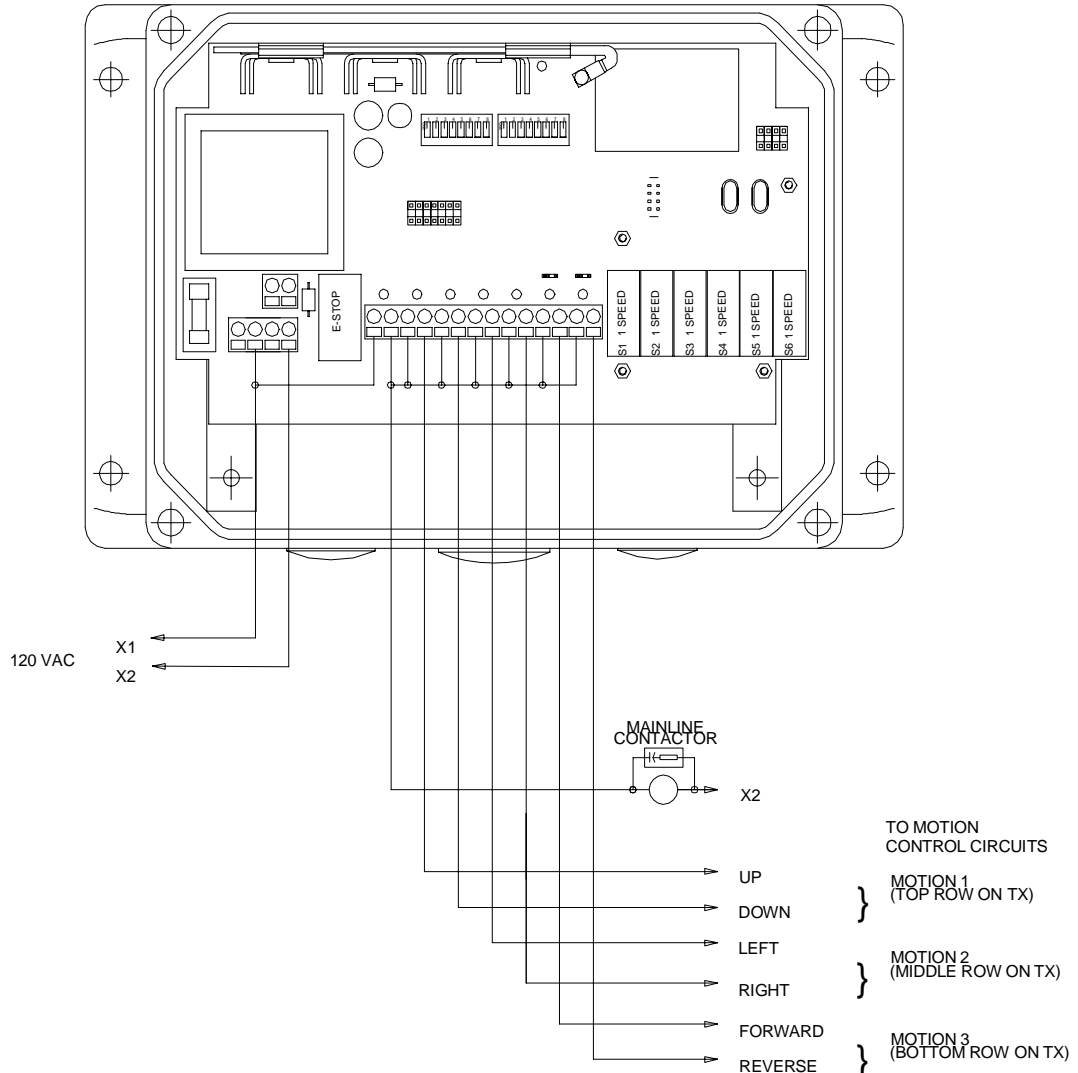

Figure 2.4: PulseStar JRT-306 Wiring Diagram

## JRT-206 and JRT-306 with Pendant

Refer to Figure 2.5: PulseStar JRT-306 Wiring Diagram with Pendant to wire the PulseStar•jr. receiver to the crane controls when a back-up pendant is used. The JRT-206 system is wired the same way as the JRT-306 system, except it does not have a third motion.

**NOTE:** *The radio/pendant transfer switch shown does not provide total isolation between the radio control system and the pendant station. It is recommended that when the transfer switch is in “radio” mode that the pendant station be unplugged or placed in such a position that prevents simultaneous operation.*

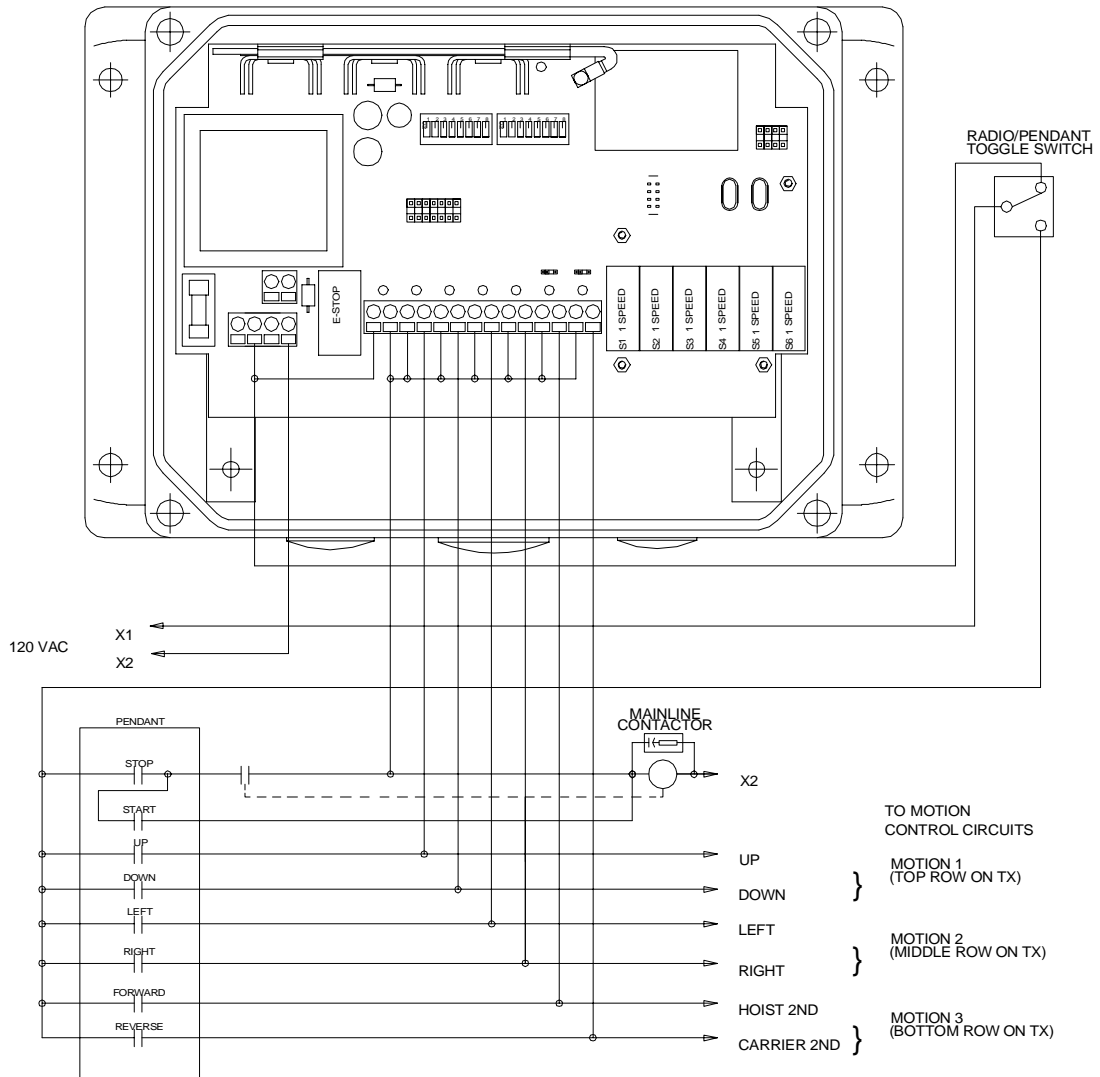

Figure 2.5: PulseStar JRT-306 Wiring Diagram with Pendant

## JRT-206-2

Refer to Figure 2.6: PulseStar JRT-206-2 Wiring Diagram to wire the PulseStar•jr. receiver to the crane controls.

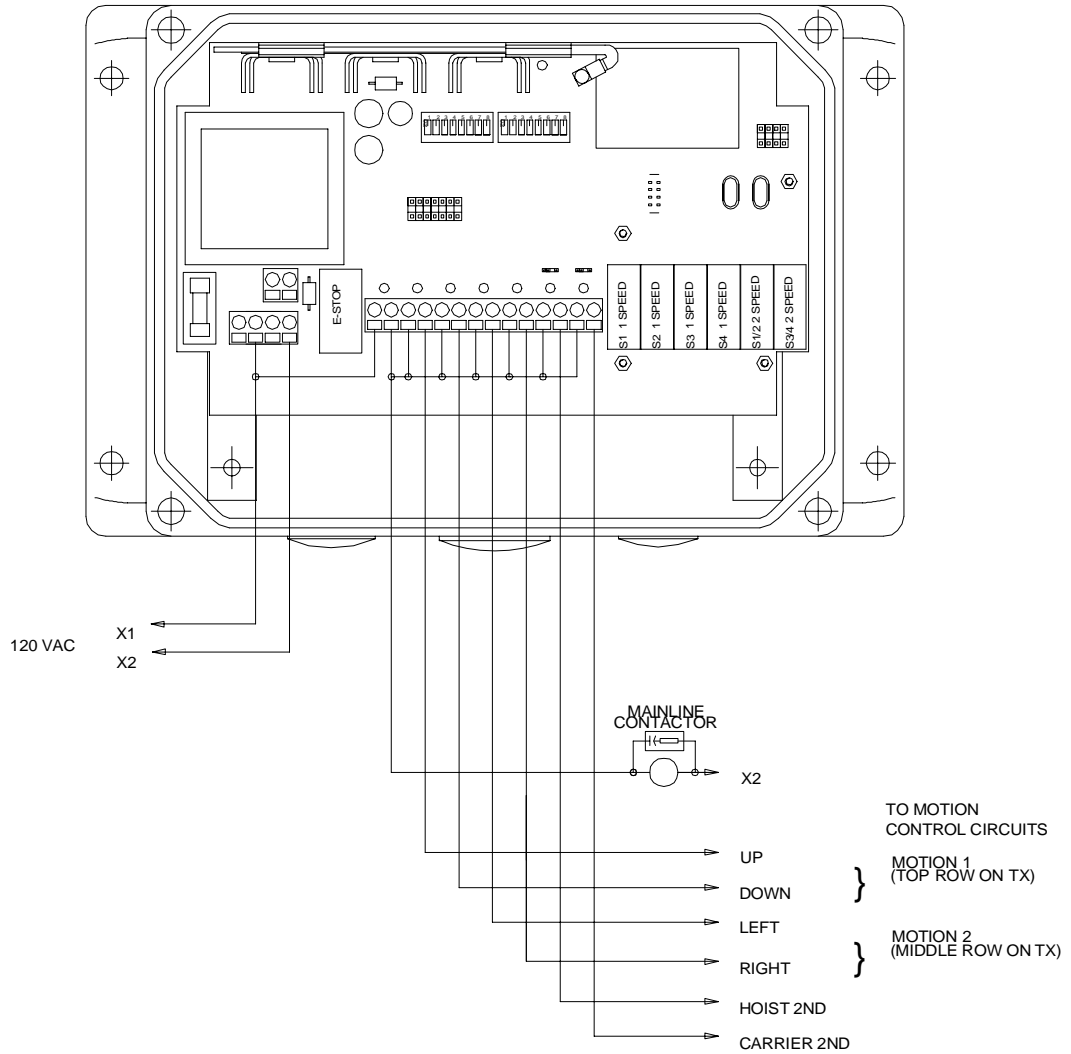

Figure 2.6: PulseStar JRT-206-2 Wiring Diagram

## JRT-206-2 with Pendant

Refer to Figure 2.7: PulseStar JRT-206-2 Wiring Diagram with Pendant Back-up to wire the PulseStar•jr. receiver to the crane controls when a back-up pendant is used.

**NOTE:** *The radio/pendant transfer switch shown does not provide total isolation between the radio control system and the pendant station. It is recommended that when the transfer switch is in “radio” mode that the pendant station be unplugged or placed in such a position that prevents simultaneous operation.*

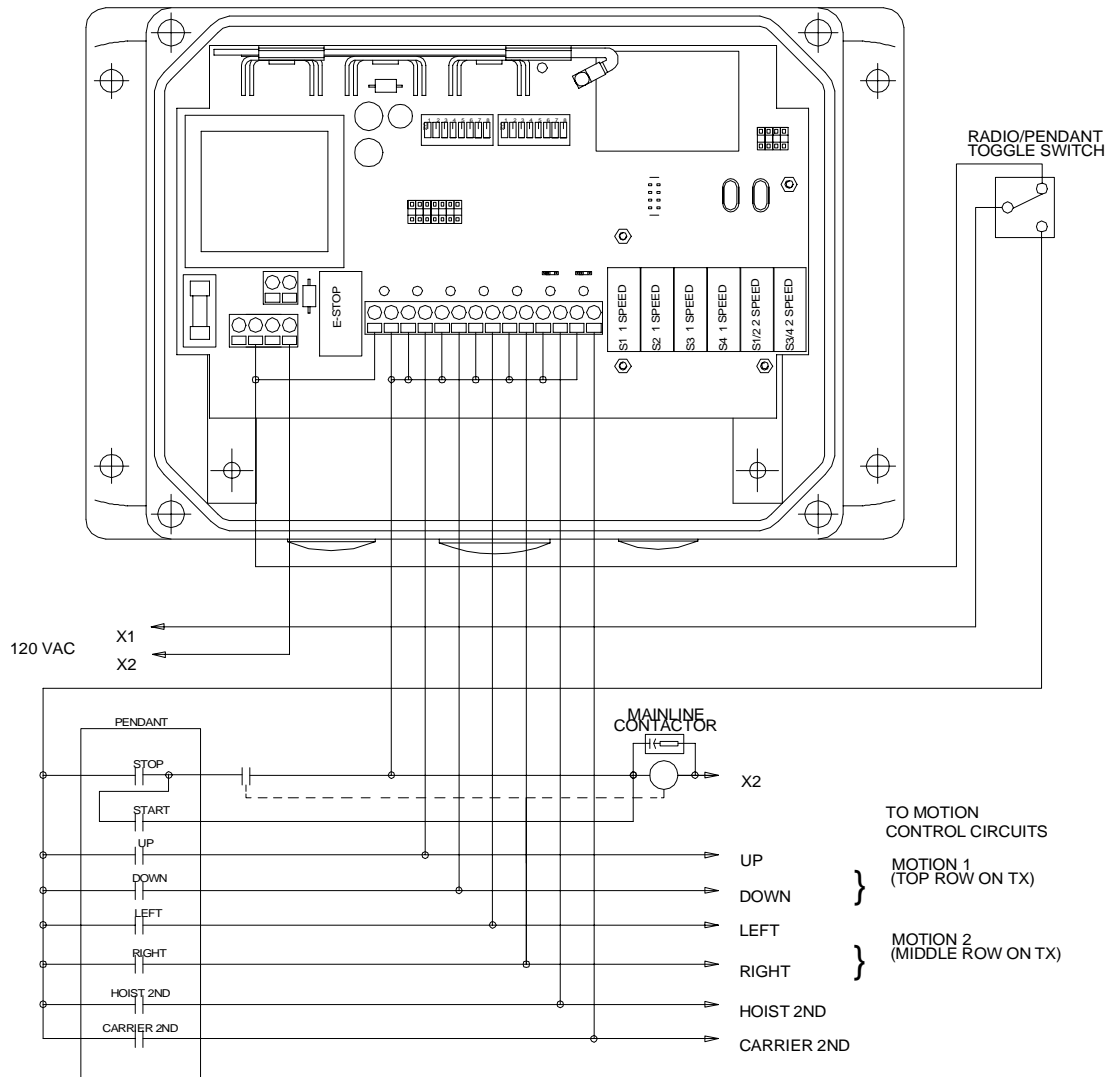

Figure 2.7: PulseStar JRT-206-2 Wiring Diagram with Pendant Back-up



## WARNING

- Only authorized personnel are permitted to perform the initial setup or service work. Use only Electromotive Systems parts.
- Do NOT touch any circuit components on the circuit board while the main AC or DC power is on.
- Do NOT change the address code settings in the receiver.
- Do NOT run control wires with power wires.
- Surge Suppressors must be used with all magnetic contactors that are controlled by the PulseStar•jr. system.

1. Refer to Figure 2.8: Input Power Connections to determine the appropriate power input blocks to use.
  - 12–24 VDC—use the 2-point terminal block.
  - 50/110/240 VAC—use the 4-point terminal block.
2. Run the power and control wires through the plug holes of the receiver enclosure.

**NOTE:** *Ensure that the receiver signal wires and the high voltage power wires cross at 90° angles. Never combine high voltage power and control wires in the same cable run.*
3. Remove the appropriate incoming power terminal block from the receiver Printed Circuit Board.
4. Connect incoming power to either the 2 point or 4 point terminal block as shown in Figure 2.8: Input Power Connections per customer requirement.

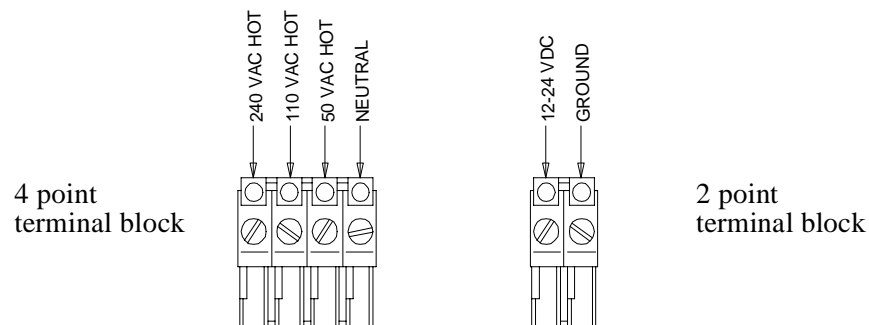

Figure 2.8: Input Power Connections

5. Connect the output wires as shown on the appropriate wiring diagrams previously shown.
6. Snap the terminal blocks to the terminals on the receiver circuit board.
7. Reinsert the cover of the receiver enclosure and tighten the four screws.
8. Install Resistor-Capacitor (RC) type surge suppressors (not MOV-type) across the coils of any magnetic contactors being controlled by the receiver.

**NOTE:** *Surge suppression is required on all magnetic contactors controlled by the receiver. Uncommanded crane motion and/or serious component damage may occur if surge suppressors are not used.*

## Connecting a Standard External Antenna

In some cases, such as when the receiver is inside a panel enclosure, you may need to connect an external antenna to the PulseStar•jr. receiver instead of using the internal antenna. Mount the standard external antenna on a metal surface with the same ground as the receiver circuit board. Make sure that the antenna is not surrounded by metal or other conductive materials. For best reception, the antenna should be pointing upward.

**NOTE:** *Failure to properly install the antenna will result in intermittent operation.*

1. Drill a  $\frac{9}{16}$  inch hole through the enclosure.
2. Insert the connector base through the hole so that the antenna side is on the outside, and the base is seated firmly against the enclosure surface. Remove any burrs from the antenna mounting hole and scrape away any paint which may prohibit the antenna base from making ground contact with the enclosure.
3. Assemble the antenna according to Figure 2.9: Standard External Antenna.

1. Antenna Pole
2. Enclosure
3. Antenna Base
4. Antenna Cable

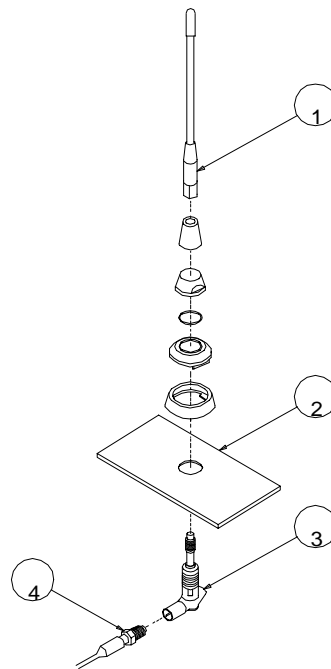

**Figure 2.9: Standard External Antenna**

4. Screw the antenna pole onto the antenna base.
5. Remove the internal antenna mounted in the PulseStar•jr. receiver by disconnecting it from the antenna connector on the receiver printed circuit board.
6. Connect the antenna cable connector to the antenna connector on the PulseStar•jr. printed circuit board.
7. Bundle any excess antenna cable by looping the cable, then flatten the cable loop and tighten both ends of the flattened cable with tie wraps or equivalent.

**NOTE:** *Never run the antenna cable with power or control wiring. Doing so will result in intermittent operation.*

## Connecting a Gain Flex Antenna

Some applications require the use of a gain flex antenna. The gain flex antenna can extend the operating range of the PulseStar•jr. system up to 300 meters (1000 feet). It is also used with intrinsically safe applications, and applications where a standard antenna is too difficult to mount. Make sure that there are no metallic or other conductive materials within 2 meters (6 feet) radius of the gain flex antenna. These objects will interfere with the reception of the gain flex antenna, and will result in intermittent crane operation. For best reception, the antenna should be pointing upward.

**NOTE:** *Failure to properly install the antenna will result in intermittent operation.*

Refer to Figure 2.10: Gain Flex Antenna when installing the gain flex antenna.

1. Affix the antenna base of the gain flex antenna to a mounting surface by using the two tie wraps included with the antenna kit. For best reception the antenna base should be mounted vertically with the antenna base pointing upward.

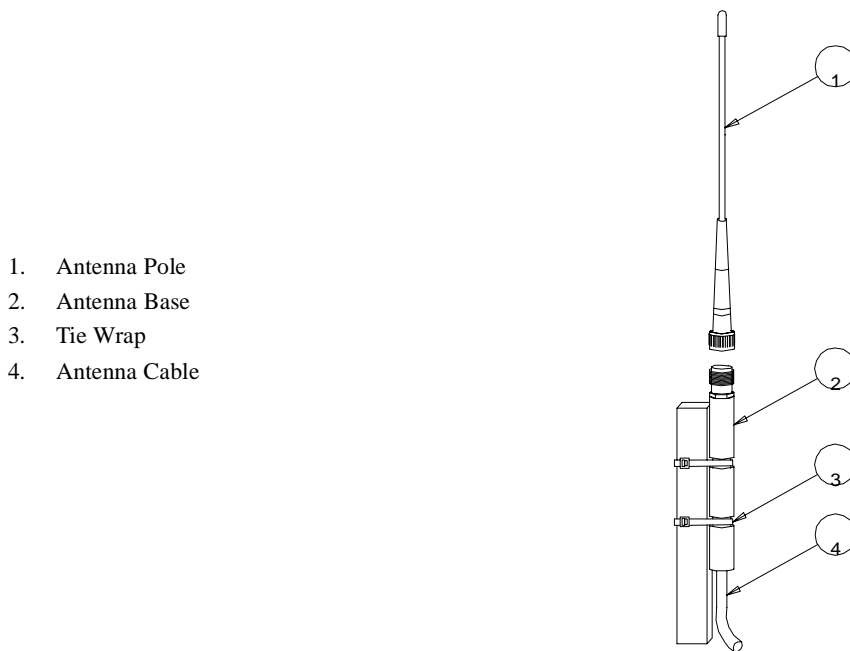

**Figure 2.10: Gain Flex Antenna**

2. Screw the gain flex antenna pole onto the antenna base.
3. Remove the internal antenna mounted in the PulseStar•jr. receiver by disconnecting it from the antenna connector on the receiver printed circuit board.
4. Connect the antenna cable connector to the antenna connector on the PulseStar•jr. printed circuit board.
5. Bundle any excess antenna cable by looping the cable, then flatten the cable loop and tighten both ends of the flattened cable with tie wraps or equivalent.

**NOTE:** *Never run the antenna cable with power or control wiring. Doing so will result in intermittent operation.*

# Start-up and Test Procedures



## WARNING

- Only authorized personnel are permitted to perform testing or service work.
- Make sure the crane is clear of any obstructions, and there is no load on the hook.
- Serious injury or component damage can occur if the PulseStar•jr. system is not properly installed and tested.

## Pre-operation Check List

Before you begin operating the PulseStar•jr. system to control your overhead crane, confirm the following check list to ensure that your system is working safely and correctly.

- There is a fully-charged battery in the transmitter.
- The second battery is in the charger being charged at all times. Ensure that the battery charger is plugged into a power source that is not turned off at night with the crane.
- The **Active E-STOP** button on the transmitter is pushed in (activated).
- The push-buttons are not depressed.

## Testing The Receiver

As you perform the following start-up test, place yourself in front of the PulseStar•jr. receiver with the cover off so that you can clearly see each LED and connection. Refer to Figure 2.11 : PulseStar JRX-6 Receiver Test Layout for LED and component locations.

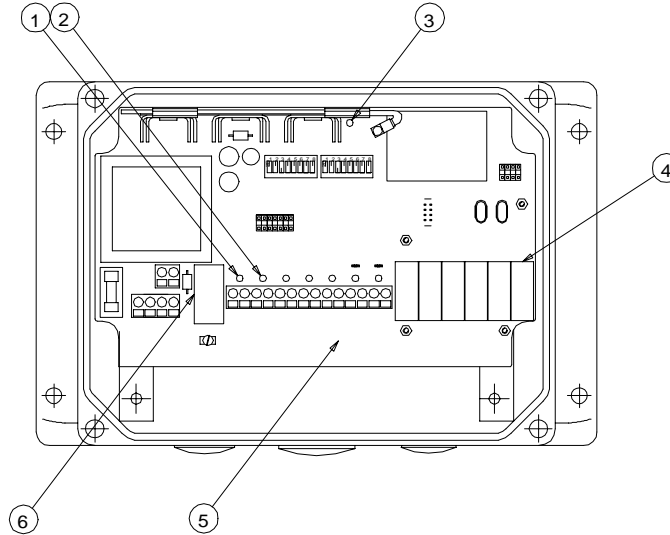

*Figure 2.11: PulseStar JRX-6 Receiver Test Layout*

- |                      |   |
|----------------------|---|
| 1. Active E-STOP LED | 4. Normally Open Motion Output Relay (1 of 6) |
| 2. Motion Relay LED  | 5. Receiver Printed Circuit Board             |
| 3. Telegram LED      | 6. Active E-STOP Relay                        |

1. Turn on the power to the receiver. The Telegram LED should flash once to indicate that the microprocessor is functioning properly.
2. Insert the key into the transmitter key switch and turn to the ON position. The transmitter Power LED should flash red indicating the start of a self-test. This self-test checks for the following.
  - The software is functioning properly.
  - The motion push-buttons are not pressed down.
3. After the diagnostic test the following should occur.
  - The Power LED should flash green.
  - The Telegram LED should flash on the Receiver Printed Circuit Board to indicate that the receiver is detecting a valid signal from the transmitter.
4. Pull out the **Active E-STOP** push-button. The following should occur.
  - The **Active E-STOP** LED on the Receiver Printed Circuit Board should turn on.
5. Test the **Active E-STOP** function by pushing in the **Active E-STOP** push-button on the transmitter. The following should occur.
  - The **Active E-STOP** LED on the Receiver Printed Circuit Board turns off.

6. Pull the **Active E-STOP** push-button out. Activate the motion push-buttons to test the crane functions. Confirm that the crane moves appropriately and that the LEDs corresponding to the motion relays turn on.
7. Push in the **Active E-STOP** push-button and turn the key switch to OFF. The following should occur.
  - The **Active E-STOP** LED on the Receiver Printed Circuit Board turns off.
  - The Telegram LED on the Receiver Printed Circuit Board turn off.
8. If all transmitter and receiver functions work properly, the system is ready for use.

**NOTE:** *If you experienced any problems during this test refer to Chapter 4 Troubleshooting PulseStar•jr. for help, or call Electromotive Systems.*

## Changing the Frequency Channel of the Receiver

### Standard RF Module

The PulseStar•jr. receiver is capable of receiving one of 16 discrete frequency channels. The frequency channel of the transmitter and receiver are set by Electromotive Systems prior to shipment. Should interferences occur on a particular frequency channel it may be necessary to change the frequency channel of the receiver and transmitter.

**NOTE:** *Do not change the receiver address code under any circumstances. Contact Electromotive Systems before making any frequency channel changes.*



#### WARNING

- Do NOT change the address code or frequency channel of the original transmitter that came with your PulseStar•jr. system without first contacting Electromotive Systems.
- Do NOT change the address code settings in the PulseStar•jr. receiver.
- Do NOT operate two transmitters set with the same frequency channel and address codes as the receiver at the same time.

The PulseStar•jr. transmitter and receiver operate over the 400—470 MHz frequency range (70-cm band). There are 16 possible frequencies and 16 corresponding channels available. Figure 2.12 : Receiver Frequency Channel Diagram shows each channel, its respective frequency, and the position of the four jumpers according to the diagram for the frequency channel you are setting.

### Frequency Channel Considerations

If there are multiple PulseStar radio remote control systems in your facility care should be taken in selecting frequency channels that will operate each system. Although PulseStar systems use a narrow band synthesized carrier frequency, residual or ‘side band’ energy from one system can interfere with other systems if they are in close proximity. Using the following guidelines will ensure that you will have trouble-free operation of all your PulseStar systems:

- Select frequency channels that are as far apart from one another as possible. Example: If you have two PulseStar remote radio controls, use frequency channel 0 and frequency channel 15.
- If PulseStar systems are within 50 feet of one another, each system’s frequency channel should be set a minimum of three channels apart from one another.
- If PulseStar systems are within 200 feet of one another, each system’s frequency channel should be set a minimum of two channels apart from one another.

**NOTE:** *If you are unsure about your application, or are experiencing periodic crane control drop-outs contact Electromotive Systems for assistance.*

## Setting the Frequency Channel

1. Remove the receiver cover.
2. Reference Figure 2.12: Receiver Frequency Channel Diagram to locate the Frequency Channel Jumper Block inside the receiver.
3. Set the frequency channel jumpers according Figure 2.12: Receiver Frequency Channel Diagram for the frequency channel you are setting for the receiver. A black box indicates that a jumper should be present in that position. A white box indicates there should be no jumper present in that position.
4. When finished, replace the receiver cover and tighten the four screws.

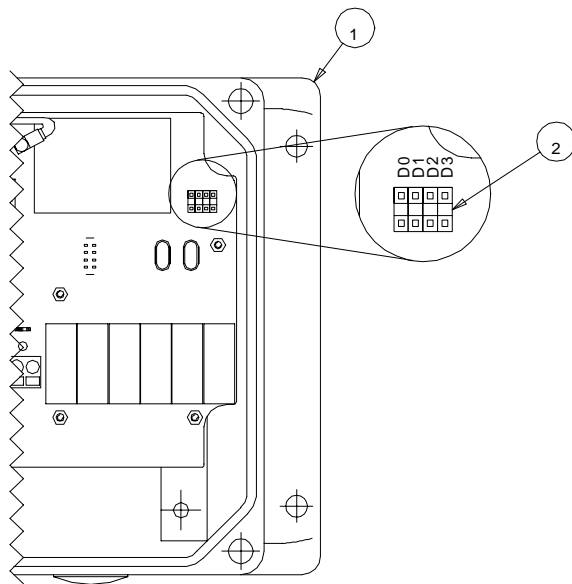

Channel	D0	D1	D2	D3	Frequency
0	■	■	■	■	458.800 MHz
1	□	■	■	■	458.825 MHz
2	■	□	■	■	458.850 MHz
3	□	□	■	■	458.875 MHz
4	■	■	□	■	458.900 MHz
5	□	■	□	■	458.925 MHz
6	■	□	□	■	458.950 MHz
7	□	□	□	■	458.975 MHz
8	■	■	■	□	459.000 MHz
9	□	■	■	□	459.025 MHz
10	■	□	■	□	459.050 MHz
11	□	□	■	□	459.075 MHz
12	■	■	□	□	459.100 MHz
13	□	■	□	□	459.125 MHz
14	■	□	□	□	459.150 MHz
15	□	□	□	□	459.175 MHz

■ Jumper is present

□ Jumper is not present

*Figure 2.12: Receiver Frequency Channel Diagram*

1. Enclosure
2. Frequency Channel Jumper Block

## Relay Latching Option

The fifth and sixth motion relays inside the receiver can be configured to latch. The factory setting for these relays is **momentary**. If the motion relay is set to **momentary**, the function controlled by that relay is activated only while the operator holds down the transmitter push-button. As soon as the push-button is released, the function stops.

If the motion relay is set to **latching**, the function controlled by that relay is activated when the transmitter push-button is depressed, and continues to be activated when the transmitter push-button is released. When the transmitter push-button is pressed a second time and released, the function stops.

If the motion control relay is set to **latching** and the relay is activated, the relay will remain activated even if the transmitter is turned off. To deactivate the motion control relay when the transmitter is turned off, disconnect the power supply to the receiver. The motion control relay will then return to the normally open state, and the function will stop.

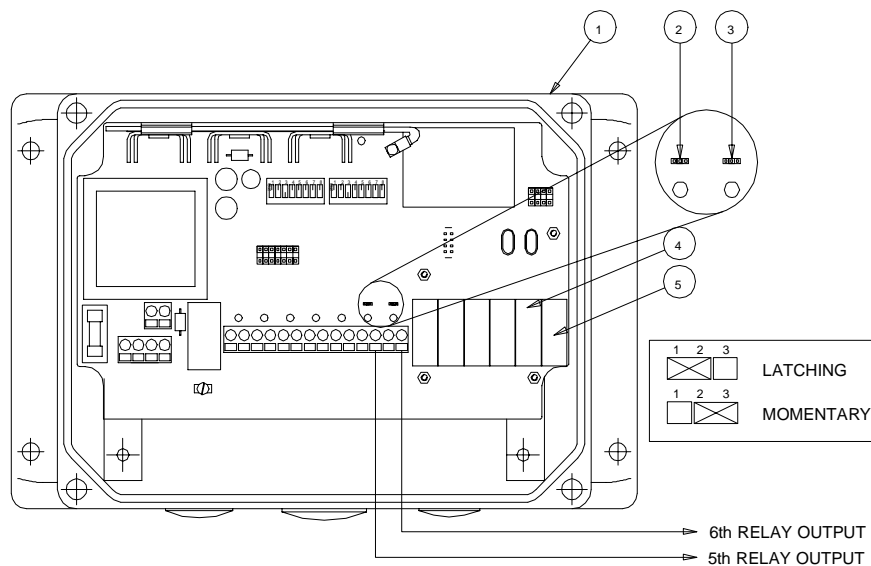

*Figure 2.13: Changing the Latching Function*

1. Receiver
2. Latching Function Jumper Block (Fifth Relay)
3. Latching Function Jumper Block (Sixth Relay)
4. Fifth Motion Control Relay
5. Sixth Motion Control Relay

### Setting the Relay Latching Option

1. Remove the receiver cover.
2. Reference Figure 2.13: Changing the Latching Function to locate the Latching Function Jumper Blocks inside the receiver. For momentary control place the jumper on pins 2 and 3 (factory setting). For latching control place the jumper on pins 1 and 2.
3. When finished, replace the receiver cover and tighten the four screws.

*c h a p t e r* **3**

---

**The PulseStar•jr.  
Transmitter**

# Overview

This chapter tells you how to configure and use the PulseStar•jr. transmitter. This manual will cover the basic features of the transmitter, as well as some of the more common options. For a complete description of how your PulseStar•jr. system functions contact Electromotive Systems.

Once you've installed, wired, and tested the PulseStar•jr. system, you are ready to use it. This chapter covers the following information.

- PulseStar•jr. Transmitter.
- Transmitter Setup.
- Start-up and Operation.
- Transmitter Options.
- Battery and Charger Information.

# PulseStar•jr. Transmitter

The JRT-5 transmitter is a hand-held radio control device with push-buttons used to control crane motions. The JRT-5 transmitter can control up to three crane motions with single speed control, or two motion with two speed control.

**NOTE:** The Start/Horn push-button is not used with JRT-206, JRT-206-2 or JRT-306 systems.

## JRT-5 Transmitter Components

The JRT-5 transmitter has the following components. Refer to Figure 3.1: JRT Transmitter Layout and to identify parts of the JRT transmitter.

1. Key Switch
2. Key Cap
3. Right Side Bezel and Membrane
4. START/HORN Push-button (not used)
5. Housing
6. Battery
7. Motion Push-button
8. Power LED
9. Top Bezel with Membrane
10. Active E-STOP Push-button

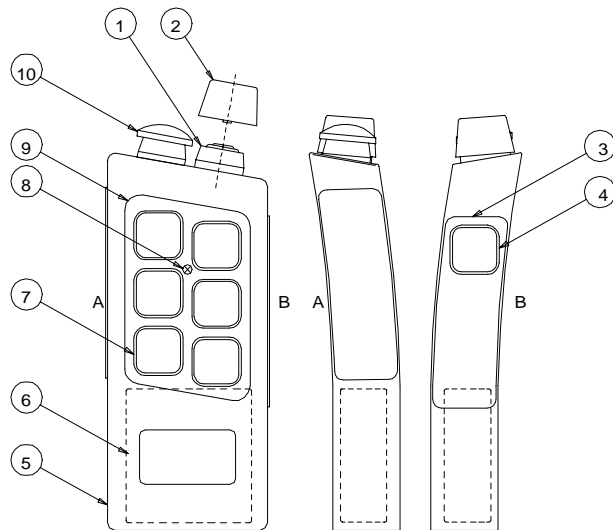

Figure 3.1: JRT Transmitter Layout

1. Key Switch
2. Key Cap
3. Active E-STOP Push-button
4. JRT Coder Board
5. Active E-STOP Push-button Contact Element
6. Frequency Channel Jumper Block
7. RF Module
8. Battery
9. Housing
10. Fuse
11. Internal Antenna
12. Address Code Switch Block
13. Key Switch Contact Element

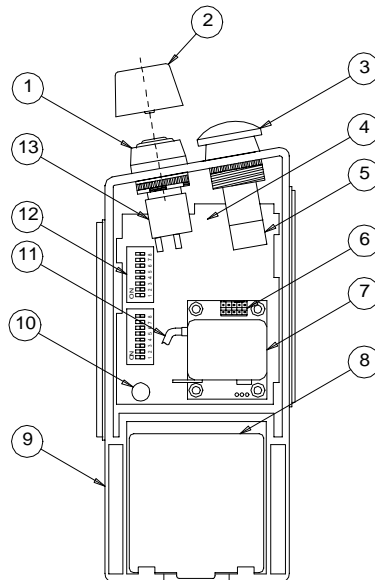

Figure 3.2: JRT Transmitter Layout Backside

## JRT-5 Transmitter Functions

The following describes the basic functionality of the JRT transmitter. Please reference Figure 3.1: JRT Transmitter Layout for the location of these functions.

**Active E-STOP Push-button.** Pressing the **Active E-STOP** push-button will place the receiver in **Safe Mode**. The **Active E-STOP** push-button must be pulled out for the transmitter to control the crane motions.

**NOTE:** *The Active E-STOP push-button is for emergency situations only. Do NOT use it as an OFF switch. Use the key switch to turn the transmitter on and off.*

**Power LED.** As soon as the JRT transmitter is turned on, this LED will emit a flashing red light. The transmitter performs a self-test to check the JRT software. If it passes, the LED changes to flashing green and continues flashing green until the transmitter is turned off. This LED changes to flashing red when the battery is low.

**Key Switch.** The key switch turns the transmitter on and off. It only works with the key cap inserted, and the key cap can only be removed while in the OFF position.

**Motion Push-buttons.** These push-buttons control the various crane motions and are labeled accordingly.

# Transmitter Setup

This section covers how to set up a PulseStar•jr. transmitter.

## Placing the Push-button Labels

If your new, spare or replacement JRT transmitter came with push-button legends that you need to insert, refer to Figure 3.3: JRT Transmitter Label Insertion and the following instructions.

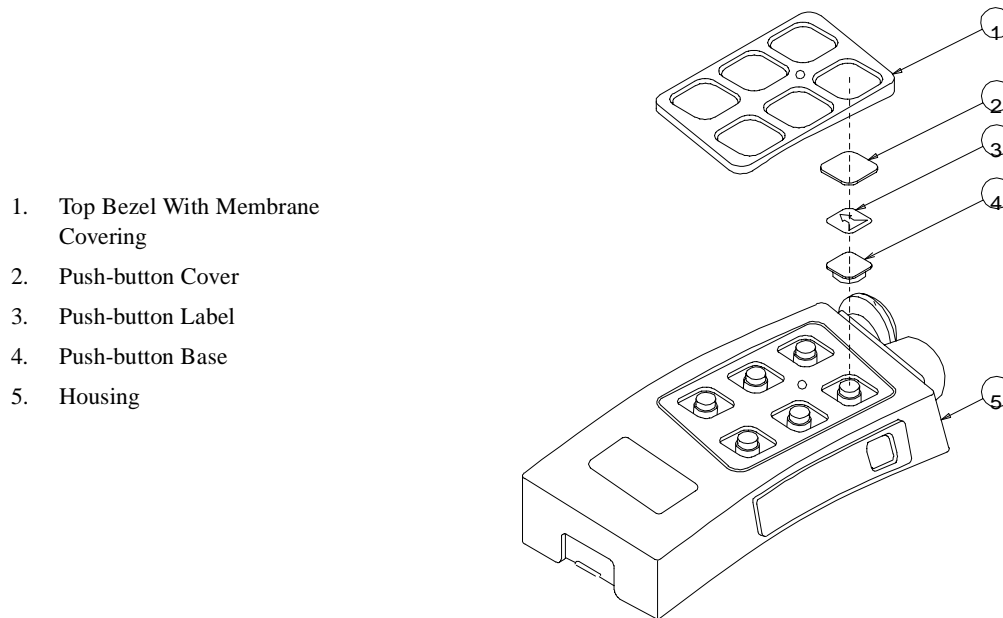

1. Top Bezel With Membrane Covering
2. Push-button Cover
3. Push-button Label
4. Push-button Base
5. Housing

*Figure 3.3: JRT Transmitter Label Insertion*

1. Unsnap the push-button cover from the push-button base. Remove the push-button label and replace it with the new label. Place the label in the push-button cover face down so that when you turn the push-button over, the push-button label is visible.
2. Snap the push-button base into the cover. Repeat steps 1 and 2 for each push-button label you are replacing.
3. Assemble the push-buttons on the transmitter according to the layout for your application.
4. Ensure that the transmitter housing is free of dirt, oil and other contaminants or the bezel with membrane covering won't stick. Use rubbing alcohol to clean any dirt or oils which may be present.
5. Once you are satisfied with the push-button layout, remove the adhesive strip on the back of the bezel with membrane covering and line it up on the enclosure. Press the bezel firmly into place.

**NOTE:** *DO NOT use any glues or adhesives to affix the bezel with membrane covering to the transmitter housing. Doing this can permanently damage the transmitter, and will void the warranty.*

## Transmitter Address Code and Frequency Channel

This section explains how to set the address code and frequency channel of the PulseStar•jr. transmitter. The PulseStar•jr. address code and frequency channel are configured at the factory. This should be done **ONLY** if you are setting up a spare or replacement transmitter, or directed to do so by Electromotive Systems.



### WARNING

- Do NOT change the address code or frequency channel of the original PulseStar•jr. transmitter that came with your PulseStar•jr. system without first contacting Electromotive Systems.
- Do NOT change the address code settings in the receiver.
- Do NOT operate two transmitters set with the same frequency channel and address code as the receiver at the same time.

### Serial Nameplate

The transmitter serial nameplate is located on one of the side walls of the PulseStar•jr. transmitter battery cavity. The serial nameplate contains the Electromotive Systems job number, the address code used by the system, and the frequency channel used by the system. **The Electromotive Systems job number is important if you ever need to call Electromotive Systems for service.** Please have this information available when contacting Electromotive Systems.

	Job # 2 0 0 0
<b>PulseStar</b>	Addr. 1 9 3 2 7
	Freq. 5

*Figure 3.4: Serial Nameplate*

## Setting the Address Code and Frequency Channel of a Transmitter:



### CAUTION

*Before working on the transmitter, remove the battery.*

Before setting the address code and frequency channel of the transmitter, ensure you first know the address code and frequency channel of the receiver it is going to control. This information can be found by locating the serial nameplate on the PulseStar•jr. receiver. Refer to the Serial Nameplate section in chapter 2 for the location of the receiver serial nameplate.

1. Make sure the transmitter is off. Remove the key to be sure.
2. Remove the battery from the transmitter, refer to Battery and Charger Information later in this chapter.
3. Access the inside of the PulseStar•jr. transmitter by removing the screws that fastens the back plate to the housing and remove back plate.
4. Locate the two blocks of address code DIP switches on the transmitter coder board, and the frequency channel jumper block on the RF module inside the PulseStar•jr. transmitter.

### Determining the Address Code

Refer to Figure 3.6: JRT Coder Board Layout for the location of the address code dip switches.

The address code is a 16 bit binary number which is assigned to each PulseStar system. This code ensures that no other PulseStar system or other radio controlled device can accidentally operate the crane. The address code number on the serial nameplate is a decimal equivalent to the binary code assigned to the system. To determine the binary code of your PulseStar system you can do one of the following:

- Using a calculator with decimal to binary conversion, enter the decimal address code number from the serial nameplate on the receiver. Then convert this number to it's binary equivalent.
- Record the 16 address code switch positions inside the receiver. All switches are either 'on' or 'off'. Always read the switches with the numbering and lettering right side up, from left to right, and with switch number 1.1 being on the left.
- Consult Electromotive Systems for information concerning your address code.
- Referencing Figure 3.5: Address Switch Chart use the following formula.

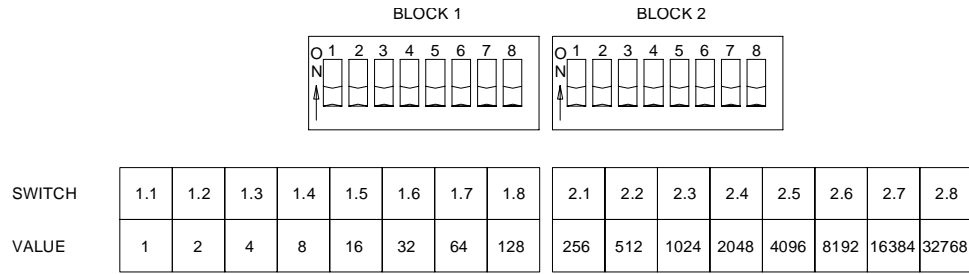

Figure 3.5: Address Switch Chart

1. Write down the transmitter address code.
2. Using the above chart find the largest value that can be subtracted from the address code.
3. Subtract the value from the code.
4. Next to the value write down the corresponding switch number.
5. Repeat steps 2 through 4 until you get a final value of zero.
6. All switches that are listed next to values used should be placed in the on position. All switches that are not listed are to be placed in the off position.

**EXAMPLE:**

The address code is 32518.

$\begin{array}{r} 32518 \\ - 16384 \\ \hline 16134 \end{array}$	Switch 2.7 On	$\begin{array}{r} 774 \\ - 512 \\ \hline 262 \end{array}$	Switch 2.2 On
$\begin{array}{r} 16134 \\ - 8192 \\ \hline 7942 \end{array}$	Switch 2.6 On	$\begin{array}{r} 262 \\ - 256 \\ \hline 6 \end{array}$	Switch 2.1 On
$\begin{array}{r} 7942 \\ - 4096 \\ \hline 3846 \end{array}$	Switch 2.5 On	$\begin{array}{r} 6 \\ - 4 \\ \hline 2 \end{array}$	Switch 1.3 On
$\begin{array}{r} 3846 \\ - 2048 \\ \hline 1798 \end{array}$	Switch 2.4 On	$\begin{array}{r} 2 \\ - 2 \\ \hline 0 \end{array}$	Switch 1.2 On
$\begin{array}{r} 1798 \\ - 1024 \\ \hline 774 \end{array}$	Switch 2.3 On		

Once you have the correct address code information you can configure the transmitter to work with the existing receiver.

## Setting the Address Code

Reference Figure 3.6: JRT Coder Board Layout to change the address code.



### WARNING

- Do NOT change the address code or frequency channel of the original PulseStar•jr. transmitter that came with your PulseStar•jr. system without first contacting Electromotive Systems.
- Do NOT change the address code settings in the receiver.
- Do NOT operate two transmitters set with the same frequency channel and address code as the receiver at the same time.

1. Position the address code switches so that the numbering and lettering is right side up.
2. Locate switch 1.1 on the left most block of the address code switches. This switch is the first bit of the binary address code.
3. Set each switch to either 'on' or 'off' according the binary address code information.
4. If you do not have to set the frequency channel you can now close the transmitter by placing the back plate in place and inserting the screws.

1. Switch 2.8
2. Address Code DIP Switches
3. Frequency Channel Jumper Block
4. RF Module
5. Fuse
6. Switch 1.1

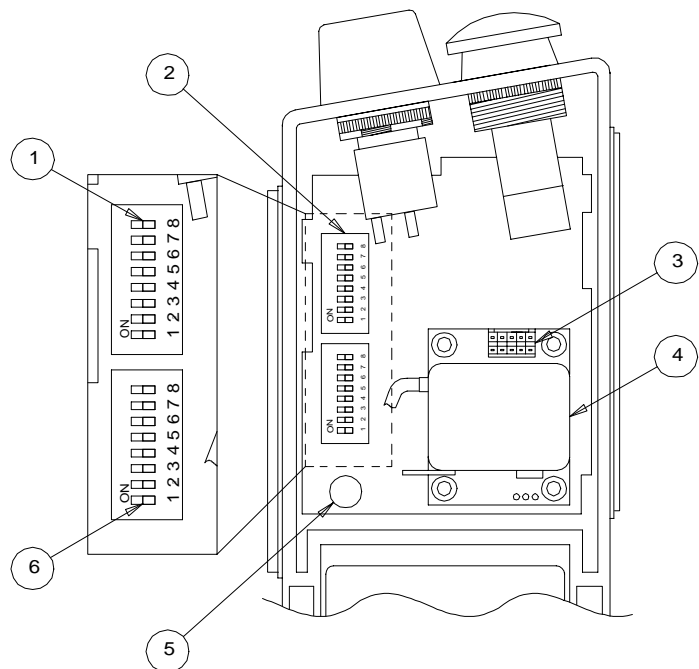
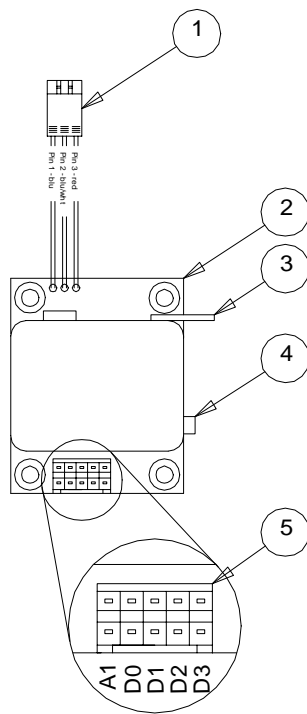

*Figure 3.6: JRT Coder Board Layout*

## Setting the Frequency Channel

The frequency channel of the transmitter must be set to the frequency channel of the receiver it is going to control. The transmitter and receiver operate over the 400–470 MHz frequency range (70-cm band). There are 16 possible frequency channels. Figure 3.7: Frequency Diagram shows the transmitter RF Module, and each channel, its respective frequency, and the position of the five jumpers.

1. Reference Figure 3.6: JRT Coder Board Layout to locate the RF Module inside the transmitter.
2. Locate the Frequency Channel Jumper Block on the RF Module. Position the transmitter so that the A1 jumper position is on your left-hand side.
3. Set the frequency jumpers according to the diagram for the desired frequency. A black box indicates that a jumper should be present in that position. A white box indicates there should be no jumper present in that position.
4. When finished, close the transmitter by placing the back plate in place and inserting the screws.



Channel	A1	D0	D1	D2	D3	Frequency
0	■	■	■	■	■	458.800 MHz
1	■	□	■	■	■	458.825 MHz
2	■	■	□	■	■	458.850 MHz
3	■	□	□	■	■	458.875 MHz
4	■	■	■	□	■	458.900 MHz
5	■	□	■	□	■	458.925 MHz
6	■	■	□	□	■	458.950 MHz
7	■	□	□	□	■	458.975 MHz
8	■	■	■	■	□	459.000 MHz
9	■	□	■	■	□	459.025 MHz
10	■	■	□	■	□	459.050 MHz
11	■	□	□	■	□	459.075 MHz
12	■	■	■	□	□	459.100 MHz
13	■	□	■	□	□	459.125 MHz
14	■	■	□	□	□	459.150 MHz
15	■	□	□	□	□	459.175 MHz

■ Jumper is present

□ Jumper is not present

*Figure 3.7: Frequency Diagram*

- |                     |                                   |
|---------------------|-----------------------------------|
| 1. TTL Connector    | 4. Antenna Connector              |
| 2. RF Module        | 5. Frequency Channel Jumper Block |
| 3. Ground Connector |                                   |

# Start-up and Operation

## Holding the Transmitter

Before using the PulseStar•jr. transmitter, refer to the following information on how to hold the PulseStar•jr. transmitter the correct way.



### WARNING

To make sure that you are oriented correctly in relation to the directional push-buttons. Hold the transmitter as shown.

Please refer to Figure 3.8: JRT Transmitter Orientation on how to properly hold the JRT transmitter.

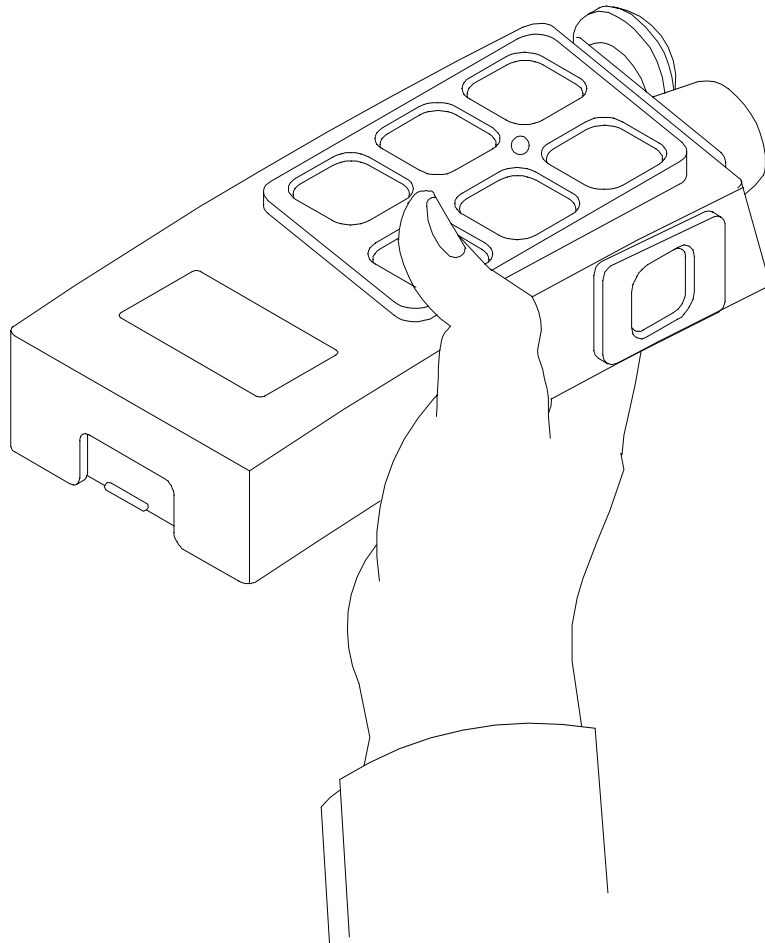

*Figure 3.8: JRT Transmitter Orientation*

## Start-up

Refer to Figure 3.1: JRT Transmitter Layout section for the location of the various functions on the PulseStar•jr. transmitter. To start the PulseStar•jr. transmitter:

1. Make sure that there is a charged battery in the transmitter.
2. Make sure the **Active E-STOP** push-button is pressed in (activated).
3. Make sure no motion push-buttons are depressed.
4. Insert the key into the key switch and turn to the ON position. The power LED flashes red to indicate power is on, and the transmitter is going through a self-check. If the transmitter passes the self-check, the power LED flashes green.
5. Pull out the **Active E-STOP** push-button to provide power to the mainline contactor.

The transmitter is now ready for use.

## Emergency Stop

For all emergency situations, push in the **Active E-STOP** push-button. To restart, pull out the **Active E-STOP** push-button.

When the PulseStar•jr. battery voltage drops below approximately 8 volts, the power LED on the transmitter will begin flashing red for about 30 seconds. At the end of the 30 second period, the transmitter will automatically shut itself off and places the receiver in **Ten Minute Time-out Mode**. This blocks all crane motion commands.

## Using the Motion Push-buttons

The JRT transmitter can control up to three crane motions. Each pair of push-buttons corresponds to one crane motion. The push-buttons are “interlocked,” which means that only one push-button in each horizontal row is operational at a time. In other words, if you press a push-button, the crane function corresponding to that push-button will be activated. If you then press the other push-button in the same row while still holding down the first push-button pressed, the receiver will ignore the crane motion corresponding to the second push-button pressed.

## Shutting Off the Transmitter

When you are finished using the transmitter, turn the key switch to Off. The receiver will go into the **Ten Minute Time-out Mode**. After the **Ten Minute Time-out Mode** expires the receiver will go into **Safe Mode** and the mainline contactor will drop out. Remove the key switch and take it with you to prevent unintended use.

# Transmitter Options

The following are some of the more common options which are available with the PulseStar•jr. transmitter. If you have any questions about the functionality of your PulseStar•jr. system contact Electromotive Systems.

## Spare Transmitter

Spare transmitters can be used in the event that the primary transmitter becomes lost or damaged. One transmitter is used as the main crane control and the other is designated as a spare. Only one transmitter is active at any given time.

***NOTE: If both transmitters are set to the same frequency and address, and both transmitters are turned on, the receiver will go into Safe Mode.***

# Battery and Charger Information

## Removing and Inserting the Battery From the Transmitter

To remove or insert the battery from the JRT transmitter, refer to Figure 3.9: JRT Transmitter Battery Removal.

**Removal:** Push the battery toward the spring-loaded contacts. Tilt the battery away from the housing until the battery pops out of the compartment.

**Insertion:** Place the battery in the battery cavity at an angle, with the end containing the gold plated contacts facing the spring-loaded contacts. Push battery into the battery cavity and against the spring loaded contacts until the battery can be placed flush against the battery cavity wall. The battery should now be securely positioned inside the battery cavity.

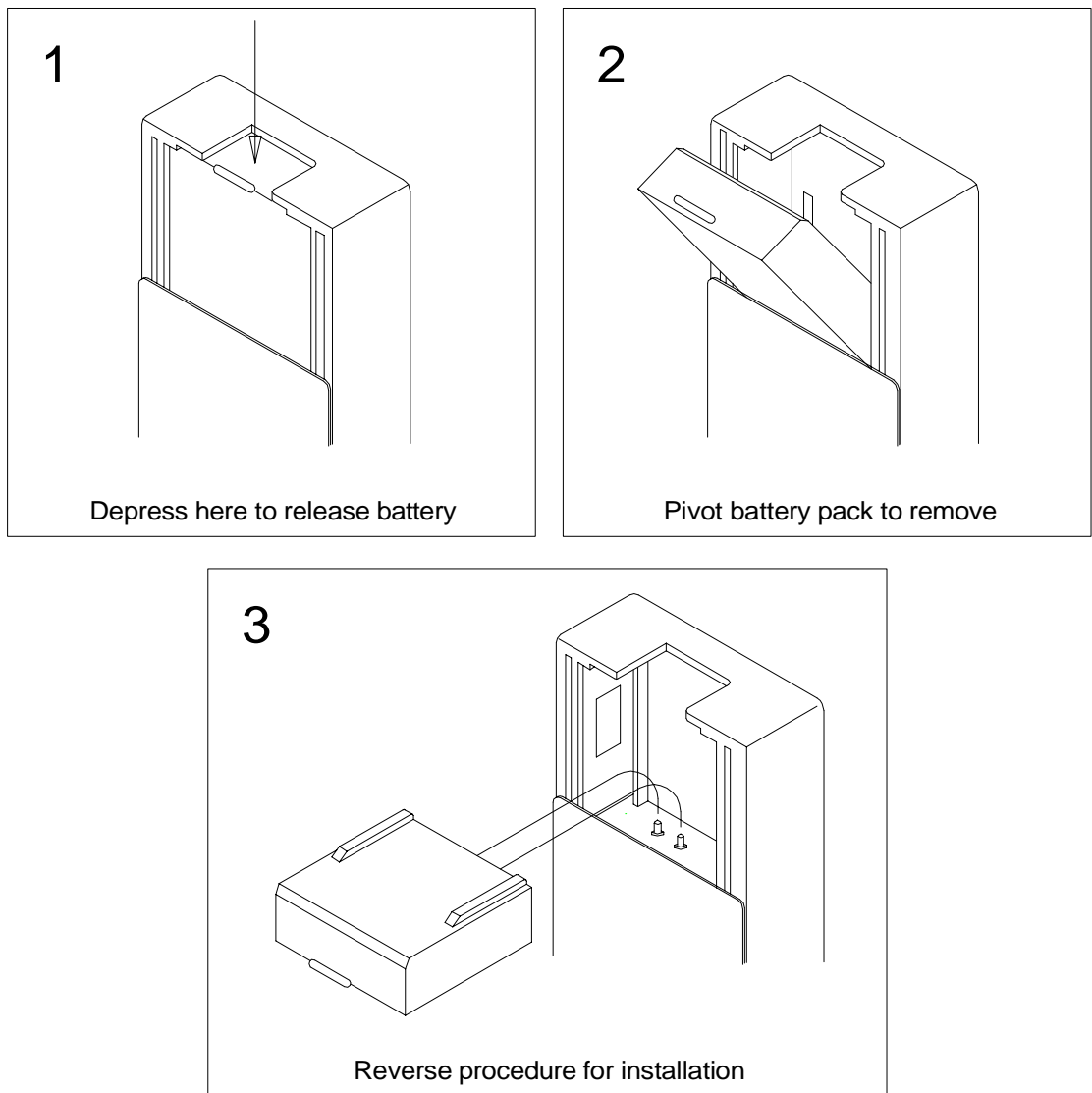

*Figure 3.9: JRT Transmitter Battery Removal*

## Charging the Battery

The PulseStar battery charger is designed for 115/230VAC and plugs into a regular wall outlet. Please refer to Figure 3.10: Battery Charger for JRT Transmitters for charger layout.

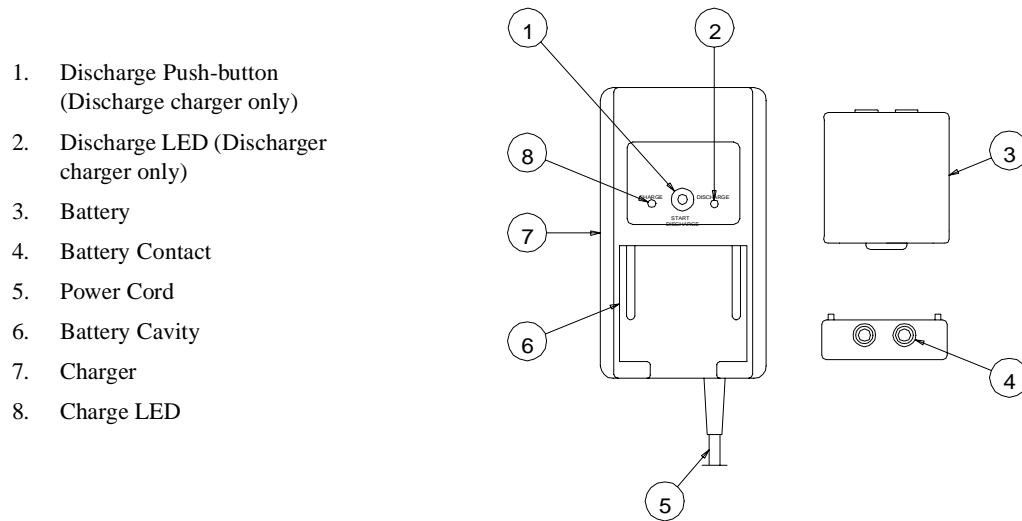

*Figure 3.10: Battery Charger for JRT Transmitters*

## Standard Charger

Insert the battery into the charger. The green charge LED emits a steady light to indicate that the battery is being charged.

The processor in the charger checks the capacity of the battery until the battery is fully charged. The maximum charging time is four hours. When the battery is fully charged, the green charge LED begins to flash. Leave the battery in the charger until needed to ensure it is fully-charged.

If the power supply to the charger is interrupted, or the battery is removed and then reinserted into the charger (before the battery was fully charged), the charger detects how much charge the battery has left and resumes the charging process.

## Discharge Charger

Insert the battery into the charger. The green charge LED emits a steady light to indicate that the battery is being charged. Press the red Discharge push-button. The green charge LED turns off, and the red discharge LED turns on. The battery will now fully discharge. Once the battery is fully discharged, the red discharge LED will turn off, and the green charge LED will turn on. The green charge LED emits a steady light to indicate that the battery is being charged.

The processor in the charger checks the capacity of the battery until the battery is fully charged. The maximum charging time is four hours. When the battery is fully charged, the green LED begins to flash. Leave the battery in the charger until needed to ensure it is fully-charged.

The following table summarizes battery information for JRT.

Charging Time	4 hours (from fully discharged)
Operation Time	7–10 hours continuous
Type	Nickel Metal Hydrite; 9.6 Volts, 750 milliampere hours
Maximum number of charges	Approximately 800 times

All charger and battery contacts are gold-plated to provide superior contact. Batteries and chargers are IP65-rated. The mechanical design of the battery case and the battery pocket ensures that each insertion and removal of the battery will clean the contacts. This is known as “self-cleaning” contacts.

## Memory Effect

To maximize the lifetime of your battery, **only charge completely discharged batteries** whenever possible. Charging a partially discharged battery may result in a memory effect in the battery, which reduces the number of times it can be effectively charged.

*c h a p t e r* **4**

---

**Troubleshooting  
PulseStar•jr.**

# Troubleshooting

## Introduction

This chapter covers what to do if the PulseStar•jr. does not seem to work properly. If you are unable to resolve the problem after using this section, contact Electromotive Systems immediately at 1-800-288-8178.



### WARNING

- Only authorized personnel are permitted to perform the initial setup or service work. Use only Electromotive Systems parts.
- Do NOT touch any circuit components on the circuit board while the main AC or DC power is on.
- Do NOT change the address code settings in the receiver.

## Common Problems

The following are common problems associated with using the PulseStar•jr. system, and their possible solutions. For help in diagnosing problems in the receiver, refer to the drawing in the Start-up and Test Procedures section in chapter 2 that shows the location of each diagnostic LED.

**Problem: The transmitter is turned on, but it does not broadcast (Power LED not flashing).**

### Possible Solution(s):

- Battery is dead. Replace with fully charged battery.
- Fuse located on coder board is blown. Check fuse and replace if blown.
- Key switch is broken. Check wiring to the key switch contact element. Replace key switch wiring or contact element.
- The coder board has failed. Contact Electromotive Systems.

**Problem: The transmitter is broadcasting, but all crane motions are not working.**

### Possible Solution(s):

- The Active E-STOP push-button is activated (pushed in). Pull out the Active E-STOP push-button.
- Transmitter is out of range (328 feet typical). Bring the transmitter back into range.
- A crane motion function was not 'off' when transmitter was turned on. Make sure all push-buttons are in the off position. Cycle transmitter power (turn off and then on).
- Incoming power to receiver is off. Turn on power to receiver.
- Fuse is blown in receiver. Check and replace any blown fuses.

- Receiver is set for different frequency channel. If green Telegram LED located on the receiver printed circuit board is not flashing, check that the receiver frequency channel matches that of the transmitter.

**NOTE:** *Always match the transmitter frequency channel to the receiver. Never change the receiver frequency channel without consulting Electromotive Systems first.*

- Receiver is set for different address code. Check to make sure the address code on the receiver printed circuit board matches the address code of the transmitter.

**NOTE:** *Always match the transmitter address code to the receiver. Never change the receiver address code without consulting Electromotive Systems first.*

- **Active E-STOP** failure in transmitter. Check **Active E-STOP** push-button for damage. Check wiring to **Active E-STOP** push-button contact element for broken or disconnected wire(s). Replace broken wire(s) or **Active E-STOP** push-button.

**Problem: All crane motions work intermittently.**

**Possible Solution(s):**

- Antenna in receiver is loose or has fallen off. Secure or replace antenna.
- External antenna (when used) is loose, poorly grounded, or receiving interference. See Connecting a Standard External Antenna section in Chapter 2.
- Surge suppressors are not installed on contactors being controlled by the receiver. Make sure all contactors being controlled by the receiver have surge suppressors installed.
- Control wiring may be combined with power wiring. Make sure that all control wiring is separate from power wires.
- Another PulseStar transmitter may be interfering with the system. If another PulseStar system is located within 200 feet, the frequency channels must be at least 2 channels apart. If another PulseStar system is within 50 feet, the channels must be at least 3 channels apart. Contact Electromotive Systems for assistance.

**Problem: Some crane motions work intermittently.**

**Possible Solution(s):**

- Wiring may be loose to that crane motion. Check wiring from the receiver to the crane motion.
- Connector inside receiver has come loose. Check all terminal block connectors.
- Surge suppressors may not be installed on contactors controlling that crane motion. Make sure all contactors being controlled by the receiver have surge suppressors installed.
- Control wiring may be combined with power wiring. Make sure that all control wiring is separate from power wires.

## Questions to Ask

When reporting a problem to Electromotive Systems you may be asked several questions pertaining to the PulseStar•jr. system. Asking these questions to the person who reported the problem prior to calling Electromotive Systems will speed up the troubleshooting process.

### General

- Are there other PulseStar systems at or near the crane site?

### Transmitter

- Is the **Active E-STOP** push-button pulled out?
- Is the key switch in the ON position?
- Are the push-buttons in the off position?
- Is there a charged battery installed?
- Did you take the transmitter out of its operating range (328 feet)?

### Receiver

Open the cabinet enclosure where the receiver circuit board is installed and check the following. Refer to the drawing in the Start-up and Test Procedures section in chapter 2 that shows the location of each diagnostic LED.

- Is the Telegram LED flashing?
- Is the **Active E-STOP** LED on the receiver printed circuit board lit?
- Are the connections/screw terminals tight?
- Is the internal antenna securely connected?
- Is the external antenna assembly outside the enclosure securely connected?
- Are all incoming power supply and ground wires properly connected?
- Are the signal wires separated from the power wires?
- Are surge suppressors installed on all magnetic contactors being controlled by the receiver?

*a p p e n d i x* **A**

---

**Definitions and Abbreviations**

# Definitions and Abbreviations

## Definitions

The following terms are used throughout the *PulseStar•jr. Instruction Manual* and may be unfamiliar to some operators.

<b>Term</b>	<b>Definition</b>
analog	Proportional-stepless or infinite control
baud	The transmitting speed measured in bits per second
decoder	Converts a serial data message into parallel signals
double superheterodyne	A method to build an extremely narrow band receiver by converting the receiver frequency twice.
coder	Converts parallel signals into a serial data message
hamming distance	A measurement of data transmission safety. The amount of failures in the data stream which has to occur during the transmission in order to create a wrong signal. A low hamming distance means that the test is not very sensitive to data transmission errors and could be potentially unsafe. A high hamming distance means that the system is very sensitive and could potentially be unreliable due to potential noise interference.
latching	The auxiliary function will turn on when the operator presses option button once and releases it (PBT) or flips the spring return switch up (NVT, GLT, GRT). The auxiliary function will not turn off until the operator presses the option button a second time (PBT) or flips the spring return switch (NVT, GLT, GRT).
maintained	The auxiliary function will turn on when the operator flips the maintained switch to the appropriate position (NVT, GLT, GRT). The auxiliary function will turn off as soon as the operator flips the maintained switch to the off position (NVT, GLT, GRT).
momentary	The auxiliary function will turn on when the operator presses the option button and holds it down (PBT) or flips the spring-return switch and holds it up (NVT, GLT, GRT). The auxiliary function will turn off as soon as the operator releases the option button (PBT) or releases the spring-return switch (NVT, GLT, GRT).
synthesizer technology	Used to electronically generate a carrier frequency.

## Commonly Used Abbreviations

<b>Abbreviation</b>	<b>Meaning</b>
A/D	Analog to digital conversion
AK	Analog channel (German: Analog Kanal)
AMP	Ampere
AWG	American wire gauge
BPS	Bits per second
DK	Digital channel (German: Digital Kanal)
EMC	Electromagnetic compatibility
EMI	Electromagnetic immunity
EPROM	Electrical programmable read-only memory
FM	Frequency modulation
GND	Ground
HF	High frequency
KHz	Kilohertz
mAH	Milliamperere hours
mA	Milliamperere
msec	Millisecond
MHz	Megahertz
mW	Milliwatt
NiCd	Nickel cadmium
NiMH	Nickel Metal Hydrite
PLC	Programmable logic controller
PLL	Phased locked loop
PWM	Pulse width modulation
RF	Radio frequency (same as HF - high frequency)
RMS	Root mean squared
Rx	Receiver
RxD	Receiving data
SMD	Surface mount device
SMT	Surface mount technology
TTL	Transistor transistor logic
Tx	Transmitter
TxD	Transmitting data
Ub	Operating power
Uv	Microvolts
VAC	Volts (alternating current)
VDC	Volts (direct current)

*a p p e n d i x* **B**

---

**Specifications**

# Specifications

## System Specifications

<b>Specification</b>	<b>Setting</b>
Certification	TÜV and CE
Temperature range	-18°F to 158°F (-25°C to 70°C)
Operating range	330 feet (100 meters) typical
Humidity range	0-95% maximum non-condensing
Environment	IP66 Weatherproof Receiver; IP65 Weatherproof Transmitter
Modulation	Narrow band - FM
Frequency range	400 - 470 MHz (16 preset frequencies)
Bandwidth	12.5 kHz/25kHz
Frequency generation	Microprocessor controlled PLL Synthesizer
Microprocessor	Intel
Baud rate	4800 bps (approx. 55 msec response time)
Hamming distance	4
Security	16-bit addressing (more than 65,000 possibilities)

## JRT Specifications

<b>Specification</b>	<b>JRT-5</b>
Weight	Less than 1.5 lbs (including battery)
Physical size (LxWxH)	7.8" x 3.4" x 1.4" (19.8 cm x 8.6 cm x 3.6 cm)
HF output power	Maximum 10 mW
Deviation	±2kHz
Power supply	9.6-V Nickel Metal Hydrite rechargeable battery; 750 milliamp-hours
Operation time	7–10 hours continuous with one charge
Enclosure	IP65 Weatherproof (exceeds NEMA 12/13)
Protection	Key switch with cap
Antenna	Built-in
Functions	Emergency-stop button (push/pull) 3 crane motions 2 speeds, interlocked
Features	Sleep mode (10 minutes) Switch-ON protection Mechanical protection against accidental activation
Battery charger	115/220VAC (±20%) Charging time—4 hours Gold plated and self-cleaning contacts 2 batteries included

## Receiver Specifications

<b>Specification</b>	<b>JRX-6</b>
Weight	Approximately 3.6 lbs
Physical size (LxWxH)	9.70" x 6.30" x 3.66" (24.6 cm x 16 cm x 9.3 cm)
Operating power	50/110/240 VAC 50/60Hz (+/- 20%) or 12/24 VDC (+/- 50%)
Current	<100 mA
HF part	Double Superheterodyne
Sensitivity	0.4 microvolts (Root Mean Squared)
Safety	Self-monitoring emergency circuitry Fail-safe, spring-forced Emergency-stop relay Self-test during start-up and operation
Diagnostic	On-board diagnostic system with indicators for: RF communication, active outputs
Output	1 Emergency-Stop relay, 275 VAC 8 Amp/30 VDC 5 Amp 6 Motion relays - normally open, 275VAC 8 Amp/30 VDC 5 Amp
Antenna	Built-In (External Antenna Optional)

*a p p e n d i x* **C**

---

**StarService and Warranty**

# StarService Policy

This chapter includes information pertaining to on-call service, transmitter loaner and Repair program, and Receiver Replacement/Repair Program warranty. Before you install, troubleshoot, or service the radio control system, we highly recommend that you read this entire chapter. Doing this will help assure quick service response, minimize your on-site repair costs, and reduce crane downtime.

## On-Call Service

If you ever have a problem with your PulseStar•jr. system, call Electromotive Systems at 1-800-288-8178. Technical support is available 24 hours a day, seven days a week. If necessary, Electromotive Systems can arrange to have a service technician visit your site to evaluate the situation (normally at your expense.)

## Warranty

Every PulseStar product includes a two-year warranty from the date of shipment. The warranty is described in detail later in this chapter.

## Transmitter Loaner, Replacement & Repair Program

The PulseStar Transmitter Loaner, Replacement & Repair Program provides a replacement transmitter, or loaner transmitter while your transmitter is being repaired. Under the terms of the Loaner, Replacement and Repair Program, please provide a purchase order or credit card to cover the cost of the loaner transmitter.

If you need to return a defective transmitter, please follow the steps below.

1. Request a Return Authorization (RA) from Electromotive Systems' Service Department and return the defective transmitter to Electromotive Systems **via pre-paid freight. When you call, please have the information from the serial nameplate of the transmitter available.**
2. Electromotive Systems will ship a loaner or replacement transmitter within 24 business hours.
3. Electromotive Systems will inspect the defective transmitter and determine if the defects are covered under warranty. If the defects are covered under warranty, Electromotive Systems, at their discretion, will do one of the following:
  - Replace the defective transmitter with the loaner or equivalent transmitter. The replacement transmitter will be covered for the duration of the original transmitter warranty period.
  - Credit the full cost of the loaner transmitter, plus pay for all freight charges for both the loaner transmitter and the transmitter repaired under warranty.

***NOTE: Freight charges incurred from sources other than common ground carriers WILL NOT be reimbursed unless pre-approved by Electromotive Systems.***

  - If the defects are not covered under warranty, Electromotive Systems will credit the cost of the loaner transmitter, less the cost of the repairs, a \$50 loaner inspection fee, and any freight charges incurred by Electromotive Systems.
4. Electromotive Systems will repair or replace the transmitter. Repaired transmitters will be shipped from Electromotive Systems within 72 business hours of receipt of transmitter (three working days).

5. If the original transmitter is repaired, return the loaner transmitter in good condition to Electromotive Systems **via prepaid freight**.

## **Receiver Repair Program**

The process for returning a defective PulseStar•jr. receiver is described in the following steps.

1. Request a Return Authorization (RA) from Electromotive Systems' Service Department and return the defective receiver to Electromotive Systems via prepaid freight. You are responsible for the shipping charges for sending the defective parts to Electromotive Systems.
2. Electromotive Systems will inspect the receiver and determine if the defects are covered under warranty.
  - If the defects are covered under warranty, Electromotive Systems will repair the receiver at no cost, and credit the full cost of all freight charges.

***NOTE: Freight charges incurred from sources other than common ground carriers WILL NOT be reimbursed unless pre-approved by Electromotive Systems.***

- If the defects are not covered under warranty, you are responsible for the cost of the repairs and all freight charges.

# Limited Warranty And Terms Of Sale

**Prices:** Subject to Change Without Notice

**Terms:** Net 30 Days

**F.O.B.** Electromotive Systems

Milwaukee, Wisconsin

Electromotive Systems, hereafter referred to as Company, guarantees all items manufactured by it against any defects of material and/or workmanship for a period of two years from the date of shipment. Company makes **NO OTHER WARRANTY, EXPRESSED OR IMPLIED, AS TO THE MERCHANTABILITY OR FITNESS OF THE ITEMS FOR THEIR INTENDED USE OR AS TO THEIR PERFORMANCE.** Any statement, description or specification in Company's literature is for the sole purpose of identification of items sold by the Company and imparts no guarantee, warranty or undertaking by company of any kind. Components and accessories not manufactured by Electromotive Systems are not included in this warranty and are warranted separately by their respective manufacturers.

Company's sole liability shall be to repair at its factory, or replace any item returned to it within two years from date of shipment, which Company finds to contain defective material or workmanship. All items to be repaired or replaced shall be shipped to Company (Note: return authorization by Company is required) within said two year period, freight prepaid, as a condition to repair or replace defective material or workmanship. Company's herein assumed responsibility does not cover defects resulting from improper installation, maintenance, or improper use. Any corrective maintenance performed by anyone other than the Company during the warranty period shall void the warranty. Company shall not be liable for damages of any kind from any cause whatsoever beyond the price of the defective Company supplied items involved. Company shall not be liable for economic loss, property damage, or other consequential damages or physical injury sustained by the purchaser or by any third party as a result of the use of any Company supplied items or material.

Company neither assumes nor authorizes any other person to assume for Company any other liability in connection with the sale or use of items sold by Company.

List prices or discounts are subject to change without notice. Quoted prices will be honored for a period of 30 days from the date of the written quotation unless otherwise stated.

Orders of \$25,000 or more, and orders for special control panels are subject to special terms and conditions of sale. Refer to those specific sections within this document.

Orders are not subject to alteration or cancellation except upon written consent of Company and payment of proper cancellation charges, when deemed applicable by Company.

Materials or items may not be returned for credit, without the prior written consent of the Company. Any authorized return of materials or items shall be subject to a restocking charge equal to 20% of the net invoiced amount after Company determines that the material or item is in good condition and may be resold without alteration or service. If upon receipt of the material or items returned, the Company determines that said materials or items cannot be resold without alteration or service, the Company reserves the right to reject the returned materials or items and to send the same back to said purchaser at purchaser's expense.

Terms of payment are NET 30 days. All materials and items are sold F.O.B. Company's shipping point. Company retains a security interest in all items sold by it so long as they remain in Company's possession to secure all obligations of purchaser to Company. A processing fee will be applied to all invoices for requested prepaid freight charges other than UPS. A service charge will be incurred on past due accounts extending beyond the Terms of Sale described above, at a rate of 1.5 per month or a fraction thereof, of the net balance extending beyond 30 days..

Any claim for errors in shipment or for material or item shortages must be received by Company within 30 days of shipment and must be accompanied by copies of the bill of lading and packing slip.

## **Special Terms and Conditions: Orders of \$25,000 or More**

### **Electrification and Control Orders**

#### **Drawings and Drawing Approvals (if applicable)**

In most cases, Electromotive Systems will submit drawings for customer approval within 30 days after receipt of purchase order.

Customer drawing approval and Electromotive Systems credit approval is required before Electromotive Systems will proceed with parts procurement or assembly work.

#### **Progress payment**

25% of total order is required prior to shipment.

75% balance to be paid Net 30 days upon shipment of order.

#### **Customer Requested Changes**

Customer shall pay for any additional charges that may be incurred due to customer change orders as incurred.

#### **Cancellation Policy**

Cancellation fee of 10% of orders, plus all charges that may be incurred to-date of cancellation, will be applicable to all orders cancelled after receipt of order.

#### **Credit Approval**

All orders are subject credit approval by Electromotive Systems.

All items manufactured and offered for sale by Electromotive Systems are subject to limited warranty and terms of sale. These special terms and conditions are part of the limited warranty and terms, and only supersede to take exception to said warranty and terms section of this document for a complete description.

## **Special Terms and Conditions: Orders for Special Control Panels**

### **Drawing and Drawing Approvals**

In most cases, Electromotive Systems will submit drawings for customer approval within 30 days after receipt of purchase order.

Customer drawing approval and Electromotive Systems credit approval is required before Electromotive Systems will proceed with parts procurement or assembly work.

#### **Progress payments**

25% of total net order is required upon drawing approval.

25% of total net order is required prior to shipment.

50% balance to be paid Net 30 days upon shipment of order.

#### **Customer Requested Changes**

Customer shall pay for any additional charges that may be incurred due to customer change orders as incurred.

**Cancellation Policy**

Cancellation fee of 10% of order, plus all changes that may be incurred to-date of cancellation, will be applicable to all orders cancelled after receipt of purchase order.

**Credit Approval**

All orders are subject to credit approval by Electromotive Systems.

All items manufactured and offered for sale by Electromotive Systems are subject to limited warranty and terms of sale. These special terms and conditions are part of the limited warranty and terms, and only supersede to take exception to said warranty and terms as specifically outlined. Refer to limited warranty and terms section of this document for a complete description.