

ReFlx 100 “PLUS” COLLISION AVOIDANCE SYSTEM

The ReFlx 100 “Plus” collision avoidance system is intended for use with bridges and trolleys to prevent collisions or to limit the approach of adjacent bridges or trolleys. The system is designed to be immune to most electrical noise including that which can be created by variable frequency drives and other parasitic interference affecting the reliability of RF based systems.

The ReFlx 100 “Plus” system is a three channel system. It uses a two channel light sensor, a single channel light sensor, a diamond grade reflective target, and controller containing the power supply and relay outputs.

System Includes:

- 1-RFX100-2 Dual Channel Sensor with 5 meter control cable
- 1-RFX100-1 Single Channel Sensor with 5 meter control cable
- 1-ST100-3 Controller
- 1-2ft. X2ft. (T2X2) Diamond Reflective Target

ST100-3 Controller

The ST100-3 controller features two 10 amp relays for inter-connection with the crane motion controls. The power supply is normally 120/1/60. The system can be specified in voltages of 220 VAC, 250 VDC, or 350 VDC.

RFX 100-2 Sensor

The RFX 100-2 sensor has two channels in a single compact housing that can be individually adjusted to a scanning range of 120 feet by using a diamond grade reflective material. The first channel provides a “slow-down” command or warning signal (horn or light). The second channel is used to provide the primary stop command to the motion control.

An infrared LED light source sends a pulsed light that is reflected back when the reflective material comes within the set range (maximum 120 feet).

The sensor is in the dark switching mode. Meaning, the controlling relay contacts close on power up and will open if there is a loss of power or the diamond grade material is detected.



ST100-3 Controller

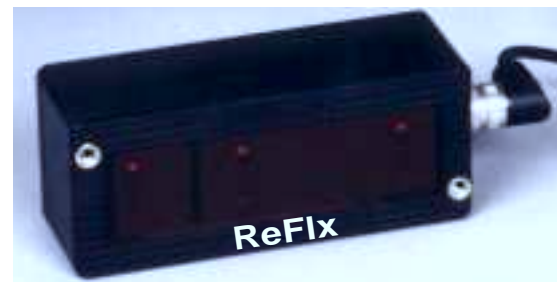

RFX 100-2

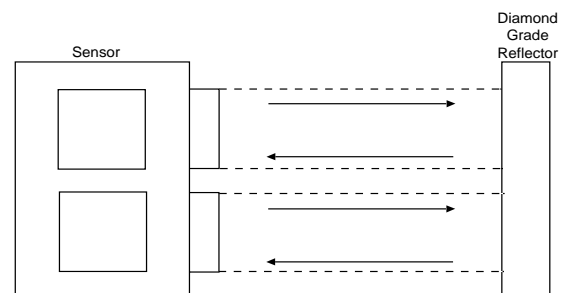

RFX100-1 Sensor

This sensor is not intended to be a primary stopping sensor but is used to provide a backup safety stop.



RFX 100-1

An infrared LED light source sends a pulsed light that is reflected back when the crane or other object comes within the set range. No target is used. Instead, it uses the object to be detected regardless of color and texture surface. The sensor has an adjustable range of 18 inches to 20 feet.

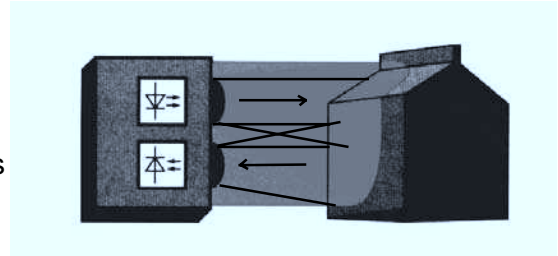

ReFlx 100 “Plus” Application Guidelines

Contactor Control

Bridge and trolley motions using reversing contactors for control, rely on the crane’s mechanical brakes for stopping. Therefore, the buffer zone (minimum distance to mating crane or obstruction) should be sized to allow for future brake wear.

Adjustable Frequency Crane Control

Because adjustable frequency drives (AFD) have various programmable stopping options, consideration should be given to these various means when setting up the ReFlx 100 “Plus” system.

Using the AFD Limit Switch Inputs

Most modern AFDs include programmable limit switch input terminals for each direction of travel (Upper Limit 1 & Upper Limit 2), with provision for automatic slow-down. As soon as the bridge reaches the sensing distance for Channel 1, the drive will command the crane to slow down using a separately programmable speed switch frequency and deceleration time. When the bridge reaches the sensing distance for Channel 2 or 3, the drive will “decelerate at stop command” or provide “immediate stop at stop command” (see definitions below), depending on how the drive is programmed. The input to the drive from Channel 3 can be run parallel to that of Channel 2, or run to a multi-function input terminal on the AFD.

Decelerate at “Stop Command”

Upon receiving a “Stop Command” from the ReFlx 100 “Plus” system, the output frequency of the AFD decreases to near zero at the programmed deceleration ramp; and the brake is commanded to set. See Table I, Bulletin A260.10 for approximate stopping distances at various deceleration times. These stopping distances will be slightly longer when the AFD is programmed with an S-Curve ramp.

Immediate Stop at Stop Command

Upon receiving a “Stop Command” from the ReFlx 100 “Plus” system, the AFD base blocks the main output transistors, thereby electrically disconnecting the motor from the AFD, and through the brake interlock, commands the brake to set. In this mode, the crane functions similar to Contactor Control and relies on the crane’s mechanical brakes for stopping. Therefore, the buffer zone (minimum distance to mating crane or obstruction) should be sized to allow for future brake wear.

NOTE: It may be necessary to re-calibrate the ReFlx 100 “Plus” system whenever the deceleration time is changed. Test all motions under worst case scenario before putting crane into operation.

Contact Electromotive Systems for applications involving other types of controls or options.

Crane to Wall Collision Avoidance

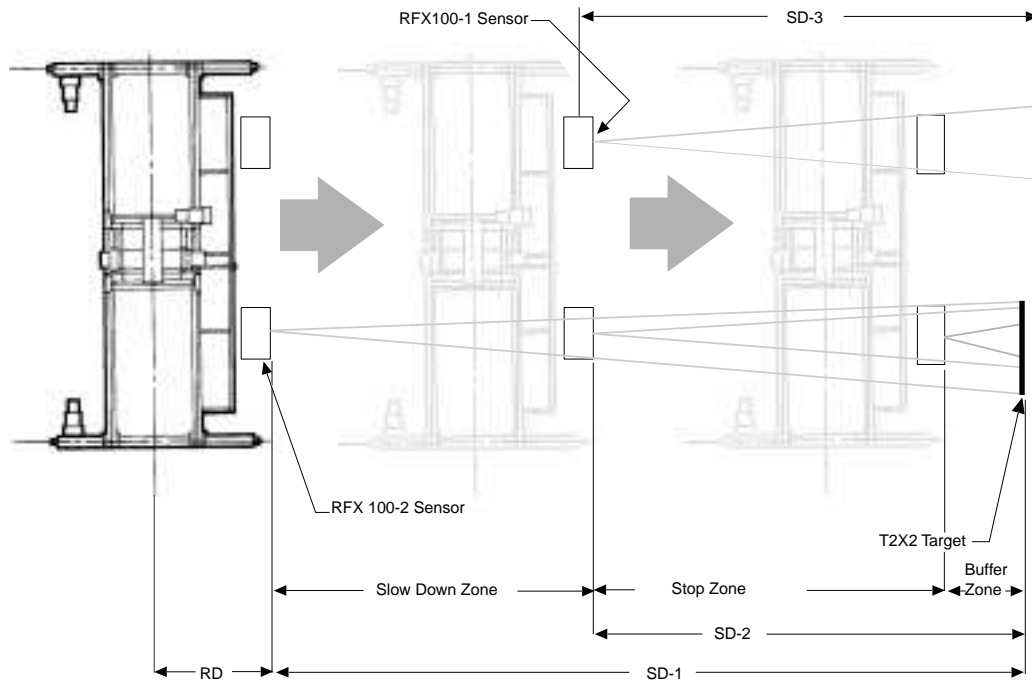

- SD-1** = Sensing Distance for Channel No. 1
- SD-2** = Sensing Distance for Channel No. 2
- SD-3** = Sensing Distance for Channel No. 3
- RD** = Distance – CL of Crane to ReFlx Sensor

Mounting Guidelines

The T2X2 reflector is used as the target for the RFX100-2 sensor. The wall or other object is used as the target for the RFX100-1 sensor. Each sensor shall be mounted horizontally and perpendicular to its respective target, in both the horizontal and vertical planes, with the optical axis parallel to the line of travel, and approximately three (3) feet away from the walls and ceilings. In addition, separate the two sensors by at least three feet on either the vertical or horizontal axis. For outdoor applications, additional protection may be needed to protect the sensors from the elements. Contact Electromotive Systems for application assistance.

Crane to Crane Collision Avoidance

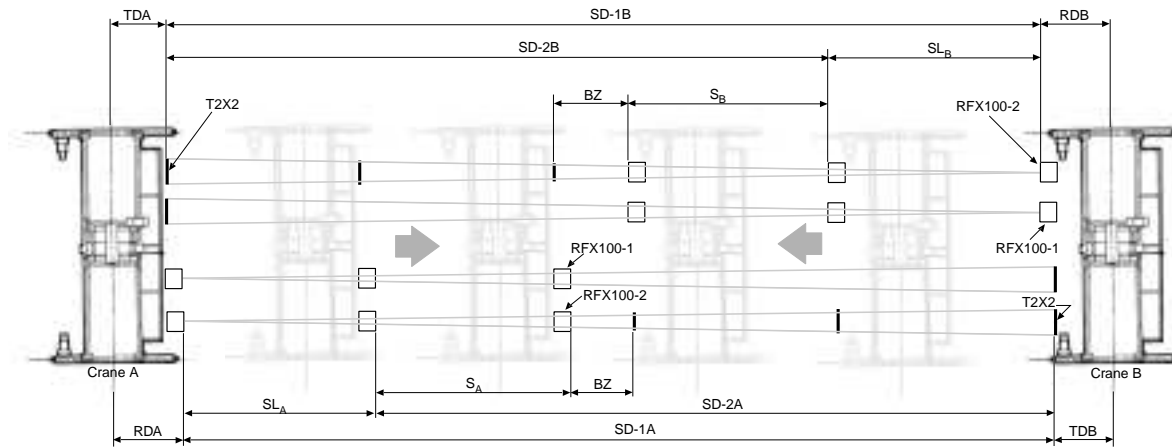

SD-1A = Sensing Distance for Channel 1
SD-2A = Sensing Distance for Channel 2
RDA = Dist. - CL of Crane A to ReFlx Sensor
TDA = Dist. - CL of Crane A to Target B
S_A = Stopping Distance For Crane A
SL_A = Slow-down Distance For Crane A
BZ = Buffer Zone

SD-1B = Sensing Distance for Channel 1
SD-2B = Sensing Distance for Channel 2
RDB = Dist. - CL of Crane B to ReFlx Sensor
TDB = Dist. - CL of Crane B to Target A
S_B = Stopping Distance For Crane B
SL_B = Slow-down Distance For Crane B

Mounting Guidelines

The T2X2 reflector is used as the target for the RFX100-2 sensor. The adjacent crane is used as the target for the RFX100-1 sensor. Each sensor shall be mounted horizontally and perpendicular to its respective target, in both the horizontal and vertical planes, with the optical axis parallel to the line of travel, and approximately three (3) feet away from the walls and ceilings. In addition, separate the two sensors by at least three feet on either the vertical or horizontal axes.

To avoid cross-talk when mounting two or more sensors facing each other, separate them by at least three feet on either the vertical or horizontal axes. When the sensors are mounted on cranes that travel more than 100 feet apart, allow an additional foot of spacing between them for every fraction of 100 feet. For example, if two cranes are separated by 165 feet, allow 3 feet plus 1 foot for the additional 65 feet. Stopping distances should be determined to allow for a buffer zone with both cranes traveling toward each other at maximum velocity.

For outdoor applications, additional protection may be needed to protect the sensors from the elements. Contact Electromotive Systems for application assistance.

Connecting the RFX 100-2 and RFX 100-1 Sensors to the ST100-3 Controller

The shielded connector cables are furnished with a 5 pin Amphenol Mil Spec plug at both ends for the RFX100-2 sensor and with a 6 pin plug at both ends for the RFX100-1 sensor. Plug the 5 pin angled connector into the socket on the RFX 100-2 two channel sensor, and the straight connector into the left hand receptacle on the ST100-3 controller. Plug the cable with straight 6 pin connectors at both ends into the socket of the RFX100-1 sensor and the right hand receptacle on ST100-3.

The RFX 100-2 sensor will not operate when plugged into the receptacle for the RFX 100-1 sensor (Channel 3).

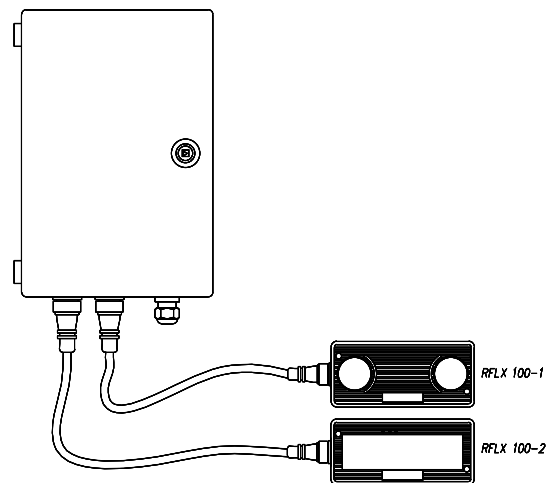

ELECTRICAL INSTALLATION

Note: Installation should be performed by qualified personnel only. National Electric Code and local electrical installations requirements and codes should be followed.

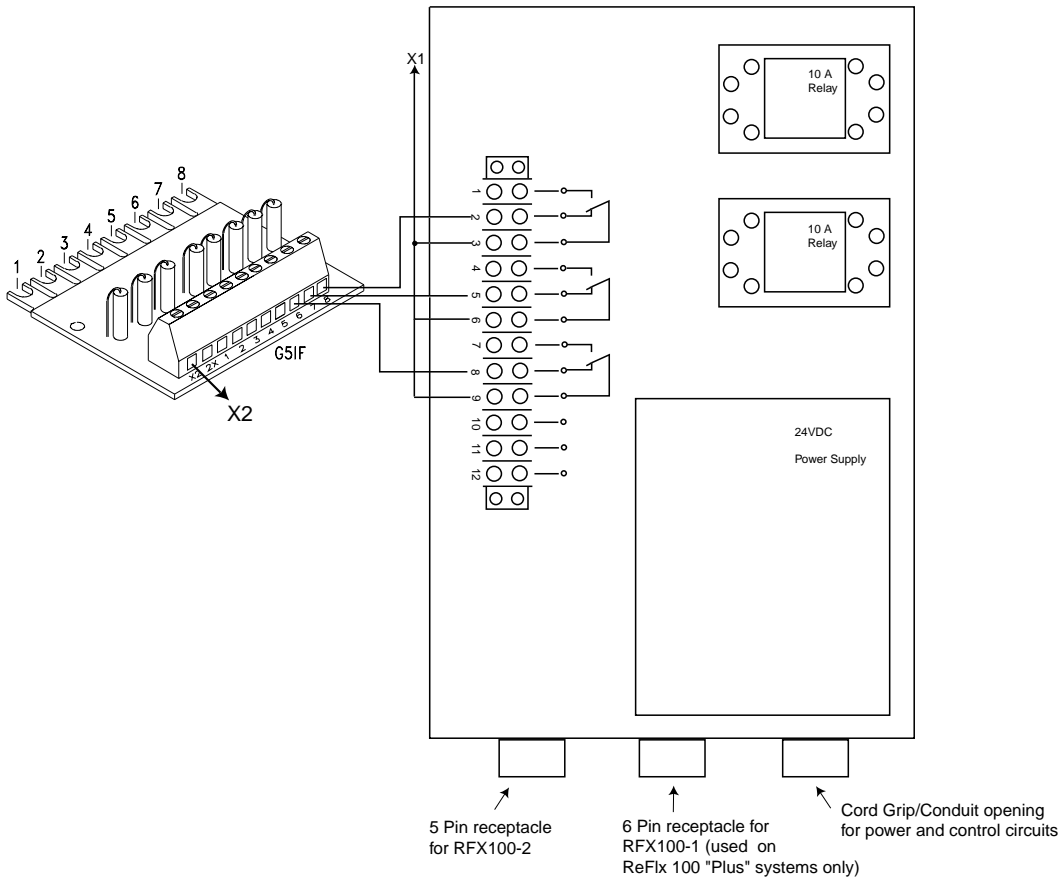

ST100-3 Controller

Terminal Description/Wiring Notes:

1. Terminals 1 & 4 are open with power "Off". Upon "power-up", the respective relay contacts change state, unless the reflector for that particular scanner is within the set range. The relay contacts will open upon loss of power or if the reflector is within the set range.
2. Terminals 2 & 5 are closed with power "Off". Upon "power-up", the respective relay contacts change state, unless the reflector for that particular scanner is within the set range. The relay contacts will close upon loss of power or if the reflector is within the set range.
3. The switching contacts for channel 3 are made within the RFX100-1 sensor and wired to terminals 7, 8 and 9. Terminal 7 functions the same as terminals 1 & 4. Terminal 8 functions the same as terminals 2 & 5.
4. Terminals 10 & 12 are used for the 120/1/60 input power supply. A grounding lug is furnished on the inside of the enclosure door.

RFX 100-2 Two Channel Sensor Set-Up Guidelines:

Adjustment:

Tools required; regular screwdriver, adjustable wrench

1. To adjust the range of the RFX 100-2, look at the face of the sensor (side with optics window and tag). The adjustment for channel 1 is closest to the yellow indicator and the adjustment for channel 2 is closest to the red indicator.

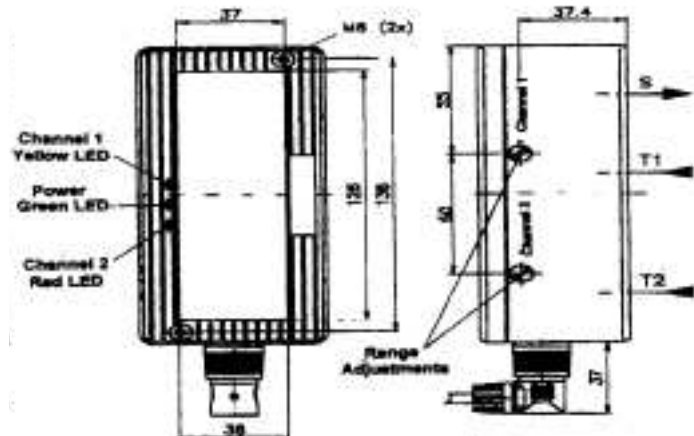

2. Upon powering up the RFX 100-2, the green indicator light should come on and the normally open contacts on the relays in the control enclosure should close. The other indicator lights (red and yellow) should be off, unless the diamond grade reflective material is in the scanning range. If the red or yellow indicator LED is on, turn the corresponding adjustment clockwise until the indicator goes off. If either the red or yellow LED fails to turn off, return the unit.
3. Move the crane so that the diamond grade reflective material in the sensing path is at the "Slow Down" sensing distance (SD-1). Channel 1 is used to provide a "Slow Down" command or warning signal(horn or light) to the motion control. Turn the adjustment on Channel 1 counterclockwise until the yellow indicator comes on.

Now move the crane so it is 3 to 4 feet further from the face of the target and turn the Channel 1 adjustment clockwise until the yellow indicator just turns off.

4. Channel 2 is used to provide a primary stop command to the motion control. Move the crane so that the diamond grade reflective material in the sensing path is at the stop sensing distance (SD-2). Turn the adjustment on Channel 2 counterclockwise until the red indicator comes on.

Now move the crane so it is 3 to 4 feet further from the face of the target and turn the Channel 2 adjustment clockwise until the red indicator just turns off.

5. It may be necessary to re-calibrate the ReFlx 100 system whenever the deceleration time is changed. Test all motions under worst case scenario before putting crane into operation.

WARNING: Detection systems which are not operational cannot stop crane motion or warn about possible collision. Trusting an inoperative device can result in collisions causing severe injury, death or property damage. Avoid sudden stops. The RFX 100-2 two channel system requires that a diamond grade reflective grade material be present and that the reflective properties of this material not be compromised.

RFX 100-1 Single Channel Sensor Set-Up Guidelines

- 1 The RFX 100-1 sensor (channel 3) gives the added security of a second sensor which is used to provide a backup stop for channel 2. It does not use the diamond grade material for detection. Instead, it uses the object to be detected regardless of color and texture. It has an adjustable operating range of 18 inches to 20 feet.
- 2 Upon powering up the RFX 100-1 the green indicator light should come on and the normally open contacts in the sensor should close. The other indicator light should be off, unless the object to be detected is in the scanning range. If the yellow indicator LED is on, turn the corresponding adjustment clockwise until the indicator goes off. Move the crane to the stop sensing distance (same as Channel 2) and turn the adjustment until this yellow LED comes on.

Now move the crane 3 to 4 feet away from the object to be detected (wall or adjacent crane) and turn the Channel 3 adjustment clockwise until the yellow indicator just turns off.

3. Channel 3 should be set at the same sensing range as channel 2.

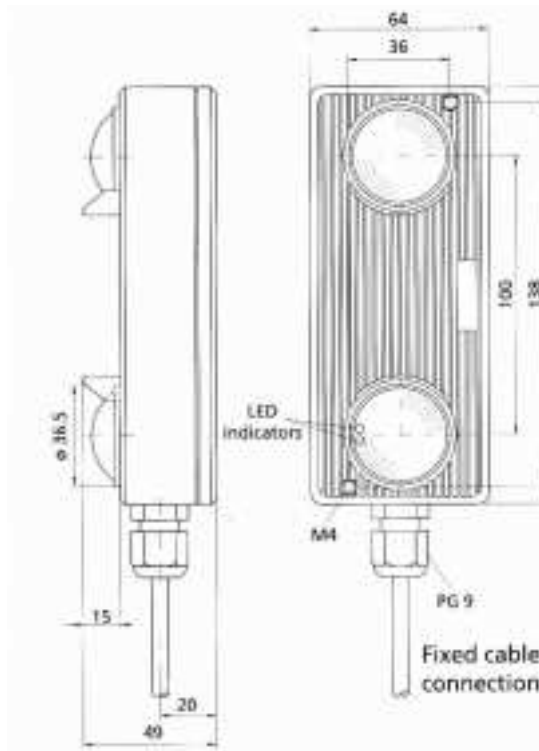

RFX100-1 Third Channel Sensor

The RFX100-1 has standard start-up and switch off inhibits. All inputs and outputs are reverse polarity protected and are also short circuit proof.

Test Input

The RFX100-1 has a test input, via which the light transmitter can be switched off. This permits checking of the complete optical system including the electronics and supply. This test can only be carried out in background **suppression** mode if there is an object in the sensors' scanning field.

Programming Functions

Adjustment of the 4 programming functions is by means of a DIP switch which is on the reverse side of the printed circuit board. Just the housing cap must be removed to gain access.

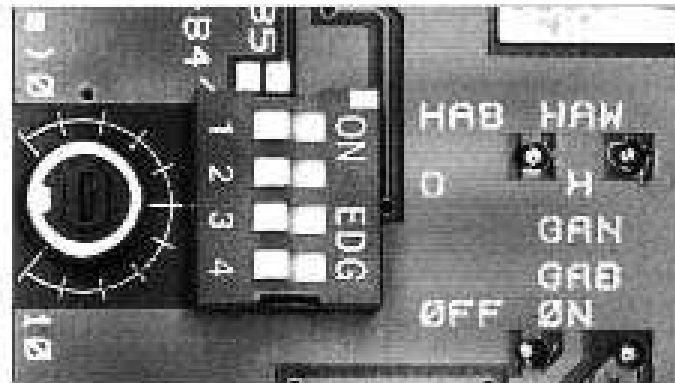

The functions described are programmed as follows:

- **Switch 1 - Operating Mode**
HAW - background evaluation
HAB - background suppression **OFF**
- **Switch 2 - Switching Mode**
H-light switching
D-dark switching **OFF**
- **Switch 3- Timing Function**
GAN - pull in time delay **OFF**
- **Switch 4 - Timing Function**
GAB - drop out time delay **OFF**

The potentiometer to the left of the switches adjusts times for GAN or GAB but is not normally used.

The RFX100-1 is supplied in the background suppression operating mode and should not be changed.

RFX 100-1 Single Channel Sensor
Technical Data:

Scanning Range: 0.2 - 6 meter on material with a reflection value >6%

Light Beam: Modulated infrared

Transmitter: IRED

Receiver: Photo-diode

Response/drop out time:
 100ms 'AN with light to dark ratio of 1:1

Supply voltage: 12-24VAC/11-48VDC

Power consumption: <100mA

Switching output: Voltage free relay contacts

Switching voltage: Maximum 240 V AC/DC

Switching current: Maximum 2 A

Test input: transmitter off when connecting
 15 - 35 VDC

Function indicators: green and yellow LEDs



RFX 100-1 Sensor

Switching mode: light or dark

Operating mode: Background suppression

Timing functions: pull in or drop out time delay

Type connection: 5 meter cable with 6 pin
 Amphenol Mil spec connector

Housing material: Macrolon, fiberglass reinforced plastic

Protection category: IP 65

Operating temperature: -20 C to 60 C

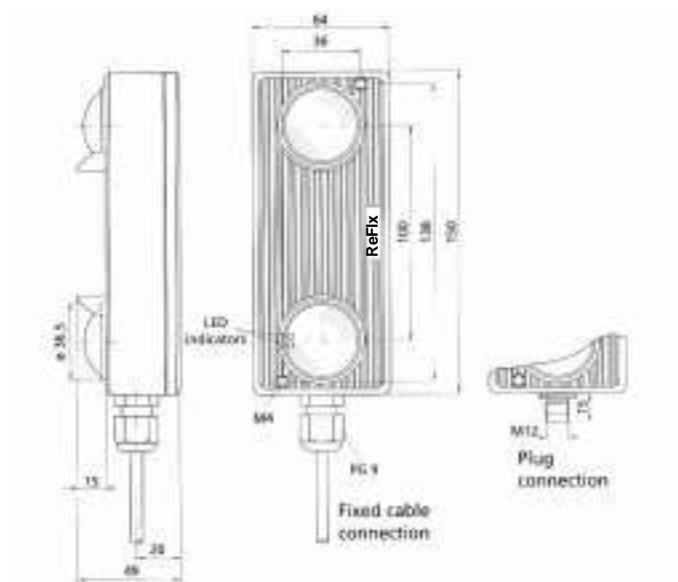

Mounting Dimensions

ST100-3 Controller

The ST100-3 controller consists of a power supply for the sensors and features one 10 Amp SPDT relay each, for channels No. 1 & 2 for output to the crane motion controls, all mounted in a NEMA 12 enclosure. The switching contacts for channel 3 are made within the RFX100-1 sensor and wired to the terminal strip in the controller. The power supply is normally 120/1/60. The system can be specified in voltages of 220 VAC, 250 VDC, or 350 VDC on special order.

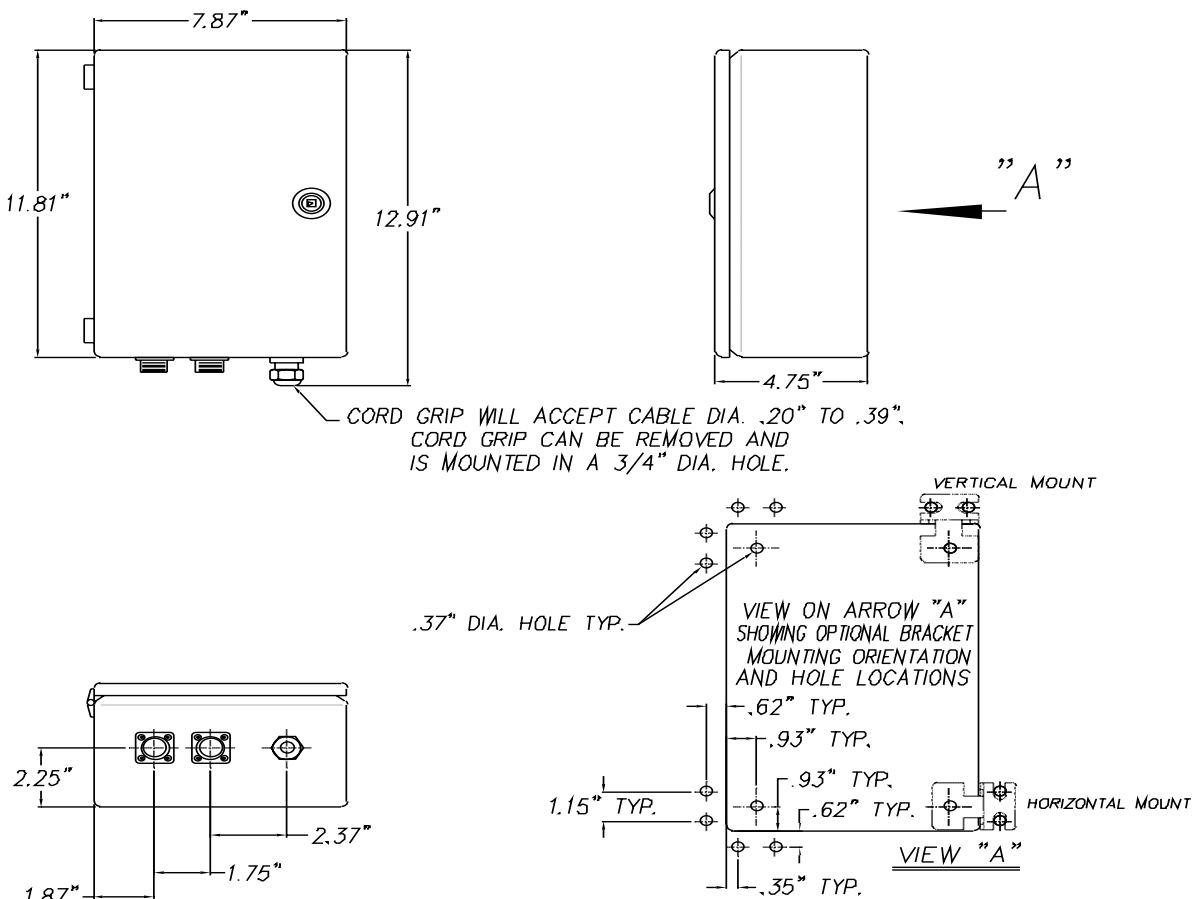

ENCLOSURE COMES WITH ONE SET OF MOUNTING BRACKETS
THE BRACKETS CAN BE MOUNTED IN TWO ORIENTATIONS.
HOLES FOR INSTALLATION OF BRACKETS ARE INCLUDED IN ENCLOSURE

Dimensions