

SHAW-BOX® Quick Reference List

Single reeved hoists for single girder cranes

Contact Muskegon Customer Service
 Toll Free 800 742-9269
 Direct Dial 231 733-0821
 Toll Free Sales/Service Fax 800 742-9270
 Direct Dial Sales Service Fax 231 733-3401

Cap. Tons	Max Lift (ft)	Hoist Spd. fpm	Model Number	List Price w/MDT	Net Wt.	Trolley			Hoist Motor HP	Rope Dia.	Fig. No.	A	AQ	D	WB	Beam*			Max. High Hook W. L.
						Motor HP	Speed FPM	Whl. Dia.								Min. Width	Max. Width	Min. Depth	
5	25	20/5	WB3M05-025S20-2	7871	900	.5/1.67	55/18	4	7.5/1.875	9 mm	1	20-9/16	5-1/2	14-1/8	28-9/16	4 5/8	20	8	3850
	40	20/5	WB3M05-040S20-2	8617	1050	.5/1.67	55/18	4	7.5/1.875	9 mm	2	30-3/8	8-7/8	14-1/8	41-3/4	4 5/8	20	8	4440
7½	25	20/5	WC3M07-025S20-2	13402	1750	.75/25	50/17	6	15/3.75	12 mm	2	20-15/16	5-5/8	18-1/8	30-1/8	6	20	10	5425
	40	20/5	WC3M07-040S20-2	14331	1900	.75/25	50/17	6	15/3.75	12 mm	2	31-1/16	9	18-1/8	43-5/8	6	20	10	6410
10	25	20/5	WC3M10-025S20-2	13402	1750	.75/25	50/17	6	15/3.75	12 mm	2	20-15/16	5-5/8	18-1/8	30-1/8	6	20	10	6935
	40	20/5	WC3M10-040S20-2	14331	1900	.75/25	50/17	6	15/3.75	12 mm	2	31-1/16	9	18-1/8	43-5/8	6	20	10	8226

*Based on US (short) ton rating.
 12" beam for 5 ton hoist
 14" beam for 7½ & 10 ton hoists
 Give proper beam flange width when ordering, no extra charge for 1st or 2nd extension.

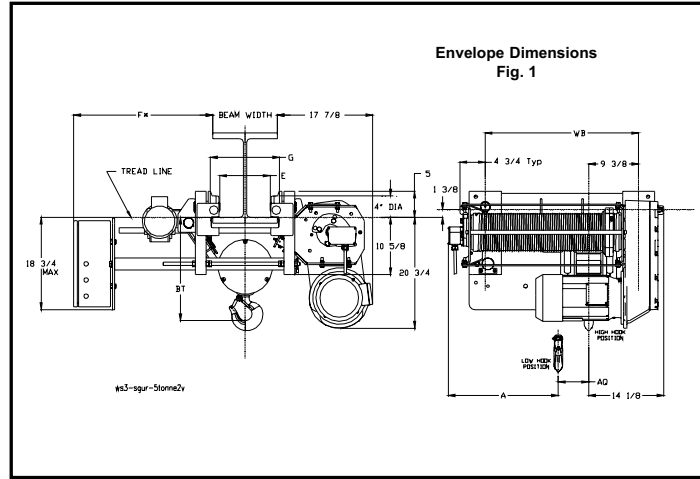

Dimension	Beam Flange Width										
	4 5/8	6	8	8-1/8	10	12	14	14-1/8	16	18	20
BT	22-5/8	21-15/16	21	21-1/16	20	19-1/4	20-5/16	20-3/8	21-7/16	22-1/2	23-5/8
E	2	3-3/8	5-3/8	5-1/2	7-3/8	9-3/8	11-3/8	11-1/2	13-3/8	15-3/8	17-3/8
F*	27-7/16	26-1/16	24-1/16	29-15/16	28-1/16	26-1/16	24-1/16	29-15/16	28-1/16	26-1/16	24-1/16
Trolley Ext.	Base Trolley 4-5/8" - 8"			1 st Extension 8-1/8" - 14"				2 nd Extension 14-1/8" - 20"			

* Add 2-5/16" for 208/230 or 575 Volt panels
 ** Add 1-1/2" for 208/230 or 575 Volt panels

Optional Equipment

- TROLLEY OPTIONS:**
- Add soft-start to standard 2 speed trolley Add 375
 - Variable frequency trolley control
 - Electromotive P3 for 230 or 460/3/60 Add 735
 - Trolley brake, AC motor mounted disc type rated at 50% torque Add 422
 - Trolley bumpers, four (4) rubber bumpers mounted two (2) at each end Add 195

For pushbutton station (shipped loose)

Lift	Four 2-Speed w/Cable	To Add Extra Buttons		
		Two 2-Speed	Two 1-Speed	Two Main Line
25'	307	74	63	63
40'	352			

(Pendant Stations Not Included with Base Hoist Price)

Attach and wire pendant to hoist Add 52

List prices are arranged by the various button combinations available per hoist lift.
 Price includes NEMA 4 pendant station with the button quantity listed, control and strain reliever cable for the hoist lift selected.
 The length of the cables will be approximately equal to the lift less 2½ feet.
 The pendant will ship loose for field installation by others.
 Please give desired configuration with order.

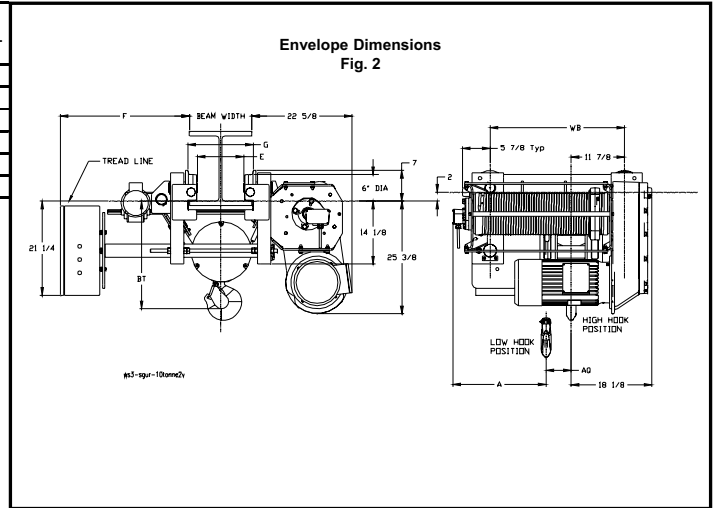

Dimension	Beam Flange Width									
	6	8	8-1/8	10	12	14	14-1/8	16	18	20
BT	27-3/16	26-1/2	26-1/2	26-3/8	25-9/16	24-1/4	24-1/4	25-1/2	26-11/16	28
E	2-3/8	4-3/8	4-1/2	6-3/8	8-3/8	10-3/8	10-1/2	12-3/8	14-3/8	16-3/8
F	31-3/16	29-3/16	35-1/16	33-3/16	31-3/16	29-3/16	35-1/16	33-3/16	31-3/16	29-3/16
Trolley Ext.	Base Trolley 6" - 8"		1 st Extension 8-1/8" - 14"				2 nd Extension 14-1/8" - 20"			

- HOIST OPTIONS:**
- Upper block operated control circuit limit switch Add 455
 - Add mainline contactor Add 468
 - 575/3/60 hoist & trolley motors and controls (2-speed) Add N/C