

# SHAW-BOX® Quick Reference List

## Single reeved hoists for single girder cranes

Contact Muskegon Customer Service  
 Toll Free ..... 800 742-9269  
 Direct Dial ..... 231 733-0821  
 Toll Free Sales/Service Fax ..... 800 742-9270  
 Direct Dial Sales Service Fax ..... 231 733-3401

Cap. Tons	Max Lift (ft)	Hoist Spd. fpm	Model Number	List Price w/MDT	Net Wt.	Trolley			Hoist Motor HP	Rope Dia.	Fig. No.	A	AQ	D	WB	Beam*			Max. High Hook W. L.
						Motor HP	Speed FPM	Whl. Dia.								Min. Width	Max. Width	Min. Depth	
1	40	24/6	WA3M01-040S24-2	6120	625	25/08	50/17	3-3/4	3.0/75	6.4 mm	1	14-3/8	7	12-7/8	18-1/2	4-5/8	14	8	1133
2	20	20/5	WA3M02-020S20-2	6420	700	5/17	50/17	3-3/4	5.0/1.25	6.4 mm	2	14-3/4	3-1/2	16	18-1/2	4-5/8	14	8	1661
	40	20/5	WA3M02-040S20-2	6720	800	5/17	50/17	3-3/4	5.0/1.25	6.4 mm	2	25	7	16	32-1/4	4-5/8	14	8	1999
3	20	20/5	WA3M03-040S20-2	6420	700	5/17	50/17	3-3/4	5.0/1.25	6.4 mm	2	14-3/4	3-1/2	16	18-1/2	4-5/8	14	8	2329
	40	20/5	WA3M03-040S20-2	6720	800	5/17	50/17	3-3/4	5.0/1.25	6.4 mm	2	25	7	16	32-1/4	4-5/8	14	8	2809

\*Based on US (short) ton rating.  
 Give proper beam flange width when ordering, no extra charge for 1st extension.

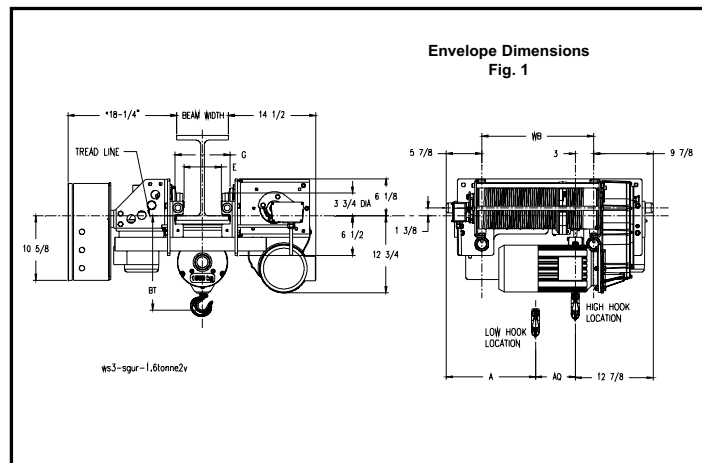

### Optional Equipment

- TROLLEY OPTIONS:**
- Add soft-start to standard 2 speed trolley for 230 or 460/3/60 ..... Add ..... 375
  - Add soft-start to standard 2 speed trolley for 575/3/60 ..... Add ..... 735
  - Variable frequency trolley control
  - Electromotive P3 for 230 or 460/3/60 ..... Add ..... 1017
  - Trolley brake, AC motor mounted disc type rated at 50% torque ..... Add ..... 422
  - Trolley bumpers, four (4) rubber bumpers mounted two (2) at each end ..... Add ..... 195

### For pushbutton station (shipped loose)

Lift	Four 2-Speed w/Cable	To Add Extra Buttons		
		Two 2-Speed	Two 1-Speed	Two Main Line
20'	292			
40'	352	74	63	63

(Pendant Stations Not Included with Base Hoist Price)  
**Attach and wire pendant to hoist** ..... Add ..... 52  
 List prices are arranged by the various button combinations available per hoist lift.  
 Price includes NEMA 4 pendant station with the button quantity listed, control and strain reliever cable for the hoist lift selected. The length of the cables will be approximately equal to the lift less 2 1/2 feet.  
 The pendant will ship loose for field installation by others. Please give desired configuration with order.

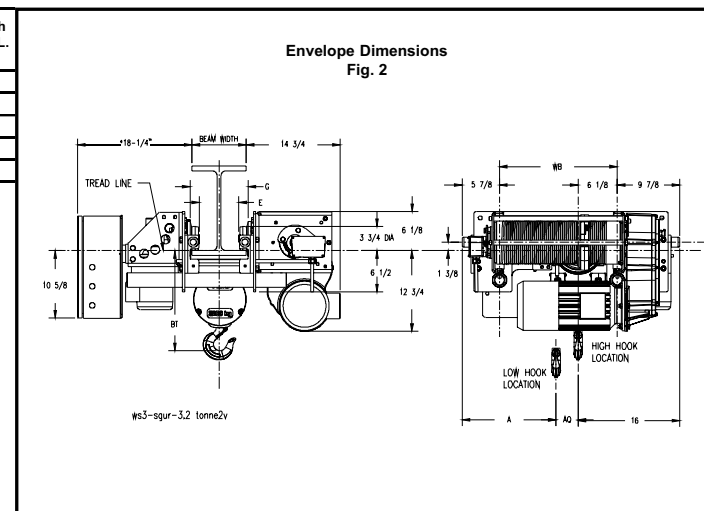

Dimension	Dimensions Affected by Beam Flange Width							
	Beam Flange Width							
BT	4 5/8	6	8	8 1/2	8 5/8	10	12	14
E	17	16-1/2	16	16	16	16-1/2	18	20
Trolley Ext.	2-9/32	3-21/32	5-21/32	6-5/32	6-9/32	7-21/32	9-21/32	11-21/32
	Base Trolley 4-5/8" - 8-1/2"				Extension 8-5/8" - 14"			

- HOIST OPTIONS:**
- Upper block operated control circuit limit switch ..... Add ..... 455
  - Add mainline contactor ..... Add ..... 468
  - 575/3/60 hoist & trolley motors and controls (2-speed) ..... Add ..... N/C

Dimension	Dimensions Affected by Beam Flange Width							
	Beam Flange Width							
BT	4 5/8	6	8	8 1/2	8 5/8	10	12	14
E	16-3/4	16-1/4	15-3/4	15-3/4	15-3/4	16-1/4	17-3/4	19-3/4
Trolley Ext.	2-9/32	3-21/32	5-21/32	6-5/32	6-9/32	7-21/32	9-21/32	11-21/32
	Base Trolley 4-5/8" - 8-1/2"				Extension 8-5/8" - 14"			