

HARRINGTON NER/ER THREE PHASE ELECTRIC CHAIN HOISTS

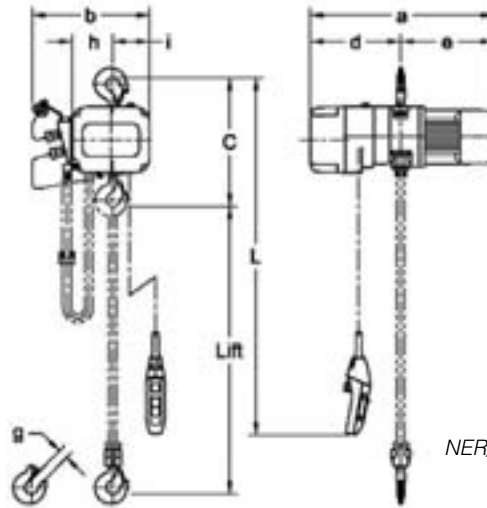

NER/ER010L
(Shown with optional
canvas chain container)



NER/ER010L

SINGLE SPEED — SPECIFICATIONS

Cap. (Tons)	Product Code	Standard Lift (ft)	Push Button Cord L (ft)	Lifting Speed (ft/min)	Lifting Motor 3 Phase 60 Hz			Load Chain Diameter (mm) x Chain Fall Lines	Net Weight (lbs)		Weight for Additional One Foot of Lift (lbs)
					Output (Hp)	Rated Current (amps)			NER	ER	
						@208 - 230V	@460V				
1/8	(N)ER001H	10	8.2	55	0.75	3.4	1.7	4.3 x 1	60	62	0.28
1/4	(N)ER003S			36	0.75	3.4	1.7	4.3 x 1	60	62	0.28
1/4	(N)ER003H			53	1.2	4.8	2.5	6.0 x 1	79	82	0.54
1/2	(N)ER005L			15	0.75	3.4	1.7	6.0 x 1	71	79	0.54
1/2	(N)ER005S			29	1.2	4.8	2.5	6.0 x 1	79	82	0.54
1	(N)ER010L			14	1.2	4.8	2.5	7.7 x 1	104	110	0.89
1	(N)ER010S			28	2.4	8.6	4.2	7.7 x 1	119	119	0.89
1 1/2	(N)ER015S			18	2.4	8.6	4.2	10.2 x 1	159	170	1.6
2	(N)ER020C			7	1.2	4.8	2.5	7.7 x 2	130	134	1.8
2	(N)ER020L			14	2.4	8.6	4.2	10.2 x 1	161	174	1.6
2	(N)ER020S			28	4.7	16.4	7.9	10.2 x 1	201	198	1.6
2 1/2	(N)ER025S			22	4.7	16.4	7.9	11.2 x 1	227	225	1.9
3	(N)ER030L*			16	4.7	18.3	9.2	12.5 x 1	256	256	2.3
3	(N)ER030C			17	4.7	16.4	7.9	10.2 x 2	234	234	3.2
5	(N)ER050L			11	4.7	16.4	7.9	11.2 x 2	289	284	3.8

*The (N)ER030L listed is the previous hoist model. Refer to Harrington catalog C-EPH for features and benefits.

NER/ER Electric Chain Hoists with Hook and Lug Suspensions



NER/ER020L
 (Shown with optional canvas chain container)

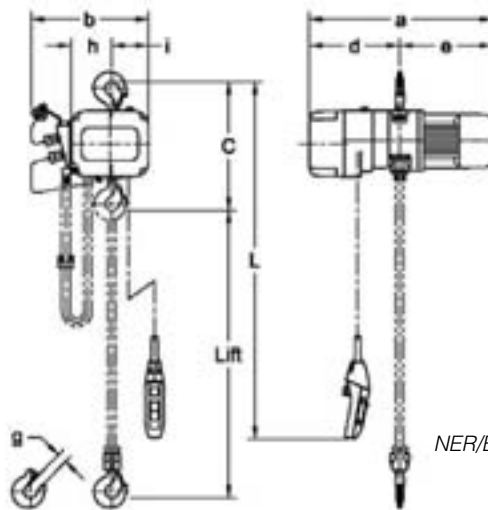

NER/ER020L

SINGLE SPEED — DIMENSIONS

Cap. (Tons)	Product Code	Headroom C (in)	a (in)		b (in)		d (in)		e (in)		g (in)	h (in)	i (in)	
			NER	ER	NER	ER	NER	ER	NER	ER			NER	ER
1/8	(N)ER001H	13.8	18.8	22.2	12.6	13.6	8.6	12.0	10.2	10.2	1.1	3.9	3.7	4.6
1/4	(N)ER003S	13.8	18.8	22.2	12.6	13.6	8.6	12.0	10.2	10.2	1.1	3.9	3.7	4.6
1/4	(N)ER003H	14.6	20.1	23.3	13.7	13.7	9.5	12.8	10.6	10.6	1.1	4.5	4.2	4.2
1/2	(N)ER005L	14.6	20.2	23.6	13.7	13.7	9.5	12.8	10.7	10.8	1.1	4.5	4.2	4.2
1/2	(N)ER005S	14.6	20.1	23.3	13.7	13.7	9.5	12.8	10.6	10.6	1.1	4.5	4.2	4.2
1	(N)ER010L	16.9	23.2	24.9	14.8	14.8	11.5	13.1	11.7	11.8	1.2	5.1	4.6	4.6
1	(N)ER010S	16.9	23.5	25.2	14.8	14.8	11.5	13.1	12.1	12.1	1.2	5.1	4.6	4.6
1 1/2	(N)ER015S	20.1	25.4	29.1	16.8	16.8	12.1	15.6	13.3	13.4	1.3	6.3	5.4	5.4
2	(N)ER020C	27.8	23.2	24.9	14.8	14.8	11.5	13.1	11.7	11.8	1.5	7.0	2.7	2.7
2	(N)ER020L	22.6	25.4	29.1	16.8	16.8	12.1	15.6	13.3	13.4	1.5	6.3	5.4	5.4
2	(N)ER020S	23.2	27.7	30.8	16.8	16.8	13.7	16.8	14.0	14.0	1.5	6.3	5.4	5.4
2 1/2	(N)ER025S	24.6	29.0	32.5	17.5	17.5	13.3	16.8	15.7	15.7	1.5	6.9	5.6	5.6
3	(N)ER030L*	26.0	30.9	30.9	18.9	18.9	15.5	15.5	15.5	15.5	1.7	7.2	6.5	6.5
3	(N)ER030C	32.9	27.7	30.8	16.8	16.8	13.7	16.8	14.0	14.0	1.7	8.5	3.2	3.2
5	(N)ER050L	33.5	29.0	32.5	17.5	17.5	13.3	16.8	15.7	15.7	1.9	9.1	3.4	3.3

*The (N)ER030L listed is the previous hoist model. Refer to Harrington catalog C-EPH for features and benefits.

HARRINGTON NER/ER THREE PHASE ELECTRIC CHAIN HOISTS



NER/ER010LD
(Shown with
optional canvas
chain container)

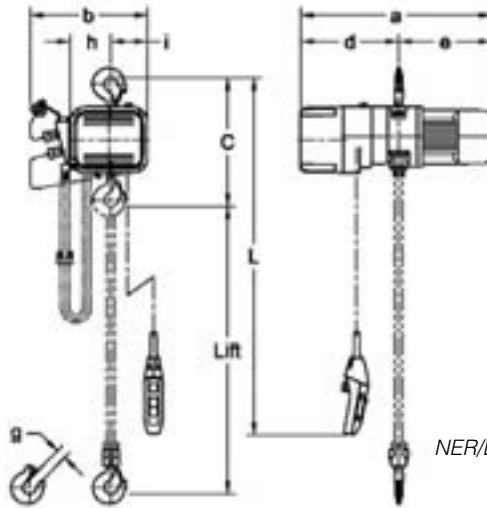

NER/ER010LD

DUAL SPEED — SPECIFICATIONS

Cap. (Tons)	Product Code	Standard Lift (ft)	Push Button Cord L (ft)	Lifting Speed (ft/min)	Lifting Motor 3 Phase 60 Hz [†]			Load Chain Diameter (mm) x Chain Fall Lines	Net Weight (lbs)		Weight for Additional One Foot of Lift (lbs)
					Output (Hp)	Rated Current (amps)			NER	ER	
						@208 – 230V	@460V				
1/8	(N)ER001HD	10	8.2	55/9	0.75	3.6	1.8	4.3 x 1	60	64	0.28
1/4	(N)ER003SD			36/6	0.75	3.6	1.8	4.3 x 1	60	64	0.28
1/4	(N)ER003HD			53/9	1.2	5.1	2.7	6.0 x 1	77	82	0.54
1/2	(N)ER005LD			15/2.5	0.75	3.6	1.8	6.0 x 1	68	79	0.54
1/2	(N)ER005SD			29/5	1.2	5.1	2.7	6.0 x 1	77	82	0.54
1	(N)ER010LD			14/2.5	1.2	5.1	2.7	7.7 x 1	99	108	0.89
1	(N)ER010SD			28/4.5	2.4	9.1	4.5	7.7 x 1	115	117	0.89
1 1/2	(N)ER015SD			18/3	2.4	9.1	4.5	10.2 x 1	159	172	1.6
2	(N)ER020CD			7/1	1.2	5.1	2.7	7.7 x 2	123	132	1.8
2	(N)ER020LD			14/2.5	2.4	9.1	4.5	10.2 x 1	161	174	1.6
2	(N)ER020SD			28/4.5	4.7	17.3	8.3	10.2 x 1	196	203	1.6
2 1/2	(N)ER025SD			22/3.5	4.7	17.3	8.3	11.2 x 1	218	231	1.9
3	(N)ER030LD*			17/6	4.7/1.6	19.6/9.4	9.8/4.7	12.5 x 1	300	300	2.3
3	(N)ER030CD			17/3	4.7	17.3	8.3	10.2 x 2	229	238	3.2
5	(N)ER050LD			11/2	4.7	17.3	8.3	11.2 x 2	280	293	3.8

*The (N)ER030LD listed is the previous hoist model. Refer to Harrington catalog C-EPH for features and benefits.

† Although both 208/230 & 460 Volts are shown together, the motors are NOT reconnectable.

NER/ER Electric Chain Hoists with Hook and Lug Suspensions



NER/ER020LD
(Shown with optional canvas chain container)

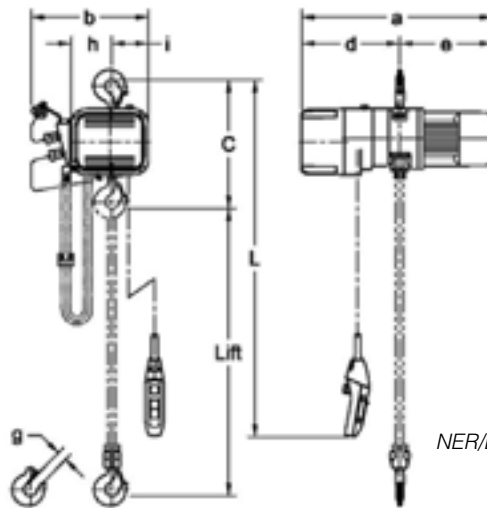

NER/ER020LD

DUAL SPEED — DIMENSIONS

Cap. (Tons)	Product Code	Headroom C (in)	a (in)		b (in)	d (in)		e (in)		g (in)	h (in)	i (in)
			NER	ER		NER	ER	NER	ER			
1/8	(N)ER001HD	13.8	21.1	22.2	13.6	10.9	12.0	10.2	10.2	1.1	3.9	4.6
1/4	(N)ER003SD	13.8	21.1	22.2	13.6	10.9	12.0	10.2	10.2	1.1	3.9	4.6
1/4	(N)ER003HD	14.6	22.4	23.3	13.7	11.8	12.8	10.6	10.6	1.1	4.5	4.2
1/2	(N)ER005LD	14.6	22.5	23.6	13.7	11.8	12.8	10.7	10.8	1.1	4.5	4.2
1/2	(N)ER005SD	14.6	22.4	23.3	13.7	11.8	12.8	10.6	10.6	1.1	4.5	4.2
1	(N)ER010LD	16.9	24.2	24.9	14.8	12.4	13.1	11.7	11.8	1.2	5.1	4.7
1	(N)ER010SD	16.9	24.5	25.2	14.8	12.4	13.1	12.1	12.1	1.2	5.1	4.7
1 1/2	(N)ER015SD	20.1	28.0	29.1	16.8	14.7	15.6	13.3	13.4	1.3	6.3	5.4
2	(N)ER020CD	27.8	24.2	24.9	14.8	12.4	13.1	11.7	11.8	1.5	7.0	2.7
2	(N)ER020LD	22.6	28.0	29.1	16.8	14.6	15.6	13.3	13.4	1.5	6.3	5.4
2	(N)ER020SD	23.2	30.2	30.8	16.8	16.2	16.8	14.0	14.0	1.5	6.3	5.4
2 1/2	(N)ER025SD	24.6	31.5	32.5	17.5	15.8	16.8	15.7	15.7	1.5	6.9	5.6
3	(N)ER030LD*	22.6	26.9	26.9	16.5	12.4	12.4	14.4	14.4	1.5	6.1	5.2
3	(N)ER030CD	32.9	30.2	30.8	16.8	16.2	16.8	14.0	14.0	1.7	8.5	3.2
5	(N)ER050LD	33.5	31.5	32.5	17.5	15.8	16.8	15.7	15.7	1.9	9.1	3.4

*The (N)ER030LD listed is the previous hoist model. Refer to Harrington catalog C-EPH for features and benefits.